

**The Development of Dunfermline Abbey as a royal cult centre  
*c.1070-c.1420***

**SangDong Lee**

**A thesis submitted in fulfilment of the requirements for the degree of  
Doctor of Philosophy**

**University of Stirling**

**February 2014**

## Contents

	<u>Page No.</u>
Declaration	ii
Abstract	iii
Acknowledge	iv
Abbreviations	vi
<b><u>Introduction</u></b>	1
<b><u>Chapter 1: The Miracles of St Margaret and Pilgrimage to Dunfermline</u></b>	
(1) Introduction	15
(2) The collection of miracles and its collectors	18
(3) The recipients of St Margaret's miracles	31
(4) The genres of St Margaret's miracles	40
(5) The characteristics of St Margaret's miracles	54
(6) Pilgrimage to Dunfermline	64
(7) Conclusion	80
<b><u>Chapter 2: Lay patronage of Dunfermline Abbey</u></b>	
1) Introduction	85
(2) David I (1124-53)	93
(3) Malcolm IV (1153-65)	105
(4) William I (1165-1214)	111
(5) Alexander II (1214-1249)	126
(6) Alexander III (1249-86)	136
(7) The Guardians, John Balliol and pre-Robert I (1286-1306)	152
(8) Robert I (1306-1329)	158
(9) David II (1329-71)	166
(10) The Early Stewart Kings (1371-1406)	176
(11) Conclusion	188
<b><u>Chapter 3: The Liturgical and Devotional Space of Dunfermline Abbey</u></b>	
(1) Introduction	201
(2) The earlier church, c.1070-1124	208
(3) The Twelfth century church	229
(4) The Thirteenth century church	251
(5) The Fourteenth century church	278
(6) Conclusion	293
<b><u>Conclusion</u></b>	297
Bibliography	305

**Declaration**

I hereby declare that this thesis has been composed by myself, and that the work which it embodies has been done by myself and has not been included in any other thesis.

**Singed** \_\_\_\_\_ **Date** \_\_\_\_\_

## **Abstract**

This thesis examines the development the cult of St Margaret at Dunfermline as a royal cult from 1070, the moment when St Margaret married King Malcolm III at Dunfermline, to 1420, the year of the burial of Robert duke of Albany who was the last royal member to be buried at Dunfermline. Scholars have focused on the life of St Margaret and her reputation or achievement from the biographical, institutional and hagiographical point of view. Although recent historians have considered St Margaret as a royal saint and Dunfermline as a royal mausoleum, they have approached this subject with relatively simple patterns, compared to the studies of the cults of European royal saints and their centres, in particular, those of English and French Kingdoms which influenced Scottish royalty.

Just as other European royal cults such as the cults at Westminster and St-Denis have been researched from the point of view of several aspects, so the royal cult at Dunfermline can be approached in many ways. Therefore, this thesis will examine the development of Dunfermline Abbey as a royal cult centre through studying the abbey and the cult of St Margaret from the point of view of miracles and pilgrimage, lay patronage, and liturgical and devotional space. The examination of St Margaret's miracles stories and pilgrimage to Dunfermline contribute to understanding these stories in the context of the development of the cult. The study of lay patronage explains the significance of royal favour and non-royal patrons in relation to the development of the cult, and how and why the royal cult developed and declined, and how the monks of Dunfermline promoted or sustained the cult of the saint. Lastly, the research of the liturgical and devotional space provides an explanation of the change of liturgical space from the point of view of the development of the cult.

## Acknowledgements

I would like to thank my supervisor Dr Michael Penman for his generosity and kindness. He always encourages me to keep going. Without his support and understanding of my circumstances, my life might be quite different from now. As a scholar and a supervisor, Michael is a good model for me to follow. Professor Richard Oram, my secondary supervisor, also provides me with valuable support. In particular, his comments on the part of the liturgical space have been very helpful. Dr John Taylor who taught me Latin and Dr Alastair Ross, whose palaeography class was a huge challenge for me, deserve to receive my appreciation. I need to mention my colleagues, the old B19-er, David, Stuart, Francesca, Nara, Mark. Although B19 does not belong to us any more, it will be in my memory. I also thank Lucy and Sean, who read part of my draft and gave me helpful comments.

My thanks also have to go to my dear friends, Dan, Niki, the late Alvin and Barbara. Their spiritual and psychological supports make me strong. Mrs. Gibson, Daseok, InSuk, SeoungBum and Euny help me not to be homesick. Professor DongSoon Kim, who initially led me to the western medieval world, deserves my thanks. PanJa Jin, my mother-in-law, Minhee Heo and MinYoung Heo, my sister-in-laws, help me and my family pass through the hard times. Even though I do not mention their name, I always appreciate all my friends who care for me and my family.

My precious, Dayeon, SeoungMin and Daown are my strong supporters. Their encouragement is the most powerful. I appreciate they are well growing up. Without the support and care of my parents, ByungWoo Lee and Suky Seo, I could not be here. I always appreciate their support and patience. My first and last girl, MinJeong Heo, as another kind of supervisor, guides me right direction. A number of difficulties MinJeong and I have

overcome over here have strengthened our relationship. I should also mention that MinJeong Heo is still so beautiful.

In the end, without any doubt, I can say that a quarter of this thesis is written by my supervisor Michael Penman's generosity and enthusiasm, a quarter by my parent's, ByungWoo Lee's and Suky Seo's endless care, the rest by MinJeong Heo's sacrifice – my effort to complete this thesis is a trifle.

## Abbreviation

<i>CDS</i>	<i>Calendar of Documents relating to Scotland</i> , ed. J. Bain, 5 vols. (Edinburgh, 1881-88)
<i>Chron. Bower</i>	Bower, Walter, <i>Scotichronicon</i> , eds. D.E.R. Watt, <i>et al</i> , 9 vols. (Aberdeen, 1987-1999)
<i>Chron. Fordun</i>	<i>Johannis de Fordun, Chronica Gentis Scotorum</i> , ed. W.F. Skene, (Edinburgh, 1871)
<i>Chron. Wyntoun (Laing)</i>	Andrew Wyntoun, <i>The Original Chronicle of Scotland</i> , ed. David Laing, 3 vols. (Edinburgh, 1879)
<i>ER</i>	<i>The Exchequer Rolls of Scotland</i> , eds. J. Stuart <i>et al</i> , 23 vols. (Edinburgh, 1878-1908)
<i>ESSH</i>	<i>Early Sources of Scottish History: 500-1286</i> , ed. A.O. Anderson, 2 vols. (London, 1922)
<i>Finucane, Miracles and Pilgrims</i>	Ronald C. Finucane, <i>Miracles and Pilgrims: popular beliefs in Medieval England</i> (London, 1995)
<i>Handlist, i</i>	J. Scouler ed., <i>Handlist of the Acts of Alexander II, 1214-49</i> (Edinburgh, 1959)
<i>Handlist, ii</i>	Grant G. Simpson ed., <i>Handlist of the acts of Alexander III, the Guardians, John, 1249 - 1296</i> (Edinburgh, 1960)
<i>Lawrie, Charters</i>	<i>Early Scottish Charters prior to 1153</i> , ed. A. C. Lawrie, (Glasgow, 1905)

<i>Miracula</i>	<i>The miracles of St Aebba of Coldingham and St Margaret of Scotland</i> , ed. Robert Bartlett, (Oxford, 2003)
ODNB	<i>Oxford Dictionary of National Biography</i> (Oxford University Press, 2004)
PoMS	The People of Medieval Scotland, 1093 - 1314
PSAS	<i>Proceedings of the Society of Antiquaries of Scotland</i>
<i>Registrum de Dunfermelyn</i>	<i>Registrum de Dunfermelyn liber cartarum Abbatie Benedictine S.S. Trinitatis et B. Margarete Regine de Dunfermelyn</i> , Bannatyne Club, (Edinburgh, 1842)
RMS	<i>Registrum magni sigilli Regum Scotorum : The register of the Great seal of Scotland, A.D. 1306-1424</i> , ed. J. M. Thomson, 2 vols. (Edinburgh, 1882-1912)
RPS	<i>Records of the Parliaments of Scotland to 1707</i>
RRS	<i>Regesta Regum Scottorum</i>
TA	<i>Accounts of the Lord High Treasurer of Scotland</i> , eds. T. Dickson and J. Balfour Paul, 4 vols. (Edinburgh, 1877-1902)
<i>The Charters of David I</i>	<i>The Charters of David I</i> , ed. G. W. S. Barrow, (Woodbridge, 1999)
<i>The Monastic Constitutions of Lanfranc</i>	<i>The Monastic Constitutions of Lanfranc</i> , eds. David Knowles and Christopher N. L. Brooke, (Oxford, 2002)
Turgot, <i>Life of St. Margaret</i>	Turgot, <i>Life of St. Margaret, Queen of Scotland</i> , William Forbes-Leith. ed. (Edinburgh: W. Paterson, 1884)



## Introduction

Margaret fled to Scotland in 1068, along with her mother and a sister and a brother, Edgar Atheling (c.1051- 1126). He could have been inaugurated to be an heir of Edward the Confessor after the sudden death of his father, Edward the Exile (1016-1057). However, he could not have sat on the throne because of the Norman Conquest of England in 1066.<sup>1</sup> Margaret emerged as a crucial figure in Scottish history by marrying King Malcolm III of Scotland (c.1031-1093) in 1070. When she became a queen of Scotland, the Celtic church in Scotland involved none of the reformed monastic style of western Christendom,<sup>2</sup> although there were other monastic communities in Scotland such as those at Coldingham, Old Melrose, Dunkeld, St Andrews, Brechin and Iona etc.<sup>3</sup> The Celtic features of the Scottish church influenced religious practices such as worship, observation, organization and even architecture. For example, marriage was not a strict system but could be a kind of polygamy, a custom dating back to pre-Christian Irish society. The laity confessed infrequently to clerics, and in consequence, they received communion only occasionally. The Scots were not interested in receiving communion even at Easter. The reformists criticized the Eucharist, which was performed in the Scottish church, as a 'barbarous rite'.<sup>4</sup> Furthermore, children might be allowed communion, which was not an uncommon practice in the Celtic church. Adoption of the date of fasts also followed the Irish system: 'the Scots began their Lent four days after Ash Wednesday and reckoned the six Sundays before Easter as fast days, another

---

<sup>1</sup> Alan Macquarrie, 'St Margaret of Scotland' in *The Saints of Scotland: Essays in Scottish Church History AD 450~1093* (Edinburgh, 1997), 212.

<sup>2</sup> G.W.S. Barrow, *The Kingdom of the Scots* (2<sup>nd</sup> edition, Edinburgh, 2003), 151. Since the Celts lived in a scattered rural world and they had a long tradition of migration, each church seems to have been considered an independent one: they 'saw bishops and priests much more as wandering evangelists than as settled ministers exercising pastoral and administrative functions within a fixed area (Ian Bradley, *The Celtic Way* (London, 1993), 23-4).' For the Celtic Christianity see Donald E. Meek, *The Quest for celtic christianity* (Edinburgh, 2000).

<sup>3</sup> Ian B. Cowan and D. E. Easson, *Medieval Religious Houses: Scotland* (London, 1976), 2-3.

<sup>4</sup> G.W.S. Barrow, *Kingship and Unity: Scotland 1000-1306* (Edinburgh, 2003), 71.

archaic observance in line with the unreformed Irish church.<sup>5</sup> The Scottish church venerated several saints of Irish origin such as Fáelán, Colmán, Findbarr, Finán, Donnán of Eigg, Moluoc of Lismuoc, Maelrubha of Applecross. There were also Irish origins to dignitaries such as the ab (abbe), ‘the head or abbot of a monastic church of Irish type, holding an office that had usually become secularized before the twelfth century.’<sup>6</sup>

These characteristics of the Scottish church might have left Margaret shocked and denied her association with it because she had grown up at courts familiar with Roman church practices. Therefore, she tried to provide the Scottish church with the reformed monastic style. First of all, she attempted to introduce Benedictine monasticism into Scotland from England, by requesting that Lanfranc, archbishop of Canterbury, send Benedictine monks to the church at Dunfermline: non-Celtic monasticism was brought into Scotland.<sup>7</sup> However, it does not mean that she detested the customs of the Scottish church. She supported local churches such as those at Loch Leven, Laurencekirk, and especially Iona, and thus St Columba, St Serf etc,<sup>8</sup> and that her generosity to religious houses in Celtic regions of southwest Scotland was recorded in the *Vita* of St Laurence of Canterbury, which was written by a Benedictine hagiographical writer, Goscelin of St Bertin, living at Canterbury in the late eleventh century.<sup>9</sup>

The reality of Margaret’s contribution to the reform of the Scottish church has been much debated by historians. A.R. MacEwan rejected Margaret’s role in the establishment of a diocesan system in Scotland, or the reform of the Scottish native monastic organization, describing Margaret as ‘a reformer of religion rather than a reformer of the church, [who]

---

<sup>5</sup> *Ibid*, 71-2.

<sup>6</sup> *Ibid*, 72-3; Alan J. Wilson, *St Margaret, Queen of Scotland* (Edinburgh, 2001), 79-85.

<sup>7</sup> *The Letters of Lanfranc Archbishop of Canterbury*, eds. H. Clover and M. Gibson (Oxford, 1979), 160-3.

<sup>8</sup> A.D.M. Barrell, *Medieval Scotland* (Cambridge, 2000), 43; A. Macquarrie, ‘An eleventh-century account of the foundation legend of Laurencekirk, and of Queen Margaret’s pilgrimage there’, *Innes Review*, xlvii (1996), 95-109.

<sup>9</sup> Macquarrie, ‘St Margaret of Scotland’, 216.

influenced the tone of Christianity rather than its ordinances.’<sup>10</sup> Burleigh remarked that ‘even the critical eye of so good a Catholic as Queen Margaret could detect only minor failings’, and that she ‘undertook no drastic reform of the Scottish Church.’<sup>11</sup> In his opinion, the most important achievement of St Margaret was her children’s upbringing.<sup>12</sup> For Donaldson, Margaret’s plan ‘had at the best been a limited one’ and ‘she did nothing, apart from bring a few Benedictine monks to Dunfermline, to foster and endow new institutions.’ He also stated that the most significant feat of Margaret was to raise six sons and two daughters.<sup>13</sup>

However, G.W.S. Barrow emphasised Margaret’s role in reform of the Scottish church:

no history of Scotland in the eleventh and twelfth centuries would be adequate if it failed to recognize that in associating Lanfranc with her reforming activity in Scotland, in introducing under Cantuarian auspices, a wholly new kind of religious life north of the Forth, above all in inspiring in her sons, her husband’s successors, a zeal and devotion towards the forms of religious life and ecclesiastical observance familiar in Norman England and on the continent, Queen Margaret was knowingly and deliberately instigating changes which for both Church and Nation were of fundamental, far-reaching significance.<sup>14</sup>

Although Cowan and Easson accepted the significance of the introduction of Benedictine monasticism into Scotland, presumably at Dunfermline, they suggested that Margaret’s reputation as ‘the instigator of a new order within the ecclesiastical sphere in Scotland’ was exaggerated, remarking that her ‘innovations ...were modest contributions towards the alignment of Scottish ecclesiastical institutions with those of Western Christendom.’<sup>15</sup> By underlining David Knowles’ remark that the ‘Scottish court had been something of a nursery of saints’ in the time of Queen Margaret and her children, Derek Baker considered her

---

<sup>10</sup> A. R. MacEwan, *A History of the Church in Scotland* (London, 1913), 160.

<sup>11</sup> J.H.S. Burleigh, *A Church History of Scotland* (London, 1960), 37, 44.

<sup>12</sup> *Ibid*, 43.

<sup>13</sup> Gordon Donaldson, *Scotland: Church and Nation through Sixteenth Centuries* (London, 1960), 18-9.

<sup>14</sup> G.W.S. Barrow, ‘From Queen Margaret to David I: Benedictines and Tironensians’, *Innes Review*, xi (1960), 27-8.

<sup>15</sup> Cowan and Easson, *Medieval Religious Houses: Scotland*, 4-5.

children's upbringing to be Margaret's crucial legacy in the reform of the Scottish church.<sup>16</sup> More recently, Alan Macquarrie has pointed out the limitation of Margaret's power and influence, indicating that 'for all the strength of her personality, and for all King Malcolm's affectionate support, (Margaret) was a political exile, a foreigner, a member of a dispossessed dynasty which was entirely dependent on the generosity of the Scottish court, and a woman.'<sup>17</sup>

Scholars are also aware that Margaret's reputation was built up by her own dynasty in the twelfth and thirteenth centuries. For A. A. M. Duncan, there is insufficient evidence to believe that the innovations concerning the development of the Scottish church happened in the late eleventh and the early twelfth centuries. Instead he suggested that the characteristics of the new monasticism have been found in documents from the later twelfth century. He also remarked that Margaret and her three sons, Edgar, Alexander and David, sought to modify the native Scottish church gradually rather than revolutionize it.<sup>18</sup> In other words, it required the time including the reigns of Margaret's sons for the results of her efforts to change the Scottish church to be seen. Valerie Wall has emphasised Margaret's role as part of the founding royal couple of the dynasty with Malcolm III, indicating that 'after the establishment of this family as kings and the development of Dunfermline as the national royal mausoleum, the Scottish regal lists added a standard formula', reiterating that Margaret's 'real legacy was in the work of her surviving children, all of whom in some way demonstrated a deep and enduring personal commitment to religious reform and strong personal piety, and who re-established and expanded greatly upon their parent's earlier

---

<sup>16</sup> David Knowles, *The Monastic Order in England: A History of its Development from the Times of St Dunstan to the Fourth Lateran Council 940-1216*, 2<sup>nd</sup> ed., (Cambridge, 1963), 242; Derek Baker, 'A Nursery of Saints': St Margaret of Scotland Reconsidered' in *Medieval Women* ed., Derek Baker (Oxford, 1978), 119-41.

<sup>17</sup> Macquarrie, 'St Margaret of Scotland', 223.

<sup>18</sup> A.A.M. Duncan, *Scotland: The Making of the Kingdom* (Edinburgh, 1975), 117-32, 150-1.

foundation.’<sup>19</sup> Richard Oram has been sceptical of the information indicating Margaret’s career as a religious reformer. He has pointed out that her career as a religious reformer was invented by her former chaplain and confessor, Turgot, who wrote the *Vita S. Margarete* at the request of her daughter, Queen Matilda (d. 1118), the wife of English King Henry I.<sup>20</sup>

Although scholars have evaluated Margaret’s achievement in these slightly different ways, they all have focused on the life of St Margaret and her reputation or achievement from the biographical, institutional and hagiographical point of view. They also accept that her production of eight children, six sons and two daughters, and their careful upbringing was one of her significant achievements. Of her six sons, three sat on the throne: Edgar (1097–1107), Alexander I (1107-24) and David I (1124-53). Apart from their foundation of many other religious houses, it is shown that the three kings had a strong interest in devotion to the church at Dunfermline, which their mother, Queen Margaret, founded with the aid of Archbishop Lanfranc. King Edgar requested Archbishop Anselm to dispatch monks from Canterbury to Dunfermline Priory,<sup>21</sup> just as had Queen Margaret. Alexander translated the remains of his father, which were buried at Tynemouth Priory in Northumberland nearby his death place at Alnwick, to Dunfermline.<sup>22</sup> Above all, David I’s support to Dunfermline was impressive. Probably between 1126 and 1127, he requested William of Corbeil, archbishop of Canterbury, and the convent of Canterbury Cathedral Priory, to send a monk who would be the first abbot of Dunfermline. Then Dunfermline Priory was raised to abbatial status in 1128

---

<sup>19</sup> Valerie Wall, ‘Queen Margaret of Scotland (1070-93): Burying the Past, Enshrining the Future’ in Anne Duggan ed., *Queens and Queenship in Medieval Europe* (Woodbridge, 1997), 27-38, quote at 37.

<sup>20</sup> Richard Oram, *David I: The King Who Made Scotland* (Stroud, 2004), 27-9, quote at 27. In fact, prior to Oram, Lois L. Huneycutt had pointed out that Margaret’s reputation was built up by English Queen Matilda and the *Vita S. Margarete*, which was used in the court of Queen Matilda and became an crucial text demonstrating an ideal of medieval queenship (Lois L. Huneycutt, ‘The Idea of the Perfect Princess: The Life of St Margaret in the Reign of Matilda II (1100-18)’ in M. Chibnall ed., *Anglo-Norman Studies*, xii (Woodbridge, 1990), 81-97, quote at 97).

<sup>21</sup> Archibald Campbell Lawrie ed., *Early Scottish charters prior to A.D. 1153: with notes and an index* (Glasgow, 1905) [hereafter, Lawrie, *Charters*], no. 25.

<sup>22</sup> William of Malmesbury, *Gesta Regum Anglorum: The History of the English Kings*, i, eds. R.A.B. Mynors, R.M. Thomson and M. Winterbottom (Oxford, 1998), 464- 5; *John of Fordun’s Chronicle of the Scottish nation*, ed. W. F. Skene, (Edinburgh, 1872), 208; *Early Sources of Scottish History: 500-1286*, ed. A.O. Anderson, 2 vols. (London, 1922) [hereafter, *ESSH*], ii. 53.

when Geoffrey, prior of Christ Church of Canterbury, was appointed as the first abbot by David I.<sup>23</sup> Moreover, as discussed in Chapter Two, with his building scheme to extend the church, David intended to establish Dunfermline Abbey as a royal mausoleum and promote the cult of St Margaret, that is, as a centre of dynastic cult.

Recently scholars have expanded their interest in the cult of the saints in Medieval Scotland and suggested new approaches to this subject, which may in part have been motivated by the Survey of Dedications to Saint in Medieval Scotland Project carried out at the University of Edinburgh from 2004-07.<sup>24</sup> In his recent article, David Ditchburn has criticized Monsignor David McRoberts who argued that before the fifteenth century the Scottish church ignored the earlier Scottish saints and that nationalism from the fifteenth century contributed to the development of a cult of national saints.<sup>25</sup> Ditchburn indicates that to understand the late medieval religious significance of the Scottish saints it is necessary to analyse the pattern of sanctity in earlier medieval Scotland with a broader and more flexible approach to the subject than McRoberts' 'rigid dichotomy between international and national saints.'<sup>26</sup> Thomas Owen Clancy has pointed out that crucial secondary sources such as Mackinlay's *Ancient Church Dedications* and Watson's *Celtic Place-Names of Scotland*<sup>27</sup> were based on unclear evidence, arguing that there are limitations to the established paradigms for tracing the historical existence of a saint in local dedication, warning that the cult of one saint could be transformed into the cults of several distinct saints. He suggests that since it is not enough to understand the cults of the saints with a simple pattern, a number of

---

<sup>23</sup> G.W.S. Barrow ed., *The Charters of David I: The Written Acts of David I King of Scots, 1124 - 53, and of his son Henry, Earl of Northumberland, 1139 - 52* (Woodbridge, 1999) [hereafter, *The Charters of David I*], 63-4, no. 22.

<sup>24</sup> For the database of Dedications to Saints in Medieval Scotland, accessed on <http://webdb.ucs.ed.ac.uk/saints/>

<sup>25</sup> David McRoberts, 'The Scottish Church and nationalism in the fifteenth century', *Innes Review*, 19 (1968), 3-14.

<sup>26</sup> David Ditchburn, 'The 'McRoberts Thesis' and Patterns of Sanctity in Late Medieval Scotland' in Steve Boardman and Eila Williamson eds., *The Cult of Saints and the Virgin Mary in Medieval Scotland* (Woodbridge, 2010), 177-94.

<sup>27</sup> James Murray Mackinlay, *Ancient Church Dedication in Scotland: Non-Scriptural Dedication* (Edinburgh, 1914); W. J. Watson, *The History of the Celtic Place-Names of Scotland* (Edinburgh, 1926).

new patterns are required for providing alternative explanations concerning the pattern in place-name and church dedication to a specific saint.<sup>28</sup>

Concerning the cult of St Margaret at Dunfermline, an edited book, *Royal Dunfermline* (2005), provides us with a wide range of aspects of the cult of St Margaret at Dunfermline. In chapter seven of this book, Steve Boardman has considered St Margaret an object of the cult, and Dunfermline a royal mausoleum.<sup>29</sup> In the same volume, Peter Yeoman has approached Dunfermline Abbey from the point of view of the cult shrine, which further develops research from his previous study of medieval pilgrimage in Scotland.<sup>30</sup> Richard Fawcett has examined the architectural development of Dunfermline Abbey,<sup>31</sup> in comparison to previous research carried out by antiquarian F. C. Eeles, and scholars such as Stewart Cruden and Eric Fernie.<sup>32</sup> More recently Michael Penman's researches on Scottish royal piety have included discussion of the significance of the cult of St Margaret and Dunfermline Abbey in the context of royal piety and political circumstances c.1214-c.1286 and c.1306-c.1329.<sup>33</sup>

---

<sup>28</sup> Thomas Owen Clancy, 'The Big Man, the Footsteps, and the Fissile Saint: Paradigms and Problems in Studies of Insular Saints' Cults' in Boardman and Williamson eds., *The Cult of Saints and the Virgin Mary in Medieval Scotland*, 1-20. In addition, recently Thomas JM. Turpie has completed his research on the Scottish saints cults and pilgrimage in the late Middle Ages (Thomas JM. Turpie, 'Scottish saints cults and pilgrimage from the Black Death to the Reformation, c.1349-1560' (University of Edinburgh, unpublished PhD thesis, 2011), and his case studies of SS Ninian and Cuthbert in particular challenging 'national' saint boundaries.

<sup>29</sup> Steve Boardman, 'Dunfermline as a Royal Mausoleum' in Richard Fawcett ed., *Royal Dunfermline* (Edinburgh, 2005), 139-54.

<sup>30</sup> Peter Yeoman, 'Saint Margaret's Shrine at Dunfermline Abbey' in Fawcett ed., *Royal Dunfermline*, 79-88; Peter Yeoman, *Pilgrimage in Medieval Scotland* (London, 1999), 71-4.

<sup>31</sup> Richard Fawcett, 'Dunfermline Abbey Church' in Fawcett ed., *Royal Dunfermline*, 27-64.

<sup>32</sup> F. C. Eeles, 'The Development and internal arrangements of the abbey Church of Dunfermline' in Erskine Beveridge ed., *The Burgh Records of Dunfermline* (Edinburgh, 1917), xxxi-xlvii; Stewart Cruden, *Scottish Medieval Churches* (Edinburgh, 1986), 20-38; Eric Fernie, 'The Romanesque churches of Dunfermline Abbey', in John Higgitt ed., *Medieval art and architecture in the diocese of St Andrews* (Leeds, 1994), 25-37.

<sup>33</sup> Michael Penman, 'Royal piety in Thirteenth-century Scotland: The Religion and Religiosity of Alexander II (1214-49) and Alexander III (1249-86)' in Janet Burton, Philipp Schofield and Bjorn Weiler eds., *Thirteenth Century England*, XII (Woodbridge, 2009), 13-30; Michael Penman, "'Sacred food for the soul?": the devotions to saints or Robert I, c.1306-c.1329', *Speculum* 88 (4) (2013), 1035-1062. Although it is not research into the cult of St Margaret at Dunfermline, Richard Oram's work on the cult of St Ninian at Whithorn suggests an approach to the cult of the saint in the context of the development of the cult of the saint (Richard Oram, 'The Medieval Bishops of Whithorn, their Cathedral and their Tombs' in Christopher Lowe ed., *Clothing for the Soul Divine': Burials at the Tombs of St Ninian* (Edinburgh, 2009), 131-65).

In spite of these studies, the cult of St Margaret as a royal saint and Dunfermline Abbey as a centre of dynastic cult have been less researched, compared to the studies of the cults of European royal saints and their centres, in particular, those of the English and French kingdoms which influenced Scottish royalty. Some scholars such as Barbara Harvey and Emma Mason have studied the relationship between Westminster Abbey, which was dedicated to St Edward the Confessor and a centre of English royal cult, and English royal members prior to Henry III.<sup>34</sup> In fact, it was the mid-thirteenth century when Westminster Abbey was reconstructed to be a royal mausoleum and a centre of English dynastic cult by the building scheme of King Henry III. Suzanne Lewis and Christopher Wilson have researched the architectural core of Westminster Abbey which has been attributed to Henry III's involvement.<sup>35</sup> In his book, *Westminster Abbey and the Plantagenets: Kingship and the Representation of Power, 1200-1400*, Paul Binski has studied Westminster Abbey from the point of view of a wide range of aspects such as the invention of the cult of St Edward, the function of the abbey as a royal mausoleum and as a centre of dynastic cult, through the examination of the church building and the associated work of art in the context of political and ideological purposes as well as devotional and liturgical functions.<sup>36</sup> D. A. Carpenter has examined how the cult of St Edward was treated by King Henry III and the magnates during the period of political turmoil, 1258-1269.<sup>37</sup> More recently Carpenter suggests when and why Henry's devotion to the Confessor was established, which was a question other scholars had

---

<sup>34</sup> Barbara Harvey, *Westminster Abbey and its Estates in the Middle Ages* (Oxford, 1977), Ch. 1. 'The foundation of Westminster Abbey', 20-5; Emma Mason, 'Westminster Abbey and the Monarchy between the Reigns of William and John 1066-1216' in *Westminster Abbey and its people c. 1050-c. 1216* (Woodbridge, 1996), 269-87.

<sup>35</sup> Christopher Wilson, 'Calling the Tune? The Involvement of King Henry III in the Design of the abbey Church at Westminster', *Journal of the British Archaeological Association*, 161 (2008), 59-93; Suzanne Lewis, 'Henry III and the Gothic Rebuilding of Westminster Abbey: The Problematic of Context' in E. A. R. Brown, B. E. Daley and J. J. O'donnell *et.al.* eds., *Traditio: Studies in Ancient and Medieval History, Thought, and Religion* (New York, 1995), 129-72.

<sup>36</sup> Paul Binski, *Westminster Abbey and the Plantagenets: Kingship and the Representation of Power, 1200-1400* (New Haven; London, 1995).

<sup>37</sup> D. A. Carpenter, 'Westminster Abbey in Politics, 1258-1269' in Michael Prestwich, Richard Britnell and Robin Frame eds., *Thirteenth Century England VIII* (Woodbridge, 2001), 49-70.



not answered. He argues that Henry III's devotion to the Confessor was forged in the 1230s when he attempted to strengthen his kingship.<sup>38</sup> D. M. Palliser's research has examined the cult of St Edward and Westminster Abbey as a royal mausoleum, through investigating the English kings' attitude to Westminster c.1272-1422.<sup>39</sup>

Unlike the approaches of Carpenter and Palliser to the cult of St Edward at Westminster, Elizabeth M. Hallam has examined the cult from the point of view of comparison of the English dynastic cult with the French royal cult. Remarking that the ceremonial of royal burial had invented and promoted the dynastic cult, Hallam has suggested that from the 1240s St-Denis became again a centre of French royal cult, which motivated English kings, Henry III and Edward I, to make Westminster a centre of English dynastic cult in order to emulate that of French monarch.<sup>40</sup> Before Hallam's work, Georgia Summers Wright investigated the French royal tomb plan in the reign of Louis IX (1226-1270), and suggested that this was intended to promote royal power and kingship through emphasising the holy chrism of royal remains.<sup>41</sup> Elizabeth A. R. Brown discussed this point further, stating that the French royal tomb programme demonstrating respect for the remains of kings in part enhanced the myth of divine kingship and, in consequence, strengthened kings' authority.<sup>42</sup> Recently William Chester Jordan's comparative study between the centre of French dynastic cult and that of English royal cult, that is St Denis and Westminster, provided a broader

---

<sup>38</sup> D. A. Carpenter, 'King Henry III and Saint Edward the Confessor: The Origins of the Cult', *English Historical Review* CXXII, No. 498 (2007), 865-91.

<sup>39</sup> D. M. Palliser, 'Royal Mausolea in the Long Fourteenth Century (1272-1422)' in W. M. Ormrod ed., *Fourteenth Century England III* (Woodbridge, 2004), 1-16.

<sup>40</sup> Elizabeth M. Hallam, 'Royal burial and the cult of kingship in France and England, 1060-1330', *Journal of Medieval History*, vol. 8 (1982), 359-80.

<sup>41</sup> Georgia Summers Wright, 'A Royal Tomb Program in the Reign of St Louis', *Art Bulletin*, 56(2) (1974), 224-43.

<sup>42</sup> Elizabeth A. R. Brown, 'Burying and Unburying the Kings of France' in Richard C. Trexler ed., *Persons in Groups: Social Behavior as Identity Formation in Medieval and Renaissance Europe* (Binghamton, 1985), 241-66.

narrative of two rival kingdoms under the reigns of Henry III and Louis IX, and their successors.<sup>43</sup>

Just as other European royal cults such as the cults at Westminster and St-Denis have been researched from the point of view of several aspects, so the royal cult at Dunfermline can be approached in many ways. To accomplish it, this thesis will examine the development of Dunfermline Abbey as a royal cult centre through studying the abbey and the cult of St Margaret from the point of view of miracles and pilgrimage, lay patronage and liturgical and devotional space. Chapter One will examine St Margaret's miracles and medieval pilgrimage to Dunfermline. In general, there are several factors influencing the development of the cult of a saint. One of them is miracles which could provide pilgrims with motivation to visit the shrine. Concerning miracles, there are significant studies such as: Ronald C. Finucane's book, *Miracles and Pilgrims: Popular Belief in Medieval England* (1977, 1995) which analysed miracle collections statistically in a popular belief context;<sup>44</sup> Peter Brown's *The Cult of the Saints: Its rise and function in Latin Christianity* (1982, 1987), which interpreted posthumous miracles within an enlightenment critique of popular religion;<sup>45</sup> Benedicta Ward's *Miracles and the Medieval Mind: Theory, Record, and Event 1000-1215* (1987) which examined miracles in terms of theological and intellectual content;<sup>46</sup> and more recently Simon Yarrow's monograph of case studies which argued that miracles were a result of negotiation carried out by community members. According to Yarrow, since the result of negotiation had to be accepted by community members, miracles were collected or recorded by the elites who had been influential in the community.<sup>47</sup>

---

<sup>43</sup> William Chester Jordan, *A Tale of Two Monasteries: Westminster and Saint-Denis in the Thirteenth Century* (Princeton, 2009).

<sup>44</sup> Ronald C. Finucane, *Miracles and Pilgrims: popular beliefs in Medieval England* (London, 1995).

<sup>45</sup> Peter Brown, *The Cult of the Saints: Its rise and function in Latin Christianity* (Chicago, 1982, 1987).

<sup>46</sup> Benedicta Ward, *Miracles and the Medieval Mind: Theory, Record, and Event 1000-1215* (Pennsylvania, 1987).

<sup>47</sup> Simon Yarrow, *Saints and their Communities: Miracle Stories in Twelfth-Century England: Miracle Stories in Twelfth-Century England* (Oxford, 2006), 1- 23.

In spite of these researches on miracle stories, scholars have paid less attention to miracles relevant to royal saints and their cults. For the cult of St Margaret, thanks to Robert Bartlett, a fifteenth-century manuscript copy of a collection of miracles attributed to her, which had been removed from England by a Spanish ambassador in the seventeenth century and is now archived in Madrid [Madrid Biblioteca Real, MS II. 2097], was discovered.<sup>48</sup> Bartlett translated, edited and published the materials examining St Margaret's miracles, classifying them into categories and identifying their characteristics. However, Bartlett's study can be further developed by researching St Margaret's miracles in the context of their contribution to the development of the cult, providing information on pilgrims such as their social status or where they were from.

St Margaret's miracle collection also provides us with clues to study pilgrimage to Dunfermline. Previous researches concerning medieval pilgrimage such as Diana Webb's works,<sup>49</sup> and Jonathan Sumption's book<sup>50</sup> have provided readers with plentiful knowledge of medieval pilgrimage - their changing nature over time, strategies, tensions, rivalries and materiality. In the case of Scottish pilgrimage, Peter Yeoman, in his book *Pilgrimage in Medieval Scotland*, has tried to revive the scene of pilgrims visiting an evolving network of Scottish saints' familia, parochia and shrines.<sup>51</sup> With the aid of these valuable studies, it is possible to examine pilgrimage to Dunfermline Abbey.

Chapter Two will study lay patronage to Dunfermline. Patronage is one of the most important factors in the development of the cult of a saint, along with miracles and pilgrimage. Emilia Jamrozak demonstrates that even Cistercian monasteries which were removed from the secular world to keep their self-sufficient lifestyle, following the Rule of St

---

<sup>48</sup> Robert Bartlett ed., *The miracles of St Æ bba of Coldingham and St Margaret of Scotland* (Oxford, 2003) [hereafter *Miracula*], xxxi-xxxiv.

<sup>49</sup> Diana Webb, *Pilgrimage in Medieval England* (London, 2000); Diana Webb, *Medieval European Pilgrimage* (London, 2000).

<sup>50</sup> Jonathan Sumption, *Pilgrimage: An Image of Medieval Religion* (London, 1975).

<sup>51</sup> Peter Yeoman, *Pilgrimage in Medieval Scotland* (Edinburgh, 1998).

Benedict, also tried to attract lay patronage. For example, Cistercian Rievaulx Abbey which was located in a relatively remote part of Yorkshire attempted to remember and commemorate its benefactors by recording them in its Cartulary.<sup>52</sup> Furthermore, in the thirteenth century, the Cistercian Melrose Abbey in Scotland allowed its powerful lay benefactors to be buried in the chapter house, which was against Cistercian regulations prohibiting the burial of lay people within monastic churches and chapter houses.<sup>53</sup>

In the case of a centre of royal cult, it has been known that the monarch gave its strong patronage to a shrine venerating a royal saint or a dynastic cult such as Henry III's patronage to Westminster and Louis IX's to St-Denis. Royal patronage to a centre of dynastic cult was aimed not only to strengthen the monarchy's authority to overcome internal and external challenges but also to seek its spiritual salvation. Scottish royal patronage to Dunfermline Abbey can be studied in this context, along with its relationship with the development of the dynastic cult and other lay person's participation in patronage to the abbey. To study Scottish royal patronage to Dunfermline, the *Registrum de Dunfermelyn*, dating in part back to the reign of David I<sup>54</sup> will be examined. The series of volumes of acts of Scottish kings will also be investigated.<sup>55</sup> From these sources some evidence can be drawn about Scottish kings patronage to religious communities including Dunfermline, by which it is also possible to compare royal favour to Dunfermline with others. From the perspective of the monks of

---

<sup>52</sup> Emilia Jamroziak, 'How Rievaulx Abbey remembered its benefactors' in Emilia Jamroziak and Janet Burton eds. *Religious and laity in Northern Europe 1000 - 1400: Interaction, Negotiation and Power* (Turnhout, 2007), 63- 76.

<sup>53</sup> Emilia Jamroziak, 'Making friends beyond the grave: Melrose Abbey and its lay burials in the thirteenth century', *Cîteaux: Commentarii Cistercienses*, 56 (2005), 323-36.

<sup>54</sup> *Registrum de Dunfermelyn liber cartarum Abbatie Benedictine S.S. Trinitatis et B. Margarete Regine de Dunfermelyn* (Bannatyne Club; Edinburgh, 1842) [hereafter, *Registrum de Dunfermelyn*].

<sup>55</sup> *The Charters of David I*; G.W.S. Barrow ed., *The Acts of Malcolm IV (Regesta Regum Scottorum): Together with Scottish Royal Acts Prior to 1153 Not Included in Sir Archibald Lawrie's Early Scottish Charters* (Edinburgh, 1960) [hereafter, *RRS*, i]; G.W.S. Barrow ed., *The Acts of William I, 1165- 1214* (Edinburgh, 1971) [hereafter, *RRS*, ii]; J. Scoular ed., *Handlist of the Acts of Alexander II, 1214-49* (Edinburgh, 1959) [hereafter, *Handlist*, i]; Cynthia J. Neville and Grant G. Simpson eds., *The Acts of Alexander III, 1249 - 1286* (Edinburgh, 2012) [hereafter, *RRS*, iv]; Grant G. Simpson ed., *Handlist of the acts of Alexander III, the Guardians, John, 1249 - 1296* (Edinburgh, 1960) [hereafter, *Handlist*, ii]; A.A.M. Duncan ed., *The Acts of Robert I 1306 - 1329* (Edinburgh, 1988) [hereafter, *RRS*, v]; Bruce Webster ed., *The Acts of David II 1329 - 1371* (Edinburgh, 1982) [hereafter, *RRS*, vi]; *Registrum magni sigilli regum Scotorum: The register of the Great seal of Scotland, A.D. 1306 - 1424*, ed. J. M. Thomson (Edinburgh, 1912) [hereafter, *RMS*, i].

Dunfermline, it was essential to promote or sometimes sustain the reputation of the cult of St Margaret and Dunfermline Abbey. Chapter Two will also explore how the monks of Dunfermline tried to keep or draw kings' favour to the abbey and seek nobles' patronage to Dunfermline in the relationship with the promotion/maintenance of the cult of St Margaret.

It should also be mentioned about the *Registrum de Dunfermelyn* recording the patronage of the crown and the laity to the Dunfermline. The manuscripts had first been collected and researched by the first earl of Haddington in the seventeenth century. He collected and arranged the manuscript as follows: 'Charters of the kings from David to Alexander III.; the bishops of Saint Andrew and Dunkeld; the chapter of St Andrews; the earls of Fife and Atholl; countesses Ada and Ela; charters of Laymen; covenants and conventions regarding disputed territories; and Bulls of Popes.'<sup>56</sup> On the other hand, the current version edited by the Bannatyne Club in 1842 was compiled as follows: Charters of the kings from David I to Alexander III; the bishops of St. Andrews and Dunkeld; the chapter of St. Andrews; the earls of Fife and Atholl; the pope; charters of the kings from Robert I to James IV.<sup>57</sup> Concerning the *Registrum* as a source for research, as Alasdair Ross argues, it needs to be noted that the Scottish cartularies edited and published by antiquarian groups such as the Bannatyne, Maitland and Spalding Clubs between 1832 and 1893 were rearranged and reordered by their own intentions.<sup>58</sup>

Chapter Three will investigate the liturgical and devotional space of Dunfermline. The Architecture of Dunfermline is the aspect which has been most studied until now, but this research offers a fuller study, including pilgrimage, patronage and liturgy. Liturgical and devotional performances for the saint were carried out in church. To understand the development of the cult of a saint, it is necessary to examine the internal space and decoration

---

<sup>56</sup> *Registrum de Dunfermelyn*, xix. For the manuscript of *Registrum de Dunfermelyn* see NLS. Adv. MS. 34. 1. 3A.

<sup>57</sup> *Registrum de Dunfermelyn*, xxiii – xxv.

<sup>58</sup> Alasdair Ross, 'The Bannatyne Club and the Publication of Scottish Ecclesiastical Cartularies', *The Scottish Historical Review*, vol. 85, no. 2 (2006), 202–33.

of the church in relation to the liturgical performance. Scholars mentioned above such as Cruden, Fernie, Yeoman and Fawcett have not considered in detail the internal space of Dunfermline Abbey from the point of view of a spatial interaction with liturgical worship. Therefore, with the aid of these scholars' works focusing on the building at Dunfermline, and McRoberts and Holmes' *Lost Interiors: The Furnishings of Scottish Church in the Later Middle Ages*,<sup>59</sup> Chapter Three will try to recreate the changing internal structure of the church building and its significance c.1100-c.1420.

In the end, these examinations of St Margaret and Dunfermline will contribute to understanding the history of the cult of St Margaret and Dunfermline as a royal cult centre, and its significance. It will be seen what influenced the development of the cult at Dunfermline, how and why the royal cult developed and declined, how the monks of Dunfermline promoted or sustained the cult of the saint, how the liturgical space changed in relation to the development of the cult. It is also noted that this thesis will cover the period between 1070 when Margaret appeared in the history of Scotland through marriage with King Malcolm III, and 1420, the year of the burial of Robert duke of Albany who was the last royal family member to be buried at Dunfermline.<sup>60</sup>

---

<sup>59</sup> David McRobert and Stephen Mark Holmes, *Lost Interiors: The Furnishings of Scottish Churches in the Later Middle Ages* (Edinburgh, 2012)

<sup>60</sup> Boardman, 'Dunfermline as a Royal Mausoleum', 150.

## **Chapter 1. The Miracles of St Margaret and Pilgrimage to Dunfermline**

### **(1) Introduction**

Augustine of Hippo (354-430) argued that the relics of the saints could perform miraculous healings.<sup>1</sup> From a pragmatic point of view, miracles were one of the most effective means for converting pagans to Christianity. Many missionaries chose to prove their relationship with God and God's power through demonstrations of 'faith healing.'<sup>2</sup> These approaches to miracles remained until the early twelfth century when the arguments of non-believers and the ideas of the Judaism and Islam began to subsume the belief in saints' cults. Facing these challenges, theologians such as Peter the Venerable, the Cluniac and abbot of Cluny (1094-1156), argued that in spite of a number of miracles performed in the era of the Old Testament, Christianity was distinguished by unrivalled miracles, which caused non-believers to convert into believers. Peter pointed out the incredible miracles which proved the truth of Christianity: the miracles of Mary, some of which he witnessed; the holy fire that occurred at the Holy Sepulchre on the day of the Resurrection; and those that happened at the sites of relics of the True Cross. Alongside Peter, other theologians such as William of Champeaux (1070-1122) and Peter of Cornwall (1139/1140–1221) criticized Jewish opinions and defended Christianity concerning miracles.<sup>3</sup> In this context and in order to avoid suspicion regarding the truth of miracles, the pope soon developed stricter criteria on which to judge the reliability of miracles. This move highlights the papacy's increasing involvement in the cults of saints from the twelfth century onward. The pope would gain control over the cults of saints by the development of the canonisation process, that is, stricter investigation of

---

<sup>1</sup> Finucane, *Miracles and Pilgrims*, 17-9. For miracles in the time of Jesus and the early Church see H. Van der Loos, *The Miracles of Jesus* (Leiden, 1965); Gerd Theissen, *The Miracle Stories of the Early Christian Tradition*, John Riches trans. (Philadelphia, 1983).

<sup>2</sup> Finucane, *Miracles and Pilgrims*, 20-1; Michael E. Goodich, *Miracles and Wonders: The Development of the Concept of Miracles, 1150-1350* (Aldershot, 2007), 9-10.

<sup>3</sup> *Ibid*, 15-7.

miracles attributed to the candidates. In addition, the right to grant canonisation and its strict process contributed to enhance the status of Rome.<sup>4</sup>

Miracles played a crucial role in increasing the status and fame of a shrine in its early stages. However, the mere occurrence of miracles did not guarantee the successful development, or even the survival, of a cult. As Benedicta Ward has pointed out, success or failure depended on the cult's influence over people rather than the existence of miracles attributed to its saint. She concluded that three crucial factors determined the rise and fall of any given cult. The first was biographers' efforts to bond the miracles with the people. The second was local connections: if the saint had a family or relatives nearby the shrine was naturally more likely to develop. Thirdly, a political factor also contributed to the development of the cult. Consider for example that of St Thomas, who was killed by the knights of Henry II's court.<sup>5</sup> In her research on Melrose Abbey, however, Jamroziak also points out that the most important factor in the success of a medieval religious community was its engagement with the lay society by praying for the devoted lay person, providing them with commemorative services and burial sites.<sup>6</sup>

In addition to these, other factors also affected the development of the cult, as in the case of St Margaret and Dunfermline Abbey. Above all, the effort of the religious community itself was vital in the development of the cult. By arranging events such as the translation of relics or the extension of buildings, the monks could promote the cult or sustain its reputation. Other elements could also affect the success of the cult and the abbey: the easy access of traffic routes; the shrine's function as an economic centre; the presence of full body remains and multiplied shrines and stations produced through the translations of the remains; miracles showing the power of the saint. The rise or fall of the cult of saints also depended upon

---

<sup>4</sup> André Vauchez, *Sainthood in the later Middle Ages* (Cambridge, 2005), 33.

<sup>5</sup> Ward, *Miracles and the Medieval Mind*, 127-31.

<sup>6</sup> Jamroziak, 'Making friends beyond the grave', 324.



pilgrimage to the shrine. Conversely, the popularity of a pilgrimage site reflected the success of the cult.<sup>7</sup>

To assess the development and popularity of the cult of St Margaret at Dunfermline Abbey and beyond, this chapter focuses on the exploration of the miracles attributed to St Margaret and pilgrimage to Dunfermline in the context of the development of the cult by studying the collection of miracles and its collectors, the recipients of St Margaret's miracles, the genres and characteristics of St Margaret's miracles, and pilgrimage to Dunfermline, along with the effort of monks at Dunfermline to promote the cult of St Margaret.

---

<sup>7</sup> The term 'pilgrim' derives from the Latin *peregrinus*, which meant originally a 'foreigner' or a 'stranger' being separated from his/her own community (Webb, *Pilgrimage in Medieval England*, xii; Webb, *Medieval European Pilgrimage*, 2).

## **(2) The collection of miracles and collectors**

Anglo-Norman hagiography was designed for a saint to be accepted, and to establish and sustain a cult in the Post-Conquest era. R. W. Southern argued that ‘after the Conquest, important questions of cults and the proofs of the efficacy of saints and relics required a record to be made of past and present miracles.’<sup>8</sup> However, as Rachel Koopmans suggests, English miracle collectors in the twelfth century might have recorded stories for succeeding generations to remember and pray for them, and were perhaps less concerned about their contribution to sustaining or promoting the cult of saints.<sup>9</sup> In fact, as already noted, the success of the cult depended on its relationship with the laity. In other words, the laity’s interest in the cult and their tendency to circulate stories concerning the cult were crucial points in its development. Pilgrims visited the shrine to perform penance, seek general intercession and favour for good harvest, businesses, family etc. Moreover, they came to the shrine to seek miracles and give thanks to God and to the saint, who performed miracles. Since lower class people often could not read or write, they distributed the stories orally. Therefore, hagiography describing the virtues of a saint would be written not for them but for literate groups, who could later tell these stories to those unable to read. In this context, miracles were a more effective way than a saint’s virtuous life to promote the cult. Therefore, it is reasonable that there would be no miracle collection aimed at or used for a petition for a saint’s canonisation in the twelfth century, with the exception of the collections composed by

---

<sup>8</sup> R. W. Southern, *Medieval Humanism and Other Studies* (Oxford, 1970), 172. Some scholars suggest different opinions from that of Southern. For example, Susan Ridyard argues that ‘the inspiration for post-Conquest hagiography lay...with Norman churchmen who perceived the usefulness of the English saints and who realized that those saints could be successfully utilised only if their history was fully documented and their function effectively publicised (Susan J. Ridyard, ‘Condigna Veneratio: Post-Conquest Attitudes to the Saints of the Anglo-Saxon’ in R. Allan Brown ed., *Anglo-Norman Studies* 9 (1987), 205-6).’ Monika Otter insists that ‘the need for such texts was greatly stimulated by the need to reassert rights and privileges, and generally to re-establish historical continuity, after the disruption caused by the Norman Conquest’, and she argues furthermore that ‘there was also a more general desire to fill in the historiographical gaps, to consolidate in writing what was previously oral or sparsely documented local traditions (Monika Otter, *Inventiones: Fiction and Referentiality in Twelfth-Century English Historical Writing* (Chapel Hill, 1996), 22).’

<sup>9</sup> Rachel Koopmans, *Wonderful to Relate: Miracle Stories and Miracle Collecting in High Medieval England* (Pennsylvania, 2011), 97.

Osbert of Clare, monk and prior of Westminster (d. after 1139). Osbert's *Life of Edward the Confessor* would be the first English collection used to request a canonisation. In spite of this, the collection was more a collection of Osbert's letters, and it does not display the characteristics of later canonisation dossiers such as 'the bulk or notarialese'.<sup>10</sup> In the document relating to the process of canonisation, to convince commissioners, notaries wrote the contents relevant to the miracles in detail: 'names, places, professions, dates, types of illness, lengths of illness, nature of healings, and then, compulsively and insistently, witnesses to all those names.'<sup>11</sup> In the same vein, Turgot's *Life of St. Margaret*, which focused on the virtuous life of St Margaret alongside only one miracle story concerning St Margaret's gospel book,<sup>12</sup> was designed to encourage later followers, particularly literate elite groups, to remember and emulate her life rather than to prepare for the request of canonisation.

The earlier collections were less interested in stories about the laity: consequently, they contained few stories about them. However, collections recorded between c.1140 and c.1200 demonstrate that the attention of collectors had shifted from the stories circulated in their own conversational groups to those told by the laity.<sup>13</sup> In other words, the collections of the early twelfth century seem to 'reflect the experiences and difficulties from cloister monks: ill abbots, ill monks, ill friends and relatives, lawsuits, aggressive nobles, troubled young monks,

---

<sup>10</sup> *Ibid*, 99. For the attempts of canonisation of St Edward see B. W. Scholtz, 'The Canonisation of Edward the Confessor', *Speculum* 36 (1961), 38-60; Edina Bozoky, 'The Sanctity and Canonisation of Edward the Confessor' in Richard Mortimer ed., *Edward the Confessor: The Man and the Legend* (Woodbridge, 2009), 173-86.

<sup>11</sup> Koopmans, *Wonderful to Relate*, 206.

<sup>12</sup> Turgot, *Life of St. Margaret, Queen of Scotland*, ed. William Forbes-Leith (Edinburgh, 1884), 66-8; Walter Bower, *Scotichronicon*, D.E.R. Watt, et al eds., 9 vols. (Aberdeen, 1987-1999) [hereafter, *Chron. Bower*], iii, 79; *ESSH*, ii, 59-88. For the secondary studies on St Margaret and Turgot's *Life of St Margaret* see Valerie Wall, 'Queen Margaret of Scotland (1070-93): Burying the Past, Enshrining the Future' in Anne Duggan ed., *Queens and Queenship in Medieval Europe* (Woodbridge, 1997), 27-38; Lois L. Huneycutt, 'The Idea of the Perfect Princess: The Life of St Margaret in the Reign of Matilda II (1100-18)' in M. Chibnall ed., *Anglo-Norman Studies*, xii (Woodbridge, 1990), 81-97.

<sup>13</sup> The miracle collections composed between c.1140 and c.1200 which Rachel Koopmans has analysed are as follows: the collection relating to miracles on Farne Island, the William Chronicle, the collections for St Æbbe, St Godric, Saints of Hexham, St Oswine, St Cuthbert, St William of York, St John of Beverley, St Wenefred, St Gilbert of Sempringham, St Guthlac, St William of Norwich, St Ætheltryth, St Edmund, St Frideswide, St Edward, St Bartholomew, St Erkenwald, St Ithamar. St Becket, St Anselm, the hand of St James (*Ibid*, 112-38).

thieves, property disputes, lost books, cruel schoolmasters, and so on.’ On the other hand, the collections of the later twelfth century tend to pay attention to tales of the laity such as those of ‘sick children, ill husbands, ill wives, work accidents, shipwrecks, drownings, troubled young women, difficult pregnancies, lost coins, even diseased animals.’<sup>14</sup> This shift of trend might have been relevant to religious houses seeking patronage from the laity. The collectors would not have recorded miracles if they had any doubt. They would utilize their own criteria in their selection and examination of the tales. For example, Benedict of Peterborough, who collected the miracles of St Thomas Becket from mid-1171 to 1173, classified stories into three groups: ‘the miracles which we saw with our own eyes, or we heard from those ill people already healed and their witnesses, or those things we learned from the testimony of religious men, who had seen them with their own eyes.’<sup>15</sup> Benedict sought ‘proofs’, demanded ‘witnesses’, got upset ‘when people failed to tell him their stories’ and even made ‘trips outside of Canterbury to investigate certain miracles.’ His criteria played a key role as an example to other miracle collectors in a period of time before, as discussed below, the canonisation procedure became complicated and strict.<sup>16</sup> Moreover, as Vauchez’s research on the canonisation procedure of Thomas Cantilupe, bishop of Hereford (c.1218–1282, canonised in 1320) found, the canonisation process required further criteria on which to judge the credibility of miracles: being ‘performed by good agents and ordained for the glory of God’, miracles shall ‘strengthen faith’, and be followed by ‘invocation of the name of God.’<sup>17</sup> This seems to correspond to the thirteenth-century trend emphasising ‘the food of the word of God’ for the salvation of Christians by the papal/church Council.<sup>18</sup>

---

<sup>14</sup> *Ibid*, 112-4.

<sup>15</sup> Benedict of Peterborough, *Miracula S. Thomae Cantuariensis*, ed. J. C. Robertson, vol. i (Rolls Series; London, 1875), 7.

<sup>16</sup> Koopmans, *Wonderful to Relate*, 160-1.

<sup>17</sup> Vauchez, *Sainthood in the later Middle Ages*, 496.

<sup>18</sup> Medieval Sourcebook: Twelfth Ecumenical Council: Lateran IV 1215, canon 10 accessed on <http://www.fordham.edu/halsall/basis/lateran4.asp>.

In fact, miracles were investigated more strictly by the collectors in the thirteenth century to meet the strict requirements of the canonisation process. If the examination had satisfactory results, they would be recorded in the collection. The tests were carried out to confirm whether miracles which had occurred in the shrine or in front of the collectors were real or not. Those who had once lost eyesight were asked to name things or identify colour or follow lighted candles. Cripples had to walk around before the collectors.<sup>19</sup> The healing miracles which happened out of the church were examined more strictly, because patients' afflictions could be easily exaggerated. In addition, a few healings happened immediately when the patients visited the shrine of a saint. By medieval standards, it would not be uncommon that healing miracles transpired a certain time later after visiting the shrine. For example, as Finucane pointed out, the collectors of St Wulfstan of Worcester's posthumous miracles recorded that a healing miracle happened all at once and, unlike others, after a delay.<sup>20</sup> To examine miracles which occurred outside shrines more thoroughly, witnesses were necessary. In other words, those who came to report miracles were required to bring friends or family to support their accounts and answer collectors' questions. The witnesses had to give an oath and testify about the miracles which they had observed from beginning to end. The dubious or important cases sometimes led collectors to summon witnesses or order them interviewed by local clergy: on occasion collectors themselves visited to ascertain whether pilgrims' statements were true or not. Some pilgrims brought letters along with their witnesses, because written confirmation was considered more reliable than oral testimony. Apart from an individual pilgrim's efforts to have his/her miracle accepted, bishops and clerics themselves sent collectors testimonials about their local miracles.<sup>21</sup> Since the flow of pilgrims into a church generated income and promoted the cult of a saint, bishops and clerics

---

<sup>19</sup> Finucane, *Miracles and Pilgrims*, 100.

<sup>20</sup> *Ibid*, 76.

<sup>21</sup> *Ibid*, 101. For the inquiry on miracles in the canonisation process see Robert Bartlett, *The hanged man: A story of miracle, memory and colonialism in the Middle ages* (Princeton, 2004).

tried to draw the pilgrim's attention to their local shrines by publishing reports of a number of miracles at their local churches. In this context, the translation of St Margaret in 1180, which was presumably carried out by the monks of Dunfermline themselves, can be understood as coinciding with the development of St Margaret's cult; as a result of it, the demand to provide the shrine with more space, the desire of pilgrims to access the shrine easily, and, in the end, the wish of monks to promote the cult of St Margaret.

In fact, the canonisation procedure was established from the beginning of the twelfth century. For example, when Pope Calixtus II (d.1124) visited Cluny in 1120, he was asked to canonise St Hugh. After reading the text describing the saint's life and miracles, the pope demanded that witnesses be called to answer questions.<sup>22</sup> However, in the last decade of the twelfth century, there was not yet a formal requirement and standard for the text describing the life and miracles of a candidate. Since the procedure was still simple, witnesses were asked just a few basic questions.<sup>23</sup> The development of the examination of miracles began c. 1200 alongside the renovation of the canonisation process during the reign of Pope Innocent III (1198-1216). He made the process of canonisation both more complicated and stricter in stating an uncompromising investigation of miracles, which were, along with the virtue of a candidate, the most important criteria in receiving canonisation. Because he believed that miracles may also possibly have a diabolical origin, he insisted that miracles should be examined more strictly.<sup>24</sup> This approach to miracles and canonisation, on the juridical plane, seems to become more apparent after the Fourth Lateran Council in 1215. The relevant canon was 62 of the Council, which had been initially announced at the synod of Mainz of 813 and already contained in the *Decretum* of Gratian stating, that 'let no one presume to venerate publicly new ones [relics] unless they have been approved by the Roman pontiff.' Although canon 62 did not specifically mention the right of canonisation, as N. Hermann-Masquard has

---

<sup>22</sup> Vauchez, *Sainthood in the later Middle Ages*, 33-4.

<sup>23</sup> *Ibid*, 35; Koopmans, *Wonderful to Relate*, 124.

<sup>24</sup> Vauchez, *Sainthood in the later Middle Ages*, 36-49.

pointed out, the pope's right to approve the cult of new relics meant that he could control the veneration of the relics of 'uncanonised' saints.<sup>25</sup> Moreover, since a relic played a significant role in encouraging the cult relating to the relic and the religious community to house the relic, the control of the cults of new relics could help distinguish significant cults possessing valuable or numerous relics from the lesser-known cults housing less valuable relics.

Robert Bartlett provides an opportunity to see the process of canonisation. In *The Hanged Man*, Bartlett describes an inquiry in 1307 to investigate whether the candidate, Thomas de Cantilupe, bishop of Hereford, who died twenty five years earlier, could be regarded as a saint or not: 'three commissioners, entrusted with the task by Pope Clement V had been empowered to hear testimony about the bishop's life, the general reputation he enjoyed, and the miracles he had performed after death.'<sup>26</sup> As Bartlett points out, many witnesses of the same miracle were summoned to give testimony before the representatives dispatched by the pope, which demonstrates how the process of canonisation was an attempt to examine the miracles with due consideration.

Thanks also to Bartlett, a fifteenth-century manuscript copy of a collection of miracles attributed to Margaret [Madrid Biblioteca Real, MS II. 2097], which had been brought from England to Spain by a Spanish ambassador in the seventeenth century and which remained in Madrid, was discovered. In fact, the collection of St Margaret's miracles had escaped scholars' attention because it had not been edited and placed in a solitary manuscript. The

---

<sup>25</sup> *Ibid*, 29; N. Hermann-Masquard, *Les reliques des saints: formation coutumière d'un droit* (Paris, 1975), 101; Medieval Sourcebook: Twelfth Ecumenical Council: Lateran IV 1215, canon 62 accessed on <http://www.fordham.edu/halsall/basis/lateran4.asp>. At the Fourth Lateran Council in 1215 some Scottish prelates attended: William Malveisin, bishop of St Andrews; Brice, bishop of Moray; Henry, abbot of Kelso; and Walter, bishop of Glasgow. Other prelates did not attend the Council in person. Instead they dispatched their delegates. In 1218 Brice, bishop of Moray visited Rome again along with Walter, bishop of Glasgow, and Adam, bishop of Caithness, in order to obtain absolution from the excommunication imposed on King Alexander II and the whole kingdom of Scotland, which had been incurred by Alexander II's supporting the English barons in their rebellion against the English king (*ESSH*, ii, 405, 431, 435-6; John Dowden, *The Bishops of Scotland*, ed. J. Maitland Thomson, (Glasgow, 1912), 12, 147, 234, 301. For the war against the English king being joined by Alexander II see A.A.M. Duncan, *Scotland: The Making of the Kingdom* (Edinburgh, 1975), 521-5).

<sup>26</sup> Bartlett, *The hanged man*, 1.

composite manuscript contains five items: (1) an interpolated version of the *Vita S. Margarete*, which was originally written by Turgot between 1100 and 1107; (2) a collection of miscellaneous historical material named the ‘Dunfermline Continuator’ by its editor, Donald Watt; (3) the *Miracula S. Margarite Scotorum regine*, ‘The Collection of St Margaret’s Miracles’; (4) Jocelin of Furness’ *Vita S. Valleui abbatis de Melros* written between 1207 and 1214, which is a hagiography of Waltheof, abbot of Melrose (c.1095–1159), the son of earl Simon of Northampton and Matilda, who later married earl David of Huntingdon, the future king of Scots; (5) miscellaneous pieces known as the *Dunfermline Chronicle*, which may have been, as Dauvit Broun has insisted, a source used by John of Fordun’s *Gesta Annalia* compiled c.1363-84. The composite manuscript was copied out during the reign of James III (1460-88),<sup>27</sup> possibly coinciding with mid-fifteenth-century building works commissioned by the abbot at Dunfermline, as discussed in greater detail below.

However, it is not certain when the *Miracula* were collected. Some chapters suggest specific times: miracles mentioned in chapters 9 and 42 transpired in 1180 and 1257 respectively. Chapter 7 mentions the miracle concerning the battle of Largs in 1263. Other chapters merely give hints. For instance, chapter 2 mentions that ‘the body [of St Margaret], as were proper, is kept entombed next to the high altar with great honour to the present day.’<sup>28</sup> Since the tomb mentioned in this chapter was the 1180 shrine, and the relics of St Margaret were still buried there at the moment when the miracle was recorded, this particular

---

<sup>27</sup>Alice Taylor, ‘Historical writing in twelfth-and thirteenth-century Scotland: the Dunfermline compilation’, *Historical Research*, vol. 83 (2010), 229-30; *Miracula*, xxxi-xxxiv. For Waltheof see Helen Birkett, ‘The Struggle for Sanctity: St Waltheof of Melrose, Cistercian in-house cults and canonisation Procedure at the turn of the thirteenth century’ in Boardman and Williamson eds., *The Cult of Saints and the Virgin Mary in Medieval Scotland*, 43-60; Helen Birkett, ‘Promoting Sanctity: The *Vita S. Waldevi*, Canonisation and Cistercian Sainly Cults’ in *The Saints’ Lives of Jocelin of Furness: Hagiography, Patronage and Ecclesiastical Politics* (York, 2010), 201-26. For Dauvit Broun’s argument see Dauvit Broun, ‘A New Look at *Gesta Annalia* Attributed to John of Fordun’ in Barbara E. Crawford ed., *Church, Chronicle and Learning in Medieval and Early Renaissance Scotland: Essays Presented to Donald Watt on the Occasion of the Completion of the Publication of Bower’s Scotichronicon* (Edinburgh, 1999), 20.

<sup>28</sup>*iuxta magnum altare, ut dignum fuerat, usque in presens seruatur cum maximo honore tumulatum* (*Miracula*, 76-7).



miracle happened and was written down between the 1180 translation and the 1250 translation. Chapter 16 states that ‘they tied him [a sailor, William possessed by a demon] up securely and brought him bound to the place where the queen had lain for eighty years.’<sup>29</sup> The period of time between 1180 and 1250 is, of course, only 70 years, but St Margaret had lain in her original tomb in the nave from 1083 until the 1180 translation. Therefore, the tomb mentioned in the chapter could not have been the 1180 shrine. Instead, it was presumably the original tomb in the nave. If that is the case, the miracles would have happened before 1180.

As Bartlett points out, accounts of miracles in the first eight chapters, including the miracle about the battle of Largs, were reliant on eye-witnesses. In addition, the collector of the *Miracula* assures us in chapter eight, ‘I can inform readers categorically that, up to this point, I have placed nothing in this little book except what I have seen with my own eyes. What now follows I have learned from trustworthy information....’ If the author’s account in chapter eight can be accepted, and given the descriptions of miracles in 1257 and concerning the battle of Largs in 1263, the collection was completed after at least 1263.<sup>30</sup> However, if it can be accepted that the collection was completed after 1263, a question, as Bartlett argues, is raised: why does the *Miracula* not mention St Margaret’s canonisation of 1249 and the translation of the saint of 1250-1? Bartlett suggests two possibilities. Firstly, a collector of the thirteenth century might have valued local miraculous cures above the recognition of outside authority such as papal bulls and royal visits. Another possibility is that the earlier miracles had been collected before 1249 and additional accounts were added later,<sup>31</sup> given that it was essential to collect miracles to secure St Margaret’s canonisation.

..... In all things we have avoided the stain of falsehood and made the effort in our account to keep a certain distance from the things that occurred, lest we

---

<sup>29</sup> *Quem firmiter ligauerunt et ad locum quo predicta regina per octoginta annos requieuit ligatum dimiserunt (Ibid, 108-9).*

<sup>30</sup> *Ibid, xxxiv-xxxv, 86-95, 140-5.*

<sup>31</sup> *Ibid, xxxv-xxxvi.*

should presumptuously go beyond the bound of truth, which God forbid! But we certainly wish to proclaim the more manifest miracles in the course of our composition...<sup>32</sup>

This statement emphasizes the effort of miracle collectors not to record untrue stories, which likely illustrates the collectors' awareness of their need to meet the requirements of the canonisation procedure. If that is the case, it is more convincing that the miracles were initially collected in preparation of her 1249 canonisation. Additionally, the *Miracula* itself was perhaps written down c.1263, potentially drawing on earlier written sources such as materials relating to the 1180 translation, which might have been collected by the monks of Dunfermline in preparation.

Alexander II requested that Pope Innocent IV launch a canonisation process for Queen Margaret. The request was conveyed to the pope by David de Bernham, bishop of St Andrews, who attended a General council in Lyon on 24 June 1245.<sup>33</sup> On 27 July 1245 Pope Innocent IV commanded the bishops of St Andrews, Dunkeld and Dunblane to investigate Queen Margaret's life and miracles pertaining to her.<sup>34</sup> On 13 August 1246 the pope sent a letter to the bishops of Glasgow and St Andrews to complain about the investigation reported by the bishops of St Andrews, Dunkeld and Dunblane, informing them that the names and the statements of the witnesses were not included in the report, and instructing them to make further investigation.<sup>35</sup> Under the conditions of strict investigation for canonisation in the thirteenth century, rejection of an enquiry and request for re-investigation was not uncommon.<sup>36</sup> For example, the examination of St Edmund of Canterbury held in 1244 did not

---

<sup>32</sup>.... *Nos autem in omnibus mendacii maculam fugientes, studuimus ex hiis que gesta sunt semper aliquid in relatione nostra retrahere, ne presumeremus-quod absit-modum ueritatis excedere. Hoc pro certo uolentes manifestiora tamen in nostre ordinationis textu enotare miracula, ....(Ibid, 90-1).*

<sup>33</sup> D.E.R. Watt, *Medieval Church Councils in Scotland* (Edinburgh, 2000), 87-8.

<sup>34</sup> *Registrum de Dunfermelyn*, no. 281. Generally speaking, the investigation for canonisation in the thirteenth century was carried out in two aspects, the life and the miracle. The investigation of the first was limited and a few witnesses were examined. On the other hand, miracles attributed to the candidate were tested completely (Vauchez, *Sainthood in the later Middle Ages*, 47; Bartlett, *The hanged man*).

<sup>35</sup> *Registrum de Dunfermelyn*, no. 285.

<sup>36</sup> Vauchez, *Sainthood in the later Middle Ages*, 33-57.

meet Innocent IV's demands, and he commanded the commissioners to collect detailed and substantial evidence of four or five miracles rather than bring inadequate evidence together.<sup>37</sup> Under the supervision of 'H.', cardinal priest of St. Sabina in Rome, an examination of the life and miracles of St. Margaret was conducted. On 16 September 1249 the pope eventually declared her canonisation.<sup>38</sup>

As mentioned above, according to Rachel Koopmans's analysis of English miracle collections, while the collections of the early twelfth century seem to focus on the tales of cloister monks, the collections of the later twelfth century tend to pay attention to the stories of the laity. If the proviso that these trends could be adapted to the miracle collection of St Margaret can be accepted, it might be suggested with caution when the miracles occurred. In chapters 10, 11, 14, 15, 28, 32, 34, 36 and 37 of Bartlett's edition, monks experienced miracles. In chapter 41, a priest received a miracle.<sup>39</sup> The miracle in chapter 31 happened to 'Gregory, a prior of Dunfermline', who, as Bartlett suggests, may be Prior Geoffrey who was abbot from 1238 to 1240.<sup>40</sup> Therefore, it might be suggested cautiously that adapting Koopman's criteria, with the exception of the miracle of Chapter 31 these miracles noted above perhaps happened around the mid-twelfth century, presumably, prior to 1150 when Dunfermline Abbey became the parish church. Namely, it was the year 1150 when 'David's church' was consecrated<sup>41</sup> and, in consequence, the 'nave' of 'David's church' could be used as a parochial church. As a result, more lay visitors could come to the church. It also assumes that the laity had little opportunity to receive miracles attributed to St Margaret until the abbey became the parish church in 1150. Additionally, miracles occurring before c.1150 and their subsequent recording might have played a role in supporting the building scheme of David I. In other words, through the collecting of miracles the monks at Dunfermline Abbey

---

<sup>37</sup> *Registrum de Dunfermelyn*, no. 279.

<sup>38</sup> *Ibid*, no. 290.

<sup>39</sup> *Miracula*, 94-97, 96-99, 106-7, 122-125, 128-129, 130-133, 132-135, 134-5, 138-141.

<sup>40</sup> *Ibid*, 126-7, note. 68.

<sup>41</sup> *A Scottish chronicle known as the Chronicle of Holyrood*, ed. M. O. Anderson (Edinburgh, 1938), 35.

presumably intended to display the holy power of St Margaret and, in consequence, to promote the cult of the saint in service of David's building plan at Dunfermline. The pattern of miracles - the recipients seemingly all monks - is likely to reflect not only fewer lay benefactions to Dunfermline Abbey but also David's strong patronage to the abbey and the effort of monks at Dunfermline to encourage the cult of St Margaret.

Most chapters of the *Miracula* were written by an anonymous author or authors. However, some chapters indicate that a monk of Dunfermline recorded the chapters: 'I have learned from trustworthy informants, who are still monks in our church (ch. 8)'; 'I myself, who am telling you about this miracle, and two of the brethren with me, came cautiously to the sick man...(ch. 16); the miracle which occurred 'in the dining hall' was testified by 'us who were there (ch. 22)'; a miraculous cure was seen 'as we were celebrating the service (ch. 23).'<sup>42</sup> Therefore, the miracles of St Margaret occurring before c.1150 were perhaps recorded by various anonymous authors - the sacristan, who maintained 'all ornaments, utensils and furnishing of the church'<sup>43</sup> may also have kept the relics and collected/recorded miracles. However, given the cohesion and style of the composition of the collection, as Bartlett points out,<sup>44</sup> the collection seems to have been written or re-written c.1263 by one author. If that is the case, miracles occurring before c.1150 were likely copied or edited by a monk in the mid-thirteenth century, when the petition for the canonisation of St Margaret was prepared. In addition, a monk generally sat near the shrine not only to record miracles happening there but also to collect the offerings.<sup>45</sup> However, the evidence from these four chapters (8, 16, 22, 23) suggests that miracles of Dunfermline were not collected in this manner.

Generally speaking, miracles attributed to a candidate and his/her life were taken into consideration in the canonisation processes. The 'depositions at the process of canonisation

---

<sup>42</sup> *Miracula*, xxxvii, 91-3,108-9, 116-7, 118-9.

<sup>43</sup> *The Monastic Constitutions of Lanfranc*, ed. David Knowles and Christopher N. L. Brooke (Oxford, 2002), 122-7.

<sup>44</sup> *Miracula*, xxxvii.

<sup>45</sup> Ward, *Miracles and the Medieval Mind*, 94.

distinguished according to their content (1185-1417)' analyzed by André Vauchez has found that the candidate's biography held relatively little value in the investigation of a candidate for canonisation in the thirteenth century. The commissioners entrusted by the pope were more interested in miracles associated with candidates. On the other hand, from the last third of the thirteenth century the emphasis on miracles became less common, so that after 1300 over 70% of dispositions at the processes were relevant to the moral life of a candidate.<sup>46</sup> Thus the last third of the thirteenth century seems to mark a turning point in the process of canonisation. In addition, according to Vauchez's study on the process of canonisation applied between 1185 and 1417, in five of seven processes held between 1185 and 1300, and in only four of twelve between 1301 and 1417, at least 10% of miracles were performed after the candidate's death.<sup>47</sup> This shift can also be understood in the context of the development of the process of canonisation from the fourteenth century, the sainthood of a candidate was determined by a candidate's reputation and life, not necessarily candidate's miracles. Given that this trend appeared in the last third of the thirteenth century, it might explain why no more miracles were collected in the *Miracula* of St Margaret after 1263. Also worthy of note is that since St Margaret had already been canonised, the monks of Dunfermline might simply not have needed to collect miracles any more.

As for St Margaret, she died in 1093 and her process of canonisation began in 1245. Given that canonisation processes in the thirteenth century put the value of the miracles above the life of a candidate, it is natural to think that the miracle collection of St Margaret played a significant role in the process. Apart from this trend of the thirteenth century, it was inevitable for the commissioners to focus on the miracles, because St Margaret died one and a half centuries before the process was carried out and, in consequence, it was not possible to summon witnesses to testify about her life and reputation. Moreover, as far as the *Miracula*

---

<sup>46</sup> Vauchez, *Sainthood in the later Middle Ages*, 500-1.

<sup>47</sup> *Ibid*, 502-3.

were concerned, every miracle attributed to St Margaret in the collection happened after her demise. This corresponds with the trend of thirteenth-century canonisation processes emphasising miracles performed in the lifetime of a candidate rather than miracles occurring after his/her death. Given that people who experienced miracles were required to attend the inquiry as witnesses, the miracles performed during St Margaret's lifetime could not be used as reliable evidence. This might be one of the reasons why the miracle collection of St Margaret contained more relatively recent tales.

### **(3) The recipients of St Margaret's miracles**

The background of a saint determined the proportion of gender and social class participating in the cult. Regarding gender participation, of 44 persons receiving miracles in the *Miracula* of St Margaret, 17 are females and 27 are males.<sup>48</sup> The proportion of women and men (39.5% to 60.5%) was not atypical, because Finucane's research on the records of the posthumous miracles of seven English saints shows that of 1,933 English pilgrims, 61% were men and 39% were women. The same ratio (61% men, 39% women) was also found in the analysis of 430 pilgrims from two French cults.<sup>49</sup> As a female saint, St Margaret might have been expected to perform miracles associated with difficulties in pregnancy and childbirth. Even though the *Miracula* of St Margaret make no mention of miracles involving pregnancy and childbirth, there is some evidence indicating the use of St Margaret's 'sark' in royal childbirth, as discussed in Chapter Two. In spite of St Margaret's aid in childbirth, the shrine of the saint was still predominantly visited by males, as were those of other cults. However, taking out the nine monks, a prior and three priests from the male participants,<sup>50</sup> more female lay (17 persons) than male lay (14) visited the shrine. Clearly, St Margaret appealed to female laity.

Other cults were also dominated by females. For example, the cult of St Godric of Finchale (c.1065-1170), a woman who had never been formally canonised, was so popular with females that over two third of pilgrims were women. The reason for this was that the majority of St Godric's pilgrims were both local and of the lowest social class, and from this

---

<sup>48</sup> Chapter 8 of the *Miracula* states that thirteen men and women including 'a paralytic man' and 'a dumb person' were cured on the same night (*Miracula*, 90-1). For precision, a dumb person unidentified the sex and other persons mentioned in chapter 8 are excluded from the total number miracles recipients.

<sup>49</sup> Finucane, *Miracles and Pilgrims*, 142-3. The seven English saints are: Sts Godric, Cuthbert, Frideswide, Wulfstan, Becket, Simon de Montfort and William of Norwich. The two French cults are Edmund Rich's shrine at Pontigny and Louis of Toulouse.

Nine monks	Chs. ( <i>Miracula</i> ) 10, 11, 14, 15, 28, 32, 34, 36, 37
One prior	31
Three priests	20, 38, 41

class most were women. About two-thirds of 108 miracles attributed to St Frideswide (c.650-727) at the Augustinian canons' priory of St Frideswide in Oxford, who was also a non-canonised female saint, happened to women. Local women might have been attracted to the local cult of the Saxon princess.<sup>51</sup> The cult of St Æ bba of Coldingham's Benedictine Priory (c.615-683), who was a princess of the kingdom of Northumbria, abbess of St Æ bba's Head in Berwickshire and a pre-congregation saint,<sup>52</sup> also demonstrates a similar pattern to that of these two cults. Of the 42 recorded individuals who received benefit from St Æ bba of Coldingham (c.615-683), 26 (62%) were female and 16 (38%) male.<sup>53</sup> Just as St Margaret helped women in pregnancy and childbirth, so St Æ bba was involved in the healing of a newborn baby: 'A poor little woman with her newborn son kept vigil for two days at the tomb of the venerable virgin..... and opened the son's hand, which had been contracted into a fist, with the arm dried up and stretched to his chest.....'<sup>54</sup>

On the other hand, the cult of Simon de Montfort (d.1265), whose remains were buried at Evesham Abbey, was placed in the first rank in terms of the high proportion of male pilgrims to female. In particular, the cult was so attractive to the noble class that the number of noble pilgrims was beyond that of any other cult including Becket's. In addition, Simon's pilgrims included more who were high-ranking clerics. These patterns could be explained by Montfort's life. Since he was a significant political figure, and as a consequence, had a strong

---

<sup>51</sup> Finucane, *Miracles and Pilgrims*, 126-9. For the cult of St Frideswide see Simon Yarrow, 'The Miracles of St Frideswide of Oxford' in *Saints and their Communities: Miracle Stories in Twelfth Century England*, 169-89; John Blair, 'Frithuswith (d.727)', *Oxford Dictionary of National Biography* (Oxford University Press, 2004) [hereafter *ODNB*], accessed on <http://www.oxforddnb.com/view/article/10183>. For St Godric see Victoria Tudor, 'Godric of Finchale [St Godric of Finchale] (c.1070-1170)', *ODNB* accessed on <http://www.oxforddnb.com/view/article/10884>.

<sup>52</sup> A pre-congregation saint was declared to be a saint by a local bishop, patriarch, popular devotion etc. before the canonisation procedure was established from the beginning of the twelfth century onwards.

<sup>53</sup> *Miracula*, xii-xiv, xxiii.

<sup>54</sup> *Ibid*, 58-9.



relationship with high profile members of both religious and secular circles, it is not surprising that a number of nobles and upper ecclesiastics were led to his tomb.<sup>55</sup>

The cult of St Thomas was also an overwhelmingly male-focused one. Of 638 individuals involved in miracles recorded in the *Materials for the History of Thomas Becket* by William Canterbury and Benedict of Peterborough in the last quarter of the twelfth century, only 174 were female.<sup>56</sup> According to Finucane's explanation of miraculous healing in relation to gender, more women than men would have suffered from hysterical debilities symptomised by paralysis, blindness, and rheumatic arthritis. Of course, only women suffered the trauma of childbirth. Women were affected by malnutrition more than men on occasions of food shortages, because men and children were generally fed first.<sup>57</sup> Given these circumstances, females were likely to need more miracles than males. However, the reality was quite different, perhaps due to the geographical issue discussed below. Finucane's explanation offers the possibility that those who suffered from infirmities such as hysterical disabilities, paralysis, blindness and rheumatic arthritis might have been less attracted to St Thomas. Additionally, the miracles attributed to St Thomas in the collections may consist of a higher proportion of non-healing miracles than other cults, because compared to women,

---

<sup>55</sup>Finucane, *Miracles and Pilgrims*, 135. For the cult of Simon de Montford see John M. Theilmann, 'Political Canonization and Political Symbolism in Medieval England', *The Journal of Britain Studies*, vol. 29, no. 3 (1990), 241-66; Simon Walker, 'Political Saints in Later Medieval England' in R.H. Britnell and A.J. Pollard, eds., *The McFarlane legacy: studies in late medieval politics and society* (Stroud, 1995) 77-106. For the political martyrs in late Medieval England see Danna Pirovandsky, *Martyrs in the Making: Political Martyrdom in Late Medieval England* (New York, 2008). Unlike the case of Simon de Montfort, the miracle collection of St Thomas Cantilupe demonstrates that relatively fewer upper-level churchmen and nobility experienced the miracles attributed to that saint. In addition, the saint's pilgrims contained a tiny proportion of pilgrims from the lower clergy, and 'relatively fewest miracle-touched priests, monks or friars' of all the cults which Finucane studied. Less involvement of the lower clergy with the cult of St Cantilupe presumably stemmed from the excommunication of Cantilupe by the Archbishop of Canterbury. Some church men might have been reluctant to get involved with the cult of an excommunicated man (Finucane, *Miracles and Pilgrims*, 136-7; Finucane, 'Cantilupe as Thaumaturge: Pilgrims and Their 'Miracles' in Meryl Jancey ed., *St Thomas Cantilupe, Bishop of Hereford: Essays in His Honour* (Hereford, 1982), 137-44).

<sup>56</sup> *Material for the History for Thomas Becket*, eds. Robertson, 2 vols.

<sup>57</sup> Finucane, *Miracles and Pilgrims*, 148.

more men experienced non-healing miracles such as rescue at sea, escape from captivity and recovery from war wounds.<sup>58</sup>

Geographical issues might also have influenced the proportion of pilgrims' gender: men found it easier to make a long trip than women. According to Finucane, in cases of journeys over 45 or 50 miles from their homes, the participation rate of female pilgrims fell sharply, and that of males remained about the same.<sup>59</sup> Given that travelling over 30 miles per day was not easy for even an experienced traveller in the Middle Ages,<sup>60</sup> pilgrims would have needed two days to reach shrines which were 45 or 50 miles away from their home - if able-bodied. In this case, to reach their destinations and return home would have required a journey of at least four or five days. Women might have been able to make a one or two day trip, but fewer women could have managed a journey to shrines more than 20 miles away. As far as the cult of St Thomas Cantilupe before 1287 is concerned, a majority of miracles registered in the miracle collection happened to women who lived in the vicinity of the shrine, their miracles were mainly healings of physical illnesses, and most healings occurred at the shrine.<sup>61</sup> At the early stage of the cult, the enthusiasm of locals toward the cult was strong. In consequence, the majority of the pilgrims would have been local persons, of whom female pilgrims overwhelmingly predominated over male.

Identifying and analysing pilgrims by their hometowns can lead us to an understanding of how far the cult spread. In the *Miracula* of St Margaret, 31 individuals were identified by where they were from.<sup>62</sup> Of these 31 cases, nine were monks, one a prior of Dunfermline Abbey, and three priests. Of nine coming from Dunfermline and its vicinity, six were females and three males.<sup>63</sup> In particular, in four cases the terms 'local' and 'Dunfermline' were

---

<sup>58</sup> *Ibid*, 148-9.

<sup>59</sup> *Ibid*, 176.

<sup>60</sup> Sumption, *Pilgrimage*, 176.

<sup>61</sup> Finucane, *Miracles and Pilgrims*, 176.

<sup>62</sup> *Miracula*, xl-xli.

<sup>63</sup>

applied all to women<sup>64</sup> suggesting that they were from the town of Dunfermline itself. On the other hand, male visitors travelled from Wemyss, Gellad in western Fife<sup>65</sup> and Inverkeithing (chs. 7, 18, 20) five to fifteen miles distant. Although the number of cases might not be enough to generalize, the figure may demonstrate that local females visited the abbey more than local males, and that male pilgrims came from relatively more distant villages - but still hinterland - than those of females. Five individuals (female: chs. 4, 35, 42; male: chs. 16, 21) came from other regions of Scotland including Aberdeen, Galloway and Lothian, and, significantly, seven (female: chs. 1, 6, 12, 17, 29, 39; male: ch. 23) were from England. St Margaret's attraction to the English might have derived from the saint's lineage as a Saxon princess. The geographical pattern of miracles indicates that the cult of St Margaret was local, with limited regional influence up to 100 miles away such as Aberdeen (chs. 16, 35), Galloway (ch. 21) and Northumbria (chs. 12, 17), and over 300 miles away such as Bury (ch. 1) in at least one exceptional case. As with French cults, a large number of pilgrims lived within 35 miles of a shrine, while 65% of the pilgrims at Dunfermline Abbey came from less than 35 miles from the church,<sup>66</sup> which would mean a two or three days trip to return home after visiting the shrine. In this respect, therefore, the cult of St Margaret was a local and regional one.

However, excluding nine monks and a prior of Dunfermline from the list, of 21 recipients - including priests - identified by hometown, nine recipients were from Dunfermline and its hinterland; five were from further afield of Scotland; and seven came from England.<sup>67</sup> Thus, it can be said that the cult of St Margaret was not only attractive to

Six females	Chs. ( <i>Ibid.</i> ) 3, 6, 9, 19, 25, 33
Three males	7, 18, 20

<sup>64</sup> *Ibid*, chs. 3, 6, 9, 19.

<sup>65</sup> The place is now obscure (Ae. J. G. Mackay, *A History of Fife and Kinross* (Edinburgh and London, 1896), 2).

<sup>66</sup> *Ibid*, xli.

<sup>67</sup>

The number of recipients	Location identified by hometown	Chs. ( <i>Miracula</i> )
--------------------------	---------------------------------	--------------------------

local persons but also was spread throughout Scotland and down to England. The distribution of St Margaret's relics to Edinburgh, Westminster (after Edward I's invasion of Scotland) and Durham (after 1346),<sup>68</sup> and probably St Margaret's hospital at Huntingdon<sup>69</sup> also show that the cult of St Margaret was spread throughout England. Concerning St Margaret's hospital at Huntingdon, just as Louis IX gifted Alexander III with St Edmund of Abingdon's relics secured at the saint's translation in 1247,<sup>70</sup> so the translations of 1180 and 1250 may have seen St Margaret's relics gifted to important rulers/churches in England and abroad. St Margaret's hospital at Huntingdon may have been one of the recipients of the relics. Moreover, from the other point of view, the proportion of three female lay to two male coming from further afield around Scotland and six female lay to one male from England demonstrates female lay dominance.

Also worthy of note is the competition of cults shown in St Margaret's miracle stories relating to two women, who visited several shrines before coming to Dunfermline: a Northumbrian woman who had swallowed lizards visited 'nearly all the shrines of the saints in England (ch. 17)'; an English woman suffering from a tumour on her arm went to 'France, and wherever she had heard that martyrs, confessors, and holy virgins were working great deeds in Christ.....she also went to the shrine of the blessed apostles Peter and Paul....(ch. 1).' In fact, as Diana Webb has demonstrated, it was not uncommon that a pilgrim who had visited one shrine but not secured a cure was often urged to go to more potent saint's relics or

9 (42.9%)	Dunfermline and its hinterland	3, 6, 7, 9, 18, 19, 20, 25, 30
5 (23.8%)	Further afield of Scotland	4, 16, 21, 35, 42
7 (33.3%)	England	1, 6, 12, 17, 23, 29, 39

<sup>68</sup> *Calendar of Documents relating to Scotland*, ed. J. Bain, 5 vols. (Edinburgh, 1881-88) [hereafter, *CDS*], v, no. 494; G. Watson, 'The Black Rood of Scotland', *Transactions of the Scottish Ecclesiological Society*, ii (1909), 28-47; L. Rollason, 'Spoils of War? Durham Cathedral and the Black Rood of Scotland' in Rollason and Prestwich eds., *Battle of Neville's Cross, 1346* (Stamford, 1998), 57-65; Michael Penman, 'The Scots at the Battle of Neville's Cross, 17 October 1346', *The Scottish Historical Review*, 80 (2001), 176, n. 57.

<sup>69</sup> This was dedicated to the saint and founded by Malcolm IV, earl of Huntingdon as well as the king of Scotland (*Accounts and Papers relating to Corporate offices and charitable Funds*, vol. 45 (1834), 292).

<sup>70</sup> *CDS*, v, no. 494; Penman, 'Royal piety in thirteenth-century Scotland', 24-5.

shrines where visions had been seen.<sup>71</sup> In the case of these two women, although Dunfermline was not their initial destination while they were seeking healing, they were led to Dunfermline and cured of their illnesses. The cult of St Margaret therefore, at least occasionally, triumphed over other cults in terms of cult competition.

In the *Miracula* of St Margaret, nine monks and a prior of Dunfermline Abbey experienced miracles attributed to St Margaret, a crucial reason why more men than women gained St Margaret's aid. These monks and a prior received miraculous healings, spiritual help and a vision of St Margaret.<sup>72</sup> Three secular clergy also appear in the *Miracula*: a clerk called William of Inverkeithing (ch. 20); a clerk called Robert, the son of a knight (ch. 38); and a priest called Donald (ch. 41). It is also suggested that since monks of Dunfermline Abbey could receive St Margaret's power relatively easily, they might have benefited three times as much as the secular clergy. Apart from nine monks, a prior and three secular clerics, 32 individuals who experienced miracles attributed to St Margaret were laity including a noblewoman; a noble man; a knight; a miller; sailors; a carpenter; a painter; servant girls; a labourer; and a merchant.<sup>73</sup> From the point of view of social class and status, Finucane has

<sup>71</sup> Webb, *Pilgrimage in Medieval England*, 50-8.

<sup>72</sup>

Types of miracles	Chs. ( <i>Miracula</i> )
miraculous healings	10, 11, 14, 15, 31, 32, 34
spiritual help	28, 37
a vision of St Margaret	36

The *Miracula*'s chapter 34, which is about the miracle of the novice Adam, states that: 'a monk who had often experienced the favours of St Margaret advised him to go to her tomb and pray devoutly for his recovery. He replied that he dare not do this, since if his master knew, he would denounce him derisively before them all as moved by hypocrisy.' The novice Adam was required to secure permission to go to the tomb at night (*Ibid.*, 130-1). The life of a novice and his relationship with his master demonstrated by the case of the novice Adam seems to correspond with the instruction of *The Monastic Constitutions* of Archbishop Lanfranc of the Benedictine cathedral priory of Canterbury (c.1005-1089) which comprised of a liturgical directory and a description of the administration of the monastery along with other essential regulations (*The Monastic Constitutions of Lanfranc*, 156-7).

<sup>73</sup>

Social status of the lay recipients	Chs. ( <i>Miracula</i> )
noblewoman	13
noble man	21
knight	7
miller	27
sailor	16, 40

insisted that nearly two-third of English pilgrims (1,933) were men (61%), almost a third of all English pilgrims were lower class men and another third were lower class women. In other words, most female pilgrims (86%) were from lower class, with a little more than half of the men (56%) from the same class.<sup>74</sup> At Dunfermline, just three nobles (chs. 7, 13, 21) benefited from St Margaret’s power. Of 17 female pilgrims only one (ch. 13) was of the upper class, and of the 14 male lay pilgrims just two (chs. 7, 21) were of the noble class. Of 32 lay pilgrims,<sup>75</sup> a large majority of miracles attributed to the saint happened to the lower class. St Margaret’s care for the poorest can be seen in a miracle story of the *Miracula* mentioning that the saint is ‘already a lover of the poor, consoler of the sorrowful, supporter of widows and orphans.’<sup>76</sup> Turgot also relates Queen Margaret’s generosity to the poor, saying that she washed the feet of the poor and fed them, and that the poor were always encouraged to flock to her and she distributed to them all she brought.<sup>77</sup> It is also impressive that nearly 31% of miracles occurring to the laity happened to young people, and that in five miracles young pilgrims were accompanied to Dunfermline Abbey by their parents.<sup>78</sup>

In summary, the miracles of St Margaret demonstrate five characteristics. Firstly, monks of Dunfermline Abbey received St Margaret’s aid relatively easily, or their experiences were presumably easily recorded. St Margaret’s aid to monks may have happened before 1150, which is likely to reflect the cult’s focus on monks and on securing strong royal patronage at that time. Secondly, ignoring the number of clergy, female laity

carpenter	24
painter	22
servant girl	12, 42
labourer	18
merchant	23

<sup>74</sup> Finucane, *Miracles and Pilgrims*, 143.

<sup>75</sup> 32 lay recipients of St Margaret’s miracle include 17 females, 14 males and one person of unknown sex.

<sup>76</sup> *semper amatrix pauperum, consolatrix desolatorum, sustentatrix uiduarum et orphanorum (Miracula, 80-1).*

<sup>77</sup> Turgot, *Life of St. Margaret, Queen of Scotland*, 61, 55.

<sup>78</sup> *Miracula*, chs. 1, 2, 6, 12, 13, 21, 26, 30, 33, 42; 12, 13, 26, 30.

predominated over male. In this respect, St Margaret as a female saint was attractive to females. Thirdly, the cult of St Margaret looks like a regional cult as long as monks and a prior of Dunfermline are included in the list of miracle recipients. However, excluding them from the list, it appears that the cult was spread throughout Scotland and even down to England, and could not be reputed as a regional cult. Fourthly, a small proportion of the nobles on the list of miracle recipients may have reflected St Margaret's generosity to the poor. In addition, almost one-third of lay pilgrims were young people, which communicate St Margaret's approach to raising her children as a mother. That is, St Margaret seems to have raised her children to be pious, as David Knowles defined the Scottish royal court in the time of Queen Margaret and her children as a 'nursery of saints'.<sup>79</sup>

---

<sup>79</sup> Knowles, *The Monastic Order in England*, 242; Baker, "A Nursery of Saints", 138-40.

#### **(4) The genres of St Margaret's miracles**

Finucane's research has been reputed as 'the clearest original of the scholarly achievement' of the late twentieth century.<sup>80</sup> By focusing on the medieval cult of saints and classifying miracles into categories, his research attempts to provide an understanding and an explanation of medieval miracles. Pointing out that about 90% of the posthumous miracles examined in nine cults were associated with miraculous healing, and that some medieval collectors sorted miracles by type of cured illness, Finucane generally follows their approaches, and categorizes miracles into two major groups: healing miracles and non-healing miracles. The healing miracles can be divided into 11 subcategories.<sup>81</sup> The non-healing miracles included 'escapes from captivity, recovery of lost or stolen objects, safety during war, the cures of animals, survival in storms at sea or the perils of flood, famine or fire, transformations of substance such as water to beer or milk, spontaneous lighting or relighting of candles.'<sup>82</sup>

---

<sup>80</sup> Robert Bartlett, 'The Hagiography of Angevin England' in P. R. Cross and S. D. Lloyd eds., *Thirteenth Century England*, V (Woodbridge, 1995), 45.

<sup>81</sup> These are the subcategories: (i) 'unqualified illness, which includes all ailments with very general symptoms: being bed-ridden and disabled, or simply 'paralysed' without further qualification or 'paralysed' on one side'; (ii) cure of illness in 'specific organs or areas of the body' such as 'stone, flux, dysentery, fever, toothache, insomnia, cough and so on'; (iii) cure of 'impaired locomotion or articulation' like cripples and the lame; (iv) Gout and dropsy; (v) 'suppurative, open sores and swelling, tumours, ulcers, abscess with flow of pus, fistula, quinsy, scrofula and leprosy'; (vi) pregnancy and childbirth; (vii) blindness; (viii) mental affliction; (ix) accidents - 'being drowned, smothered, burnt or injured in falls from trees and rooftops'; (x) intentional violence - 'the mutilations and wounding of tavern brawls, robberies with assault, ordeals by combat, attempted suicides, assaults on royal officers, attempted murders, all the usual atrocities of medieval warfare and domestic vengeance'; (xi) miraculous cures relating to apparition [vision] (Finucane, *Miracles and Pilgrims*, 103-111). Other scholars such as Van der Loos and Gerd Theissen have also attempted to suggest the classification of miracles, focusing on the miracles which had happened in the early Christian tradition. Van der Loos has divided miracles into two categories, healing and nature miracles, along with 19 subcategories as follows: (i) the healing of the possessed; (ii) the blind; (iii) the paralytics; (iv) the lepers; (v) a man with dropsy; (vi) the woman with the issue of blood; (vii) the woman bowed together; (viii) the deaf man with a speech defect; (ix) the centurion's servant at Capernaum and of the nobleman's son; (x) Peter's mother-in-law; (xi) Malchus' ear; (xii) the resurrection of the dead; (xiii) the miracle at the wedding at Cana; (xiv) the miraculous feeding; (xv) the stilling of the storm; (xvi) Jesus' walking on the water; (xvii) the miraculous catches of fish; (xviii) the account of the stater; (xix) the cursing of the fig tree (Van der Loos, *The Miracles of Jesus*). Gerd Theissen has analysed the Gospel miracles 'from the synchronic, diachronic and functional points of view', and divides them into six patterns: 'exorcisms, healings, epiphanies, rescue miracles, gift miracles and rule miracles (Theissen, *The Miracle Stories of the Early Christian Tradition*, 19).

<sup>82</sup> Finucane, *Miracles and Pilgrims*, 111-2.



On the other hand, Bartlett has sorted the miracles of St Margaret using a different method from that of Finucane. Due to the limited number of St Margaret's miracles examined by Bartlett, this is understandable. The miracles in the *Miracula* are classified as follows: cures of paralysis and strokes; insanity and possession; dumbness; swellings; toothache; swallowing lizards; blindness, and 'moral miracles, in which the saint appeared to lead monks of Dunfermline to the right way. The remaining miracles are categorized in 'others', which included 'cures of dropsy, elephantiasis, abscess, fever, flux, and missing finger-nails; saving from a fall, the threat of shipwreck, and the burns of the ordeal iron; and one unspecified 'serious illness''.<sup>83</sup> Of 45 miracles, the category of non-healing miracles consisted of three moral miracles received by monks who intended to abandon their vows, with St Margaret appearing in a vision to another (chs. 28, 37; 36);<sup>84</sup> victory at the battle of Largs in 1263; missing finger-nails; saving from a fall, burns of the ordeal iron and the threat of shipwreck (chs. 7, 15, 22, 24, 40).<sup>85</sup> Thus, almost 18% of St Margaret's miracles were non-healing. According to Finucane's analysis of the cults of saints, almost one tenth of collected miracles were involved with non-healing events.<sup>86</sup> In this context, the ratio of non-healing miracles attributed to St Margaret exceeds the average. The relatively high ratio might be because of three occasions (chs. 28, 36, 37) in which St Margaret encouraged these monks in spiritual terms. This kind of miracle is rarely found in other cults of saints.

Table 1. Types of ailment

Ailment	Number of healing	Percentage
Paralysis and strokes	11	24
Insanity and possession	6	13
Dumbness	4	9

<sup>83</sup> *Miracula*, xxxix.

<sup>84</sup> *Ibid*, 122-125, 134-5, 132-.5.

<sup>85</sup> *Ibid*, 86- 89, 106-7, 116-7, 118-9, 138-9.

<sup>86</sup> Finucane, *Miracles and Pilgrims*, 111.

Swellings	4	9
Toothache	3	7
Swallowing lizards	2	4
Blindness	2	4
Moral miracles	3	7
Others	10	22
Total	45	

In general, the registered miracles indicate that men experienced more non-healing miracles than women, because men had more occasions to encounter dangerous moments such as escapes from captivity, safety during war, storms at sea or the perils of flood. In particular, upper class men top such lists in terms of receiving non-healing miracles. One reason for that may be that the upper class people, eager to separate themselves from lower class persons suffering from ailments, were reluctant to accept or report their physical infirmities. Another possibility is that the nobles had alternative sources of healing, rendering miracles unnecessary.<sup>87</sup> In other words, the nobility could get proper medical care.<sup>88</sup>

In the early Middle Ages, the cause of disease was believed to be spiritual sin.<sup>89</sup> However, this did not mean that the sick could not get medical care. The Rule of St Benedict instructed care for the sick and the old:

Before and above all things, care must be taken of the sick....Let a cell be set apart for the sick brethren, and a God-fearing, diligent, and careful attendant be appointed to serve them. Let the use of the bath be offered to the sick as often as it is useful.....also let the use of meat be granted to the sick and to the very weak for their recovery.... (Holy Rule ch. 36) ..... let their [the old] natural weakness be always taken into account and let the strictness of the Rule not be kept with them in respect to food, but let there be a tender regard in their behalf and let them eat before regular hours (ch. 37).<sup>90</sup>

<sup>87</sup> *Ibid*, 144-9.

<sup>88</sup> Finucane, *Miracles and Pilgrims*, 64-6.

<sup>89</sup> Ronald L. Numbers and Darrel W. Amundsen, *Caring and Curing: Health and Medicine in the Western Religious Tradition* (New York, 1986), 76.

<sup>90</sup> *Infirmorum cura ante omnia et super omnia adhibenda est, ..... Quibus fratribus infirmis sit cella super se deputata et servitor timens Deum et diligens ac sollicitus. Balnearum usus infirmis quotiens expedit offeratur.....*

Following this instruction, Benedictine monasteries had their own infirmaries to care for sick inmates and sometimes lay people living near the community.<sup>91</sup> Archbishop Lanfranc also mentioned care of the sick. Lanfranc's *Constitutions* describes the infirmarer thus:

the brother to whom the care of the infirmary is given, and who is set to serve the sick, shall have his own cook and separate kitchen, if the plan of the buildings and the resources of the house allow, so that he may be able to prepare what is necessary for the sick at the right times.<sup>92</sup>

Canon 22 of the Lateran IV Council in 1215, which announced that 'before prescribing for the sick, physicians shall be bound under pain of exclusion from the Church, to exhort their patients to call in a priest, and thus provide for their spiritual welfare',<sup>93</sup> demonstrates that the sick could be treated by physicians.

These approaches to medical care reflect the establishment of hospitals.<sup>94</sup> Dunfermline Abbey also had its own infirmary within its precinct, probably the area south of the abbot's house near the modern-day Dunfermline Carnegie Library - so, the infirmary could be accessible to burgh and laity by the present-day Abbot Street and St Margaret Street, as

---

*Sed et carniū esus infirmis omnino debilibus pro reparatione concedatur* (ch. 36) ..... *Consideretur semper in eis imbecillitas et ulla tenus eis districtio regulae teneatur in alimentis, sed sit in eis pia consideratio et praeveniant horas canonicas* (ch. 37). The Latin version of Holy Rule of St. Benedict chs. 36, 37 and English translation by Boniface Verheyen accessed on <http://www.osb.org/rb/index.html#English>.

<sup>91</sup>Thomas F. Glick, Steven Livesey and Faith Wallis eds., *Medieval Science, Technology, and Medicine: An Encyclopedia* (New York, 2005), 227-8.

<sup>92</sup>*Frater cui cura domus infirmorum committitur, et infirmis fratribus seruire deputatur, concum suum habeat, et coquinam separatim, si loci situs et facultas talis sit, ut quod infirmis preparari necessarium est, opportuno tempore parari possit.* (*The Monastic Constitutions of Lanfranc*, 132-3).

<sup>93</sup>Medieval Sourcebook: Twelfth Ecumenical Council: Lateran IV 1215, canon 22 accessed on <http://www.fordham.edu/halsall/basis/lateran4.asp>.

<sup>94</sup>Nicholas Orme and Margaret Webster's research on the English Hospital between 1070 and 1570 has found that 68 hospitals were founded between 1080 and 1150; 252 hospitals existed in the second half of the twelfth century; 389 in the first half of the thirteenth century; 496 in the second half of the thirteenth century; 541 in the first half of the fourteenth century; 508 in the second half of the fourteenth century.<sup>94</sup> On the other hand, 179 hospitals were founded between 1144 and the mid-sixteenth century in Scotland. This indicates that if the population of Scotland were a tenth that of England during the period, there were actually more hospitals per capita in Scotland. There are extant documents regarding the foundation of 105 Scottish hospitals. Of these 26 were established in the twelfth century, 33 in the thirteenth, 15 in the fourteenth, 27 in the fifteenth, and 4 in the sixteenth century. The number of inmates a hospital could accommodate varied from two to twenty-two. On average hospitals admitted eight persons (Nicholas Orme and Margaret Webster, *The English Hospital, 1070-1570* (New Haven and London, 1995), 11).

archaeological excavation in 2013 has hinted.<sup>95</sup> The *Miracula* of St Margaret mentions the infirmary:

He [a monk called Roger] was struck with an unexpected weakness from the soles of his feet to the top of his head, his vital heat grew cold, and he fell to the ground, lying there dumb and unconscious. .... they [the brethren] carried him off to the infirmary. He lay there immobile, deprived of all sensation and strength, from the eleventh hour of the day until nocturns (ch. 11).<sup>96</sup>

Apart from the infirmary in the abbey, there were three more hospitals within and around the burgh of Dunfermline. An almshouse at Dunfermline is first referred to in 1327.<sup>97</sup> It was called St Catherine's almshouse and placed outside St Catherine's wynd. It stood out with the complex of the abbey. Therefore, it may have been an independent foundation, not belonging to Dunfermline Abbey. Another almshouse was located just outside the East Port.<sup>98</sup> The third one was the hospital of St Leonard outside Netherton on the road to the Queensferry, which was likely founded by a wife of Alexander III, Queen Margaret, buried at Dunfermline Abbey in 1275, in the second half of the thirteenth century when many other St Leonard's hospitals were founded.<sup>99</sup> The hospital may once have been a leper hospital,<sup>100</sup> perhaps associated with St. Margaret's cure of a boy suffering from leprosy.<sup>101</sup> St Ninian's Chapel, which was marked on the sixteenth-century map of Dunfermline and located between

---

<sup>95</sup> 'Dunfermline Museum and Art Gallery Stie Excavation', *Dunfermline Delivers*, 2 August 2013 accessed on <http://connectingwithyou.co.uk/news/dunfermline-museum-and-art-gallery-site-excavation>.

<sup>96</sup> *Quo facto a planta pedis usque ad uerticem capitis inopinato languore percussus, uitali calore frigescente in terram corruens, mutus iacebat et exanimis. .... per caput et pedes ceteraque membra trahentes ad domum infirmorum usque baiularunt. In qua ab hora quasi undecima diei usque ad nocturnum sensu et robore priuatus iacebat immobilis* (*Miracula*, 96-9).

<sup>97</sup> Cowan and Easson, *Medieval Religious Houses: Scotland*, 164, 167.

<sup>98</sup> Erskine Beveridge ed., *The Burgh Records of Dunfermline* (Edinburgh, 1917), 2, 300, 334, 341; E. P. Dennison and Simon Stronach, *Historic Dunfermline* (Dunfermline, 2007), 25.

<sup>99</sup> Ebenezer Henderson, *The Annals Of Dunfermline And Vicinity: From The Earliest Authentic Period To The Present Time, A.d. 1069-1878* (Glasgow, 1879), 95; Cowan and Easson, *Medieval Religious Houses: Scotland*, 164; E. P. Dennison and Simon Stronach, *Historic Dunfermline*, 25.

<sup>100</sup> *Registrum de Dunfermelyn*, no. 127.

<sup>101</sup> *Miracula*, 116-7.

the High Street and West Queen Anne Street, might also have accommodated lepers.<sup>102</sup> St Thomas also had the ability to cure lepers, which may explain the altar dedicated to St Thomas in Dunfermline Abbey.<sup>103</sup> Due to the contagion of leprosy and the deformity of the body caused by leprosy, lepers were separated from society, sent to the leper house or the leper hospital.<sup>104</sup> Given the separation of lepers, the hospital or the leper house was inevitably placed in a remote area. The location of St Leonard's hospital at Dunfermline and the leper hospital at Harbledown placed outside each town could be explained in this context. The location of hospitals for lepers near London in the Middle Ages also demonstrates the same pattern.<sup>105</sup>

Chapter 24 of St Margaret's *Miracula* mentions a carpenter who undertook trial by hot iron. Although the Chapter does not mention where he came from, it is likely that he was from the burgh or at least the hinterland of Dunfermline. A carpenter, who raped a woman,

carried the iron on the appointed day and experienced a terrible burning. His hand was then sealed, as is customary. The following night at the tomb of the blessed Margaret, he implored her help with as much feeling as he could. .... In the morning he was led to the place where he was to show his hand to the judges.....<sup>106</sup>

His visit to the shrine of St Margaret at night and his attendance for a hearing next morning meant that the place where the hearing was held was close to the abbey. As Bartlett has

---

<sup>102</sup> Beveridge ed., *The Burgh Records of Dunfermline*, xxvii, nos. 267, 270; Dennison and Stronach, *Historic Dunfermline*, 26.

<sup>103</sup> See Plan 3. In the miracle collections of St Thomas, 39 miracles involved the cure of lepers. These relatively frequent occasions of healing lepers might also relate to the leper hospital at Harbledown, just outside of Canterbury (counted from *Material for the History for Thomas Becket*, eds. James Craigie Robertson, vols. I, II; Ward, *Miracles and the Medieval Mind*, 96; Webb, *Pilgrimage in Medieval England*, 49; Peter Richards, *The Medieval Leper and His Northern Heirs* (Woodbridge, 2000), 39).

<sup>104</sup> *Ibid.*, 49; Miri Rubin, *Charity and Community in Medieval Cambridge* (Cambridge, 2002), 115.

<sup>105</sup> Orme and Webster, *The English Hospital, 1070-1570*, 25 and figure 2. Only wealthy communities could afford to support a leper hospital. In exchange for financial support to the leper hospital, the burgh government could demonstrate its ability to serve the community and its capacity for charity (P. H. Cullum, 'Leperhouse and Borough Status in the Thirteenth Century' in P. R. Cross and S. D. Lloyd eds., *Thirteenth Century England III* (Woodbridge, 1991), 37-46).

<sup>106</sup> *Quod ferrum die statuto manu portans, grauissimam sensit miser adustionem, manu siquidem, ut mos est, sigillata, nocte sequenti ad sepulchrum beate Margarite eo quo potuit affectu illius implorauit auxilium. .... Mane autem facto, ad locum ubi manum iudicibus erat ostensurus adducitur.....*(*Miracula*, 118-9).

described, this story suggests several points. Firstly, it is the only known story of trial by ordeal in Medieval Scotland. Secondly, the story demonstrates a judicial authority exercising power to execute the ordeal, which is impressive, given that the date of prohibition for trials by ordeal has been much debated. In Scotland, the law enacted under the reign of Alexander II (1214-49) prohibited the trial by ordeal in cases of theft. Thirdly, St Margaret helped a criminal such as a carpenter who raped a woman, as did the Virgin who responded to all kinds of prayers including even those of sinners.<sup>107</sup>

It is also distinctive that 7% of St Margaret's miracles related to toothache. Two of three miracles relating the cure of toothache (chs. 9, 10, 32) happened to monks of Dunfermline Abbey (chs. 10, 32). In general, monks and clerks, who could reach the shrine easily, were frequently cured of their toothache by the aid of the saint.<sup>108</sup> According to Finucane, one of three types of illnesses is 'chronic but subject to remission', that is, chronic illness whose length of remission depended on the power of a saint rather than psychological, environmental and physiological conditions. The typical example of this group is rheumatoid arthritis.<sup>109</sup> One of St Margaret's miracles cured an illness in remission. A woman called Emma was cured of her toothache, thanks to St Margaret's power. However, she felt that the pain was going to resume: 'the following night when she thought she had been completely restored to health, she still felt inside some of her earlier injury spreading (ch. 9).'<sup>110</sup>

---

<sup>107</sup> *Ibid.*, xlix; Robert Bartlett, *Trial by Fire and Water: The Medieval Judicial Ordeal* (Oxford, 1986), 34-102; Derek A. Rivard, *Blessing the World: Ritual and Lay Piety in Medieval Religion* (Washington, 2009), 237-67. For the act of Alexander II see *Statuta regis Alexandri*, vi. *Acts of the Parliament of Scotland*, i. ed. T. Thomson and C. Innes (Edinburgh, 1844), 70 (400); Hector L. MacQueen, 'Canon Law, Custom and Legislation: Law in the Reign of Alexander II' in Richard Oram ed., *The Reign of Alexander II, 1214-49* (Leiden, 2005), 240. For the Virgin see Ward, *Miracles and the Medieval Mind*, 163-4.

<sup>108</sup> Piere-Andre Sigal, *L'homme et le miracle dans France medievale, XIe-XIIe siecle* (Paris, 1985), 251.

<sup>109</sup> Another type is 'self-limiting', including minor sufferings which got better in time by themselves such as headache, constipation, dyspepsia, repair of broken bone and miraculous extraction of bad teeth. The other is the psychogenic symptoms which caused many pilgrims to suffer from what is recognized as 'conversion hysteria', that is, a mental disorder leading to paralysis and anaesthesia, under the spiritual and emotional circumstance at a shrine (Finucane, *Miracles and Pilgrims*, 79-80).

<sup>110</sup> *Miracula*, 92-5.

The dust of St Margaret's tomb was believed to have holy power for healing afflictions, toothache in particular. For example, as soon as Emma felt the tooth pain, she put the dust from St Margaret's shrine to the tooth (ch. 9).<sup>111</sup> A monk called Reginald, who suffered from toothache, also took 'some of the dust scraped from the tomb' of St Margaret, and 'rubbed it onto his tooth with his finger (ch.10).'<sup>112</sup> Similarly a monk called Lambert 'touched with his finger the stone in which her most holy relics rest, then put the finger in his mouth and rubbed both the front and the back of his teeth with it (ch. 32).'<sup>113</sup> Moreover, the dust was also believed to heal leprosy. A boy suffering from leprosy was healed by drinking the dust brought from the tomb of St Margaret with water (ch. 21).<sup>114</sup>

The tradition of using the holy power of the dust of a shrine to cure infirmities became popular as early as the late sixth century. Gregory of Tours (539-94) noted that the grave of Bishop Cassianus of Autun was damaged by the visitors scratching it to get relic dust.<sup>115</sup> In the same vein, both St Margaret's original tomb and her 1180 tomb were perhaps worn out by pilgrim contact. In the high Middle Ages, this practice grew more widespread. Some miracles of St William of Norwich (c.1132-1144) demonstrate the practice of using holy dust to heal illnesses: a clerk of William the Sheriff, Gaufridus by name, suffering from toothache came to the sepulchre of St William of Norwich, and took dust of the sepulchre and put it on his teeth to rub them; a boy tortured for a year with dysentery was brought to the shrine and drank some dust of the sepulchre mixed with holy water; a father, whose son swallowed a viper, brought his son to St William's tomb, and he took dust from the tomb, mixed it with

---

<sup>111</sup> *Miracula*, 92-5.

<sup>112</sup> *Ibid*, 94-7.

<sup>113</sup> *lapidem in quo sanctissime illius reliquie requiescunt digito tangens, digitum in ore posuit et illo dentes interius exteriusque fricans, omnem quamcicuis mitigavit dolorem (Ibid, 128-9).*

<sup>114</sup> *Ibid*, 116-7.

<sup>115</sup> Gregory of Tours, *Liber in Gloria Confessorum*, 73 in *Monumenta Germaniae Historica, Scriptores Rerum Merovingicarum*, I (Hanover, 1884), 791; John Crook, 'Aspects of Relics Cults' in *The Architectural Setting of the Cult of Saints in the Early Christian West c.300-1200* (Oxford, 2000), 31.

holy water and gave it to his son to drink.<sup>116</sup> Moreover, St Jerome mentioned several instances of kissing sacred relics and tombs,<sup>117</sup> which indicate that kissing/touching relics and shrines was also common practice for the pilgrims seeking to be blessed by holy power. St Margaret's miracles also demonstrate that a pilgrim sought the aid of holy power through contact. The woman called Emma 'kneeled before the tomb, placed her face against the stone as she had been instructed and prayed intently that through her merits and prayers the lady would subdue the pain and restore her to health (ch. 9).'<sup>118</sup>

In addition to curing toothache and leprosy, St Margaret was also involved in healing two blind women: a local woman who had been losing her eyesight for five years (ch.3); and a woman called Avicia who stayed in the burgh of Dunfermline and suffered from weakness of her eyes for a long time (ch. 19).<sup>119</sup> However, St Margaret cured fewer blind people than average. Finucane's research concerning 'miracles reported by lower-class English men and women, and upper class English men in the twelfth and the thirteenth centuries' indicates that 16% of the miracles related to cures of blind women of lower-class; 11% to lower-class blind men; and only 3% upper-class blind men. Lower-class people tended to have more problems with their eyesight than nobles, because malnutrition, in particular vitamin deficiency, might have been common in lower class people. Malnutrition would have been more common in lower class women than lower class men. Moreover, women tended to suffer from hysterical debilities, which could lead to blindness.<sup>120</sup> Given that two recipients who had their eyesight restored through the aid of St Margaret were local women, the pattern of St Margaret's miracles relating to healing of blindness was not such an atypical one, although relatively fewer blind people than average benefited from St Margaret's power.

---

<sup>116</sup> Thomas of Monmouth, *The Life and Miracles of St William of Norwich*, ed. A. Jessopp and M. R. James (Cambridge, 1896), 128, 150, 189-91.

<sup>117</sup> Crook, 'Aspects of Relics Cults', 31-2.

<sup>118</sup> ...., *flectit genua ante sepulchrum, faciem, ut habuit in monitu, apponit lapidi, sollicita preces effundit ut domina meritis suscipiat et precibus, dolore sedato, eam incolumitati restituat* (*Miracula*, 94-5).

<sup>119</sup> *Ibid*, 78-81, 112-5.

<sup>120</sup> Finucane, *Miracles and Pilgrims*, 144-8.



St Margaret's water was believed to have holy power. For example, the woman called Avicia asked to be brought to St Margaret's 'fountain', and she drank some water, put the water on her head and eyes to wash, and went to sleep before St Margaret's altar, which was situated nearby the fountain. When she woke up, her eyesight was restored (ch. 19). This passage indicates that St Margaret's water was believed to have holy power to restore eyesight. The use of water was believed as a healing agent of blindness in the Middle Ages. As Derek A. Rivard points out, along with the Christian formulas in Latin, it is found that vernacular German prayers in the eighth and ninth centuries were used in curing eye diseases, with the aid of a blessing of salts or water as a healing agent.<sup>121</sup> It is not surprising to see blind people restoring their eyesight with the aid of holy water. For example, the *Vita Ædwardi Regis* includes miracle stories about blind men, who were cured by the water with which King Edward the Confessor washed his hands.<sup>122</sup>

Holy water at Dunfermline Abbey was also used to cure other ailments. For example, a woman, who was possessed by a wicked spirit, was brought to St Margaret's fountain (ch. 25). A miller, who swallowed lizards, was led to Dunfermline Abbey and drunk water from the well (ch. 27). A young man, struck by a demon, was also brought to the well of the St Margaret (ch. 30).<sup>123</sup> In fact, it would have been widely accepted that 'holy' wells and 'holy' water had miraculous power. For instance, as Isidore, archbishop of Seville (c.560-636) discussed, several wells were believed to have miraculous strength such as improving memory, making women pregnant or fertile, or increasing people's libido.<sup>124</sup> In the high Middle Ages, holy water in which saints' relics and sacred objects had been diluted or

---

<sup>121</sup> Rivard, *Blessing the World*, 197-8.

<sup>122</sup> 'Likewise a certain blind man was going about claiming..... that if his blind face were washed in the water with which the king rinsed his hands, he would both overcome blindness and restore his lost sight. ....Meanwhile his servants washed the blind man with the same water ..... word was brought to him by his courtiers that he who was blind now saw. [Another blind man had the same experience]: .....when his face had been washed in the same way as the previous blind man, he was restored to health, and the renewed glory of his former condition was given back to him (*The Life of King Edward the Confessor*, ed. Frank Barlow (London, 1962), 62-3, 64).'

<sup>123</sup> *Miracula*, 118-121; 122-3; 126-7.

<sup>124</sup> Rivard, *Blessing the World*, 226-7, n. 31.

immersed seems to have been widely demanded for healing illnesses.<sup>125</sup> For example, Eadmer (c.1060-1126) stated that water with which St Dunstan's possessions had been washed was stored in a jar, and was used in healing.<sup>126</sup> At Reading Abbey, water in which the hand of St James was dipped was also believed to have miraculous powers of healing. A knight called Robert of Stanford suffering from a severe fever came to Reading and drank 'water of blessed James. .... No sooner had he tasted it than it brought about a cure within him.'<sup>127</sup>

As far as the use of water as a healing agent is concerned, above all, the 'water of St Thomas' was considered as one of the most effective and celebrated ways to heal ailments in the twelfth century. St Thomas' water was the blood which remained on the pavement of the cathedral at Canterbury, diluted with water.<sup>128</sup> Although the Book of *Leviticus* in the Old Testament prohibited the consumption of blood, and no preceding hagiographic text mentioned the drinking of a martyr's blood before St Thomas,<sup>129</sup> this practice became a popular way for healing ailments after the martyrdom of St Thomas on 29 December 1170. It was on the very same night that St Thomas was martyred, that the miraculous power of 'St Thomas' water' became apparent. A local man of Canterbury, who witnessed St Thomas' martyrdom, dipped his shirt in the saint's blood. The man returned home and then narrated the murder of St Thomas to his wife afflicted with paralysis. She asked him to wash his

---

<sup>125</sup> Carole Rawcliffe, 'Curing bodies and healing souls: pilgrimage and the sick in medieval East Anglia' in Colin Morris and Peter Roberts eds., *Pilgrimage: The English Experience from Becket to Bunyan* (Cambridge, 2002), 121; Sumption, *Pilgrimage*, 82-3.

<sup>126</sup> Eadmer, *Vita S. Dunstani in Memorials of St Dunstan, Archbishop of Canterbury*, ed. W. Stubbs (Rolls Series 63; London, 1874), 258.

<sup>127</sup> Brian Kemp, 'The Miracles of the Hand of St James', *Berkshire Archaeological Journal*, 65 (1970), 1-19, at 17.

<sup>128</sup> Alyce A. Jordan, 'The "water of Thomas Becket": water as medium, metaphor, and relic' in Cynthia Koss and Anne Scott eds., *The Nature and Function of Water, Baths, Bathing and Hygiene from Antiquity through the Renaissance* (Leiden, 2009), 482; Frank Barlow, *Thomas Becket* (London, 2000), 246-50.

<sup>129</sup> Jordan, 'The "water of Thomas Becket"', 482-4.

blood-stained clothes and mix the blood of the saint in the water; immediately after drinking the blood of the saint diluted with water, she was restored to health.<sup>130</sup>

Thereafter, the story of the water of St Thomas spread rapidly, and the miraculous power of St Thomas' water was believed to heal illnesses. At the tomb of the saint, the monks of Canterbury dispensed water of St Thomas or put wet sponges onto the place, where the blood of the dead saint landed. Then, water of St Thomas was poured into a small container, an ampullae, which became a popular Canterbury pilgrim's souvenir. The pilgrims could purchase an ampullae containing water of St Thomas.<sup>131</sup> In fact, ampullae were initially made for pilgrims who wanted to bring 'Jordan water and other thaumaturgic (miracle working) liquid' from the Holy Land as early as the sixth century.<sup>132</sup> However, in the last three decades of the twelfth-century ampullae became a popular pilgrim's souvenir and a container to carry holy water or oil, due possibly to the impact of St Becket's water.<sup>133</sup> There were various ways and means to obtain the aid of St Thomas. Among them, water of the saint was placed on the top of the list. For example, in Book II, III and IV of William's collection of 161 miracles 45 cases (approximately 28%) occurred after drinking or washing with the water of St Thomas.<sup>134</sup>

Just as St Thomas' blood diluted with water was considered holy water, able to perform miraculous healing, so St Margaret's dust mixed with water from St Margaret's well might have become 'St Margaret's oil' or 'St Margaret's water', which could be carried in an ampullae by pilgrims. It is thus possible that water from 'Margaret's well' itself was sold in ampullae, and the well as a cult focus played a crucial role to make the nave prominent place for the veneration of St Margaret along with St Margaret's tomb, in particular, before 1180,

---

<sup>130</sup> William FitzStephen, *Material for the History for Thomas Becket*, ed. Robertson, vol. iii (London, 1877), 150; Michael Staunton, *The Lives of Thomas Becket* (Manchester, 2001), 205-6.

<sup>131</sup> Sumption, *Pilgrimage*, 83; Jordan, 'The "water of Thomas Becket"', 483.

<sup>132</sup> Brian Spencer, *Pilgrimage Souvenirs and Secular Badges* (Woodbridge, 2010), 3.

<sup>133</sup> *Ibid.*, 38-9.

<sup>134</sup> Kay Brainerd Slocum, *Liturgies in Honour of Thomas Becket* (Toronto, 2003), 83.

as discussed in Chapter Three. If that is the case, a question is raised: is there any possibility that ‘St Margaret’s oil’ or ‘water’ became involved with the rites of royal unction and coronation? In fact, the Scottish crown would have wished to obtain the rites of coronation and unction from the twelfth century, if the purpose of David’s choir to become a place for the royal coronation can be accepted, as discussed in Chapter Three. Full coronation was a rite of the church, permitted to a king from the pope. The new king was anointed by holy oil during the rite of coronation. The act was believed to give the recipient spiritual power and, in consequence, conferred full royal status. In 1221 Alexander II requested permission for coronation, but the pope announced that he should not accept it without the consent of English King Henry III and his counsellors.<sup>135</sup> In the first ten years of Alexander III’s reign, the royal government again attempted to obtain rites of coronation and unction from the pope. By gaining the rites, the crown would have expected to strengthen the kingship.<sup>136</sup>

In the context of attempting to gain these rites, as Alice Taylor argues, the ‘Dunfermline compilation’, which was put together during the reign of Alexander III (1249-86), aimed to demonstrate the Anglo-Saxon ancestry of the Scottish kings in order to convince the pope, who did not want to defy the English king.<sup>137</sup> If Alice Taylor’s argument, along with those of A.A.M. Duncan, Michael Brown and Dauvit Broun, is correct, the monks of Dunfermline Abbey may have tried to gain the rites of coronation and unction for their church instead of Scone Abbey. They would have intended to celebrate the rites at their own abbey at Dunfermline, and expected the abbey’s prosperity as a place for celebrating the rites of coronation and unction as well as royal burial. Unfortunately, however, the attempts during the reign of Alexander III were not successful. It was not until 13 June 1329, six days after

---

<sup>135</sup> *Calendar of Entries in the Papal Registers Relating to Great Britain and Ireland: Papal Letters*, ed. W.H. Bliss and others (London and Dublin, 1893), i, 83; Andrew D.M. Barrell, ‘Scotland and The Papacy in the Reign of Alexander II’ in Oram ed., *The Reign of Alexander II, 1214-49*, 160.

<sup>136</sup> A.A.M. Duncan, *The Kingship of the Scots 842-1292: Succession and Independence* (Edinburgh, 2002), 130-1; Michael Brown, *The Wars of Scotland, 1214-1371* (Edinburgh, 2004), 11; Dauvit Broun, *Scottish Independence and the Idea of Britain From the Picts to Alexander III* (Edinburgh, 2007), 203.

<sup>137</sup> Taylor, ‘Historical writing in twelfth-and thirteenth-century Scotland: the Dunfermline compilation’, 228-52.

the death of King Robert that a papal bull was issued for the Scottish kings to permit the rites of coronation and unction. On 24 November 1331 King David II was crowned and anointed at Scone Abbey.<sup>138</sup> This implies that the plan of Dunfermline monks to host the rites of coronation and unction failed. If the coronation had been held at Dunfermline Abbey, St Margaret's oil might presumably have been used to anoint the new king. Or the oil might have been used at Scone for the coronation, just as the holy oil of St Thomas was used at Westminster for the English king's anointing in the later Middle Ages.<sup>139</sup>

---

<sup>138</sup> Ranald Nicholson, *Scotland: the later Middle Ages* (Edinburgh, 1974), 125.

<sup>139</sup> Binski, *Westminster Abbey and the Plantagenets*, 107, 135.

### **(5) The characteristics of St Margaret's miracles**

St Margaret's miracles, as Bartlett points out, demonstrate the distinctive mark regarding 'the process of the cure': 'incubation, i.e. sleeping at a cult centre prior to healing, and visual apparitions of the saint (and others) are extremely frequent.'<sup>140</sup> Of 45 miracles of St Margaret, 27 cases related to the saint's appearance in vision and involved incubation. Given that only 225 of 2,050 posthumous healing miracles which occurred in French cults during the eleventh and twelfth centuries were associated with the visionary appearance of saints, and that 22 of 161 miracles of William of Canterbury's collection involved St Thomas's appearance in vision, the figure of 60% in St Margaret's case is a very high proportion.<sup>141</sup>

St Margaret's appearance in vision would have encouraged the recipients to undertake pilgrimage to Dunfermline. As Augustine put it, the power of sight might lead a man to comprehend unrealistic beings, shapeless ideas and finally God himself. Thus visual perception led to spiritual progress.<sup>142</sup> Therefore, in medieval times, a vision led people to nourish their faith. It also encouraged the recipients to act: prisoners to escape, sick persons to make pilgrimage and a biographer to write a hagiography of a saint.<sup>143</sup> In particular, St Margaret, who appeared in dreams, commanded the recipients to come to her shrine or specific sites in the church of Dunfermline and to require the saint's intercessory power.<sup>144</sup> Thus, the recipients were encouraged to visit Dunfermline, and in reality, the appearance of St Margaret in vision was one of the crucial catalytic agents to draw pilgrims' attention to Dunfermline.

---

<sup>140</sup> *Miracula*, 1.

<sup>141</sup> *Ibid.*, 1; Sigal, *L'homme et le miracle*, 134, 255. For St Thoms's appearance in vision see Slocum, *Liturgies in Honour of Thomas Becket*, 83.

<sup>142</sup> Carolly Erickson, *The Medieval Vision: Essays in History and Perception* (New York, 1976), 38.

<sup>143</sup> Goodich, 'Vidi in Somnium: The Uses of Dream and Vision in the Miracle' in *Miracles and Wonders*, 100-116.

<sup>144</sup> *Miracula*, chs. 1, 4, 9, 11, 12, 13, 17, 30, 39, 41, 42.

St Margaret's appearance in vision also demonstrates that females were more inclined to seek this kind of miracle than male laity and even monks and priests. Of 27 miracles relating to the saint's appearance in vision, 13 were females, which are 76% of female recipients - 17 individuals - of the saint's miracles. Of 14 lay men, six (43%) had experienced the saint in vision.<sup>145</sup> Lastly, six monks and two priests (61.5%) of 13 monks/priests saw St Margaret's appearance in a vision.<sup>146</sup> The highest proportion of females in the relationship with the saint's appearance in vision may have related to not only their intense prayers and vigils but also females' inclination to be more sensitive and emotional than males.

Pilgrims sought to keep vigil in the shrine of St Margaret. To do so, they should obtain permission: '...she entered the church of Dunfermline and sought permission to spend the night in the church from the guardian of the outer church [who was someone watching over the nave's empty tomb, altars and well in parish church area] (ch. 1).' Permission was also needed for pilgrims to access the innermost part of the shrine: '....., she went to the church and received permission to go into the innermost part of the sanctuary (ch. 9).' A novice also needed permission to go to the shrine: 'I [the prior of the monastery] give you [a novice] permission to go to the tomb at least while the others are sleeping (ch. 34).'<sup>147</sup> To require permission may have related to the flow of pilgrims to and around the shrine. Since an increase in the number of pilgrims to the shrine raised the possibility of troublemaking in a church and damage to the shrine, the shrine was necessary to control the access in order to keep pilgrims quiet and in order, and to protect the shrine, not to disturb the performance of the liturgy. In the same vein, the superstructure of the shrine in the feretory chapel of St Margaret after 1250, which was normally concealed and protected by 'the gilded cover', would have been revealed to the laity on feast days.<sup>148</sup> The *Miracula* of St Margaret recounts

---

<sup>145</sup> *Ibid*, chs. 1, 2, 4, 9, 12, 13, 17, 19, 25, 33, 35, 39, 42; 5, 7, 18, 26, 27, 30.

<sup>146</sup> *Ibid*, chs. 11, 15, 20, 28, 36, 37, 38, 41.

<sup>147</sup> *Ibid*, 74-5, 94-5, 130-1.

<sup>148</sup> Yeoman, 'Saint Margaret's Shrine at Dunfermline Abbey', 84-7; McRoberts and Holmes, *Lost Interiors*, 165.

that 13 men and women were healed of their ailments while keeping vigil at the shrine, on the festival of ‘the reverend virgin and martyr Margaret [St Margaret, Virgin and Martyr feast day 20 July] [*uirginis et martiris Margarite festiuitate*]’ (ch. 8).<sup>149</sup> That so many people could be allowed to keep vigil at the shrine may be explained by the fact that it was on a feast day for a namesake saint.

Sometimes an attempt to isolate the community from the lay visitors led to controlling the access of a shrine. For example, the tomb of St Waltheof of Melrose became difficult to access because of Abbot William’s effort to enforce his desire that Cistercian monasteries should be isolated from crowds visiting them. In the second miracle story of the *Vita Waldevi*, a lay patient was persuaded to request permission for an overnight vigil. In the third miracle, a layman was allowed access to the tomb only after ‘the most urgent request [*obnixius postulato*].’ In the fourth miracle, a patient could gain permission to access the tomb only after ‘repeated and devout petition [*ad crebram denique & devotem ejusdem petitionem*].’ In the seventh miracle, the recipient was granted only ‘by begging, wailing, [and] imploring [*obsecrando, plorando, implorando*].’ According to the chronology of the miracles, after the visit of the seventh miracle recipient Abbot William announced that the patients’ access to St Waltheof’s tomb would be absolutely prohibited.<sup>150</sup>

Some shrines prohibited women’s access, and special permission was required for women who wished to venerate relics. For instance, St Cuthbert, who was reputed as the misogynist after 1083, apparently banned female access to his shrine.<sup>151</sup> In addition, a statute of the Scottish church in the thirteenth century announced that ‘laymen shall not enter the

---

<sup>149</sup> *Miracula*, 88-93.

<sup>150</sup> Birkett, ‘The Struggle for Sanctity’, 47-9; George Joseph McFadden, ‘An Edition and Translation of the Life of Waldef, abbot of Melrose by Jocelin of Furness’ (Columbia University, unpublished PhD thesis, 1952), 182-3, 336; 183; 183-4, 337-8; 185-6, 339; 186, 340.

<sup>151</sup> Finucane, *Miracles and Pilgrims*, 87; Webb, *Pilgrimage in Medieval England*, 82-3; Susan S. Morrison, *Women Pilgrims in Late Medieval England: Private Piety as Public Performance* (New York, 2000), 90-1. For St Cuthbert’s case see William M., Aird, *St Cuthbert and the Normans: The Church of Durham, 1071-1153* (Woodbridge, 1998), 125; J. Raine ed., *Reginaldi monachi Dunelmensis libellus de admirandis beati Cuthberti virtutibus quae novellis patratæ sunt temporibus*, vol. 1 (London, 1835), 152.



choir unless they are knights or barons or founders of churches. And especially women must not enter the choir in time of Mass.<sup>152</sup> This means that the entry of the laity into the choir was limited and should be controlled by the clergy, which corresponds with St Margaret's miracle story indicating a pilgrim 'spent the night in vigils and prayers before the door of the monks' choir'<sup>153</sup>

The collection of St Margaret's miracles seems to strongly intend to draw pilgrims' attention, and in consequence, to encourage the cult of St Margaret. Of St Margaret's miracles in the *Miracula* involving the saint's appearance and incubation, most miracles, with only a few exceptions, happened at specific locations in Dunfermline Abbey church such as at the tomb of the saint (including the earlier tomb), before the door of the monks' choir, or before the altar of St Margaret and St Margaret's fountain (well). A knight, a clerk and a priest experienced the appearance of St Margaret in vision while they slept in their homes (chs. 7, 38, 41). Although a monk saw St Margaret's apparition while he spent a night at an infirmary (ch. 11) and three monks in their own beds (chs. 15, 28, 36),<sup>154</sup> these cases could also be included into the category of miracles occurring at Dunfermline Abbey. In addition, of 18 miracles which did not associate with St Margaret's apparition and incubation,<sup>155</sup> 13 miracles occurred in the abbey. Just two cases occurred outside the abbey, but the recipients also later visited Dunfermline to give thanks and report their cures: a boy, the son of nobleman, was healed of his affliction at home with the aid of St Margaret's dust (ch. 21); a ship carrying grains which had been purchased by the monks of Dunfermline was saved with the aid of St Margaret, when it encountered danger at sea (ch. 40)<sup>156</sup> - a similar miracle happened: while King David's corpse en route to Dunfermline was crossed the sea, it became

---

<sup>152</sup> *Statutes of the Scottish Church 1225- 1559*, ed. David Patrick (Edinburgh, 1907), 48.

<sup>153</sup> *Miracula*, 83.

<sup>154</sup> *Ibid*, 87-9, 135-137, 139-141; 96; 106-107, 122-125, 132-5.

<sup>155</sup> *Ibid*, chs. 3, 6 (three cases), 8 (two cases), 10, 14, 16, 21, 22, 23, 24, 29, 31, 32, 34, 40.

<sup>156</sup> *Ibid*, 116-7, 138-9.

calm. However, when the body left the beach, the waves at sea began to be fierce.<sup>157</sup> Thus, just five of St Margaret's 45 miracles (11%) occurred outside the abbey.<sup>158</sup> The high proportion of miracles occurring in the abbey (89%) might also have encouraged pilgrims to make pilgrimage to Dunfermline, just as the high ratio of appearances of St Margaret in vision. Additionally, since pilgrims were encouraged to go to Dunfermline, the possibility of miracles happening increased. Both suggestions can lead to the conclusion that the cult of St Margaret encouraged pilgrims to undertake pilgrimage to Dunfermline, and that this might be intended by the monks of Dunfermline in order to encourage or sustain the cult of St Margaret.

St Margaret's miracles demonstrate a relatively homogenous and consistent pattern: the high proportion of miracles relating to vision (60%), and occurring in the abbey (89%). A brief comparison might prove helpful here, in order to demonstrate the significance of this more fully. Books II, III and IV of William's collection of St Thomas' miracles include 45 miracles occurring after drinking or washing with the water of St Thomas; 28 cases through invocations; 22 miracles associated with visions; 12 with various vows; 27 with promises of a pilgrimage to Canterbury; and 27 miracles happening at the tomb.<sup>159</sup> In other words, these miracles demonstrate a variety of patterns in terms of the agent performing the miracles. This pattern might be relevant to the influence of the cult of St Thomas, which spread so quickly that it started gaining an international reputation over Europe between 1171 and 1172. Thereafter, the patterns of pilgrims to Canterbury and miracle recipients shifted from the lower-classes and women to male, the nobility and the 'foreigner'.<sup>160</sup> In other words, the cult of St Thomas included a variety of types in terms of geographical patterns of miracles and

---

<sup>157</sup> *CDS*, ii, 116

<sup>158</sup> *Miracula*, chs. 7, 21, 38, 40, 41.

<sup>159</sup> Slocum, *Liturgies in Honour of Thomas Becket*, 83.

<sup>160</sup> Finucane, *Miracles and Pilgrims*, 126; Ward, *Miracles and the Medieval Mind*, 95.

pilgrims, and pilgrims' social status. Several kinds of agents performing miracles show that the cult of St Thomas is also understood in this context.

The high proportion of St Margaret's miracles relating to vision and occurring in the abbey can be discussed further, concerning the strategic purpose of the monks of Dunfermline to secure reliable miracles. As Finucane points out, 'almost half the 3,000-odd English and French posthumous miracles examined in the nine major and the other, minor, cults' were believed to have happened at a patient's home and the other half of miraculous healings were performed at the shrines of saints. As already noted, the miraculous healings were examined by miracle collectors prior to recording them in the collection. In the case of miracles occurring at some places away from the shrine, the collectors had more suspicions of the possibilities of fraud.<sup>161</sup> In particular, it would have been easier to fake the symptoms of blindness and paralysis. Blindness and paralysis were believed to be permanent conditions. However, these symptoms, which were presumably caused by malnutrition, ailments, shock, mental disorder, or traumas, could disappear according to lifestyle changes, whether psychological, environmental or nutritional circumstances.<sup>162</sup> The symptom of blindness and paralysis could increase the possibility of fraud in accounts of miraculous healing of blindness and paralysis. The appearance of saints in vision could also be fabricated with ease, because it was difficult to make a distinction between vision, which 'was usually accepted as a 'real' message from the other world', and dream, which 'was less significant, perhaps - as some medieval writers claimed - only a result of overeating before retiring.'<sup>163</sup> Another reason is that unlike other miracles consisting of visual evidence, a vision cannot be seen or experienced by others.<sup>164</sup> Concerning St Margaret's miracles, the relatively high proportion of miracles involving vision related to a strategic purpose in preparation of a request for St

---

<sup>161</sup> Finucane, *Miracles and Pilgrims*, 69-70.

<sup>162</sup> Koopmans, *Wonderful to Relate*, 37.

<sup>163</sup> Finucane, *Miracles and Pilgrims*, 84-5.

<sup>164</sup> Koopmans, *Wonderful to Relate*, 41.

Margaret's canonisation. In other words, since a vision could not be traced as visual evidence, it was suitable to be exaggerated or even fabricated by miracle collectors. In the same vein, it might be suggested that the high ratio of St Margaret's miracles associated with vision was presumably intended by the monks of Dunfermline to support their request for canonisation of the saint.

This can explain why 89% of St Margaret's recorded miracles occurred in the abbey. As mentioned above, it was known that vision was easier to be faked. Therefore, to meet the requirement of investigation in the canonisation process, in particular, given the stricter standards for candidates in canonisation in the thirteenth century, monks of Dunfermline would have had a number of miracles involving vision verified. The best case avoiding suspicion about the reliability of miracles was presumably to have miracles occur before the crowds in public places. The miracles occurring in the church before many witnesses might have convinced the investigators in the canonisation process to more readily accept the reliability of the miracles. Another possibility is that a high proportion of miracles involved a vision of St Margaret was perhaps influenced by strong and repeated visual imagery in the abbey associated with the saint on altar paintings, wall paintings, seals, ampullae, stained glass, badges etc. The visual imagery from these materials would have become part of a vision of St Margaret in intense prayer or vigil. In addition, a comparison between St Margaret and the Virgin Mary whether intentional or not, or an overlap of the former with the latter, having something in common - their pedagogical role to raise their children spiritually<sup>165</sup> - may have contributed to lead pilgrims to Dunfermline, and the maternal Virgin Mary images which were presumably placed in the church could encourage the pilgrims to see a vision of St Margaret.

---

<sup>165</sup> Huneycutt, 'The Idea of the Perfect Princess: The Life of St Margaret in the Reign of Matilda II (1100-18)', 81-97; Audrey-Beth Fitch, 'Mothers and Their Sons: Mary and Jesus in Scotland, 1450-1560' in Boardman and Williamson eds., *The Cult of Saints and the Virgin Mary in Medieval Scotland*, 159-60.

All the miracles which happened outside the abbey would have been relatively reliable. Only five miracles occurred outside Dunfermline Abbey. Four happened at recipients' homes: a knight, a clerk who was a son of a knight and became a monk of Dunfermline, a priest and a boy, the son of nobleman (chs. 7, 38, 41, 21). A final miracle occurred at sea (ch. 40).<sup>166</sup> Given that the miracles happening at home tended to be less reliable, and that William, a collector of St Thomas Becket's miracles stated that evidence from the nobility could be more trustworthy than that from the poor, because the poor were always liars,<sup>167</sup> it is expected that the recipients who benefited from St Margaret's power at their own home were all high class persons and the clergy, whose testimonies might be more convincing. In addition, since sailors' plight at sea caused by storm was more reliable, the miracle at sea might be obvious evidence. Therefore, these miracles which happened outside the abbey would have been trustworthy to the investigators in the canonisation process, which was presumably part of the strategy of the monks at Dunfermline.

It is also a distinctive characteristic of St Margaret's recorded miracles that the number 'three' appeared frequently, which related to the symbolic meaning from the biblical point of view. The number 'three' or its compounds occurred in eighteen miracles (40%),<sup>168</sup> thirteen of which also involved vision. In particular, in eight cases, the saint's appearance in vision happened on the third night of vigil: 'On the third day before this feast the dumb man spent the night in vigils and prayers before the door of the monks' choir. ....the door of the choir seemed to be opened to him alone.....The renowned lady came out through the door and approached....[*tertia die eandem solemnitate[m] precedente.....*]' (ch. 5); 'On the third night the queen appeared to her in her sleep and said....[*Tercia uero nocte.....*]' (ch. 17); 'After three days and nights had passed, before daybreak in the fourth night, a venerable lady appeared before him.... [*Transactis tribus diebus et noctibus, in quarta nocte ante diluculum*

<sup>166</sup> *Miracula*, 86-9, 134-7, 138-141, 116-7; 138-9.

<sup>167</sup> Robertson ed., *Material for the History for Thomas Becket*, vol. i. 542.

<sup>168</sup> *Miracula*, chs. 5, 6, 7, 15, 16, 17, 18, 20, 23, 25, 26, 27, 29, 30, 34, 35, 36, 42.

*coram....*]' (ch. 18); 'During the third night the clerk, ....., obtained the relief of sleep, during which there appeared to him a queen, venerable in her visage and beautiful in appearance....[*In tertia uero nocte.....*]' (ch. 20); 'On the third night it seemed to the boy that the blessed queen was standing beside him and she told him..... [*Tercia uero nocte.....*]' (ch. 26); 'At first light on the third day the blessed queen appeared to him while he was sleeping and said to him.....[*Cui summo diluculo tercię diei.....*]' (ch. 30); 'On the third night after her arrival at her own house, the queen appeared to her, saying that ....[*Tercia siquidem nocte.....*]' (ch. 35); 'There for three days and nights she lay prostrate in prayer, but around the third hour on the Wednesday....., while ...she was bowing her head in sleep....., blessed Margaret the queen stood by her.....[*...per tres dies et noctes.....circa horam diei terciam.....*] (ch. 42).'<sup>169</sup> Moreover, in St Margaret's miracle story concerning the battle of Largs in 1263, Margaret and her husband, King Malcolm, accompanied by 'three' knights appeared to John Wemyss (ch. 7).<sup>170</sup>

In fact, in the Christian tradition, from its inception, the number 'three' had a symbolic significance. The third day denotes purity. The third day itself should be kept pure and clean: 'the meat of sacrifice must be burned up in the fire on the third day. ...It must be eaten on the day of your sacrifice and on the following day, but what is left over until the third day must be burned up..... (Lev 7:17-18; 19:6-7).' Along with purity, the third day is associated with healing and spiritual activity. Persuading the sinners to return to God, the prophet Hosea used the motif of the third day: 'He has torn us to pieces but he will heal us; He has injured us but he will bind up our wounds. After two days he will revive us; on the third day he will restore us, that we may live in his presence (Hos 6:1-2).' Most importantly, the third day is also associated with the Passion and Resurrection. After Peter's confession, Jesus instructed him

---

<sup>169</sup> *Ibid*, 82-5, 110-111, 111-113, 114-5, 120-123, 126-7, 132-3, 140-145.

<sup>170</sup> *Miracula*, 87-9.

that he ‘must be killed and on the third day be raised to life .....(Matt 16:21; cf. Mark 8:31; Luke 9:22).’ Furthermore, Paul said to the Corinthian Christians:

For what I received I passed on to you as of first importance: that Christ died for our sins according to the Scriptures, that he was buried, that he was raised on the third day according to the Scriptures, and that he appeared to Peter, and then to the twelve (1 Cor 15:3-5).

In this context, the appearance of St Margaret in vision on the third day related to the symbolic meaning of the third day from the biblical point of view. Moreover, given that Dunfermline Abbey was dedicated to the Holy Trinity, that the number ‘three’ and its compounds occurred frequently in the *Miracula* might relate to this spiritual alliance, just as the physical layout of the church presumably did. That is, the abbey church building consisted of three towers, three-side windows in the feretory chapel, three tomb sites for St Margaret, and was adapted for worship of three royal saints, St Margaret, Malcolm III and David I, as discussed in Chapter Three.

Also worthy of note are St Margaret’s miracles for protecting the kingdom. Even though the *Miracula* of St Margaret do not mention it, when King William spent a night at St Margaret’s shrine in 1199, he was persuaded not to attack England by St Margaret.<sup>171</sup> The report of John Barbour (c.1320-1395) demonstrating that St Margaret prophesied of Scot’s retaking of Edinburgh castle during the Wars of Independence, with a painting on St Margaret’s Chapel at the castle.<sup>172</sup> These two cases could promote the cult of St Margaret at the nationwide level and also provide a hint to St Margaret’s position as a protector of the kingdom.

---

<sup>171</sup> *Chronica Magistri Rogeri de Houedene*, ed. W. Stubbs (London, 1868-71), iv. 100; *RRS*, ii, 101.

<sup>172</sup> A.A.M. Duncan ed., *The Bruce - John Barbour* (Edinburgh, 1997), 398-9.

## **(6) Pilgrimage to Dunfermline**

The purposes of pilgrimage to Dunfermline, according to the *Miracula* of St Margaret, can be divided into two groups: pilgrimage for healing and non-healing. As mentioned above, the majority of miracles of the *Miracula* were associated with miraculous healing. Of 45 miracles, a category of non-healing miracle (almost 18%) consists of three moral miracles which happened to monks who intended to abandon their vows, and involved the appearance of St Margaret in vision to a monk (chs. 28, 37; 36);<sup>173</sup> the victory at the battle of Largs in 1263; the restoration of missing finger-mails of a monk; being saved from a fall, burns of the ordeal iron, and the threat of shipwreck (chs. 7, 15, 22, 24, 40).<sup>174</sup> Technically speaking, the monks of Dunfermline receiving St Margaret's power do not belong to the category of pilgrimage to Dunfermline. In addition, the miracle associated with a painter being saved from a fall is not suitable, because the miracle occurred in the dining refectory of the abbey.

The recipients would have visited Dunfermline to inform the monks about their miraculous experiences and to give thanks to God and St Margaret; sailors being saved from a fierce storm (ch. 40) - the towers of Dunfermline Abbey could be seen from the top of the ship's mast in the Forth - would have come to Dunfermline to inform the monks of the miraculous event and to give thanks to God and St Margaret; a boy cured of leprosy at home with the aid of St Margaret (ch. 21); and a clerk being healed his stomach ache at his home (ch. 38). Unlike these miracles, two other miracles, those of a knight and a priest, involved St Margaret's appearance in vision while sleeping in their own homes (chs. 7, 41). After waking up, they visited Dunfermline, following the explicit guidance of the saint, and they were healed of their illnesses at the abbey with the help of St Margaret. As a consequence, these cases might be said to belong to the category of miraculous healing. In sum, in terms of the purposes of pilgrimage to Dunfermline, it might be said that the majority of pilgrims aimed to

---

<sup>173</sup> *Ibid*, 122-5, 134-5, 132-5.

<sup>174</sup> *Ibid*, 86-9, 106-7, 116-7, 118-9, 138-9.



heal their illnesses, and that a few pilgrims visited there to give thanks to God and St Margaret, and implore the help of the saint.

Moreover, there is a recipient of St Margaret's miraculous powers who undertook pilgrimage to the Holy Land. A carpenter suffering from the trial by ordeal visited Dunfermline to implore the aid of the saint. After receiving benefit from the saint, he went to the Holy Land, giving thanks to God and St Margaret (ch. 24). Generally speaking, it was not easy for the people of the Middle Ages, including the Scots, to undertake pilgrimage to distant shrines. In particular, the Holy Land was the longest and most dangerous pilgrim destination. Scottish pilgrims could have their property and family protected until their return under a law dating back to the reign of David I (1124-53). Without a licence from the king, they were not permitted to leave Scotland. To travel through any part of England, the Scots were required to obtain a safe conduct.<sup>175</sup> Scottish pilgrims could travel by boats. Pilgrims, including those of the lower classes without safe-conducts, might have travelled by boats from Scotland to England, in particular, to 'the Sussex, Kent or East-Anglia ports' in order to undertake pilgrimage to Canterbury and other English shrines or for other business.<sup>176</sup> Safe conducts, which took several forms in Medieval Europe, had one feature in common: 'they offered, for a limited time, protection to people on the move who had reason to fear for their safety.' The holder of a safe conduct could be guaranteed safe passage by an armed escort or given an authorized document allowing free passage for the holder. The provider of the safe conduct took responsibility for the safety of the holders and their possessions.<sup>177</sup> For Scottish pilgrims heading for the Holy Land, safe conducts guaranteed often the safety of the holder for two or three years. The longer period of time had sometimes been given. For example, Sir

---

<sup>175</sup> Yeoman, *Pilgrimage in Medieval Scotland*, 110.

<sup>176</sup> Michael Penman, 'The Bruce dynasty, Becket and Scottish pilgrimage to Canterbury, c.1178-c.1404', *Journal of Medieval History*, vol. 32(4) (December, 2006), 363; Webb, *Pilgrimage in Medieval England*, 228.

<sup>177</sup> Karsten Plöger, *England and the Avignon Popes: The Practice of Diplomacy in Late Medieval Europe* (Legenda, 2005), 127.

James Douglas, who was asked to carry the heart of King Robert I (1306-29) to the Holy Land, was given a safe conduct guaranteed for seven years.<sup>178</sup>

Due to the limited number of St Margaret's miracles, the motives of pilgrimage to Dunfermline were likely to be rather simple. Unlike the case of Dunfermline, Diana Webb has found that pilgrims would undertake a pilgrimage in order to serve a penance, heal illnesses, express devotion to a saint, perform vows, receive miracles and obtain an indulgence.<sup>179</sup> She has also categorized the motives in another way: the voluntary pilgrimage and the involuntary. The former was presumably motivated out of pure devotion to a saint, the pilgrims' free will to expiate their sins, the wish for healing their afflictions or resolving other difficulties, or the expression of thanks for the aid of a saint and the pursuit of indulgence.<sup>180</sup> Carrying out a penance might have involved an involuntary pilgrimage. However, a penitence or self-inflicted penance led people to make a pilgrimage voluntarily.<sup>181</sup> Of those motives, the desire to obtain indulgences increased in the high and later Middle Ages. An indulgence, in general, is defined as 'a remission of temporal punishment due to sin' for themselves and for the souls in Purgatory,<sup>182</sup> a place in the next life which, as Jacques Le Goff suggested, first emerged some time between 1170 and 1200.<sup>183</sup> In the Middle Ages, there was a distinction between 'the authority to remit penance through indulgences' and 'the power to remit sins through absolution.' Absolution could be granted by any priest, although absolution for some specific sins could only come from a bishop or

---

<sup>178</sup> Yeoman, *Pilgrimage in Medieval Scotland*, 117, 119. For medieval Scots' pilgrimage abroad see *Ibid*, 110-20; Monsignor David McRoberts, 'Scottish Pilgrims to the Holy Land', *Innes Review*, vol. 20 (spring, 1969), 80-106; Penman, 'The Bruce dynasty, Becket and Scottish pilgrimage to Canterbury, c.1178-c.1404', 346-70.

<sup>179</sup> Webb, *Medieval European Pilgrimage*, 49-69. Finucane has also suggested various reasons for pilgrimage: the pilgrims make a pilgrimage 'to express their piety; demonstrate opposition to kings by honouring their slain enemies; to have a sight-seeing holiday away from the farmyard drudgery; to carry out a penance; to collect free alms and food from monasteries and wealthier travelers, even to rob them; to ask for some such as male heirs, or business success, or overall protection; to be cured of afflictions (Finucane, *Miracles and Pilgrims*, 40).'

<sup>180</sup> Webb, *Pilgrimage in Medieval England*, xv.

<sup>181</sup> Webb, *Medieval European Pilgrimage*, 51.

<sup>182</sup> 'Indulgence' in *The Catholic Encyclopedia* accessed on <http://www.newadvent.org/cathen/07783a.htm>. For theological discussions on indulgences during the Middle Ages see R. N. Swanson, 'Doctrine and development' in *Indulgences in Late Medieval England: Passports to Paradise?* (Cambridge, 2007), 8-22.

<sup>183</sup> Jacques Le Goff, *The Birth of Purgatory*, Arthur Goldhammer trans. (London, 1984), 168.

the pope. Only the pope, cardinal or an archbishop granted indulgences. In terms of issuing indulgences, a bishop was often considered as the pope's delegate or subsidiary authority.<sup>184</sup>

An indulgence deeply related to salvation, the most important thing in Christianity. Thus an indulgence could play a significant role in religious activities, particularly drawing the laity's attention to religious communities where they could secure indulgences. Concerning an indulgence granted to Dunfermline, immediately after the pope declared St Margaret's canonisation on 16 September 1249, on 21 September the pope granted an indulgence of 40 days to penitents who visited Dunfermline Abbey.<sup>185</sup> This indulgence was probably one of the means to cover the expenses of construction, canonisation and translation. On 5 May 1245, Innocent IV commanded the dean and treasurer of Glasgow to give indulgence to the abbot and monks of Dunfermline, so that they should not be brought to Rome for litigation reasons.<sup>186</sup> However, it is not certain how this indulgence affected the laity.

Comparisons and general discussion on indulgence might be helpful here to demonstrate the significance of the indulgence in the promotion of the cult of saints. Indulgences were issued for several reasons.<sup>187</sup> One of these reasons was to encourage devotional and spiritual activities such as attendance at religious services and events. The most important and popular indulgences were given to those who visited religious places on specific dates of the year. Indulgences were also granted to raise funds for certain purposes. In order to raise funds to repair buildings, in 1322 Symon bishop of Galloway granted an indulgence of 40 days to pilgrims, who visited the chapel of St Cuthbert at Durham.<sup>188</sup> In

---

<sup>184</sup> Swanson, *Indulgences in Late Medieval England*, 27-9.

<sup>185</sup> *ESSH*, ii, 87; *Registrum de Dunfermelyn*, no. 290-1.

<sup>186</sup> *Ibid*, nos. 280, 600.

<sup>187</sup> *Ibid*, 46-76.

<sup>188</sup> Yeoman, *Pilgrimage in Medieval Scotland*, 45.

1235 Hugh Northwold, bishop of Ely granted thirty days off purgatory to those who contributed to the construction of the east part of the church at Durham.<sup>189</sup>

Another reason for granting indulgences was to support the maintenance of bridges and roads. Along with the secular authorities and merchants, the ecclesiastical power needed maintenance of roads and bridges to maintain good communications.<sup>190</sup> With regard to pilgrimage, apart from the dangers to life and health, the conditions of the road made it difficult to go to religious sites. Therefore, the maintenance of roads was essential to promote people to make pilgrimages. Since the maintenance of roads was considered a charitable action equal to alms giving, the road used, in particular, by the pilgrims was often repaired by volunteers.<sup>191</sup> In addition, to keep a bridge safely or build a stone bridge, or establish a ferry was also important, because it was closely related to the safety of people who crossed the river. The accident of twenty high-ranking monks and clerics, who were drowned at the River Eden, St Andrews, in the first quarter of the fifteenth century while crossing, demonstrates the necessity of the bridge. This accident led to the construction of the stone bridge at Guardbridge in 1419.<sup>192</sup> In the same context, in 1441 a papal indulgence was granted to Margaret, countess of Galloway, who supported the building of a stone bridge at the River Bladnoch, which was primarily used by pilgrims on their way to St Ninian's shrine at Whithorn.<sup>193</sup> Although it was not an indulgence, there is evidence indicating that Dunfermline Abbey also had a responsibility to maintain roads and bridges. David I issued a charter allowing the church to be free from all customary service on castles, bridges and other

---

<sup>189</sup> *Rites of Durham: Being A Description Or Brief Declaration of All the Ancient Monuments, Rites and Customs belonging or being within the monastical church of Durham before the suppression. Written, 1593*, ed. J.T. Fowler (Durham, 1903), 150; Peter Draper, 'The Nine Altars at Durham and Fountains' in *Medieval Art and Architecture at Durham Cathedral: The British Archaeological Association Conference Transactions for the year 1977* (1980), 74.

<sup>190</sup> Norbert Ohler, *The Medieval Traveller* (Woodbridge, 1998), 22.

<sup>191</sup> Sumption, *Pilgrimage*, 176. For the poor condition of Medieval roads see Diana's description on of it (Webb, *Pilgrimage in Medieval England*, 222-3).

<sup>192</sup> Yeoman, *Pilgrimage in Medieval Scotland*, 58.

<sup>193</sup> R. C. Reid ed., *Wigtonshire Charters* (Edinburgh, 1960), 119.

works between 1128 and 1136<sup>194</sup> to help the church concentrate on its own construction scheme. Malcolm IV also granted that Dunfermline Abbey ‘shall be free of labour-service on bridges, castles and everything else’ between 1161 and 1164.<sup>195</sup> As the charters indicated, Dunfermline Abbey would have maintained roads and bridges unless they were freed from the duty. In particular, the Queensferry itself and the road from Queensferry to Dunfermline, and a bridge which made it possible to access the town from the west, were presumably maintained by contributions from the abbey.<sup>196</sup> Concerning the maintenance of the road and bridge at Dunfermline, the burgh government may also have taken a responsibility for keeping the traffic network, given its status as a royal burgh and a market town. The grants Alexander II gave the abbey of the forest of Dollar in 1236 and some land at Dollar in 1237<sup>197</sup> indicate that these were perhaps chosen to give the abbey somewhere along pilgrim routes toward Dunfermline from the west or to offer valuable building resources, assuming there were trees in the forest.

With regard to the length of time of indulgences, only the pope could grant ‘the crusade indulgence’, ‘the plenary remission of sins’ and ‘the Jubilee indulgence’ - the papal Jubilee, which had originally been a Jewish tradition, was not instituted by the church until 1300. Before then, this term was often used to inspire the Crusaders by Bernard of Clairvaux (1090-1153).<sup>198</sup> Only the pope could grant more than 100 days’ indulgence and often the remission

---

<sup>194</sup> *Registrum de Dunfermelyn*, no. 31.

<sup>195</sup> *Ibid.*, 49.

<sup>196</sup> A new bridge was founded in 1767 at Dunfermline (Dennison and Stronach, *Historic Dunfermline*, 42).

<sup>197</sup> *Registrum de Dunfermelyn*, nos. 75-6

<sup>198</sup> Sumption, *Pilgrimage*, 231. In February 1300 Pope Boniface VIII realized that pilgrims coming to Rome expected to obtain something special at the beginning of the new century. He announced the first Holy year or Jubilee, and he granted Jubilee indulgence to all those who visited the church of the apostles: ‘Bishop Boniface, servant of the servants of God, in perpetual memory of this matter....., to those going to the famous church of the Prince of the Apostles in the City, great remissions and indulgences of their sins have been granted.’ The requirement to gain Jubilee indulgence was different between Romans and ‘foreigners’: ‘.....if they are Romans, they shall go to those churches on at least thirty days, consecutively, or at intervals, and at least once in the day; but, if they be pilgrims or foreigners, they shall in like manner go on fifteen days.’ He also mentioned that the Jubilee would take place in every hundredth year: ‘....and in every hundredth year to come, shall reverently go to those churches, having truly repented and confessed, or being about to truly repent and confess (The Institution of the Jubilee, 1300, “Bullarium Romanum ed. Taurinensis vol. iv, 156-7” translated in *Select Historical*

of one year and one Lent. Apart from the pope's monopoly of the right to grant indulgences of longer periods of time which lasted until at least the early sixteenth century, the fourth Lateran council announced that any other indulgence granted no more than 40 days with the exception of an indulgence of one year on the occasion of a church's dedication. The only regular exception from the late fourteenth century was allowed when cardinals granted indulgences of up to 100 days. In England, in general 40 days off purgatory from an individual grantee was the maximum until the fifteenth century when English prelates became cardinals and they could grant up to 100 days.<sup>199</sup>

Apart from Rome's Jubilee, on 7 July 1220 St. Thomas' first Jubilee, 50 years after his martyrdom and translation festival, proved to be a crucial turning point in terms of the shift of the concept of the Jubilee from that of Jewish to a more Christian one.<sup>200</sup> Becket's Jubilee would have taken place every fifty years in 1370, 1420 and 1470.<sup>201</sup> Offerings from the pilgrims show an increase in the years of a Jubilee. From the fact that the obligations in the years of 1269/70 and 1319/20 did not increase,<sup>202</sup> it might be suggested that a Becket Jubilee with indulgences was probably not held in 1270 and 1320. That is, it is probably that

---

*Document of the Middle Ages*, trans. and ed. Ernest F. Henderson (London, 1903), 349-50). However, in 1343 Clement VI, who resided at Avignon, proclaimed that the Jubilee would take place every fifty years. In 1350 a Jubilee was held. Alexander Bur, abbot of Dunfermline, who had been appointed as abbot in 1328-9, died in Lombardy in 1350 or early 1351 on his way back to Scotland from the Jubilee celebrations at Rome. Then Urban VI (1378-89) reduced the period to every thirty years, which corresponded to the life-span of Christ. The pope announced that the Jubilee would be held in 1390. In 1400 such a large number of pilgrims came to Rome that Boniface IX granted them indulgence. Later the interval of Jubilee reverted again to a period of fifty years, and a Jubilee was held in 1450. Paul II declared that the Jubilee would be celebrated every twenty-five years. A Jubilee took place in 1475. Since then, this has been the general rule (Webb, *Medieval European Pilgrimage*, 26-7. For Alexander Bur abbot of Dunfermline see *Chron. Bower*, vii, 277; *Registrum de Dunfermelyn*, xiv).

<sup>199</sup> Medieval Sourcebook: Twelfth Ecumenical Council: Lateran IV 1215, canon 62 accessed on <http://www.fordham.edu/halsall/basis/lateran4.asp>; Swanson, *Indulgences in Late Medieval England*, 30-2.

<sup>200</sup> Pope Honorius III (1216-1227) granted an indulgence of 40 days to all who came to Canterbury on the day of translation of St Thomas or within 15 days thereafter. The present Legate granted 40 days, the three archbishops also granted 40 days and the seventeen bishops granted 20 days (Anne F. Harris, 'Pilgrimage, Performance, and Stained Glass at Canterbury Cathedral' in Sarah Blick and Rita Tekippe eds., *Art and Architecture of Late Medieval Pilgrimage in Northern Europe and The British Isles Texts* (Leiden, 2004), 274-9. For the indulgences at Becket's Jubilee see W. Stubbs, *Memoriale Fratris Walteri de Conventria* (London, 1873), II, 246; R. Foreville, *Le Jubilé de saint Thomas Becket du XIIIe au XVe siècle (1220-1470): étude et documents* (Paris, 1958)). In total, 540 days indulgence was granted to pilgrims who visited Canterbury on the date of St Thomas's translation.

<sup>201</sup> Sumption, *Pilgrimage*, 150.

<sup>202</sup> Ben Nilson, *Cathedral Shrines of Medieval England* (Woodbridge, 2001), 211-5.

although a 100th and a 150th anniversaries of St Thomas's martyrdom were celebrated, pilgrims did not come to Canterbury in greater numbers because no indulgence was granted.

With regard to Dunfermline Abbey, there is no extant document indicating that St Margaret's Jubilee took place and indulgences were granted to all who came to Dunfermline on the day of St Margaret's Jubilee. However, St Margaret's Jubilee could have been celebrated, although indulgences were not granted. Some evidence allows us to speculate about the celebration of anniversaries. On 12 August 1293 King John confirmed a grant, which had been given by King William, to Dunfermline of 100s. annually from the fermes of Edinburgh. It is possible that this confirmation associated with the 200<sup>th</sup> anniversary of Margaret's death (16 November 1093), although no extant place-dates of Balliol's royal acts identified it.<sup>203</sup> In 1300 William de Lamberton, bishop of St Andrews extolled the sanctity of Dunfermline Abbey, giving the abbey 'the vicarage of a church to render the monk of abbey still more fervent.'<sup>204</sup> From this fact, it is possible to draw the deduction that in 1300/1 the 50<sup>th</sup> anniversary of St Margaret's translation and the 150<sup>th</sup> of abbey's dedication were probably celebrated, even if it was not splendidly marked in wartime. In addition, the residence of David II at Dunfermline on 17 September 1343,<sup>205</sup> and a grant of £8 to the chaplain of St Margaret in Edinburgh castle paid in 1393,<sup>206</sup> might be relevant to the 250<sup>th</sup> and the 300<sup>th</sup> anniversary of St Margaret's death respectively.

Whether pilgrims undertook pilgrimage to secure indulgences or other reasons, pilgrims were entitled to free accommodation and food from the early Church. In western Christianity, the tradition was upheld by the Benedictine rule:

---

<sup>203</sup> *Handlist*, ii, no. 403 John also granted to other religious foundations such as the monastery of St Mary's Lindores in Fife (*Ibid*, no. 404); Friars Minors of Dundee (no. 369); Friars Preachers of Linlithgow (no. 379). According to place-dates of Balliol royal acts, Balliol was present at Stirling on 10 August 1293; at Edinburgh 12 August; at Buittle on 13 January (*Ibid*, nos. 367, 368; Amanda Beam, *The Balliol Dynasty 1210-1364* (Edinburgh, 2008), 301).

<sup>204</sup> *Registrum de Dunfermelyn*, no. 122.

<sup>205</sup> *RRS*, vi, no. 75.

<sup>206</sup> *ER*, iii, 321.

..... let him [a guest] be met by the Superior and the brethren with every mark of charity. ....Let the greatest care be taken, especially in the reception of the poor and travellers, because Christ is received more specially in them.....(chapter 53).<sup>207</sup>

Since then, the increase of monasteries' interest in hospitality was observed, even though the rule was varyingly obeyed by individual monasteries. As for monasteries situated en route to popular religious places, they themselves could not accommodate a high number of pilgrims. Therefore, pilgrims' guest halls were founded to provide hospitality to guests. Later on, to accommodate pilgrims, small hospices run by a small group of monks or canons were founded away from the monasteries.<sup>208</sup>

On the pilgrims' routes in medieval Scotland, pilgrims' accommodation such as hospices were established. For example, St Andrews was a popular pilgrimage site in medieval Scotland. There were four major routes to get to St Andrews, crossing the Tay from the North or the Forth from the south, or coming from the east by sea or from the landed west. Of these routes, the most famous way was via the Queen's Ferry. Queen Margaret founded a ferry crossing at the Firth of Forth for pilgrims heading for St Andrews from Edinburgh and the south-west. Queen Margaret provided pilgrims with free shipping to carry them across, and also built hostels on either side of the sea so that pilgrims could rest there with great care provided by attendants who were appointed by the queen.<sup>209</sup> In the miracle stories of St Margaret, a woman is mentioned as arriving at the hospital after crossing the sea at Queensferry (ch. 29). The hospital mentioned in this miracle might have been the hostel having been established by St Margaret. In the mid-twelfth century another ferry called

---

<sup>207</sup> ..... *occurratur ei a priore vel a fratribus cum omni officio caritatis, ..... Pauperum et peregrinorum maxime susceptioni cura sollicite exhibeatur, quia in ipsis magis Christus suscipitur*....(ch. 53) accessed on <http://www.osb.org/rb/index.html>.

<sup>208</sup> Sumption, *Pilgrimage*, 198-201.

<sup>209</sup> Turgot, *Life of St. Margaret, Queen of Scotland*, 59-60; *ESSH*, ii, 77.



Earlsferry was founded at the eastern part of the Forth, ‘between North Berwick and Ardross in Fife’ to carry pilgrims going to St Andrews, by an earl Duncan of Fife. The earl also built a pilgrims’ hospice at North Berwick, which was run by Cistercian nuns.<sup>210</sup> When the pilgrims arrived at St Andrews, they needed to find accommodation. Only the poor and weak pilgrims might have found their accommodation at a hostel or a hospital. Others might have stayed at inns or elsewhere. In Queen Margaret’s time, a main pilgrims’ hostel might have been placed to the south-west of Kinrymout, 200m away from the early cathedral. Six pilgrims could stay in the hospital in King Alexander I’s time (1107-24). The hospital’s church raised its status as the parish church of St Leonard by around 1200.<sup>211</sup>

Near Dunfermline was the most famous confluence of routes for pilgrims heading for St Andrews, which was a popular pilgrimage place possessing of relics of St Andrew, St Serf’s monastery at Loch Leven, Culross Abbey, Dunkeld Cathedral holding relics of St Columba,<sup>212</sup> alongside the route for Queensferry and the road en route to Stirling. In particular, pilgrimage routes nearby Dunfermline would have been full of pilgrims before and after Mid-Summer - the feast day of David I (24 May)<sup>213</sup> and the translation feast day of St Margaret (19 June) at Dunfermline; the feast day of St Serf (1 July) at Loch Leven; the translation feast of St Thomas Becket (7 July) at Arbroath - which was a good season to travel because the weather was fair and the harvest had not yet come. Therefore, Dunfermline would have been required to provide accommodation for pilgrims and travellers. As mentioned above, there were hospitals and almshouses within and around the burgh of Dunfermline along with the infirmary of the abbey: St Catherine’s almshouse; the almshouse just outside East Port; the hospital of St Leonard. Poor pilgrims might have been

---

<sup>210</sup> Yeoman, *Pilgrimage in Medieval Scotland*, 55-9; Stewart Cruden, *Scottish Medieval Churches* (Edinburgh, 1986), 17-9. For St Margaret’s miracle see *Miracula*, 124-7.

<sup>211</sup> Yeoman, *Pilgrimage in Medieval Scotland*, 55.

<sup>212</sup> *Ibid*, 16, 85-9; Mackinlay, *Ancient Church Dedication in Scotland*, 485, 40.

<sup>213</sup> *Butler’s Lives of the Saints*, eds. Herbert Thurston and Donald Attwater (Texas, 1956), 383-4.

accommodated at the first two almshouses. The hospital of St Leonard seems to have been once used as a leper-hospital/house.

Map 1. Pilgrimage routes around Dunfermline

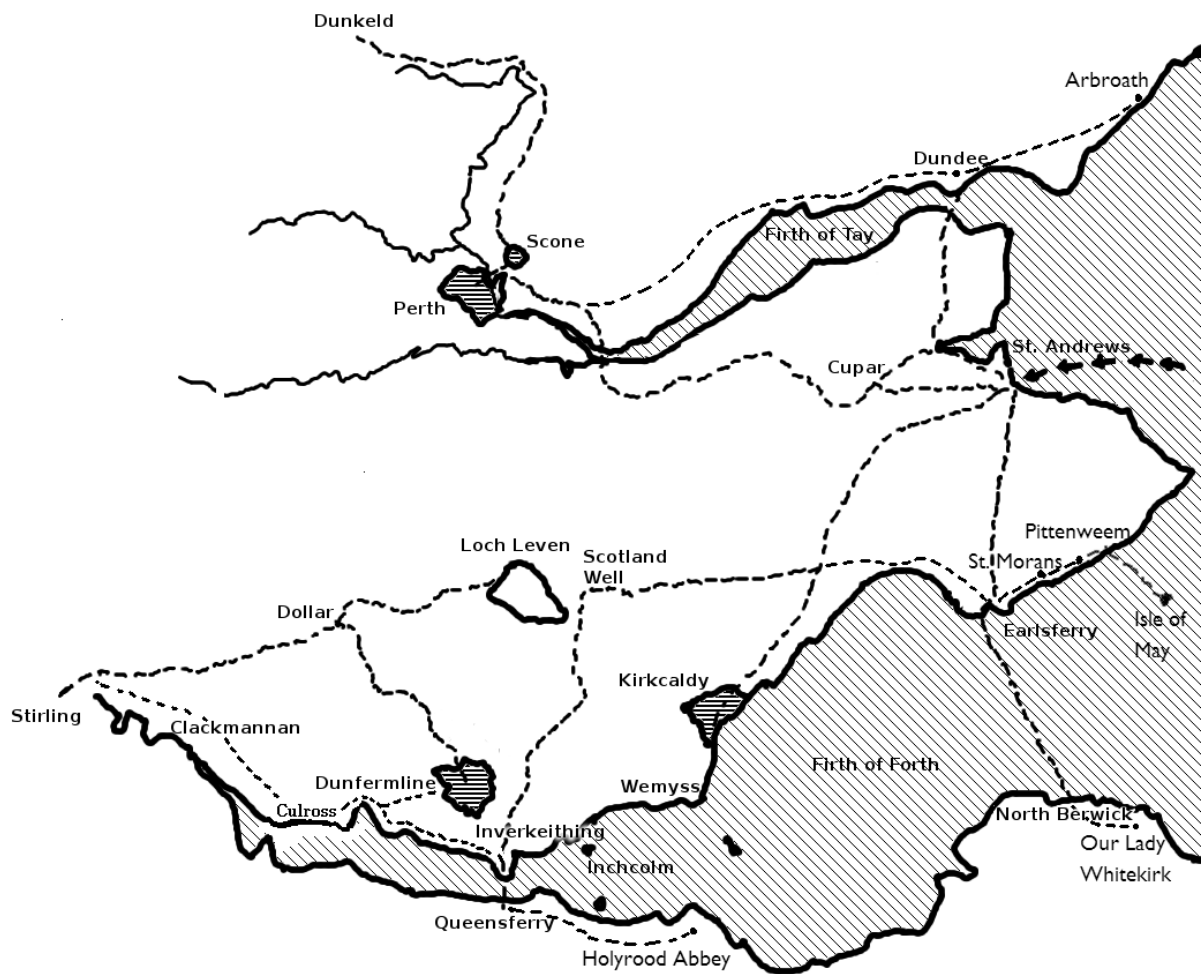

Since pilgrimage to religious sites required expenses, a poor pilgrim who could not afford it hoped for free hospitality and alms.<sup>214</sup> In the *Miracula* some poor pilgrims made pilgrimage to several places over a long period of time: a poor little woman who lived in eastern England and went to France (ch. 1); a man ‘wandered through many lands, visiting the monasteries of various saints..... (ch. 5)’; a woman ‘travelled around the whole of England for seven years visiting the shrines of the saints... (ch. 39).’<sup>215</sup> These stories indicate that St Margaret prevailed over other saints in terms of cult competition, and make one wonder how these visitors could afford the expense of such a long journey. The following miracle story provides a clue to answer the question: a woman who ‘lay there [outside the gateway of the monks serving God and St Margaret] naked and wretched for half a year, receiving the general alms by which she, along with the other poor people, was fed each day (ch. 3).’<sup>216</sup> That is, when the poor arrived at Dunfermline, they could be granted alms. The granting of alms to the poor at Dunfermline would have been conducted by Lanfranc’s

*Constitutions:*

the almoner, either himself if occasion serve, or by means of reliable and truthful servants, shall take pains to cover where may lie those sick and weakly persons who are without means of sustenance. .... Entering a house [of the indigent] he shall speak kindly and comfort the sick man, and offer him the best of what he has that may be needful for him. If the sick man asks for something else he shall do what he can to obtain it.

---

<sup>214</sup> For the cost of pilgrimage see Sumption, *Pilgrimage*, 203-10.

<sup>215</sup> *Galliarum partes ingrediens, ubi quoscumque martires seu confessores uel sacras virgines in Christo magna operantes audierat, eorum intrat ecclesias.....(ch.1); Terras plurimas perambulando, monasteria diversorum sanctorum visitando..... (ch. 5); Ydropica quedam totam Angliam, loca sanctorum visitando, per septem annos circuiuit....(ch. 39) (Miracula, 69-75, 82-5, 136-9).*

<sup>216</sup> *...per dimidium annum in nudo miserabiliter iacentem et communem elemoniam accipientem, qua ipsa cum ceteris pauperibus per singulos dies pascebatur (Ibid, 79-81).* Several royal charters to Dunfermline Abbey also demonstrate that the Scottish kings gave the abbey grants as ‘perpetual and free alms’ (*Registrum de Dunfermelyn*, nos. 3, 5, 7, 12, 26, 28, 30 (during the reign of David I), 36, 37, 38, 39, 40, 41, 44, 46, 47 (Malcolm IV), 53, 55, 58, 60, 61, 64, 66, 69, 73 (William), 345,360, 361, 363 (Robert I); *The Charters of David I*, nos. 19, 21, 99, 137, 140, 141, 171; *RRS*, i, nos. 112, 117, 157, 164, 165, 178, 182, 214, 229; *RRS*, ii, 22, 107, 164, 242, 321, 337, 396, 409, 502; *RRS*, v, 190, 206, 406, 443).

The almoner had visited the poor and the sick to grant alms in Lanfranc's time. However, as the time passed, alms were instead offered at the gateway or in the almonry.<sup>217</sup>

Having arrived at shrines, pilgrims purchased souvenirs such as pilgrim badges, medallions, pendants and ampullae. Badges, pendants and medallions may simply have been touched sacred places or relics.<sup>218</sup> The images on pilgrims' badges or ampullae deeply represented saints to whom shrines were dedicated. Since no example demonstrating the images of Dunfermline ampullae and badges has been found in excavations, other cases might be helpful here, in order to speculate those of Dunfermline. Canterbury ampullae depicted 'Thomas travelling by ship'. The ship ampullae often included the illustration of Thomas' martyrdom, the Crucifixion or an image of his shrine. Other images on Canterbury ampullae involved the visual connection between St Thomas and Christ: some ampullae were placed in the shape of a rose window, which was a characteristic of Gothic architecture and filled with images of Christian themes; others put the container within a circular pattern, which looked like 'Christ's cruciform halo'.<sup>219</sup> Ampullae of York Minster show the figures of St William of Beverley in the centre, St Peter and St Paul on either side, three dedicative saints all deeply involved with York Minster. Another image of York Minster ampullae consisted of a cross probably representing the host in this case, and a chalice perhaps symbolizing the blood of Christ. This image might be relevant to the late medieval cult of *Corpus Christi* in York, celebrating the devotion of the 'consecrated host and the body of

---

<sup>217</sup> *Elemosinarius aut per se, si opportunum sibi est, perquirat, aut per ueraces et fideles homines cum multa sollicitudine perquiri faciat, ubi egri, et debiles iaceant, qui non habent unde se sustentare ualeant. .... Ingressus domum blande consoletur egrum, et offerat ei quod melius habet, et sibi intelligit esse necessarium. Quod si eger aliud requirit, et ipsum perquirat, si aliquot modo habere potuerit* (*The Monastic Constitutions of Lanfranc*, 132-3, n. 334).

<sup>218</sup> Katja Boertjes, 'Pilgrim Ampullae of York Minster and the Healing Oil from the Shrine of St William' in Sarah Blick ed., *Beyond Pilgrim Souvenirs And Secular Badges: Essays in Honour of Brian Spencer* (Oxford, 2007), 57.

<sup>219</sup> Jordan, 'The "water of Thomas Becket"', 489-92. For a shape of Canterbury ampullae see Boertjes, 'Pilgrim Ampullae of York Minster and the Healing Oil from the Shrine of St William', 53-8.

Christ'.<sup>220</sup> In Scotland, a later medieval Whithorn badge is likely to depict St Ninian. A badge from Melrose Abbey demonstrates the place-name (Melrose) spelling out 'a mason's hammer (mel) and a rose (ros)'. A fifteenth-century badge found at East Castle, Berwickshire, depicts the Assumption of the Virgin, and a source of the discovered badge was possibly the shrine of Our Lady at Whitekirk. Pilgrims' badges of St Andrews and moulds for casting them from the thirteenth to fifteenth century, which were found in Perth, London, North Berwick and Kinross, all depict St Andrews.<sup>221</sup>

In the same context, Dunfermline ampullae and badges might have depicted St Margaret. In particular, the existence of the female figure, who was probably St Margaret herself, on the Chapter seal of Dunfermline Abbey in the later thirteenth century<sup>222</sup> suggests the likelihood that St Margaret was depicted on Dunfermline ampullae and badges in an image similar to the Virgin. In addition, in the Middle Ages many pregnant women wore ampullae containing holy water or holy oil, or pilgrim's badges illustrating 'the Virgin and Child, the Annunciation or the Holy House of Walsingham (a wooden replica of the dwelling in Nazareth where medieval men and women believed the Incarnation had begun).'<sup>223</sup> Given the involvement of St Margaret's 'sark' in childbirth, as discussed in Chapter Two, and the life of St Margaret as a good mother, the Virgin was also possibly depicted on Dunfermline souvenirs. Or, as St Margaret's miracle story concerning the battle of Largs in 1263 described (ch. 7),<sup>224</sup> St Margaret and her husband, King Malcolm III, and her three sons - Edgar, Alexander I and David - who were buried at Dunfermline, could be depicted on the souvenirs.

It is unknown where pilgrims' souvenirs of Dunfermline were sold. However, some evidence of other communities can inform speculation. Certain families running businesses

---

<sup>220</sup> St William of York was Archbishop of York and buried at York (d. 8 June 1154). The two apostles have been worshipped in York Minster since the eighth century (*Ibid*, 53, 56).

<sup>221</sup> Yeoman, *Pilgrimage in Medieval Scotland*, 46-8, 60-1.

<sup>222</sup> Henderson, *The Annals Of Dunfermline And Vicinity*, 70-1.

<sup>223</sup> Rawcliffe, 'Curing bodies and healing souls: pilgrimage and the sick in medieval East Anglia', 136.

<sup>224</sup> *Miracula*, 89.

for manufacturing other metal goods and religious houses were permitted the privilege of making and selling souvenirs.<sup>225</sup> The house of Cistercian nuns at North Berwick, at which pilgrims embarked by boat to cross the Firth of Forth, sold pilgrims' badges of St Andrews and others. The house could also have produced the badges, because a cast for these badges dated to the thirteenth or fourteenth century was discovered during a nineteenth-century excavation of the house. Given the geographical proximity of Dunfermline to North Berwick, it is likely that pilgrim's souvenirs of Dunfermline were also sold by the nuns at North Berwick.

Dunfermline Abbey contributed to the development of the local economy, and *vice versa*, with the grant of market on specific day: in 1305 English King Edward granted Dunfermline Abbey 'a weekly market held on Thursday at his manor of Kirkcaldy in the county of Fife, and a yearly fair on Saturday in Easter week and two following days.'<sup>226</sup> Dunfermline Abbey might also have been granted a fair on a special occasion. The miracle stories suggest that a fair would have occurred on the translation feast of St Margaret (19 June): 'a merchant came to the feast of the translation of St Margaret, as is the custom of merchants, in order to sell (ch. 23).'<sup>227</sup> The feast day of St Margaret's translation is on 19 June, just before Mid-Summer. In addition, the feast day split the year in two alongside the date of St Margaret's death on 16 November. In this vein, the date of the translation was probably determined by a deliberate strategic choice of the monks. These patterns are found in other shrines. For example, on 7 July 1383, at the festival of St Thomas' translation, Richard II granted a fair to Canterbury Cathedral. In general, this kind of trade fair lasted for seven days. On the translation feast day of St Etheldread at Canterbury a fair opened for three days before and after. For five days before the festival of St Augustine's translation and two days after, a fair occurred at Canterbury. The fair to celebrate the arrival of the Holy Blood at

---

<sup>225</sup> Finucane, *Miracles and Pilgrims*, 42; Webb, *Medieval European Pilgrimage*, 35-6.

<sup>226</sup> *CDS*, ii, no. 1653.

<sup>227</sup> *Miracula*, 116-9.

Westminster Abbey in 1248 was the most noteworthy. Henry III granted a fair lasting for a fortnight and prohibited all other markets during that time.<sup>228</sup>

---

<sup>228</sup> Nilson, *Cathedral Shrines of Medieval England* , 92-3.

## **(7) Conclusion**

Miracles were sometimes exaggerated to show off the power of a saint. The miracles of St Margaret were also exaggerated in some key points. For example, the *Miracula* accounted St Margaret's prediction of the victory at the so-called battle of Largs in 1263 through her appearance in vision to a knight, John of Wemyss, the achievement of the miracle, and the healing of the knight's illness. On the other hand, the *Chronicle* of Fordun (before 1360-c.1384) mentioned just the victory of the battle.<sup>229</sup> Later on, Bower (1385-1449), who had consulted Fordun's chronicle, stated both the victory of the battle and the appearance of St Margaret in vision to the knight. As the *Scotichronicon* editorial team assessed, Bower presumably brought the knight's miracle story from Dunfermline Abbey material.<sup>230</sup> The manuscript version of Bower concerning the miracle seems to have put a value on the knight's experience in seeing the saint in vision and hearing her prediction, and curing his illness. On the other hand, the *Miracula* appears to have emphasised that St Margaret precipitated a fierce storm in order to protect Scotland from the Norwegian invasion, and before performing this miracle the saint appeared in an apparition to the knight. These differences might be derived from the attempt of monks of Dunfermline, who wished to promote the cult of St Margaret at a nationwide level and, in consequence, to develop or sustain the cult.

As Bartlett has termed the year 1170, the year of St Becket's martyrdom, as 'the 1066 of English saintly cult',<sup>231</sup> in the last third of the twelfth century many miracle collections of several saints were written: collections for Godric at Finchale (compiled after 1172), for Germanus at Selby (finished in 1174), for Bartholomew in London (written between 1174 and 1189), for William of York (c.1177), for the cross of Waltham (after 1177), and for

---

<sup>229</sup> Johannis de Fordun, *Chronica Gentis Scotorum*, ed. W.F. Skene (Edinburgh, 1871) [hereafter, *Chron.Fordun*], i, 299-300.

<sup>230</sup> *Chron. Bower*, v. 337, 339, 341, 460-1.

<sup>231</sup> Bartlett, 'The Hagiography of Angevin England', 40.



Frideswide at Oxford (after 1180). Another collection written probably during this period is ‘William de Vere’s (now lost) collection for Osith, at Chich (Essex), and possibly, too, Jocelin of Brakelond’s collection of the miracles of Robert of Bury (d.1181), also lost.’<sup>232</sup> In addition, given a number of St Thomas collections including ‘ten *vitae*, a massive letter collection, and dozens of hymns and liturgies’ in the fifteen years after Becket’s death,<sup>233</sup> this was the peak of production of English miracle collections. One of the greatest events in collecting English miracles was St Thomas’ translation in 1220. The event boosted the enthusiasm for collection of miracles, along with the construction of feretory shrines and multiple tomb stations. However, in spite of the passion for collecting miracles, momentum was lost in the first two decades of the thirteenth century, and just a few new collections such as those for Simon de Montfort, Thomas Cantilupe and Henry VI were written after 1220.<sup>234</sup> This trend might relate to the strictness of the canonisation process from the thirteenth century onwards, and miracles becoming less valuable in that process from the last third of the thirteenth century. As mentioned above, that no miracle was collected in St Margaret’s collection after 1263 is also understood in this context.

St Margaret’s *Miracula* indicate that a majority of pilgrims and those invoking the saint were from the Dunfermline area and its hinterland. This means that the cult of St Margaret was really a localized regional cult. The *Miracula* also demonstrates that relatively many monks of Dunfermline received the saint’s miracle, which may have occurred prior to 1150. This presumably corresponds to the circumstance of the abbey securing strong royal patronage and less lay benefaction at that time. However, the pattern showing the *Miracula* - focusing on the locals and monks of Dunfermline - can be changed, when monks and a prior of Dunfermline, and priests are excluded from the list of miracle recipients. That is, the cult turns out to be female focused one and spread throughout Scotland and even up to England.

---

<sup>232</sup> Koopmans, *Wonderful to Relate*, 134.

<sup>233</sup> *Ibid*, 125.

<sup>234</sup> *Ibid*, 201-2.

Moreover, alongside Dunfermline Abbey's location at the heart of networks of roads and the ferry, and the sustaining royal favour, although it was changeable, the miracles concerning King William in 1199, the battle of Largs in 1263, and St Margaret's prophesy of the Scot's retaking of Edinburgh castle during the Wars of Independence could place the cult of St Margaret at the nationwide level, and demonstrate that the cult became a widely popular cult. In particular, as Michael Penman points out, Scottish soldiers' faith in St Margaret in battle - for example, at the battle of Rosslyn in 1303, Bannockburn in 1314, and Neville's Cross in 1346, and during the fourteenth century when Edward I and Edward II had fought against the Scottish kings<sup>235</sup> - may signify that the cult of St Margaret spread widely among the Scottish populace rather than attracted people from the localized area.

It is also worthy of note that the monks of Dunfermline Abbey seem to have intended to develop the cult of the saint. Miracles would still have been a crucial motive to draw pilgrims' attention and to promote the cult of the saint even after obtaining canonisation, and although miracles became less valuable in the relationship with the canonisation process from the last third of the thirteenth century. A very high proportion (89%) of St Margaret's miracles occurred in the abbey at Dunfermline and thus presumably encouraged pilgrims to undertake pilgrimage to Dunfermline, which was probably intended by the monks of Dunfermline in order to encourage the cult of St Margaret. In the same context, it is also understood that of St Margaret's miracle stories none the saint's specific relic objects such as the shirt, the gospel book and the holy cross, which were presumably royal possessions and are known from later sources: these omissions were probably intended to focus on the saint's

---

<sup>235</sup> Michael Penman, 'Faith in war: the religious experience of Scottish soldiery, c.1100-c.1500', *Journal of Medieval History*, vol. 37(3) (2011), 295-303. For the battle of Bannockburn see Duncan ed., *The Bruce - John Barbour*, 425, 468. For the battle of Rosslyn in 1303 see *The Original Chronicle of Scotland*, Andrew Wyntoun, ed. David Laing, 3 vols. (Edmonston and Douglas, 1879) [hereafter *Chron. Wyntoun* (Laing)], vol. ii, 357. For the battle of Neville's Cross in 1346 see Rollason, 'Spoils of War? Durham Cathedral and the Black Rod of Scotland', 57-65. For during the 14th century see M. Prestwich, 'The Piety of Edward I', in W.M. Ormrod ed., *England in the Thirteenth Century* (Nottingham, 1985), 120-8; W. M. Ormrod, 'The Personal Religion of Edward III', *Speculum* vol. 64, no. 4 (October 1989), 849-77.

shrine(s), dust and well in order to lead the pilgrims to visit Dunfermline. The effort of the monks of Dunfermline to promote the cult is found in the strategic choice of the date of the saint's translation on 19 June 1250, just before Mid-Summer when it was a good season for the laity to visit Dunfermline, and which split the year in two alongside the date of St Margaret's death on 16 November. Moreover, the 1180 translation, which could show off the prosperity of the cult, provide the shrine with more space and allow pilgrims to access the shrine easily, and the miracle engaging William I in 1199, which was presumably intended to remind the king of St Margaret's intercessory power and return his attention to Dunfermline, were also relevant to the effort of the monks of Dunfermline to promote or sustain the cult of St Margaret. Therefore, it concludes that the cult of St Margaret spread widely among the Scots, but the monks of Dunfermline made significant efforts at key moments to keep or not to lose the status of the cult of St Margaret.

Map 2. The distribution of the cult of St Margaret in England



## **Chapter 2. Lay patronage and Dunfermline Abbey**

### **(1) Introduction**

Dunfermline Abbey had originated from a priory church at Dunfermline dedicated to the Holy Trinity and founded by Queen Margaret.<sup>1</sup> At the queen's request, Lanfranc (1070-89), archbishop of Canterbury, sent three monks from the cathedral priory of Canterbury to the church at Dunfermline.<sup>2</sup> At that time, the Benedictines were gradually becoming the dominant order in terms of attracting patronage and determining the practice of monastic life in the midlands and south of England, by replacing Anglo-Saxon prelates with the Norman churchmen, who had been deeply influenced by the revival of Benedictine monasticism on the Continent. In Scotland, there was no Benedictine community before the foundation of Dunfermline Priory.<sup>3</sup>

Queen Margaret intended to introduce the new order into Scotland in order to transform traditional Scottish religious customs into those of Western Christendom. Apart from the priory church, Dunfermline was also a significant site as a royal residence by 1070.<sup>4</sup> In geographical and political terms, Dunfermline was crucial to royal authority at that time. By the eleventh century, the power of the kings of Alba/Scotia focused on regions of the east, north of the Forth up to the Tay. However, Malcolm III intended to expand his authority to the southern regions over the Strathclyde Britons in the south-west and the Northumbrians in the south-east. Given his aim to expand the realm, Dunfermline was presumably an appropriate base for the king to carry out his policy, because it was located in the centre of

---

<sup>1</sup> *Vita S Margaretae Scotorum Reginae* (appendix 3 of *Symeonis Dunelmensis Opera et Collectanea*), ed. G.H. Hinde (Durham, 1867), 238.

<sup>2</sup> *The Letters of Lanfranc Archbishop of Canterbury*, eds. Clover and Gibson, 160-3.

<sup>3</sup> Barrow, *The Kingdom of the Scots*, 170; Janet Burton, 'The coming of the Normans' in *Monastic and Religious Orders in Britain, 1000-1300* (Cambridge, 1994), 21-42. However, there were other monastic orders and communities in Scotland such as those at Coldingham, Old Melrose, Dunkeld, St Andrews, Brechin and Iona etc (Cowan and Easson, 'The Development of Monasticism in Scotland', 2-3).

<sup>4</sup> Aonghus Mackechnie, 'The Royal Palace of Dunfermline' in Fawcett ed., *Royal Dunfermline*, 101-38.

the kingdom and relatively close to the southern parts of the kingdom such as Edinburgh.<sup>5</sup> In addition, the geographical location of Dunfermline at the centre of three major places in West Fife dedicated to St Serf (his feast day: 1 July) at Culross, Dysart and Loch Leven - these three religious houses were probably founded about the year 700 - is likely to be a crucial factor for Queen Margaret to choose Dunfermline for the foundation of a new church. Dunfermline was located 10km away from Culross to the east, 23km from Dysart to the west and 15km from Loch Leven to the south.<sup>6</sup> Therefore the geographical distance of Dunfermline from other churches dedicated to the chief saint of West Fife was presumably considered by the queen once she planned to found the first Benedictine house in Scotland, so as to either supplant the native clergy or face less resistance of them. Moreover, as discussed in Chapter One, the main traffic routes near Dunfermline, which facilitated pilgrims' access there, were also a factor in the choice of Dunfermline as the location to found the Benedictine house.

Edgar, Alexander I and David I inherited their father's intention to expand dynastic authority to the south. Just as it was for their father, Dunfermline was a crucial place for them to accomplish the policy in geographical and strategic terms.<sup>7</sup> In this context, it is likely that Dunfermline Abbey was also used as a political centre to make a bond between the crown and regional aristocracy. For example, these were presumably the regional nobles: the earls of Fife, Strathearn, Mar and Atholl, who were named as lay witnesses of David's act issued c.1128, and represented leadership north of the Forth - particularly on the eastern and central highlands and on which in his early reign David's authority relied.<sup>8</sup>

---

<sup>5</sup> *Ibid*, 102; Richard Oram, *Domination and Lordship: Scotland 1070-1230* (Edinburgh, 2011), 28, 41.

<sup>6</sup> Simon Taylor and Gilbert Márkus, *The Place-Names of Fife*, vol. I, *West Fife between Leven and Forth* (Donington, 2006), 224, 348-9, 468. St Serf's *Vita*, which is held in a thirteenth century manuscript kept at Marsh's Library in Dublin, said that there were many staffs relating to St Serf. The saint made four staffs from the True Cross, and it was presumably one of them that a tenant of Pitbauchlie at Dunfermline possessed (Alan Macquarrie, 'Vita Sancti Servani: The Life of St Serf', *Innes Review* 44 (1993), 122-52; Taylor and Márkus, *The Place-Names of Fife*, 349).

<sup>7</sup> Oram, *Domination and Lordship*, 44-5, 55, 68-70, 96-103.

<sup>8</sup> *Registrum de Dunfermelyn*, no. 1; *The Charters of David I*, no. 33; Oram, *Domination and Lordship*, 69-70.

Map 3. Place of the cult of St. Serf in West Fife

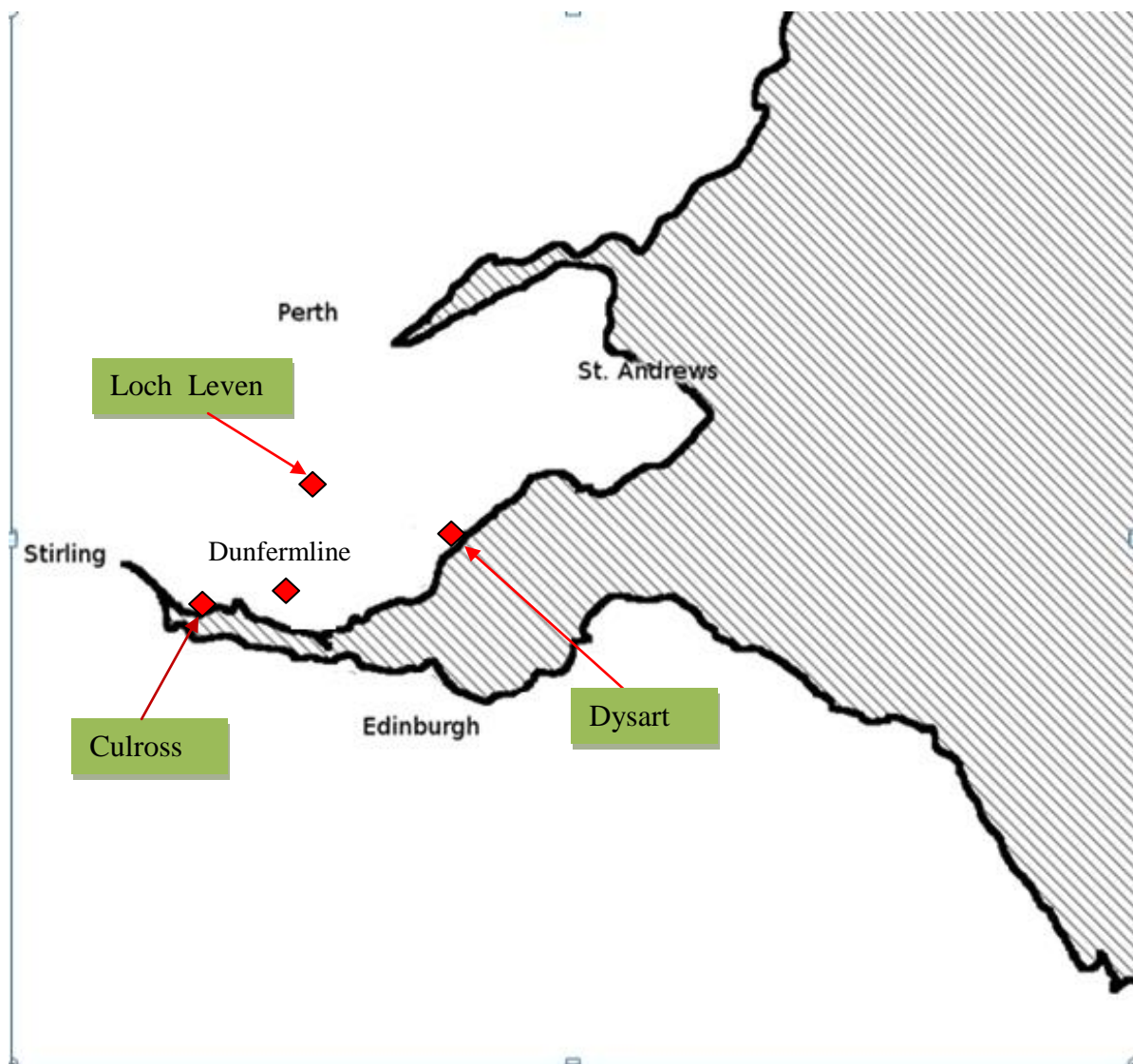

New trends concerning the cults of saints would also have influenced the development of Dunfermline as a royal residence and a royal religious centre. In the late eleventh and early twelfth centuries, the cults of the Trinity and the Blessed Virgin Mary were much emphasised in Scotland, which might have been influenced by the renewed devotion to Christ, the

Passion and Mary throughout Europe.<sup>9</sup> In this context, the cult of St Columba (which had been celebrated by the kings of Alba/Scotia noting that Columba's crosier, the *Cathbuaid*, protected the kingdom of Alba from the invasion of Norwegians in the early tenth century<sup>10</sup>), might have been superseded by other cults such as those of the Trinity and Mary. This shift seems to be relevant to Scottish kings' attempts to make themselves distinct from their predecessors through distancing themselves from the cult of St Columba and Dunkeld Cathedral housing relics of the saint.<sup>11</sup> The importance of the cults of the Trinity and the Blessed Virgin Mary also led monastic foundation in Scotland to be dedicated to paired dedicatees such as the cases of the Augustinian Abbey of Scone (founded 1114x15), dedicated to the Holy Trinity and St Michael; Benedictine Coldingham Priory (x1139), to the Virgin Mary and St Cuthbert; and Tironensian Lesmashagow Priory (1144), to the Virgin Mary and St Machutus.<sup>12</sup> The development/formation of the paired cult of the Trinity and St Margaret, and Dunfermline as a religious community may also have related to these new trends.

As Jamroziak has shown, in the Middle Ages the location of burial was very significant because the place of interment would be determined by several factors such as 'political alliance, social prestige, family tradition and continuity', and the tomb also demonstrated the relationship between 'the person, the family and the monastic community.'<sup>13</sup> Dunfermline had significance to Queen Margaret's offspring, because of the burial of Queen Margaret at Dunfermline, her sons - Edgar, Alexander I and David I - were also buried there.<sup>14</sup> The

---

<sup>9</sup> Matthew H. Hammond, 'Royal and Aristocratic Attitudes to Saints and the Virgin Mary in Twelfth and Thirteenth century Scotland' in Boardman and Williamson eds., *The Cult of Saints and the Virgin Mary in Medieval Scotland*, 61-74.

<sup>10</sup> Thomas Owen Clancy, 'Scottish Saints and National Identities in the Early Middle Ages' in Alan Thacker and Richard Sharpe eds., *Local Saints and Local Churches in the Early Medieval West* (Oxford, 2002), 408.

<sup>11</sup> J. Bannerman, 'The Scottish takeover of Pictland and the relics of Columba', *Innes Review*, 48 (1997), 27-44.

<sup>12</sup> Hammond, 'Royal and Aristocratic Attitudes to Saints and the Virgin Mary in Twelfth and Thirteenth century Scotland', 72. Table 1. For compound dedications see Alison Binns, *Dedications of Monastic Houses in England and Wales 1066-1216* (Woodbridge, 1989), 49-54.

<sup>13</sup> Jamroziak, 'How Rievaulx Abbey remembered its benefactors', 71-2.

<sup>14</sup> Boardman, 'Dunfermline as a Royal Mausoleum', 150.



translation of Malcolm III's relics into Dunfermline would also have reflected their recognition of the importance of Dunfermline. According to English chronicler William of Malmesbury (c.1095/96-c.1143), Malcolm III was firstly buried at Tynemouth Priory nearby Alnwick where he was slain, but later his body was moved to Dunfermline by his son, Alexander I.<sup>15</sup> The translation coincided with the emergence of internal political conflict in the western and northern parts of the kingdom such as in the Hebrides, Caithness and Orkney.<sup>16</sup> In this context, the purpose of the translation was presumably to strengthen the authority of Alexander against internal political challenges. In fact, dynastic concerns had been raised initially in 1093 between Donald Bán, Malcolm's brother, and Duncan II, the son of Malcolm's first marriage. In 1094 Duncan II was buried at Iona believed to be the place of royal interments in the ninth, tenth and eleventh centuries. About 1099 Donald Bán was interred at Dunkeld, which housed the relics of St Columba, and later his remains were moved to Iona. However, Edgar I, who replaced his uncle, Donald Bán, and who was the son of Malcolm and Queen Margaret, was buried at Dunfermline in 1107. His burial at Dunfermline suggests that the church had significance for the sons of Malcolm and Margaret. Edgar would have intended that his action made a distinction between the offspring of Margaret and others. Edgar's favour to Dunfermline could lead us to speculate, as Richard Fawcett suggests, that in addition to the ongoing construction of Dunfermline church initiated by Queen Margaret, the church was extended by Edgar.<sup>17</sup> Alexander I (1107-24) may also have intended to take exclusive claim to their father's right and status as a king through reintering his father at Dunfermline. Miracles attributed to Queen Margaret in the 1090s would also have encouraged her sons to venerate their mother and the church at Dunfermline. It is known that when Queen Margaret's remains were moved from Edinburgh castle to

---

<sup>15</sup> William of Malmesbury, *Gesta Regum Anglorum: The History of the English Kings*, i, eds. Mynors, Thomson and Winterbottom, 464-5; *John of Fordun's Chronicle of the Scottish nation*, ed. W. F. Skene, 208; *ESSH*, ii, 53.

<sup>16</sup> Oram, *Domination and Lordship*, 59-63.

<sup>17</sup> Boardman, 'Dunfermline as a Royal Mausoleum' 141; Fawcett, 'Dunfermline Abbey Church', 31.

Dunfermline in 1093, a miracle occurred; ‘a cloudy mist surrounded that whole family, and miraculously protected them from being seen by the enemy’, that is, Donald Bán who was Malcolm III’s brother and had laid siege to Edinburgh castle with his troops in order to usurp the throne after the death of Malcolm III.<sup>18</sup>

It is also suggested that internal dynastic rivals, in particular the MacWilliams, led the kings to promote the cult of St Margaret. From the beginning of the reign of David I, the most potent rival for David’s throne was his half-nephew, William son of Duncan. Since William was of the senior legitimate male line of Malcolm III, he should have taken the throne, if primogeniture was applied. Thereafter, the MacWilliams became dynastic rivals until Alexander II defeated and destroyed them in 1234.<sup>19</sup> Meanwhile, it was presumably necessary for the crown to uphold dynastic continuity and sacral kingship through St Margaret to counter internal challenges.

The royal association with St Margaret was also affected by the relationship between Scotland and England. For example, the aid of King William Rufus of England (1087-1100) to reclaim his throne against Donald Bán and Duncan II would have made St Margaret more attractive to Edgar (1097-1107) because of her Saxon lineage.<sup>20</sup> This may not perhaps have been the case with Alexander I, who clashed with King Henry I of England. However, unlike Alexander I, David I kept peace with England until he invaded England c.1138 on behalf of his niece Matilda, daughter of Henry I.<sup>21</sup> Under the peaceful relationship between David and England until c.1138, cemented by Henry I and his Queen Matilda, David’s sister, St Margaret would have connected again with Saxon/Norman kings of England, which was, as

---

<sup>18</sup> *Chron. Bower*, iii, 77-9. A miracle also happened, while David’s body was moved to Dunfermline in 1153: while King David’s corpse en route to Dunfermline was crossed the sea, it became calm. However, when the body left the beach, the waves at sea began to be fierce (*CDS*, ii, 116).

<sup>19</sup> Oram, *Domination and Lordship*, 64, 140-3, 155-8, 174-8, 186-93; Richard Oram, ‘Introduction: An overview of the reign of Alexander II’ in Richard Oram ed., *The Reign of Alexander II, 1214-49* (Boston, 2005), 41; Richard Oram, *Alexander II, King of Scots 1214-1249* (Edinburgh, 2012), 96.

<sup>20</sup> Oram, *David I*, 46; Oram, *Domination and Lordship*, 44-5.

<sup>21</sup> *Ibid*, 56-63; 63-4, 72-3, 91-5.

discussed below, exemplified by Turgot penning a *Vita of Margaret* for Matilda and David's prayer requests at Westminster.

Just as a religious community obtained its founder's favour, so the church at Dunfermline received Queen Margaret's special support. As to the generation of her offspring, given Queen Margaret's influence on her sons and Dunfermline's significance in political and geographical terms, it was not surprising that the queen's offspring also gave their favour to the church, as mentioned above, in order to enhance authority and legitimacy. The Canmores' patronage to Dunfermline would have encouraged more laity to favour Dunfermline so as to be close to the Canmores, and which may have related to the nobility's desire to enhance their own local authority. Alongside this political purpose, from their spiritual piety both the crown and the nobles gave grants to Dunfermline in order to seek salvation of their souls such as the cases of David I, Malcolm IV, Walter Fitz Alan and Malcolm, 7<sup>th</sup> earl of Fife as discussed below.<sup>22</sup>

When the founder and the close family of the founder passed away, it was not unusual for a religious house to lose the interest of the founder's descendants. It is also possible for the religious community to restore its status under some circumstances. That is, the status of religious houses was changeable according to the circumstances they faced. Dunfermline Abbey also shows the ebb and flow of its status over a period of time. This chapter will trace the vicissitude of the status of the church at Dunfermline. When, how and what affected the ebb and flow of its status? To explore this pattern, the patronage of the Scottish kings from David I onwards to Dunfermline Abbey, along with the lay patronage from non-royals to the abbey and the effort of the monks at Dunfermline to promote or maintain the cult of St Margaret will be examined in chronological order.

---

<sup>22</sup> *Registrum de Dunfermelyn*, nos. 3, 12, 26, 27, 31; 35, 36, 37, 38, 39, 44, 49; 161, 163; 144, 145.

The reason that the reign of David is a starting point to examine the relationship between Scottish kings and Dunfermline Abbey partly relates to the source, the *Registrum de Dunfermelyn* edited by the Bannatyne Club in the nineteenth century, recording the charters issued from the reign of David I onwards. This survey will be covered up to the reigns of Robert II (1371-1390) and III (1390-1406), who opened a new dynasty, the Stewarts, extending until the period of the last royal interment, that is, Albany's burial at Dunfermline in 1420. Therefore, this chapter will examine how far each king was dedicated to Dunfermline Abbey, how the laity expressed their favour to the abbey, and how the monks of Dunfermline tried to sustain and encourage the cult of St Margaret. To accomplish these aims, the abbey will be compared with other religious houses at a similar level through understanding of each king's piety and dedication to other religious houses, and the patronage of the non-royal laity. However, it should be noted that since there is no extant direct evidence concerning the patronage of the laity to Dunfermline during the reigns of David I and Malcolm IV, the favour of the laity to the abbey from the reign of William I could be examined. Moreover, generally speaking, since lay witnesses named on the royal acts were persons of significant importance in the regions where the acts mentioned,<sup>23</sup> lay witnesses of royal acts for Dunfermline could suggest which laymen had relationship with the church at Dunfermline.

---

<sup>23</sup> *RRS*, i, 78-9.

## **(2) David I (1124-53)**

David I has been considered as ‘the king who made Scotland’, as Richard Oram has demonstrated. David has been reputed as a king who introduced feudal tenure into Scotland, transformed villages into royal burghs in order to develop industry and commerce, and began to organize administrative districts such as shires and sheriffdoms.<sup>24</sup> In addition to his image as a secular revolutionary, he has also been presented as a pious king. It is not difficult to find evidence that David’s contemporary writers praised his piety. In around 1134, Cistercian St Bernard of Clairvaux (1090-1153) wrote to David,

your fair renown has for long stirred in me the desire to meet you in person. This is my desire and relying on the words, ‘The Lord has heard the desire of the poor’, I am confident in the Lord that one day I shall see you in the body whom even now I delight to gaze upon in spirit and imagination, and who I constantly think of with such pleasure and joy.<sup>25</sup>

Cistercian abbot Ailred of Rievaulx (1147-1167) also left his eulogy on David I, in which, as Joanna Huntington has pointed out, David was described as a non-saintly as well as saintly subject: ‘the religious and pious king David has departed from the world; and though he has found a place worthy of such a soul, yet his death imposed grief upon us....’ He also described David as a ‘gentle king, just king, chaste king, humble king.’<sup>26</sup> Moreover, popes expressed their admiration for David’s religious acts. Pope Urban III (1185-1187) depicted the king as ‘a catholic sovereign and one who enlarged the Christian faith.’ Pope Innocent II (1130-1143) extolled David’s ‘goodness toward the monks of Westminster Abbey’, which involved a celebration for his sister and his parents, that is, David’s annual grant of 30s. to

---

<sup>24</sup> Oram, *David I*, 203.

<sup>25</sup> Bruno Scott James trans., *The Letters of St Bernard* (Stroud, second edition, 1998), no. 172.

<sup>26</sup> Ailred of Rievaulx, *Epistola* in Alan O. Anderson, ed., *Scottish Annals from English Chroniclers AD 500-1286* (London, 1908), 232. Joanna Huntington, ‘David of Scotland: ‘vir tam necessarius mundo’ in S. Boardman; J.R. Davies; and E. Williamson eds., *Saints’ Cults in the Celtic World* (Woodbridge, 2008), 130-45.

Benedictine Westminster Abbey so as to celebrate the anniversaries of his sister Queen Matilda (d.1118) and of his father and mother (d.1093) in about 1118 and 1141.<sup>27</sup>

It is natural that as a son of the pious Queen Margaret, David's piety and interest in religion originated from his childhood. In addition, his experiences in England as a young man would have affected his attitude toward the church. The king was brought up at the English king's court probably from 1093 when Henry I succeeded the English throne and married Matilda, David's sister.<sup>28</sup> While he stayed there, David would have been affected by his sister, Queen Matilda, who earned a reputation for her piety and spiritual devotion, and was considered to be almost equivalent to that of her mother. It was also Queen Matilda who requested that Turgot write the life of her mother in order to venerate her. Turgot said that 'you [Queen Matilda] have, by the request you made to me, commanded me to offer you in writing the story of the life of your mother [St Margaret], whose memory is held in veneration.'<sup>29</sup> The deep piety of Queen Matilda led her to be locally regarded as a saint for a while after her demise, and her cult was celebrated at Westminster Abbey, in which she was buried in 1118, even if the devotion was soon abandoned. David's dedication to Westminster Abbey to celebrate her anniversary had no doubt mirrored her influence on the king.<sup>30</sup> He would also have been influenced by the English king's religious patronage and religious politics,<sup>31</sup> which seems to have taught him how to exploit religion in political and administrative terms. David would also have had association with Anselm, archbishop of

---

<sup>27</sup> G.W.S. Barrow, 'David I of Scotland: The Balance of New and Old' in *Scotland and its Neighbours in the Middle Ages* (London, 1992), 47. For Pope Innocent II see *RRS*, i, no. 319.

<sup>28</sup> Barrow, *The Kingdom of the Scots*, 157.

<sup>29</sup> Turgot, *Life of St. Margaret, Queen of Scotland*, 19. For Matilda see Lois L. Huneycutt, *Matilda of Scotland: A Study in Medieval Queenship* (Woodbridge, 2003).

<sup>30</sup> Oram, *David I*, 145, 159. Just as Queen Margaret and Malcolm had been reported to wash the feet of the poor by Turgot, so by the mid-twelfth century it was believed that Matilda washed the feet of lepers, and that her brother David I witnessed it (Turgot, *Life of St. Margaret, Queen of Scotland*, 61; Ailred of Rievaulx, 'Genealogia Regum Anglorum' in *Patrologia Latina*, ed. J.P. Migne (221 vols., Paris, 1844-1903), cxcv, col. 736; Mason, *Westminster Abbey and its People, c. 1050-1216*, 280-2, 301-2).

<sup>31</sup> Judith A. Green, *Henry I: King of England and Duke of Normandy* (Cambridge, 2009), ch. 12. 'Guardian of the church', 254-83; William M. Aird, "'Sweet Civility and Barbarous Rudeness" a View from the Frontier, Abbot Ailred of Rievaulx and the Scots' in Steven G. Ellis and Lud'a Klusakova eds., *Imaging frontiers, contesting identities* (Pisa, 2007), 62-3.

Canterbury (1093-1109), who was a successor of Archbishop Lanfranc.<sup>32</sup> The experience with reformist Archbishop Anselm would have inspired him with a plan concerning the church.

David launched his scheme to found several religious houses soon after he was inaugurated. In 1128 David transferred Kelso Abbey from Selkirk. In fact, David as earl of Northumbria had founded Selkirk Abbey of Tironensians in 1113 and given the abbey his patronage.<sup>33</sup> David founded other abbeys including Augustinian Holyrood Abbey in 1128. The abbey seems to have obtained the Black Rood, which was believed to include a part of the cross of Christ owned by Queen Margaret from Austria.<sup>34</sup> No more religious houses were established by David until he founded Melrose Abbey in 1136. In those days, the king seems to have been attracted to the Cistercians' austerity, which may have been close or identical to David's monastic ideals. The order had been founded by St Bernard, following the principle of the Rule of St Benedict. Cistercian monasteries were placed in remote regions away from the secular world and they renounced all resources from the property of parish churches or other rights and privileges. In the same context, Cistercian monasteries in Scotland - Melrose Abbey (1136), Newbattle Abbey (1140), Dundrennan Abbey (1142) and Kinloss Abbey (1150) - which were founded by David perhaps received relatively fewer grants from the

---

<sup>32</sup> Oram, *David I*, 146.

<sup>33</sup> *The Charters of King David I*, no. 14. Why David chose Tironensians rather than Augustinians as the first abbey he founded is perhaps because of his recognition of the Tironensians' severity of life and their high craft skills, which he had learned from Henry I, a patron of Bernard of Tiron. The attempt to have a royal monastery close to a royal burgh, along with an opinion of John bishop of Glasgow on Selkirk's unsuitability in geographical terms, may have led to the transfer of the Tironensian abbey to Kelso (Barrow, *The Kingdom of the Scots*, 158, 180-1. Along with Kelso Abbey, there was another Tironensian priory, that is, Lesmahagow Priory, which was founded by David in 1144 (Cowan and Easson, *Medieval Religious Houses: Scotland*, 69)).

<sup>34</sup> *Ibid*, 75. For the Black Rood see *ESSH*, ii, 171. David also founded other Augustinian communities such as Jedburgh Abbey (1138), Cambuskenneth Abbey (1140), St Andrews Priory (1144). And St Serf's Inch Priory was founded by the canons of St Andrews at David's request in 1150 (*Ibid*, 77, 74, 82, 78). For a historical context regarding the foundation of Augustinian communities during the reign of David I see A.A.M. Duncan, *The Kingship of the Scots 842-1292: Succession and Independence* (Edinburgh, 2002), 91; Oram, *David I*, 161-2.

king,<sup>35</sup> even if the entire patronage of David to these abbeys is presumably not extant. With the foundation of new orders above-mentioned, David intended to make Scotland a ‘spiritually affluent society’.<sup>36</sup>

Despite several monasteries established by David, the earliest act issued by the king to renovate the Scottish church was for the scheme concerning Dunfermline Priory,<sup>37</sup> which would have mirrored the king’s intention to put Dunfermline at the top of his priorities. David may have thought that since the status of the priory was not suitable as a burial place for his parents and brothers, then elevation to abbatial status was necessary. To do this, David gave Dunfermline Priory material support. In particular, he let Dunfermline Priory concentrate on its building project, ordering the king’s grieve of West Fife to give all the customary services to Dunfermline Priory and help to build the new abbey church for the Benedictines of Dunfermline between 1124 and 1128; and allowing the church to be free

<sup>35</sup> Cowan and Easson, *Medieval Religious Houses: Scotland*, 74-7. For Cistercians’ practical contribution in Scottish society see Oram, *David I*, 162-4. For the foundations by David I see Hammond, ‘Royal and Aristocratic Attitudes to Saints and the Virgin Mary in Twelfth and Thirteenth century Scotland’, 72. Table 1.

Foundations by David I		
Religious house	Date of foundation	Order
Selkirk/Kelso	1113/1128	Tironensian
Holyrood	1128	Augustinian
Urquhart	1130x50	Benedictine
Melrose	1136	Cistercian
Coldingham	x1139	Benedictine
Cambuskenneth	1140x7	Augustinian
Jedburgh	1147x51	Augustinian
Newbattle	1140	Cistercian
St Andrews	1140	Augustinian
Lesmahagow (founded with John, Bishop of Glasgow)	1144	Tironensian
Loch Leven	1152x3	Augustinian
Isle of May	x1153	Benedictine
Kinloss	1150	Cistercian
Berwick	x1153	Cistercian nuns

<sup>36</sup> Duncan, *Scotland*, 144.

<sup>37</sup> *The Charters of King David I*, 53-62.



from all customary service on castles, bridges and other works between 1128 and 1136.<sup>38</sup> Moreover, probably between 1126 and 1127 David requested William of Corbeil, archbishop of Canterbury, and the convent of Canterbury Cathedral Priory, to send a monk who would be the first abbot of Dunfermline. David's intention to keep the Scottish church independent from the English church was demonstrated in this case. At his request, he intended to make it clear that Canterbury Cathedral would be Dunfermline Abbey's sister church rather than a mother church. At last, Dunfermline Priory was raised to abbatial status in 1128 when Geoffrey, prior of Christ Church of Canterbury, was appointed as the first abbot of Dunfermline by David I.<sup>39</sup> Probably in 1128 at the elevation of Dunfermline Abbey, the crown issued an act to Dunfermline Abbey in order to confirm the grants which had been given by his father and mother and his brothers Duncan, Edgar, Ethelred and Alexander, and to give additional grants.<sup>40</sup> With regard to the confirmation, the grants lasting for several generations sometimes raised disputes in the time of descendants of the original benefactor. To prevent disputes, it was very important to record confirmation of the grants, which would clarify an original gift given by a patron. Therefore, confirmations of the grants of original donors were willingly to be issued by the descendants.<sup>41</sup> Apart from the elevation in 1128, it is known that the building of the abbey was consecrated in 1150,<sup>42</sup> as Barrow has suggested,

---

<sup>38</sup> *Registrum de Dunfermelyn*, nos. 18, 31.

<sup>39</sup> *The Charters of King David I*, 63-4, no. 22. David's request to Canterbury Cathedral Priory and Archbishop of Canterbury is likely to relate to a group of three monks who came from priory cathedral of Canterbury at request of Queen Margaret and laid the groundwork for the new Benedictine church at Dunfermline (*The Letters of Lanfranc Archbishop of Canterbury*, Clover and Gibson eds., 160-3). His request to Canterbury rather than Durham or Westminster, both of which had an association with him, would have been derived from the influence of Lanfranc's *Constitutions*.

<sup>40</sup> *Registrum de Dunfermelyn*, no. 1. Additional grants are as follows: David granted the abbey lands at Dunfermline and Kinghorn in Fife with an eighth of judicial incomes in Fife, and lands at Inveresk in Midlothian; the seventh of seals taken at Kinghorn; tofts in five burghs: Berwick, Edinburgh, Stirling, Dunfermline and Perth, and the church of Perth; a hundred shillings from a rent in England; the tenth part of all the game brought from some place (which is not clearly mentioned); a half of skin of all beasts slaughtered at feasts to be held in Stirling and between Forth and Tay; a cain of one ship; timber from the king's wood for fire and building; salt and iron which would be put into the king's hand at Dunfermline.

<sup>41</sup> Jamroziak, 'How Rievaulx Abbey remembered its benefactors', 68.

<sup>42</sup> *ESSH*, ii, 211; Fawcett, 'Dunfermline Abbey Church', 27-63.

probably on Trinity Sunday of that year, on 11 June<sup>43</sup> - the date was the Octave of the translation which would reportedly take place on 19 June 1250. The consecration was a superb event attended by many significant men including David himself, his son Henry earl of Northumberland, six bishops and two northern earls (Buchan and Mar?), confirming his grants which had been given at the elevation in 1128. In addition to the confirmation, he gifted the church new privileges and property including the estates of Newburn, Fife, and Balchrystie (in Newburn).<sup>44</sup>

Apart from a competent monk to be abbot of Dunfermline and other monks sent to Dunfermline Priory from Canterbury, additionally, masons from Durham played a significant role in the construction of Dunfermline. The designer may have been a master mason, Ailric (*Magister Ailricus cementarisu*), who was given the lands of Ledmacduuegil, later known as Masterton in Fife, in 1153.<sup>45</sup> It is not surprising that David commissioned the masons from Durham to design the project of Dunfermline Abbey, because the Scottish royal family had a close relationship with Durham since Margaret and Malcolm III's lifetime. Malcolm III was the only layman to be present at Durham in 1093 when the foundation stone of the new cathedral was laid. The priorate of Turgot, St Margaret's chaplain and biographer, at Durham also showed the king and queen's close association with Durham. The relationship was carried on by Malcolm III's successors. In particular, Alexander I was the only layman to take part in St Cuthbert's translation in 1104.<sup>46</sup> In addition, David as earl of Northumbria presumably saw Durham masons working for churches in north-east England and then recognized their skills. In this context, it is understandable that the Benedictine abbey of Dunfermline was deeply influenced by the architecture of the Benedictine priory of St

---

<sup>43</sup> *The Charters of King David I*, 136.

<sup>44</sup> *Ibid*, nos. 171-2; *Registrum de Dunfermelyn*, nos. 2-3.

<sup>45</sup> *Ibid*, nos. 35, 39; *RRS*, i. no. 112; Taylor and Márkus, *The Place-Names of Fife*, vol. I, 337.

<sup>46</sup> G.W.S. Barrow, 'The Kings of Scotland and Durham' in David Rollason, Margaret Harvey & Michael Prestwich eds., *Anglo-Norman Durham, 1093-1193* (Woodbridge, 1994), 311-23; Valerie Wall, 'Malcolm III and the foundation of Durham cathedral' in *Ibid*, 325-37; Sally Crumplin,, 'Cuthbert the Cross-Border Saint in the Twelfth Century' in Boardman, Davies and Williamson eds., *Saints' Cults in the Celtic World*, 119-29.

Cuthbert at Durham, as discussed in Chapter Three. However, it cannot rule out that the masons coming from Durham and being commissioned to build the ‘David’s church’ were also aware of other buildings, because the master mason was trained in East Anglia.<sup>47</sup>

Since Dunfermline Abbey was the burial place of his parents and brothers, it is certain that the abbey was special to David. The number of extant acts issued during David’s reign gives us an insight into the significance of the abbey to him. Of 216 extant acts David issued, Dunfermline Abbey was the grantee of 29 acts (13.4%), the number of which far exceeded that of other religious houses.<sup>48</sup> Lay witnesses on these acts indicate that the earl of Fife, in particular, seems to have a close association with Dunfermline, appearing as a lay witness on twelve occasions, which was natural, given that Dunfermline is located in Fife. Following the earl of Fife were the earls of Mar and Atholl respectively who appeared on two occasions; and the earls of Ross, Strathearn and Buchan named on one occasion. There were also lords from further afield: the lord of Duddingston was listed on the witness list on three occasions and Tranent was named on one occasion. Both regions are located nearby Edinburgh and in East Lothian, which coincide with the geographical distribution of land David granted to Dunfermline as discussed below. In addition to them, lords of Allerdale (in Cumbria), and Liddesdale (at Roxburgh) appeared on one occasion,<sup>49</sup> although no lesser Fife noble appeared.

The king’s particular favour to the abbey is found in his requests that monks of Dunfermline would pray for the salvation of his father, mother, brothers, predecessors,

---

<sup>47</sup> Eric Fernie, ‘The Romanesque Church of Waltham Abbey’, *Journal of the British Archaeological Association*, vol. 138 (1985), 48-78.

<sup>48</sup> For instance, nine (4%) to Kelso Abbey (Tironensian); three (1.3%) to Melrose Abbey, five (2.3%) to Newbattle Abbey (Cistercian); seventeen (7.8%) to St Andrews Cathedral, five (2.3%) to Cambuskenneth Abbey, four (1.9%) to Holyrood Abbey, two (1%) to Jedburgh Abbey (Augustinian); six acts (2.7%) issued to St. Andrews’ Priory, Northampton (Cluniac); seven (3.2%) to Coldingham Priory, seven (3.2%) to the priory of the Isle of May (Benedictine); four (1.9%) to Dryburgh Abbey (Premonstratensian); five (2.3%) to Glasgow Cathedral [extrapolated from *The Charters of King David I.*].

<sup>49</sup> For the earl of Fife see *Ibid*, nos. 33, 36, 37, 38, 67, 99, 137, 171, 172, 178, 189. For the earls of Mar and Atholl see *Ibid*, nos. 33, 67, 171. For Ross, Strathearn and Buchan see *Ibid*, 33, 171. For lord of Duddingston see *Ibid*, nos. 18, 33, 36. For lords of Allerdale, Tranent and Liddesdale see *Ibid*, nos. 36, 138, 152.

successors, his son and himself.<sup>50</sup> David's intention to secure the souls' care of his dynasty with monks' prayers went beyond Dunfermline. He requested other Benedictine monasteries to pray for the souls of the royal family: Kelso Abbey; Westminster Abbey; Durham Cathedral Priory; the priory of Isle of May founded by the king; Tynemouth Priory.<sup>51</sup> Other religious houses were also requested to do so. For example, Augustinian St Andrews Cathedral was requested to pray for the salvation of the souls of royal members on six occasions.<sup>52</sup> In general, religious communities were supposed to preserve the memories of their benefactors by several means.<sup>53</sup> In particular, the service for crucial benefactors would have been more emphasised. For instance, the convent of St Cuthbert promised that:

Malcolm and Queen Margaret, and their sons and daughters shall be partaker in all things that be to the service of God in the monastery of St Cuthbert, that is to say in Masses, in psalms and alms, in vigils and prayers and in all things that are of this kind. And for the king and queen individually, from the day of their death there shall be thirty full offices of the dead in the convent, and *Verba mea* shall be done every day, and each priest shall sing thirty Masses and each of the rest ten Psalters; and their anniversary shall be celebrated as an annual festival like that of King Athelstan.<sup>54</sup>

This passage indicates that the monks provided special lay benefactors with extra-prayers, which was definitely a different practice from the Cistercians, noting that from the eleventh and twelfth centuries instead of praying numerous, the Cistercians orders had annual prayer days on 11 January and 20 November for their benefactors.<sup>55</sup> In this context, it can be understood that a majority of religious houses, which as mentioned above David requested prayers for the souls of his parents, predecessors, successors and brothers, were Benedictine houses. Accordingly, Dunfermline would also have provided special liturgical service for

---

<sup>50</sup> *Registrum de Dunfermelyn*, nos. 3, 12, 26, 27, 31.

<sup>51</sup> *The Charters of King David I*. nos. 130, 151, 183; 13, 105, 106; 31[32]; 187; 66.

<sup>52</sup> *Ibid*, nos. 85, 87, 88, 94, 157, 173.

<sup>53</sup> Jamroziak, 'How Rievaulx Abbey remembered its benefactors', 63-76.

<sup>54</sup> *Liber Vitae Ecclesiae Dunelmensis*, ed. J. Stevenson (London, 1841), 73; Barrow, 'The Kings of Scotland and Durham', 314.

<sup>55</sup> Jamroziak, 'How Rievaulx Abbey remembered its benefactors', 72.

David I, his brothers and sisters, and his predecessors and successors. However, unfortunately there is no extant document identifying the service.

The relationship between Dunfermline and David can be seen by the appearance of Geoffrey, abbot of Dunfermline, as a witness to David's acts throughout his reign.<sup>56</sup> David's favour to Dunfermline was probably derived not only from his genuine piety and in memory of his parents and brothers being buried there, but also his strategic purpose. David's entire early grants of royal burgh status focused on south of the Forth such as at Berwick, Edinburgh and Stirling. Exceptionally, Dunfermline along with Perth received royal burgh status before c.1128 north of the Forth.<sup>57</sup> In addition, as far as place-dates of acts during the reign of David are concerned, Dunfermline ranked as the third most frequent place David resided, following Edinburgh and Stirling.<sup>58</sup> The king probably placed Dunfermline as a political centre upon the Forth. In other words, in regional strategic terms, Dunfermline might have been employed as a political centre to execute David's policy, intending that David would have appealed to the nobility of Fife, Atholl and Strathearn to accept new systems such as feudal tenure - for example, David gave and restored to Dunfermline the whole shire of Kirkcaldy, which his parents had granted to Dunfermline but Constantine earl of Fife refused to give it to the abbey; and that new monastic orders and the creation of parishes, which the king introduced.<sup>59</sup> The significance of Dunfermline Abbey during the reign of David may have reflected the geographical distribution of its lands - in Dunfermline, Perth, Stirling, Edinburgh, Midlothian, Fife, Fotherif, Clackmannan, Berwick upon Tweed, Kirkcaldy, Auldearn, Newburn, Haddington and Urquhart - which David gave Dunfermline Abbey. That

---

<sup>56</sup> *The Charters of King David I*, nos. 34, 85, 86, 132, 133, 159, 174, 180.

<sup>57</sup> Oram, *David I*, 81.

<sup>58</sup> Twelve times at Dunfermline; fourteen in Edinburgh; thirteen in Stirling; ten at Roxburgh; six at Kinross; four at Berwick upon Tweed; three at Peebles; two at each Cadzow, Clackmannan, Eldbottle, Forfar, Haddington and Irvine; one at each Aberdeen, Abernethy, Banff, Clunie, Coldingham, Earlston, Glasgow, Kinghorn, St Andrews, Staplegordon and Traquair (*The Charters of King David I*, 22).

<sup>59</sup> D.D.R. Owen, *William the Lion: Kingship and culture, 1143-1214* (East Linton, 1997), 9; Barrow, *The Kingdom of the Scots*, 250, 176-86; Barrow, *Kingship and Unity*, 74-6.

Map 4. Geographical distribution of Dunfermline Abbey's land granted by David I

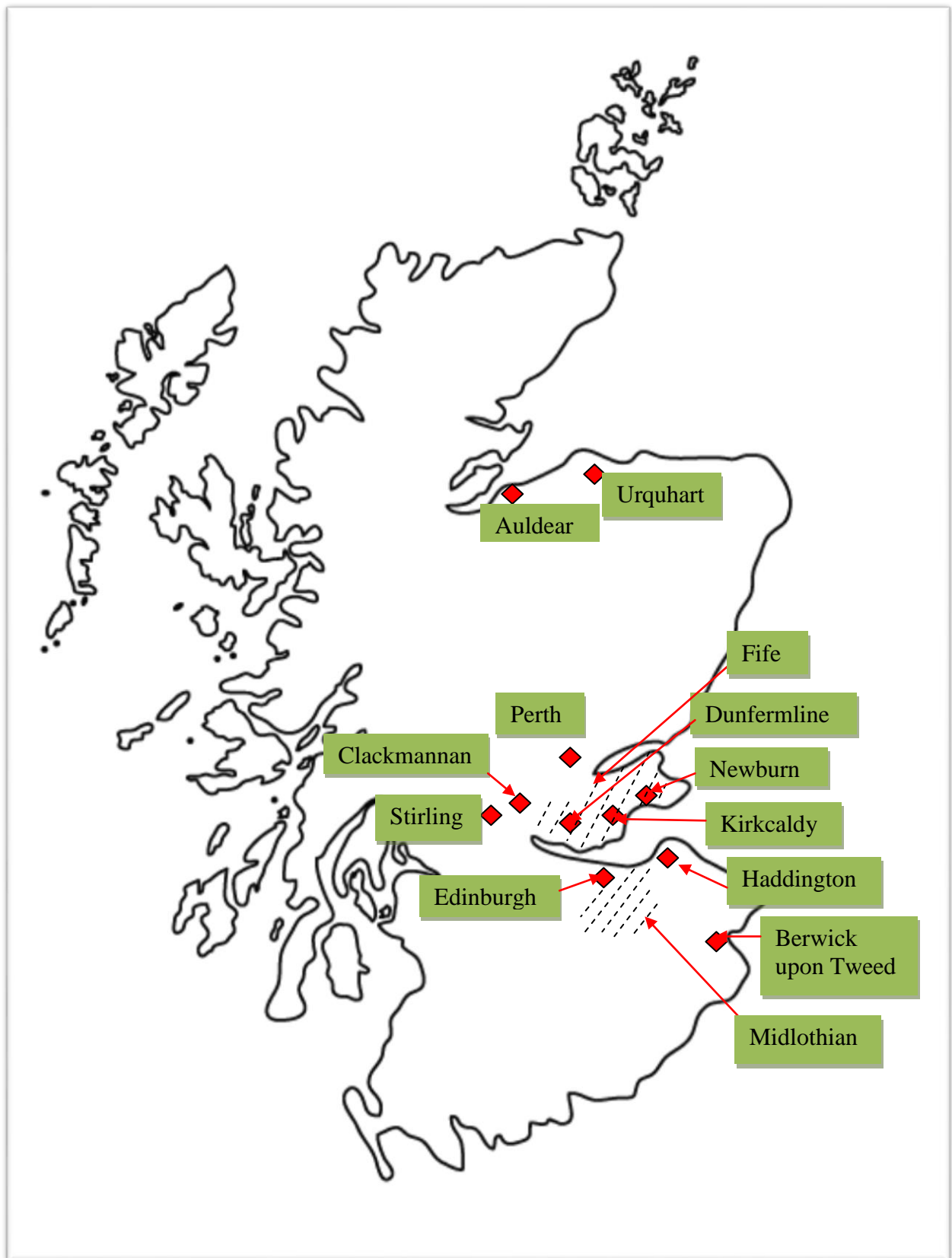

is, those grants to Dunfermline spread over whole regions under his control.<sup>60</sup>

To accomplish David's aim of making Scotland a 'spiritually affluent society', as long as the dynasty is concerned, it might be essential to emphasise the care of souls of the royal family and, as a result, the promotion of the dynastic cult. David raised Dunfermline Priory to abbatial status, gave a number of grants to the church and transformed the eleventh-century church into the Romanesque style, the so called 'David's church'. In other words, the church at Dunfermline is likely to have obtained the material supports to perform the dynastic cult, that is, as a royal mausoleum, by David. However, David's wife, Matilda's (d.1130/1) burial at Scone Priory, which was the traditional inauguration site,<sup>61</sup> as Oram points out, raises a question: why was not she interred at a monastery relevant to herself or her husband such as Daventry Priory or St Andrews at Northampton, her husband's family mausoleum at Dunfermline, or one of the monasteries founded by David?<sup>62</sup> As far as Dunfermline Abbey is concerned, given that in 1130/1 Dunfermline Abbey was at an early stage in both patronage and building in order to promote the dynastic cult and establish the royal mausoleum, it could be understandable that Matilda was not buried at Dunfermline on her death. Like his mother, Henry, son and heir of David, was not buried at Dunfermline. Instead, he was interred at Kelso Abbey in 1152.<sup>63</sup> In spite of it, Henry's participation in the consecration of church building at Dunfermline Abbey in 1150, along with his father, David<sup>64</sup> indicates that Henry would also have accepted David's intention or purposed to follow David's aim to establish the royal mausoleum at Dunfermline Abbey.

On 24 May 1153 - just three weeks before Trinity Sunday, on 14 June - David died at Carlisle and his remains were taken to Dunfermline for burial.<sup>65</sup> During his reign, David's

---

<sup>60</sup> Peter G.B. McNeill and Hector L. MacQueen eds., *Atlas of Scottish History to 1707* (Edinburgh, 1996), 77.

<sup>61</sup> *Chron. Bower*, iii, 135.

<sup>62</sup> Oram, *David I*, 83-4.

<sup>63</sup> *Chron. Bower*, iii, 133; *ESSH*, ii, 218.

<sup>64</sup> *Registrum de Dunfermelyn*, nos. 2-3; *The Charters of King David I*, nos. 171-2.

<sup>65</sup> *ESSH*, ii, 219-20; C.R. Cheney, *Handbook of Dates for Students of English History* (London, 1978), 140-1.

patronage to Dunfermline was presumably enough to develop the cult of St Margaret, which did not require the monks of Dunfermline to secure patronage from other lay people, in particular, non-royals, as discussed in Chapter One. In return, the monks of Dunfermline considered David as a saint and his cult was venerated until the Reformation (1560).<sup>66</sup> Although the monks apparently made little effort to secure non royal patronage c.1124-53, the veneration of David at Dunfermline might have been the way for the abbey to guarantee interest of later monarchs or to encourage lay patronage to the abbey, although there are no extant lay/non royal patronage acts for Dunfermline during the reign of David I.

---

<sup>66</sup> *Chron. Bower*, iv, 3, 251, 285. St David's feast day is May 24, the date of his death (*Butler's Lives of the Saints*, eds. Thurston and Attwater, 383-4).



### **(3) Malcolm IV (1153-65)**

On 27 May 1153, three days after his grandfather died at Carlisle, Malcolm IV was inaugurated as a king.<sup>67</sup> Until Malcolm died on 9 December 1165 at Jedburgh, he preserved his virginity, a vow which led to him being regarded as highly pious. The contemporary writer, William of Newburgh (1136-c.1198), said that Malcolm was ‘a man of wonderful gravity in tender years, of astonishing and unexampled purity upon the summit and in the delights of the kingdom, he was taken from a virgin body to the Lamb, the Virgin’s son, to follow him wherever he should go.’<sup>68</sup> *The Annals of Ulster* also recorded the death of Malcolm IV, eulogizing him as a man of charity, hospitality and piety, and the best Christian of the Gaels by the sea on the east.<sup>69</sup> In his work, the *Vita Waldeni Abbatis* written between 1207 and 1224 and dedicated to William I, his brother earl David, and his heir Alexander II, Jocelin monk of Furness (fl. 1175-1214) emphasised Malcolm’s chastity, praising that the king preserved the ‘virtue of virginity as far as the grave.’<sup>70</sup> However, according to Professor Barrow, since the twelfth century historians have criticized the king’s reputation as a virgin because of his occasional aspiration for knighthood and his military activity.<sup>71</sup> The criticism seems to have been raised on account of ignorance of understanding of a king’s responsibility. Even if a king was highly pious as a human being, at the same time he should fulfil his duty as a king who governed his secular kingdom. To do this, it would have been required of him to take part in martial and marital activities.

---

<sup>67</sup> *ESSH*, ii, 221; Duncan, *The Kingship of the Scots 842-1292*, 71, 74.

<sup>68</sup> William of Newburgh, *Chronicles of the Reigns of Stephen, Henry II, and Richard I*, vol. 1 (London, 1884), 147; Anderson ed., *Scottish Annals from English Chroniclers AD 500-1286*, 243.

<sup>69</sup> *Annals of Ulster*, ed. B. MacCarthy, vol. ii (Dublin, 1893), 148-9; *ESSH*, ii, 261.

<sup>70</sup> *Vita Waldeni Abbatis*, by Jocelin of Furness, *Acta Sanctorum Aug*, iv, 50; *RRS*, i, 23. For a more comprehensive approach to Jocelin’s works see Birkett, *The Saint’s Lives of Jocelin of Furness*.

<sup>71</sup> *RRS*, i, 22-6. On the other hand, Professor Duncan has insisted that Malcolm’s indifference to women may have been caused by an illness he suffered ‘at least from 1163’ (Duncan, *The Kingship of the Scots 842-1292*, 73). However, the king was of age in, or even before 1163, which means that if he wanted, he did not need to keep his chastity. He would have obviously kept his virginity out of piety.

Of 213 extant acts Malcolm issued during his reign, 171 were issued to religious houses.<sup>72</sup> With those acts, he granted his patronage to the churches. This fact led to a conclusion that he gave many grants to religious communities, which would be out of his piety. With regard to his additional religious activities, he made an exceptional plan to take the pilgrim's staff to the shrine of St James at Compostella in 1165, even if this plan did not come to fruition. He also engaged in Becket's dispute with Henry II. Although his attempt was not successful, Malcolm tried to make peace between them in 1165. Moreover, he founded the Cistercian abbey of Cupar-Angus in 1164.<sup>73</sup> As far as Cupar-Angus Abbey is concerned, it was the only abbey founded by Malcolm, who gave the abbey his patronage four times.<sup>74</sup> Given that religious houses received deep affection from their founders, Cupar-Angus Abbey was given relatively fewer grants by its founder. That is probably because Cupar-Angus Abbey was founded in 1164 shortly before the demise of Malcolm. A more plausible explanation may be found by the number of religious communities to which Malcolm granted his patronage. Over fifty religious houses were given grants by the king.<sup>75</sup> Instead of founding more new monasteries, Malcolm seems to have focused on existing religious communities, which had been founded by David I, but whose building operations still carried on or were completed in the reign of Malcolm.<sup>76</sup>

As mentioned above, the religious house to which the most grants were given by Malcolm IV was St Andrews Priory. Malcolm's generosity to St Andrews might have derived from the significance of St Andrews as an Episcopal see, which was involved in a dispute

---

<sup>72</sup> For example, St Andrews (23); Dunfermline (14); Scone Priory (13); Kelso (10); Holyrood (9); St Andrew's, Northampton (6); Durham-Coldingham (6); Reading-May (6); Melrose (5); Newbattle (5); Dryburgh (5) (*RRS*, i, 57-8).

<sup>73</sup> *Ibid*, no. 265. For Becket see *Ibid*, no. 313. For Cupar Abbey see *Ibid*, no. 222; *ESSH*, ii, 252.

<sup>74</sup> *RRS*, i, nos. 222, 226, 227, 282.

<sup>75</sup> Extrapolated from *RRS*, i.

<sup>76</sup> For example, although Melrose Abbey had been founded by David I on 23 March 1136 and the abbey's church was dedicated on 28 July 1146 (D. Broun and J. Harrison, *The Chronicle of Melrose Abbey: A stratigraphic edition. Vol 1, Introduction and facsimile edition* (Woodbridge, 2007), 1), as Richard Fawcett points out, the building at the time of the dedication may have completed just 'the presbytery and eastern parts of the nave to be usable by the choir monks.' To complete the church, decades rather than years were required (Richard Fawcett and Richard Oram, *Melrose Abbey* (Stroud, 2004), 80-4).

with York over metropolitan superiority. Malcolm sent William bishop of Moray to Rome in order to request Pope Alexander III raise the see of St Andrew as an archbishopric. However, Alexander III could not oppose York and King Henry II.<sup>77</sup> Concerning Dunfermline Abbey, just as David had confirmed the grants to Dunfermline Abbey which had been given by his ancestors in his first act to the abbey, so Malcolm gave confirmation to the grants which had been given by his predecessors, King Malcolm III, Queen Margaret, King Duncan II, King Edgar, Ethelred, King Alexander, Queen Sibyl and King David. He also confirmed the land of Ledmacduuegil near Dunfermline; he granted the whole head, except the tongue, of all whales or other big fishes caught from the Firth of Forth to the abbey on 19 December 1154.<sup>78</sup> From the heads, oil, used for lights before the altars, or wax was produced. In addition to them, Dunfermline Abbey was also granted or confirmed the following grants: the church of Perth dedicated to St John and the chapel of the castle of Perth dedicated to St Lawrence; one full toft with croft in Clackmannan; the chapel of Inverkeithing (dedicated to the Holy Trinity) and two tofts in Inverkeithing; the church of West Calder (in Midlothian) dedicated to probably St Cuthbert;<sup>79</sup> a toft in Edinburgh; an annual rent of 100s., which would be confirmed by William I on Malcolm IV's death; the church of the Holy Trinity of Dunkeld, which was founded in the early twelfth century and given to Bishop Andrew of Caithness by David I, and dedicated to the Holy Trinity and St Columba. The subordination of Dunkeld's church to Dunfermline might be attributed to Bishop Andrews' career as a monk of Dunfermline.<sup>80</sup>

---

<sup>77</sup> *Ibid*, 14-17; Duncan, *Scotland*, 261-262; *ESSH*, ii, 243.

<sup>78</sup> *Registrum de Dunfermelyn*, nos. 35, 37-38. For Ledmacduuegil, Malcolm announced his giving the land to Dunfermline Abbey in 1153, shortly after the death of David (*Ibid*, no. 39). With regard to the grant of the heads of whales or other large fish, why Malcolm ordered the head to be given, except the tongue, is perhaps that the tongue is the most delicious part.

<sup>79</sup> For the dedications of religious houses see M. Ash, 'The Administration of the Diocese of St. Andrews 1202-1328' (unpublished Ph.D. thesis, University of Newcastle upon Tyne, 1972), Appendix Five: Parish Churches and Parish Chapels in the Diocese of St. Andrews, 381-91.

<sup>80</sup> *Registrum de Dunfermelyn*, nos. 40, 42, 46, 47, 48, 52, 36; *RRS*, i, nos. 157, 163, 178, 165, 185, 229. For the church of the Holy Trinity of Dunkeld see Hammond, 'Royal and Aristocratic Attitudes to Saints and the Virgin Mary in Twelfth and Thirteenth century Scotland', 69-70.

Map 5. Geographical distribution of Dunfermline Abbey's land granted by Malcolm IV

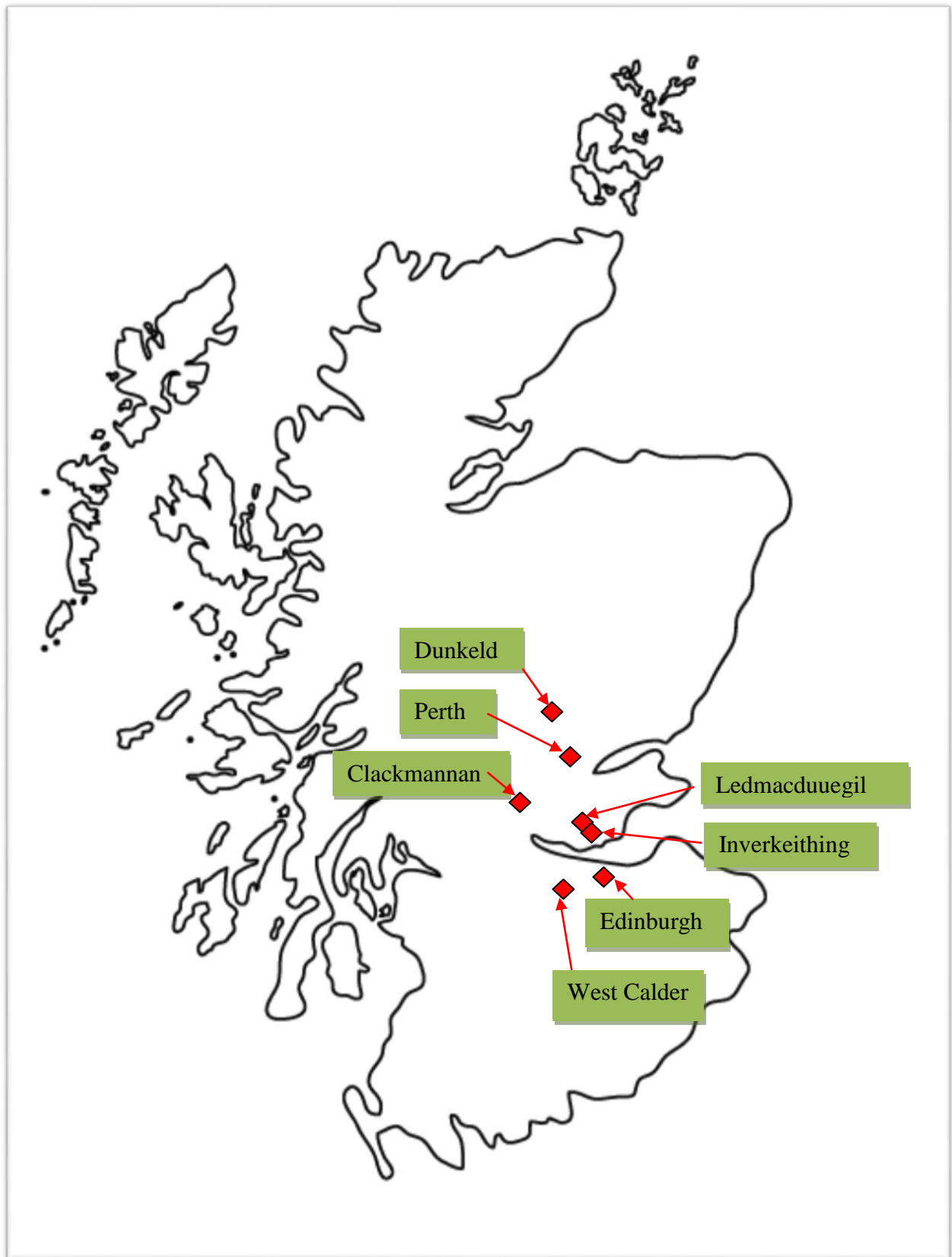

The dedicatees of churches and chapels given to Dunfermline Abbey largely correspond to Dunfermline Abbey's internal altar dedications, and the internal altars were probably set up after the properties were granted to Dunfermline. Geographically the properties and churches given or confirmed to Dunfermline Abbey by Malcolm were placed in Fifeshire, Perthshire, Clackmannanshire and the Lothians, which were largely regions within reach of the abbey as workable lands and resources. Moreover, although there are no extant lay/non royal patronage gifts to Dunfermline, lay witnesses of Malcolm IV's acts for Dunfermline demonstrate that the geographical distribution of the majority of lay witnesses corresponds to that of Dunfermline's properties and privileges granted by Malcolm IV: Duncan II earl of Fife; Cospatric III earl of Dunbar or Lothian; Ferteth earl of Strathearn; Malcolm earl of Atholl; Ness son of William lord of Leuchars (in Fife); Cospatric lord of Dalmeny (in West Lothian) and Merleswain lord of Kennoway (in Fife).<sup>81</sup>

In the acts Malcolm issued to Dunfermline Abbey, he requested the monks to pray for the salvation of the royal family including his predecessors or successors or himself.<sup>82</sup> In addition to this, other religious houses such as St Andrews Priory, Melrose Abbey, Kelso Abbey and others were requested to do so.<sup>83</sup> In these acts the salvation of David I was mentioned most frequently. Among acts issued to Dunfermline, seven acts mentioned the soul of the royal family. Of these seven acts, the name of David I was specified in four. Furthermore, of 34 acts in which Malcolm requested the salvation of the royal family, 14 acts specified the soul of David. The number of Malcolm's requests for David's soul exceeded

---

<sup>81</sup> *RRS*, i, nos. 117, 118, 157, 213; 118, 157, 178, 213; 118, 157; 118; 112, 157; 118; 178. Apart from them, these were named as lay witnesses to charters issued to Dunfermline: Gillbert de Umfraville earl of Northumberland; Gillebrigde earl of Angus; Morgund earl of Mar; Malcolm Maceth earl of Ross; David Olifard lord of Bothwell (in South Lanarkshire); Robert de Brus lord of Annandale (in Dumfries and Galloway); Ranulf de Soules lord of Liddesdale (in Roxburgh) (*Ibid.*, nos. 118, 157; 118; 157; 118; 157; 118, 157, 165, 178; 157; 163).

<sup>82</sup> *Registrum de Dunfermelyn*, nos. 35, 36, 37, 38, 39, 44, 49.

<sup>83</sup> For St Andrews see *RRS*, i, nos. 119, 122, 123, 174, 239. For Melrose Abbey see *Ibid.*, nos. 107, 132, 235. For Kelso Abbey see *Ibid.*, nos. 131, 186, 187. For St Neot Abbey see *Ibid.*, nos. 142, 143, 209. For Newbattle Abbey, see *Ibid.*, nos. 113, 236. For Glasgow Cathedral see *Ibid.*, nos. 114, 265. For the hospital of St Andrews see *Ibid.*, nos. 124, 138; St Frideswide's Priory see *Ibid.*, nos. 224, 225. For Scone Abbey see *Ibid.*, nos. 245, 248. In total, Malcolm requested prayers for the salvation of the royal family in thirty four acts.

that for the salvation of his father, Henry, which was mentioned in eleven acts.<sup>84</sup> This suggests that Malcolm expressed his honour to David who was his direct predecessor, and that Malcolm may have considered Dunfermline Abbey as a cult shrine for David I as well as Margaret. It may be suggested that Malcolm presumably intended further to develop the cult of kingship, just as Henry II developed the cult of Edward the Confessor (1003-66).

Geoffrey II abbot of Dunfermline Abbey was named ten times as a witness of Malcolm's acts, which placed him after Osbert abbot of Jedburgh, who had been a chaplain of David I, and Alured abbot of Cambuskenneth.<sup>85</sup> In other words, even if Geoffrey II's appearances as a witness were infrequent, he was presumably one of the top three figures among the abbots.<sup>86</sup> As far as Osbert abbot of Jedburgh is concerned, he was named 24 times as a witness. Malcolm's relationship with Osbert and Jedburgh Abbey may have reflected the fact that the king died at the abbey on 9 December 1165. Although it is not possible to know whether Malcolm chose Jedburgh as a place for his death or not, the abbey may have been attractive to the dying king. In spite of it, there is no doubt that he intended to be buried at Dunfermline, announcing the grant of an annual 100s. to Dunfermline Abbey in his will.<sup>87</sup> His body was carried to Dunfermline and buried 'before the high altar, on the right of that of King David.'<sup>88</sup> If it was viewed from the altar, Malcolm IV was interred at the north part, a more sacred position. By being laid next to David, Malcolm could have expressed his affection for David I. However, Malcolm died too young to really develop the cult of David I.

---

<sup>84</sup> *Ibid*, nos. 113, 114, 119, 131, 138, 142, 154, 172, 195, 223, 235.

<sup>85</sup> *Ibid*, nos. 131, 136, 159, 176, 192, 195, 239, 240, 241, 243. Osbert was 24 times listed; Alured was 12 times [extrapolation from *RRS*, i. ]. For Osbert see Duncan, *Scotland*, 150.

<sup>86</sup> In this point, since the bishops' influence on a king in secular and ecclesiastical terms was different from an ordinary abbot, it was natural that bishops were listed more times than abbots.

<sup>87</sup> *Registrum de Dunfermelyn*, no. 52.

<sup>88</sup> *John of Fordun's Chronicle of the Scottish nation*, 254.

#### **(4) William I (1165-1214)**

William, who has been reputed to be a king who tried to consolidate Scotland as a ‘cultured and peaceful kingdom within the European family,’<sup>89</sup> seems to have been more than pious. Contemporary and near contemporary writers spoke highly of the king in respect of his saintliness and goodness. Roger of Hoveden (fl.1174-1201) reported how King William kept a vigil in 1199 at the shrine of St Margaret at Dunfermline, where St Margaret persuaded him to give up an attack on England.<sup>90</sup> Gervase of Canterbury (c.1141-c.1210) wrote of William as a man of sanctity. He said that English King John’s troops fighting against Scotland were nervous because God would certainly help William.<sup>91</sup>

However, William’s reputation as a pious man would have been determined by his later life. His earlier life did not show this piety. That his army destroyed the north of England with merciless ferocity under his command or with his approval is a good example demonstrating his harshness. Moreover, even if he remained unmarried until the age of forty, he did not follow the life style of his brother Malcolm IV. Unlike Malcolm IV, William indulged in sexual activity, and he had six bastard children.<sup>92</sup> As his contemporary William of Newburgh noted, William was worldlier than his elder brother and predecessors, and the king ‘postponed the good gift of marriage either for offspring or for the relief of continence.’<sup>93</sup> In

---

<sup>89</sup> Owen, *William the Lion*, 112.

<sup>90</sup> *Chronica Magistri Rogeri de Houedene*, ed. W. Stubbs, iv, 100; *RRS*, ii, 101.

<sup>91</sup> *Historical works of Gervase of Canterbury*, ed. W. Stubbs, *Rolls Series* (London, 1879-80), ii, 102-3. Gerald of Wales (c.1146-c.1223) also had a similar opinion. In his treatise, ‘On the instruction of the ruler’, Gerald illustrated William as a man with ‘leniency and mildness, deep and lasting devotion towards God and holy church, liberal to the poor, pious, provident and peaceful, upholding the law with equity (*Giraldi Cambrensis opera*, ed. J. S. Brewer, J. F. Dymock and G. F. Warner, *Rolls Series* (London, 1861-91), viii, 138-9). The contemporary Icelandic Annals and Alberic of Trois Fontaines (d. c.1254) also remembered William as ‘William the Holy, king of Scots’ (*Islandske Annaler indtil 1578*, ed. G. Storm (Oslo [Christiania], 1888), 23, 63 in G.W.S. Barrow, ‘The reign of William the Lion’ in *Scotland and its neighbours in the Middle Ages*, 70). In addition, Fordun (before 1360-c.1384) collating an earlier St Andrews source stated that William had cured a seriously sick boy with his touch and blessing when he was in York in 1206 with King John (*Chron.Fordun*, i, 279). Edward I touched 995 people while he stayed in Scotland in 1303-4 (Prestwich, ‘The Piety of Edward I’, 124). For the royal touch in the high Middle Ages see Marc Bloch, *The Royal Touch: Sacred Monarchy and Scrofula in England and France*, trans. J.E. Anderson (London, 1973), Book II, ch. I).

<sup>92</sup> Owen, *William the Lion*, 67.

<sup>93</sup> *Chronicles of the Reigns of Stephen, Henry II and Richard I*, ed. R. Howlett, *Rolls Series* (London, 1884-9), i, 148.

addition, until ‘some date between the summer of 1173 and the end of 1174,’<sup>94</sup> the clause *Dei gratia* was not added in all royal acts. The addition of *Dei gratia* was perhaps caused by William’s ambition to demonstrate his authority as a king rather than to express his piety. However, given the legend that Henry II made a pilgrimage of penitence to Canterbury and prayed before St Thomas Becket’s remains when he faced William’s invasion,<sup>95</sup> and that his veneration of St Thomas enabled his army to defeat the Scottish troops and even to capture the Scottish king, the defeat at the battle and his captivity in 1174 may have affected his religiosity and provoked him to establish the abbey at Arbroath dedicated to St Thomas Becket in 1178. Therefore, it could be suggested that around 1174 when William was defeated and captured, and the phrase of *Dei gratia* was introduced to use in the acts, his view on religion seems to have also changed. Also worthy of note is that he, in particular, his piety was influenced by his Chancellors, most of whom were prelates.<sup>96</sup>

The king gave his generous patronage to religious houses such as Coldingham Priory, Kelso Abbey, Melrose Abbey, St Andrews Cathedral Priory and Dunfermline Abbey. In particular, his favourite religious house became Arbroath Abbey, which was founded by the king himself to venerate St Thomas Becket in 1178, along with his wish to promote the salvation of his own soul and those of his ancestors and successors which was probably in part motivated by the death of his mother, the countess Ada de Warenne in 1178.<sup>97</sup> Out of

---

<sup>94</sup> *RRS*, ii, nos. 144-6. Barrow has suggested why *Dei gratia* was added at that time, insisting that the new Angevin practice was probably introduced, and it might have been encouraged by William himself who wanted to demonstrate that ‘he was as much a true king as Henry fitz Empress.’ Barrow argues that the addition of *Dei gratia* began ‘at almost any time after the outbreak of war in August 1173 and possibly not until after the treaty of Falaise at the end of 1174 (*Ibid*, 75-6. Exceptionally the phrase of *Dei gratia* was mentioned in an act of the *Registrum de Dunfermelyn*, which was issued c. 1165-1166 (*Registrum de Dunfermelyn*, no. 50; *RRS*, ii, no. 30)). However, Barrow has not mentioned the relationship between the addition of the phrase of *Dei gratia* in the acts and the capture of William I at Alnwick in 1174, and how his captivity may have affected his religiosity.

<sup>95</sup> Michael Staunton, *The Lives of Thomas Becket* (Manchester, 2001), 34, 217-8.

<sup>96</sup> Nicholas of Roxburgh, who was a Chancellor (1165-71) of Malcolm IV and William; Walter of St Albans (1171-1178) bishop of Glasgow (1208-32); Roger of Leicester (1178-89) bishop of St Andrews (elect, 1189-98, consecrated 1198, d.1202); Hugh of Roxburgh (1189-1199) bishop-elect of Glasgow (d.1199); William de Malvoisin (1199-1202) bishop of Glasgow (1200-2) and bishop of St Andrews (1202-38); Florence of Holland (1203-1210) bishop-elect of Glasgow (d.1210); William del Bois (1211-1226) Archdeacon of Lothian (*RRS*, ii, 520, 535, 527, 506, 536, 500, 489).

<sup>97</sup> Owen, *William the Lion*, 59-60.



around 200 extant acts issued between 1178 and 1214, 55 acts (27.5%) were issued to Arbroath Abbey.<sup>98</sup> Generally speaking, a new abbey was inclined to receive more grants from its founder. This account, however, is unable to provide a full explanation of William's great interest in Arbroath Abbey. The king's favour to Arbroath Abbey dedicated to St Thomas may have related to his reaction to Henry II's humble penance at the tomb of St Thomas and the capture of William himself at Alnwick in 1174.<sup>99</sup> William's capture at Alnwick and St Columba's inferiority to St Thomas in intercessory power terms led the king not only to placate St Thomas through his patronage to the saint but also to treat the saint as a potent anti-Plantagenet symbol. St Thomas's superiority over St Columba was explicitly demonstrated by William's grant of the *Breccbennach*, a reliquary of St Columba (521-91), originally held at Dunkeld, to Arbroath Abbey on 28 June at some moment between 1208 and 1211.<sup>100</sup> Penman has suggested a more concrete reason for William's dedication to Arbroath Abbey, insisting that through the dedication to Arbroath Abbey William wanted to demonstrate his 'personal faith in the saint's power as well as, perhaps, a genuine sense of penitence for his invasion.'<sup>101</sup> Or the king intended to show his appreciation for his captivity because he was not killed in the battle.

William's patronage to the church in particular, Arbroath Abbey, might have influenced William's obtaining the Golden Rose given by Pope Lucius III in 1182, which

---

<sup>98</sup> *Ibid*, 119. During his reign, out of 590 extant acts, William issued 24 acts to Coldingham Priory; 37 to Kelso Abbey; 36 to Melrose Abbey; 34 to St Andrews Cathedral; 24 to Dunfermline Abbey throughout his reign (extrapolated from *RRS*, ii).

<sup>99</sup> Strickland, *War and Chivalry*, 65.

<sup>100</sup> Hammond, 'Royal and Aristocratic Attitudes to Saints and the Virgin Mary in Twelfth and Thirteenth century Scotland', 75-6; Stringer, 'Arbroath Abbey in Context, 1178-1320', 120. For William's grant of St Columba's relics see *RRS*, ii, no. 499; David H. Caldwell, 'The Monymusk Reliquary: the Breccbennach of St Columba?', *Proceedings of the Society of Antiquaries of Scotland* [hereafter, *PSAS*], 131 (2001), 267-82.

<sup>101</sup> Penman, 'The Bruce dynasty, Becket and Scottish pilgrimage to Canterbury, c.1178-c.1404', 349. In addition, he points out that 'William's genuine belief in Becket may be indicated by his reported dispatch of (Jocelin) the bishop of Glasgow to investigate the miracle cure of a John of Roxburgh from drowning in the Tweed through St Thomas's intercession (*Ibid*, 349, n. 11; *Materials for the history of Thomas Becket, archbishop of Canterbury*, Robertson, vol. 1, 296-8).'

would have led him to earn his later fame of ‘regal holiness’.<sup>102</sup> Since William was given the Golden Rose, the monarch would have carried it on ceremonial occasions to display and used it as ‘a royal sceptre, and intended it to be considered as ‘a symbolic Aaron’s rod.’<sup>103</sup> In political terms, one more answer can be suggested as to the question of William’s devotion to St Thomas. In spite of Henry’s penitence to St Thomas, the martyr was seen as a symbol of resistance to English royal tyranny to contemporaries. For instance, Stephen Langton (c.1150-9 July 1228) said that ‘St Thomas... did not flinch from challenging the tyrant’s anger...in order to safeguard the Church, to protect his people, and to defend liberty.’<sup>104</sup> Therefore, devotion to St Thomas, even if it might be a symbolic gesture, could be a good method for William, who was forced to fulfil the subordinate terms of the treaty of Falaise (1174) in order to regain his dignity.<sup>105</sup> Indeed, most of William’s grants to Arbroath were given after the issue of Richard I’s ‘quitclaim’ at Canterbury in 1189, which led Scotland to be released from the English king’s over-lordship signed in 1174.<sup>106</sup> Moreover, William I, who had been at Canterbury to participate in Richard I’s court on 2 December (the *regressio de exilio* feast of Becket) 1189,<sup>107</sup> perhaps had an opportunity to obtain a Becket’s relic.

Concerning Arbroath Abbey, a further question is raised: what made William choose Arbroath as a place for the abbey dedicated to St Thomas? In other words, why did he establish the abbey at Arbroath rather than another place? The establishment and the scale of the abbey may have reflected William’s aim to extend his authority into the northern part of the realm. Under his reign, ‘Angus, Mearns and parts of Aberdeenshire experienced in full measure state-making processes that had already paid dividends for the Scottish monarchy in

---

<sup>102</sup> Stringer, ‘Arbroath Abbey in Context, 1178-1320’, 119-20.

<sup>103</sup> Duncan, *Scotland*, 273, 557.

<sup>104</sup> Quoted in A. Duggan, ‘The cult of St Thomas Becket in the thirteenth century’ in Jancey ed., *St Thomas Cantilupe, Bishop of Hereford*, 40-1.

<sup>105</sup> Stringer, ‘Arbroath Abbey in Context, 1178-1320’, 120. He lists references on the issue of Scottish church’s independence in the twelfth century (*Ibid*, 135, n. 21).

<sup>106</sup> *RRS*, ii, nos. 318, 327-8, 332, 339, 355-7.

<sup>107</sup> *Ibid*, 98.

its southern heartland.’ The abbot also played a role as the king’s loyal representative and the abbey was privileged hugely, which contributed its role as a government force.<sup>108</sup> As mentioned above, William’s grant of the *Breccbennach*, a reliquary of St Columba to Arbroath Abbey could be understood in this context. In other words, His grant of the relics of St Columba, who was a national saint of medieval Scotland along with St Andrew, to Arbroath Abbey would have reflected not only a religious but also a political significance purposed by the king. Moreover, the establishment of Arbroath Abbey by the king and his patronage to the abbey might have related to his political purpose to deal with internal dynastic challenges. Additionally, from the practical point of view, Arbroath may have been chosen to found the abbey because of the red sandstone available near Arbroath,<sup>109</sup> which made it easy to supply materials to build the abbey.

As far as religious houses are concerned, while Arbroath Abbey was placed at the top of churches through William’s abundant grants, Dunfermline Abbey’s status as a royal monastery, which had been at a peak in the time of David I and Malcolm IV, obviously declined.<sup>110</sup> In spite of this, the king issued twenty three acts to the abbey in order to confirm and enhance privileges. Nine of 24 extant acts were issued to the abbey during the king’s early reign, that is, before 1174.<sup>111</sup> The moments when two acts were issued at 1195x1199 and 1195x1210 seem to coincide with William’s receiving St Margaret’s vision in vigil in 1199. The acts issued at 1183x95; 1189x1194; 1189x1195; 1187x1195 might be relevant to special celebration of Dunfermline such as the 100<sup>th</sup> anniversary of St Margaret’s (and Malcolm III’s) death in 1193, the 50<sup>th</sup> anniversary of Dunfermline’s consecration in 1200 and

---

<sup>108</sup> Stringer, ‘Arbroath Abbey in Context, 1178-1320’, 127. For privileges see Owen, *William the Lion*, 60.

<sup>109</sup> Alexander Mackie, ‘Sandstone quarrying in Angus - some thoughts on an old craft’, *The Edinburgh Geologist*, 8 (1980), 14-25.

<sup>110</sup> See Table 2.

<sup>111</sup> *Registrum de Dunfermelyn*, nos. 50, 52, 55, 56, 59, 61, 63, 68, 72. Another 15 acts were issued in 1175 or 1176; 1173x1177; 1173x1181; 1183x95; 1189x1194; 1189x1195; 1187x1195; perhaps 1197; 1195x1199; 1195x1210; and probably 1211 (*Ibid*, nos. 70, 67, 64, 62, 73, 51, 65, 58, 60, 66, 69, 57, 71, 54, 53; *RRS*, ii, nos. 156, 163, 164, 166, 242, 304, 305, 321, 337, 396, 409, 463, 495, 500, 502).

the 50<sup>th</sup> anniversary of the death of David I in 1203. In addition, this pattern of issuing acts is perhaps because the king had more interest in Dunfermline Abbey before the foundation of Arbroath Abbey in 1178. Shortly after his inauguration, William gave Dunfermline confirmations of grants given by his predecessors such as 20 acres of arable and one toft in Dunfermline. In particular, the king confirmed the will of his brother, Malcolm IV to render the payment of 100s. yearly as a tribute of his respect to his brother.<sup>112</sup>

In 1180 there was a significant event in the history of Dunfermline Abbey, even if no extant act mentioned it. The St Margaret's *Miracula* describes the translation of Margaret's remains in detail. It took place probably on Trinity Sunday (15 June) 1180,<sup>113</sup> just as the consecration of Dunfermline Abbey in 1150 and, as discussed below, the thirteenth-century translation of St Margaret's remains took place possibly on Trinity Sunday. According to the *Miracula*, the translation was carried out under the leadership of the church of Dunfermline. Chapter nine of the *Miracula* narrates that 'in the year 1180 AD, ....., the thought was sent from above (as we believe) into the minds of the brethren of the church of Dunfermline that they should move the tomb of St Margaret the queen from the place in which it was situated.'<sup>114</sup> Since chapter nine does not refer to the involvement of William in the event, it is not possible to know if the king supported or initiated the translation. Instead, as chapter nine demonstrates, the translation of 1180 was carried out by the monks of Dunfermline on their own initiative to correspond with the promotion of St Margaret's cult and the demand to secure more space for both pilgrims and monks. The translation may also have been a kind of

---

<sup>112</sup> *Registrum de Dunfermelyn*, nos. 50, 52.

<sup>113</sup> Cheney, *Handbook of Dates*, 142-3.

<sup>114</sup> *anno ab incarnatione Domini millesimo centesimo octogesimo, ....., diuinitus immittitur-ut credimus-in animo fratrum Dunfermelensis ecclesie ut mausoleum beate Margarite regine a loco in quo positum erat tollerent (Miracula, 93-5).*

preliminary warning to a shift of William's favour to Arbroath Abbey founded by the king himself.<sup>115</sup>

Chapter nine describes the event further. Monks of Dunfermline Abbey employed an artist called Ralph (who was one of the earliest named artists in Scotland) to build a reliquary 'covered with gold leaf and carved images....' While the translation ceremony was underway, monks prostrated 'on the ground in the choir, and began to recite the seven penitential psalms and the litany.' In the end, the relics were re-enshrined 'at the north end of the altar' raised up on a stone table.<sup>116</sup> Chapter five also describes the translation:

The feast of the blessed queen approached, which is celebrated each year in her memory and in veneration of all the saints whose relics are in the church, on which day the translation of her holy body from the former church to the high altar is commemorated with the great celebration of psalms and hymns.<sup>117</sup>

This passage allows us to speculate that the translation was held on 16 November, if it did not happen on Trinity Sunday 1180 as already suggested, because 'the feast of the blessed queen' was on that day. Writing in the 1440s, Bower also described a miracle, which reportedly occurred at the translation of St Margaret's remains from the nave to the choir and was considered to have happened in 1250: while the remains of St. Margaret were carried, the bearers, who were the bishops and abbots along with the king, could not move when they passed the tomb of Malcolm III, her husband. As soon as the coffin of Malcolm III was also moved, the relics of St. Margaret could be moved.<sup>118</sup> If Bower's description of the translation

---

<sup>115</sup> *Ibid*, 93-5; Michael Penman, 'A Programme for Royal Tombs in Scotland? A Review of the Evidence, c.1093-c.1542' in Michael Penman ed., *Monuments and Monumentality in Later Medieval and Early Modern Europe* (Donington, 2013), 240.

<sup>116</sup> *Miracula*, 93-5, xlii; Yeoman, 'Saint Margaret's Shrine at Dunfermline Abbey', 83.

<sup>117</sup> *Appropinquante enim beate regine festiuitate, que singulis annis ad eius memoriam et ad omnium sanctorum quorum reliquie in eadem continentur ecclesia ueneracionem recolitur, in qua die sacricorporis sui de ecclesia priori ad altare maius translacio, cum magna celebritate psalorum et ymnorum facta commemorator* (*Miracula*, 82-3). Chapter two also refers to the translation: '....according to the decision of our elders, ...the body is kept entombed next to the high altar with great honour to the present day (*Ibid*, 77).'

<sup>118</sup> *Chron. Bower*, v, 296-9.

of both remains of St Margaret and Malcolm III from the nave to choir can be accepted, the miracle in fact happened (first) during the 1180 translation, not that of 1250.

During the night of this translation, three miracles occurred to a local deaf woman, a Scottish blind man and an English girl suffering from a prolonged disease of her arm.<sup>119</sup> The presence of the girl, who would have found it hard to take a trip because of her physical disability, on the occasion of the translation suggests that the translation was a ceremony leading people from even England to Dunfermline. The translation of 1180 would have given monks easier access to the reliquary and control of security and offerings efficiently.<sup>120</sup> Moreover, the translation allowed both new tomb and old tomb to be used as places for veneration, which would have encouraged pilgrims to come to the abbey. The miraculous healing of a woman suffering from toothache occurred on the night of the translation.<sup>121</sup> These miracles would also have provided pilgrims with the motivation to seek the aid of St Margaret. The translation and miracles attributed to St Margaret at the translation provisionally succeeded in drawing the king's attention back to Dunfermline, given the five royal acts for Dunfermline which may have been issued in the 1180s, as already noted.<sup>122</sup> However, Dunfermline could not keep William's attention, which might have led to St Margaret's appearance during William's vigil in 1199 at Dunfermline to persuade him not to attack England.

On 30 April 1182 Pope Lucius III sent a bull of privileges to Dunfermline Abbey,<sup>123</sup> which may have related to the dispatch of William's envoys including Jocelin bishop of Glasgow, Arnold abbot of Melrose and Osbert abbot of Kelso and so on to Rome, and in return Pope Lucius III sent him the Golden Rose on 7 March 1182.<sup>124</sup> From this event, it is

---

<sup>119</sup> *Miracula*, 85-7.

<sup>120</sup> Yeoman, 'Saint Margaret's Shrine at Dunfermline Abbey', 83.

<sup>121</sup> *Miracula*, 93-5.

<sup>122</sup> 1173x1181; 1183x95; 1189x1194; 1189x1195; 1187x1195.

<sup>123</sup> *Registrum de Dunfermelyn*, no. 238.

<sup>124</sup> Duncan, *Scotland*, 272; *RRS*, ii, 24; *ESSH*, ii, 305.

possible to draw the following suggestion: the translation of 1180 and the Papal Bull of privileges of 1182 might have represented a first attempt to seek Margaret's official canonisation, using the miracle stories probably collected around the 1180 translation. It is not known whether Archibald abbot of Dunfermline was sent to Rome as one of William's envoys. However, it is certain that he took part in government service from 1178 to 1198 when he succeeded the post of abbot after the death of previous Abbot Geoffrey II.<sup>125</sup> For example, Abbot Archibald appeared in the list of royal charter witnesses on several occasions.<sup>126</sup>

William's predecessors such as David I and Malcolm IV sometimes asked monks of Dunfermline Abbey to pray for the soul of the royal family in exchange for their patronage to the abbey. However, William barely requested it. Just one act issued to Dunfermline Abbey shows his request for prayers for Malcolm IV's soul in probably 1165 or early 1166,<sup>127</sup> shortly after William succeeded Malcolm IV. It leads to doubt as to whether William considered the abbey as a suitable place for praying for the souls of his predecessors and successors. However, in the acts the king issued to Arbroath, which was his favourite abbey, he requested prayers just twice: when he announced the foundation of Arbroath Abbey in 1178 and when he confirmed privileges of the abbey in 1213.<sup>128</sup> From this fact, it might be said that the mention of the salvation of the royal family in acts was perhaps a matter of writing styles rather than William's preference for a specific abbey. Moreover, fewer prayer requests for the salvation of the royal family might have reflected William's indifference to

---

<sup>125</sup> *Ibid*, 299, 349. Robert, who was 'a monk of the same house', succeeded Archibald and was deposed by legate John in 1202. Patrick, sub-prior of Durham, succeeded Robert. Patrick (1202-1212x1223) seems to rarely participate in royal administration service. He did not appear as a witness in acts of William, but he was mentioned one time in an act regarding Dunfermline Abbey (*RRS*, ii, no. 451).

<sup>126</sup> *Ibid*, 252, 270, 271, 301, 308, 314, 317, 322, 323, 324, 325[2], 327, 329[2], 332, 333, 337, 338, 344[2], 345, 348, 349, 351[2], 355[2], 356, 357, 360, 365, 366, 482.

<sup>127</sup> *Registrum de Dunfermelyn*, no. 52; *RRS*, ii, no. 31.

<sup>128</sup> *Ibid*, nos. 197, 513.

the dynastic cult, unlike David I and Malcolm IV who intended to establish the dynastic cult as mentioned above.

As already noted, the translation of 1180 may indicate that the cult of St Margaret was still thriving in the late twelfth century and required more space for both monks and pilgrims. At the same time, the translation is likely to be a preliminary warning for the loss of royal favour to the abbey, which means that the monks of Dunfermline could see or expect the decline of the abbey's status as a royal monastery. The geographical distribution of grants of William to Dunfermline - focused on Fife (Dunfermline, Kinghorn, Leslie, Kellie and Forthar) - seems to reflect the decline of the abbey's significance, although the abbey's properties and privileges given by William included the regions of Haddington, Stirling, Kirkmichael in Perthshire and Montrose in Angus.<sup>129</sup> In comparison with it, Arbroath Abbey's properties and privileges received from William placed mainly on the regions of Angus and Aberdeenshire, into which William aimed to extend his authority.<sup>130</sup> In other words, Arbroath Abbey played a role as a royal representative throughout the north part of kingdom. In this context, the diminution of Dunfermline Abbey's influence in geographical terms can also be understood: the abbey may have played a role as a royal agency in central and southern regions. William's grants to Kelso Abbey, Melrose Abbey and St Andrews Cathedral Priory, which were higher ranked religious houses regarding the number of grants given by the king, also focused on limited regions rather than the whole realm under the control of William.<sup>131</sup> That is, during the reign of William there was no abbey which could spread its influence

---

<sup>129</sup> *Registrum de Dunfermelyn*, nos. 50, 51, 55, 61, 62, 63, 65, 69, 72, 73; *RRS*, ii, nos. 30, 304, 22, 166, 107, 108, 305, 409, 130, 242.

<sup>130</sup> For Angus see *Ibid*, nos. 197, 198, 227, 229, 230, 231, 223, 234, 277, 280, 284, 327, 328, 355, 408, 416, 453, 454, 455, 456, 457, 466, 487, 503. For Aberdeenshire see *Ibid*, nos. 225, 300, 318, 356, 413, 417, 452, 458, 498, 512, 515, 522, 526.

<sup>131</sup> Most grants of Kelso were based on Roxburghshire, Berwickshire, East Lothian, Dumfries; as to Melrose Abbey, Berwick, Roxburghshire, East Lothian, Dumfries, Lanark; as to St Andrews Cathedral, Perthshire, Fife, Dundee, Aberdeenshire (*Ibid*, nos. 166-9, 187, 190, 201-3, 239-41, 244-5, 279, 282-4, 289, 311-12, 317, 321, 328-30, 349, 362-5, 373-5, 412-13, 417, 440-1, 449-50; 133, 173, 176-7, 180-1, 183, 188-9, 236-8, 249, 262-3, 274-7, 279, 283, 288, 296-7, 311, 318-19, 322, 359-61, 364, 377-8, 380, 402-3, 412-13, 416-18, 441-2, 449-50, 129, 134, 136, 139, 143, 145, 166, 172-3, 196-7, 205-6, 220-2, 231-3, 235, 254-5, 260, 261, 283-4, 335, 336, 337, 348, 409-10, 448).



throughout broad areas under the control of the king. Therefore, as other key religious communities did, the influence of Dunfermline Abbey centred on restricted areas, which was obviously diminished in comparison with relatively wider geographical distribution of grants given by David and Malcolm.<sup>132</sup> Therefore, as far as the geographical influence of Dunfermline Abbey and the proportion of William's grants to the abbey are concerned, the abbey could not draw the king's interest as much as that of previous kings, David and Malcolm IV and, as a result, the status of Dunfermline Abbey as a royal monastery/mausoleum declined in the reign of King William.

The decline of the abbey as a royal monastery/mausoleum corresponded to an increase of lay patronage. It is known that the abbey received patronage from the nobility during the reign of William, perhaps in response to monks' efforts to compensate for loss of royal favour. For example, Walter Fitz Alan, King Malcolm IV's Steward, gave the abbey a gift of 20 acres and a toft on the day of Malcolm IV's burial for the soul of the king and his ancestors, and for the souls of Walter's own parents and his ancestors, for his own soul, and he also gave a toft in Inverkeithing to the abbey in 1168. In 1203 Alicia, grand-daughter of Ranulph third earl of Chester (d.1129) - Earl David of Huntingdon, who was a younger brother of King William I, married a daughter of fifth earl of Chester in 1190 -, gave six acres of land at Cramond to the abbey.<sup>133</sup> In addition to these gifts, the earls also granted their patronage to the abbey. Malcolm earl of Atholl granted the church of Moulin in Perthshire (dedication: St Columba) to the abbey probably in 1180, in return for a significant indulgence - although no extant record concerning the indulgence granted in the 1180 translation remains

---

<sup>132</sup> As to David, Dunfermline, Perth, Stirling, Edinburgh, Midlothian, Fife, Fothrif, Clackmannan, Berwick upon Tweed, Kirkcaldy, Auldearn, Newburn, Haddington and Urquhart. As to Malcolm IV, Dunfermline, Fife, Firth of Forth, Perthshire, Midlothian, Clackmannan, Edinburgh.

<sup>133</sup> *Registrum de Dunfermelyn*, nos. 161, 163, 202. For Ranulph third earl of Chester see Edmund King, 'Ranulf (I), third earl of Chester (d. 1129)', *ODNB* accessed on <http://www.oxforddnb.com/index/101023127>; William Keneddy, *Annals of Aberdeen, from the Reign of King William the Lion* (London, 1818), vol. i, 20.

Map 6. Geographical distribution of Dunfermline Abbey's land granted by William II.

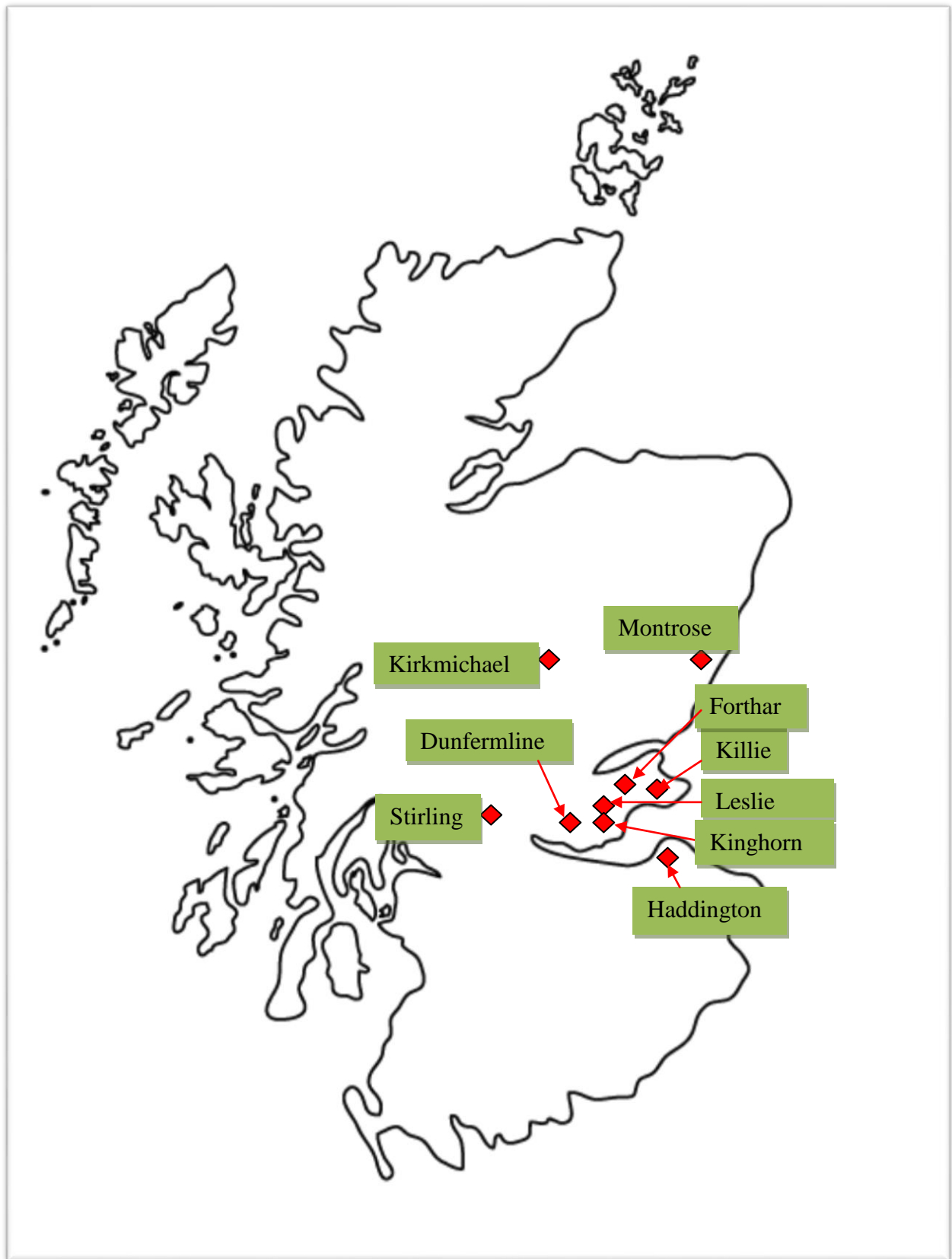

- gaining from the translation. Moreover, the earl and his wife were buried in the abbey at some time probably between 1194 and 1198,<sup>134</sup> just as a noble lady of the late thirteenth century called probably Mariota, a daughter of William de Moray of Aldie (from Moray), and married to member of the Strathbogies (from Aberdeenshire) was interred at Dunfermline, as the surviving effigy remains in the nave of the abbey demonstrate.<sup>135</sup>

There may also be evidence from the *Registrum de Dunfermelyn* suggesting that Dunfermline was financially supported presumably for the 1180 translation. Between 1178 and 1188 Hugh bishop of St Andrews (1178-1188) confirmed the grant of the church of Melville in Midlothian (dedication: St Andrew) given by Geoffrey de Melville Justiciar of Lothian, and the church of Calder Comitis [West Calder] in West Lothian (dedication: probably St Cuthbert) granted by Duncan earl of Fife to Dunfermline.<sup>136</sup> Hugh bishop of St Andrews also confirmed the grant of the churches of Carnbee (Fife, dedication: unknown) and Wester Kinghorn (Fife, dedication: St Serf) to Dunfermline between 1178 and 1188.<sup>137</sup> These grants might also have been relevant to financial support for the translation. Malcolm 7<sup>th</sup> earl of Fife granted the Cleish Chapel (dedication: St Cuthbert) in Perthshire to the abbey c.1208, and the church of Abercrombie (Fife, dedication: St Mary and St Margaret of Scotland) to the abbey for the souls of his parents and his successors, and for his own soul.<sup>138</sup> Earl Malcolm's patronage to Dunfermline might have derived from his intention to be buried there. Unlike the previous two kings, David and Malcolm IV, William's interest in religious patronage turned to other religious houses, which presumably led the monks of Dunfermline to seek additional patronage from the nobility, or to associate closely with the nobility in

---

<sup>134</sup> *Registrum de Dunfermelyn*, no. 147.

<sup>135</sup> Iain Fraser, 'Medieval Funerary Monuments in Scotland' in Penman ed., *Monuments and Monumentality in Later Medieval and Early Modern Europe*, 17, Plate 5.

<sup>136</sup> *Registrum de Dunfermelyn*, nos. 100, 158.

<sup>137</sup> *Ibid.*, no. 99.

<sup>138</sup> *Ibid.*, nos. 145, 144. For the dedications of religious houses see M. Ash, 'The Administration of the Diocese of St. Andrews 1202-1328', Appendix Five: Parish Churches and Parish Chapels in the Diocese of St. Andrews, 381-91; Mackinlay, *Ancient Church Dedication in Scotland*, 7.

order to boost the reputation or the status of the abbey, just as the monks attempted to enhance it through carrying out the translation of St Margaret's remains in 1180 - or the translation was necessary to meet the demand to secure more space. In other words, as far as the extant evidence is concerned, the increase of the nobles' patronage to Dunfermline coincided with the decrease in the monarch's favour to Dunfermline.<sup>139</sup>

If the assumption that lay witnesses of royal acts were generally persons of significance to the regions to which the acts referred can be accepted, it is presumably possible to speculate which nobles had close association with Dunfermline by considering lay witnesses to William's acts for Dunfermline Abbey. Undoubtedly Duncan II earl of Fife, as a person of leading lordship in Fife, showed his relationship with Dunfermline being named as a lay witness on five occasions. William Comyn lord of Lenzie and Kirkintilloch as well as earl of Buchan, Gilbert earl of Strathearn and Maurice earl of Menteith appeared on four, two and one occasion respectively.<sup>140</sup> Compared to the reigns of other kings, the reign of William demonstrates that a number of lords from various regions appeared as lay witnesses in William's acts for Dunfermline, which related to the circumstance of the increase of noble patronage for Dunfermline Abbey.<sup>141</sup> The localities of lay witnesses roughly overlap the geographical distribution of Dunfermline's properties and privileges granted by William,

---

<sup>139</sup> In this point, the case of Dunfermline concerning noble patronage was different from other religious houses such as Melrose Abbey which demonstrates the important characteristic of lay people being buried there. That is, the laity interred at Melrose had 'their association with, and close connection to, the royal court (Jamroziak, 'Making friends beyond the grave', 328-30).' On the other hand, Dunfermline was more granted by the nobles when the abbey lost the king's interest.

<sup>140</sup> *RRS*, ii, nos. 30, 242, 304, 321, 337, 396; 304, 396, 409, 502; 242, 337; 337.

<sup>141</sup> The lords named as lay witnesses are as follows: Philip de Valognes lord of Benvie and Panmure (in Dundee); William de la Hay lord of Errol (in Perth and Kinross); David Olifard lord of Bothwell (in South Lanarkshire); Walter of Berkeley lord of Inverkeilor (in Angus); Ness son of William lord of Leuchars (in Fife); Robert Avenel lord of Eskdale (in Cumbria); Richard Revel lord of Coultra (in Fife); Bernard lord of Hadden (in Dundee); William of Lindsay lord of Crawford (in Clydesdale); the lords of Yester (in East Lothian); Ralph de Clere lord of Mid Calder (in West Lothian); Philip of Seton lord of Seton, Winton (in East Lothian) and Winchburgh (in West Lothian); William II de Viexpont lord of Alston (in Tynedale), Bolton (in East Lothian), Carriden (in West Lothian) and Langton (in Berwickshire) (*Ibid.*, 30, 34, 242, 409, 463, 500, 502; 30, 304, 337, 396, 409; 30, 34, 35, 107, 108; 22, 30, 34, 130, 166; 22, 30, 35, 107; 130, 164, 304; 495, 502; 34, 156; 321, 337; 242, 409; 30; 242; 396).

focusing on the central and southern realm such as Dunfermline, Fife, Edinburgh, Stirling, Perthshire and Haddington, as already noted.

The decline of the abbey's status would also have related to William's decision to seek burial at Arbroath in 1214 and his wife's, Queen Ermengarde's interment at the abbey of Balmerino in 1233, which had been found by herself in 1229.<sup>142</sup> William's reduced interest in Dunfermline Abbey, in particular, no mention of his participation in St Margaret's translation in 1180 indicates two points. Firstly, William might not have recognized the potential of the royal saints and the dynastic cult, which could promote the rise of the monarch's authority as a sacred king by emphasising being a descendant of the saint. Secondly, he probably thought St Margaret not to be superior to St Thomas, to whom he was eager to demonstrate devotion. Dedication to St Thomas led the king to found Arbroath Abbey and his favour was diverted to the abbey. However, in spite of the decline of the status of Dunfermline Abbey as a royal mausoleum, William seems to have wanted to honour the memory of his great-grandmother, because he named both his daughters Margaret.<sup>143</sup> In addition, William asserted St Margaret's sainthood through his personal experience, having seen a vision while he had prayed at her tomb in 1199,<sup>144</sup> or it could be just a story invented by monks of Dunfermline. If the latter is the case, the story was the production of monks' effort to sustain the cult of St Margaret.

---

<sup>142</sup> *ESSH*, ii, 398. For Ermengarde see *Ibid*, 488-9, 469; Cowan and Easson, *Medieval Religious Houses: Scotland*, 72-3. As D. E. R. Watt has estimated, Queen Ermengarde very rarely appeared in Bower's *Chron*. Furthermore, she is not found in the lists of witnesses in extant acts of William (*Chron. Bower*, iv, 623; *RRS*, ii).

<sup>143</sup> *Chron. Bower*, iv, 369, 411, 453, 581-2.

<sup>144</sup> Given the seasonal weather condition for waging a war, it might have been summer when he thought about waging a war against England and was dissuaded from invading England by St Margaret while he kept in night vigil at St Margaret's shrine. If this suggestion is accepted, it might be said that William presumably visited Dunfermline about the Trinity Sunday, 13 June (Cheney, *Handbook of Dates*, 138-9).

### **(5) Alexander II (1214-1249)**

Bower said that Alexander II was a man who was a ‘shield of the church, a giver of peace to his people, a guide to the wretched, a king up-right, strict, wise, prudent, honest, a pious king, a brave king, a most virtuous king, a wealthy king.’<sup>145</sup> In respect of religion, Bower praised the king’s ‘wonderful zeal for the increase of religion, seen especially in his concern with building churches for the Friars Preacher.’<sup>146</sup> However, to modern historians Alexander II has usually been depicted as a political and military king marching his troops into northern England and the western isles under Norse control. In this point, as far as piety is concerned, Alexander II has been judged as conventional, inferior to his father, William I, who was remembered as a man ‘with great religious and large lasting devotion toward God and the cult of holy church’ by chronicles.<sup>147</sup>

In spite of this, it would be a simplistic judgement to ignore Alexander II’s religious activities. Alexander II was involved in the foundation of several abbeys. One of them was Balmerino Abbey, which was established by the king himself and his mother Queen Ermengarde de Beaumont in 1229 for ‘the honour of God, and of the glorious Virgin Mary, and the most holy king Edward’, who was St Margaret’s ancestor. To the abbey a convent from Melrose Abbey was sent, and Queen Ermengarde was later buried there.<sup>148</sup> Another one was Pluscarden Abbey for the Valliscaulians, which was founded in 1230-1 by the king to give thanks for cracking down on the Meic Uilleim’s rebellion and to ask for forgiveness of the violence he committed. He also invited new orders of Mendicant friars, especially the Dominicans, to Scotland and gave them their first convent at Edinburgh.<sup>149</sup> A further 13 religious houses were founded during his reign, even if all of them were private

---

<sup>145</sup> *Chron. Bower*, v, 190-3.

<sup>146</sup> *Ibid*, 191.

<sup>147</sup> Oram, ‘Introduction: An overview of the reign of Alexander II’, 1-49; Penman, ‘Royal piety in thirteenth-century Scotland’, 14; *ESSH*, ii, 400; *Chron. Bower*, iv, 475.

<sup>148</sup> *ESSH*, ii, 469, 488-9.

<sup>149</sup> Oram, ‘Introduction: An overview of the reign of Alexander II’, 43-4.

foundations.<sup>150</sup> Moreover, Alexander issued a lot of acts to religious houses. For examples, of 396 extant acts issued during his reign, 33 acts were issued for Arbroath Abbey, and 32 acts for Melrose Abbey.<sup>151</sup> The former was attractive to Alexander II because it was the abbey his father himself founded to dedicate to St Thomas. In particular, the king issued ten acts for the abbey at the very beginning of his reign, c.1215-6, which might have related to his intention to secure St Thomas's intercessory power during the Anglo-Scottish war of 1215-17.<sup>152</sup> As Fawcett has pointed out, the main building of the abbey church at Arbroath was likely completed by the date of its dedication on 8 May 1233.<sup>153</sup> However, the construction of the abbey presumably still carried on even after 1233. Under this circumstance, it is likely that Alexander II's grants to Arbroath Abbey were partly intended to offer the financial support for the building operation. As William did to Arbroath Abbey, Alexander II favoured Melrose Abbey, where he chose to be buried, as discussed below.

In comparison with those abbeys, Dunfermline Abbey was not successful in drawing the king's attention. Just eight extant acts were issued to the abbey.<sup>154</sup> While previous kings issued acts to Dunfermline Abbey to confirm privileges given by their predecessors shortly after their inaugurations, it was not until August 1227 that Alexander II gave a gift and

---

<sup>150</sup> Probably Trinitarian House in Aberdeen; Ardchattan, Argyll-Valliscaulian (1230, Duncan MacDougall); Beaulieu, Valliscaulian (1230, John Bisset); Possibly Trinitarian at Berwick; Blantyre, Augustinian (1239x1248); Culross, Cistercian (1218, earl of Fife); Deer, Cistercian (1219, earl of Buchan); perhaps Elcho, Cistercian Nuns; Fearn, Premonstratensian (1220s or 1230s, earl of Ross); probably Holywood (Dumfries), Premonstratensian; Inchmahome, Augustinian (1238, earl of Menteith); perhaps Monymusk, Augustinian; Tongland, Premonstratensian (1218, Alan of Galloway) (Norman H. Reid, 'A great prince, and very greedy of this world's honour' in Oram ed., *The Reign of Alexander II*, 50. n. 4; Cowan and Easson, *Medieval Religious Houses: Scotland*, 107-8, 83, 84, 108, 89, 74, 146, 101, 102, 91, 93, 103).

<sup>151</sup> Extrapolated from *Handlist*, i. Other cases are as follows: Scone Abbey (20 acts), Coupar Abbey (14), Coldingham Abbey (15), Newbattle Abbey (18), Glasgow Cathedral (20), Kelso Abbey (11), Dunfermline Abbey (7), Balmerino Abbey (7), Paisley Abbey (6), Holyrood Abbey (8), Cambuskenneth Abbey (5), Inchaffray Abbey (4), Beuly Abbey (4), Culross Abbey (3), Lesmachagow Priory (3), St Andrews Cathedral (3), Lindores Abbey (2), Jedburgh Abbey (2), Kinloss Abbey (2), Mary Priory (2), Knights Hospitaller (2), Dryburgh Abbey (1), Brothers of [leper] Hospital of St. Nicholas at St Andrews (1), and Citeaux Abbey (1).

<sup>152</sup> *Ibid.*, nos. 1, 8, 13, 17, 18, 19, 21, 23, 33, 44; Keith Stringer, 'Kingship, Conflict and State-Making in the Reign of Alexander II: The War of 1215-17 and its Context' in Oram ed., *The Reign of Alexander II, 1214-1249*, 99-156.

<sup>153</sup> Fawcett, 'Arbroath Abbey: A Note on its Architecture and Early Conservation History' in Geoffrey Barrow ed., *The Declaration of Arbroath: History, Significance, Setting* (Edinburgh, 2003), 51.

<sup>154</sup> *Handlist*, i, nos. 116, 117, 149, 150, 230, 236, 293, 389; *Registrum de Dunfermelyn*, nos. 74, 75, 76, 77, 78, 79, 80, 193.

confirmation of grants presented by his predecessors to the abbey.<sup>155</sup> In sharp contrast with that, of 33 extant acts issued for Arbroath Abbey by Alexander II, 16 acts were issued before 1227, and that as to Melrose Abbey, 13 of 32 extant acts were issued before 1227.<sup>156</sup> In particular, Alexander II perhaps intended to promote Arbroath Abbey, in which his father was buried, and to complete the construction of the abbey. In his first act to Dunfermline Abbey issued in August 1227, the king commanded the sheriff of Fife to give the abbey one eighth of royal revenues and fines in his bailiary.<sup>157</sup> In 1231 the king commanded the earl of Fife and his bailies to give the abbey one eighth of fines made by the king for the earldom of Fife.<sup>158</sup>

There is no extant document indicating how much royal revenue and fines in Fife were collected during the reign of Alexander II, thus it is not possible to measure an exact income. Instead it is possible to estimate it from later evidence. According to the *Exchequer Rolls*, of £35 17s. 6d. which the sheriff of Fife collected in 1264, Dunfermline Abbey was granted 102s. 6 d. which was an eighth of the amount of royal income collected by the sheriff. In 1264, likewise, Dunfermline Abbey was given 19s. 7d. from an eighth of the income of the Justiciar.<sup>159</sup> In 1266, the abbey was given 2s. 6d. which was an eighth of the revenue of the Justiciar, 17s. 6d.<sup>160</sup> The *Exchequer Rolls* indicated that generally a tenth or an eighth of the fines or revenues of the court of Justiciary and Sheriff were allotted to the Church. For example, bishops took a tenth of the incomes in the dioceses of Aberdeen, Moray, Ross and Caithness; in Kincardine, they were granted to the bishop of Brechin; in Forfar, to the prior of

---

<sup>155</sup> *Ibid.*, nos. 78, 74; *Handlist*, i, nos. 116-7.

<sup>156</sup> *Ibid.*, nos. 1, 8, 13, 17, 18, 19, 21, 23, 33, 44, 46, 50, 58, 66, 78, 101. For Melrose Abbey see *Ibid.*, nos. 3, 4, 5, 9, 30, 31, 98, 106, 301, 302, 303, 309, 315.

<sup>157</sup> *Registrum de Dunfermelyn*, no. 78.

<sup>158</sup> *Ibid.*, no. 79.

<sup>159</sup> John Stuart, George Burnett eds., *The Exchequer Rolls of Scotland*, 23 vols. (Edinburgh, 1878), i, 4.

<sup>160</sup> *Ibid.*, 31.



Restenneth; in Perth, to the abbot of Scone; in the diocese of Glasgow, an eighth of income went to the bishop of Glasgow.<sup>161</sup>

In addition to grants from royal revenues and fines, the king granted Dunfermline Abbey lands at Dollar in Clackmannan, in exchange for ‘free alms’ from royal lands in Kinghorn and Crail, Fife, and for revenues from the royal kitchen in 1236.<sup>162</sup> The ‘free alms’ from royal manors and the royal kitchen was likely to refer to leftover food distributed to the poor. Apart from royal patronage, the abbey also received lay patronage. In particular, while the king issued only one act to the abbey before 1231, a toft in Leith and a toft in Haddington were given to the abbey by Thomas de Lastalric and David de Lindsey *c.*1228.<sup>163</sup> Moreover, in 1231 Gilbert de Cles paid 10s. annually to the abbey for the land between Cleish and Forest of Outh in Perth and Kinross. In 1234 Constantine Lochor abandoned his claim to Kinglassie in Fife to the abbey.<sup>164</sup> In financial terms, these grants might have contributed to

<sup>161</sup> *Ibid*, lviii.

<sup>162</sup> *Registrum de Dunfermelyn*, no. 75. The concept of ‘free alms’ tenure developed in the eleventh and twelfth centuries to ease the duty of secular service. With ‘free alms tenure, the religious community could use the land to maintain the community and to support its activity, in perpetuity (Benjamin Thompson, ‘Free Alms Tenure in the Twelfth Century’, *Anglo-Norman Studies* 16 (1994), 221-43.

<sup>163</sup> *Registrum de Dunfermelyn*, nos. 188, 191.

<sup>164</sup> *Ibid*, nos. 192, 193, 179. The lay witnesses named on ‘the above-mentioned acts for Dunfermline during the reign of Alexander II’ are as follows:

Lay witnesses to the acts for Dunfermline Abbey (Amanda Beam, John Bradley, Dauvit Broun, John Reuben Davies, Matthew Hammond, Michele Pasin (with others), <i>The People of Medieval Scotland, 1093 - 1314</i> (Glasgow and London, 2012) [hereafter PoMS], Document 1/7/137; 1/7/175; 1/7/261; 3/144/1; 3/179/1; 3/350/20; 3/357/3; 3/497/6 ( <a href="http://db.poms.ac.uk/record/source/1989; 2029; 2125; 4511; 4517; 5377; 5379; 5384">http://db.poms.ac.uk/record/source/1989; 2029; 2125; 4511; 4517; 5377; 5379; 5384</a> accessed on 05/12/2013))	
<i>Registrum de Dunfermelyn</i> (no.)	Lay witnesses
192	John of Hay, knight; David of Lochore, knight; Patrick de Pitglassie; Edmund of Beath; John of Oberville
193	Alan, master (FIF); Andrew Granservise ('great ale'); Constantine of Lochore (II), son of Philip; John of St Andrews, master; Philip of Lochore (brother of Constantine); Richard Orwell, master; William of Mastertown (early 13C); William of Pitliver
179	Michael Scott, son of Malothen; Richard of Dumbarton, master; Simon de Droch; Water of Logie; William of Blair, knight, steward of Fife
75	Patrick, earl of Dunbar; Walter son of Allan, Steward of Scotland; Walter Comyn, earl of Menteith; Walter Olifard, Justiciar of Lothian; Alan Durward; Walter Bisset; Bernard Fraser, sheriff of Stirling
78	William Comyn, earl of Buchan
79	John Maxwell, chamberlain, sheriff of Roxburgh; Walter Stewart, son of Alan
188	None

the building operation at Dunfermline, which was mentioned in a Papal bull of 1231.<sup>165</sup> Additionally, as lay witnesses to Alexander II's acts for Dunfermline demonstrate, these were likely to have association with Dunfermline: the earls of Menteith, Buchan, Dunbar and Angus, and the lords of Luffness (in East Lothian), Fogo (in Berwickshire), Kilbride (in Lanarkshire), Errol (in Perth and Kinross).<sup>166</sup>

There is no extant document demonstrating how often the king stopped or stayed at Dunfermline. However, the place-dates of royal acts enable us to approximate some of the king's stays there. As far as the extant place-dates of acts are concerned, of 396 extant acts issued by the king a considerable number of acts were issued in royal burghs: 58 acts were issued in Edinburgh, 28 in Stirling, 23 in Forfar, 18 in Scone, 16 in Selkirk, 12 in Roxburgh, 8 in Perth. On the other hand, only two acts were issued in Dunfermline on 12 February 1215x1221 and 16 April 1249 (close to that year's campaign).<sup>167</sup> Therefore, it might be said that Alexander II did not frequently visit Dunfermline. In addition, the lands the king granted to the abbey or confirmed in the abbey's ownership were centred on the regions of Fifeshire, East Lothian and Clackmannanshire,<sup>168</sup> which were close to the abbey in geographical terms. The distribution of the lands indicates that the influence of the abbey strengthened locally.

191	Henry of Stirling, son of earl of David; Henry of Halliburton, knight; Gerard Lindsay, son of David (I), knight
-----	---

<sup>165</sup> *Registrum de Dunfermelyn*, no. 130.

<sup>166</sup> For the earls see *Ibid*, nos. 74, 75, 76; 74, 78; 75; 80. For the lords see *Ibid*, nos. 74; 77; 80; 80. There were also some other lesser known laity such as Gerard Lindsay, son of David and knight; Henry of Halliburton, knight; Henry of Stirling, son of earl David of Huntingdon; Walter Bisset; William of Blair, knight and steward of Fife (*Ibid*, nos. 191; 191; 191; 75, 77; 179, and note 163 above mentioned).

<sup>167</sup> Extrapolated from *Handlist*, i. The number of charters issued to the abbeys was not proportional to the number of charter issued in some places. For example, as far as charters recorded, of 33 charters to Arbroath Abbey issued in Forfar (7), Perth (4), Edinburgh (2), Kintore (1), Fyvie (1), Stirling (1), Barry (2), Kincardine (1), Lister (1), St Andrews (1), Newbattle (1), Inverkeithing (1), Cupar (1) and Arbroath (1). As to Melrose Abbey, Edinburgh (8), Selkirk (5), Roxburgh (1), Belford[?] (1), Berwick (1), Traquair (1), Ancrum (3), Jedburgh (1), Holyrood (1) and Melrose (1). As to Dunfermline, Clackmannan (1), Scone (3), Berwick (1), Stirling (2). For Dunfermline see *Ibid*, nos. 11, 297. These are witnesses to the acts for Dunfermline: Alexander, son of William, sheriff of Stirling; Richard, son of Michael of Peaston; Robert Sinclair; Walter Lindsay (III), son of William (II); William Comyn, earl of Buchan; William del Bois, chancellor (PoMS, Document 1/7/5 (<http://db.poms.ac.uk/record/source/1826/> accessed on 18/12/2013)). Robert de Keldeleth, abbot of Dunfermline; Robert Menzies; William Oliphant (*Ibid*, Document 1/7/340 (<http://db.poms.ac.uk/record/source/1813/> accessed on 18/12/2013)).

<sup>168</sup> *Registrum de Dunfermelyn*, nos. 75-7.

During the reign of Alexander II, the most successful religious house was Melrose Abbey, which was founded by King David in 1136, and the monks of which were originally from Rievaulx in Yorkshire,<sup>169</sup> and which founded its own five daughter houses at Newbattle, Holm Cultram, Kinloss, Coupar Angus and Balmerino.<sup>170</sup> It seems that Alexander II considered religious patronage and personal piety an effective way to secure political supporters, and that he made use of his influence over the church to gain additional political authority. For him, Melrose Abbey was one of the crucial houses to accomplish this purpose. For example, he appointed Gilbert, a monk from Melrose, to the post of bishop in the politically sensitive area of Galloway in 1235. Gilbert was commissioned to help settle a potentially dangerous rebellion in Galloway.<sup>171</sup> Moreover, when the abbots of Dundrennan and Glenluce in Galloway were deposed, Alexander appointed monks from Melrose to the posts.<sup>172</sup> The replacement of potentially strategic clerics with Melrose monks indicates a close association between the crown and the abbey. Above all, the climax of their relationship was reached at Alexander's burial at the abbey at his request.<sup>173</sup>

---

<sup>169</sup> Fawcett and Oram, *Melrose Abbey*, 20.

<sup>170</sup> David Ditchburn, 'Saints and Silver: Scotland and Europe in the age of Alexander II' in Oram ed., *The Reign of Alexander II*, 180; Cowan and Eason, *Medieval Religious Houses: Scotland*, 72-9; Fawcett and Oram, *Melrose Abbey*, 22-8. The place-dates of royal acts indicate that Alexander II had given a gift to Melrose Abbey on 21 February 1236 and had been at Melrose on 24 February 1236 (*Handlist*, i, nos. 210-11), which might be relevant to the 100<sup>th</sup> anniversary of the abbey's foundation.

<sup>171</sup> Oram, 'Introduction: An overview of the reign of Alexander II', 44; Fawcett and Oram, *Melrose Abbey*, 30.

<sup>172</sup> *Ibid*, 31.

<sup>173</sup> *The chronicle of Melrose: from the Cottonian manuscript, Faustina B. IX in the British Museum: a complete and full-size facsimile in colotype*, Alan Orr Anderson and Marjorie Ogilvie Anderson eds. (London, 1936), 108. Why Alexander II chose Melrose to be buried can be examined at two levels. Firstly, Melrose was the centre of South-eastern Scotland, Northumbria, Galloway and Cumbria and beyond in terms of spirit, politics and economic dimension. In particular, in the 1240s Melrose was chosen for interment by important laymen of Northumbria (Jamroziak, 'Making friends beyond the grave: Melrose Abbey and its lay burials in the thirteenth century', 323-36). In other words, Alexander's political intention to take northern England and control over the unstable border regions in Scotland might have motivated him to develop a close relationship with Melrose Abbey, which could play an important role in governing the region on behalf of the crown, by being interred there. Secondly, his personal piety presumably led him to be buried there. Just as his father, William, dedicated himself to Arbroath, so he did to Melrose. As Michael Penman has pointed out, Alexander II 'may have felt a genuine debt of penance to Melrose's Waltheof for his own breach of oaths made in 1216 and the destruction of Melrose's daughter churches and the papal excommunication which had ensued (Penman, 'Royal piety in thirteenth-century Scotland', 18).'

As mentioned above, it is certain that Alexander II was less interested in Dunfermline Abbey than Melrose. However, it is seen that the 1230s and in particular, the 1240s was the turning point to divert Alexander II's attention to Dunfermline. Alexander may have realized that a royal saint would promote his political authority, and a royal cult could be exploited for a propaganda campaign to boost national pride when the monarch and his kingdom were endangered by enemies.<sup>174</sup> Political tension with internal royal challengers from the west Highlands, Hebrides and Galloway, and the MacWilliams in the 1220s and 1230s<sup>175</sup> would have encouraged him to promote a royal cult in order to boost royal authority, by trying to secure the canonisation of St Margaret. Apart from internal political challenges, Scotland clashed with England in 1237 and 1244.<sup>176</sup> In fact, the two kingdoms kept the peace until the last stage of the life of Queen Joan, who was a daughter of English King John and a sister of English King Henry III (1216-1272) and died in 1238 without children.<sup>177</sup> This external conflict would also have prompted Alexander to promote the royal cult. In addition to the conflict with Henry III, the English king's favour to Westminster Abbey, spending around £41,000 on the reconstruction of the abbey from the 1230s, the most generous act of architectural patronage by a single person during the Middle Ages,<sup>178</sup> was likely to influence Alexander II's encouragement of his own royal cult. The canonisation process of St Edmund

---

<sup>174</sup> Theilmann, 'Political Canonization and Political Symbolism in Medieval England', 242-3.

<sup>175</sup> Oram, *Alexander II, King of Scots 1214-1249*, 71-107; Oram, 'Introduction: An Overview of the Reign of Alexander II', 35-43.

<sup>176</sup> *Ibid.*, 15-9; Duncan, *Scotland*, 532-3, 535-7.

<sup>177</sup> *Ibid.*, 534; *ESSH*, ii, 510-12.

<sup>178</sup> R. Allen Brown, H. M. Colvin and A. J. Taylor, *The History of the King's Works: The Middle Ages*, 2 vols (London, 1963), I, 155-7. Another building project which can be compared with Westminster Abbey was Louis IX's building of Sainte-Chapelle (at the cost of roughly £10,000) (Wilson, 'Calling the Tune? The Involvement of King Henry III in the Design of the Abbey Church at Westminster', 84, n. 2). For the relationship between Westminster and English royal families prior to Henry III see Barbara Harvey, *Westminster Abbey and its Estates in the Middle Ages* (Oxford, 1977), ch. 1. 'The foundation of Westminster Abbey', 20-5; Emma Mason, 'Westminster Abbey and the Monarchy between the Reigns of William and John 1066-1216' in *Westminster Abbey and its people c.1050 - c.1216* (Woodbridge, 1996), 269-87; Emma Mason, 'The Site of King-Making and Consecration': Westminster Abbey and the Crown in the Eleventh and Twelfth Centuries' in *Ibid.*, 288-305; Mark Duffy, *Royal Tombs of Medieval England* (Stroud, 2003), 17-8; Scholz, 'The canonization of Edward the Confessor', 38-60.

of Canterbury undertaken from 1244<sup>179</sup> would also have encouraged Alexander II to request the pope to launch the process of St Margaret's canonisation. Apart from political concerns, Alexander II's need of an heir after his second marriage with Mary de Coucy in 1239 might have motivated Alexander II to divert his attention to Dunfermline, hoping for the holy power of St Margaret's 'sark', although their son called Alexander was born at Roxburgh on 4 September 1241.<sup>180</sup> Moreover, the king's visit to Westminster via Canterbury in 1223<sup>181</sup> perhaps partly influenced Alexander II's later motivation to develop Dunfermline as a royal cult centre.

The career of Robert de Keldeth, the abbot of Dunfermline (1240-52)<sup>182</sup> may also have been crucial to the change in Alexander's attitude toward Dunfermline in the 1240s. Abbot Robert was one of the most successful abbots of Dunfermline in terms of his relationship with the pope. On 3 May 1245 Pope Innocent IV allowed the abbot to use the mitre and the ring at the request of the king.<sup>183</sup> Given that some prelates by concession and bishops were allowed to wear the mitre and the ring for celebrating ceremonies, if Dunfermline became a coronation church, they would have been presumably used for the coronation ceremony. On 5 May 1245, Innocent IV had commanded the dean and treasurer of Glasgow to give indulgence to the abbot and monks of Dunfermline, so that they should not be brought to Rome for litigation reasons.<sup>184</sup> In addition, on 27 April 1245, Innocent IV

---

<sup>179</sup> Innocent IV commanded that the enquiry of St Edmund held in 1244 should be done again (Innocent IV, *Attendentis quod*, April or May 1245, Martène and Durand eds., *Thesaurus Novus Anecdotorum*, III, col. 1844 (Potthast, 1645).

<sup>180</sup> *Chron. Bower*, v, 167. As the place-dates of Alexander II's acts demonstrate, the king stayed at Roxburgh on 31 August 1241 (*Handlist*, i, no. 251), which leads us to speculate that he had perhaps given thanks to St Waltheof of Melrose nearby Roxburgh for the birth of his son.

<sup>181</sup> *Chron. Bower*, v, 117.

<sup>182</sup> He succeeded Geoffrey III (1238-1240), whose previous abbot was William II (1223x1226-1238) (D.E.R. Watt and N.F. Shead eds., *The Heads of Religious Houses in Scotland from the 12th to the 16th Centuries* (Edinburgh, 2001), 68; *Registrum de Dunfermelyn*, xi-xiii).

<sup>183</sup> *Ibid*, no. 279.

<sup>184</sup> *Ibid*, nos. 280, 600.

announced that Dunfermline Abbey should be defended from unjust excommunication.<sup>185</sup> The request of the king for allowing Robert de Keldelth to use the mitre and the ring demonstrates the close relationship between the king and the abbot. Their association mirrored Robert's appointment as royal chancellor in 1249 after Alexander III was inaugurated.<sup>186</sup> Moreover, the canonisation of St Margaret in 1249 and the translation of the saint's remains into a new shrine in 1250-1 were held under the control of Abbot Robert.

Concerning the canonisation of St Margaret, Alexander II requested Pope Innocent IV to launch a process for the canonisation of Queen Margaret in 1245. Under the supervision of H., cardinal priest of St. Sabina, the examination of the life and miracles of Margaret was conducted. On 16 September 1249 the pope declared St Margaret's canonisation.<sup>187</sup> It took only three years to obtain a decree of St Margaret's canonisation from the pope. It seems that not only the abbot of Dunfermline, Robert de Keldelth's relationship with the pope but also his additional effort might have made the progress easier.<sup>188</sup> In addition, the Scots' contribution to the Crusade presumably helped obtain the canonisation of the saint within a relatively short length of time. In 1247 the pope instructed the bishop of Dunblane to collect a twentieth of incomes from the Scottish church for the Crusade, and for conveying 3,000 *livres tournois* to the crusaders, and the pope ordered other Scottish churchmen to cooperate with the bishop.<sup>189</sup> The Scots might have met the pope's requirement. In return, the pope

---

<sup>185</sup> The bull noticed as follows: 'We, having given heed to your devout prayers, by authority of these presents, Grant you an indulgence, if at any time you or your servants happen to hold intercourse with such excommunicated persons, that ye shall on no account be bound with the cord of the greater excommunication, provided ye be no partakers with the guilty in their crime (*Ibid*, no. 599).'

<sup>186</sup> *ESSH*, ii, 564.

<sup>187</sup> *Registrum de Dunfermelyn*, no. 290.

<sup>188</sup> Abbot Robert worked for the pope as a papal chaplain (*ESSH*, ii, 563). Abbot Robert was succeeded by his Prior John (1252-1256). After he died in 1256, the cellar Matthew was succeeded. In 1267 Simon (1267-1275) replaced Matthew. In 1275 Simon was deposed, Radulf de Greenlaw (1275-1296) became abbot (*ESSH*, ii, 518; *Chron. Bower*, v, 303, 319, 407; *The Heads of Religious Houses in Scotland from the 12th to the 16th Centuries*, 68).

<sup>189</sup> *Vetera Monumeta Hibernorum et Scotorum Historiam Illustrantia*, ed. A. Theiner (Rome, 1864) [hereafter Theiner, *Vet. Mon.*], 48; *Calendar of Entries in the Papal Registers Relating to Great Britain and Ireland: Papal Letters*, eds. W.H. Bliss and others, i, 237. During the 1250s, the request for taxation incurred dispute between the Scottish church and English king Henry III, who announced his plan to lead a crusade and collected taxation from the English church and requested it of the Scottish church, because the Scottish church was afraid

probably responded quickly to the request for the canonisation of St Margaret. Moreover, as discussed in Chapter one, the Dunfermline compilation, which was put together during the reign of Alexander III (1249-86) to demonstrate the Anglo-Saxon ancestry of the Scottish kings in order to convince the pope, who did not want to be against the English king,<sup>190</sup> was perhaps intended to obtain the pope's permission for the rite of coronation as well as the canonisation process.

In summary, in the early part of his reign Alexander II was less interested in Dunfermline Abbey than in such abbeys as Arbroath and Melrose. However, in the 1230s and 1240s the internal and external political circumstances and English King Henry III's reconstruction of Westminster and his promotion of the English royal cult of the Confessor presumably led Alexander II to recognize the significance of sacred kingship and royal cult, which is likely to contribute to raising Alexander II's awareness of the value of Dunfermline as a royal cult centre. Moreover, the demand for St Margaret's sacred power to secure his heir and the influence of Abbot Robert of Dunfermline may also have made the king draw his attention to Dunfermline.

---

that the financial demand would be accompanied by English control (Michael Brown, *The Wars of Scotland 1214-1371* (Edinburgh, 2004), 125-6).

<sup>190</sup> Taylor, 'Historical writing in twelfth-and thirteenth-century Scotland: the Dunfermline compilation', 228-52.

## **(6) Alexander III (1249 - 86)**

Innocent IV allowed Queen Margaret to be canonised on 16 September 1249, a few months after the inauguration of Alexander III at the age of seven held at Scone on 13 July 1249. On 21 September the pope granted an indulgence of 40 days to penitents who visited Dunfermline Abbey as the shrine of St Margaret.<sup>191</sup> The procedure of canonisation incurred expenditure. As Vauchez has pointed out, an English document, the register of John de Droghensford, Bishop of Wells and Bath from 1310-30, indicates that the expenses relating to an appeal for an investigation of a canonisation were very costly. The commissioners dispatched by the pope to investigate the life and miracles of a candidate were expected to receive hospitality during their stay. The expense was necessary to summon witnesses and employ the notaries who recorded and copied the testimonies. The following curial stage also needed money, because it was necessary to take the procurator's instruction in order to track the case, to give many gifts to influential people pertaining to the process and to keep the records safely. At the final stage of the process of the canonisation, the costs of the banquets and festivities which followed the liturgical ceremony were required.<sup>192</sup> The cost of the final stage of the process of St Margaret's canonisation can be speculated by using other cases which happened a century later: in the case of St Yves (1346-7), 3,000 florins (£300) was paid for the costs of the banquets and festival; St Bridget of Sweden (1375-91), 5,000 ducats (£500); St Sebald, 5,000 florins (£500) in 1429; St Osmund (1442-59), £731 13s.<sup>193</sup>

Therefore, only significant groups such as religious houses or monarchs could have afforded the expense. If they did not have enough money for the expense of the canonisation process, they needed to raise money to cover the cost. In 1311 King Robert of Naples provided 400 gold florins to the Franciscan William of Saint-Marcel '*pro expeditione inquisitionis facte de miraculis clare memorie domini Ludovici episcopi Tolosani fratris*

---

<sup>191</sup> ESSH, ii, 87; *Registrum de Dunfermelyn*, nos. 290-1.

<sup>192</sup> Vauchez, *Sainthood in the later Middle Ages*, 64-5.

<sup>193</sup> *Ibid*, 66.



*nostril*.<sup>194</sup> In 1327, the bishop of Bath and Wells decided to levy a tenth on the incomes of benefices in his diocese to prepare for the expenditure of the process of canonisation of his predecessor, William March.<sup>195</sup>

Turning to Queen Margaret, as mentioned above, the procedure of Queen Margaret's canonisation was launched at the request of Alexander II and Abbot Robert in 1245. This means that Alexander II may have taken responsibility for some part of the finance to carry out the process. Basically, given the economic prosperity during the reign of Alexander II,<sup>196</sup> the king could afford to pay for the expense regarding the canonisation process of St Margaret. The king may have given Dunfermline Abbey some gifts which could have been used to cover the cost, and although no document concerning the procedure survives, it is possible to speculate about Alexander II's financial support of the canonisation process of St Margaret. The grants Alexander II gave the abbey of the forest of Dollar in 1236 and some land at Dollar in 1237<sup>197</sup> may have been connected with the king's payment for the process of St Margaret's canonisation. Above all, the indulgence of 40 days, which on 21 September 1249 Pope Innocent IV granted to penitents who visited Dunfermline, was probably one of the means to cover the expense for the canonisation and the translation.<sup>198</sup> It was not rare that an indulgence was used as a way to raise funds for specific purposes. For instance, as Suzanne Lewis suggests, the indulgences which Pope Innocent IV granted 'to contributors from the dioceses of London, Lincoln and Winchester' on 26 July 1245 was probably one of the methods to raise funds for the reconstruction of Westminster Abbey. Innocent VI and

---

<sup>194</sup> *Ibid*, 67.

<sup>195</sup> *Ibid*, 64.

<sup>196</sup> Ditchburn, 'Saints and Silver: Scotland and Europe in the Age of Alexander II', 203; Oram, 'Introduction: An overview of the reign of Alexander II', 46.

<sup>197</sup> Witnesses are as follows: Alan Durward; Bernard Fraser sheriff of Stirling; Patrick (II) earl of Dunbar; Walter Bisset (13C); Walter Comyn earl of Menteith; Walter Oliphant justiciar of Lothian (son of Walter); Walter Stewart son of Alan (*Registrum de Dunfermelyn*, no. 75; PoMS, Document 1/7/261 (<http://db.poms.ac.uk/record/source/2125/> accessed 05/12/2013)). Walter Comyn earl of Menteith; Walter Oliphant justiciar of Lothian (son of Walter); Walter Stewart son of Alan (*Registrum de Dunfermelyn*, no. 76; PoMS, Document 1/7/267 (<http://db.poms.ac.uk/record/source/2131/> accessed on 05/12/2013)).

<sup>198</sup> *Registrum de Dunfermelyn*, nos. 290-1; *ESSH*, ii, 87.

Urban V also granted indulgences to raise funds for York's rebuilding project in the 1360s.<sup>199</sup> From these facts, it can be concluded that an indulgence granted at Dunfermline largely contributed to fund-raising to cover the cost of canonisation. The tactical choice of the date of the saint's translation on 19 June just before Mid-Summer alongside summer feasts of other saints as mentioned in Chapter One, and which split the year in two alongside the date of St Margaret's death on 16 November was also intended to promote the cult of the saint, and provide financial help to the abbey.

Shortly after St Margaret was listed in the Catalogue of the Saints, it is known that the translation of St Margaret's remains took place, according to Bower, on 19 June 1250. The minor King Alexander III, seven bishops out of the bishoprics of Glasgow, St Andrews, Dunblane, Dunkeld, Brechin, Aberdeen, Moray, Ross and Caithness,<sup>200</sup> seven earls - there was no mention who the seven earls were - and abbots were present there, and bishop Bernham of St Andrews presided over the event.<sup>201</sup> Bower said that the relics of St Margaret were translated from 'the outer church', that is, 'the stone monument in which they had rested for the space of many years' into 'a pinewood shrine, adorned with gold and jewels', namely, 'the choir, above the greater altar'.<sup>202</sup> However, Bower, writing in the 1440s and with access to Dunfermline's library and records and institutional memory, seems to have conflated the description and memories of the 1180 translation and that of 1250. Regardless of whatever his intentions were, given the translation of 1180, it should be said that the relics were moved from 'on the north side of the altar', to which the remains had been translated in 1180, to 'the east-end chapel' in 1250. As discussed above, a miracle, which had been said to happen in the 1250 translation by Bower might have occurred in the 1180 translation. However, it is

---

<sup>199</sup> Suzanne Lewis, 'Henry III and the Gothic Rebuilding of Westminster Abbey: The Problematic of Context', 162-3; Swanson, *Indulgences in Late Medieval England*, 63. For indulgences for specific purposes see *Ibid*, ch. 2. 'Pardons for every occasion...', 23-76.

<sup>200</sup> Duncan, *Scotland*, 262.

<sup>201</sup> *Registrum de Dunfermelyn*, no. 348; *Chron. Bower*, v, 297, 442.

<sup>202</sup> *Ibid*, 296-9.

also possible that the miracle perhaps happened again in the 1250 translation so that Bower recorded it. If that is the case, St Margaret's body refused to be moved without being accompanied by her husband's remains on two occasions, the 1180 translation and the 1250 translation.

Prior to Bower, John of Fordun, whose work was consulted/continued by Bower and collated earlier thirteenth century St Andrews sources, stated that the translation occurred 'in the second year of Alexander III's reign, on 19 June 1250', Trinity Sunday of the year.<sup>203</sup> Concerning the date of the translation, the phrase, 'in the second year of Alexander III's reign', should be highlighted. That is, the king was inaugurated on 13 July 1249,<sup>204</sup> and thus the 19 June 1250 was still the first year of his reign, with the second year commencing on 13 July 1250. Therefore, it seems likely that the translation took place in June 1251 but not in 1250. Furthermore, in 1251 Trinity Sunday and Easter Day fell on the same dates as they had done in 1150.<sup>205</sup> That is, Trinity Sunday was celebrated on 11 June and Easter Day on 16 April in 1150 and 1251. If the assumption that the translation would have been carried out in 1251 rather than 1250 is accepted, then the post-canonisation translation of Margaret took place on the full hundredth year anniversary of the consecration of the abbey (Trinity Sunday, 11 June 1150).<sup>206</sup> Another possibility can also be suggested: the translation was celebrated for a full year from 1250 to 1251. In other words, the translation took place on the 19 June 1250 as the chroniclers recorded, and it was celebrated for a full year until, as John of Fordun specified, the second year of Alexander III's reign, that is, 11 June 1251, with 19 June following at the close of the Octave of the consecration Trinity date.

---

<sup>203</sup> *Chron. Fordun*, 295; *John of Fordun's Chronicle of the Scottish nation*, 290; Cheney, *Handbook of Dates*, 94-5.

<sup>204</sup> *Chron. Bower*, v, 291.

<sup>205</sup> Cheney, *Handbook of Dates*, 134-5.

<sup>206</sup> *The Charters of King David I*, 136.

In the Middle Ages, the major reasons for the translation of relics were to renovate a shrine and promote a church's reputation.<sup>207</sup> In this vein, along with the canonisation of St Margaret, the translation of 1250/1 would have aimed to promote the cult of St Margaret. Concerning the architecture at Dunfermline Abbey, the eastward extension for St Margaret's feretory was the most significant building operation in the thirteenth century. However, other works were perhaps carried out prior to the extension. Pope Gregory IX referred to the 'enlarged' and 'nobler structure' of the abbey in a bull of 1231.<sup>208</sup> In spite of this operation, on 18 August 1249 Pope Innocent IV declared that since Dunfermline Abbey's 'ancient walls remained for the greater part in their previous state', it was not necessary to re-consecrate the church,<sup>209</sup> and on 19 June 1250/1 St Margaret's new feretory chapel, a completion of which would have been required for years, was consecrated.

Since no extant document records the expense of the translation, the total cost is unknown. However, from some documents concerning other saints' translations, it is possible to approximate the expense of St Margaret's translation. In 1276, Bishop Stephen of Chichester spent over £1,000 for the translation of St Richard.<sup>210</sup> Henry III provided £1,210 for making images of SS Edmund and Peter, six kings, five angels, a Virgin and Child and a Majesty on the shrine of St Edward;<sup>211</sup> he also paid 250 marks for three golden images on the shrine of Thomas Becket in 1243;<sup>212</sup> he spent £2,555 4s. 8d. for the shrine of St Edward in 1267 when political strain forced him to spend much money for the saint.<sup>213</sup> Concerning the cost for the 1220 translation of St Thomas, although the total cost of the translation is not

---

<sup>207</sup> Nilson, *Cathedral Shrines of Medieval England*, 19. Translations sometimes accompanied consecration of a new bishop. Master Richard de Inverkeithing was appointed as a bishop of Dunkeld before 3 December 1250, and he was not consecrated until 3 August x 20 October 1251 (*Chron. Bower*, v. 299, 442; D.E.R. Watt, *A Biographical Dictionary of Scottish Graduates to A.D. 1410* (Oxford, 1977), 280-2).

<sup>208</sup> *Registrum de Dunfermelyn*, no. 130.

<sup>209</sup> *ESSH*, ii, 87; *Registrum de Dunfermelyn*, no. 288.

<sup>210</sup> M.E.C. Walcott, 'The Bishops of Chichester from Stigand to Sherbourne', *Sussex Archaeological Collections*, vol. 28 (1878), 35.

<sup>211</sup> H.C.M. Lyte ed., *Calendar of Patent rolls, 1266-1272* (London, 1893), 139; J. Perkins, *Westminster Abbey: its worship and its ornaments*, vol. ii (London, 1938), 39.

<sup>212</sup> *Calendar of the Liberate Rolls*, vol. ii (London, 1916), 196.

<sup>213</sup> *Calendar of Patent rolls, 1266-1272*, 52, 64-5, 135-40.

known, it is certain that exceptionally heavy expense were incurred: the cellarer alone was allotted £1,154 in 1220, in contrast to £442 in 1219.<sup>214</sup> In sum, although the cost of translation varied according to the scale and splendour of the new shrine, a major translation cost approximately £1,000-2,000,<sup>215</sup> and much more if major building works were needed.

Bishops could be involved in the translation by granting indulgences as well as providing financial support.<sup>216</sup> However, they did not expect to earn profits from their patronage, because the community had benefits immediately from the shrine and received offerings from pilgrims. Thus, bishops' sponsorships were motivated by their piety but not by their practical interest. In general, the local clerics organized the translation. On rare occasions such as the 1148 translation of St Erkenwald, the expenses were paid by the poor. Kings were involved in exceptional cases like Alexander I's association with the translation of St Cuthbert and Henry III's with that of Edward the Confessor.<sup>217</sup> Since St Margaret was a royal saint, and the process of canonisation was launched at the request of Alexander II, there is no doubt that Alexander III's court supported St Margaret's canonisation and translation. In this point, the 1250/1 translation was obviously different from the 1180 translation because the latter was launched by the initiative of the monks of Dunfermline and carried out by them without the monarch's support. The sponsorship of Alexander III's court of both events - the canonization and the translation - might have been recorded by the monks, even if there is no extant document regarding them.

However, acts issued to Dunfermline Abbey allow us to speculate about Alexander III's patronage concerning both projects. The king was inclined to release the abbey from its liability, which would have been owed to carry out the canonisation and the translation. In

---

<sup>214</sup> Richard Eales, 'The political setting of the Becket translation of 1220' in Diana Wood ed., *Martyrs and Martyrologies* (Oxford, 1993), 138.

<sup>215</sup> Nilson, *Cathedral Shrines of Medieval England*, 21.

<sup>216</sup> *Ibid.*, 22; Swanson, *Indulgences in Late Medieval England*, 27-9.

<sup>217</sup> Nilson, *Cathedral Shrines of Medieval England*, 22.

1255 Alexander III announced Dunfermline Abbey to be free from the pouding system,<sup>218</sup> by which ‘the movables in the debtor’s own possessions are made available for payment; the creditors are able to place the person of the debtor until the debt is paid, or until certain special provisions of the law interfere between them.’<sup>219</sup> By this privilege, part of the cost of the canonisation and the translation could have been covered. In 1255 the king also commanded Alexander Comyn earl of Buchan, Justiciar of Scotland, to inquire ‘whether the abbey owed suit to the Sheriff court of Perth for lands of Forduin and others’; Alexander III gave quitclaim to the abbey ‘from rendering suit to the Sheriff court of Perth’ concerning the case.<sup>220</sup> In addition, some part of the dowry of Alexander III’s Queen, Margaret of England at the cost of 5,000 marks of silver<sup>221</sup> might have flowed to Dunfermline Abbey to support its projects. This suggestion is possible, given that Abbot Robert of Dunfermline was Chancellor of Scotland until 1252.<sup>222</sup>

Along with those, Alexander III issued just one act at Dunfermline on 1 December 1279.<sup>223</sup> He issued seven acts to Dunfermline, the number of which placed that house at the top among the religious communities receiving grants from the king. Alexander III gave confirmations of the grants presented by his predecessor and granted the gifts to Dunfermline: in 1253 the king confirmed Emma’s - daughter and heir of late Gilbert de Smeaton - renunciation of the land of Smeaton to the abbey in 1253; in 1254 the king granted to the monks of the abbey the privilege that ‘no one may take pouds of them or the men dwelling on their land of Dunduff (Fife)...’; in 1277 the king confirmed the grants given by his predecessors; in 1277 the king also confirmed the grant of the land of Dollar at Clackmannan,

---

<sup>218</sup> *Registrum de Dunfermelyn*, no. 84.

<sup>219</sup> Robert Campbell, *The law and practice of citation and diligence: on the basis of the late Mr Darling’s book* (Edinburgh, 1862), 225.

<sup>220</sup> *Registrum de Dunfermelyn*, no. 85; *RRS*, iv, nos. 186-7.

<sup>221</sup> *ESSH*, ii, 570; *Chron. Bower*, v, 301.

<sup>222</sup> *ESSH*, ii, 564; Tait, James, “Kenleith, Robert (d.1273)”, *ODNB*, <http://www.oxforddnb.com/view/article/15281>.

<sup>223</sup> *RRS*, iv, 128.

which was given by his father, Alexander II;<sup>224</sup> the king provided the monks of Dunfermline with a protection of its possessions, and granted that ‘no one may take poinds from them or their men for any debt, pledge or forfeiture.’<sup>225</sup> Alexander III also gave confirmation to Dunfermline Abbey of the grants given by the nobles. In 1277 the king confirmed to the abbey the grant that ‘Malcolm de Moravia, knight, made them of the land of Wester Beath (Fife), which he held heritably of Alexander de Moravia, knight.’<sup>226</sup> In 1278 the king also confirmed to the abbey the grant of ‘the moiety of the land of Beath Waldeve (Fife) that was formerly held of him by John de Strachan, son and heir of the late Ralph de Strachan, knight.’<sup>227</sup> Even though these grants were made over twenty years after the two significant

<sup>224</sup> *Ibid*, nos. 18, 20, 102, 103; *Registrum de Dunfermelyn*, nos. 82, 84, 81, 88.

<sup>225</sup> *RRS*, iv, no. 77.

<sup>226</sup> *Ibid*, no. 104; *Registrum de Dunfermelyn*, no. 89.

<sup>227</sup> *Ibid*, no. 87; *RRS*, iv, no. 115. The lay witnesses named on ‘the above-mentioned acts for Dunfermline during the reign of Alexander III’ are as follows:

Lay witnesses to the acts for Dunfermline Abbey during the reign of Alexander III	
<i>RRS</i> , iv, no. 18; <i>Registrum de Dunfermelyn</i> , no. 82	Walter Comyn, earl of Menteith; Alexander Comyn, earl of Buchan; William, earl of Mar; Alexander Stewart of Scotland; Robert de Ross; Nicholas de Soules; John le Blund; John Saluain
20; 84	Walter Comyn, earl of Menteith; Alexander Comyn, earl of Buchan; Robert de Ross
102; 81	William Fraser the chancellor; David of Lochore, knight; John of Lamberton, knight; Henry of Dundemore, knight; William of Bisset, knight; Thomas of Clenhill, knight; Edward of Pitglassie
103; 88	David of Lochore, knight; John of Lamberton, knight; Henry of Dundemore, knight; William of Bisset, knight; Thomas of Clenhill, knight
104; 89	David of Lochore (Fife; knight; sheriff of Fife); John of Lamberton (knight; sheriff of Stirling in 1263); Henry of Dundemore (knight); William of Bisset (knight; sheriff of Stirling); Thomas of Clenhill (knight) (PoMS, Document 1/8/100 ( <a href="http://db.poms.ac.uk/record/source/983/">http://db.poms.ac.uk/record/source/983/</a> accessed on 05/12/2013)).
115; 87	Alexander Comyn earl of Buchan; Patrick III earl of Dunbar; Robert earl of Carrick; William of Soules (knight); David of Lochore (knight; sheriff of Fife); William Comyn lord of Kilbride; Simon Fraser (knight); William of St Clair (knight); Patrick Graham (knight) (PoMS, Document 1/8/111 ( <a href="http://db.poms.ac.uk/record/source/984/">http://db.poms.ac.uk/record/source/984/</a> accessed on 05/12/2013)).

ceremonies, the canonisation of 1249 and the translation of 1250/1, such support probably related to the two events with building work still underway. Above all, of Alexander III's grants to the abbey, his generosity to release the abbey from debt would have been a significant way to support the expenditure of the canonisation and the translation.

In addition to the patronage of the crown, that Malcolm earl of Fife did homage to Robert de Kaledelth abbot of Dunfermline for the lands of Cluny on the day of St Margaret's translation in 1250/1<sup>228</sup> - which was perhaps partly derived from the earl's intention to secure indulgence, although no record for indulgence on the translation remained - and the grants given by nobles which were confirmed by Alexander III, as mentioned above, suggest the possibility of the engagement of the nobles in the translation of St Margaret in financial terms. Looking at lay witnesses to Alexander III's acts for Dunfermline could also make it possible to speculate which nobles had association with Dunfermline Abbey. The relatively crucial lay witnesses are as follows: earls of Buchan, Menteith, Mar, Dunbar and Carrick; and the lords of Kilbride (in Lanarkshire) and Badenoch.<sup>229</sup>

As far as the number of extant royal acts is concerned, it is not until the late 1270s that Dunfermline Abbey drew Alexander III's attention back. With the exception of the act issued in 1271, half of all extant acts were issued before 1255 and the rest of them after 1277. This pattern indicates that the miracle of Largs in 1263 attributed to St Margaret<sup>230</sup> would not have affected Alexander III's attitude to Dunfermline. Instead, the miracle might be considered as Sir John of Wemyss' personal experience - Wemyss was located c.27km away from Dunfermline to the east. The pattern showing the issue of acts presumably related to political

---

*RRS*, iv, no. 77

John Comyn, lord of Badenoch, John of Fenton, knight and William Sinclair

<sup>228</sup> *Registrum de Dunfermelyn*, no. 348.

<sup>229</sup> *RRS*, iv, nos. 18, 20, 115; 18, 20; 18; 115; 115; 115; 77.

<sup>230</sup> *Miracula*, 87-9.



circumstance. That is, a border dispute arising between Alexander III and Edward in 1277<sup>231</sup> probably led Alexander III to seek spiritual and moral support from St Margaret and his predecessor kings, in consequence, his attention returned to Dunfermline. Dunfermline Abbey was more appealing to his first wife, Margaret (1240-1275), who was a daughter of Henry III and a sister of Edward I, and buried at Dunfermline in 1275.<sup>232</sup> As Steve Boardman has pointed out, Queen Margaret could trace her ancestry back to the Saxon royal dynasty, in particular, Edward the Confessor (c.1003-66). Given that St Margaret was a member of the Saxon dynasty, Henry I's marriage to Matilda, daughter of Malcolm III and St. Margaret, could connect the Anglo-Norman Kingship with the Saxon dynasty, that is, 'the political, cultural and spiritual legacy of Saxon monarchy.' Therefore, it is not surprising that the thirteenth century Queen Margaret, whose father was eager to encourage the cult of Edward the Confessor and whose brother was named after the saint, was devoted to Dunfermline Abbey which was founded by her own 'Saxon' ancestor, and at which the saint was laid.<sup>233</sup>

St Margaret's genealogical link with the Saxon dynasty may have led Alexander to easily associate with other Saxon/English cults such as St Edmund of Abingdon whose feast day was the same as the date of St Margaret's death on 16 November, St Cuthbert at Durham and St Edward the Confessor rather than the symbol of anti-English royal, St Thomas Becket/Arbroath Abbey.<sup>234</sup> Moreover, Queen Joan (1210-38), who was a wife of Alexander II and a daughter of King John and died in 1238 leaving no offspring,<sup>235</sup> might have influenced Queen Margaret's dedication to St Margaret. Not to follow Queen Joan's infertility, Queen Margaret might have relied on St Margaret's night-sark because the saint would have been believed to aid women in pregnancy and delivery. Following Queen Margaret, her two sons, David (1272-1281) and Alexander (1264-1284), who had been

---

<sup>231</sup> *Chron. Bower*, v, 407-9, 500; *ESSH*, ii, 675-6; *RRS*, iv, nos. 106, 107, 109, 110.

<sup>232</sup> *Chron. Fordun*, i, 305.

<sup>233</sup> Boardman, 'Dunfermline as a Royal Mausoleum', 143-4.

<sup>234</sup> Penman, 'Royal piety in thirteenth-century Scotland', 24-5.

<sup>235</sup> *ESSH*, ii, 510.

perhaps born at Dunfermline, were buried there in 1281 and 1284 respectively.<sup>236</sup> In 1286 Alexander III himself was buried beside his wife Queen Margaret (d.1275) and his sons.<sup>237</sup> In addition, Alexander III named his daughter Margaret, who was born on 28 February 1261 and was married to the king of Norway, Eric in 1281.<sup>238</sup> It is also possible that the burials of his wife Queen Margaret and his two sons at Dunfermline probably led him to launch the erection of a Lady Chapel at Dunfermline Abbey at the end of the thirteenth century in order to accommodate the need for more space, although the evidence suggests that Alexander III and his family were buried in the south aisle,<sup>239</sup> as discussed in Chapter Three.

As Michael Penman has pointed out, Alexander III had also to be aware of a ‘collective spiritual identity’ of Scots, which would have been produced by Margaret’s canonisation and the relics’ translation, both of which would have been overseen by nobles and prelates when the king was a child. Alexander and his court may also have observed ‘the feast of Scottish Saints Columba, Kentigern, Andrew, Ninian and Giles.’<sup>240</sup> The feast of commemorating the translation of St Margaret and her death were also observed on 19 June and 16 November respectively by the crown.<sup>241</sup> In fact, although a saint represents holiness and spirituality, in reality, a saint is brought down to the secular and political level. Saints as political symbols and propaganda apparatus could provide those who exploited them with political legitimacy, and strengthen the political authority of those using saints. Baronial saints in later medieval England were good examples, showing how saints could be used for political and propaganda

---

<sup>236</sup> *Chron. Fordun*, i, 307.

<sup>237</sup> *Ibid.*, 307, 309; *Chron. Bower*, v, 409-11.

<sup>238</sup> *Ibid.*, 335, 459, 411.

<sup>239</sup> *ESSH* ii, 692.

<sup>240</sup> *Chron. Bower*, v, 22-3. For the cults of these Scottish saints see A. Boyle, ‘Notes on Scottish Saints’, *Innes Review*, xxxii (1981), 59-82; Macquarrie, ‘St Margaret of Scotland’, 211-23.

<sup>241</sup> The dates of St Margaret’s cults almost overlapped with the cults of St Edmund of Abingdon, because Alexander probably observed the translation and feast day of Edmund on 9 June and 16 November (Penman, ‘Royal piety in thirteenth-century Scotland’, 28). Alexander III was probably present at Dunfermline for the feast of St Margaret (16 November) in 1279 (*RRS*, iv, no. 128).

purposes by being employed as a symbol to warn the English king.<sup>242</sup> As English baronial saints did, St Margaret as a royal saint could be exploited for secular and political aims, in particular, so as to enhance the moral and symbolic power of Scottish monarchs. As already noted, Alexander II would have recognized it, and that was why he launched the process of canonisation. However, unfortunately he died before he heard the pope's permission to canonize Margaret. Additionally, it is unlikely that the king had occasion to be aided by the royal saint with the exception of probably the birth of his son, the future Alexander III in 1241. During his early reign, Alexander III was more interested in saints of the English, although Alexander III had a royal saint canonised officially by the pope. However, circumstances changed over time and he may have recognized the significance of Dunfermline. Along with his recognition of the moral and spiritual support from the royal saint and his predecessors to settle political tension, his wife Queen Margaret's death in 1275 was likely to influence the shift of his interest to Dunfermline.

As we have seen, the projects of Dunfermline Abbey - St Margaret's canonisation and translation - are relevant to that of Westminster Abbey launched in the second half of the thirteenth century by English king Henry III. The king's affection for the cult of Edward was probably formed in the period between 1233 and 1238,<sup>243</sup> and launched the reconstruction project of Westminster Abbey in 1245. The scheme provided the king with an opportunity to present his piety in public and his association with St Edward, which would have increased

---

<sup>242</sup>Theilmann, 'Political Canonization and Political Symbolism in Medieval England', 241-66; Walker, 'Political Saints in Later Medieval England', 77-106.

<sup>243</sup>Carpenter, 'King Henry III and Saint Edward the Confessor: The Origins of the Cult', 868-873. Henry III's favour to Westminster reflected his more frequent residence at Westminster than other places. During the period, Westminster was the place the king visited the most frequently. In addition to his personal favour, the loss of Normandy in 1204 could have led Henry to stay more frequently at Westminster than his Norman and Angevin predecessors. The king's frequent residence at Westminster Palace provided the monks of Westminster Abbey with opportunities for receiving generous patronage from the king, and for promoting the cult of St Edward (T. Craib, 'The Itinerary of King Henry III', edited and annotated (and analysed) by Steven Brindley and Stephen Priestley (English Heritage, c.1999), 13-5). Henry III's new role as a patron of Westminster Abbey coincided with political crisis, which was the fall of his Justiciar, Hubert de Burgh caused by Peter des Roches in 1232 (F. M. Powicke, *The Thirteenth Century: 1216-1307*, 2<sup>nd</sup> ed. (Oxford, 1962), 43-8; D. A. Carpenter 'The Fall of Hubert de Burgh', *Journal of British Studies* 19 (1980), 1-17). Under these difficult circumstances, Henry III probably realized that he needed the aid of the royal saint to overcome difficulties.

his authority into jurisdiction over the affairs of the church.<sup>244</sup> However, it was not until 1269 that the body of St Edward the Confessor was translated into its new shrine in the new abbey church of Westminster. As David Carpenter has pointed out, the translation took place on 13 October, because it was the saint's greatest feast day, the date of the first translation of the saint in 1163: moreover, the calendar of 1269 was exactly the same as that of 1163,<sup>245</sup> which is likely to be the same situation as the thirteenth-century translation of St Margaret - the same calendar of 1150, the year of the consecration of 'David's church', as that of 1251. Before the translation of 1269, the reign of Henry III had been in trouble because of two civil wars, between 1260 and 1261, and 1263 and 1267.<sup>246</sup> In spite of Henry III's incapacity in exercising actual power during such political turmoil, the king's ambitious building project could make further progress, because the barons had also benefited from promoting the cult of Edward. In fact, St Edward the Confessor, as Paul Binski has suggested, had had two different images: as a saint of 'mighty power, his saintliness exalted the kingship'; on the other hand, his 'apocryphal law shielded the community from tyrannical rule.'<sup>247</sup>

Henry III may have intended to make his own mausoleum or, at most, that of his immediate family at Westminster, because the architectural structure was not supposed to be the official royal mausoleum, and the space was also too confined to be that.<sup>248</sup> It was in 1290

---

<sup>244</sup> Lewis, 'Henry III and the Gothic Rebuilding of Westminster Abbey: The Problematic of Context', 162-3. As Lewis suggests, since the reconstruction was 'too sumptuous' a project, fundraising was demanded. For example, the indulgences, which on 26 July 1245 Pope Innocent IV granted, were probably one of means to raise funds for reconstruction.

<sup>245</sup> D. A. Carpenter, 'Westminster Abbey and the Cosmati pavement in politics, 1258-1269' in Lindy Grant and Richard Mortimer eds., *Westminster Abbey: The Cosmati pavements* (Aldershot, 2002), 42; Carpenter, 'Westminster Abbey in Politics, 1258-1269', 54-5; Cheney, *Handbook of Dates*, 88-9; Binski, *Westminster Abbey and the Plantagenets*, 93-100. For Henry's involvement in the design of the building of the abbey Church at Westminster see Wilson, 'Calling the Tune? The Involvement of King Henry III in the Design of the abbey Church at Westminster', 59-93.

<sup>246</sup> J.R. Maddicott, 'Edward I and the Lessons of Baronial Reform: Local Government, 1258-80' in P.R. Coss, S.D. Lloyd eds., *Thirteenth Century England* (Woodbridge, 1986), 1-9; M. Howell, *Eleanor of Provence* (Cambridge, 1998), ch. 10, 'A Troubled Peace'.

<sup>247</sup> Carpenter, 'Westminster Abbey and the Cosmati pavement in politics, 1258-1269', 39-42; Carpenter, 'Westminster Abbey in Politics, 1258-1269', 51-54; Binski, 'Reflection on La estoire de Seint Aedward le rei: hagiography and kingship in thirteenth-century England', *Journal of Medieval History* 16 (1990), 333-50.

<sup>248</sup> H. M. Colvin, *Architecture and the After-Life* (London, 1991), 139; Binski, *Westminster Abbey and the Plantagenets*, 91-2; D. M. Palliser, 'Royal Mausolea in the Long Fourteenth Century (1272-1422)', 4-5.

that the royal mausoleum was established at Westminster, by the burials of the relatives of King Edward (1272-1307) including his brother Edmund and his father's half-brother William de Valence, both of whom died in 1296. Apart from Edward I's genuine reverence to Edward the Confessor, Edward I's establishment of the royal mausoleum at Westminster, as D. M. Palliser has insisted, related to his initiative to develop 'London-Westminster as the normal centre of government,' in a modern sense, 'as a capital city'. Moreover, Edward would have transformed Westminster into a major royal monastery or mausoleum to compete with French monarchs' architectural propaganda at St Denis, Sainte-Chapelle and Rheims,<sup>249</sup> and integrated political and spiritual power.

Turning to Scotland, the projects at Dunfermline Abbey in the second half of the thirteenth century may have been similarly influenced by that of Henry III's action at Westminster in terms of the royal saint's or royal mausoleum's function in strengthening royal authority. However, in a different way, as Michael Penman has suggested, Alexander III was probably more influenced by Louis IX's (1214-70) scheme to alter his dynastic shrine at St Denis than by the establishment of Westminster as the Plantagenet mausoleum by Henry III and Edward I by the later thirteenth century. That is, the French monarch separated the royal burial place from the site for the ceremony of inauguration, while English royals focused on one place at Westminster. Alexander, whose inclination toward the Capetian dynasty was presumably strengthened by his second marriage to Yolande of Dreux in 1285, may have intended to keep Scottish royal devotions at their inauguration place at Scone and burial site at Dunfermline like the French traditions of Rheims and St Denis, even though the

---

<sup>249</sup> *Ibid.*, 7-9; Derek Keene, 'London from the Post-Roman Period to 1300' in D. M. Palliser ed., *The Cambridge Urban History of Britain I: 600-1540* (Cambridge, 2000), 215. Edward rebuilt St Stephen's Chapel at Westminster to probably compete with Sainte-Chapelle (Brown, Colvin and Taylor, *The History of the King's Works*, I, 510).

monks of Dunfermline Abbey, which was a royal mausoleum, as discussed in Chapter One, probably wanted to celebrate the rites of coronation and unction at their own abbey.<sup>250</sup>

In sum, Alexander III did not recognize the significance of Dunfermline in his earlier reign, in spite of two historical events in 1249 and 1250/1. However, his attitude toward Dunfermline Abbey changed in the 1270s. Along with his wife Queen Margaret's affection for the abbey, his recognition of the moral and spiritual support from the royal saint and Henry's attempt to strengthen his kingship by carrying on St Edward's translation in 1269 and the influence of the French monarch presumably led him to be aware of the significance of St Margaret as a royal saint and Dunfermline Abbey as a royal mausoleum. Additionally, Alexander III's second marriage with Yolande of Dreux in 1285 needed the intercession of St Margaret for the fertility of the marriage. Alexander III's death at Inverkeithing in 1286 en route to Kinghorn indicates that Queen Yolande had been at or near Dunfermline.<sup>251</sup> Moreover, Bower's statement indicating that the envoys returning from Saintes came to Clackmannan on St Catherine's day (25 November 1286) to meet guardians gathered there to wait for the queen's delivery of Alexander III's posthumous child<sup>252</sup> suggests that the queen was presumably at Dunfermline to give birth to a baby with the wish of St Margaret's aid.

Overall, from the point of view of monarchs' personal favour, the reigns of Alexander II and III were not the peak moments in the history of Dunfermline. However, given various aspects, in particular, the canonisation and the translation, the mid-thirteenth century was the most prosperous moment in the history of cult of St Margaret and Dunfermline Abbey. With

---

<sup>250</sup> Penman, 'Royal piety in thirteenth-century Scotland', 24-5. For the rivalry between Westminster Abbey and St-Denis Abbey see Jordan, *A Tale of Two Monasteries: Westminster and Saint-Denis in the Thirteenth Century*, ch. v. 100-29; For Sainte-Chapelle see Beat Brenk, 'The Sainte-Chapelle as a Capetian Political Program' in Virginia C. Raguin, Kathryn Brush, Peter Draper eds., *Artistic Integration in Gothic Buildings* (Toronto, 1995), 195-213. For French monarchs' burials see Elizabeth A. R. Brown, 'Burying and Unburying the Kings of France', 241-66; Georgia Summers Wright, 'A Royal Tomb Program in the Reign of St Louis', 224-43.

<sup>251</sup> *Chron. Bower*, v, 419-21.

<sup>252</sup> *Ibid*, vi, 10-11; Duncan, *The Kingship of the Scots 842-1292*, 178.

the two events, Dunfermline Abbey and St Margaret officially secured a status as a royal mausoleum and a royal saint, which would benefit the crown and kingdom in religious and political terms.

## **(7) The Guardians, King John and pre-Robert I (1286-1306)**

Alexander III's death in 1286<sup>253</sup> and the death of his heir, Margaret Maid of Norway at Orkney in 1290 on her way to Scotland caused a succession crisis, which was resolved in the Great Cause presided over by English King Edward I in 1291-2. At the court of the Great Cause, 104 auditors were assembled under Edward I: 'the court of 105 used under the Roman republic to settle questions of succession to property.' Twenty-four auditors were appointed as Edward I's council by the king, another forty each belonged to John Balliol of Galloway and Robert Bruce of Annandale.<sup>254</sup> Dunfermline abbot Radulf de Greenlaw (1275-96) was on John Balliol's side, along with other prelates such as William Fraser bishop of St Andrews, Henry Cheyne bishop of Aberdeen, William bishop of Dunblane, Mark bishop of the Isles, Henry bishop of Galloway and abbot of Scone.<sup>255</sup> The lesser nobles in Fife were also anointed as auditors of John Balliol: Patrick Graham of Kincardine, who died at the battle of Dunbar in 1297; Michael Wemyss, lord of Wemyss; Michael Scott of Balwearie; and Ralph Lascelles, who became sheriff of Fife after 1263x1272.<sup>256</sup> However, Duncan IV earl of Fife (1288-1353) was too young to be anointed as an auditor, and even his right to attend the inauguration of John Balliol at Scone in 1292 was delegated to Sir John de St John.<sup>257</sup>

From 1292 to 1294 King John Balliol may have intended to resolve land disputes between his subjects. His resolution of the cases indicated that he planned to reinforce royal authority by rewarding his loyal supporters. In the same vein, at his first two parliaments

---

<sup>253</sup> The monks of Dunfermline Abbey were presumably in charge of the funeral of Alexander III in 1286, just as they might have overseen the translation of St Margaret in 1250/1 when it was carried out in the absence of an adult monarch, although there is no extant document concerning the responsibility of the monks of Dunfermline for the funeral.

<sup>254</sup> G.W.S. Barrow, *Robert Bruce and the Community of the Realm of Scotland* (4<sup>th</sup> edition, Edinburgh, 2005), 52. For Margaret, Maid of Norway see *ESSH*, ii, 695.

<sup>255</sup> E.L.G. Stones and Grant G. Simpson, *Edward I and the Throne of Scotland 1290-1296: An Edition of the Record Sources for the Great Cause* (Glasgow, 1978), vol. ii, 84-5.

<sup>256</sup> *Ibid.*, 85; C.A. McGladdery, 'Graham family', *ODNB*, xxiii, 169 (<http://www.oxforddnb.com/view/article/54211>); PoMS, <http://db.poms.ac.uk/record/person/17143;4575;5808> accessed on 23 December 2013.

<sup>257</sup> John Bannerman, 'MacDuff of Fife' in Alexander Grant & Keith J. Stringer eds., *Medieval Scotland: Crown, Lordship and Community* (Edinburgh, 1998), 33; Barrow, *Robert Bruce*, 66.



John tried to clear up the local and regional disputes which had emerged since 1286.<sup>258</sup> During his short reign, 1292-96, he may have been interested in royal religious foundations, although he issued fewer acts to them in comparison with that of previous kings.<sup>259</sup> In his actions to venerate the church, the most impressive thing was his grants to Anthony Bek bishop of Durham. For example, John gave £50 of land in his liberty of Wark in Tynedale with the exception of the town of Wark to Anthony bishop of Durham and his successors,<sup>260</sup> and the king granted his English manors of Penrith, Scotby, Karlaton, Languathby, Salkilde, and Sowerby to the bishop.<sup>261</sup> These acts were issued in London on 20 June 1294 - the date of the second translation of St Edward the Confessor, whose name was the same as that of John's son - when John stayed there to attend Edward I's parliament in order to answer to the appeals of Restalrig, Reading Abbey and Macduff, Thane of Fife.<sup>262</sup> That John issued acts on the date of the second translation of St Edward gives us an insight into his attitude toward the English. Whatever his genuine approach on the saint was, he probably sought to obtain Edward I's favour. On 3 July 1295, the date of the translation of SS. Swithun (c.800-862) and Thomas the Apostle, John granted Anthony Bek bishop of Durham and his successors the manor of Wark in Tynedale in free alms.<sup>263</sup> Since the property of Durham was one of the crucial estates Balliol possessed in England, and John himself had attended the schools of Durham for a long time,<sup>264</sup> Durham may have drawn his attention. John's dedication to the church was not limited to Durham. He also expressed his generosity to Scottish religious

---

<sup>258</sup> Beam, *The Balliol Dynasty 1210-1364*, 132-42.

<sup>259</sup> Fifteen acts were issued during the time (*Handlist*, ii, nos. 367, 368, 369, 370, 373, 374, 379, 380, 381, 384, 391, 411, 412, 417, 421). Between 1286 and 1292 just three acts issued to religious communities: 'Letters patent ordering chamberlian to pay expense of royal chapel' in 1288; 'Letters patent granting to Friars Preachers of Edinburgh 3 chalders of corn' in 1286 x 1288; 'Percept to burgesses of Perth to pay to Friars Preachers of Perth 5 chalders of corn' (*Handlist*, ii, nos. 298, 350, 357).

<sup>260</sup> *Ibid*, no. 374; *CDS*, ii, no. 691.

<sup>261</sup> *Handlist*, ii, no. 373; *CDS*, ii, no. 692.

<sup>262</sup> Beam, *The Balliol Dynasty 1210-1364*, 139.

<sup>263</sup> *Handlist*, ii, no. 381; *CDS*, ii, no. 872.

<sup>264</sup> Beam, *The Balliol Dynasty 1210-1364*, 10, 84-5. In addition, John (I) (d.1268) had conflicted with the bishops of Durham over rights and prosperity, and at last John (I) had owed penitential homage to Durham by foundation of college, Oxford (Amanda Beam, 'John Balliol, the Bishops of Durham, and Balliol college, 1255-1260', *Northern History*, XLII: 2 (September, 2005), 239-56).

houses and churchmen such as the church of Glasgow; Robert Wishart bishop of Glasgow; monks of Melrose Abbey; the monastery of St Mary's at Lindores in Fife; the Friars Minors of Dundee; and the Friars Preachers of Linlithgow.<sup>265</sup>

With regard to Dunfermline Abbey, on 12 August 1293 John confirmed a grant, which had been given by King William, to Dunfermline of 100s. annually from the fermes of Edinburgh. This confirmation might have been associated with the 200<sup>th</sup> anniversary of Margaret's death, although no extant place-dates of Balliol royal acts identify its issue location.<sup>266</sup> Although the abbot of Dunfermline supported John Balliol at the court of the Great Cause, John did not use the abbey effectively on behalf of himself. Considering that the abbey was a royal mausoleum and his legitimacy as a king was weak, John could have used the abbey and the royal cult as propaganda to strengthen his authority by providing his gifts or requesting prayers for predecessors. However, whatever his intentions were, he hardly had time to do so. In addition, the early death of Margaret the Maid of Norway, who died in Orkney in 1290, may have denied John an opportunity to employ Dunfermline as propaganda. Under these circumstances, it is doubtful that Dunfermline Abbey as a royal mausoleum would have helped John raise his legitimacy by employing the abbey and the royal saint. Furthermore, as mentioned above, the possible hope and effort of Alexander II and Alexander III and the monks of Dunfermline to make Dunfermline Abbey a coronation church might have caused John to be reluctant to have a close association with the abbey. However, in spite of these circumstances, the treaty between Philip IV (1268-1314) and Balliol ratified at Dunfermline on 23 February 1296 was to be ratified not only by Balliol but also by 'the Scottish prelates, barons, knights and communities of the towns' at Philip's request,<sup>267</sup>

---

<sup>265</sup> *Handlist*, ii, nos. 367, 380; Beam, *The Balliol Dynasty 1210-1364*, 92; *Handlist*, ii, nos. 370, 404, 369, 379. According to place-dates of Balliol royal acts, Balliol was present at Stirling on 10 August 1293; at Edinburgh 12 August; at Buittle on 13 January (*Ibid.*, nos. 367, 368; Beam, *The Balliol Dynasty 1210-1364*, 301).

<sup>266</sup> *Handlist*, ii, no. 403; *Registrum de Dunfermelyn*, nos. 50, 52.

<sup>267</sup> *Handlist*, ii, no. 386; *Records of the Parliaments of Scotland to 1707* [hereafter, *RPS*] accessed on <http://www.rps.ac.uk/>; Nicholson, *Scotland*, 47. Seals attached as follows: the six burghs of Aberdeen, Perth,

indicating that Dunfermline was still considered a significant place in respect of political strategy. Furthermore, that the seal of the abbot of Dunfermline was also attached lets us speculate about the abbot's status in the Scottish political world. In 1300 William de Lamberton bishop of St Andrews extolled the sanctity of the abbey, mentioning the high state of discipline, the praiseworthy lives, and the charity of the monks, and then the bishop granted the monks of Dunfermline 'the vicarage of Dunfermline to render the monks still more fervent.'<sup>268</sup> From this fact, it is possible to draw deduction that in 1300 the 50<sup>th</sup> anniversary of St Margaret's translation and the 150<sup>th</sup> of the abbey's consecration were probably celebrated, even if it was not splendidly during occupation and crisis.

Edward I, who took Scotland under his control after John was deported to London in July 1296, knew that his dedication to the saints as political propaganda would give him benefit. Therefore, he showed his invocation of the saints even while he was on campaign. For example, he visited and offered alms to St Kentigern's tomb at Glasgow in 1301. Around 7-10 July 1296 when John Balliol swore his fealty to Edward at a parish church in Forfarshire nearby Arbroath Abbey, the English king perhaps celebrated the translation feast of Becket at Arbroath Abbey about 7 July 1296. Edward also observed the feast of St Thomas during his campaign against the Scots in 1300 and 1304-5.<sup>269</sup> However, among Scottish saints or Scottish religious houses, St Margaret at Dunfermline seems to be the most attractive to Edward I. Since St Margaret was a Saxon princess, the English king seems to have also considered St Margaret from a genealogical point of view. In this context, it can be understood that while English army were stationed at Dunfermline over a winter from 5 November 1303 to at least February 1304 before leaving for St Andrews and arriving there

---

Stirling, Edinburgh, Roxburgh and Berwick; the bishops of St Andrews, Glasgow, Dunkeld and Aberdeen; the abbots of Arbroath, Dunfermline, HolyRood and St Andrews; the earls of Buchan, Mar, Strathearn and Atholl; eleven barons.

<sup>268</sup> *Registrum de Dunfermelyn*, no. 122.

<sup>269</sup> Yeoman, *Pilgrimage in Medieval Scotland*, 21; Penman, 'The Bruce dynasty, Becket and Scottish pilgrimage to Canterbury, c.1178-c.1404', 353.

by 14 or 15 March 1304,<sup>270</sup> Prince Edward and King Edward I granted jewels - a gold ornament at the cost of 6½ marks and a golden clasp at the cost of 100s. - to the abbey,<sup>271</sup> and it is likely that Edward and his troops would have taken part in the feast of St Margaret on 16 November.

As D.E.R. Watt et al suggested, the monks of Dunfermline perhaps were aware that Edward considered Scotland as a 'land' but not as a kingdom any more, and they might have come to conclusion about the end of the kingdom of Scotland, 'especially after Comyn's submission to Edward I in February 1304, leaving only Fraser, Soulis and Wallace to lead the resistance.'<sup>272</sup> Under these circumstances, the monks of Dunfermline probably tried not to demonstrate their strong association with the late king Alexander III, therefore they might not have celebrated the anniversary of Alexander III's death on 19 March of that year. That is, the monks of Dunfermline presumably thought the war was lost and they accepted Edward's overlordship. In this context, Dunfermline Abbey probably sought Edward's generosity. In return, Edward gave Dunfermline Abbey grants. For example, responding to the appeal of the abbot and convent of Dunfermline to have a market in a nearby burgh called Kirkcaldy, in 1304 Edward granted them a weekly market there on Thursday, and a yearly fair in the octave of Easter for three days and also he permitted them to have free warren in the lands of Muskilburghe [Musselburgh], Kyngorn [Kinghorn], Kyrcaledyn [Kirkcaldy], Nithbren [Newburn] and Focherofe.<sup>273</sup>

---

<sup>270</sup> *Documents illustrative of the History of Scotland*, ed. J. Stevenson (Edinburgh, 1870), ii, 30; *Chron. Bower*, vi, 296-7, 421; *Ibid*, ix, 114.

<sup>271</sup> BL, Add. MS 8835, fols 121r, 122v; *CDS*, iv, 486-7.

<sup>272</sup> *Chron. Bower*, ix, 114.

<sup>273</sup> *CDS*, ii, no. 1624. In addition, in March 1305 Edward confirmed Dunfermline a similar privilege as in 1304, that is, a weekly market on Thursday at his manor of Kirkcaldy, a yearly fair for three days from Saturday in Easter week, and free warren in his demesne lands of Kyngorn, Kircaldyn, Nithbren and Fotheroffe (*Ibid*, no. 1653).

However, an English chronicle records that most of Dunfermline Abbey save the church was destroyed by Edward's soldiers in 1303.<sup>274</sup> If this statement is true, it can be suggested that although Edward recognized St. Margaret's association with the Anglo-Saxon dynasty and he showed his veneration of the saint, at the same time he treated the abbey with an act of war because Dunfermline Abbey was also considered as a significant place to the Scottish king for military and strategic purposes. However, there is some evidence demonstrating the falsity of the statement. Firstly, Edward's plan for the architectural operation at the abbey in 1303, even if the business did not begin because requested workers refused to come there.<sup>275</sup> Secondly, given that Dunfermline Abbey was the burial place of Queen Margaret (d.1275) who was a sister of Edward, it would not have been possible for Edward to command or allow the abbey to be destroyed. Thirdly, it would be strange for both Edward I and his son to offer jewels to Dunfermline in the winter of 1303-4 if the English king ordered or allowed his soldiers to destroy the abbey. Lastly, in 1335 the attendance of Sir John de Strivelyn, a knight of the English king, and his men, who were besieging the castle of Loch Leven, at the annual celebration of St Margaret,<sup>276</sup> suggests that St Margaret would have been venerated by the English during the period of war. Therefore, it is not accepted that save the church the most part of Dunfermline Abbey was destroyed by English troops in 1303. Instead, it can be said that some part of the abbey was damaged by taking the roof lead for English soldiers' war machines, which led to Edward's compensation for the roof lead of the abbey stripped by his soldiers,<sup>277</sup> and also the reconstruction of the refectory and Robert I's grant for the building operation.<sup>278</sup>

---

<sup>274</sup> *Flores Historiarum*, ed. H. R. Luard, Rolls Series 95 (London, 1890), iii, 311-3; Cowan and Easson, *Medieval Religious Houses: Scotland*, 58.

<sup>275</sup> F. Watson, *Under the hammer: Edward I and Scotland* (East Linton, 1998), 149.

<sup>276</sup> *Chron. Bower*, vii, 97-9. Edward Balliol's march to Dunfermline directly via Kinghorn in 1333 would have derived from strategic consideration rather than his plan for worshipping the royal saint and the royal mausoleum (*Ibid*, 73-5; *Chron. Fordun*, ii, 346).

<sup>277</sup> *CDS*, ii, nos. 1646, 1687. Edward also compensated Brechin Cathedral church, St Andrew Cathedral priory and Jedburgh Abbey for their roof lead stripped by Edwards's troop in 1305 (*Ibid*, nos. 1687, 1727)) and

## **(8) Robert I (1306-1329)**

Robert I's reign saw a number of devotional acts to the Church driven by personal and political motives.<sup>279</sup> His piety seems to have been affected by Edward I (1272-1307). Robert was probably a bachelor of Edward's chamber before 1296, often in touch with Edward I in England and Scotland until 1305 and also attended English parliaments of c.1302-6.<sup>280</sup> Edward I's religious acts may have been enough to affect Robert I. Edward's religious performances should be considered in their political context, which related to his political purpose.<sup>281</sup> Before the advance of his troops toward Scotland, he prayed to English saints such as the Confessor, St Thomas, and St John of Beverley in Yorkshire or St Cuthbert of Durham.<sup>282</sup> He also certainly knew the significance of royal piety as propaganda. One of the things he did in order to crackdown on Scotland was to take away Scottish royal religious icons from Scotland. In 1296 he took not only the 'Black Rude' or piece of the Holy Cross ('as well as bones, additional crosses and personal items'), which St Margaret had possessed and were kept in Edinburgh castle, but also the Stone of Destiny from Scone, and moved them to Westminster. Additionally, he took some other coffers and decorated reliquaries from Edinburgh castle.<sup>283</sup> He would have thought that by translating Scottish royal religious icons

---

Edward's grant of timber in Selkirk to the monks of Melrose in around 1307 so as to restore their dwelling destroyed by English soldiers (*Ibid*, no. 1982) can lead us to speculate that since Dunfermline was not given timber, the damage of the abbey might not have been serious. However, given that the timber roof stripped lead is apt to decay, stripping lead from the roof means that timber was required to restore the roof, and that Dunfermline Abbey also needed timber to restore the building, even though it was not granted by Edward unlike Melrose Abbey. If Dunfermline Abbey needed timber to repair the building, the forest of Dollar could provide the abbey with timber (*Registrum de Dunfermelyn*, no. 76).

<sup>278</sup> Nick Bridgland, 'Dunfermline Abbey: Cloister and Precinct' in Fawcett ed., *Royal Dunfermline*, 89-100. For Robert's grant for the reconstruction of the refectory see *ER*, i, 215.

<sup>279</sup> Penman, "Sacred food for the soul'?", 1035-1062; Penman, 'Robert I (1306-1329)' in Michael Brown and Roland Tanner eds., *Scottish Kingship 1306-1542* (Edinburgh, 2008), 20-48.

<sup>280</sup> *Sir Thomas Gray, Scalacronica 1272-1363*, ed. A. King (Woodbridge, 2005), 35; M. Prestwich, *Edward I* (London, 1988), 436-68, 523-35; Penman, "Sacred food for the soul'?".

<sup>281</sup> For Edward I's religious performances see Prestwich, 'The Piety of Edward I', 120-8; Penman, "Sacred food for the soul'?"; J. Alexander and P. Binski eds., *The Age of Chivalry: Art in Plantagenet England, 1200-1400* (London, 1987), ch. X; Penman, "Sacred food for the soul'?".

<sup>282</sup> *CDS*, ii, no. 1177, 1441; Prestwich, 'The Piety of Edward I', 120-8; *Itinerary of Edward I, List and Index Society* no. 135 (London, 1977).

<sup>283</sup> *CDS*, ii, no. 840 and nos. 432, 494, 525, 706, 799; Penman, "Sacred food for the soul'?"

from Scotland to England, the holy power, which God gave to the Scottish monarch, could not work anymore for Scotland.<sup>284</sup>

For Robert I, one of the best places to demonstrate his legitimacy was Dunfermline Abbey,<sup>285</sup> which had been revived as a royal mausoleum after 1249 through the efforts of Alexander II and III to establish the cult of St Margaret, just as English kings had done for St Edward the Confessor at Westminster.<sup>286</sup> Issuing acts to Dunfermline on and around the dates of Alexander II's and III's deaths and Robert I's own birthday, Robert intended to keep his duty as a pious king,<sup>287</sup> by which he could have been expected to have an image of being associated with the Canmore kings. Just as John Balliol tried to settle the land conflicts at the beginning of his reign, so Robert I faced conflicts over land ownership. The parliament held at Cambuskenneth on 6 November 1314 issued the Statute of Disinheritance on those who had died without giving their allegiance to Robert, or who had not yet done so. By the Statute, lands frequently were 'resigned, or forfeited, or simply held by another.'<sup>288</sup> Robert I rewarded his supporters by giving land, as John did. Dunfermline Abbey received forfeited estates on 8 July 1321 (the death date of Alexander II); on 25 July (or subsequent days) 1323 and on an unknown date.<sup>289</sup> Moreover, Dunfermline Abbey was given privileges concerning a cocket

---

<sup>284</sup> If so, why did Edward not take the relics from Dunfermline Abbey, which was a Scottish royal mausoleum? An answer could be found in Edward's generosity to Dunfermline Abbey, in which the Anglo-Saxon princess and his own sister were interred. It is also possible that even though St Margaret's shirt would have been kept at Dunfermline, there might be no Scottish royal religious icon at Dunfermline as valuable as the Stone of Destiny and the 'Black Rude'.

<sup>285</sup> During the reign of Robert I, abbot of Dunfermline was Hugh (1304-1306-1313) appeared in acts as a witness on 1 March 1313 (*RRS*, v, nos. 30-34) and on c. 26 February - 1 March 1313 (*Ibid*, no. 390). After him, Robert de Crail (1314-1328) became abbot. As a witness in acts, he appeared on 16 February 1314 and on 5 March 1326 (*Ibid*, nos. 39, 293).

<sup>286</sup> M. Ash, 'The Church in the reign of Alexander III', in N.H. Reid ed., *Scotland in Reign of Alexander III, 1249-86* (Edinburgh, 1988), 31-53; Binski, *Westminster Abbey and the Plantagenets*, ch. 2.

<sup>287</sup> Penman, 'Robert I (1306-1329)', 36-7; *RRS*, v, nos. 6 (it was issued 20 March 1309), 8 (8 July 1321) and 190 (10 July 1321). For possibly dates of liturgy during Robert I's reign see 'Appendix' in Penman, 'Sacred food for the soul?'

<sup>288</sup> *RPS* accessed on <http://www.rps.ac.uk/>; *RRS*, v, 19-20; Roland J. Tanner, 'Cowing the Community? Coercion and Falsification in Robert Bruce's Parliaments, 1309-1318' in Keith M. Brown and Roland J. Tanner eds., *Parliament and Politics in Scotland, 1235-1560* (Edinburgh, 2004), 61.

<sup>289</sup> Dunfermline was granted 'Inverkeithing Kirk dedicated to St Peter, forfeited by Roger de Moubray (*Registrum de Dunfermelyn*, no. 346).' For Roger de Moubray see Barrow, *Robert Bruce*, 145, 401-403; Penman, 'A fell coniuracioun agany Robert the douchty king: the Soules conspiracy of 1318-1320', *Innes Review*, vol. 50, no. 1 (Spring 1999), 45. On 25 July (or subsequent days) 1323 Dunfermline took 'entry to the

seal and customs. In fact, goods could not be exported ‘without a cocket, that is, a certificate under the seal of a proper officer that the great custom had been paid on it; and every burgh of export had its cocket seal and cocket clerk.’<sup>290</sup> The *Exchequer Rolls* demonstrate the existence of cockets of the royal burghs of Linlithgow, Inverkeithing, Stirling, Cupar and Tarbert, and the earl of Moray’s burgh of Lochmaben, and the church burgh of Dunfermline between 1327 and 1330.<sup>291</sup> Concerning the cocket of Dunfermline, on 22 July 1326 Robert I issued ‘letters patent to the chamberlain to secure recognition of the cocket of Dunfermline Abbey.’<sup>292</sup> On 10 July 1321 the king sent the letter to the town of Bruges, requesting that ‘the cocket seal of Dunfermline Abbey be accepted as a royal one.’<sup>293</sup> Robert I also sent the letter to ‘the collectors of customs at Perth to allow the sums paid to Dunfermline Abbey as new great custom.’<sup>294</sup> These facts indicate that the abbey contributed to the economic development of Dunfermline burgh. In return, the burgh would have supported the abbey in financial terms.

Nobles also granted their patronage. In 1316 Duncan earl of Fife at the request of Abbot Ralph did homage to the abbot for the lands of Cluny, which his ancestor, Malcolm, had given to the abbey. In 1317 John de Graham gave the church of Newlands in Tweeddale to the abbey. In 1321 Thomas Randolph earl of Moray granted the land of Cullelouch [Cullaloe] in Fife and forty shillings.<sup>295</sup> Apart from this gift to Dunfermline, Robert’s acts for

---

lands at Moulin (Perthshire) which had been granted at feuferum to David de Hastings and David [de Strathbogie] is now forfeited (*Registrum de Dunfermelyn*, no. 365).’ For David de Strathbogie see Barrow, *Robert Bruce*, 355-8; The cases of William de Orford and of Geoffrey son of Gilbert were also probably similar to the above-mentioned cases. The abbey obtained ‘the forfeited holdings of late William de Orford burgess of Berwick (*Registrum de Dunfermelyn*, no. 356); ‘act to Dunfermline Abbey of the Ferryfield beside Inverkeithing, resigned by Geoffrey son of Gilbert (*Ibid*, no. 368).’

<sup>290</sup> *ER*, i, c.

<sup>291</sup> *Ibid*, ci, 79, 99, 101, 175, 177, 275, 328.

<sup>292</sup> *Registrum de Dunfermelyn*, no. 369.

<sup>293</sup> *Ibid*, no. 361.

<sup>294</sup> *Registrum de Dunfermelyn*, no. 362. There is no evidence to let us know how much customs was paid to Dunfermline. We can know just, according to *ER*, the extent to how much customs was collected in some burghs. In 1327 the customs of Berwick amounted to £673 2½ d., those of Edinburgh to £439 3s. 9d., Aberdeen £349 10s. 4d., Dundee £240 4s. 8½ d., Perth £108 1s. 9d., Linlithgow £14 9s. 1d., Cupar-Fife £13 6s. 0.75d., Inverkeithing £8 2s. 10d., Ayr £3 4s., Stirling £2 11s. 8d. (*ER*, i, 75-83).

<sup>295</sup> *Registrum de Dunfermelyn*, nos. 348, 350, 357.



Dunfermline - only two acts for Dunfermline recorded lay witnesses - suggests the possibility that Edward Bruce earl of Carrick (and lord of Galloway), Thomas Randolph earl of Moray and James Douglas, Lord of Douglas would have had a relationship with Dunfermline.<sup>296</sup> With the exception of two acts issued in 1314 to grant the kirk of Kinross (dedicated to St Serf) and chapel of Orwell (between modern Milnathort and Lochleven, dedication: St Serf) to the abbey, Dunfermline Abbey was not given any patronage by the crown until 8 July 1321 when Robert I gave a grant for perpetually lighted wax-candle in front of St Margaret's shrine,<sup>297</sup> although Robert I was probably present at Dunfermline on 16 November (St Margaret's feast day) 1314 to give thanks to the aid of St Margaret at the battle of Bannockburn in 1314.<sup>298</sup> In this context, the moment when nobles gave grants to Dunfermline Abbey overlapped with the period when the monks of the abbey would have sought patronage.

Robert I's patronage to Dunfermline served more than his political purpose. Out of his personal piety, he gave patronage to Dunfermline for the salvation of his predecessors, successors and himself.<sup>299</sup> Unfortunately it is unknown how often Robert I visited Dunfermline. However, it is possible to speculate from the extant record of the king's itinerary. Robert was perhaps present at Dunfermline about 20 March 1309 (19 March, the date of Alexander III's death);<sup>300</sup> about 16 November 1314 (St Margaret's feast day);<sup>301</sup> from around 16 to 20 January 1324;<sup>302</sup> and around 22 July 1326.<sup>303</sup> The king may have been

---

<sup>296</sup> *RRS*, v, nos. 43, 413.

<sup>297</sup> *Registrum de Dunfermelyn*, nos. 341-2; *RRS*, v, nos. 43-4. For the grant of wax-candles see *Registrum de Dunfermelyn*, no. 346; *RRS*, v, no. 188. For the dedications of religious houses, M. Ash, 'The Administration of the Diocese of St. Andrews 1202-1328', Appendix Five: Parish Churches and Parish Chapels in the Diocese of St. Andrews, 381-91.

<sup>298</sup> *RRS*, v, no. 44. Around from 6 to 14 November 1314, he was perhaps at Cambuskenneth (*Ibid*, nos. 41-3).

<sup>299</sup> *Registrum de Dunfermelyn*, no 341, 345, 346, 356, 360, 369. Naming one of his daughters Margaret may have mirrored his genuine belief in St Margaret (*Chron. Bower*, vi, 377).

<sup>300</sup> *RRS*, v, nos. 5-6.

<sup>301</sup> *Ibid*, no. 44. Around from 6 to 14 November 1314, he was perhaps at Cambuskenneth (*Ibid*, nos. 41-3).

<sup>302</sup> *Ibid*, nos. 249, 250, 247, 248.

<sup>303</sup> *Ibid*, no. 303.

at Dunfermline around 5 March 1324 when his sons, David and John, were born there,<sup>304</sup> before he probably went to Aberdeen to stay from 12 March to 8 April 1324, as the place-dates of Robert's acts demonstrate.<sup>305</sup> In addition to these dates, as Michael Penman has suggested, Robert I was perhaps at Dunfermline 29 June 1318, the feast day of St Paul and Peter, via Stirling about 24 June 1318, the anniversary of Bannockburn and the day of St John Baptist. But on 5 July 1318 Robert took part in the consecration of the completed St Andrews Cathedral church.<sup>306</sup>

At Robert's request, his heart was buried at Melrose and his body was interred at Dunfermline. Just as his corpse was separated, so Queen Elizabeth de Burgh's (d.1327) organs were buried in the church of the Virgin at Cullen and her body was presumably laid in the north of the choir at Dunfermline, as discussed in Chapter Three. Division of the royal corpse encouraged the proliferation of royal relics and pilgrimage stations, and the expansion of Masses for the crown throughout the realm.<sup>307</sup> It could also be said that Robert intended to further develop Dunfermline as a mausoleum for the extended royal family and their spouses with the extension of the church, that is, the erection of 'the Lady Chapel' at the north of the choir, which was probably begun in the later thirteenth century and completed perhaps in the late fourteenth century, as discussed in Chapter Three. Robert's support for Dunfermline Abbey was similar to Edward I's scheme to support Westminster for the tombs of his family, relatives and his key military and political followers. As a result of Robert's plan, by the 1350s Queen Elizabeth (d.1327), Thomas Randolph earl of Moray (d.1332); Sir Andrew Moray of Bothwell (d.1338) who was the third husband of Robert's sister Christina Bruce,

---

<sup>304</sup> *Chron. Fordun*, i, 350-1.

<sup>305</sup> *RRS*, v, nos. 25-3.

<sup>306</sup> Penman, 'Robert I (1306-1329)', 22; *Chron. Bower*, vii, 413.

<sup>307</sup> Penman, "'Sacred food for the soul?"; Boardman, 'Dunfermline as a royal mausoleum', 150.

and Christina Bruce herself (d.1356/1357); and Robert's daughter, Matilda Bruce (d.1353), were all buried at Dunfermline.<sup>308</sup>

Robert would have wanted to reinforce his association with the Canmore dynasty by his burial at Dunfermline in 1329. The funeral of Robert I was presumably overseen by Thomas Randolph, who became Regent after the death of the king. However, Robert himself was presumably involved in the preparation of his funeral in his life time. For example, the statement in the *Exchequer Rolls* indicating that Robert Barber was paid £13 6s. 8d. in August 1329 for unknown work relating to Robert's tomb carried out in the previous year<sup>309</sup> suggests that Robert's long illness could let him make arrangements for his own tomb in his life time. Actually, prior to his preparation of the tomb, an act issued at Dunfermline on 16 November 1314 (the feast day of St Margaret) indicates that Robert considered his burial at Dunfermline.<sup>310</sup> Considering Robert's achievements, his funeral would be carried out splendidly, even if from the remaining fragmentary evidence it is only possible to speculate about how magnificent the funeral was. In 1329 Thomas of Charteris, who was in charge of production of Robert's French marble tomb, was paid £66 13s. 4d..<sup>311</sup> The mason was paid £38 2s. and there is a payment of £12 10s. to bring the tomb to Dunfermline from Paris via Bruges.<sup>312</sup> The commission of the tomb in France means that it may have followed those of French monarchs in the late thirteenth and fourteenth centuries: 'a white marble-clad tomb-

---

<sup>308</sup> *Ibid*, 150. For Thomas Randolph, Matilda and Christina see *Chron. Bower*, vii, 65, 275, 305. For Sir Andrew Moray see *Chron. Fordun*, i, 363; Penman, 'Robert I (1306-1329)', 37; Penman, *David II*, 'Genealogical Table', xiv. Robert's daughter, Margaret, who married William de Moravia earl of Sutherland in 1345, also died in the 1340s, in 1346 (*Chron. Bower*, vi, 37, 377, 461).

<sup>309</sup> *ER*, i, 214.

<sup>310</sup> *RRS*, v, no. 44.

<sup>311</sup> *ER*, i, 213.

<sup>312</sup> *Ibid*, 214. Besides these expenses, there are other payments including these: a splendid hearse, *capella*, of Baltic timber, which was built to stand over the King's body at the funeral day, cost £5 5s 10d. (*Ibid*, 150, 215); in 1330 a payment of £22 8s. 2d. to John of Lesydwyn for ironwork on the king's tomb and a gown (*Ibid*, 288); 1,500 sheets of gold-leaf for decorating the tomb (*Ibid*, 150, 221); 562 stones 5lbs. of wax requested for candles and torches during the funeral procession (*Ibid*, 151, 232).

chest, surmounted by effigy and canopy' with black marble plinth.<sup>313</sup> Since no record survives to identify the full cost of the funeral, it is not possible to know its exact cost. However, that £1,000 was allocated for Andrew Murray's ransom 1334-5, which was originally intended to pay for Masses for Robert I, and £682 was paid for Robert II's tomb at Scone Abbey in 1390<sup>314</sup>- although there was fiscal depreciation after 1350 - makes it possible to speculate about the cost of Robert I's funeral. While Robert I's funeral was held at Dunfermline, the impressive scene may have been engraved on the mind of the minority king at the age of five, which would partly affect his later attitude toward the abbey.

As mentioned above, Dunfermline may have been attractive to Robert's rival, Edward I. Since St Margaret was a Saxon princess, he may have invoked the saint's mercy. Robert may have realized St Margaret's ambiguous position: Scottish royal saint as well as Saxon princess.<sup>315</sup> That is perhaps why it was emphasised to invoke St Andrews, St John the Baptist and St Thomas rather than St Margaret before a battle such as Bannockburn in 1314.<sup>316</sup> However, as mentioned in Chapter One, Scottish soldiers invoked St Margaret at the battle of Bannockburn. Although Robert I certainly had personal piety, his concern about religion was based on his political purpose. To encourage national identity and pride, he used Scottish and local saints such as St Ninian, St Columba, St Andrew, St Malachy, St Kentigern and St Fillan as well as St Thomas, a potentially anti-Plantagenet saint.<sup>317</sup> In the same vein, he gave patronage to crucial abbeys such as at Melrose where Robert's heart was buried after it had

---

<sup>313</sup> Iain Fraser, 'The Tomb of the Hero King: The Death and Burial of Robert I, and the Discoveries of 1818-19' in Fawcet ed., *Royal Dunfermline*, 169-74. Unlike the tombs of French Monarchs in the late thirteenth century and probably Robert's tomb, the tomb of Edward I consists of 'a free-standing tomb-chest, situated between the arcade piers of St Edward's Chapel' but 'the tomb-chest of Edward II does not contain the king's coffin, which lies in a vault underneath (*Ibid*, 173).' With regard to the tomb of Robert I, it was believed that the remains discovered upon a vault, near the east end, where high altar stood, in 1818 were those of Robert I. However, Iain Fraser has cautiously insisted that there is no definitive evidence to identify that the bones found were Robert's (*Ibid*, 155-76).

<sup>314</sup> *ER*, i, 450-1; Penman, *David II, 1329-71* (Edinburgh, 2004), 60, 412.

<sup>315</sup> In the 'Liber Extravagans', Bower described St Margaret's genealogy tracking back to Anglo-Saxon dynasty (*Chron. Bower*, xi, 99-103).

<sup>316</sup> 'John the Baptist...and St Andrew and St Thomas who shed his blood along with the saints of the Scottish Fatherland [and] will fight today for the honour of the people, with Christ the Lord in the van (*Ibid*, vi, 363-6).'

<sup>317</sup> Penman, "Sacred food for the soul??"

been carried to the Holy Land, and Arbroath dedicated to St Thomas, the saint to whom Robert's regime was strongly devoted.<sup>318</sup>

In spite of St Margaret's ambiguous position, Robert seems to have exploited the royal cult and the royal mausoleum at Dunfermline as propaganda in order to strengthen his legitimacy by showing his association with the Canmore kings. In this context, Robert tried to keep or reinforce the status of Dunfermline Abbey as a royal mausoleum, just as Edward I did at Westminster. Robert's attempt perhaps corresponded to the aim of the monks of Dunfermline to repair the abbey's reputation and damage during the war.<sup>319</sup> Robert I died on 7 June 1329 eleven days after Trinity Sunday of the year on 18 June,<sup>320</sup> and his funeral was carried out in the absence of an adult king. The monks of Dunfermline Abbey might also have been in charge of the funeral, just as they may have been for the 1250/1 translation and Alexander III's funeral in 1286 as discussed above. Robert's funeral completed his achievements as it coincided with the Papal bull lifting the excommunication of the king and permitting the anointment of Scottish kings, as discussed below.<sup>321</sup>

---

<sup>318</sup> For Robert's heart burial at Melrose and Crusade see *RRS*, v, no. 380; *CDS*, iii, nos. 990-1; G.G. Simpson, 'The Heart of King Robert I: Pious Crusade or Marketing Gambit?' in Crawford ed., *Church, Chronicle and Learning in Medieval and Early Renaissance Scotland*, 173-86; S. Cameron, 'Sir James Douglas, Spain and the Holy Land' in Terry Brotherstone and David Ditchburn eds., *Freedom and authority: Scotland c.1050-c.1650. historical and historiographical essays presented to Grant G. Simpson* (East Linton, 2000), 108-17; Penman, 'The Bruce dynasty, Becket and Scottish pilgrimage to Canterbury, c.1178- c.1404', 356; Michael Prestwich, *The Three Edwards: Wars and State in England, 1272-1377* (London, 1980), 35. For Arbroath Abbey see Robert issued 30 acts for Arbroath, 20 to Melrose and 18 to Dunfermline see *RRS*, v. The favour of Robert's regime to Arbroath is likely to relate to abbot Bernard of Arbroath (d. c.1331) who was also chancellor of Scotland during the greater part of Robert's reign (*RRS*, v, 138-58 ['Itinerary']).

<sup>319</sup> However, as far as the establishment of the royal cult or tradition is concerned, he lost good opportunities. For example, as Michael Penman has insisted, he accepted too easily Westminster's refusal to send the Stone of Scone back in 1328. In addition, returning Edward II's seal and shield to England after Bannockburn, Robert missed a chance to give them to a royal abbey or employ them in a future Scottish royal coronation (Penman, 'Robert I (1306-1329)', 38-9).

<sup>320</sup> *Chron. Bower*, vii, 45; Cheney, *Handbook of Dates*, 148-9.

<sup>321</sup> *ER*, i, cii, cxii, cxiii, n. 1.

## **(9) David II (1329 - 71)**

On 24 November 1331 David II's coronation was held and he was anointed at Scone by James Ben bishop of St Andrews. David was the first Scottish king to be anointed.<sup>322</sup> In fact, this rite was Robert I's greatest religious achievement. Shortly after he died, on 13 July 1329 the pope allowed the Scottish kings to have the rite of full coronation and anointment, for which David II was to pay 12,000 florins of gold (£2,000) to the pope.<sup>323</sup> It must have been an honour for the minority king at the age of seven to start his career with the holy ceremony, regardless of his understanding of it. In spite of the honourable beginning of his career, the real world did not allow the young king to sit on his throne comfortably. The king went into exile into Normandy in 1334 and stayed there until 1341. Meanwhile, Dunfermline Abbey relied on the patronage of the nobles such as William earl of Ross, who was a Justiciar and commanded to the sheriff of Fife to pay the eighth of the fines of his last itinerary to the abbey in 1339.<sup>324</sup> While the king was in exile, he might have been influenced by religious activities he encountered in the diocese of Rouen, where he stayed at Château-Gaillard in Normandy, a region in which there were almost 60 Becket dedications, including Henry II's Priory itself.<sup>325</sup> These circumstances made him increase his awareness of St. Thomas, an anti-Plantagenet symbol, which had been promoted by his father, Robert, to compete with the English. His attitude toward St Thomas at that time was mirrored by his first stop and offering gifts to Arbroath Abbey after returning to Scotland in 1341.<sup>326</sup>

---

<sup>322</sup> *Chron. Bower*, vii, 71; *ER*, i, 403. David II's coronation was long delayed until, as Michael Penman suggests, he was seven years old and healthy so that he repeated the oaths in person during the ceremony (Penman, *David II*, 44-5).

<sup>323</sup> *ER*, i, cxiii, n. 1; *Calendar of Entries in the Papal Registers relating to Great Britain and Ireland: Petition to the Pope*, ed. W.H. Bliss (16 vols., London, 1896), ii, 493; *Vetera Monumenta Hibernorum et Scotorum Historiam Illustrantia*, ed. A. Theiner (Rome, 1864), 244-5.

<sup>324</sup> *Registrum de Dunfermelyn*, no. 376.

<sup>325</sup> Penman, 'The Bruce dynasty, Becket and Scottish pilgrimage to Canterbury, c.1178-c.1404', 361.

<sup>326</sup> Michael Penman, 'Christian days and knights: the religious devotions and court of David II of Scotland, 1329-71', *Historical Research*, vol. 75, no. 189 (August, 2002) 253; J. Gillingham, *Richard I* (Norfolk, 1999), 301-6; W. Moir-Bryce, 'The Black Friars of Edinburgh', *Book of the Old Edinburgh Club*, iii (1910), 40. David arrived at Inverbervie on about 2 June 1341 (Penman, *David II*, 77-8). He issued acts for protecting property of Arbroath Abbey at Arbroath and Dundee on 17-18 June 1341 (*RRS*, vi, nos. 25-9).

From his return to Scotland in June 1341 until his capture at Neville's Cross in October 1346, David gave patronage to religious communities and churchmen such as Arbroath Abbey, Scone Abbey, the bishop of Aberdeen, Holyrood Abbey, the friars Preacher of Ayr, the priory of Coldingham, the church of Glasgow, the friars Preacher of Perth, Dunfermline Abbey and Newbattle Abbey.<sup>327</sup> In particular, during this period of time, David was present at Dunfermline on 30, 31 December 1342; 17 September 1343; and on his birthday on 9 March 1345.<sup>328</sup> He might have visited Dunfermline with the hope of St Margaret's aid for a pregnancy for Queen Joan.

However, David seems to have been more interested in making his image as a leader in war against England and in encouraging men of chivalry, knights and esquires, until he was captured in 1346. In 1346 political motivation may have prompted David's piety. When he crossed the border to attack England, he carried a relic once possessed by St Margaret, a piece of Christ's Holy Cross. This was not the original 'Black Rood' which was taken by Edward I in 1296 and was still kept in the English treasury in 1346, but a cross which may have been taken from Edinburgh castle or David's favoured abbey of Holyrood.<sup>329</sup> The Holy Cross, which would have been believed to protect the Scots from their enemy at the battle, did not affect fully the Scottish force in spiritual and military terms. The Scots were defeated at the battle of Neville's Cross. Bower later criticized David's wrong decision of waging the battle against the English, mentioning that St Cuthbert appeared in David's dreams and warned him not to attack the church land of Durham.<sup>330</sup>

While David II was detained in England from 1346 to 1357,<sup>331</sup> he would have observed Edward III's personal piety and his knowledge of how to employ his religiosity as

---

<sup>327</sup> *Ibid.*, nos. 25-9, 33-4, 48-50, 55, 59-60, 65-7, 70-1, 74, 76, 82-4, 86-8, 90, 91, 98, 101, 109.

<sup>328</sup> *Ibid.*, nos. 60-62, 75, 86.

<sup>329</sup> Watson, 'The Black Rood of Scotland', 28-47; Rollason, 'Spoils of War? Durham Cathedral and the Black Rood of Scotland', 57-65; Penman, 'The Scots at the Battle of Neville's Cross, 17 October 1346', 176, n. 57.

<sup>330</sup> *Chron. Bower*, vii, 257-9.

<sup>331</sup> Penman, 'The Scots at the Battle of Neville's Cross, 17 October 1346', 157-80; Penman, *David II*, 136-93.

propaganda,<sup>332</sup> and exploit English saints to raise national pride and boost soldiers' morale before battles.<sup>333</sup> As Michael Penman has suggested, witnessing Edward III's patronage to the saints, after he returned to Scotland in 1357 David displayed his devotion to a number of Scottish national saints and celebrated regional cults, including St Monan/St David (1 March) and St. Ninian (26 August). Just as Edward III invoked English saints to raise national pride and to build up his authority, so David would have intended to use the Scottish saints and their cults. Although the date of feast and translation of St Margaret (16 November, 19 June) and the feast of St Andrew (30 November), another national saint, are not left blank by the royal charters as public celebration days, Bower claimed that the feast day of St Margaret was celebrated annually during David's reign.<sup>334</sup>

---

<sup>332</sup> Edward III owned one of the largest relic collections including, as mentioned above, not only the 'Black Rude' and some of St Margaret's bones, but also additional crosses and personal items St Margaret had possessed. In addition, the relics includes 'a thorn from the Crown of Thorns and a fragment of the True Cross known as the Neith Cross' and 'relics of Sts. Leonard, John the Baptist, James the Less, Agnes, St Margaret of Scotland, Mary Magdalen, Agatha, Jerome, Adrian, Sylvester, and the eleven thousand virgins as well as the alb and chasuble of Edward the Confessor, a bone from the arm of St. Amphibalus, the blood of St. George, and the blood and hair of St. Stephen (Arnold Taylor, 'Royal Alms and Oblations in the Later 13<sup>th</sup> Century' in Frederick Emmison and Roy Stephens, eds., *Tribute to an Antiquary: Essays Presented to Marc Fitch* (London, 1976), 119, n. 49; Prestwich, 'The Piety of Edward I', 126-7; Ormrod, 'The Personal Religion of Edward III', 856-7).'

<sup>333</sup> Edward III visited shrines to invoke the saints. With the exception of St Mary who ranked high in Edward's venerations, most of the saints and shrines Edward venerated were exclusively English. He visited Canterbury annually carrying the relic of a sword, by which the saint had been killed, to the tomb of Becket. He also visited the Lady Chapel at Christ Church before going to St Augustine's Abbey. In 1353 he granted Canterbury Cathedral a gold statue of St Thomas (at a cost of £40). He also showed his veneration to Anglo-Saxon royal saints, St. Edmund of Bury and St. Edward the Confessor. Being baptized on the same day as the feast day of the Confessor, Edward III normally gave alms to Westminster Abbey to celebrate the feast. The king took part in the translation of St Thomas Cantilupe in 1349 and stopped by there again in 1353 (*Ibid*, 858-9). Moreover, Edward III prayed to the northern English saints such as 'Cuthbert of Durham, William of York, John of Beverley, Oswin of Tynemouth and Wilfrid of Ripon' at the campaign against Scotland. Along with these, major shrines in the southeast were visited by the king when he went to crucial wars at the Continent and came back from there. Edward III seems to make a decision early to use Westminster Abbey as a royal burial place, as did Edward I. On 24 August 1339 Edward III asked monks of Westminster Abbey to translate the body of his brother, John, who had died at Perth in 1336 and was buried at Westminster, into another place, in order to reserve 'the most honourable positions for the repose and burial of us and of our heirs.' (WAM the Westminster Abbey Muniments 6300\* in W. M. Ormrod, 'The Personal Religion of Edward III', 868 n. 109; Binski, *Westminster Abbey and the Plantagenets*, 177; Palliser, 'Royal Mausoleum in the Long Fourteenth Century (1272-1422)', 9).

<sup>334</sup> Penman, 'Christian days and knights', 257-8; *RRS*, vi. David's dedication to St Ninian may have been influenced by his father, Robert, who had a genuine personal interest in the cult of St Ninian (D. Brooke, *Wild Men and Holy Places: St Ninian, Whithorn and the Medieval Realm of Galloway* (Edinburgh, 1994), chs. 7-8; J.E. Fraser, 'Northumbrian Whithorn and the Making of St Ninian', *Innes Review*, 53 (2002), 40-59). *Chron. Bower*, vii, 99. For royal acts issued on the date of 16 November see *RRS*, vi, 229 (The witnesses are Patrick [*de Leuchars*], bishop of Brechin and chancellor; Robert, steward of Scotland and earl of Strathearn; Thomas, earl



Above all, the dedication to St Thomas was the most impressive. David's captivity in England for 11 years from 1346 would have been the turning point in his attitude to the saint and his cult at Canterbury. The most influential motivation in the development of his own devotion to the saint would have been his observation of the faith in the saint of Edward III, his subjects and even other war prisoners during his captivity in England. His strategic consideration concerning his release from captivity was also a crucial motivation in the development of his association with the cult of the saint.<sup>335</sup> David, who was challenged by the Stewarts, his heirs presumptive, seemed to have employed St Thomas to advance on 'pro-English, anti-Stewart agenda', just as Robert could encourage his subjects to be against England with the devotion of the cult of St. Thomas.<sup>336</sup> David's attitude toward St. Thomas mirrored his affection for Arbroath Abbey, which had been dedicated to St. Thomas. From 1357 to 1371, he gave 15 grants to the abbey. It was the highest number of grants he gave to a religious house.<sup>337</sup> Another crucial saint during the reign of David was St Monan, who was a sixth century Irish missionary, and whose cult was based in the east of Fife between Earlsferry and Crail.<sup>338</sup> The presence of a royal religious centre in Fife would have enabled

---

of Mar; Robert de Erskine, knight; and John de Preston, knights), 418, 479; *RMS*, i, no. 279, App. 2. no. 1577; *Ibid*, no. 296, App. 2. no. 1617.

<sup>335</sup> Penman, 'The Bruce dynasty, Becket and Scottish pilgrimage to Canterbury, c.1178-c.1404', 361; Penman, 'Christian days and knights', 256. For David II's religious acts for St Thomas and Canterbury see M.A.E. Green, *Lives of the princesses of England*, 6 vols (London, 1849-55), vol. 3, 114-59; Ormrod, 'The Personal Religion of Edward III', 858; Webb, *Pilgrimage in Medieval England*, 130-3, 202-3; B. Dobson, 'The monks of Canterbury in the later Middle Ages', in P. Collinson, N. Ramsay and M. Sparks eds., *A History of Canterbury Cathedral* (Canterbury/Oxford, 2002), 145; Robertson ed., *Materials for the History of Thomas Becket, archbishop of Canterbury*, vol. 2, 270-9.

<sup>336</sup> Penman, 'The Bruce dynasty, Becket and Scottish pilgrimage to Canterbury, c.1178-c.1404', 362-5.

<sup>337</sup> *RRS*, vi, nos. 152, 172, 182, 223, 255, 256, 276, 314, 360, 384, 432, 433, 434, 440, 454; Melrose Abbey, where the heart of David's father was buried, was given the second largest number of grants by David. As a successor of his father, David may have considered himself as a patron of the abbey like his father (*Ibid*, nos. 151, 164, 168, 169, 194, 195, 219, 227, 237, 254, 442, 450). In addition, the king may have been involved in the Abbot of Arbroath's request for an additional relics from Canterbury in 1358 (*Litterae Cantuariensis*, ed. J.B. Sheppard, 3 vols. (Rolls Series, London, 1887-9), vol. 2, no. 851; Penman, 'The Bruce dynasty, Becket and Scottish pilgrimage to Canterbury, c.1178-c.1404', 362).

<sup>338</sup> *Chron. Bower*, vii, 261, 464n; Penman, 'Christian days and knights', 258; David paid over £613 between 1362 and 1371 to build the church of St. Monan (*ER*, ii, nos. 114, 137, 138, 169, 175, 178, 221, 259, 289, 307, 347, 357).

David to secure control over the earldom of Fife, for which he competed with Robert the Steward.

Concerning Dunfermline Abbey, given its geographical and traditional status, the abbey which was a royal mausoleum and his parents' burial place might also have strengthened David's power in Fife, although the king's relationship with the abbey was weaker than that with St Monan. From the second half of 1344 to autumn 1345 David provided patronage to crown-founded churches and towns, and gave almost two hundred grants to local men in order to enhance his regional power.<sup>339</sup> The grants to Dunfermline Abbey would have been given in the same context. In 1344-5 David granted Dunfermline Abbey the land of Pitreavie in Dunfermline. On 15 April 1345 the king issued a patent to the officers of Edinburgh, Haddington and Linlithgow not to interfere with Dunfermline Abbey's liberties.<sup>340</sup> It was in 1363 that Dunfermline Abbey received several grants from the king.<sup>341</sup> In the spring of 1363, David confronted a rebellion by the Stewarts, Douglas and March, which ended up with the Steward's submission oath of fealty to David on 14 May 1363. In addition, a charter was issued for the confirmation of a grant of Robert I to Robert Lauder at Dunfermline on 1 October 1363.<sup>342</sup> Thus, David could sort out dynastic and domestic problems. Between 9 March and 20 November 1363 - after which he travelled to London - David gave a number of grants to useful men and crucial churches to further strengthen his regional support.<sup>343</sup> In particular, John abbot of Dunfermline was one of those who witnessed

---

<sup>339</sup> *RMS*, i, App, ii, nos. 888-1010; Penman, *David II*, 110-12.

<sup>340</sup> *RMS*, i, App. ii, nos. 944, 948; *RRS*, vi, no. 90.

<sup>341</sup> On 4 August 1363 the King gave the abbey the land of Garnekere in the sheriffdom of Clackmannan and the land of Tillicoultry with a mill-house in the sheriffdom of Clackmannan (*RMS*, i, no. 144 and App. ii, no. 1444; *Ibid*, i, no. 145 and App. ii, no. 1446). On 24 October 1363 David confirmed that the burgesses and merchants of the abbey had 'the liberty of buying and selling within the bounds of the regality of the abbey' and of the burghs, Dunfermline, Kirlaldy, Musselburgh and Queensferry. On the same day, David confirmed also that the abbey had a 'port at the grange of Gellet or at West Rosyth' (*Registrum de Dunfermelyn*, nos. 390-1).

<sup>342</sup> *RMS*, i, no. 163 and App. 2, no. 1479; *RRS*, vi, 336. In addition, a charter to John Herries was issued at Dunfermline on 12 June 1368 (*RMS*, i, no. 282 and App. 2, no. 1574; *RRS*, vi, 425. Then David married Margaret of Logie at Inchmurdach in Fife as late as c. February 1364 (*Chron. Bower*, vii, 497).

<sup>343</sup> Penman, *David II*, 283-95. For David's grants see *RRS*, vi, nos. 289-311 and *RMS*, i, nos. 97-8, 100, 105, 129, 136-8, 140, 142-6, 148-53, 155-6, 158-61, 162-9, 170-1, 173-5, 186.

the king's wedding as well as the Steward's oath,<sup>344</sup> which leads us to think that the abbot was one of the significant figures in Scotland.

In addition, the names of the abbots of Dunfermline appeared as witnesses on royal acts. Alexander Ber abbot of Dunfermline, who had been appointed as abbot in 1328-9 and died in 1350 or early 1351 when he returned to Scotland from the Jubilee celebrations at Rome, was listed as a witness on an act issued on 17 June 1341, which was the first act after David's return to Scotland from France. John de Stramiglaw, who succeeded Alexander Ber, was also found as a witness on acts issued on 11 January 1360; 26 October 1360; 14 September 1362.<sup>345</sup> Abbot John was also named on the list of safe-conducts travelling to London in 1363, along with David's strong supporters.<sup>346</sup> Apart from abbots of Dunfermline named on David II's acts for Dunfermline as witnesses, the king's acts named Robert Steward, earl of Strathearn; William Douglas, earl of Douglas; Robert of Erskine, chamberlain of Scotland; Archibald Douglas, son of James Douglas; and John of Herries, knight as lay witnesses.<sup>347</sup>

<sup>344</sup> For David's marriage see *Chron. Fordun*, i, 382; *Chron. Bower*, vii, 323-9. For the Stewart's swear see *Ibid*, 331-3.

<sup>345</sup> *RRS*, vi, nos. 25, 229, 243, 278; After Alexander Ber died, the convent of Dunfermline Abbey elected John Black as abbot. However, John de Stramiglaw, whose origin is unknown but presumably connected with Strathmiglo in Fife, went to Avignon from Paris and obtained the pope's provision to appoint him as abbot of the abbey. It was possible because the pope had a right of reservation to all the dignities held by a dead man on a pilgrimage (*Ibid*, 277, 472; Watt, *A Biographical Dictionary of Scottish Graduates to A.D. 1410*, 519-20).

<sup>346</sup> Penman, *David II*, 304-5.

<sup>347</sup> *RRS*, vi, no. 257. Moreover, lay witnesses to acts issued at Dunfermline are as follows: Robert the Steward of Scotland; Duncan, earl of Fife; John Randolph, earl of Moray; Patrick de Dunbar, earl of March; Thomas Charteris, chancellor; Maurice de Murray, knight; and Malcolm Fleming, knight.

Lay witnesses to acts issued at Dunfermline during the reign of David II	
<i>RRS</i> , vi, no. 60 ([30] December 1342)	Robert the Steward of Scotland; Duncan, earl of Fife; John Randolph, earl of Moray; Patrick de Dunbar, earl of March; Thomas Charteris, chancellor; Maurice de Murray, knight; and Malcolm Fleming, knight
<i>Ibid</i> , no. 61 ([31] December 1342)	Robert the Steward of Scotland; Duncan, earl of Fife; John Randolph, earl of Moray; Patrick de Dunbar, earl of March; Thomas Charteris, chancellor; Maurice de Murray, knight; and Malcolm Fleming, knight
<i>Ibid</i> , no. 62 ([31] December 1342)	Robert the Steward of Scotland; John Randolph, earl of Moray; Patrick de Dunbar, earl of March; Thomas Charteris, chancellor; Maurice de Murray, knight; and Malcolm Fleming, knight
<i>Ibid</i> , no. 75 (17 September 1343)	None
<i>Ibid</i> , no. 86 (9 March 1345)	None

As far as extant acts are concerned, the king stayed at Dunfermline Abbey on special occasions. Three acts were issued at Dunfermline on 30 December 1342, and crucial men such as William bishop of St. Andrews, Robert Stewart, Duncan earl of Fife, John Randolph earl of Moray, Patrick de Dunbar earl of March, Maurice de Moravia earl of Strathearn and Malcolm Fleming earl of Wigtown were recorded as witnesses. Therefore, David stayed there with these crucial men at Christmas of 1342,<sup>348</sup> which also indicates that the royal court was presumably held in a guesthouse of the abbey. According to the *Exchequer Rolls*, Dunfermline Abbey was also provided spices and confections (at a cost of £6 2s. 10d.) for David's birthday (5 March) in 1342.<sup>349</sup> Since it was his first birthday after returning from exile, it is perhaps that he wanted his birthday to be celebrated by the monks of the royal monastery, at which he was born on 5 March 1324.<sup>350</sup> David also issued an act at Dunfermline on 9 March 1345,<sup>351</sup> which means that he stayed there again on his birthday (5 March). The place-date of another act indicates that David would have been at Dunfermline on 17 September 1343,<sup>352</sup> which possibly related to the 250<sup>th</sup> jubilee anniversary of St Margaret's death. In addition, in 1368 he was present at Dunfermline around the date of his father's, Robert I's death (7 June).<sup>353</sup> He visited Dunfermline Abbey on 1 October 1363<sup>354</sup> around the date of his mother's death (27 October). In particular, the purpose of his visit on 1 October 1363 would

<i>Ibid.</i> , 336 (1 October 1363); <i>RMS</i> , i, no. 163 and App. 2, no. 1479	None
<i>RRS</i> , vi, 425 (12 June 1368); <i>RMS</i> , i, no. 282 and App. 2, no. 1574	None

<sup>348</sup> *RRS*, vi, nos. 60-2. However, it is unlikely that David was at Dunfermline on the feast day of St Margaret (16 November), because according to his itinerary he was founded at Kildrummy, Aberdeemshire on 27 August (*Ibid.*, no. 57), 28 November again (*Ibid.*, no. 58) and at Dumbarton on 10 December (*Ibid.*, no. 59).

<sup>349</sup> *ER*, i, 483.

<sup>350</sup> *Chron. Bower*, vii, 13.

<sup>351</sup> *Ibid.*, no. 86.

<sup>352</sup> *RRS*, vi, no. 75.

<sup>353</sup> David issued a charter at Dunfermline on 12 June 1368 (*RMS*, i, no. 282 and App. ii, no. 1574).

<sup>354</sup> *Ibid.*, no. 163 and App. ii, no. 1479.

have included his intercessory prayer in the hope of pregnancy for his new wife, given his second marriage held in May 1363.

David's relatives and his major followers, as already noted, were also buried at Dunfermline during his reign. Additionally, David's Queen, Margaret Drummond purchased a marble tomb (at the cost of £10) to prepared for her tomb at Dunfermline alongside her royal ancestors in 1368,<sup>355</sup> which might have related to David's visit to Dunfermline on 12 June 1368, as place-dates of royal acts demonstrate.<sup>356</sup> The purchase of a stone implicates that as Richard Fawcett suggests, the eastern part of the church was perhaps reorganized in the second half of the fourteenth century,<sup>357</sup> including the completion of the Lady Chapel. This reorganization of the church building at Dunfermline might have been derived from the intention to restore or promote the reputation of Dunfermline Abbey as royal mausoleum, after it had been damaged during the war.

Although David's relatives and key supporters were buried at Dunfermline, he was buried at Holyrood Abbey in 1371, which was probably relevant to his spiritual association with the abbey because his household chaplains had come from the abbey since 1342. A more reasonable explanation, as Michael Penman suggests, is perhaps because Holyrood Abbey was so close to the king's death place, Edinburgh castle.<sup>358</sup> In addition, his affection for a piece of Christ's Holy Cross, which once had been possessed by St Margaret and probably kept at Holyrood Abbey, and carried into battle at Neville's Cross in 1346, presumably motivated his burial at the abbey. Moreover, since his Stewart successor, Robert II, who wanted to open a new era of the Stewart dynasty, would have been reluctant to expose the

---

<sup>355</sup> *ER*, ii, 300, 348; *Registrum Episcopatus Glasguensis* (Bannatyne Club, 2 vols, Edinburgh, 1843), ii, nos. 304-8.

<sup>356</sup> *RRS*, vi, 425; *RMS*, i, no. 282 and App. ii, no. 1574. However, since place-dates of royal acts indicate that David appeared at Scone from 14 June [1368] to at least 25 June (*RRS*, vi, nos. 397-401), the king was not to stay at Dunfermline on the feast of St Margaret, 19 June.

<sup>357</sup> Fawcett, 'Dunfermline Abbey Church', 51; *ER*, ii, 300.

<sup>358</sup> Penman, *David II*, 412. He died at Edinburgh castle on 22 February 1371 (*Chron. Fordun*, i, 382; *Chron. Bower*, vii, 361).

funeral procession in public, which would draw the subject's attention, Robert II probably preferred to complete the funeral rite as soon as possible. Under these circumstances, David's interment at Holyrood was likely to be determined by Robert II's intention rather than David's own initiative. Therefore, although David was not buried at Dunfermline Abbey, it is obvious that the abbey was a burial place for the members of the Scottish royal family and its supporters by the 1360s.

Concerning David's burial at Holyrood but not at Dunfermline, another possibility can be suggested. Apart from Queen Margaret Drummond's affection for Dunfermline Abbey until her death in Marseilles c.1373, David seems to have lost his interest in the abbey during the latter part of his life. Most of his grants to Dunfermline Abbey and his visits there occurred before 1346 with the exception of his presence at Dunfermline in 1363, which was a crisis year for him, and 1368. This trend may have related to his infertility. Dunfermline Abbey and St Margaret were associated with royal childbirth. Queen Annabella, wife of Robert III (1368–1401) chose Dunfermline as a location for her son James' birth in 1394. In 1450-1 Mary of Guelders (c.1434-63), James II's wife, possessed St. Margaret's 'sark' or shirt while she was delivered of a baby. In 1512 James IV's wife also used St. Margaret's sark during her delivery.<sup>359</sup> In particular, Elizabeth de Burgh (c.1289-1327), mother of David himself, chose Dunfermline to give birth to the future David and probably a twin, John in 1324.<sup>360</sup> Therefore, it is possible that since David was not successful in receiving St Margaret's aid for having an heir, he would have been disappointed with the saint. It may have made him lose his affection for St Margaret and Dunfermline Abbey during the latter part of his life. In addition, that his estranged first wife, Joan (1321-62), who was sister of

---

<sup>359</sup> For Annabella see E.W.M. Balfour-Melville, *James I, King of Scots 1406-1436* (London, 1936), 281-3. For Mary of Guelders see *Miracula*, xxxviii-xxxix and *ER*, v, 447, 512. For James IV's wife see *Accounts of the Lord High Treasurer of Scotland*, eds., T. Dickson and J. Balfour Paul, 4 vols. (Edinburgh, 1877-1902) [hereafter *TA*], iv, 334.

<sup>360</sup> *Chron. Fordun*, i, 350-1; Penman, *David II*, 19.

Edward III, was a pious English princess led him to turn his interest away from Dunfermline, because St Margaret was also an English princess.

## **(10) The Early Stewart Kings (1371-1406)**

The Stewarts had held the titles of Strathearn from 1358, Menteith from 1361 and Fife from 1371,<sup>361</sup> and Robert Stewart was crowned at Scone on 26 March 1371.<sup>362</sup> He was the second king crowned with the full coronation rite. Of 397 extant acts, Robert II issued 75 (18.9%) acts in Edinburgh.<sup>363</sup> Given that 302 (58.3%) of 518 extant acts were issued in Edinburgh during the reign of David II,<sup>364</sup> the status of Edinburgh in royal administration terms declined during the reign of Robert II. As king Robert II frequently visited the regions in and around Perthshire and the old 'Stewart' lands in Renfrew, Bute and Ayrshire. That is, Perth, Scone and Methven were crucial centres for the kingship. The king issued a number of acts in these regions. Of 397 acts 80 were issued at Perth, 22 at Scone, 26 at Methven. In comparison with them, 11 acts were issued at Dunfermline.<sup>365</sup>

Robert II's concentration on these three regions may have mirrored his affection for the Augustinian abbey at Scone dedicated to the Holy Trinity and St Michael the Archangel.<sup>366</sup> In his life time Robert had already decided to be buried at Scone Abbey, a few miles away from his own residence at Methven, in which he stayed often, so that he prepared for his tomb at Scone rather than a royal mausoleum at Dunfermline. He brought his tombstone from England by ship, carved by Nicholas Haen the king's mason and decorated by Andrew the painter, and then moved it from Holyrood to Leith, from there headed to Perth

---

<sup>361</sup> Stephen Boardman, *The Early Stewart Kings: Robert II and Robert III 1371-1406* (East Linton, 1996), 11, 51; Penman, *David II*, 260, 414.

<sup>362</sup> *Chron. Fordun*, ii, 382; *Chron. Bower*, vii, 367.

<sup>363</sup> Boardman, *The Early Stewart Kings*, 93.

<sup>364</sup> Extrapolated from *RRS*, vi.

<sup>365</sup> Boardman, *The Early Stewart Kings*, 91-5; Stephen Boardman, 'Robert II (1371-1390)' in Brown and Tanner eds., *Scottish Kingship*, 76-7. In spite of Robert II's frequent stay in and around Perthshire, Renfrew, Bute and Ayrshire, it was just one occasion that he gave the grant to the religious houses to venerate the cults of saints being popular in the regions. On 9 March 1389 Robert II granted the 'lands of the baronies of Kilwinning and Beith' to 'the Blessed Virgin Mary, St Winnin, and the abbot and convent of the monastery of Kilwinning' (Database of Dedications to Saints in Medieval Scotland accessed on <http://webdb.ucl.ac.uk/saints/>; M.A. Hall, 'Of holy men and heroes: the cult of saints in medieval Perthshire', *Innes Review*, vol. 56, no. 1 (Spring 2005), 61-88)). Therefore, it is hard to say that he was interested in cults of saints in the regions. For Robert's hunting see J. M. Gilbert, *Hunting and Hunting Reserves in Medieval Scotland* (Edinburgh, 1979), 36, 61, 66, 80, 95; *Liber Pluscardensis*, ed. F. J. H. Skene [hereafter *Chron. Pluscarden*], i, 311.

<sup>366</sup> Hammond, 'Royal and Aristocratic Attitudes to Saints and the Virgin Mary in Twelfth and Thirteenth century Scotland', 72.



by ship.<sup>367</sup> In the end, Robert died at Dundonald castle in Ayrshire on 19 April 1390 and his body was carried to Scone and buried there on 25 April 1390, which is the same date as the feast of St. Mark and the inauguration of Malcolm III.<sup>368</sup> Robert's interment at Scone, the inauguration/coronation site for the Scottish kings, could provide his successor with an opportunity to be crowned shortly after his funeral,<sup>369</sup> although it did not come true as discussed below. The expenditure for the burial totalled £682 15s. 1d., which was paid in three instalments, and one of the payments included part of the expenses of Robert III's coronation. Although Scone as a place for royal inauguration had a long relationship with the Scottish kings, since 1093 Scone Abbey had never been chosen as a burial place of the royal families with the exception of the interment of Queen Matilda, David I's wife in 1130-1.<sup>370</sup>

Alongside the preparation for his own tomb at Scone, Robert II also expressed his affection for the abbey in his life time. He gave the abbey the sum of 51s. 8d. in 1373 and £5 3s. 4d. in 1375, 1376, 1377, 1379.<sup>371</sup> Since the *Exchequer Rolls* reported only these payments, it is uncertain whether the grant continued to be paid or not. However, it was probably intended for Robert to give the grant to the abbey every year. The *Exchequer Rolls* demonstrates that from May 1387 to June 1388 the amount of £177 17s. 10d. was spent at Scone and Perth,<sup>372</sup> although no breakdown of the expenditure is extant. He visited Scone on special occasions. For example, in 1372 and 1390 he visited there around 26 March, the date of his own coronation (the Feast of the Annunciation of the Blessed Virgin Mary: 25 March,

---

<sup>367</sup> Cowan and Easson, *Medieval Religious Houses: Scotland*, 97; *ER*, ii, 585, 592, 608, 622, and iii, 348.

<sup>368</sup> *The Original Chronicle of Andrew Wyntoun*, ed. F.J. Amours, Scottish Text Society, 6 vols. (1903-14) [hereafter *Chron. Wyntoun* (Amours)], vi, 354-5; *Chron. Bower*, vii, 447; For the date of Robert's burial see Oxford, Bodleian Library, MS Fairfax 23, f. 116 (from Boardman, 'Coronations, Kings and Guardians: Politics, Parliaments and General Councils, 1371-1406' in Brown and Tanner eds., *Parliament and Politics in Scotland, 1235-1560*, 113).

<sup>369</sup> Boardman, 'Coronations, Kings and Guardians: Politics, Parliaments and General Councils, 1371-1406', 113-4.

<sup>370</sup> *ER*, iii, 242, 279, 280. For the burial of Queen Matilda see *Chron. Fordun*, i, 233; *The Charters of King David I*, nos. 46-7.

<sup>371</sup> *ER*, ii, 410, 486, 541, 572, 595.

<sup>372</sup> *Ibid*, iii, 174.

and Robert I's inauguration at Scone on 25-27 March 1306). Robert II also enjoyed Christmas at Scone in 1388.<sup>373</sup>

Regular convocation of Parliaments at Scone from the 1330s may also have affected Robert II's affection for Scone. In spite of David II's supervision of the parliaments, he faced powerful opposition at parliaments until the rebels were cracked down in 1363. At that time, Robert II was the most crucial figure of the opposition.<sup>374</sup> The parliaments were held at Scone on eleven occasions of sixteen during the reign of David II.<sup>375</sup> Therefore, his experience at the Parliament might have led him to have an emotional impression of Scone. Additionally, Robert II presumably planned to follow the English kings' policy, which supposed to make Westminster Abbey the site for royal rites as well as political assembly and royal funerals. That is, Robert II may have intended that Scone Abbey would be the place for the coronation ceremony as well as the royal burial rites, which would have been a reversal of the plan Dunfermline presumably made in the thirteenth century.

As for the king, Paisley Abbey founded by Walter Fitz Alan, the founder of 'the royal house of Stuart', in which his predecessors were buried, may have been more valuable than Dunfermline Abbey.<sup>376</sup> Although Robert II himself was not supposed to be interred at Cluniac Paisley Abbey, he tried to make the abbey a memorial monument. In 1375 Robert II paid £12 14s. 10d. for transporting alabaster for the tombs of his father (d.1326) and grandfather (d.1309) to Linlithgow from Leith. From there the alabaster was carried to

---

<sup>373</sup> *RMS*, i, nos. 405, 412, 525, 551, 817, 820, 831, 834, 873. For at Christmas at Scone see *ER*, iii, 210. For the Feast of the Annunciation of the Blessed Virgin Mary see A. J. M. and J. K. Mousolfé, *Saint Companions for Each Day* (new revised edition, Mumbai, 2005), 114. For Robert I's inauguration date see Penman, *David II*, 17.

<sup>374</sup> Penman, 'Parliament Lost - Parliament Regained? The Three Estates in the Reign of David II, 1329-1371' in Brown and Tanner eds., *Parliament and Politics in Scotland, 1235-1560*, 74-101. For Parliament at Scone see Oram, 'Community and Realm: The Middle Ages', 44-5.

<sup>375</sup> Five parliaments were held at Perth. With regard to Councils, Perth (9), Scone (1), Edinburgh (5), Aberdeen (2), Dundee (4) and Others (6) (Penman, 'Parliament Lost - Parliament Regained?', 101, n. 100).

<sup>376</sup> For Walter Fitz Alan see W.M. Metcalfe, *A History of Paisley 600-1908* (Paisley, 1909), 4-5. For the Stewarts' association with Paisley see Barrow, 'The earliest Stewarts and their lands' in Barrow, *The Kingdom of the Scots*, 314-6.

Paisley Abbey.<sup>377</sup> By 1380 the king had organized the construction and decoration of two more alabaster tombs for his mother Marjory Bruce (d. c.1317) and his first wife Elizabeth Mure.<sup>378</sup> In 1389 Robert II ordered stained glass windows at a cost of £30 for Paisley Abbey.<sup>379</sup> Through the enlargement and the decoration of his ancestors' burial site, Robert II raised his predecessors' status and consequently strengthened his kingship.

Robert I and Robert II both were not a son of the previous king. While Robert Bruce took the throne by murdering a rival, Robert II was recognised as a presumptive heir in a 'new parliament tailzie of 15 July 1326'.<sup>380</sup> Due to this difference, their attitudes toward their own ancestor's tombs and the established royal mausoleum were different. Robert I seems to have tried to show himself as a successor of the Canmore kings, because he took over the reins of the kingdom after killing his rival and thus the legitimacy of his kingship was shaky. Thus, he intended to emphasise his association with the Canmore kings through dedication to Dunfermline Abbey, the royal mausoleum. However, Robert II had been appointed as a presumptive heir and was crowned by law, although he faced some opposition to his succession. Therefore, he did not need to demonstrate himself as a successor of the Canmore kings. Indeed what was required in order to raise his status as a king was presumably to emphasise the virtues and accomplishments of his own family and ancestors. Additionally, Robert II did not need St Margaret's miraculous power for fertility from 1371, because he had already many sons and daughters. The project to augment Paisley Abbey may have been carried out in this context. In addition, Robert II seems to have attempted to reinforce the legitimacy of his kingship by constructing the history of his ancestors in genealogical terms. He sponsored John Barbour (c.1320-1395) archdeacon of Aberdeen, and author of *The Bruce* (c.1371x5), to write a history under the title *The Stewarts' Original*. Although it is not extant,

---

<sup>377</sup> *ER*, ii, 503.

<sup>378</sup> *Ibid*, ii, 622 and iii, 32.

<sup>379</sup> *Ibid*, iii, 222. For the building phrases of Paisley Abbey see Richard Fawcett, 'Paisley Abbey Church: The Medieval Architecture' in John Malden ed., *The Monastery & Abbey of Paisley* (Renfrewshire, 2000), 37-49.

<sup>380</sup> Nicholson, *Scotland*, 116.

the references to it from the chroniclers such as Andrew of Wyntoun and Walter Bower enable us to reconstruct some parts of it. According to Barbour, the Stewarts were descended from Dardanus, lord of Frigia, which gave the Stewarts a long history stretching back to Brutus, king of Britain.<sup>381</sup>

However, Robert II seems to have recognized that Dunfermline Abbey still deserved to be given his patronage. In 1388 Robert II granted an altar chapel of St Mary at Dunfermline 10s. annually from the rent of Pitreavie, Dunfermline.<sup>382</sup> Robert granted £5 every year to John de Stramiglot (1351-1383x1388) abbot of Dunfermline from fermes of Edinburgh from 1373, and £2 from fermes of Haddington from 1372.<sup>383</sup> To be precise, the grant to the abbot of Dunfermline was an annuity, a trend which began under Robert II's reign. Leading people in Scotland were given an annuity during his reign, in return they served the king as his retinue or supported the throne.<sup>384</sup> Therefore, that the abbot received an annuity means that he belonged to members of the leading men in Scotland. It also gives us an insight into the status of Dunfermline Abbey. Even if Robert II did not consider the abbey as his own burial site, he seems not to have ignored the significance of the abbey. Just as it was Dunfermline Abbey where the treaty meeting for the Franco-Scottish alliance took place on 23 February 1296,<sup>385</sup> so the envoys of France and England came to Dunfermline to have the treaty meeting for solving the military conflict between Scotland and England during the guardianship of Robert Stewart, Robert II's third son and earl of Fife - and being created as duke of Albany in 1398 -

---

<sup>381</sup>Boardman, 'Late Medieval Scotland and the Matters of Britain' in Edward J. Cowan and Richard J. Finlay eds., *Scottish History: The Power of The Past* (Edinburgh, 2002), 51-5; Boardman, *The Early Stewart Kings*, 59-60. For Dardanus see *Chron. Wyntoun* (Laing), ii, 152, 200, 314 and *Chron. Wyntoun* (Laing), v, 256.

<sup>382</sup>*ER*, iii, 166.

<sup>383</sup>For from fermes of Edinburgh see *Ibid*, ii, 411, 488, 536, 570, 592, iii, 15, 60, 75, 102, 129, 139, 160, 214, 232, 259, Exceptionally, in 1388 the abbot was paid two time, £7 10s. and £2 10s. respectively (181, 197). For from fermes of Haddington see *Ibid*, ii, 385, 411, 487, 535, 579, 589, iii, 16, 59, 73, 103, 129 (in 1384, 20s).

<sup>384</sup>*Ibid*, iii, lxxxii-lxxxiii. Significant figures given annuity include as follows: duke of Albany, sir John of Ramorgny, sir Murdach Stewart, earl of Crawford, sir William Lindsay of Byres, sir William Stewart of Jedworth, sir John Montgomery of Eglissham, sir William of Danyelstoun, earl of Moray, Alexander of Ogilvy, Walter Forrester and William Cockburn of Skirling and so on (*Ibid*, lxxxiii-lxxxiv).

<sup>385</sup>*RPS* accessed on <http://www.rps.ac.uk/>

on 6 July 1389. It may have represented the status of the abbey as well as geographical convenience.<sup>386</sup>

Apart from the grants Robert gave to Dunfermline, he also gave patronage to another church dedicated to St. Margaret. On 14 February 1390 shortly after his demise, he granted annually £8 from the customs of Edinburgh to the chapel of St Margaret in Edinburgh castle, and on 3 December 1390 the patronage was confirmed by Robert III.<sup>387</sup> It is possible to speculate from place-dates of acts Robert issued how often he visited Dunfermline Abbey. He stayed at Dunfermline around 20 October 1373; he may have been there until the feast of St. Margaret on 16 November. The king stayed at the abbey for another feast of St Margaret (19 June). He appeared at Dunfermline on 22 July 1374 via Inverkeithing (on 19 June 1374), a toft of which Walter fitz Alan, the first hereditary Steward of Scotland (c.1150-1177) - the later family surname, Steward, was derived from this office - gave to Dunfermline in perpetual alms for the souls of King Malcolm IV.<sup>388</sup> Robert II came to Dunfermline on 28 March 1390. He appeared at Inverkeithing on 26 June 1376 and 11 October 1376. He also stopped at Inverkeithing while he was coming and going to Dunfermline to attend the festivals on 16 November and 19 June.<sup>389</sup> In addition, that Queen Euphemia Ross, who had first married John earl of Moray, the second son of Thomas Randolph, and later Robert II in 1355, was interred at Dunfermline in 1387<sup>390</sup> suggests that the queen may have had a deep relationship with Dunfermline Abbey, which possibly related to her pregnancies/childbirths of David Stewart and Walter Stewart.

---

<sup>386</sup> Boardman, *The Early Stewart Kings*, 164-8; *Chron. Bower*, vii, 445. Preparing for the meeting, the abbey was given £19 11s. 10d to buy wine, spices and cloths (*ER*, iii, 699). In addition, the abbey was given 7s. to buy spices, and 13s. 3d. was paid for wages to boys of king's court (*Ibid*, 700-1).

<sup>387</sup> *RMS*, i, no. 826.

<sup>388</sup> *Registrum de Dunfermelyn*, no. 163; Duncan, *Scotland*, 136.

<sup>389</sup> For Dunfermline see *RMS*, i, nos. 454, 463-5, 467, 490, 494, 816, 819, 825, 834. For Inverkeithing see *Ibid*, nos. 482, 493, 538, 592.

<sup>390</sup> For the interment of Queen Euphemia Ross see *Chron. Bower*, ix, 137; R.K. Marshall, *Scottish Queens 1034-1714* (East Linton, 2003), 42-5; John Randolph, earl of Moray, the first husband of Queen Euphemia was killed at the Battle of Neville's Cross in 1346 (Penman, *David II*, 136).

On 14 August 1390 Robert III was crowned over four months after the internment of his father on 25 April 1390.<sup>391</sup> The delay may have been caused by a controversy about whether John, earl of Carrick (Robert III), was suitable to be king.<sup>392</sup> Although Robert III succeeded to the throne in 1390, his authority during his reign was fragile. During at least ten years of his sixteen year reign, he was displaced by guardians and lieutenants appointed and controlled by the parliament and the general councils. In particular, the influence of Robert earl of Fife, later duke of Albany - who replaced his elder brother, the future Robert III, as guardian of the kingdom in December 1388 and kept his guardianship until 1393, and remained a rival of Robert III throughout the king's whole reign - made it clear that Robert III could not exercise his full kingship.<sup>393</sup>

The king's unstable authority may have mirrored relatively fewer acts issued during his office. While there were 397 extant acts issued during the reign of his father, 271 acts were issued during the period of Robert III's office and remain extant. Although it should be considered that the period of his reign is four years shorter than his father's, relatively fewer acts were issued. Concentration of kingship (or guardianship) in geographical terms was similar to that of his father, whose kingship had focused on three regions such as Edinburgh, Perthshire and the Stewart's old lands. During Robert III's reign, 68 acts were issued in the 'Stewartry' and Firth of Clyde, 108 acts in Edinburgh and Linlithgow, and 67 acts in Perthshire.<sup>394</sup>

---

<sup>391</sup> *Chron. Bower*, viii, 3.

<sup>392</sup> Carrick abandoned his Christian name and began using the 'royal' name Robert III about when he became a king (Boardman, *The Early Stewart Kings*, 174-7). In fact, he had a right to succeed the throne as an heir, which had been guaranteed by the parliaments of 1371 and 1373. However, it was declared that he was not fit to carry out a role as a lieutenant by the three estates in December 1388 because of his infirmity. Therefore, when Robert II died, it was reasonable that John's suitability to succeed the crown would raise controversy (*Ibid*, 173-6). For Robert III's physical affliction see *Chron. Bower*, vii, 443. The *Exchequer Roll* demonstrates that he wanted the physician's help (*ER*, iii, 427) and the bailies of Dundee sent him vinegar when he was ill (*Ibid*, 306).

<sup>393</sup> Boardman, 'Coronations, Kings and Guardians: Politics, Parliaments and General Councils, 1371-1406', 114-8; Boardman, 'Robert III (1390-1406)', 109-11; Boardman, *The Early Stewart Kings*, 148-53, 305.

<sup>394</sup> Perth (42 acts), Scone (20), Edinburgh (53), Linlithgow (55). Dunfermline (15), Stirling (8) (*Ibid*, 284-5). It is impressive that 55 acts were issued at Linlithgow. In particular, the port at Blackness in Linlithgow was a

During the reign of Robert III Scone was attractive to the crown as 20 acts were issued there. Apart from parliaments at Scone, at some point from March 1391 to 31 January 1392, Robert de Logi, a canon of Scone, received £5 and was requested to pray for the souls of the king, his parents, his successors and predecessors.<sup>395</sup> In January 1392 the sum of £96 6s. 8d. was spent at Scone. Since the expense was paid under the guardianship of Fife,<sup>396</sup> it is possible that the cost did not relate to the Mass for the king's predecessors, successors and himself.<sup>397</sup> The king stayed there on special occasions like his birthday in 1400 when £22 16s. 4d. was spent there.<sup>398</sup>

As mentioned above, Paisley Abbey was a burial site of the Stewarts. However, just three acts regarding patronage of lands to the abbey were issued by Robert III.<sup>399</sup> These acts would have been issued in memory of Robert III's ancestors. Although fewer grants were given to the abbey during the reign of the king, he chose the abbey as his burial place. On 4 April 1406 Robert III died in the castle of Rotheasy on the Isle of Bute. From there his remains were moved to Paisley Abbey,<sup>400</sup> which was the burial place of the Stewarts, rather than his father's burial site, Scone Abbey, or Dunfermline Abbey, in which his wife was buried in 1401. He seems to have had antipathy against a splendid funeral rite, and therefore, wanted to be interred with a relatively simple funeral ceremony. It may have mirrored the fact that the *Exchequer Rolls* mentions nothing concerning his burial with the exception of the

---

crucial transport place for moving cargo to the centres of the Stewarts' lordship from the east coast (Boardman, 'Robert III (1390-1406)', 84-5).

<sup>395</sup> *ER*, iii, 307.

<sup>396</sup> The *Exchequer Roll* demonstrates that the final payment for Albany's pension for his Guardianship was carried out in February 1392 (*Ibid*, 317); *RMS*, i, nos. 868-9.

<sup>397</sup> *ER*, iii, 317.

<sup>398</sup> *Ibid*, 495, 509.

<sup>399</sup> The abbey were granted the lands in Renfrew, Air (Ayr), Roxburgh, Peebles on 5 April 1396 around the date of death of Walter Stewart, Robert III's grandfather (d.9 April 1326) (*RMS*, i, no. 1728); the lands of Thornley in the barony of Renfrew and other lands on 18 April 1404 around the date of Robert III's death (d.19 April 1390) (*Ibid*, i, nos. 1826-7).

<sup>400</sup> *Chron. Bower*, viii, 63; *Chron. Wyntoun* (Laing), iii, 98.

payment of 40s. to the abbey '*pro exequiis domini regis defuncti faciendis*' given eighteen years later by James I.<sup>401</sup>

Although he may have intended to have a simple burial rite, and in a similar vein he perhaps disagreed with the splendour of the religious houses, Paisley Abbey received less patronage, given the significance of the abbey as the burial site of the king's ancestors and the king himself. Less patronage from the crown to the abbey may have related to Robert III's weak kingship. Since for many years of his reign guardians and lieutenants governed the kingdom, regardless of the king's affection for Paisley Abbey, there was a possibility that the abbey did not draw the attention of guardians and lieutenants. In fact, the burial places of the guardian and the lieutenant indicate that the abbey was not attractive to them. For example, on 25-27 March 1402 David duke of Rothesay, who exercised his power as a lieutenant from 1393 to 1401, died in the tower of Falkland, and was buried at Lindores.<sup>402</sup> Obviously David wanted to be buried neither there, nor presumably at Paisley Abbey. The interment of another guardian, Robert duke of Albany and earl of Fife, at Dunfermline in 1420 indicates that he was more interested in Dunfermline Abbey than Paisley Abbey.<sup>403</sup> Alongside the duke of Albany's burial at Dunfermline, Queen Annabella Drummond was also buried at Dunfermline in 1401.<sup>404</sup> Given Queen Annabella's strong influence on Prince David, her attitude on Dunfermline may have been expressed in the name of the lieutenant. It can also be suggested that the lordship of Albany earl of Fife, who was a rival of Robert III throughout the whole reign of the king, blocked the crown's access to Dunfermline during the reign of Robert III.

---

<sup>401</sup> *ER*, iii, xcvi and iv, 391.

<sup>402</sup> *Chron. Bower*, viii, 39.

<sup>403</sup> *Ibid*, 132-5; *Chron. Wyntoun* (Laing), iii, 99-101.

<sup>404</sup> *Ibid*, 81; *Chron. Bower*, viii, 37.



In fact, Annabella's affection for Dunfermline Abbey is shown by her choice of Dunfermline as a place for the delivery of her son James in 1394.<sup>405</sup> The *Exchequer Rolls* demonstrates several acts of patronage to Dunfermline Abbey. In 1391 John de Torry (1388-1409) abbot of Dunfermline was confirmed an annuity from the fermes of Edinburgh, which had been ordered by Robert II in 1373.<sup>406</sup> From 1395 the abbot received £2 as an annuity from fermes of Haddington.<sup>407</sup> As mentioned above, the grant of £8 to the chaplain of St Margaret in Edinburgh castle was paid in 1393, 1395 and 1396.<sup>408</sup> Dunfermline Abbey took the confirmation of the patronage of the kirk of Inverkeithing, and the great customs of Inverkeithing, Musselburgh, Kirkcaldy and the Queensferry by the charter issued around 1399<sup>409</sup> when the kingdom was governed by David duke of Rothesay. In this point, the issue of the acts to Dunfermline Abbey may have been influenced by David's mother, Queen Annabella. Moreover, Robert Stewart earl of Fife, who was created duke of Albany in 1398, also showed his patronage to Dunfermline. When Fife as guardian governed the kingdom in 1392, the sum of £9 18s. 4d. was spent for the residence of the Fife himself or Robert III at Dunfermline.<sup>410</sup> In 1392 Fife visited Dunfermline several times, on 22 April, 16 October and 9 November (close to the feast of St. Margaret, 16 November).<sup>411</sup> As lay witnesses of royal acts issued at Dunfermline during the reigns of Robert II and III demonstrate - recorded on the acts only issued between 1391 and 1393, the period which corresponded with the moment of the guardianship of Robert Stewart earl of Fife (1388-1393) -, Fife was named as lay

---

<sup>405</sup>Balfour-Melville, *James I*, 281-3. £5 was spent by the queen at that time (*ER*, iii, 342). Apart from James, Queen Annabella had two more sons and four daughters: David (b. 1378) duke of Rothesay; Robert who died in infancy; Elizabeth who married to James Douglas, first Baron Dalkeith; Mary who married to first George Douglas, 1st Earl of Angus, secondly, to Sir James Kenney of Dunure; thirdly, to William, lord of Graham; and fourthly, to Sir William Edmonston of Duntreath; Egidia who died in infancy; Margaret, married Archibald Douglas, 4th Earl of Douglas (*ER*, iv, clxxi-clxxv; A. H. Dunbar, *Scottish Kings: a revised chronology of Scottish history, 1005-1625* (Edinburgh, 1906), 179-80; Michael Brown, *James I* (East Linton, 2000), 25).

<sup>406</sup> Annually £5 was paid (*Ibid*, 259, 304, 332, 364, 448, 479, 555, 577, 603, 635, 442 (£10, 1397)).

<sup>407</sup> *Ibid*, 365, 391, 418, 447, 501, 635 (£12, 1405).

<sup>408</sup> *Ibid*, 321, 352, 380.

<sup>409</sup> *RMS*, i, App. ii, no. 1891.

<sup>410</sup> *ER*, iii, 290. It is not sure whether Albany as a Guardian or Robert III resided there at that time.

<sup>411</sup> *RMS*, i, nos. 846, 855, 856, 862, 864, 870, 871.

witness, along with Archibald Douglas, 3rd earl of Douglas and lord of Galloway, who was a political ally of Fife, and James de Douglas, lord of Dalkeith, Thomas de Erskine and Alexander de Cockburn, whose roles were crucial in the border skirmishes of 1388.<sup>412</sup> That Fife was one of the centres of Albany earl of Fife's lordship and he chose Dunfermline Abbey rather than Paisley Abbey as his burial site lead us to understand his patronage of the abbey. Considering these circumstances, therefore, patronage to Dunfermline Abbey during the reign of Robert III may have mirrored the affection of Albany, as earl of Fife, and that of Queen Annabella - her first two children named David and Margaret, and the queen may have used Margaret Logie's empty tomb for herself as discussed in Chapter Three - for the abbey.

As mentioned above, Barbour said that the ancestors of the Stewarts came from the Britons in genealogical terms, which Barbour seems to have largely accepted as Robert II's view on the history of their family without question.<sup>413</sup> Inventing the long history of his family may have increased the suitability of Robert II to succeed to the throne. In addition, he could be depicted as an heir of the Britons, who had reclaimed to take political control of the entire Britain.<sup>414</sup> In fact, it was Queen Margaret who was a crucial figure to make the history of English royal family relate to the Scottish royal line. At first glance, since St Margaret had an Anglo-Saxon genealogy, the early Stewart kings, who were eager to be shown as successors of Brutus, king of Britain, may have had interest in the saint. However, since the early Stewart kings needed to have their own genealogy to secure the legitimacy as successors to the throne, the kings would have thought that their connection with the Canmore dynasty and its successor, the Bruce dynasty, should be cut. To do so, they wanted presumably to open a new era. Therefore, they did not need to stress the relationship with the

---

<sup>412</sup> *Ibid*, nos. 816, 819, 825, 834, 846, 855, 856, 862, 864, 870. For Archibald Douglas see Boardman, *The Early Stewart Kings*, 174; A.D.M. Barrell, *Medieval Scotland*, 147-8. For James de Douglas see Thomas de Erskine and Alexander de Cockburn, Boardman, *The Early Stewart Kings*, 142.

<sup>413</sup> Boardman, 'Late Medieval Scotland and the Matters of Britain', 54.

<sup>414</sup> *Ibid*, 60.

previous dynasties through invoking St. Margaret who was a symbolic saint of the previous royal family, nor did Robert II need St Margaret's power for fertility and child birth.

However, it should also be noted that the early Stewart kings named some of their offspring after the members of the Canmore dynasty. Robert II called three of his children Alexander (d.1405), Margaret (d.1387) and David (d.1389-90).<sup>415</sup> Of the offspring of Robert III, David duke of Rothesay (1378-1402) and Margaret, wife of Archibald 4<sup>th</sup> earl of Douglas were named after the Canmore king and queen, or David II and Margaret Logie/Drummond. Given that Queen Annabella gave birth to James I at Dunfermline in 1394, and her other two offspring were named after David and Margaret respectively, it can be speculated that Robert III's two children, David and Margaret were also born at Dunfermline. From these facts and speculation, it might be said that Robert II (b. c.1316) and Robert III (born, c.1336) once had association with St Margaret in spiritual terms, although political motivation did not lead them to Dunfermline.

---

<sup>415</sup> There were also other offspring called John, Robert, Walter, Marjorie, Elizabeth, Isabella, Jean (I), Egidia, Jean (II) (Boardman, *The Early Stewart Kings*, 41).

## **(11) Conclusion**

On the political level, through Dunfermline Abbey and the cult of St Margaret, the kings could display dynastic continuity and sacral kingship to counter the internal dynastic challenges and the external rivalry of England. Dunfermline was also a tactical place to expand monarchs' influence over the central and southern parts of the kingdom. Alongside these political purposes, the crown could secure moral and spiritual power through their dedication to St Margaret and Dunfermline Abbey. On a personal level, the kings displayed devotion to the abbey out of their genuine piety to earn salvation of their souls, and their desire for securing the aid of St Margaret' sark for royal succession. On the other hand, as a monarchy, the kings could employ the spiritual and moral power of Dunfermline for expanding their secular power against internal and external rivals.

The configuration of Scottish royal patronage to Dunfermline Abbey was determined by a variety of circumstances, which each king encountered. David I's favour to Dunfermline would have been derived from his genuine piety and his memory of his parents and brothers, who were buried there. In addition, as his predecessors did, David would have considered Dunfermline Abbey as his political centre to expand his authority towards the southern part of his kingdom against internal dynastic rivals and England. It is natural that David was pious and had affection for the abbey, because he was the son of St Margaret and was influenced by his sister, Queen Matilda, whose piety was considered to be equivalent to that of St Margaret. To the abbey, David was the most significant patron in its history, because he stabilized the status of the abbey as a royal monastery, and laid a foundation for the abbey to be a royal mausoleum. Malcolm IV expressed his honour to David, his immediate predecessor. Malcolm IV's generosity to Dunfermline Abbey would have been out of his admiration for David rather than other reasons. To Malcolm IV, the abbey may have been considered as the shrine of David as well as St Margaret. William seems to have been interested in

Dunfermline in his early reign, because he would have seen his brother's, Malcolm IV's veneration of David and Dunfermline. However, after Arbroath Abbey dedicated to St Thomas was founded in 1178, Dunfermline Abbey could not draw William's affection back, in spite of the translation of St Margaret's remains in 1180, which was presumably carried out by the monks of Dunfermline to meet the demand for more space, and maintain or promote the reputation of the abbey.

Alexander II's favourite religious house was Melrose Abbey. His affection for Melrose was derived from his genuine penance for the breach of his oaths to Melrose's St Waltheof as well as his political purpose to use the monks of Melrose Abbey as his representative to play roles of royal agency in the disputed border region, along with the wealth of the abbey secured from foreign trade. However, he recognized the significance of royal saints as propaganda. He thus made an effort to secure the canonisation of St Margaret, which was probably influenced by the canonisation process of St Edmund and Henry III's reconstruction project at Westminster Abbey rather than his genuine affection for St Margaret. Shortly after Alexander III was inaugurated in 1249, St Margaret was allowed to be canonised, and then the translation of the saint took place in 1250/1. In spite of this, in his early reign Alexander III was interested in English saints and English cults, because of his close relationship with Henry III. However, he changed over time. His attention was turned to Dunfermline Abbey in the 1270s. The shift seems to have been influenced by his wife, Queen Margaret, who was devoted to St Margaret. In addition, the English monarchs' and French kings' projects at Westminster and St Denis respectively led Alexander to recognize the significance of the royal saint and the royal cult. Apart from Alexander II and III's personal favour to religious communities, from the point of view of Dunfermline's prosperity, the official canonisation of St Margaret and the following translation in the mid-thirteenth century obviously led the abbey to its peak.

John Balliol's reign was too short to employ St Margaret and the royal mausoleum in order to secure his legitimacy. Furthermore, the early death of Margaret the Maid of Norway and the possible wish and effort of previous kings, Alexander II and III, and monks of Dunfermline to make the abbey a coronation church probably related to John's hesitation to demonstrate his dedication to Dunfermline so as to raise his authority and legitimacy. However, the treaty meeting for the Franco-Scottish alliance was held at Dunfermline in 1296 indicating that Dunfermline was still considered a significant place in political terms. The succession crisis and the wars would have disrupted the celebration of special anniversaries. For example, in 1293 the 200<sup>th</sup> anniversary of Margaret's death, and in 1300 the 50<sup>th</sup> anniversary of St Margaret's translation and the 150<sup>th</sup> of the abbey's consecration could not be celebrated splendidly. On the other hand, Edward I of England, who had Scotland under his control in 1303-4, also showed his veneration to St Margaret. Since St Margaret was a Saxon princess, the English king seems to have also considered St Margaret from a genealogical point of view.

Robert I was aware of the significance of the cults of saints as propaganda. He employed Scottish and local saints and even Thomas Becket to enhance national identity and to raise national pride. Since Becket was a symbol of opposition to the English king, Robert's invocation of Becket and his patronage to Arbroath Abbey was natural while he was resisting the English. In the same vein, Robert gave his patronage to Melrose Abbey, in which Robert's heart was buried at his request after its returning from the Crusade, and which was located on the border so that the abbey was a key military centre during the wars of Independence. Since Robert had a lack of legitimacy to be a king, he needed to demonstrate his close association with the Canmore kings. In addition, he was perhaps supposed to emulate Edward, who made a royal mausoleum at Westminster. From these reasons, he gave grants to Dunfermline Abbey and further developed Dunfermline as a royal mausoleum.

As Robert did, David II also paid attention to Becket and Arbroath Abbey. However, his approach to the saint was different from that of Robert. David II used Becket in a pro-English, anti-Stewart agenda. David's carrying the relics of St Margaret at the battle of Neville's Cross meant that he stressed the fact that St Margaret was a Scottish queen who would protect the Scots. However, the Scots defeat at the battle and the loss of a 'Black Rood' or other cross indicate that St Margaret was overwhelmed by St Cuthbert who was a patron saint of Durham, which probably led David to lose his faith in St Margaret. In addition, in the latter part of his reign his infertility might have caused him to lose his interest in the saint and Dunfermline Abbey. That is, in order to have his heir he would have invoked St Margaret who had been believed to have powers relating to childbirth, but his wish was not accomplished. In spite of this, the interments of David's close relatives and his major followers at Dunfermline Abbey mean that the status of the abbey as a royal mausoleum was still stable or sustained.

The early Stewart kings, Robert II and III, concentrated on Scone Abbey and Paisley Abbey rather than Dunfermline. Since they opened a new dynasty, they did not demonstrate their association with the Canmore kings, by giving their devotion to Dunfermline Abbey and St Margaret. Instead they focused on the regions which they were from. However, the number of extant acts issued at Dunfermline during the reign of Robert II and III demonstrates a relatively high percentage (2.8%, 5.5%),<sup>416</sup> which might relate to (Robert II's) Queen Euphemia, whose first husband was John Randolph, earl of Moray, and (Robert III's) Queen Annabella's affection for Dunfermline as well as the interest of Albany in Dunfermline, whose power was based Fife and Menteith and who ruled Scotland as Regent after the death of his brother King Robert III.<sup>417</sup> Both queens and Albany were buried at

---

<sup>416</sup> See Table 2.

<sup>417</sup> Boardman, *The Early Stewart Kings*, 148-53, 305.

Dunfermline. Yet the abbey did not function as a royal mausoleum to the Stewarts. After 1420, no member of the Stewart royal family was buried there.

From the monks' of Dunfermline perspective, the enhancement or the restoration of status and reputation of the abbey would have been the most important matter. Whenever the interest of the crown, which was the most significant patron to the abbey in financial and psychological terms, turned away from Dunfermline Abbey to other religious houses, they attempted to draw the crown's interest back to Dunfermline. For example, the 1180 translation was in part intended as a preliminary warning to shift William's favour away from Arbroath. Dunfermline Abbey also had a close relationship with the laity. Although no extant lay/non royal act for Dunfermline Abbey during the reigns of David I and Malcolm IV remain, there are surviving acts of lay patronage to the abbey, for example, from the reign of William I and the years of 1228, the 1230s, 1317, 1339, and the burials of Matilda Bruce and Christian Bruce in 1353, 1357 when Dunfermline did not or could not receive royal patronage. This lay patronage, which was largely centred on the regions of west Fife close to Dunfermline,<sup>418</sup> presumably derived from the purpose of the monks of Dunfermline to boost the status of the abbey or survive in difficult times. The appeal of the abbot and convent of Dunfermline even to English King Edward I in order to have a market and Edward's grant of privilege to have a weekly market to them in 1304 and 1305 could also be understood in this context.

In addition, since lay witnesses of royal acts were generally significant persons in the regions where the acts granted lands, the lay witnesses to the royal acts for Dunfermline could give us an insight into which nobles were important to Dunfermline, and presumably had relationships with Dunfermline. The geographical distribution of lay witnesses on the royal acts for Dunfermline, in particular, issued during the reigns of David I, Malcolm IV and

---

<sup>418</sup> See Map 7.



William largely corresponded to that of lands the kings granted to the abbey. In other words, Dunfermline perhaps had association with or was supported by laymen of the regions in which the lands the kings granted to Dunfermline were located, although from Alexander II the lay witnesses on the royal acts for Dunfermline did not demonstrate this pattern. Also worthy of note is that earls of Fife during the reigns of Alexander II and III, Robert I, and David II were seldom named on the royal acts for Dunfermline, with the exception of the involvement of the earl of Fife to Dunfermline such as the homage of Malcolm earl of Fife to Robert de Kaledelth abbot of Dunfermline in 1250/1; the homage of Duncan earl of Fife at the request of Abbot Ralph to the abbey in 1316; and a few cases of the earl of Fife being named on the royal acts issued at Dunfermline. However, since earls of Fife built up their actual earldom and lordship on the east Fife,<sup>419</sup> Dunfermline Abbey was situated to the west of the actual earldom of Fife. Thus, it is not strange that earls of Fife were rarely named on the royal acts for Dunfermline. Or, given the homage of Fife earls to Dunfermline as mentioned above, it cannot rule out that the earls were major patrons of Dunfermline and buried at the abbey but the evidence has not survived.

The attempt of the monks of Dunfermline to enhance the status of the abbey and draw the kings' affection for them can be seen in the layout of the cartulary, *Registrum de Dunfermelyn*.<sup>420</sup> The layout of the original version is different from the transcript version, which was edited by the Bannatyne Club in the nineteenth century, as already noted. As far as the royal acts to Dunfermline recorded in the seventeenth century original manuscript are concerned, the acts issued during the reigns from David I to Alexander III are placed in the first part with in a chronological order of kings and embellished with red and blue ink. In addition to this part, the acts issued by James II were located almost together. On the other hand, the acts in the cartulary issued by the kings Robert I, David II, Robert II and Robert III

---

<sup>419</sup> McNeill and MacQueen eds., *Atlas of Scottish History to 1707*, 186.

<sup>420</sup> NLS. Adv. MS. 34. 1. 3A.

seem to be inserted and added at random.<sup>421</sup> Therefore, the original cartulary may have been rewritten twice. The first phase dating back to David I seems to have been written during the reign of Alexander III perhaps as a ceremonial display copy for the high altar. Since the last acts of Alexander III in the *Registrum de Dunfermelyn* was issued in probably 1278,<sup>422</sup> the manuscript was probably first redrafted at least after 1278 when Alexander III's interest turned to Dunfermline Abbey. This 'Ancient' material embellished with red and blue ink focused on the kings' acts.

On the other hand, the second phase, which was presumably written during the reign of James II (1437-1460), was a more practical working copy, inserting and adding acts to the 'Ancient' material. In this phase, the acts of Robert I were relatively fewer, compared to those of James II.<sup>423</sup> The fact leads to speculation that the fourteenth-century material was copied into the display version, coinciding with the construction of the new Lady Chapel and the burials of Bruce family and Bruce's crucial followers, but some of the materials, including lay gifts were presumably lost or excised. The reign of James II overlapped a fuller period of reconstruction at Dunfermline Abbey under the control of Abbot Richard de Bothwell (1444-68), including the reconstruction of the north-west tower, the greater part of the west bays of the north arcade and their upper part; the addition of the porch over the north doorway at the nave; and the replacement of the vaulting in the three western bays of the north aisle.<sup>424</sup> In other words, the moments when the cartulary was presumably copied/edited overlapped the periods when the abbey prospered. This correspondence apparently reflected the aim of the monks of Dunfermline to draw or keep the crown's affection for the abbey. Also worthy note is that the editing/recasting of the cartulary at the moments led the monks to

---

<sup>421</sup> See table 3.

<sup>422</sup> *Registrum de Dunfermelyn*, no. 87; *RRS*, iv, no. 115.

<sup>423</sup> NLS. Adv. MS. 34. 1. 3A. fols. 51, 54-6, 61-2, 73, 95.

<sup>424</sup> Fawcett, 'Dunfermline Abbey Church', 52.

focus on the royal patronage, thus be less interested in non-royal laity's, which presumably caused the loss of much evidence, particularly that of regional and wider elite laity.

Table 2. Location of Royal acts (extracted from *The Charters of King David I*; *RRS*. i, ii, iv, v, vi; *Handlist* i, ii; *The Early Stewart Kings*, 92, 284.; *RMS*. i. )

	Total number of extant acts	Number of extant acts issued at Dunfermline	Number of extant grants issued to Dunfermline
David I	216	12 (5.5%)	29 (13.4%)
Malcolm IV	213	7 (3.2%)	14 (6.5%)
William I	590	12 (2%)	24 (4%)
Alexander II	396	2 (0.5%)	8 (2%)
Alexander III	330	1 (0.3%)	7 (2.1%)
John	65	1 (1.5%)	1 (1.5%)
Robert I	569	5 (0.8%)	15 (2.6%)
David II	518	7 (1.3%)	7 (1.3%)
Robert II	397	11 (2.8%)	0
Robert III	271	15 (5.5%)	1 (0.6%) ( <i>RMS</i> . i, app. 2. 1891)

Table 3. The layout of the manuscript, *Registrum de Dunfermelyn* (NLS. Adv. MS. 34. 1. 3A; printed version (Bannatyne Club; Edinburgh, 1842))

Manuscript number	Entry number (of Bannatyne edition)	King
⋮	⋮	⋮
fol 41	3-34	David
fol 43	387	David II
fol 44	1, 36	David, Malcolm IV
fol 45	49	Malcolm IV
fol 46	35	
fol 47	51	William I
fol 48	72	
fol 49	50, 73	
fol 50	73, 75-80, 74	William I, Alexander II
fol 51	364, ....	Robert I
fol 52	82	Alexander III
fol 53	89, 81	
fol 54	345, 346	Robert I
fol 55	363, 361, 365	
fol 56	356, 357, 358, 375	Robert I, David II
⋮	⋮	⋮
fol 61	..... , 355	Robert I
fol 62	355, 385, 333, .....	Robert I, David II
fol 63	406, 407, 408, 409	

fol 64	411, 412, 410, 414	James II
fol 65	414, 416	
fol 66	416, 422	
fol 67	420, 421, 419, 418, 405, 338	James II, Robert I
fol 68	... , 425-8	James II
fol 69	424	
fol 70	424, 440	
fol 71	433, 451	
⋮	⋮	⋮
fol 73	340	Robert I
fol 74	429, 430, 431	James II  James II
fol 75	444, 423	
fol 76	436, 432, ...	
fol 77	..., 438, 439	
fol 78	434	
fol 79	..., 383	David II
fol 80	382, 383, 400, 410	David II, James II
fol 81	410, 444, 443, 344	James II, Robert I
fol 82	442, 445	James II
fol 83	447, 446, 448	
fol 84	449, 450, 453	
fol 85	453, 455, 456	
fol 86 - 90		James III
fol 91	452	James II
fol 92	454	

fol 93-4		James III
fol 95	367, 369, 362, 363, 390	Robert I, David II
fol 96	390, 391, 394,....	David II
fol 97	....., 432	James II
fol 98-99		James III

Map 7. The distribution of extant nobles' patronage to Dunfermline Abbey

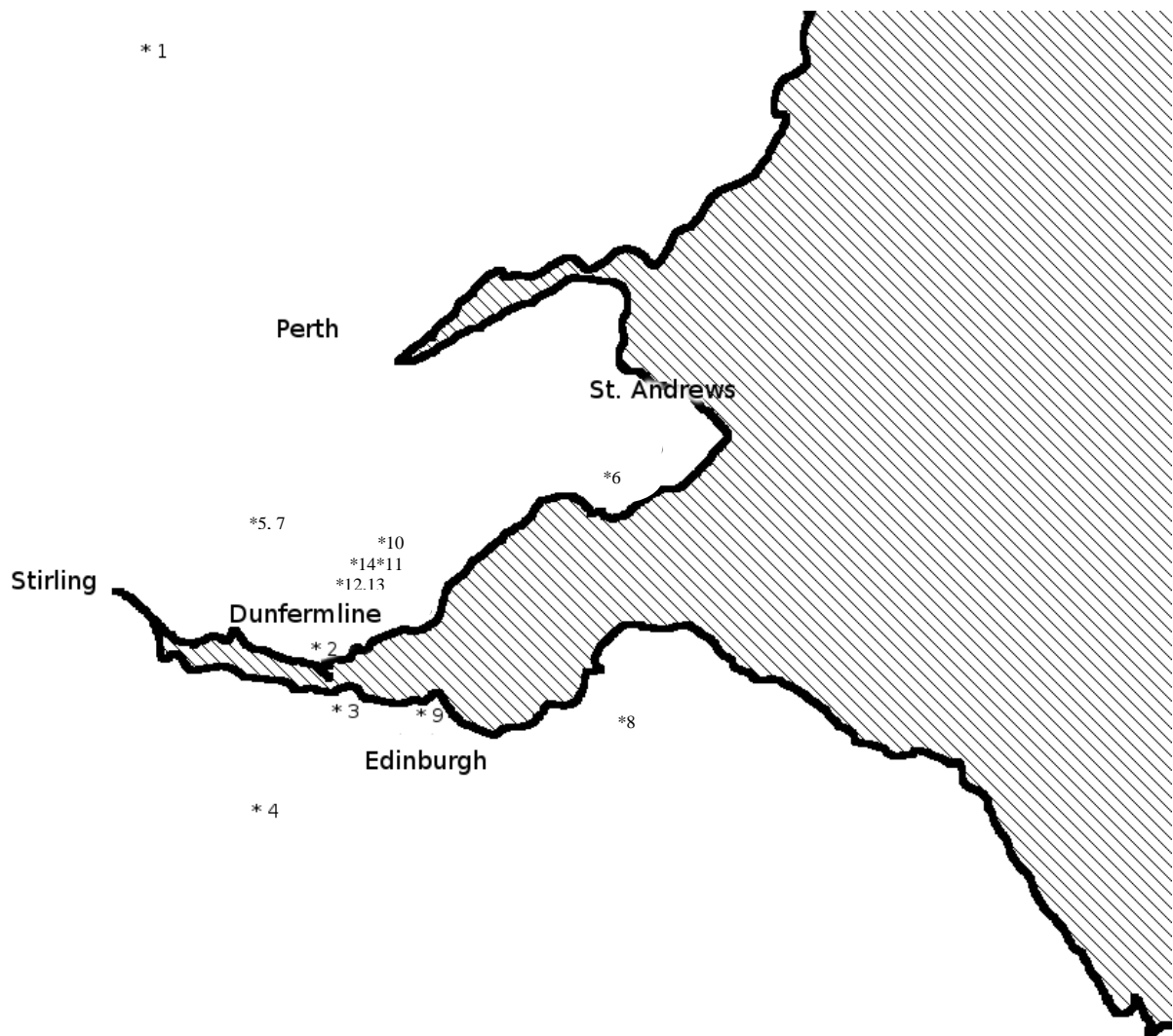

- 
1. Moulin 2. Inverkeithing 3. Cramond 4. West Calder 5. Cleish 6. Abercrombie  
7. Cleish and forest of Outh 8. Haddington 9. Leith 10. Kinglassie 11. Cluny  
12. Wester Beath 13. Beath Waldeve 14. Newlands



### **Chapter 3. The Liturgical and Devotional Space of Dunfermline Abbey**

#### **(1) Introduction**

The main purpose of medieval church buildings was to host the Christian liturgy, that is, ‘the whole public worship of the Church, the Mystical Body of Jesus Christ, Head and members.’<sup>1</sup> For this purpose, church buildings were designed to adapt to liturgical practices. Consequently, all aspects of church buildings including the structure, size and decoration were determined by principles of liturgical performance. Liturgy means not only the performance conducted in the church by the churchmen/women but also various acts of religious devotion of the laity such as pilgrimage and the cult of relics/saints.<sup>2</sup> Since liturgy was carried out in church buildings, it is also natural that the performance of liturgy was inevitably influenced by the liturgical and devotional space, and *vice versa*. In other words, the liturgical/devotional space and the liturgical observances interacted with each other. Therefore, the development of the liturgical and devotional space should be examined from the point of view of its relationship with the liturgical practices. In this context, the starting point for developing an understanding of the liturgical/devotional space of Dunfermline Abbey is to examine the liturgy.

Unfortunately there are no extant documents relevant to the liturgy of the Scottish church, including the church at Dunfermline during the time of Queen Margaret and her sons. However, given the attempt of Queen Margaret and her sons to re-invigorate the Scottish church by bringing it into the mainstream religious culture of the Continental church, and the fact that the church at Dunfermline was a Benedictine priory/abbey, it is possible to suggest that the queen would have introduced the Benedictine liturgical observance into Scotland to

---

<sup>1</sup> J. O’Connell, *Church Building and Furnishing: The Church’s Way* (London, 1955), 7-9.

<sup>2</sup> Peter Draper, ‘Architecture and Liturgy’ in Alexander and Binski eds., *Age of Chivalry*, 83; Arnold William Klukas, ‘The Architectural Implications of the *Decreta Lanfranci*’ in R. Allen Brown ed., *Anglo-Norman Studies*, VI (Woodbridge, 1984), 149.

modify that of the native Scottish church. Above all, the liturgical observance brought into Dunfermline by Queen Margaret, Turgot and her supporters would have been affected by Archbishop Lanfranc of Canterbury's *Constitutions*. The *Constitutions* have been dated to c.1077, although a time window of after 1079 but before 1083 has also been posited as plausible.<sup>3</sup> Given the slow spread of knowledge alongside books at that time, it may be doubted that the *Constitutions* were circulated to Dunfermline at the end of the eleventh century or shortly thereafter. However, since Queen Margaret had a close relationship with Archbishop Lanfranc he might have sent a copy to Dunfermline Priory, which was a daughter house of Canterbury, in her lifetime or in the reigns of her sons. Moreover, the monks dispatched to Dunfermline by Lanfranc at the request of the queen might have had an opportunity to bring a copy of the *Constitutions* with them. That a son of Queen Margaret, King Edgar, also requested Archbishop Anselm to send monks from Canterbury to Dunfermline<sup>4</sup> may have been equally relevant to the introduction of the *Constitutions* into Dunfermline.

Over a period of time, however, the liturgy introduced into Dunfermline from Canterbury would have increasingly reflected the needs and priorities of the laity and their families, rather than purely a saint, scripture etc. For example, on the liturgical collects at Mass, the king, queen and their children were prayed for by name. A statute from the Synodal Statutes of the Diocese of Aberdeen in the thirteenth century indicates that:

in the celebration of Masses there should, besides those said in double feasts, be said five collects, one of the peace of the church, namely: 'We pray thee, Lord, to be pleased to accept the prayers of thy church, so that oppositions and all errors being made an end of, she may serve thee in untroubled liberty; through the Lord,' etc. Another for our lord the king, the queen, and their children, namely: O God, in whose hand are the hearts of kings; who art the comforter of the humble, and

---

<sup>3</sup> *The Monastic Constitutions of Lanfranc*, xxviii.

<sup>4</sup> Lawrie, *Charters*, no. 25.

the strength of the faithful, and the protector of all who hope in thee; grant to our king and queen and their children.....'<sup>5</sup>

In addition, a constitution of David de Bernham, bishop of St Andrews, in 1242 also suggests that one of the collects at Mass was for 'our king and the queen and their children.'<sup>6</sup> These instructions for prayers for members of the royal family, who were members of the lay elite, to be placed in the Mass further emphasise and reflect a significant shift of liturgy toward the honouring of secular figures in an ecclesiastical space.

With respect to the introduction of the *Constitutions* into Dunfermline, exploring the liturgical observance set out within the document makes it possible to speculate what kind of liturgy had been imported and performed in the church at Dunfermline. Since the *Constitutions* of Lanfranc were based on the Rule of St Benedict, it is helpful to consider the liturgy of the Benedictine Order before scrutinising the *Constitutions*. In the Rule of St Benedict, the most crucial event was the *Opus Dei*, the Divine Office, which was intended to follow the *horarium*. The first and longest service of each day was Nocturns, which is known now as Matins and sometimes called midnight prayers or vigils. At sunrise, the next Office - Lauds - was performed. During the day time, while the monks carried out their daily works, they had to attend four further services. The first one was called Prime, which was considered to be the prayer for a new day. The next three Hours consisted of: 'Terce, in the middle of the morning'; and 'Sext, at noon with lunch'; 'None, in mid-afternoon'. The Hour of Vespers followed at sunset. Finally, a day was ended with a bedtime prayer called Compline.<sup>7</sup>

As far as the *horarium* and its liturgy are concerned, all the above mentioned were performed in the time of St Benedict, with the exception of a Mass on Sundays and major feasts. In the eleventh century the established liturgy added many things such as the

---

<sup>5</sup> *Statutes of the Scottish Church 1225- 1559*, ed. David Patrick, 40-1.

<sup>6</sup> *Ibid*, 60-1.

<sup>7</sup> David Payne-Carter, 'Procession and the Aesthetics of Everyday Life of a Benedictine Monastery', *The Drama Review*, vol. 29 (3) (1985), 43; *The Monastic Constitutions of Lanfranc*, xxi.

Chapter's daily meeting for discipline and business; the High Mass; the Morning Mass; and extra psalms, prayers and minor Offices. In this context, Lanfranc's *Constitutions* in terms of a liturgical directory indicated the monastic *horarium* and devotional practices as follows. The threefold prayer (*Trina Oratio*), which was a common devotion in monastic houses by the beginning of the eleventh century, was performed three times a day: before Matins, before Terce in the winter or Prime in the summer, and after Compline. The first *Trina Oratio* was followed by recitation of the last 32 Psalms (Ps. 119-150) in the winter or the Gradual Psalms (Ps. 119-33) in the summer. After Matins and the *Psalmi familiares*, which were chanted for friends or benefactors of the monastery, the office of the dead was recited. Lauds was prayed with the *Psalmi familiares*, Suffrages in the winter - additionally the Office of All Saints and the Dead in the summer. Prime was recited with the *Psalmi familiares*, the seven penitential psalms (Ps. 6, 31, 37, 50 (51), 101, 129 (130), 142 (143)), and the Litany of the Saints. In the winter, at the Terce and the Morrow Mass, the monks were present at the Chapter. After the Chapter *Verba mea* (Ps. 5) and other psalms (Ps. 6, 114, 115, 129) were chanted; the gospel of the day and a sermon followed. At Sext, *Psalmi familiares* were recited, and on Wednesday and Friday the Procession was performed prior to the celebration of High Mass. On the other hand, the daily *horarium* of the summer was different from that of the winter. In the summer, the Morning Mass was followed by the Chapter, and then Terce, High Mass, and Sext. After High Mass in the winter or Sext in the summer, None was carried out. At Vespers, *Psalmi familiares* were recited; Suffrages, the Office of All Saints, the Office of the Dead and Matins of the Dead followed. The Liturgy and the Hours of the day were completed with Compline.<sup>8</sup> In addition, Lanfranc's *Constitutions* described what happened on specific feast

---

<sup>8</sup> *Ibid.*, xxii-xxv. For Matins and Laud see *Ibid.*, xxi, xxiii, 4, 12, 14, 16-18, 20, 22, 42, 70, 72, 78, 84, 94, 98, 100, 104, 112, 114, 118, 124, 142, 144, 186, 220. For Prime see *Ibid.*, xxi, xxix, 6, 12, 14, 16, 18, 26, 32, 58-60, 64, 74, 86, 90, 98, 122, 136, 180. For Terce see *Ibid.*, xxi, xxiv, 6, 18, 22, 24, 28, 32, 34, 44-6, 60, 74, 78, 80, 82, 86, 90, 96, 98, 120, 136, 140, 188. For Sext see *Ibid.*, xxi, xxiv, 8, 18, 28, 30, 46, 74, 78, 80, 82, 86, 90, 92, 216. For None see *Ibid.*, xxi, xxiv-xxv, 8, 26, 32, 40, 46, 60, 66, 72, 78, 80, 82, 84, 86, 88, 90, 92, 96, 98, 138-40, 188,

days. For instance, he described the detail of liturgy performed on Christmas, Ash Wednesday, Palm Sunday, Good Friday, Holy Saturday, Easter day and week and so on.<sup>9</sup> These liturgical routines also meant that monks needed a large, open space with multiple altars.

It seems that by 1100 the *Constitutions* had been distributed to at least the Benedictine religious houses at Durham, St Albans, St Augustine's of Canterbury, Rochester, Westminster,<sup>10</sup> and probably to other places including Dunfermline. However, this does not mean that the *Constitutions* brought liturgical uniformity. All Benedictine communities in England exercised a certain degree of autonomy with regard to liturgical acts within the main structure of religious practices.<sup>11</sup> Therefore, it is no wonder that some churches which took the *Constitutions* also kept their peculiar liturgical observances alongside the influence of Lanfranc. This independence concerning liturgical practices was maintained until the Fourth Lateran Council in 1215 declared two canons: canon 12 indicating that General Chapters should be held every three years; and canon 13 announcing that new orders were prohibited. These, in theory, could bring about religious uniformity, which could also cause the development of common observances to form in liturgical terms. However, in reality, even after 1215 Benedictine communities kept a certain degree of autonomy with regard to liturgical acts as well as in other ways.<sup>12</sup> For example, when John Salmon, bishop of Norwich made a visitation of Norwich Priory in 1308 his report records the low attendance of monks at the Offices - sometimes seven or eight monks out of purportedly sixty turned up in the

---

216. For Vesper see *Ibid*, 4, 12-14, 22, 24, 30-4, 42, 78, 84, 88, 90, 92, 94, 96-100, 104, 112, 122, 136, 138, 142, 144, 218.

<sup>9</sup> *Ibid*, 4-104.

<sup>10</sup> M. Gullick, 'The English owned manuscript of the *Collectio Lanfranci* (s.xi/xii)' in L. Dennison ed., *The Legacy of M. R. James* (Donington, 2001), 99-117; Richard W. Pfaff, *The Liturgy in Medieval England: A History* (Cambridge, 2009), 110; *The Monastic Constitutions of Lanfranc*, xxxi; T.A. Heslop, 'The Canterbury Calendars and the Norman Conquest' in Richard Eales and Richard Sharpe eds., *Canterbury and the Norman Conquest: Churches, Saints and Scholars 1066-1109* (London, 1995), 62-5.

<sup>11</sup> *The Monastic Constitutions of Lanfranc*, 76-8, 115, 183; Pfaff, *The Liturgy in Medieval England*, 168, 200-242.

<sup>12</sup> For the diversity of liturgy in English Benedictine houses after 1215 see Pfaff, 'Benedictine liturgy after 1215' in *Ibid*, 200-42.

choir - which related to their obligation for numerous private and votive Masses. Moreover, he notes the overcrowding of the Lady Chapel caused by too many lay people wanting to attend the Lady Mass and the necessity of the books on private altars being consistently maintained and ordered.<sup>13</sup> These points demonstrate that the priory kept its own way of performing services, which differed from that of the bishop. In this context, even though Lanfranc's description of religious observances and his liturgical directory would have influenced the liturgical performances of the church at Dunfermline, the observances of Dunfermline must have retained a certain individuality, as did those of other Benedictine houses.

In spite of the particular idiosyncrasies of an individual church in terms of liturgy, the liturgical observances discussed above were the essence of the liturgy conducted by the Benedictine order. Therefore, in general, the design of Benedictine buildings including the church at Dunfermline would be intended to accommodate the liturgical observances mentioned above. In contrast, changes to the liturgical space also led to alterations in liturgical practices. For example, the translation of tombs might be a typical occasion for this process. The translation of a saint's shrine produced one more shrine or station, that is, the new one, which affected the development of the cult of the saint. The establishment of altars, which was caused by liturgical and patronal demands, also influenced a change in terms of liturgical practices. The main purpose of these altars was to permit the veneration of the saint to whom the specific altar was dedicated, and to hold relics of the saint. Veneration of a saint and possession of the saint's relics created a virtuous circle. That is, the veneration of a saint accelerated the need for more relics. Simultaneously, getting more relics promoted the cult of the saint.<sup>14</sup>

---

<sup>13</sup> *Ibid*, 207-8.

<sup>14</sup> However, in some cases, such as the religious houses dedicated to 'St Michael the Archangel or the Holy Trinity, relics would not have been available, and therefore other relics would have to have been interred within

In the early centuries of the Church there was only one altar; however, from the sixth century onwards, side altars began to appear in addition to the high altar across Western Christianity. Although side altars became an essential part of the structure of major churches by the tenth and eleventh centuries, until the late thirteenth century it was rare that a church possessed more than 15 altars with the exception of a few major churches, such as Saint-Denis in Paris, which possessed 19 altars in 1140. In the later Middle Ages the increase of private Masses for the soul of the dead led to a need for more side altars in churches, particular for those of high status.<sup>15</sup> Dunfermline could certainly boast such status - it was one of major churches, the first Benedictine abbey in Scotland, the royal mausoleum and located in a royal burgh – and would therefore have needed to have more than 15 altars even before the late thirteenth century.

The tombs of a saint, the several stations created by the translation of tombs, and altars dedicated to saints were all central to the church structure, to the promotion of the cult of saints and in representing the status of the cult. In this context, this chapter will examine the liturgical/devotional space and its alteration at the church of Dunfermline in the context of the relationship with the liturgical practices, the development of the cult of St Margaret and the influence of the Scottish kings who were crucial patrons of Dunfermline Priory/Abbey.

---

the altar or the altars would have been consecrated without relics (Beth Williamson, 'Altarpieces, Liturgy, and Devotion', *Speculum*, vol. 79, no. 2 (2004), 355-6).'

<sup>15</sup> Justin Kroesen, 'Recentring Side Altars in Medieval Church Interiors: The Example of Late Romanesque Churches in Groningen' in Justine E.A. Kroesen and Victor M. Schmidt eds., *The Altar and its Environment 1150-1400* (Leiden, 2010), 147.

## **(2) The earlier church, c.1070-1124.**

In answer to your request, I am sending to you and your husband our dearest brother Goldwine, and two other monks, since he could not by himself fulfil all that should be done in God's service and yours. I ask earnestly that you should endeavour resolutely and successfully to complete the work you have begun for God and for your souls. And if you can or should wish to fulfil your work through others, we greatly desire that our brothers should return to us, because their services are needed by our church. But let it be according to your will.<sup>16</sup>

This is a statement of Lanfranc, archbishop of Canterbury (1070-1089), in a letter sent to Margaret. In addition, Turgot, Queen Margaret's biographer, states that shortly after her marriage to Malcolm at Dunfermline in 1070 the queen built a church there 'in honour of the Holy Trinity ... to serve a threefold purpose; it was intended for the redemption of the king [Malcolm III]'s soul, for the good of her own, and for securing to her children prosperity in this life and in that which is to come.'<sup>17</sup>

From these passages, it is confirmed that Queen Margaret, as Turgot mentioned, had founded the church at Dunfermline,<sup>18</sup> which inherited its dedication to Christ and the Holy Trinity from Canterbury. As Alison Binns indicates, the Holy Trinity as a subject of dedication became more important in the late eleventh century. In this respect, Margaret and Dunfermline also followed the trend. Five churches Christ Church at Canterbury (Benedictine), Norwich Cathedral Priory (Benedictine), the Church of Holy Trinity at York (Benedictine), Wallingford Priory in Berkshire (Benedictine) and Christchurch at Twynham (Augustinian), all dedicated to the Holy Trinity, were founded in the immediate post-Conquest period. The establishment of these five communities placed the Holy Trinity third highest in the ranking of dedications, following the Blessed Virgin Mary and St Peter.<sup>19</sup> During the first half of the twelfth century, a further ten monastic foundations dedicated to

---

<sup>16</sup> Lawrie, *Charters*, no. IX, and p. 236, quoted in Barrow, *The Kingdom of the Scots*, 173; *ESSH*, ii, 31-2.

<sup>17</sup> Turgot, *The Life of St Margaret*, 29.

<sup>18</sup> *Ibid*, 81.

<sup>19</sup> Binns, *Dedications of Monastic Houses in England and Wales 1066-1216*, 22-3, 66, 81, 88, 109, 128.



the Holy Trinity were founded in England and Wales, which ranked third in popularity for dedications after the Blessed Virgin Mary and St James. Of these ten monastic houses, the priory of Holy Trinity, Aldgate (known as Christchurch), in London was founded in 1107 or 1108 by Matilda, the wife of Henry I and Margaret's elder daughter, under the advice of Archbishop Anselm.<sup>20</sup>

In Scotland, Canterbury's influence on Dunfermline brought further dedications to the Holy Trinity. Urquhart Priory, which was Dunfermline's daughter house and was founded in 1136, was dedicated to the Holy Trinity.<sup>21</sup> King William I's charter (1172x1174) indicates that the cathedral church of Moray was also dedicated to the Holy Trinity. The Holy Trinity dedication moved with the location of the Episcopal see from Kinneddar (pre-1206) to Spynie (1206-1224) and to Elgin (1224 onwards).<sup>22</sup> In addition to these examples, Scone Abbey was the only new monastic house built on a pre-existing church site to be dedicated to the Holy Trinity, by Augustinian canons of St Oswald's Priory at Nostell whom Alexander I brought to Scone probably between 1114 and 1115.<sup>23</sup> Matthew Hammond has suggested, however, that if there was a pre-existing church at Scone, it might have been dedicated to St Michael, because a number of people in Perth from the late twelfth and early thirteenth centuries mentioned St Michael and at the feast day of St Michael the church was donated wax.<sup>24</sup> The dedication to the Holy Trinity at the parish church of St Andrews was also established in the early twelfth century, in the time of Bishop Robert (1124-59), when he was granted the revenues from it to the cathedral priory.<sup>25</sup> Given that one of the early churches

---

<sup>20</sup> *Ibid*, 26-7, 141.

<sup>21</sup> Cowan and Easson, *Medieval Religious Houses: Scotland*, 55; *The Charters of King David I*, no. 185.

<sup>22</sup> *RRS*, ii, no. 139; Hammond, 'Royal and Aristocratic Attitudes to Saints and the Virgin Mary in Twelfth and Thirteenth century Scotland', 69.

<sup>23</sup> Duncan, *The Kingship of the Scots, 842-1292*, 82-6.

<sup>24</sup> Hammond, 'Royal and Aristocratic Attitudes to Saints and the Virgin Mary in Twelfth and Thirteenth century Scotland', 71.

<sup>25</sup> *Liber Cartarum Prioratus Sancti Andree in Scotia*, ed. Thomas Thomas, Bannatyne Club (Edinburgh, 1841), 122-3; *RRS*, i, no. 239; Hammond, 'Royal and Aristocratic Attitudes to Saints and the Virgin Mary in Twelfth and Thirteenth century Scotland', 70.

founded on the Kilrymont at St Andrews, originally located between the church of St Rule and the east end of the cathedral begun by Bishop Arnold in 1160, was dedicated to St Michael,<sup>26</sup> as with Scone, the parish church of St Andrews dedication to the Holy Trinity might have had an association with the veneration of St Michael. Yet, in the case of Dunfermline Priory/Abbey and the cult of St Margaret, no earlier church/cult is known to have existed on the site before that founded by Margaret and, in consequence, was only associated with the priory and the cult of St Margaret.

Concerning the construction of the early church at Dunfermline, structural remains excavated during the archaeological investigation of the twelfth-century church at Dunfermline conducted by Peter Macgregor Chalmers in 1916 were interpreted as showing that in its final form before its replacement by David I's great Romanesque abbey church, the early church consisted of three approximately rectangular parts. Distinct structural changes between the second and the third portions were identified. As Richard Fawcett's analysis of the plan recovered by the 1916 excavation indicates, the first stage of the church consisted of a western compartment with walls about 7m long when measured from north-to-south, and measuring about 6.75m from east-to-west, and eastern compartment, which was a little smaller but longer, measuring over 13m in a total length. The main compartment of the second stage of the church consisted of a rectangle measuring about 8½ m from north-to-south and 11m from east-to-west, and at the east end of this compartment there was a semi-circular apse. In other words, on the plan, the first phase of the church consisted of a nave with a square tower, and the second phase a 'chancel' and an apse.<sup>27</sup>

In general an apse, which is a small and cramped space, was situated at the east end of a church as the backdrop to the high altar. In liturgical terms the eastern part of a church had

---

<sup>26</sup> *Ibid*, 71.

<sup>27</sup> The plan was published in RCAHMS, *Inventory of Fife* (Edinburgh, 1933), 107. For Richard Fawcett's analysis of the plan see Fawcett, 'Dunfermline Abbey Church', 27.

special significance. Facing eastward for worship, which had probably originally been the practice of both Jewish and pagan peoples, seems to have been established as a Christian tradition by the third century. It was based on ‘the symbolism of the rising sun, the symbol of the Messiah coming from the east, and the symbol of the risen Christ.’<sup>28</sup> Therefore, the main or high altar was placed at the east end of the church. It is also assumed that because the apse was the place for setting up the high altar, it was a suitable site for a major shrine in which the relics of the church, such as the Holy Rood at Dunfermline, were placed.<sup>29</sup> The second phase of the church seems to have consisted of a ‘chancel’, in which the monks gathered at certain times of the day to perform the liturgical routine of the Divine Office, and to its west a smaller nave of the first phase building, which was the whole part west of the rood screen. The walls of the nave were of massive thickness, which might have permitted a tower to be raised on them. Since it was not yet intended that the church at Dunfermline would become a major mausoleum or parish church, the primary purpose of one tower being erected on the walls of the nave may have been to house a bell. In contrast, the three towers of ‘David’s church’ in the mid-twelfth century would have been designed to show off its grandeur and, as discussed below, symbolize its dedication to Holy Trinity. The arrangement of such so-called tower-naves, as at Dunfermline, display strong similarities to Anglo-Saxon churches like those at Earl’s Barton (in Northamptonshire) and Barton-on-Humber (North Lincolnshire) which were comprised of tower-naves and chancels. There are other potentially similar Scottish churches. For example, Restenneth Priory in the thirteenth century had an older tower at the junction of its nave and choir, possibly in origin a porch or tower-nave of a late eleventh - or early twelfth-century date.<sup>30</sup>

---

<sup>28</sup> Connell, *Church Building and Furnishing*, 16.

<sup>29</sup> Fawcett, *Scottish Medieval Churches: Architecture and Furnishings*, 23-5; Nilson, *Cathedral Shrines of Medieval England*, 74-5; Tim Tatton-Brown, ‘Canterbury and the architecture of pilgrimage shrines in England’ in Morris and Roberts eds., *Pilgrimage*, 90.

<sup>30</sup> Fawcett, ‘Dunfermline Abbey Church’, 27-30; Fawcett, *Scottish Medieval Churches: Architecture and Furnishings* (Stroud, 2002), 69-77; Fawcett, *The Architecture of the Scottish Medieval Church 1100-1560* (New

Plan 1. The eleventh century church

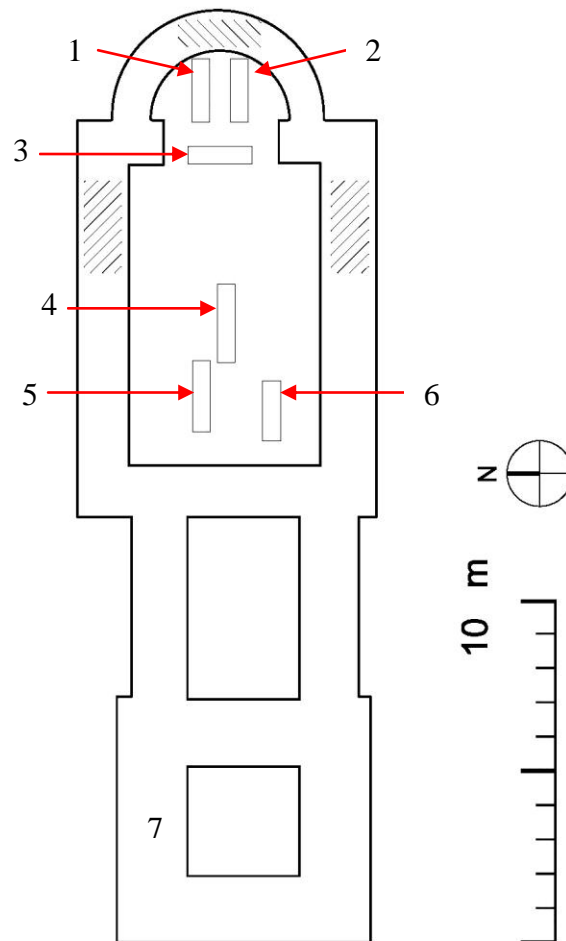

1. Malcolm III's tomb; 2. Queen Margaret's tomb (or 1. Malcolm III's tomb and 2. Prince Edward's tomb); 3. high altar (Holy Rood); 4. Queen Margaret's tomb (if the remains of Queen Margaret were translated, it was empty tomb); 5. Edgar's tomb; 6. Alexander I's tomb; 7. Tower

---

Haven and London, 2011), 7-9. For monks gathering to sing the official daily prayer of the church see McRoberts and Holmes, *Lost Interiors*, 66, 103.

As mentioned above, the eleventh-century church at Dunfermline appears to have had different stages in terms of construction. This has triggered scholarly debate about when and why the second stage of the building was carried out. For example, Eric Fernie has suggested that it was Margaret who commissioned both phases of the building. According to him, the church in which the marriage of Malcolm III and Margaret was held was probably made of wood and therefore, it is unlikely that any traces of that building would have survived. And the first building phase undertaken at the request of Queen Margaret was represented by the first masonry work. Fernie also provided evidence from the Norman building at Broughton in Lincolnshire, built in the late eleventh or early twelfth century, showing the same plan as that of the tower-nave of Dunfermline, to support his hypothesis that both building phases were probably conducted by Queen Margaret.<sup>31</sup> On the other hand, Stewart Cruden has argued that the first stage, in which Margaret's marriage took place, had been constructed prior to 1070.<sup>32</sup>

These arguments rely on the assumption that the marriage took place at the site on which the eleventh-century church was built. However, Turgot's *Life* just mentioned that 'she built an eternal memorial of her name and devotion in the place where her nuptials had been held.'<sup>33</sup> This passage does not contain information to let us know whether or not the wedding was held at the exact spot where the eleventh-century church stood. William Forbes-Leith, who translated Turgot's *Life* into modern English, also annotated that it was Dunfermline where 'the place where her nuptials had been held'. Chroniclers such as John of Fordun did not specify the place where the wedding took place. Instead, it was just mentioned that 'the

---

<sup>31</sup> Fernie, 'The Romanesque churches of Dunfermline Abbey', 26-7.

<sup>32</sup> Stewart Cruden called the first building 'King Malcolm's Church' and the second thing 'Queen Margaret's Church'. The thick nave walls to raise a tower above it were found at tower-nave buildings constructed before Norman invasion at Barton-upon-Humber, Lincolnshire and Earls Barton, Northamptonshire in England, and at Restenneth in Scotland, which makes it possible to insist that the so-called 'King Malcolm's Church' had been built before the marriage of Queen Margaret and the second part of this church was added by her (Cruden, *Scottish Medieval Churches*, 22-3; Eric Fernie, 'The Romanesque churches of Dunfermline Abbey' in Higgitt ed., *Medieval art and architecture in the diocese of St Andrews*, 26; Fawcett, 'Dunfermline Abbey Church', 27-30).

<sup>33</sup> Turgot, *The Life of St Margaret*, 29.

wedding was held....not far from the bay [Inverkeithing] where she brought up, at a place called Dunfermline.<sup>34</sup> In other words, it was not mentioned, and has not been conclusively proven that the wedding took place where the eleventh-century church stood. In addition, it is unknown whether or not there was a pre-existing church prior to 1070 on this site. However, it is known that there was ‘Malcolm’s Tower’ at Dunfermline, which was a king’s residence and likely had a royal chapel at the time. Therefore, as David MacGibbon and Thomas Ross, and Henderson have assumed, the wedding was probably held at the royal chapel of the Tower.<sup>35</sup> If this interpretation can be accepted, it seems likely that the eleventh-century church was built after 1070 as Turgot mentioned. That is, as far as the first phase of the eleventh-century building is concerned, it seems safe to follow Fernie’s presumption that it was constructed under Margaret’s patronage after 1070. In other words, if we can place any weight on how Turgot describes the sequence of events occurring at Dunfermline with the marriage taking place prior to the foundation and construction of the new church, then the marriage might well have been held at Malcolm’s Tower.

The building of the new church would have been followed by an introduction of monks from Canterbury. In response to Margaret’s request, Lanfranc, archbishop of Canterbury, sent Goldwin and two other monks to Dunfermline and told the queen that ‘you should endeavour resolutely and successfully to complete the work you have begun for God and for your souls.’<sup>36</sup> As we can see, it was not specified when the monks were dispatched. However, given Lanfranc’s appointment as an archbishop of Canterbury in 1070 and Lanfranc’s statement indicating ‘the work you have begun for God and for your souls’, it was definitely after the establishment of the new church at Dunfermline in 1070 when the monks were sent there from Canterbury.

---

<sup>34</sup> *John of Fordun’s Chronicle of the Scottish nation*, 202.

<sup>35</sup> David MacGibbon and Thomas Ross, *The Ecclesiastical Architecture of Scotland from the Earliest Christian Times to the Seventeenth Century* (Edinburgh, 1896), 230; Henderson, *The Annals Of Dunfermline And Vicinity*, 3-6, 12.

<sup>36</sup> Lawrie, *Charters*, no. IX, and p. 236, quoted in Barrow, *The Kingdom of the Scots*, 173; *ESSH*, ii, 31-2.

As Richard Fawcett suggests, the extension undertaken during the second stage of the church seems to have been intended to give enough space for the Benedictine monks who served Dunfermline Priory,<sup>37</sup> possibly following the instruction of Lanfranc's *Constitutions*. Fawcett argues that the second stage of the earlier church, which consisted of a larger choir with a semicircular apse, might have been constructed during the reign of Edgar (1097-1107). For this argument Fawcett suggests the possibility that in regard to the apse, the plan followed by MacGregor Chalmers' excavation at Dunfermline in 1916 was not accurate. Fawcett points out that MacGregor Chalmers' hope for the existence of the apse might have led him to interpret what he unearthed in that light, even though the evidence revealed in his archaeological investigation is wholly ambiguous.<sup>38</sup> Furthermore, Fawcett points out that while there were some Scottish churches with apsidal east ends such as a church at Hirsell prior to those identified at Dunfermline and Coldingham, it seems to have been the ecclesiastical revival in the late eleventh century and early twelfth century that saw the architectural style of the semi-circular apse brought to Scotland from England. This suggestion leads to his argument that the second stage of 'the eleventh-century church' was probably carried out later than the time of Queen Margaret, mostly probably in the reign of Edgar. He also argues that the arrival of new monks from Canterbury at Dunfermline between 1100 and 1107 may relate to the completion of the extension, and that the first burial place of Queen Margaret was in the first stage of building.<sup>39</sup>

There might, however, be a flaw in Fawcett's arguments. While he suspects the accuracy of MacGregor Chalmers' plan and the interpretation of the physical evidence for an apse to support his view that the second stage of building might be constructed in the reign of Edgar, Fawcett accepts that the apse existed in 'the eleventh-century church' at Dunfermline. In

---

<sup>37</sup> Fawcett, 'Dunfermline Abbey Church', 27-30.

<sup>38</sup> *Ibid*, 61, n. 3.

<sup>39</sup> *Ibid*, 31; Fawcett, *Scottish Medieval Churches*, 25.

other words, his argument to date the construction of the second phase of that church is based on the assumption that there was an apsidal east end to it. However, from his suggestion of the inaccuracy of the reading of the archaeological evidence by MacGregor Chalmers, a further question can be raised as to whether there was really an apse at all in ‘the eleventh-century building’ at Dunfermline church. If the plan with the apse arose from MacGregor Chalmers’ biased hope for the existence of such a design at Dunfermline, as Fawcett’s suggestion has it, then his own argument regarding the second stage of building is undermined. As Fawcett points out in respect of another of MacGregor Chalmers’ excavations, even although MacGregor Chalmers insisted that he found evidence of ‘a semi-circular apse’ at Jedburgh Abbey, re-excavation there in 1990 did not find any trace of one and there are good reasons to doubt if one ever had existed.<sup>40</sup> In the same context, unlike Fawcett’s assumption, it is possible that there was no apse in the earlier church at Dunfermline.

The twelfth century saw the foundation of Scottish churches having apsidal east ends such as Dalmeny church built probably in the 1130s and Leuchars church constructed in the second half of the twelfth century. Both churches had the same mason’s marks as those discovered at Dunfermline Abbey, which indicates that, as Richard Fawcett suggests, the same group of masons were involved in the building of these three churches and some of the masons would have previously worked for the construction of Durham Cathedral.<sup>41</sup> The analogies between a south doorway at Dalmeny church and a west doorway at Dunfermline could highlight the involvement of the same masons in these two buildings.<sup>42</sup> In addition, the

---

<sup>40</sup>Fawcett, ‘Dunfermline Abbey Church’, 61, n. 3; P MacGregor Chalmers, ‘A thirteenth century tomb in Glasgow Cathedral’, *Proceedings of the Royal Philosophical Society of Glasgow*, 1904-5 (Glasgow, 1905), vol. 36, 185; John Lewis and Gordon Ewart eds., *Jedburgh Abbey, the archaeology and architecture of a border abbey* (Society of Antiquaries of Scotland, 1995), 80-1.

<sup>41</sup> Fawcett, *The Architecture of the Scottish Medieval Church 1100-1560*, 53-5.

<sup>42</sup> See Figure 1 and 3.



dedication of Dalmeny church to St Cuthbert<sup>43</sup> suggests its association with Durham. The involvement of the same masons in the three buildings and the surviving apses at Dalmeny<sup>44</sup> and Leuchars could lead to speculation that Dunfermline did indeed have an apsidal east end in the early twelfth century. However, given that the masons from Durham are known to have built ‘David’s church’ rather than the ‘eleventh-century church’, and that it is presumed that they went to Dalmeny and Leuchars after this, the fact that the latter two have apsidal east ends should not be taken as firm evidence that there was a ‘semi-circular apse’ in the ‘eleventh-century church’ at Dunfermline.

Although Fawcett’s argument based on the date of erecting the apse in the earlier church at Dunfermline is perhaps incorrect, it is still likely that the second stage of the earlier building was added to provide monks with enough space for their liturgical activity. Thus, it can be posited that the extension of the second stage of the earlier church was begun in the time of Queen Margaret to give monks more space. In addition, given that her remains were buried in the second phase of building as discussed below, the construction of the second phase had already been launched before the demise of the queen, although the construction would not have been completed at this time.

Along with the aim to provide monks with enough space, there may have been other factors which led to the extension of the second part of the building. Given the association between Scottish kings and Durham, and the influence that Turgot (who was prior to the Benedictine community at Durham and Margaret’s one time confessor) exerted over the queen,<sup>45</sup> it can be considered that Durham’s leverage encouraged her to launch the extension

---

<sup>43</sup> Mackinlay, *Ancient Church Dedication in Scotland*, 225. Concerning the patron of Leuchars church, it is not sure who the patron is. Just St Bonoc can be suggested to be so, because the presence of a chapel of St Bonoc at the church is known (*Ibid*, 359, 482).

<sup>44</sup> See Figure 2.

<sup>45</sup> For the relationship between Scottish kings and Durham see Aird, *St Cuthbert and the Normans*, 227-68; Barrow, ‘The Kings of Scotland and Durham’, 311-24; Valerie Wall, ‘Malcolm III and the Foundation of Durham Cathedral’, 325-38; Paul Dalton, ‘Scottish Influence on Durham 1066-1214’ in Rollason, Harvey and Prestwich eds., *Anglo-Norman Durham, 1093-1193*, 339-52.



Figure 1. Dunfermline Abbey, the west doorway.



Figure 2. Dalmeny church, the south-east flank.



Figure 3. Dalmeny church, the south doorway.

of the church at Dunfermline. However, this possibility can be discredited. The chronicle of Simeon of Durham, written about 1105, has left some details of the building projects at the new church that was commenced at Durham in the 1090s, albeit not as detailed as the account of Gervase of Canterbury recording the new cathedral church built there. There seems to have been little significant construction until 1093 when a large scale building operation was launched at Durham in the context of an emerging trend to replace existing major Anglo-Saxon churches with huge new churches in the Romanesque style in post-Conquest England.<sup>46</sup> Therefore, the church of Durham under construction from 1093 was on an altogether more magnificent scale than the old-style Anglo-Saxon structure of the first phase of the church at Dunfermline. The evidence that Malcolm III, perhaps with Queen Margaret in attendance, was the only high-status layman who took part in the ceremonial laying of the foundation stone of Durham's new cathedral church in 1093<sup>47</sup> indicates that the king at least might have had an opportunity to grasp the future magnificence and scale of construction. However, since both Malcolm and Margaret died within months of the foundation ceremony at Durham, it is unlikely that the expansion of the church at Dunfermline was a response to the enormous church planned by Bishop William. Instead, the extension might have been prompted by the birth of Queen Margaret's children. The queen and Malcolm III seemed to have intended the church of Dunfermline to be the royal chapel. Therefore, the birth of her six sons and two daughters probably led her to prepare enough space for her offspring's burial places in the church. At this point, however, the building programme of Dunfermline was intended to make a royal chapel rather than a cult centre.

---

<sup>46</sup> *Symeonis Monachi Poera Omnia*, ed. T. Arnold, 2 vols., Rolls Series (London, 1882, 1885), vol. i. 10, 113, 128; M. G. Snape, 'Documentary Evidence for the Building of Durham Cathedral and its Monastic Buildings' in Coldstream and Draper eds., *Medieval Art and Architecture at Durham Cathedral*, 22-3; Klukas, 'The Architectural Implications of the *Decreta Lanfranci*', 163-5; Eric Cambridge, 'Early Romanesque Architecture in North-East England: A Style and its Patrons' in Rollason, Harvey and Prestwich eds., *Anglo-Norman Durham, 1093-1193*, 141-60; Malcolm Thurlby, 'The Roles of the Patron and the Master Mason in the First Design of the Romanesque Cathedral of Durham' in *Ibid*, 161-84.

<sup>47</sup> Barrow, 'The Kings of Scotland and Durham', 313.

Despite criticism of the imprecision of the 1916 investigation, it should be acknowledged that it did expose five burial sites, two of which had already been found in 1849.<sup>48</sup> MacGregor Chalmers' plan had two graves in the 'apse', the other three in the rectangular area to its west. If we accept his projected layout for the moment, the altar would have stood in the east end of the rectangular chancel area - as 'David's church had been build up, the rood screen would have filled the opening between the altar and the apse. Since the apse would have been used as a focus for the liturgy, if there was any space there it would be allotted for the clergy to sit in.<sup>49</sup> In this scenario there would not have been enough space to set up an altar in the apse itself, unless the two graves in the apse were wholly under the floor. It is unlikely that coffin shaped sarcophagi or effigies were used at the turn of the eleventh and twelfth centuries in Scotland. In fact, it was only with the Henry I's tomb at Reading (d.1135) that effigies began to be used on tombs in England, and even then it is not certain if Henry's effigy was installed at the time of his burial but later. The tufa carvings of Henry II and Richard I at Fontevrault in Maine, dated to c.1200 are the earliest surviving effigies of English kings.<sup>50</sup> It seems unlikely, therefore, that Scotland was in advance of England in adopting this fashion for funerary monuments, and it is probable that the type of monument over the two graves in the eastern apse at Dunfermline was the incised slab.

The tomb, it has been argued, was a 'representation of power' and not just a place where the dead were buried.<sup>51</sup> In particular, from the point of view of the medieval mentality, the location of a grave was important, because it was considered to represent political coalition, social status, family tradition, and connection in the relationship with the religious foundation where the dead were interred; being laid to rest in the sacred place was thought to

---

<sup>48</sup> Fawcett, 'Dunfermline Abbey Church', 31; see Plan 1.

<sup>49</sup> Fernie, 'The Romanesque churches of Dunfermline Abbey', 26-9.

<sup>50</sup> Duffy, *Royal Tombs of Medieval England*, 25.

<sup>51</sup> Mike Parker Pearson, *The Archaeology of Death and Burial* (Stroud, 1999), 198.

enhance the prospect of the dead individual's spiritual salvation.<sup>52</sup> Scholars have speculated on who was buried in the earlier church at Dunfermline. For example, Eric Fernie argued that of the three graves in the 'chancel', the grave in the middle is most likely to have been Queen Margaret's original burial site, because it corresponds to the textual evidence of the *Life*, which said that she was buried 'opposite (that is, in front of) the altar and the venerable sign of the holy cross' in the church at Dunfermline, and of Wyntoun (c.1350-c.1423) who mentioned that she was interred before 'the rood altar'. In addition, given that the founder was generally buried in front of the altar of the church he/she founded,<sup>53</sup> Fernie's suggestion for the first burial site of Queen Margaret is more reliable. On the other hand, Richard Fawcett suggests that the original burial site of Margaret was probably in the earliest section of the pre-David building. He highlights that a tale in the *Miracula* recalls how a miller was cured of his suffering after he drank water from a well, which was located beside the place in the church where the saint's remains had first been buried. The well is probably located in the sixth bay of the south aisle of the nave west of the transept. If the *Miracula*'s 'next to the tomb' meant a literal juxtaposition, the tomb might indeed have been situated in the western part of the earlier church. Fawcett has also argued that the rather biased investigation carried out in 1916 led to a wrong conclusion that there was no trace of burials in the western portion of the earlier church. Fawcett is of the view that a number of medieval tombs were placed within the earlier twelfth-century nave which was excavated in 1916, that is in the 'eleventh-century church', although many of those burials had been disturbed by later tombs as the excavation carried out in the south aisle of the nave in 1977 has indicated.<sup>54</sup>

---

<sup>52</sup> Jamroziak, 'How Rievaulx Abbey remembered its benefactors', 71-2; Jamroziak, 'Making friends beyond the grave', 327.

<sup>53</sup> Cruden, *Scottish Medieval Churches*, 35-6; Turgot, *The Life of St Margaret*, 81; *Chron. Wyntoun* (Laing), vol. ii, 165; Fernie, 'The Romanesque churches of Dunfermline Abbey', 29-30.

<sup>54</sup> Fawcett, 'Dunfermline Abbey Church', 31; T M Robertson, G H William, George Haggarty and Nicholas Reynolds, 'Recent excavations at Dunfermline Abbey, Fife', *PSAS*, 111 (1981), 395-9.

Some points of Fawcett's argument require reconsideration. Firstly, his suggestion based on the miracle story can be reviewed. The account of the miller's cure states that 'when he was brought to the place where her most holy body first lay buried, he tasted some of the water from the well next to the tomb.'<sup>55</sup> The statement indicating her most holy body 'first (*primo*)' lay buried means that there was at least one more burial site other than the original place. Therefore, from the story, it can be deduced that the miracle happened after 1180, when St Margaret's remains were translated for the first time, in consequence of which, another tomb was created. If so, it is not difficult to describe the tomb in the second stage of the 'eleventh century-church' as close to the well, compared to the distance of the 1180 tomb from the well. If this interpretation can be accepted, Fawcett's argument concerning the first burial site can be reassessed. Secondly, Fawcett's suspicion of the conclusion that there was no trace of burials in the first part of the 'eleventh-century building' can be also reconsidered. It is certain that there were a number of burials in the aisles of the nave, as the 1977 excavation carried out in the south aisle has indicated. However, the existence of a number of burials in the nave aisles could hardly be evidence to support the suggestion that there might be some medieval burials in the first stage of the 'eleventh-century church'. As David MacGibbon and Thomas Ross said in 1896, it had been known that the earlier church had been 'the place of royal sepulchre' including the interments of Queen Margaret and other royal personages.<sup>56</sup> In other words, the earlier church might have preserved the holy stations once rested in by St Margaret and the early kings, in consequence, the space might not have been disrupted by subsequent medieval burials. In addition, Turgot recorded that St Margaret was buried 'opposite (that is, in front of) the altar and the venerable sign of the holy cross' in the church at Dunfermline. If Margaret was interred in the first stage of the building, Turgot's statement concerning her burial place would have been worded differently.

---

<sup>55</sup> *Miracula*, 123.

<sup>56</sup> MacGibbon and Ross, *The Ecclesiastical Architecture of Scotland from the Earliest Christian Times to the Seventeenth Century*, 231.



It might be more probable on the basis of the above reasoning that the first tomb of St Margaret was the grave situated in the middle of the chancel of the second phase of the earlier church rather than in the western part of the earlier church. In addition, there is a possibility that four of the occupants of the five tombs found in the earlier church were Malcolm, Margaret, and their sons Edgar and Alexander I. In this case, a question can be raised: who was the occupant of the last tomb? The strong candidate would be Margaret. In other words, probably due to an early translation of the queen, an empty tomb was created. As Peter Yeoman cautiously suggests, it is possible that Margaret's remains were relocated while David I's building project was carried out,<sup>57</sup> and that this relocation resulted in the empty grave cut out found by Macgregor Chalmers. Another possibility, however, presents itself. When Malcolm's remains were brought from Tynemouth and buried at Dunfermline, Alexander I might have realigned his parents' tombs side by side, giving first rise of miracle tradition that her remains would not move without his, but behind the altar rather than in front of it in the chancel. Therefore, the occupants of two tombs in the possible apse might be King Malcolm and Queen Margaret. Furthermore, if this speculation is correct, it is worth noting that the tomb in the middle of the rectangular area, which is considered to be the tomb of the queen, became an empty tomb, but still a focus of possible veneration. Since the spot in front of the altar of the church was the most attractive site as a burial place, if Margaret's first tomb was empty, Alexander I might have intended to take it for himself or his queen, Sybilla. However, Alexander I was loyal to his parents, from which his motivation to translate his father's remains to Dunfermline and put his deceased parents close together probably derived. Alexander, therefore, might have been disinclined to take his mother's ex-burial site for his personal glory or benefit. Therefore, the tomb in the middle of the chancel might have

---

<sup>57</sup> Yeoman, 'Saint Margaret's Shrine at Dunfermline', 81.

remained empty after the translation of her remains to the apse, and Edgar and Alexander respectively were buried in the last two tombs.

However, it should be noted that these arguments concerning the occupants of the five graves are possible, only as long as the remains of Edward were not translated to Dunfermline. Stewart Cruden assumed that the occupants of the five tombs had been Queen Margaret, King Malcolm and three of their sons, Edward, Edgar and Alexander, and the argument is based on the account in the *Orygynale Cronykil of Scotland* written by Andrew of Wyntoun in the first decades of the fifteenth century, indicating that Edward was buried at Dunfermline.<sup>58</sup> If the remains of Edward were reburied at Dunfermline, he could have been interred beside his father in the apse. If so, Malcolm III and Edward were buried in the apse; Queen Margaret was laid to rest in the middle tomb in the ‘chancel’; Edgar and Alexander I were buried in the other two graves in the ‘chancel’. Yet, there is a clue to speculate that Edward was not buried at Dunfermline: St Margaret appearing in a vision stated that ‘the three following are my sons, kings who lie with me in this church.’<sup>59</sup> That is, St Margaret’s three sons, Edgar, Alexander I and David I were buried at Dunfermline. Thus, the miracle story leads to speculation that Edward was not an occupant of the five tombs.

Apart from architectural development and the increase of holy stations, relics might also have been one of the crucial factors required to boost a shrine and a cult. According to Turgot, ‘the church at St Andrews was much frequented by the devout.’<sup>60</sup> The popularity of St Rule’s church to pilgrims would have related to the relics the church possessed. The most valuable relic of the church was presumably originally contained within the so-called St Andrews’ sarcophagus, a tomb-shrine dated on art historical grounds to the late eighth and early ninth centuries; but, as Sally M. Foster assumes, it was apparently out of use and replaced by

---

<sup>58</sup> Cruden, *Scottish Medieval Churches*, 35-6; *Chron. Wyntoun* (Laing), vol. ii, 165.

<sup>59</sup> *Miracula*, 88-9.

<sup>60</sup> Turgot, *Life of St. Margaret, Queen of Scotland*, 59.

another receptacle prior to the twelfth century.<sup>61</sup> In addition, the church possessed the *Mòr Breac*, a reliquary of the Celtic Church, which might have been a jewelled box or another shrine such as the Monymusk reliquary, which contained the relics believed to be a tooth, a kneecap, three fingers of the right hand, and an arm bone of St Andrew the Apostle.<sup>62</sup>

As with the relics in St Rule's church which encouraged pilgrimage to St Andrews, St Margaret's relics likewise encouraged pilgrims to visit Dunfermline. Even if it is not certain which relics Dunfermline possessed in the later eleventh and earlier twelfth centuries, the inventories of Edward I after 1296<sup>63</sup> could provide a clue to speculate that Queen Margaret might have housed her portions of the 'Black Rude' and another 'box of silver-gilt and gems containing part of the Holy Cross and many small relics of the confessor St Edward' in her church. Given Queen Margaret's Anglo-Saxon royal lineage, it is not surprising that she possessed relics of St Edward. After the queen's death, her gospel books, shirts, and her other personal belongings including letters and charters might also have been placed in the church.<sup>64</sup> In addition, a 'head' shrine, which was probably made after St Margaret's head was separated at the 1250/1 translation, may have been displayed on the high altar on feast days.<sup>65</sup> It is also possible that some other relics collected by Scottish kings were housed at

---

<sup>61</sup> Sally M. Foster, 'Discovery, Recovery, Context and Display' in Sally M. Foster ed., *The St Andrews Sarcophagus: A Pictish Masterpiece and Its International Connections* (Dublin, 1998), 36-62, at 46.

<sup>62</sup> Yeoman, *Pilgrimage in Medieval Scotland*, 54. Some of St Andrews' relics could be thought to have been probably brought to the battlefield at Bannockburn in 1314, because Robert I granted St Andrews Priory annually 100 merks to commemorate the saint's aid to defeat the English forces at the Battle of Bannockburn when he was present at the consecration of the completed St Andrews Cathedral on 5 July 1318 (*Chron. Bower*, vi, 413; *RRS*, v, no. 500; Penman, 'Sacred food for the soul?').

<sup>63</sup> *CDS*, v, nos. 494 (1307), 799 (1344); F. Palgrave ed., *The Ancient Kalendars and Inventories of the Treasury of his Majesty's Exchequer*, 5 vols. (London, 1836), iii, 123-42, 166-95, 206-8, 262-70.

<sup>64</sup> Penman, 'Royal piety in thirteenth-century Scotland', 21, 24-5. For the later evidences of the usage of St Margaret's shirt see *Miracula*, xxxviii-xxxix and *ER*, v, 447, 512; *TA*, iv, 334. For St Margaret's gospel book, Turgot, *The Life of St. Margaret*, 66-8. Rebecca Rushforth insists that Queen Margaret possessed more than one gospel-book, given that her contemporary Judith of Flanders, wife of Earl Tostig, owned at least four. In addition, since there are some differences between Reginald of Durham's description of Queen Margaret's gospel book and Turgot's description, or the evidence of the extant book in the Bodleian, the book sent to Durham was probably another book of Queen Margaret (Rebecca Rushforth, *St Margaret's Gospel-book: The favourite book of an eleventh century Queen of Scots* (Oxford, 2007), 85-6).

<sup>65</sup> Yeoman, 'Saint Margaret's Shrine at Dunfermline Abbey', 88.

Dunfermline. Amongst them might have been the relics of St Cuthbert given to Alexander I (1107-24), when he took part in the translation of St Cuthbert at Durham in 1104.<sup>66</sup>

Overall, the veneration of Margaret herself presumably originated with her son Edgar, who obtained the crown after the political turmoil caused by the conflict for the throne between his half-brother Duncan II, elder brother Edmund and his uncle Donald Bán.<sup>67</sup> It is perhaps the case that to promote the cult of a future St Margaret and to show his support of the church at Dunfermline he brought new monks to Dunfermline from Canterbury between 1100 and 1107. Veneration was probably developed in earnest by Alexander I, who was attempting to re-invigorate the Scottish church and align it with the mainstream of Continental religious practices by introducing the Augustinian order into Scotland. As a result of his religious policy, Augustinian houses were founded at Scone and planned for Inchcolm, Loch Tay and St Andrews.<sup>68</sup> Given that Alexander I translated the remains of his father, Malcolm III from Tynemouth Priory to Dunfermline, and that he perhaps moved the body of his mother, Queen Margaret and laid it beside Malcolm III's, Alexander I probably completed the second phase of the early church in the course of translating the remains of his father and perhaps his mother. In this phase of the earlier church, the kings, Edgar and Alexander I played a leading role in promoting the veneration of Margaret.

---

<sup>66</sup> Barrow, 'The Kings of Scotland and Durham', 316.

<sup>67</sup> Oram, *David I*, 44-5. Edmund was buried at Montacute in England (*John of Fordun's Chronicle of the Scottish nation*, 213).

<sup>68</sup> For Alexander I's religious policy to re-establish the Scottish church see Barrow, *The Kingdom of the Scots*, 154-6; Duncan, *Scotland*, 131-2; M. Lynch, *Scotland: A New History* (London, 1992), 79; Kenneth Veitch, 'Replanting Paradise': Alexander I and the reform of religious life in Scotland', *Innes Review* vol. 52, no. 2 (Autumn 2001), 136-66.

### **(3) The Twelfth century church**

Through the eleventh and twelfth centuries the cult of saints in Europe developed with an increase of popular belief in saints' intercessory power. This development encouraged more of the laity to undertake pilgrimages to saints' shrines. The increased flow of pilgrims caused congestion at many older shrines, which necessitated the extension of the churches in which they were housed to provide suitable space both for the pilgrims who wanted to get as close as possible to shrines and also for the monks or other clergy who wished to observe their liturgical activities without interruption.<sup>69</sup> Allied to this, it is likely that an increase in the number of clergy was also a reason for the enlargement of a church.<sup>70</sup> At Dunfermline, as a result of David's efforts, the priory was raised to abbatial status in 1128.<sup>71</sup> Only four years earlier, 13 monks were sent from Canterbury at David's request<sup>72</sup> and the construction of the new church commenced. These would have firmed up Lanfranc's *Constitutions* in use. David launched a building project at Dunfermline shortly after his inauguration in 1124 with the issue of an act for the church at Dunfermline between 1124 and 1128, commanding 'Constantine and all men belonging to the church of the Holy Trinity' to help the work begun there, and indicating that if they refuse to do so, the king's grieve Swain would help the prior to compel them.<sup>73</sup>

Moreover, David I might have linked his effort to secure the rite of coronation and unction for Scottish kings with the elevation of Dunfermline to abbatial status<sup>74</sup> and to

---

<sup>69</sup> Oram, 'The Medieval Bishops of Whithorn, their Cathedral and their Tombs', 148-9. Although Oram is talking it in the context of probably thirteenth century development at Whithorn, his statement can also be in part adopted to the early twelfth century context at Dunfermline.

<sup>70</sup> Eric Fernie suggested that St Anselm's crypt was probably built to accommodate increasing the number of monks (Fernie, 'St Anselm's Crypt' in Peter Draper and Nicola Coldstream eds., *Medieval Art and Architecture at Canterbury before 1220* (Leeds, 1982), 27.

<sup>71</sup> *The Charters of King David I*, 63-4. Canonically to get qualification for abbatial status the number of monks belonged to the church must be over twelve (accessed on <http://www.newadvent.org/cathen/>).

<sup>72</sup> *Chron. Bower*, iii, 147; Cowan and Eason, *Medieval Religious Houses: Scotland*, 58; Henderson, *The Annals Of Dunfermline And Vicinity*, 41.

<sup>73</sup> *Registrum de Dunfermelyn*, no. 18.

<sup>74</sup> Duncan, *The Kingship of the Scots 842-1292*, 115; Dauvit Brown, *Scottish Independence and the Idea of Britain from the Picts to Alexander III* (Edinburgh, 2007), 15-8.

disassociate this rite from his brother's foundation at Scone. The layout and structure of the abbey church at Dunfermline seems to have been designed to accommodate the coronation ritual. For example, until the 1180 translation of the earlier burials from the original church to the new abbey church, there were two tombs - those of David and Malcolm IV - in front of the high altar in the extended church at Dunfermline. The kings' bodies would have been laid under the floor covered by flat grave-slabs, which might have been necessary for securing enough unimpeded space for the rite of coronation to take place in the vicinity of the altar. David would have been motivated to attempt to receive the rite of unction and coronation by his experiences of the elaborate English king-making rituals that had been adopted by the Norman kings and by his understanding of the enhanced prestige which a full coronation lent to Norman kingship. His high-status presence at Henry I's court and his awareness of the function of Westminster Abbey alongside the royal palace there, as a place in which the religious ceremony of coronation took place and the secular festivities around it were enacted, perhaps stimulated a desire to emulate English practice and to provide an equivalent ritual setting. There may too have been some influence from his sister Queen Matilda of England (d.1118), who had been crowned and eventually buried in Westminster.<sup>75</sup>

According to the twelfth-century chronicle of Holyrood, David's church at Dunfermline was consecrated in 1150.<sup>76</sup> Its consecration presumably took place on Trinity Sunday, 11 June 1150.<sup>77</sup> At the time of the consecration, construction of the nave is unlikely to have been completed. This is suggested by the stylistic difference between the arcade levels: the upper part showing simpler decoration than the lower level. Since David was not likely to have reduced the cost of construction for his burial place, the upper storey must have

---

<sup>75</sup> Barbara Harvey, *Westminster Abbey and its Estates in the Middle Ages* (Oxford, 1977), 20-5; Oram, *David I*, 145, 159.

<sup>76</sup> *A Scottish chronicle known as the Chronicle of Holyrood*, ed. Anderson, 35.

<sup>77</sup> *The Charters of King David I*, 136. Easter day in 1150 was on 16 April, in 1084 (the believed year of David I's birth) on 31 March and in 1124 (the year of his inauguration) on 6 April (Cheney, *Handbook of Dates*, 134-5, 102, 114).

been completed after the dedication in 1150 and David's death in 1153.<sup>78</sup> It was not uncommon that a church dedication was carried out before the completion of construction, provided the portion of the building within which the main liturgical activity would be undertaken could be provided with temporary wooden roof. For example, on 4 October 1077 when Canterbury Cathedral was consecrated, only the choir, transept and two or three bays of the nave were probably completed. When Glasgow Cathedral was consecrated in 1197, the church was still under construction and, indeed, probably never attained completion before a completely new building was commenced in the thirteenth century.<sup>79</sup> The new church at Dunfermline consisted of a nave, which was as wide between the pillars as the old aisle-less church which had formerly occupied that position, with a crossing and choir standing eastwards of Margaret's church. In the new church, the high altar of the old building presumably became the rood altar,<sup>80</sup> and that the line of the new building's rood screen was positioned to the east beyond the altar.

After the Reformation of 1560 and before the 1690s from when the earliest pictorial representations of the abbey date, some parts of the church at Dunfermline were ruined. The east end, crossing and north and south transepts were destroyed, and only seven bays of the nave's original eight survive. There are two doorways in the extant south wall of the nave, the eastern of which was in the second bay from the south transept and was used as the monks' processional entrance to and from their cloister. It retains its original twelfth-century form but its western counterpart was rebuilt in the fifteenth century. The grand processional entrance of the church was the great west doorway, which was used on special occasions.<sup>81</sup> Although processions were the most crucial part of ritual, no extant evidence of the procession practice

---

<sup>78</sup> Fawcett, 'Dunfermline Abbey Church', 44.

<sup>79</sup> Francis Woodman, *The Architectural History of Canterbury Cathedral* (London and Boston, 1981), 28; A.A.M. Duncan, 'St Kentigern at Glasgow Cathedral in the Twelfth Century' in Richard Fawcett ed., *Medieval Art and Architecture in the Diocese of Glasgow* (Leeds, 1998); Fawcett, *Scottish Medieval Churches*, 21.

<sup>80</sup> Eeles, 'The development and internal arrangement of the abbey church of Dunfermline', xxxi-xxxii.

<sup>81</sup> Fawcett, 'Dunfermline Abbey Church', 33; Fawcett, *Dunfermline Abbey & Palace* (Edinburgh, 2004), 11-27.

at Dunfermline has remained. The practice of other Benedictine foundations, however, can allow us to speculate how processions were performed at Dunfermline. On special occasions, such as Palm Sunday, the route of procession carried out by the monks of Canterbury who observed Lanfranc's *Constitutions* included a certain place outside the precinct of a religious community. The *Constitutions* set out that:

The order of the procession, which was a dramatic representation of Our Lord's entry into Jerusalem, and which the text tends to confuse, was as follows. (1) The whole community walks in procession, with chant, to a chosen spot outside the walls of the city, where a halt is made. (2) Two priests then take up a portable shrine, containing the Blessed Sacrament, previously brought thither, the others surround the shrine-the children representing the Hebrew children, and the monks the crowd. (3) All then move in procession back to the gate of the city (representing the gates of Jerusalem), where a second halt is made and the hymn *Gloria, laus* is sung by the children and monks. (4) All then move to the west main door of the church, where a third halt is made, and anthems are chanted recalling the conduct of Caiaphas and the Pharisees. (5) All then enter the church, and a fourth halt is made before the crucifix at the entry to the choir.<sup>82</sup>

*The Rites of Durham*, which compiled old rites and customs of Durham and was written in 1593, describes how processions were conducted by the monks of Durham in the Middle Ages. In the procession on crucial days such as Ascension, Whitsunday and Trinity Sunday the monks of Durham proceeded out of the church after service and circulated around the precinct: the monks went out to the church yard through the north door of the church; up to 'Layegaite' by the 'Bowe church' which was St Mary's church in the north bailey; down to the 'abbey gate' at the south bailey where a number of people stood; crossed the church yard at the south part of the precinct; through the cloister and returned to the church. Men waiting for the procession at the abbey gate followed the procession. However, women were not

---

<sup>82</sup> *The Monastic Constitutions of Lanfranc*, 36-7 (n. 131). See also David Chadd, 'The Ritual of Palm Sunday: Reading Nidaros' in Margaret Syrstad Andas, Oystein Ekroll and Andreas Haug eds., *The Medieval Cathedral of Trondheim: Architectural and Ritual Constructions in their European Context* (Turnhout, 2007), 253-78; Allan Doig, *Liturgy and Architecture From the Early Church to the Middle Ages* (Aldershot, 2008), 186-7.



allowed to come through the gate.<sup>83</sup> Such activity suggests conscious prohibition excluding women from the cloister, and would have reflected the growing tradition of St Cuthbert's misogyny, which developed in the years after 1083.<sup>84</sup> Furthermore, although the monks of Durham did not process outside the walls of the city, as the monks of Canterbury did in their procession on Palm Sunday, the whole community of Durham on Corpus Christ day - a principal feast at that time - walked to a specific spot called 'Wyndshole yett' at the north-west corner of the north bailey. There the monks in the procession met the portable shrine, called the Corpus Christ shrine, which was carried from St Nicholas Church at the town market place. The shrine was carried into Durham Cathedral Church, with the community and people of the town following it.<sup>85</sup>

It is not surprising that these examples of the performance of processions at Canterbury and Durham show differences to some extent, because Benedictine communities with their own unique cults/relics, as mentioned above, could exercise a certain degree of autonomy in terms of liturgical practices. The monks at Dunfermline probably would have performed their processions in a similar way to those of other Benedictine churches. The processing monks at Dunfermline entered the church through the eastern doorway in the south nave wall. Before the monks at the rear of the procession came into the choir, the procession halted in front of the rood altar. In the procession, the holy water-bearer would have proceeded in front, being followed by the cross-bearer carrying the processional cross and the thurifer between two candle or torch carriers.<sup>86</sup> Along with them, as *The Rites of Durham* mentioned, holy relics the abbey possessed would also have been carried by the monks. On special occasions such as Trinity Sunday and Whitsunday, the monks of Durham in the procession carried holy relics such as St Bede's shrine, the image of St Oswald and St Aidan, and - only after 1346 -

---

<sup>83</sup> *Rites of Durham*, 105-6, 287-8 and Three Plans of Durham Cathedral Church and its surrounding area.

<sup>84</sup> For St Cuthbert's misogyny see Chapter One.

<sup>85</sup> *Rites of Durham*, 107-8, 288 and Three Plans of Durham Cathedral Church and its surrounding area.

<sup>86</sup> Aymer Vallance, *Greater English Church Screens: Being Great Roods, Screenwork and Rood-Lofts in Cathedral, Monastic and Collegiate Churches in England and Wales* (London, 1947), 15-6.

St Margaret's cross etc.<sup>87</sup> The monks at Dunfermline on special feasts (before 1296) might also have carried holy relics like Queen Margaret's portions of the 'Black Rude', relics of St Cuthbert, Queen Margaret's gospel books, shirts, head shrine etc. The rest of the practices in the procession would have been similar to the way they were performed at other churches, as mentioned above. However, some variation to the procession at Dunfermline would have been occasioned by the presence or otherwise of a town wall and a precinct wall around the abbey.

Although in 1303-4 when Edward I stayed at Dunfermline, he ordered a ditch dug around the town<sup>88</sup> for defensive purposes, there is no evidence for a permanent defensive wall being built around the burgh, in common with most other Scottish medieval towns. It was, however, provided with gates to regulate traffic entering it. Archaeological investigations have found the remains of the abbey precinct wall,<sup>89</sup> although it is still unknown when exactly it was built. Until the town wall was built, unlike other churches such as Canterbury Cathedral, the procession on Palm Sunday at Dunfermline might have set out for a chosen spot in the precinct - if the precinct wall was built - such as the gate of the precinct wall, or other churches/chapels around the burgh such as St Ninian's Chapel and St Mary's Chapel or one of the hospices.<sup>90</sup> In addition, another possibility is that although there was no town wall, the burgh had gates that defined its physical limits. Thus, the procession could have started outside one of the gates. The procession then re-entered the church through the great west doorway, outside which poor pilgrims probably begged for alms, as is recorded in one of the St Margaret miracle stories.<sup>91</sup> The station stopped at by the monks in the procession before

---

<sup>87</sup> *Rites of Durham*, 105-6.

<sup>88</sup> *Documents illustrative of the History of Scotland*, ed. J. Stevenson, ii, 30; *Chron. Bower*, vi, 296-7, 421; *CDS*, iv, 136.

<sup>89</sup> David Perry, 'Dunfermline: from 'Saracen' castle to 'populous manufacturing royal burrow', *PSAS*, 129 (1999), 789-93.

<sup>90</sup> Dennison, 'Living in Medieval Dunfermline', 5.

<sup>91</sup> *Miracula*, 78.

entering the choir would have been the rood altar at the east end of the nave. Then the monks entered the choir through the rood screen and a pulpitum.

In common with the case of other Scottish religious houses, most books of Dunfermline have not survived with the exception of a few examples: one of which was the so called *Psalter of Abbot Richard Bothwell* of Dunfermline (1444-68) showing the date of a psalter.<sup>92</sup> In spite of the survival of this book, it cannot be said how the monks of Dunfermline performed the liturgy. Instead, it is possible to suggest that the liturgical practice at Dunfermline was strongly influenced by Canterbury, given the relationship between Dunfermline and Canterbury at the end of the eleventh century and the first half of the twelfth century: including the connection between Queen Margaret and Lanfranc; the dispatch of monks from Canterbury to Dunfermline at the request of King Edgar; the arrival of 13 monks at Dunfermline from Canterbury in 1124 at David I's request; and the appointment of Geoffrey, prior of Christ Church at Canterbury, as the first abbot of Dunfermline by David I in 1128. However, this does not mean that the liturgy of Canterbury was transplanted into Dunfermline easily. Just as pre-existing Culdees at St Andrews remained as a group of regular canons even after the foundation of the Augustinian priory there in 1144,<sup>93</sup> so it is assumed that the new religious order should compromise with the pre-existing church. In other words, the liturgy at Dunfermline would have been formed by the influence of Canterbury's liturgy, adding to the pre-existing liturgical practices performed by the Scottish church.<sup>94</sup>

---

<sup>92</sup> John Higgitt, 'Dunfermline Abbey and its Books' in Fawcett ed., *Royal Dunfermline*, 177-86.

<sup>93</sup> Barrow, *The Kingdom of the Scots*, 187-202.

<sup>94</sup> Turgot's *Life* demonstrates the existing practices of Scottish Church when Margaret tried to reform the Scottish Church. For instance, in the Scottish Church, Lent began on the first Monday after Ash Wednesday and fasted for six weeks before Easter. Since Sunday was not counted, six weeks was only thirty six days. In contrast, in the Catholic Church the fast of Lent commences on the fourth day of the week from the beginning of the Lent, the duration of the fast was forty days. The Scots did not receive the Holy Eucharist on Easter, and did not make regular confession of their sins. The Scots might have ignored the worship on Sunday because of their worldly business. The Scottish Church did not prohibit the marriage of a man with his step-mother, and a brother with a widow of his brother. In addition, in some regions of Scotland there were strange customs in the

Turning to the discussion to the screens, medieval churches had several screens. Of these, a pulpitum or a choir screen and a rood screen were the most important. The first was positioned at the west end of the choir, and usually had a large central door. Since the choir screen closed off the view of the choir from the ambulatory and the nave, the monks serving daily services could do so with fewer interruptions. The pulpitum at Dunfermline was probably placed within the western arch of the crossing, with a central door. In front of the door, pilgrims would have kept vigils and prayers.<sup>95</sup> Since there is no extant example of a twelfth-century Scottish choir screen, a later screen could provide a clue to conjecture that of Dunfermline. The mid-fifteenth-century choir screen of Glasgow Cathedral had four panels on each side of a central door, and on the eight panels sculptures of the cathedral's saints or royal patrons were carved. In the late fifteenth century, the sculptures were replaced by two platforms, on which two altars were set up in dedication to the Holy Name and Our Lady of Pity.<sup>96</sup>

A rood screen stood to the west of the choir screen. Its name was derived from the painted image of the rood, i.e. of Christ on the Cross, often flanked by painted images of the Virgin Mary and St John the apostle to either side, which was placed on a horizontal beam above the screen. It often had two doors, which allowed access and egress to the eastern end of the church. Between the two doors, on the western surface of the screen, there was the nave altar or rood altar for the laity. In general, such nave altars were dedicated to the Holy Cross or Holy Rood as at Canterbury, or to Jesus as at Durham.<sup>97</sup> At Dunfermline, one bay further west of the pulpitum, there is the surviving lower portion of a rood screen, with

---

Mass served with 'barbarous rite', although Turgot did not describe these rites in detail (Turgot, *The Life of St Margaret*, 45-52; Barrow, *Kingship and Unity*, 71-3).

<sup>95</sup> *Miracula*, 83.

<sup>96</sup> McRoberts and Holmes, *Lost Interiors*, 105-6.

<sup>97</sup> Fawcett, *Scottish Medieval Churches*, 288-90; Thomas E. Russo, 'The Romanesque Rood Screen of Durham Cathedral: Context and Form' in Rollason, Harvey and Prestwich eds., *Anglo-Norman Durham, 1093-1193*, 257-8. For the dedication of the nave altar at Canterbury see R. Willis, *The Architectural History of Canterbury Cathedral* (London, 1845), 37. For the dedication of the nave altar at Durham see *Rite of Durham*, 32.

vestiges of doorways flanking the site of the nave altar.<sup>98</sup> The nave altar - the high altar until 1150 - at Dunfermline seems to have been dedicated to the Holy Rood, probably through association with the relics of the True Cross once possessed by St Margaret,<sup>99</sup> or the Trinity until 'David's church' was consecrated in 1150; thus the high altar was moved to the new choir. From the paintings of the Last Judgement seen from the choir side and the crucifixion from the nave side drawn on the Elgin rood screen which was still visible in 1640,<sup>100</sup> it can be speculated that some of the most important events of the Bible were probably depicted on the rood screen at Dunfermline. Dunfermline church east of the rood screen was the conventual church, while the rest served as the parish church. That is, as other churches did, the rood screen at Dunfermline separated the monks in the choir from the laity in the nave, enabling the monks to perform their services without interruption from the laity, while the nave altar could be used as a spiritual focus for the laity even during the performance of services in the choir. In addition, the rood screen doors at Dunfermline Abbey gave access to an aisle ambulatory to the east and west sides of the monks' choir, permitting a flow of pilgrims around the central compartment.

In some churches such as Durham Cathedral, the rood screen was placed to the west of the door which connected the south aisle or south transept to the cloister. Thus the screen could function as a bar to control the entrance-way to the east end of the church, and to prohibit lay access to the cloister.<sup>101</sup> Unlike at Durham Cathedral, in the twelfth-century church at Dunfermline the screen was unusually placed to the east of the south-east door - close to St Margaret's altar - in the nave, which connected to the cloister. This positioning means that the rood screen at Dunfermline did not function as a barrier which prevented the intrusion of the laity into the cloister. Instead, pilgrims or residential guests could potentially

---

<sup>98</sup> Fawcett, 'Dunfermline Abbey church', 34-5.

<sup>99</sup> Eeles, 'The development and internal arrangement of the abbey church of Dunfermline, xxxii.

<sup>100</sup> McRoberts and Holmes, *Lost Interiors*, 107.

<sup>101</sup> Russo, 'The Romanesque Rood Screen of Durham Cathedral', 258-9.

have left the church through the door. However, as Lanfranc's *Constitutions* instructed, guests were not to be allowed to wander around the cloister without guidance of the guestmaster,<sup>102</sup> and pilgrims in some way would have been prohibited from entering unsupervised into the cloister of Dunfermline Abbey. This also meant that the monk's procession had to link up with the laity in the nave/parochial church.

For pilgrims, there were four identifiable cult foci in the church at Dunfermline. Chapter 13 of the *Miracula* tells us that a sufferer was brought 'before the altar of St Margaret' in the south aisle of the nave; while she was sleeping, the saint said to her, 'go to the place where my bones rested'; she went there and slept on 'the stone of the queen's tomb' in the nave, which was supposed to be empty. The female pilgrim was cured and her parents brought her to 'St Margaret's shrine' in the choir next to the high altar, to where the remains of the saint had been translated in 1180.<sup>103</sup> If the miracle occurred after the 1250/1 translation, St Margaret's shrine as mentioned in Chapter 13 would mean the shrine in the feretory chapel at the east end of the church. This miracle story confirms that an empty tomb was also a locus of supernatural power. In general, an empty tomb symbolized Jesus' resurrection,<sup>104</sup> and it was not uncommon that an empty tomb should play a significant role as a cult focus.<sup>105</sup> In the *Miracula*, St Margaret's well which was located in the present-day third - but medieval fourth, if one bay out of the nave's original eight has been lost - bay from the west end of the nave's south aisle was mentioned eight times. Pilgrims made devotional visits to this well to seek cures using its water. For example, a blind woman restored her sight after she drank water

---

<sup>102</sup> *The Monastic Constitutions of Lanfranc*, 129-31. For the use of space in Medieval monasteries see Roberta Gilchrist, 'Community and Self: Perceptions and Use of Space in Medieval Monasteries', *Scottish Archaeological Review*, vol. 6 (1989), 55-64.

<sup>103</sup> *Miracula*, xliv, ch. 13. At Glasgow Cathedral and Whithorn Priory, the empty tomb had also been attracted as a cult site by the pilgrims (Yeoman, *Pilgrimage in Medieval Scotland*, 23, 39).

<sup>104</sup> For the symbolism of the empty tomb as a Christian motif see D. Smith, *Revisiting the Empty Tomb: The Early History of Easter* (Minneapolis, 2010).

<sup>105</sup> An example of this case is St Swithun in Winchester, which has been researched widely (Martin Biddle, 'Archaeology, architecture and the cult of the saints in Anglo-Saxon England', *The Anglo-Saxon Church: Papers on History, Architecture and Archaeology in Honour of Dr H. M. Taylor*, eds. L. A. S. Butler and R. K. Morris (London, 1986), 18-25).

from the 'fountain' of St Margaret and washed her eyes; and a woman possessed by a demon was cured after she met St Margaret in a dream-vision while she was sleeping there.<sup>106</sup> In other words, other altars and tombs aside, pilgrims visited the altar of St Margaret in the nave, St Margaret's well in the nave and the empty tomb at the site of the earlier church in the nave as well as the new shrine of 1180 in the choir to seek her saintly intercession.

Concerning cult foci, architectural evidence seems to indicate that the 'supposed' St Margaret's original burial site in front of the nave altar was surely the most significant place in the church prior to 1180. Unlike other pillars in the nave, the second and the third pillars from the east-end of the nave, the area where St Margaret's remains were laid until their 1180 translation, were enriched with the incised spiralling pattern which is found in other churches such as Waltham and Selby, or chevron pattern which can be seen at Durham. As with Richard Fawcett's suggestion regarding the incised spiralling pattern of pillars next to the nave altar at Norwich Cathedral, the pillars standing on the same - or similar - line of the nave altar might have been designed to highlight the altar.<sup>107</sup> However, the enrichment of the second and the third pillars from the east-end of the nave at Dunfermline<sup>108</sup> might have been intended to make the area where St Margaret's body was originally buried distinct from other places rather than to emphasise the nave altar. The decoration of the first three pillars perhaps also related to the symbolic significance of the veneration of the Holy Trinity. Moreover, the holes around the responds of the second pillars<sup>109</sup> might have been used to suspend the clothing relics in order to emphasise the holiness of the nave altar. On the base of the second pillars, there are slots which might have been intended for use setting up the portable wooden screens between the second and the third pillars. Along with the rood screen standing just

---

<sup>106</sup> *Miracula*, chs. 3, 18, 25, 27, 29, 30, 39, 41. The fountain had been placed outside the eleventh church, but it was incorporated within the twelfth century church. This kind of well is also found at the cathedrals of St Andrews and Glasgow (Malcolm Thurlby, 'St Andrews Cathedral-Priory and the Beginning of Gothic Architecture in Northern Britain' in Higgitt ed., *Medieval art and architecture in the diocese of St Andrews*, 49).

<sup>107</sup> Fawcett, *The Architecture of the Scottish Medieval Church 1100-1560*, 23-4.

<sup>108</sup> See Figure 4.

<sup>109</sup> See Figure 5.

behind the nave altar as viewed from the nave, the screens might have controlled not just the flow of pilgrims who came to visit to St Margaret's tomb but affected the flow back west to the St Margaret's altar and well. The emphasis of this area might be related to the relative axis of the nave in relation to the graves' site indentified in Chalmers' dig and laid out on the present-day floor: more space has been deliberately left on the north of the nave to admit pilgrims/ laity to the parish church.<sup>110</sup>



Figure 4. Dunfermline Abbey, the second and the third pillars from the east-end of the nave.

---

<sup>110</sup> See Figure 7.





Figure 5. Dunfermline Abbey, the holes around the responds of the second pillars.



Figure 6. Dunfermline Abbey, the slots on the base of the second pillars.



Figure 7. Dunfermline Abbey, the nave looking east.

Until the 1180 translation of St Margaret's remains, cult foci were situated in the parish church. To visit these devotional foci, the laity/pilgrims entered the church through the parish doorway, which was in the second bay from the west in the north aisle of the nave connecting to the burgh, and they could access or see St Margaret tomb and probably the associated empty tombs in the nave with relative ease. Analysis of the location of these devotional sites enables some more detailed discussion of access arrangements and the internal route of the laity in the twelfth-century church. On the assumption that St Margaret was buried in the middle tomb of the rectangular compartment of the earlier church until her 1180 translation, and Malcolm III and Prince Edward were buried in the 'apse', it might be conjectured that pilgrims until 1180 entered the church through the parish doorway, walked up the nave to the site of the second stage building of the earlier church, where Queen Margaret's grave was

situated. They would have halted to pray before the tomb and the nave altar, and then headed for St Margaret's altar where her personal possessions might alternatively have been kept and the saint's well in the nave along the south-west aisle of the nave. The laity who wanted to visit some spots in the conventual church, walked to the east side along the south aisle of the nave up to the southern doorway in the rood screen. Passing through the door they would have turned to the north and halted before the tomb of Malcolm III (who also came to be considered as a saint),<sup>111</sup> this was in the area between the rood screen and the choir screen at the time and was where the apse of the 'eleventh-century church' had been located. From there they walked up the north aisle along the north side of the monks' choir to the end of the eastern limb of David I's church where they would have halted to the north of the tomb of David, which was located in front of the high altar - some of the relics like Margaret's gospel book, True Cross, her 'sark' and her other personal belongings might have displayed on the high altar on special occasions. Having completed their devotions there, they then came back along the south aisle; passed through the southern doorway in the rood screen; and then finally exited (as they had entered) via the north-west doorway of the nave.

A more complicated sequence would have arisen if, as discussed above, there had been one more empty tomb of Queen Margaret: that is, if St Margaret had been reburied along with her husband in the apse in the earlier church and lay there until 1180. That tomb would have been located before the rood screen and behind the nave altar as viewed from the nave. In this case, the end part of the nave would have contained two tombs of St Margaret and the tomb of Malcolm III, which would increase the significance of this area in devotional terms. Additionally, the physical location of the rood screen would have been relocated. Since the high altar of the old building had probably stood on the line of the rood screen in David's

---

<sup>111</sup> *Chron. Bower*, iii. 71.

Plan 2. The twelfth century church (before 1180)

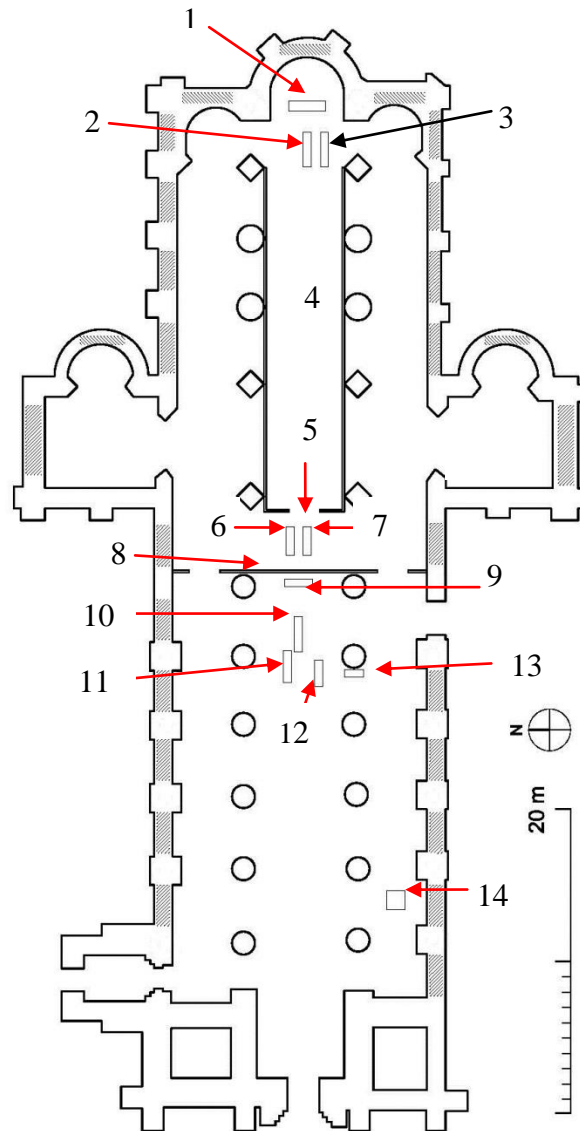

1. high altar (Trinity/Virgin); 2. David I's tomb; 3. Malcolm IV's tomb; 4. choir; 5. pulpitium;  
6. Malcolm III's tomb; 7. Prince Edward's tomb; 8. rood screen; 9. rood altar; 10. St  
Margaret tomb; 11. Edgar's tomb; 12. Alexander I's tomb; 13. St Margaret's altar; 14. St  
Margaret's well

Plan 2(2). The twelfth century church (before 1180)

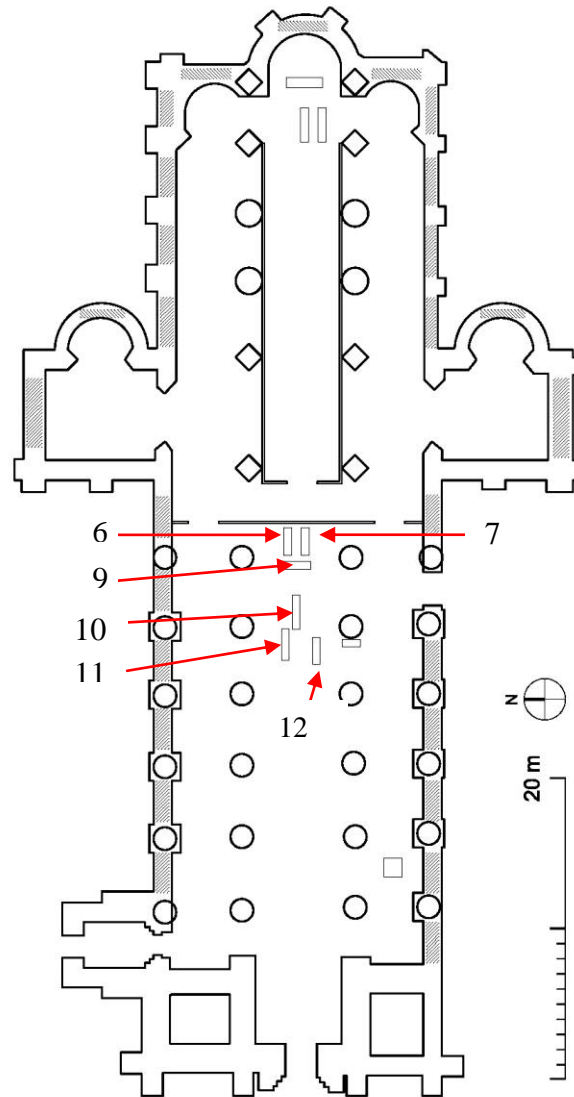

6. Malcolm III's tomb; 7. St Margaret's tomb; 9. rood altar; 10. St Margaret's original tomb (empty tomb); 11. Edgar's tomb; 12. Alexander I's tomb

Plan 2(3). The twelfth century church (after 1180)

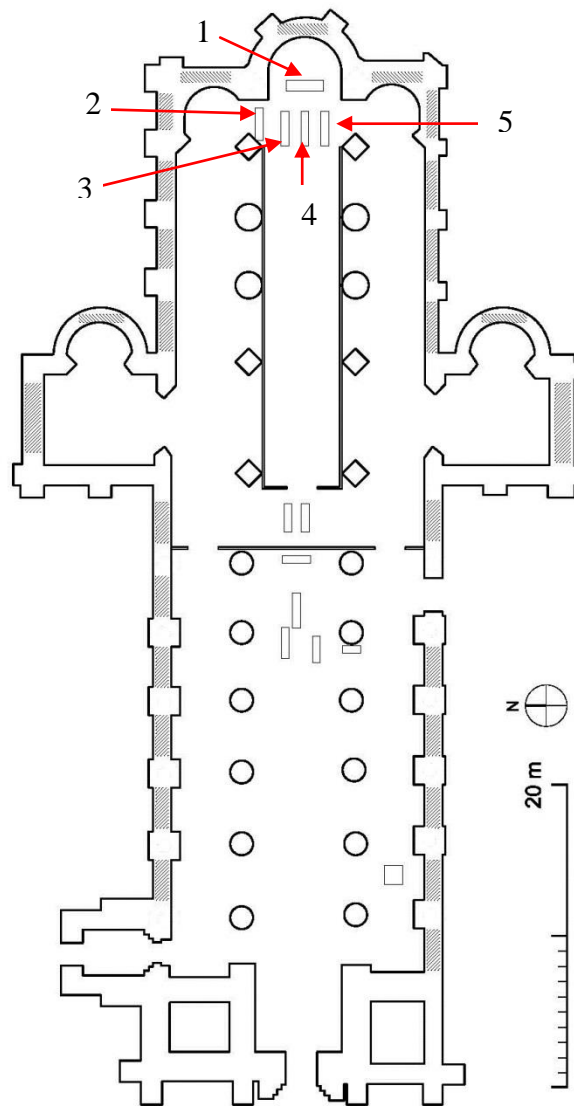

1. high altar; 2. Malcolm III's tomb; 3. St Margaret's tomb; 4. David I's tomb; 5. Malcolm IV's tomb

Plan 2(4). The transformation of the church at Dunfermline in the twelfth century

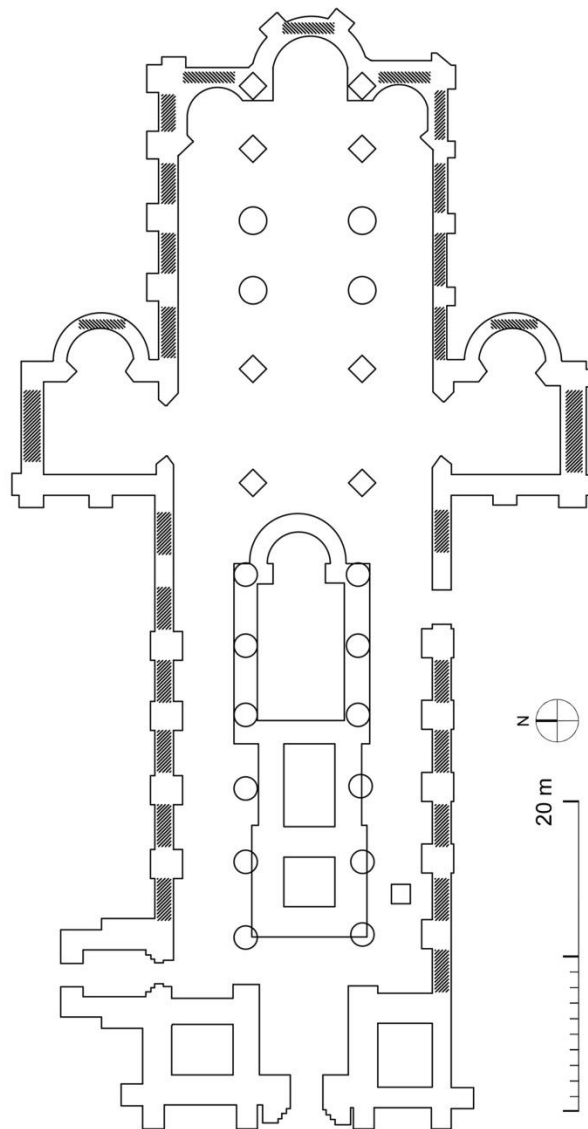

new church, and became the rood or nave altar of the enlarged church,<sup>112</sup> the tombs in the apse in the 'eleventh-century church' would have lain between the rood screen and the pulpitum in the new church. In this circumstance, to avoid the tombs being overlooked there,

---

<sup>112</sup> Eeles, 'The development and internal arrangement of the abbey church of Dunfermline', xxxi-xxxii.



the tombs would have been moved toward the nave side. It would have been easier to relocate the rood screen further east in order to place the tombs in the nave rather than to re-move the tombs to the west. After the translation of 1180, a new shrine was added to the list of cult foci, and thus pilgrims would have stopped there.

Concerning the architecture, although the church at Dunfermline had an association with Canterbury from the 1070s, it is unlikely that the architecture of the 'eleventh-century church' at Dunfermline was in any way influenced by Canterbury. Instead, it was influenced more by Durham and other northern English churches. It is not surprising that Durham exerted such an influence on Dunfermline, because the Scottish royal family already had an association with Durham from at least Malcolm III's reign. Moreover, the designer in charge of building works of the twelfth-century church of Dunfermline was Ailric, a master mason<sup>113</sup> who had been employed by Durham Cathedral and who, during the hiatus of building work there following the death in 1128 of Bishop Ranulph Flambard of Durham, might have been displaced to Scotland. As Neil Cameron concludes, the similarity between the south-east doorway of Dunfermline and the south-west nave doorway of Durham demonstrates that Dunfermline Abbey and Durham Cathedral had an association in architectural terms. Furthermore, the comparison could lead to speculate that the sculpture of the doorway of Dunfermline was carried out by the same mason or masons who undertook the carvings of the south west doorway of Durham. However, the great west doorway of Dunfermline Abbey shows little influence from Durham. Instead, the sculpture of the west doorway of Dunfermline Abbey demonstrates a closer connection to a number of Romanesque churches nearby Dunfermline, such as St Cuthbert's church at Dalmeny in West Lothian, St Giles' Cathedral in Edinburgh, St Athernase church at Leuchars in Fife, St Baldred church at Tynninghame in East Lothian, Kirknewton church in Mildlothian and Brechin Cathedral in

---

<sup>113</sup> *Registrum de Dunfermelyn*, nos. 35, 39.

Angus.<sup>114</sup> Yet in spite of this evidence it cannot be ruled out that the architecture at Dunfermline in the twelfth century shows the sign of the strong influence of Durham to Dunfermline.

In other words, Scottish royal association with Durham made it possible that a master mason and probably his followers were called to take part in construction at Dunfermline in the twelfth century. However, since a number of monks and first abbot at Dunfermline were from Canterbury, the liturgical practices of Canterbury would have influenced those of Dunfermline, although pre-existing practices might have remained. In addition, with the patronage of David I and under the abbacy of Abbot Geoffrey (1128-54) the small church at Dunfermline was transformed into a large Romanesque abbey,<sup>115</sup> so that the twelfth-century church at Dunfermline could provide the monks with appropriate space in which they prayed and celebrated the Benedictine liturgy as well as masses for a growing royal mausoleum which included three recognised as saintly. With the development of liturgical space, a number of stations where pilgrims could visit and pray emerged, which would also have encouraged the laity to make a pilgrimage to Dunfermline. Above all, until St Margaret's remains were translated to David's church in 1180, it seems that the nave functioned as parish church focused on keeping the cult foci, and in particular, the east end of the nave including St Margaret's tomb was strongly emphasised. The year 1180 would be a turning point in the devotional history of the laity/pilgrims at Dunfermline. Alongside St Margaret's shrine translated to the choir in 1180, it was in 'David's church' that David and Malcolm IV were buried, and David was regarded as a saint by the monks at Dunfermline, which meant that a St David's cult might also have been developed. Since 1180, the pivot of devotional practices of the laity at Dunfermline was moved to 'David's church' from the parish church.

---

<sup>114</sup> Cameron, 'The Romanesque Sculpture of Dunfermline Abbey', 65-78; Geoffrey Webb, *Architecture in Britain: the Middle Ages* (Baltimore, 1965), 53; Fernie, 'The architectural influence of Durham Cathedral', 269-76.

<sup>115</sup> ODNB accessed on <http://www.oxforddnb.com/index/10/101010531/>.

#### **(4) The Thirteenth Century church**

As discussed above, Dunfermline Abbey as a religious foundation had held a strong appeal for the Scottish kings during the reign of St Margaret's sons. In particular, David I made huge progress in establishing the veneration of Queen Margaret by raising the church at Dunfermline to abbatial status and building the twelfth-century choir there. Royal interest in Dunfermline Abbey lasted up to Malcolm IV's reign (1153-65). The reign of his younger brother, King William I (1165-1214), marked a turning point in royal patronage to the abbey, because William's interest was diverted to Arbroath Abbey which he founded in 1178 in honour of St Thomas Becket. This diversion of royal interest, however, does not mean that nothing further happened at Dunfermline regarding building operations. The translation of Margaret's remains to the new choir occurred in 1180, and was probably carried out by the monks of Dunfermline on their own initiative in response to the development of St Margaret's cult. This in turn resulted in increased demands from pilgrims to make easier access to the new shrine and the need for the monks to secure more space for liturgical services, which indicates that some architectural alteration were undertaken. Unfortunately no immediate reference concerning such operations is extant. There is, however, some evidence for construction operations at Dunfermline during the early thirteenth century. Construction work was certainly underway by 1226, when a papal bull issued by Pope Honorius III mentioned 'the augmentation of the monastery and the noble structure of extended fabric' at Dunfermline Abbey.<sup>116</sup> Pope Gregory IX also referred to the 'enlarged' and 'nobler structure' of the abbey in a bull of 1231.<sup>117</sup> The extended structure, as Ebenezer Henderson later suggested, was probably the continued building of the new choir. The erection of the new choir might have been to accommodate an increase in the number of monks, rising from 30 to

---

<sup>116</sup> *Registrum de Dunfermelyn*, no. 257.

<sup>117</sup> *Ibid*, no. 130.

50.<sup>118</sup> Moreover, given that building operations in the Middle Ages often extended over a number of years or decades because of financial difficulty or other reasons, it is possible that a programme launched for the 1180 translation was still underway in the 1220s and 1230s because the abbey lacked the funds to complete the project earlier. In addition to this speculation, there are other suggestions: firstly, to regain the abbey's pre-eminence and promote the cult of Queen Margaret, her formal canonisation was likely to be required. Therefore, the building works in the 1220s and 1230s might have been part of preparations to meet pre-requisites of an application for the official canonisation. Secondly, the increasing number of pilgrims and the more frequent occurrence of miracles could have produced more stations, and thus required the extension of the building. Thirdly, considering the status of Dunfermline Abbey as a daughter house of Canterbury, the building campaigns carried out at Dunfermline during the 1220s and 1230s might have been influenced by the 1220 translation of Thomas Becket at Canterbury, more specifically, by the building operations on the chapel of the Holy Trinity at the east end of the cathedral to where the translation of the archbishop's remains was made.<sup>119</sup>

Apart from the operation undertaken in the 1220s and 1230s, given the successful career of Robert de Keldelth, abbot of Dunfermline (1240-52) - who was also royal chancellor in 1250-1, a papal chaplain,<sup>120</sup> and the supervisor of the canonisation of St Margaret and the translation of the saint, it is likely that he launched a further building campaign in the early years of his abbacy. The construction operations, which might have been begun in the early 1240s, achieved the extension and remodelling of the eastern end of the church. This was the most significant building work at Dunfermline Abbey in the thirteenth century. Keldelth's construction scheme included the building of a feretory chapel,

---

<sup>118</sup> Henderson, *The Annals Of Dunfermline And Vicinity*, 69-73.

<sup>119</sup> Binski, *Westminster Abbey and the Plantagenets*, 94-5; B. Dobson, 'The monks of Canterbury in the later Middle Ages, 1220-1540' in Collinson, Ramsay and Sparks eds., *A History of Canterbury Cathedral*, 69-70.

<sup>120</sup> *ESSH*, ii, 563-4.

which according to the early fifteenth-century chronicler, Walter Bower, was consecrated in 1250.<sup>121</sup> However, as mentioned above, it took a long time to complete medieval building construction and consecration was sometimes undertaken before the completion of a building. Therefore, it is possible that construction of the feretory chapel lasted into the second half of the thirteenth century. Otherwise, there is a possibility that the building consecrated in 1250 had been begun in the 1220s and 1230s.

The royal interments also caused structural alteration in the church. Further royal burials, which had not taken place at Dunfermline since the burial of Malcolm IV in 1165, were held during the reign of Alexander III.<sup>122</sup> Alexander III might have been influenced by Louis IX's scheme to remodel his dynasty's monuments at St-Denis from 1263<sup>123</sup> - in fact, the reconstruction of St Denis was initiated in 1231. The French king's work perhaps affected the choice of location for the interments of Alexander's sons and wife. It is known that Alexander's wife, Queen Margaret was interred at Dunfermline in 1275, and that the king's sons, Princes David and Alexander were buried at Dunfermline in 1281 and 1284 respectively.<sup>124</sup> Alexander III might have arranged for their remains to be buried next to his own future tomb, that is, on the southern side of the choir aisle, near the presbytery.<sup>125</sup> In particular, given that burials of royal couples were a characteristic of the tombs at St-Denis, where 18 Carolingian and Capetian tombs were relocated at the command of Louis IX in the 1260s and rearranged by Philip IV in 1306-7,<sup>126</sup> Alexander III might have arranged the tombs of his family to follow the style of St-Denis. Therefore, the remains of Alexander's queen were perhaps buried adjacent to his planned tomb as a pair, rather than that she was buried

---

<sup>121</sup> *Chron. Bower*, v, 296-9.

<sup>122</sup> Boardman, 'Dunfermline as a Royal Mausoleum', 150.

<sup>123</sup> Penman, 'Royal piety in thirteenth-century Scotland', 24-5.

<sup>124</sup> *Chron. Bower*, v, 403, 409-11.

<sup>125</sup> *ESSH*, ii, 692.

<sup>126</sup> Brown, 'Burying and unburying the Kings of France', 246-9; Alain Erlande-Brandenburg, *Le Roi Est Mort: étude sur les funérailles les sépultures et les tombeaux des rois de France jusqu'à la fin du XIII<sup>e</sup> siècle* (Droz, Genève, 1975), Planches, 26, 27; Hallam, 'Royal burial and the cult of kingship in France and England, 1060-1330', 374.

‘beside King David’, as Bower’s description only vaguely suggests.<sup>127</sup> In addition, at some place west of the tombs of Alexander III and Queen Margaret, the remains of Princes Alexander and David were probably laid.

Alongside these interments, there may have been other building works at Dunfermline promoted by Alexander III. There are some clues to support this possibility. The shrine base of the feretory chapel still remains, and was made of black fossiliferous Frosterley marble from County Durham. According to G.S. Gimson, it seems likely that black fossiliferous Frosterley marble was brought from County Durham to make a new funeral effigy of William I at Arbroath Abbey at Robert I’s command in 1315.<sup>128</sup> The *Exchequer Rolls* from the end of Robert’s reign indicate that white Italian marble was brought from Paris for Robert’s own tomb.<sup>129</sup> The commissioning of the tomb from France means, as Ian Fraser suggests, that it would have followed a similar form to French monarchs’ tombs in the late thirteenth and fourteenth centuries: a white marble effigy on a black marble slab.<sup>130</sup> From this suggestive evidence, it is possible to speculate as follows: a building campaign at Dunfermline Abbey was launched after the beginning of the St Denis reconstruction in the 1260s. Following the style of French monarchs’ tombs, Alexander III might have ordered the eleventh/twelfth-century tombs at Dunfermline to be reworked in white continental and black Frosterley marble, and the remaining shrine base in the feretory chapel might have been part of the construction. This operation had probably been disrupted by the outbreak of the war between Scotland and England (c.1296-c.1357), and was certainly renewed by Robert I. Moreover, the interments of Queen Margaret (d.1275), Princes David (d.1281) and Alexander (d.1284) at Dunfermline Abbey made the space crowded, which might have encouraged the extension of the church or at least led to recognition of the shortage of space. Therefore, it is a possibility

---

<sup>127</sup> *Chron, Bower*, v, 403.

<sup>128</sup> Gimson, ‘Lion Hunt: a royal tomb-effigy at Arbroath Abbey’, *PSAS*, 125 (1995), 901-16; *RRS*, v, 360.

<sup>129</sup> *ER*, i, 214.

<sup>130</sup> Fraser, ‘The Tomb of the Hero King’, 169-74.

that the Lady Chapel at Dunfermline, added to the north of the choir, was begun in the late thirteenth century.

Translation of the remains of a saint also led to an alteration of liturgical and devotional space. Translation began with the arrival of canons or monks at a saint's tomb in procession chanting litanies and carrying candles and the Cross. A saint's grave seems to be opened by masons, just as the tomb of St Augustine was opened at the translation of 1091 by masons.<sup>131</sup> St Margaret's grave was also dug up<sup>132</sup> presumably by masons. Churchmen who intended to have contact with the holiness of a saint's remains were required to undergo fasting and keep ritually pure. The holy work at a saint's tomb sometimes terrified the selected churchmen exhuming the body, because it was believed that saints would inflict punishment on those who disturbed their bodies without their blessing.<sup>133</sup>

After the coffin was opened, the relics were collected and kept in a secure place such as a sacristy, which was often placed on the north side of the chancel, for example, at Glasgow, Dunkeld, Corstorphine and Seton, or on the south at Whithorn and Arbroath.<sup>134</sup> An aumbry or a niche in the wall with a locked door could also have stored the relics. As to Dunfermline, the relic altar placed before the new shrine in the feretory chapel might have been used as a sacristy or at least a spot to keep the relics. In general, it was necessary to have a delay

---

<sup>131</sup> Sharpe, 'The Setting of St Augustine's Tradition, 1091', 6.

<sup>132</sup> *Chron, Bower*, v, 297.

<sup>133</sup> Nilson, *Cathedral Shrines of Medieval England*, 26-7. The remains of saints, according to their preservation, were classified into two types, corrupt or incorrupt. It was not uncommon for a corpse to be found incorrupt in the Middle Ages. The key reasons for this were that the majority of incorrupt remains were probably embalmed and sealed in an air-tight stone tomb. Another reason might stem from the medieval mentality concerning preservation. In the Middle Ages, corruption of a body was only accepted if the entire body was corrupt. Therefore, medieval officials could be astonished to see parts of saints' incorrupt bodies (*Ibid*, 28). Concerning the corruption of the body, the statement of Gervase of Canterbury demonstrated that: 'when the tomb of Archbishop Theobald, which was constructed of marble, was opened, and the stone coffin discovered, the monks who were present, thinking that he was reduced to dust, ordered wine and water to be brought, to wash his bones; but the upper stone of the coffin being removed, he appeared perfect and stiff, adhering together by the bones and nerves, and a small degree of skin and flesh. The spectators were surprised, and, placing him on the bier, thus carried him into the vestry as they had done Lanfranc, that the convent might determine what was proper to be done with them both. Meanwhile the story was divulged abroad, and many, on account of his unusual preservation, styled him St Theobald (*The Chronicle of the Reigns of Stephen, Henry II, and Richard I, by Gervase*, in *The Historical Works of Gervase of Canterbury*, vol. 1, ed. W. Stubbs, Rolls Series (London, 1879), 25-6).

<sup>134</sup> McRoberts and Holmes, *Lost Interiors*, 141-2.

between the exhumation and the translation. Since the duration of an exhumation ritual was unpredictable and the clergy dared not to make high profile guests wait for a long time, everything regarding a translation should be completely prepared on the night before the day of the translation. During the night, the relics could be given special treatment such as being washed by water or wine. A vigil was held during the night. That was intended to protect the relics from thefts as well as to provide time for dedicated prayers. The procession of the translation ceremony began generally at Terce, or about nine o'clock in the morning. The relics were moved by high status persons from where they had been placed during the vigil to a new shrine.<sup>135</sup> At the translation of St Margaret's remains in 1250/1, King Alexander III, his mother, Queen Mary de Coucy, seven bishops and seven earls and abbots were reported as present.<sup>136</sup> Even though the king (born: 4 September 1241<sup>137</sup>) was still in his minority, he participated in carrying the relics of St Margaret, along with chosen figures like 'the bishop and abbots.'<sup>138</sup> When the relics were translated into the new shrine, the new tomb was sealed up, the shrine was consecrated, a Mass was performed, and a sermon was preached, as the procedure of other translations demonstrated.<sup>139</sup> The translation of saints' remains provided a good opportunity to separate the bones, which could lead to multiplication of shrines. The typical type was a head shrine, which was freed from the body.<sup>140</sup> St Margaret's 'head shrine' might have been produced in the translation in 1250/1 and kept in the relic altar.<sup>141</sup>

The remains of St Margaret were reburied in 1250/1 at the new shrine in the feretory chapel. Richard Fawcett's detailed architectural analysis describes it as an aisle-less

---

<sup>135</sup> Nilson, *Cathedral Shrines of Medieval England*, 29-32.

<sup>136</sup> *Registrum de Dunfermelyn*, no. 348; *Chron. Fordun*, 295; *Chron. Bower*, v, 297.

<sup>137</sup> *Ibid*, 167.

<sup>138</sup> *Ibid*, 297-9.

<sup>139</sup> Nilson, *Cathedral Shrines of Medieval England*, 33.

<sup>140</sup> *Ibid*, 31-2 and 54-6.

<sup>141</sup> The head shrine was once possessed by Mary Queen of Scots. After her withdrawing to England, a monk obtaining the shrine carried it to the Scottish College at Douay. Then, its traces has been losing (Alan Butler, *The Lives of the Primitive Fathers, Martyrs, and other Principal Saints: Compiled from Original Monuments and Other Authenic Records* (Edinburgh, 1799), vol. vi, 156-7).



rectangular structure extended the width of two bays behind the squared off east end. It is presumed that in order to give pilgrims access to the shrine the new east end housed a full-height ambulatory, and there may also have been a new chapel at each of the aisle ends. To create an extension beyond the aisled choir, the newly built chapel was probably raised a little higher than the choir aisle, keeping the balance with the established church building.<sup>142</sup> Just as William the Englishman's building campaign in 1179 at Canterbury provided a relatively suitable amount of wall-surface for stained glass windows,<sup>143</sup> so raising the feretory chapel at Dunfermline as high as possible might have been intended similarly to secure more space for a programme of stained glass windows. Any stained glass windows at the new shrine of Dunfermline might have depicted the life and miracles of St Margaret, just as the stained glass windows of the 1220 shrine in the Trinity chapel of Canterbury Cathedral depicted those of St Thomas.<sup>144</sup> It is also possible that Malcolm III - wearing armour with a sword and a helmet on his head - and David I, both of whom were also regarded as saints, were depicted on the windows as one of St Margaret's miracle described.<sup>145</sup> This illustration might have caused the miracle recipient to see the image in the ecstasy of prayer.

---

<sup>142</sup> Fawcett, 'Dunfermline Abbey Church', 49-50.

<sup>143</sup> M.F. Hearn, 'Canterbury Cathedral and the Cult of Becket', *The Art Bulletin*, vol. 76, no. 1 (1994), 44; Harris, 'Pilgrimage, Performance, and Stained Glass at Canterbury Cathedral', 267.

<sup>144</sup> Sarah Blick, 'Reconstructing the Shrine of St Thomas Becket, Canterbury Cathedral' in Blick and Tekippe eds., *Art and Architecture of Late Medieval Pilgrimage in Northern Europe and the British Isles Texts*, 407-9; Stephen Lamia, 'The Cross and the Crown, the Tomb and the Shrine: Decoration and Accommodation for England's Premier Saints' in Stephen Limia and Elizabeth Valdez del Álamo eds., *Decorations for the Holy Dead: Visual Embellishments on Tombs and Shrines of Saints* (Turnhout, 2003), 39-42.

<sup>145</sup> *Miracula*, ch. 7.



Figure 8. Chapter Seal of Dunfermline Abbey.

Traces of eight symmetrically-placed marks can be found on the shrine base in the chapel, which corresponds with the depiction of the shrine from the late thirteenth-century Chapter seal of Dunfermline Abbey. The seal shows the shrine with a *châsse* supported by eight spiral columns, and a female figure, probably St Margaret herself, holding an open book,<sup>146</sup> which was possibly her miraculous gospel book. Pilgrims could reach the base of the shrine through the open space between the columns. The performances of pilgrims on and around the shrine included the actions of crawling, touching, kissing, and thrusting themselves into the shrine base.<sup>147</sup> The superstructure of the shrine, which was supported by the columns and was normally concealed and protected by a gilded wooden cover, was

<sup>146</sup> Henderson, *The Annals Of Dunfermline And Vicinity*, 70-1; See Figure 8.

<sup>147</sup> Lamia, 'The Cross and the Crown, the Tomb and the Shrine', 51.

revealed to the laity on feast days. The upper part of the shrine was placed high enough to be seen rising above the high altar reredos. St Margaret's birthing shirt might have been displayed above the shrine on special occasions. As the late thirteenth-century Chapter seal illustrates, St Margaret's miraculous gospel book would also have been kept in the relic altar, probably along with missals containing the text of the Masses for the year provided for each altar, a decorative obit book,<sup>148</sup> or the ornamental 'Ancient' materials of Dunfermline cartulary.

In addition, part of a stone bench along the inner face of the wall on the east and south sides of the chapel still remains. On the surface of the bench are the traces of three piscina basins for washing/blessing pilgrims, which presumably indicate the former existence of side altars at each one. If no more piscina basins other than the remaining these basins existed in the chapel, three piscina basins and in consequence, three side altars in the feretory chapel might have linked to the symbolic meaning of veneration of the Holy Trinity. Moreover, in the assumption that the chapel contained just three piscina basins along with three side altars, that is, two on the east side and one on the south, it is suggested that there was not enough space for a piscina basin with a side altar on the north side of the chapel due to the placement of Malcolm III's tomb, presumably on the north side wall, thus leading to the placement of three piscina basins with three side altars on the south and the east sides. Otherwise, to keep the spiritual balance between the north side wall including Malcolm III's tomb and the south and east side walls, two piscina basins with two side altars were possibly placed on the east side wall, the most spiritual side, and one on the south side wall. It is also possible that given no traces of drains connecting to the 'basins', all of them were not used as piscina basins: some of them or all of them might have functioned as offering receptacles. The provision of

---

<sup>148</sup> McRoberts and Holmes, *Lost Interiors*, 165; Yeoman, 'Saint Margaret's Shrine at Dunfermline Abbey', 87.

the bench was probably aimed at giving ease of access to the disabled and the infirm.<sup>149</sup> In this vein, it must be noted that pilgrims slept and kept vigil at the tombs of St Margaret, as mentioned in miracles stories of the *Miracula*.<sup>150</sup> Providing pilgrims with some comfort at the shrine indicates that the abbey authorities recognized the significance of the shrine as a pilgrimage site and expected pilgrims to flock to the shrine and to mix dust with water.

On the vault of the east-north nave aisle, there are traces of the depiction of SS Paul, Peter and Andrew (the feast day of SS Paul and Peter: 29 June, that of St Andrew: 30 November), and another unidentified figure, which is probably early sixteenth-century work.<sup>151</sup> Given that these three saints are the apostles and there were altars at Dunfermline for the dedication of SS Peter and Andrew, it is likely that the unidentified figure is also one of apostle and a saint to whom an altar was dedicated, that is, probably St John. If this interpretation can be accepted, the depiction of St Paul, in spite of no altars at Dunfermline dedicated to the saint, was presumably relevant to the saint's status as an apostle. In addition, it cannot be ruled out that the illustration of St Paul was perhaps linked to his role as a sort of theologian of the Trinity. For example, the saint said that 'Grace and peace to you from God our Father and the Lord Jesus Christ..... Praise be to the God and Father of our Lord Jesus Christ..... Having believed, you were marked in him with a seal, the promised Holy Spirit [Ephesians 1:2-13]', and 'I keep asking that the God of our Lord Jesus Christ, the glorious Father, may give you the Spirit of wisdom and revelation, so that you may know him better [Ephesians 1:17].' However, all churches dedicated to the Holy Trinity did not show their dedication to St Paul.

---

<sup>149</sup> *Ibid*, 84-7; Yeoman, *Pilgrimage in Medieval Scotland*, 72-4.

<sup>150</sup> *Miracula*, chs. 4, 12, 17, 18, 24, 26, 27, 34, 41, 42.

<sup>151</sup> Fawcett, *Scottish Medieval Churches*, 325; see Figure 9.



Figure 9. Dunfermline Abbey, the paintings on the vault of the east-north nave aisle.

According to Francis C. Eeles, Dunfermline Abbey possessed a high altar in the conventual church and other altars: the altar of our Lady of Pity (mentioned between 1502 and 1504 in *The Burgh Records of Dunfermline*) on the west side of the transept in the conventual church; the Lady altar in the Lady Chapel; and at the back of the High altar screen the relic altar (1489) which housed the relics of St Margaret. These relics were kept safely there, and were probably displayed on St Margaret's shrine on special occasions. In the parish church there were the rood altar; and the altar of St Margaret in the south aisle, along with several other altars such as the altars of St Nicholas (mentioned 1500-1530 in *The Burgh Records of Dunfermline*), St Ninian (1501-27), St Salvator (1492-1504) and the Holy Blood (1502-19). In addition, Eeles insists that other lesser altars existed in the abbey. Apart from the altar of St Mary mentioned in the *Exchequer Rolls* of 1329 and 1388, *The Burgh Records of Dunfermline* records further altars, even if their locations are not referred to in detail: e.g. the altar of St Ursula mentioned in 1522 was placed in one of the aisles of the choir. In the conventual church, there were also altars of St John (mentioned between 1491 and 1506); St Andrew (1511); St Peter (1490-1506); St Benedict (1504-16); St Cuthbert (1508-20); St Michael (1505-11); St Stephen (1506-28); St Catherine (1492-1528), the dedication of this saint might have linked to the St Catherine's almshouse; St Laurence; and Corpus Christi.<sup>152</sup>

It should be noted that the first date when an altar was mentioned does not mean that the altars were only then being set up. Taking into consideration Alison Binns' survey of the dedications of monastic houses in England and Wales between 1066 and 1216, most of the

---

<sup>152</sup> See Plan 3. Eeles, 'The development and internal arrangement of the abbey church of Dunfermline', xxxix-xliii. However, it is noted that a dedication does not necessarily mean a separate altar. In large churches with multiple altars, several could also have multiple dedication with completely separate chaplainries attached: for example, in the case of St Giles in Edinburgh, a chaplainry of St Peter at St Andrew's altar, and of St Columba at the altar of SS Martin and Thomas (George Hay, 'The late medieval development of the High Kirk of St Giles, Edinburgh' *PSAS*, 107 (1975-76), 254-5). For St Catherine's almshouse at Dunfermline see Cowan and Easson, *Medieval Religious Houses: Scotland*, 164.

saints named as altar dedications at Dunfermline Abbey belonged to the list of principal patron saints of the Benedictine order. The most important patron saints of the Benedictine houses, according to Binns, were the Blessed Virgin Mary, St Peter, the Holy Trinity, St Michael, St Andrew, St James, St Nicholas, St Mary Magdalene, St John the Baptist, St George, St Leonard, St Cuthbert, St Martin, St Bartholomew, St Margaret, St John the Evangelist, the Holy Saviour, St Giles, All Saints, St Laurence, St Edmund, St Guthlac, St Hilda, St John of Beverley, St Felix, St Benedict and St Paul.<sup>153</sup> As a house of the Benedictine order, Dunfermline Abbey might have found it difficult to deviate far from the trends of the order in terms of dedication. Many saints with altar dedications at Dunfermline correspond with the saints listed in the Binns' survey: St Nicholas, St Mary, St John, St Andrew, St Peter, St Benedict, St Cuthbert, St Michael and St Laurence. Given that these saints were amongst the principal patron saints of the Benedictine order in England and Wales between 1066 and 1216, the altars dedicated to these saints at Dunfermline perhaps dated to at least one or two centuries earlier than their first mention in *The Burgh Records of Dunfermline*. As to other saints with altar dedications at Dunfermline, that of St Ninian was probably linked to local particularity, and, again, of early date.<sup>154</sup>

From the twelfth century onwards, it became the norm that all monks were also priests and they should say at least one Mass daily: this necessitated a number of side altars. Monks had little time to say Mass, which was available only from 9 a.m. after the morrow Mass to 11 a.m. before the high Mass. Therefore, in a community with 30 priests/monks or more, at least ten side altars were demanded.<sup>155</sup> In this context, the number of monks in a religious house could hint at the number of side altars there. According to Ebenezer Henderson who has suggested the number of monks at Dunfermline Abbey at certain moments, 13 monks

---

<sup>153</sup> Binns, *Dedications of Monastic Houses in England and Wales, 1066-1216*, 34-5.

<sup>154</sup> *Ibid.*, 39-49. Outside Dunfermline Abbey there is St Ninian's Chapel in Dunfermline, which was founded in the mid-fifteenth century (Erskine Beveridge ed., *The Burgh Records of Dunfermline*, xxvii).

<sup>155</sup> Klukas, 'The Architectural Implications of the *Decreta Lanfranci*', 149; Nilson, *Cathedral Shrine of Medieval England*, 80.

came from Canterbury to Dunfermline in 1124; in 1201, there were 25 monks and 12 officials at Dunfermline Abbey; in 1231, 50 monks; in 1301, 50 monks along with about 50 other residents including a number of novices learning ‘the art of theology’ and about 12 lesser officers, stewards and domestics; in 1401, 45 monks with about 15 support people including at least 12 officials related to the abbey’s domestic economy; in 1501, 38 monks and 12 officials.<sup>156</sup> From Henderson’s suggestion, it can be speculated that from the second quarter of the thirteenth century until the pre-Reformation at least 15-17 side altars were maintained at Dunfermline Abbey, the number of which almost corresponds with Eeles’ list indicating some twenty-two altars. However, since some of these altars might have been set up in the later fifteenth and sixteenth centuries, altars founded before the fifteenth century would probably have numbered less than 22.

During the period between 1150 and 1400 church altars could be situated in the nave of the church against pillars, along the side walls, or inside chapels. Side altars placed on the surface of nave pillars normally had painted retables as a backdrop on the west side of the pillars. For instance, each square pillar in the abbey church of St Albans bore an illustration of a saint crowned by a depiction of the Crucifixion.<sup>157</sup> The north and south aisle walls of the nave were also used for the placement of altars. Although altars at the walls of the nave might encounter difficulties with placing retables and similar decoration because of a lack of support from the rear against a wall, the general lack of space in churches led to the creation of a number of altars on the walls.<sup>158</sup> Other available space for the placement of side altars included the rood screen, which could be a backdrop for side altars. The eastern wall of a transept could also be the position for side altars. Further side altars were sometimes located in the sanctuary, which was generally the place for the main altar. Since the thirteenth century,

---

<sup>156</sup> *Chron. Bower*, iii, 147; Cowan and Eason, *Medieval Religious Houses*, 58; *Registrum de Dunfermelyn*, no. 130; Henderson, *The Annals Of Dunfermline And Vicinity*, 41, 65, 73, 107, 149, 183.

<sup>157</sup> Kroesen, ‘Recentring Side Altars in Medieval Church Interiors’, 150.

<sup>158</sup> *Ibid*, 152.



in some larger churches with shrines the sanctuary was surrounded on three sides by the narrow path called an ambulatory, through which the laity could reach the space behind the high altar. Side altars were placed against both the inner and outer walls of an ambulatory. In the thirteenth and fourteenth centuries, side chapels, which contained a piscina niche and a secure wall cupboard for the storage of the sacred vessels, also provided space for side altars.<sup>159</sup>

Scottish churches would have also followed these broad trends in terms of the location of altars. Although fifteenth and sixteenth-century examples, the liturgical arrangements of both Glasgow Cathedral and St Giles' Church in Edinburgh are known and might lend themselves to speculation about the location of altars at Dunfermline in the thirteenth and fourteenth centuries. At Glasgow, altars were placed in the chapels at the east end of the church, on both sides of the doorway in the pulpitum, and the west side of the pillars in the nave, along with the high altar and the rood altar.<sup>160</sup> While George Hay's plan of St Giles' Church in Edinburgh illustrating the pre-Reformation liturgical arrangements also indicates that altars were located at the eastern end of the church; in chapels, aisles and on the choir screen, one on each side of the screen doorway, and the transepts.<sup>161</sup> As to Dunfermline, as Plan 3 illustrates, altars might have been placed on the west side of the pillars in the nave; each side of the doorway in the choir screen; aisle pillars in the conventual church; the transept; the east end of the Lady Chapel after the fourteenth century; and the east end of the aisle in the conventual church. Along with these altars, it is known that there was a relic altar in the feretory chapel, a rood altar in the nave and the high altar in the choir.

---

<sup>159</sup> *Ibid*, 147-156. For the paintings on the nave pier at St Albans see Paul Binski, *Becket's Crown: Art and imagination in Gothic England 1170-1300* (New Haven and London, 2004), 72-3. For Retables in the English Gothic churches, Binski, 'Statues, Retables and ciboria: The English Gothic Altarpiece in Context, before 1350' in Kroesen and Schmidt eds., *The Altar and its Environment 1150-1400*, 31-46. For the Westminster Retable see Binski, *Westminster Abbey and the Plantagenets*, 152-67.

<sup>160</sup> 'Liturgical arrangements of Glasgow Cathedral in the fifteenth and sixteenth centuries' from C. A. Ralegh Radford, *Official Guide: Glasgow Cathedral* (Edinburgh, 1970).

<sup>161</sup> Hay, 'The late medieval development of the High Kirk of St Giles, Edinburgh', 255-8.

Plan 3. Location of side altars

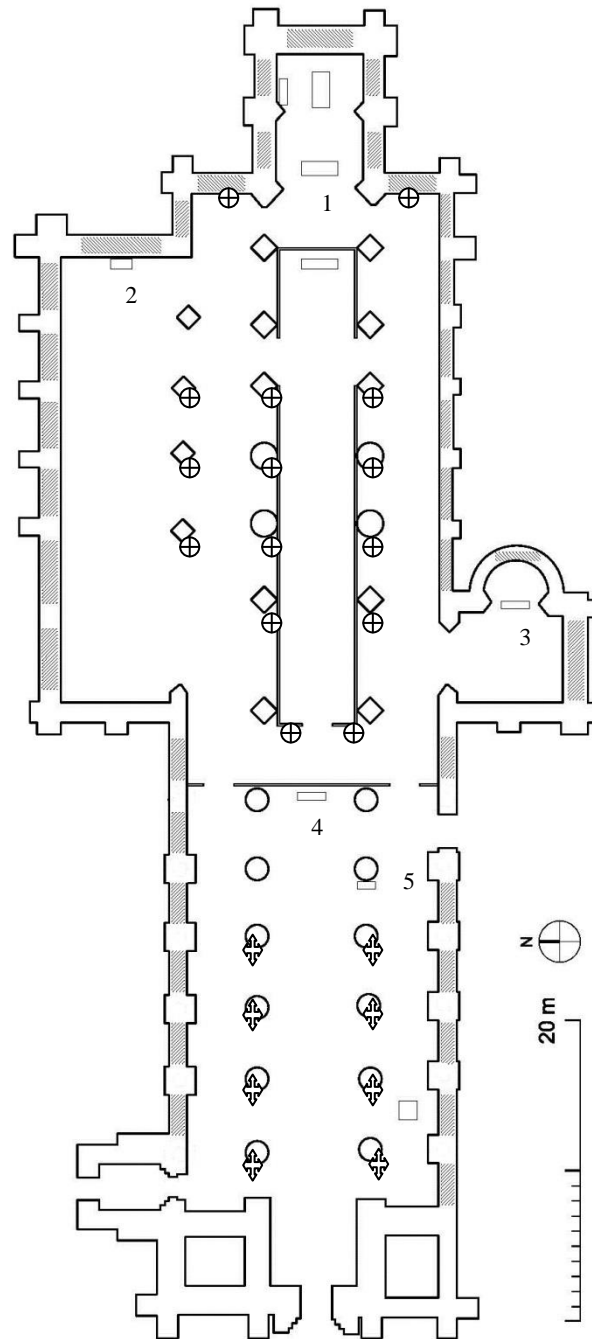

1. relic altar; 2.lady altar; 3. altar of our Lady of Pity; 4. rood altar; 5. St Margaret's altar; ⊕ possible locations for altars of St Mary, St Ursula, St John, St Andrew, St Peter, St Benedict, St Cuthbert, St Michael, St Stephen, St Catherine, St Laurence, Corpus Christi and St Thomas (?); ⊕ with figure possible locations for altars of St Nicholas, St Ninian, St Salvator, Holy Blood

The altars and their surroundings were to be kept clean. The standard of cleanliness would be maintained by a weekly inspection. At least three times a year they also had to be cleaned for major feasts. It was only in the tenth century that church altars were decorated other than by placing bread and wine on them for the Mass. Until the twelfth century even the candles and cross were positioned around and behind the altar rather than on it.<sup>162</sup> Moreover, even after the twelfth century it was forbidden to put a variety of images and candles on and around altars; the exception being an image of the saint to which the altar was dedicated, along with a cross in the middle and two candles to burn equally.<sup>163</sup>

Lights helped the priest read and deliver the text during the Mass. They also contributed to the visibility of the elevated Host to onlookers and so to their personal devotion during the sacrament. From the point of view of this function, it is normal that in the thirteenth century there were concerns about the absence of appropriate lights in chancels or around altars.<sup>164</sup> In fact, the need to place light on the altar had been discussed for a long time, reaching an agreement by the time of Innocent III (1160 or 1161-1216). In his *De missarum misteriis*, Innocent stated that ‘for Mass on feast days the altar is to have a cross and two candles to either side of it.’<sup>165</sup> Later a French canonist and liturgical writer called William Durand of Mende (c.1230-96) added that the candles were to be lit at the ordinary Mass. Thereafter, churches in England also followed the instruction of Innocent III with regard to lights on the altar, making regulations that one or two candles would be lit on the altar at ordinary Mass.<sup>166</sup> In particular, there was a variety of ways to place lights on and around the high altar. Louis Van Tongeren points out that the compilation of *Libri Ordinarii* in the Low Countries, which

---

<sup>162</sup> Louis Van Tongeren, ‘Use and Function of Altars in Liturgical Practice according to the *Libri Ordinarii* in the Low Countries’ in Kroesen and Schmidt eds., *The Altar and its Environment 1150-1400*, 269.

<sup>163</sup> Binski, *Becket’s Crown*, 174.

<sup>164</sup> *Ibid*, 157.

<sup>165</sup> *Patrologiae cursus completus, series latina*, ed. J.P. Migne, 217 vols (Paris, 1844-64), col. 799-802; Binski, *Becket’s Crown*, 156; D. R. Dendy, *The Use of Lights in Christian Worship*, Alcuin Club Collections, 41 (London, 1959), 48.

<sup>166</sup> *Ibid*, 49; Binski, *Becket’s Crown*, 156; A. Davril and T. M. Thibodeau eds., *Guillelmi Duranti: Rationale divinatorum officiorum*, 2 vols, (Turnhout, 1995-8), i, 43.

started in the twelfth century and contained detailed descriptions of the everyday liturgical celebrations for a religious foundation, described how the altar was decorated with lights. The significance of the feast determined how far the altar was ornamented with lights. For example, at Easter, Ascension and Pentecost the altar was illuminated with all candles. On ‘duplex feast days’, there were two large candles in front of the altar and two medium ones were put on the altar, while two candles were placed in the choir and three more were hung there. In addition to them, on ‘triplex feast days’, chandeliers with ten candles were hung on pillars around the altar, and a number of candles were placed in the choir and in front of it.<sup>167</sup>

Wealthy churches seemed to place two standard candles on the pavement in front of the altar. There were also lamps hung from the ceiling in front of the [high] altar. At the Elevation of the Host the ministries or the prominent laity carried ‘large twisted torches called serges.’<sup>168</sup> Dunfermline Abbey can be assumed to have followed these trends, at least in general terms. In spite of the scarcity of evidence regarding the arrangement of the lighting at Dunfermline Abbey, some provisions are mentioned in Dunfermline burgh records. In 1496 the records mention that ‘in primis the land of David Covpir beneith the tolbutth vij or ellis to uphold the little herss of vax’. The word ‘herss (hearse)’ in this record is usually used to indicate a ‘circular frame [of wood] to hold candles, hung from the roof.’<sup>169</sup> In addition, a charter of 1543 mentioned ‘two candles called ‘lie pretatis’ to be burnt annually at a requiem Mass’, and ‘the lamp before the altar of our Lady of Pity, near the dormitory stair.’<sup>170</sup>

There is also some evidence indicating that material was required to provide illumination in the church at Dunfermline. The *Exchequer Rolls* states that 562 stones 51bs of

---

<sup>167</sup> Van Tongeren, ‘Use and Function of Altars in Liturgical Practice according to the *Libri Ordinarii* in the Low Countries’, 269-70.

<sup>168</sup> Allan B. Barton, ‘The ornaments of the altar and the ministers in late medieval England’, in P.S. Barnwell, Claire Cross and Ann Rycraft eds., *Mass and Parish in late Medieval England: The Use of York* (Reading, 2005), 31-3.

<sup>169</sup> *The Burgh Records of Dunfermline*, 65 (page of the original MS); Eeles, ‘The Development and internal arrangements of the Abbey Church of Dunfermline’ in *Ibid*, xlv.

<sup>170</sup> *Ibid*, xlv.

wax were requested for candles and torches during the funeral of King Robert I.<sup>171</sup> In addition, The *Exchequer Rolls* mentioned the charges for gilding a hearse for Robert I's burial.<sup>172</sup> These facts demonstrate that the powerful illumination was needed at royal funerals. On 8 July 1321 Robert's charter announced that the cost would be paid for candles burning perpetually before St Margaret's shrine.<sup>173</sup> Alongside those examples, the only surviving Scottish medieval brass chandeliers dates to the fifteenth century and hangs in St John's church in Perth.<sup>174</sup> This permits us to speculate that a chandelier might also have been hung from the roof at Dunfermline Abbey. St Margaret's miracle story narrating that 'as she [St Margaret] returned, such a great Mass of lights shone in the choir as if the interior was full of innumerable lamps',<sup>175</sup> also provides a clue to estimate the significance of lights and windows in the choir.

Along with candles, textiles were also used for decoration of the altar. The altar was covered with textiles, including 'the pallium, mappa, manuterge, pannus, and antependium', which could be decorated with embroidered images, such as of white lions, cows, peacocks and crosses.<sup>176</sup> The frontal covered the front of the altar. In England, it was usually further divided into panels by the embroidered orphreys. The bottom and side parts of the altar might be decorated with colourful fringing, along with embroidery. Sometimes cloth frontals were replaced by painted wooden ones. The extent of decoration of the frontal varied according to each church. As a rule, wealthy churches would possess expensive frontals/cloths. For example, in the 1260s the frontal of Westminster Abbey was decorated with 'twelve ells of waxed canvas stitched with ...gold and silver thread, silk, pearls, 862 enamels and garnets in

---

<sup>171</sup> *ER*, i, cxxiv, 151, 232.

<sup>172</sup> *Ibid*, 193.

<sup>173</sup> *Registrum de Dunfermelyn*, no. 346; *RRS*, v, no. 188.

<sup>174</sup> David McRoberts, 'Material Destruction caused by the Scottish Reformation', *Innes Review*, vol. 10 (1959), 167; McRoberts and Holmes, *Lost Interiors*, 24.

<sup>175</sup> *Miracula*, 85.

<sup>176</sup> Van Tongeren, 'Use and Function of Altars in Liturgical Practice according to the *Libri Ordinarii* in the Low Countries', 270.

gilt settings.’ Four women worked to make it over three years, and they were paid £36 for their labour.<sup>177</sup> Turning to Scotland, there are early sixteenth century examples identifying the cost of some material to decorate altars. In January 1504, the cost of 24s. was paid for towels for the altar in the king’s closet in Holyroodhouse; and 5s. for silk for these towels.<sup>178</sup> In February 1504, Holland cloth (valued at 32s. 6d.) was provided to make frontals for the altar in Holyrood Abbey; Breton cloth (at 56s. 3d.) for the veil in the chapel of Holyrood; cloth (at 14s.) for the cross on the said frontals and veil; 5s. as labour charge for making the said crosses; and 18s. as labour charge for the said frontals, veil and placing of the crosses on them.<sup>179</sup> In particular, The *Exchequer Rolls* indicates that Robert’s queen, Elizabeth de Burgh paid 100s. for a new frontal of the altar of St Mary at Dunfermline c.1327.<sup>180</sup>

Apart from Queen Elizabeth’s granting the new frontal, there is no extant evidence concerning the decoration of the frontal at Dunfermline. Therefore, it is only possible to speculate about the decoration from other cases. According to David McRoberts, Scottish frontals decorated with embroidery survive from the late fifteenth century. Of them, in particular, the altar frontals of the Chapel Royal at Stirling were impressive. One frontal covering the front of the altar was blue damask decorated with the Salutation of Our Lady on a background of sun-rays woven with gold thread. A second frontal was embroidered with the Coronation of the Blessed Virgin, surrounded by angels and decorated with many pearls. Another contained an image of the Holy Trinity embroidered in gold thread and yet another, on blue taffeta, displayed an image of Christ on the cross, also embroidered in gold thread. The frontals of the high altar in King’s College, Aberdeen described the life of the Blessed Virgin Mary and carried the images of the Apostles Peter and John.<sup>181</sup> In addition, stories and

---

<sup>177</sup> Binski, *Westminster Abbey and the Plantagenets*, 152-3.

<sup>178</sup> *TA*, ii, 293.

<sup>179</sup> *Ibid*, 293-4.

<sup>180</sup> *ER*, i, cxxv, 239.

<sup>181</sup> McRoberts and Holmes, *Lost Interiors*, 46-7; F. C. Eeles, ‘The inventory of the Chapel Royal at Stirling, 1505: a new translation with introduction and notes’, *Transactions of the Scottish Ecclesiastical Society* 3

images illustrated on the frontals might suggest what objects or figures were venerated in the church. In this vein, it can be suggested cautiously that frontals for the high altar at Dunfermline Abbey might have been embroidered with the Holy Trinity and the image of Christ. Moreover, near the high altar and before the wax candle given by Abbot Richard de Bothwell (1444-68) a painting of St Margaret was furnished,<sup>182</sup> which perhaps replaced an earlier such painted altar image of the eleventh - thirteenth/fourteenth-century altar.

While the frontal covered the front of the altar, the top of it was completely covered with white cloths. The upper part of these cloths, which were sometimes decorated with embroidery and drawn thread style, also covered the sides of altars.<sup>183</sup> The altar could also be decorated with precious objects such as fully decorated gospel books and crosses, or other relics.<sup>184</sup> The extent of decoration of the altar and how the altar was decorated varied depending on each individual church and altar. However, the decoration of altars at Dunfermline might have not deviated from the general trend. Furthermore, the location of altars definitely affected the pilgrimage routes in a church. Since the pilgrims wanted to obtain divine favour, they would try to visit many sites in a church in order to request saintly intercession. In pragmatic terms, provision of a number of altars might give additional economic advantage to the church because of pilgrims' offerings given at these altars. Apart from liturgical function, such financial benefits could also have been a motive for multiple altars.

The extension of the church buildings at Dunfermline in the mid-thirteenth century provided more space for establishing more altars. In addition, it provided more space for the monks but also increased provision for pilgrims and, in consequence, the potential for

---

(1912), 319-21. Also worthy of note is the decorated frontals at St Salvator's College Chapel in St Andrews and King's College in Aberdeen (Ronald G. Cant, *The College of St Salvator* (Edinburgh and London, 1950), 160; Francis C. Eeles, *King's College Aberdeen* (Edinburgh and London, 1956), 31, 36).

<sup>182</sup> McRoberts and Holmes, *Lost Interiors*, 56; *Chron, Bower*, ix, 45.

<sup>183</sup> Barton, 'The ornaments of the altar and the ministers in late medieval England', 30-1.

<sup>184</sup> Tongeren, 'Use and Function of Altars in Liturgical Practice according to the *Libri Ordinarii* in the Low Countries', 270-2.

earnings from more offerings, and changed liturgical space. To understand the result of the architectural extension and its influence on liturgical practice at Dunfermline, the creation of tombs and the alteration of them should be noted. The *Miracula* said that the remains of Queen Margaret were translated to a site ‘on the north side of the high altar’ in the conventual church in 1180. There is no extant document with respect to the translation of King Malcolm III’s remains at the same time. However, Walter Bower’s mention of a miracle which occurred during St Margaret’s translation in 1250/1 which raises the possibility of the translation of King Malcolm’s remains at the end of the twelfth century or the early thirteenth century. Bower’s ignorance of the 1180 translation is revealed by the description in the *Miracula*. In particular, it reveals that his location of St Margaret’s grave before the 1250/1 translation was incorrect. In addition, the statement that Malcolm III’s tomb was placed in the north aisle of the nave cannot be accepted. The remains of St Margaret had been located in the choir since 1180, therefore the relics of St Margaret could not have passed a tomb in the nave at the time of the 1250/1 translation. This fact raises a question over where the grave of Malcolm III was at that time. Given that the 1180 translation was not mentioned, Bower might have relied on poor or inappropriate information about the translations of St Margaret, or confused them. However, his statement that ‘they solemnly placed both [the remains of St Margaret and Malcolm III] coffins in tombs which had been decked out elegantly for that purpose, on 19 June’<sup>185</sup> indicates that the remains of both St Margaret and Malcolm III were translated on the same day. Moreover, the phrase ‘both coffins in tombs which had been decked out elegantly’ points out that the coffins were prepared beforehand. If the remains of Malcolm III had been suddenly moved, as Bower described, following the advice which a witness initially suggested, it is presumed that there was no time to prepare well decorated coffin for Malcolm III’s relics. Therefore, as long as Bower’s statement concerning this point

---

<sup>185</sup> *Ibid*, 299.



is reliable, it can be suggested that the translation of Malcolm's remains was pre-planned, along with the translation of St Margaret's, and, in consequence, the miracle relating to the translation was presumably discredited. Bower or Dunfermline monks might have wanted to emphasize the holiness of St Margaret by 'inventing' the miracle story.

Regardless of whether the miracle occurred or not, the story describes the placement of Malcolm III's tomb on the north side of St Margaret's tomb as viewed from it at the 1250/1 translation. Considering that the grave of St Margaret at that time was placed in the choir, Malcolm's tomb was located in the north of the choir, that is, probably slightly out of the choir - near to St Margaret's remains in the 1180 shrine. If this interpretation is accepted, it can be concluded with caution that the remains of Malcolm III, who was also considered a saint,<sup>186</sup> had been moved to be near St Margaret's 1180 shrine at the end of the twelfth century or the early thirteenth century. Alongside the tombs of these two saints in the choir and slightly out of the choir, the location of the tomb of David I in the choir - who was also regarded as a saint by the monks of Dunfermline - means that 'three' saints symbolizing the veneration of the Trinity were brought together. Just as Malcolm III's tomb was placed near St Margaret's 1180 shrine, so Malcolm III's remains might have been translated to the 1250/1 new shrine of St Margaret in the feretory chapel and reburied next to St Margaret. His new tomb was probably inserted into the wall in the chapel.

David I was the first royal personage who was buried in the enlarged twelfth-century church choir. He was interred under 'the pavement in front of the high altar' in the newly extended choir in 1153.<sup>187</sup> David was followed by Malcolm IV, who was buried, according to Bower, 'in the middle of the floor, before the high altar, on the right of that of King David' in

---

<sup>186</sup> *Ibid*, iii, 71.

<sup>187</sup> *Ibid*, iv, 250; *John of Fordun's Chronicle of the Scottish nation*, 225.

Plan 4. The thirteenth century church (c.1250/1)

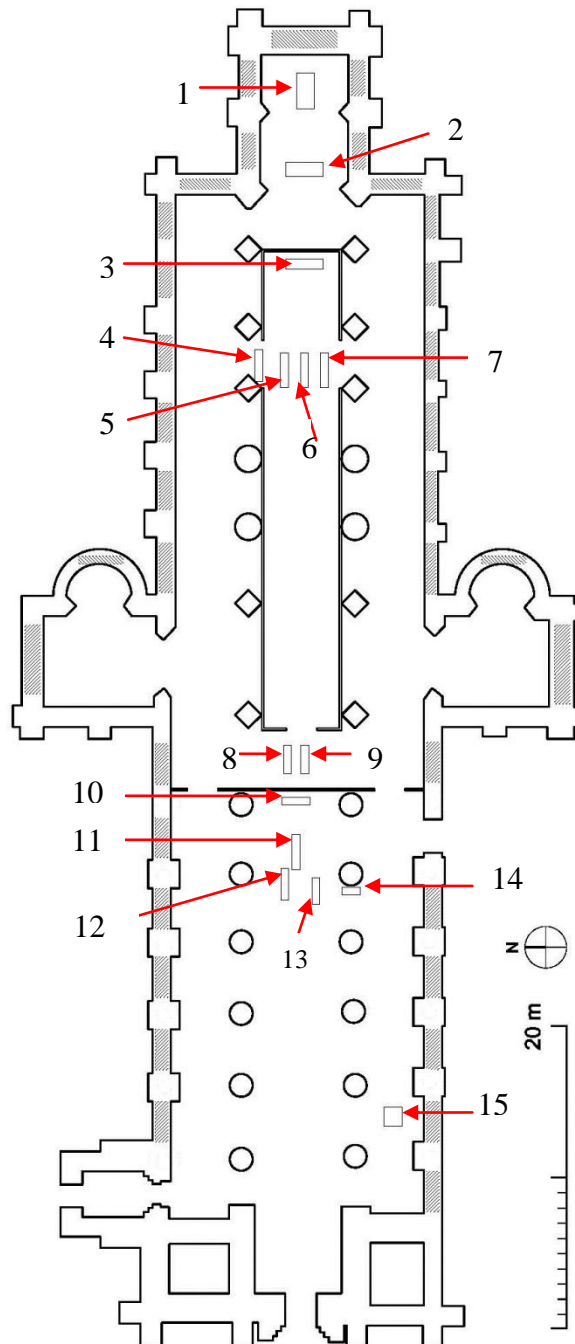

1. St Margaret's 1250/1 shrine; 2. relic altar; 3. High altar; 4. Malcolm III's tomb; 5. St Margaret's 1180 shrine; 6. David I's tomb; 7. Malcolm IV's tomb; 8. Malcolm III's empty tomb; 9. St Margaret's empty tomb; 10. rood altar; 11. St Margaret's original tomb; 12. Edgar's tomb; 13. Alexander I's tomb; 14. St Margaret's altar; 15. St Margaret's well

Plan 4(2). The thirteenth century church (1250/1-the early fourteenth century)

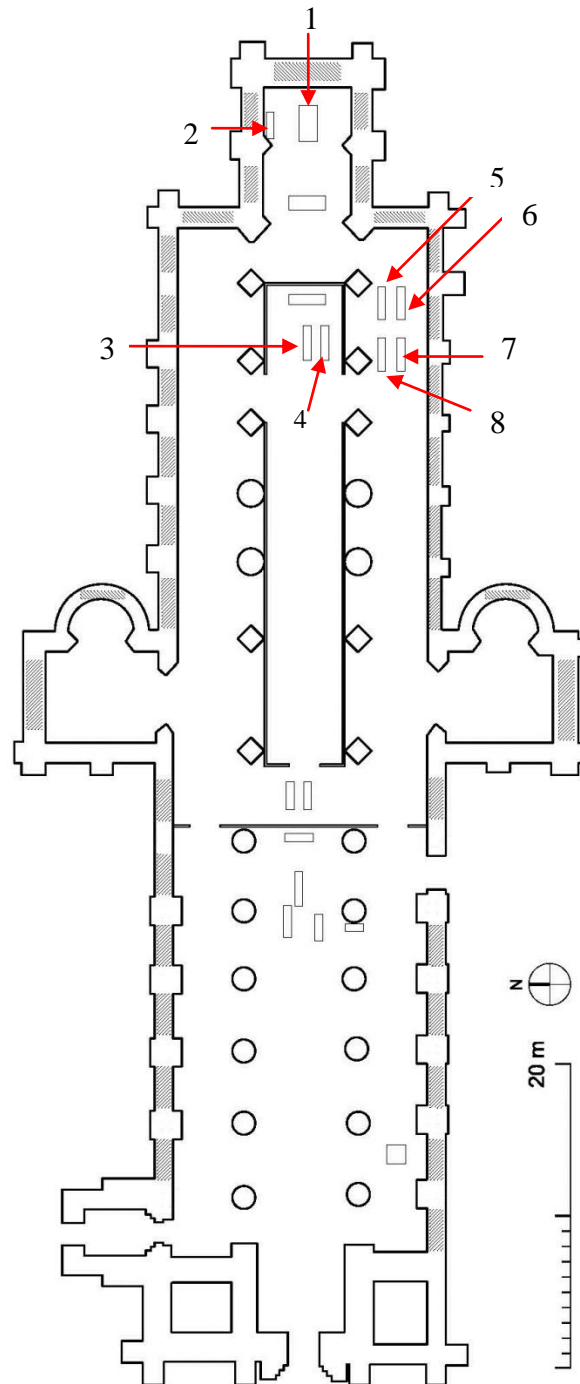

1. St Margaret's 1250/1 shrine;
2. Malcolm III's tomb;
3. David I's tomb;
4. Malcolm IV's tomb;
5. Alexander III's tomb;
6. Queen Margaret's tomb;
- 7 and 8: tombs of Princes David and Alexander

1165.<sup>188</sup> With the construction of a feretory chapel in the mid-thirteenth century, the high altar was moved a bay eastwards, in consequence, the choir was also extended. However, it seems that behind the high altar some space was needed for an ambulatory. This means that the space for the movement eastwards of the high altar was restricted, and that, in consequence, the space for the choir was also constrained, even if the physical structure had been extended. Given that the area before the high altar was regarded as the most honourable site, it was the suitable burial-place for a founder of the abbey. Therefore, the extension of the feretory chapel, which led the high altar to move a bay to the east, might have caused the remains of David I and Malcolm IV to be moved one or two bays to the east. Therefore, the choir at Dunfermline between the 1180 translation and the 1250/1 translation seems to have contained the 1180 shrine of St Margaret and the tombs of David and Malcolm IV. The tomb of Malcolm III was probably located next to the 1180 shrine of St Margaret, slightly out of the David's choir. After 1250/1 the empty tomb of St Margaret and the new graves of David and Malcolm IV might have existed in the choir, along with the old empty graves of David and Malcolm IV. In addition, since the remains of Malcolm III were perhaps moved next to the 1250/1 shrine of St Margaret in the feretory chapel, the tomb of Malcolm III placed next to the 1180 shrine of St Margaret might also have become an empty tomb.

In fact, it is not uncommon for empty graves to be recycled. For example, at Winchester, after the remains of St Swithun were translated, his empty tomb was reused as a burial site until the Reformation. At Westminster, in 1272 Henry III was buried in the tomb in which St Edward himself had been interred until his translation to his own new shrine. Even if an empty grave was not used for another dead figure, it was often considered to keep the sanctity of its original owner, as the pilgrims continued to visit the empty grave of St Thomas

---

<sup>188</sup> *Ibid*, 254; *Chron. Bower*, iv, 280.

at Canterbury.<sup>189</sup> In the same context, it is more likely that the empty tomb of St Margaret - the 1180 shrine- was used as a cult site rather than that taken by another occupant. Given that David I was also regarded as a saint, his empty tomb was perhaps assumed to play a role as a cult focus.

---

<sup>189</sup> Crook, 'Aspects of Relic Cults', 16; John Steane, *The Archaeology of the Medieval English Monarchy* (London, 1998), 48; Binski, *Westminster Abbey and the Plantagenets*, 94; Lamia, 'The Cross and the Crown, the Tomb and the Shrine', 42.

## **(5) The Fourteenth century church**

The fourteenth century also saw building programmes at Dunfermline. The reconstruction and extension of the refectory and guest house is known to have been carried out under Robert I's patronage. In addition to these building works, the most significant operation was the erection or completion of the Lady Chapel,<sup>190</sup> which provided a space originally for daily Masses to the Virgin Mary and for lay attendance.<sup>191</sup> From the mid-eleventh century onwards, the Marian cult had developed and, according to Rachel Fulton, the growth of the cult was attributed to the Virgin Mary's story, representing the appropriate human response and expressing the love that a human being was capable of when thinking about and gazing at the face of the God-man, Jesus Christ and his sacrifice.<sup>192</sup> In the same vein, Anselm of Canterbury's prayers to Mary, which were considered as significant as his prayers to Christ, can be understood: 'they spoke immediately to the contemporary anxiety over the coming of Christ in Judgement through an impassioned appeal to the image of Mary as Intercessor.'<sup>193</sup> Scottish churches followed the trend in devotion to the Virgin Mary from the early twelfth century. As Matthew Hammond points out, at least 80% of Scottish religious houses founded between 1124 and 1250 were dedicated to the Virgin Mary. During the same period of time, at least 15 Scottish monastic foundations excluding monasteries in Galloway and Argyll were established and dedicated exclusively to Mary. 12 religious foundations

---

<sup>190</sup> Alongside the fourteenth century building operations, the fifteenth century sees the further refurbishment of the abbey building. This included the rebuilding of the north-west tower, adding a two-bay porch above the north doorway, rebuilding a large part of the north arcade's western bays in the nave, new ceiling arches over the three western bays of the north aisle, and also probably inserting the small lancets into the gallery, west of the crossing in bays four to six (Nick Bridgland, 'Dunfermline Abbey: Cloister and Precinct', 94-7; Fawcett, 'Dunfermline Abbey Church', 52.).

<sup>191</sup> Binski, *Westminster Abbey and the Plantagenets*, 10.

<sup>192</sup> Rachel Fulton, *From Judgment to Passion: Devotion to Christ and the Virgin Mary, 800-1200* (New York, 2002), 61-4.

<sup>193</sup> *Ibid*, 199-200, 204.

were dedicated to Mary, alongside one or more other saints such as Uinniau (Finnian), Machutus, Machar, Serf, Andrew, James and John the Baptist.<sup>194</sup>

The development of Marian devotion led to the building of the Lady Chapel, which was usually located at the extreme north-east of a church.<sup>195</sup> The addition of new buildings at the east end of a church including the erection of the Lady Chapel was a popular trend in England after c.1200. In large English churches, a new eastern arm was often developed: at Salisbury in the 1220s; Durham and Ely in the 1230s; Westminster in the 1250s.<sup>196</sup> The abbey church at Dunfermline could have been influenced by these examples, along with the demand for the Marian devotion. Thus, this led to the addition of the five bay Lady Chapel on the north-east side of the choir.<sup>197</sup> The original design of the chapel is unknown. However, the engraving in Francis Grose's *Antiquities of Scotland* published in 1791, shortly before the choir's demolition in 1818, illustrated that the chapel was lit by large traceried windows that filled the space between the buttresses.<sup>198</sup> In addition, since the chapel was an open space internally, its stained glass windows could provide additional light to the high altar, which was the centre of the church and should be clearly visible.<sup>199</sup> As discussed above, the abbey church at Dunfermline required more space for royal interments in the last quarter of the thirteenth century with the deaths of royal family members including Queen Margaret (d.1275), and Princes David (d.1281) and Alexander (d.1284). To accommodate the need for more space for royal burials, the erection of the Lady Chapel might have been launched at the end of the thirteenth century and probably progressed slowly because of the outbreak of the

---

<sup>194</sup> Hammond, 'Royal and Aristocratic Attitudes to Saints and the Virgin Mary in Twelfth and Thirteenth century Scotland', 72-4.

<sup>195</sup> Nilson, *Cathedral Shrines of Medieval England*, 77.

<sup>196</sup> Penman, 'Robert I (1306-1329)', n. 84; T. Tatton-Brown, 'Canterbury and the Architecture of Pilgrimage Shrine in England', 97-8.

<sup>197</sup> The location of Lady Chapel on the north side of the choir was seen at the cathedrals of Ely and Peterborough. Lady Chapels at Dunblane and Dunkeld Cathedrals might have been placed on the north nave aisles (Fawcett, 'Dunfermline Abbey Church', 51).

<sup>198</sup> Francis Grose, *Antiquities of Scotland*, vol. ii (London, 1791), 288 [Dunfermline Abbey Plate II].

<sup>199</sup> Connell, *Church Building and Furnishing*, 23-4.

war in 1296. Until the Lady Chapel was built, the altar of St Mary, to which Robert's queen, Elizabeth de Burgh paid for a new frontal,<sup>200</sup> and which was presumably located at the east end of the north choir aisle, might have functioned as a station for the worship of the Virgin. Moreover, in an assumption that the altar of our Lady of Pity on the west side of the transept in the conventual church had been existed prior to the erection of the Lady Chapel, the altar would also have played a role in the worship of the Virgin Mary.

There is some evidence suggesting that building operations such as the erection of the Lady Chapel and the reconstruction of the refectory were supported by Robert I. On 22 July 1326 he granted Dunfermline the right to use a cocket seal,<sup>201</sup> which was probably intended to provide the monks with income from customs for the construction of the Lady Chapel and the refectory. On 21 October 1326 a general Chapter of Benedictine monks was held at Dunfermline, at which there was an attempt to annex Coldingham Priory to Dunfermline.<sup>202</sup> This move might also have been intended to provide potential income for the building works at Dunfermline - in the end the attempt was not carried out. In particular, Robert I may be said to have developed the construction of the Lady Chapel further to make more space for the burials of his family and close followers, just as Edward I offered his patronage to Westminster c.1270-90 for the tombs of his family, relatives and crucial supporters. It seems likely that Thomas Randolph, earl of Moray (d.1332); Sir Andrew Moray of Bothwell (d.1338) who was the third husband of Robert's sister Christina, and Christina herself (d.1356/7); and Robert's daughter, Matilda (d.1353) were all buried in the Lady Chapel at Dunfermline.<sup>203</sup> A grant of Thomas Randolph, earl of Moray, one of Robert I's kinsmen and closest followers, to Dunfermline for Masses in the Lady Chapel for the sake of the souls of

---

<sup>200</sup> *ER*, i, cxxv, 239.

<sup>201</sup> *RRS*, v, no. 303.

<sup>202</sup> *Ibid*, 590.

<sup>203</sup> Boardman, 'Dunfermline as a royal mausoleum', 150. For Thomas Randolph, Matilda and Christina see *Chron. Bower*, vii, 65, 275, 305. For Sir Andrew Moray see *Chron. Fordun*, i, 363; Penman, 'Robert I (1306-1329)', 37; Penman, *David II*, 'Genealogical Table', xiv.



King Robert, the Virgin, the Trinity and St Margaret in *c.* 1327<sup>204</sup> can provide a clue to see Robert's intention concerning the development of the Lady Chapel for the burial place of his wider family and major followers. Later on, the Lady Chapel as a name implies femininity so that the chapel might be regarded as an especially suitable place for the burials of queens. Queen Euphemia (d.1387) and Queen Annabella Drummond (d.1401) for certain were later interred there. Queen Euphemia or Queen Annabella could have been buried in the tomb which in 1368 David II's queen, Margaret Logie (née Drummond, Annabella's aunt) had commanded to be prepared for the queen herself.<sup>205</sup> Robert, duke of Albany (d.1420), was the last royal figure to be buried at Dunfermline.<sup>206</sup> Although he was only a relative of Robert Bruce through descent from the king's daughter Marjory, he might have been laid to rest in the western part of the Lady Chapel. On the other hand, the eastern part of the chapel would have been allotted for the burials of the family members of Robert Bruce.

The Lady Chapel might have been completed in the later fourteenth century, as part of the refurbishment of the eastern part. The *Exchequer Rolls* recorded that Margaret Logie, who was the second queen of David II and died at Marseilles on her way to the pope at Avignon *c.*1373 after her divorce from David, purchased marble at the cost of £10 in 1368 to prepare for her own tomb at Dunfermline.<sup>207</sup> Given the cost,<sup>208</sup> the marble was likely to have been for only a small part of the whole tomb. In addition, her preparation of her own tomb at the royal mausoleum mirrored her wish to sustain the marriage with her husband, which had been unstable due to her failure to provide issue. Therefore, she may have sought the apotropaic power of St Margaret to preserve her marriage, which might have led to an

---

<sup>204</sup> *Registrum de Dunfermelyn*, no. 357.

<sup>205</sup> *ER*, ii, 300, 348; *Registrum Episcopatus Glasguensis*, ii, nos. 304-8; Boardman, 'Dunfermline as a Royal Mausoleum', 150.

<sup>206</sup> *Ibid.*, 150.

<sup>207</sup> *ER*, ii, 300. For Margaret Logie see Michael Penman, 'Margaret Logie, Queen of Scotland' in Elizabeth Ewan, Sue Innes, Sian Reynolds and Rose Pipes eds., *The Biographical Dictionary of Scottish Women: From the earliest times to 2004* (Edinburgh, 2006), 248-9; *Chron. Bower*, vii, 359.

<sup>208</sup> Robert I's marble tomb was supposed to cost £1,000 or more, and £682 was paid for Robert II's resting place at Scone Abbey in 1390 (*ER*, i, 450-1; Penman, *David II*, 60, 412).

attempt to take out part of St Margaret's shrine to use it for part of her own tomb. For this purpose, she would have intended to replace part of the saint's shrine stone with the marble stone being purchased in 1368. Furthermore, a single unbroken piece of stone - approximately eight feet in length - is preserved at Dunfermline. This stone, given its proportions, is likely to be part of an elite tomb base,<sup>209</sup> perhaps being separated in the course of translation of the marble. These scant surviving evidences - the purchase of marble in 1368 and a single unbroken piece of stone - lead to speculation that the eastern part of the church was perhaps reorganized or refreshed in the later decades of the fourteenth century, and that the completion of the Lady Chapel was probably part of this refurbishment. Apart from the speculation based on the limited evidence, Richard Fawcett from the architectural detail point of view also suggests that the chapel was probably completed in the late fourteenth century, when the form of window tracery showing intersecting arcs within circles, which was possible from the late thirteenth century, became popular at several Scottish churches including the cathedrals of Elgin and Fortrose.<sup>210</sup>

In this vein, several grants of David II to Dunfermline Abbey in 1363 might have supported the reconstruction including the addition of the Lady Chapel: on 4 August 1363 the king gave the abbey the land of Garnekere and Tillicoultry with a mill-house at the latter, both in the sheriffdom of Clackmannan;<sup>211</sup> on 24 October he confirmed that the burgesses and merchants of the abbey had the liberty of buying and selling within the bounds of the regality of the abbey and in the burghs of Dunfermline, Kirkcaldy, Musselburgh and Queensferry. On the same day, David also confirmed that the abbey had a port at the grange of Gellet or at West Rosyth.<sup>212</sup> These grants, along with the intention to help the refurbishment, might have been relevant to David's desire to secure the power of St

---

<sup>209</sup> Penman, 'A Programme for Royal Tombs in Scotland?', 242.

<sup>210</sup> Fawcett, 'Dunfermline Abbey Church', 51; Fawcett, *Scottish Medieval Churches*, 121-3.

<sup>211</sup> *RMS*, i, no. 144 and App. ii, no. 1444; *Ibid*, i, no. 145 and App. ii, no. 1446.

<sup>212</sup> *Registrum de Dunfermelyn*, nos. 390-1.

Margaret's 'birthing shirt' in hope of a pregnancy for his new wife Margaret Logie, whom he had married at Inchmurdoch in Fife in May of that year.<sup>213</sup>

While the major building operation at Dunfermline in the fourteenth century was the erection of the Lady Chapel, the most lavish funeral performed there during the same period of time was that of Robert I.<sup>214</sup> Only the French chronicler, Froissart specified the date of Robert's funeral: 7 November 1327. However, given the death of the king at Cardross on 7 June 1329, the date, in particular, the year mentioned by Froissart, as Dunbar pointed out, is likely to be in error; or Froissart could have confused the funeral of Robert with that of Queen Elizabeth (d.26 October 1327).<sup>215</sup> In spite of this confusion, Froissart's specification of the date of the funeral indicates that the funeral was held five months after Robert's death. The delayed funeral led definitely to the embalmment of the dead king's body to prevent it from corruption.

Robert has been believed to have been buried in front of the supposed high altar of the fourteenth-century church, since two large flat slabs of different sizes - 'the one on the west forming the head stone of the vault, which measured in breadth 28½ inches, and in length 18 inches, the lower one six feet in length, and 28½ inches in breadth' - were found there in 1818 and the skeleton in the lead coffin under the slabs was examined in 1819.<sup>216</sup> In particular, based on the condition of the skeleton's chest - 'the most remarkable circumstance which we observed.....was the state of the sternum, which we found had been sawed asunder longitudinally from top to bottom', presumably - heart removal, which was the most reliable

---

<sup>213</sup> *Chron. Fordun*, i, 382; *Chron. Bower*, vii, 323-9.

<sup>214</sup> Fragments of evidence from the *Exchequer Rolls* make it possible to conjecture how splendid the funeral was carried out (*ER*, i, 150, 151, 213, 214, 215, 221, 232, 288).

<sup>215</sup> Dunbar, *Scottish Kings*, 140; Duncan ed., *The Bruce - John Barbour*, 756, n. 301. For the death of Queen Elizabeth and Robert I see *Chron. Bower*, vii, 35, 45; *Chron. Fordun*, i, 353.

<sup>216</sup> H. Jardine, 'Extracts from the report made by Henry Jardine, Esquire, His Majesty's Remembrancer in Exchequer, relative to the tomb of King Robert Bruce, and the church of Dunfermline, communicated to the Society on 10 December 1821', *Archaeologia Scotia*, 2 (1822), 435-54, at 436; Penman, 'Robert Bruce's Bones', 14-5, 18-20.

evidence suggesting that the remains were Robert's.<sup>217</sup> The investigators concluded that the occupant of the tomb was Robert Bruce, corresponding to Bower's account that 'the king was buried..... in the middle of the choir with due honour.' His statement was an extended account of John Barbour's poem *The Brus*, mentioning that Robert was buried 'in the abbey choir',<sup>218</sup> which has been known as the first description of it. However, as Fraser insists, the scar on the chest was inconclusive evidence to confirm that Robert was the occupant of the grave. Royal heart burial was not uncommon throughout the Europe in the Middle Ages. Even though Robert I was the most well-known Scottish case, there were probably other royal heart burials including Alexander III's heart interment at Perth, which was described by Bower.<sup>219</sup>

Despite the suspicion of Robert's burial site, if he was buried there, that is, before the supposed high altar of the fourteenth-century church, he would have strongly exploited Dunfermline Abbey as a royal mausoleum to promote his authority and legitimacy as a successor of the Canmore kings. In other words, the place before the high altar was the most honourable site so the person most significant to the church was likely to have been buried there. For Dunfermline Abbey, it was certain that David I was ranked as the third most important figure as a patron and a saint, following St Margaret and Malcolm III. The interment of Robert I before the high altar could, therefore, indicate that he might have attempted to overtake David I by taking the most honourable site for himself. However, this assumption concerning the burial site of Robert I is hardly acceptable. Bower, who might have been a regular visitor to Dunfermline from Inchcolm to consult the library, also

---

<sup>217</sup> Jardine, 'Extracts from the report', 442.

<sup>218</sup> *Chron. Bower*, vii, 45; Duncan ed., *The Bruce - John Barbour*, 756.

<sup>219</sup> Fraser, 'The Tomb of the Hero King', 172; Simpson, 'The Heart of King Robert I', 173-9; Hallam, 'Royal burial and the cult of kingship in France and England, 1060-1330', 363-6; Estella Weiss-Krejci, 'Heart burial in medieval and early post-medieval Central Europe' in Katharina Rebay, Marie Louise Stig Sorensen and Jesscia Hughes eds., *Body Parts and Bodies Whole* (Oxford, 2010), 119-34; *Chron. Bower*, v, 420-1. However, Simpson suggests that Bower might have misinterpreted the heart burial of James I (d.1437) at Scone as that of Alexander III at Perth (Simpson, 'The Heart of King Robert I', 183-4, n. 23).

described how ‘in 1327 on 26 October Lady Elizabeth, the queen and mother of King David, died and was buried in the choir at Dunfermline next to her husband King Robert.’<sup>220</sup> This description might be read to mean that Robert I and Queen Elizabeth were buried as a couple. If this interpretation can be accepted, the claim that the single tomb before the high altar was the burial site of Robert seems to be wrong. In addition, focusing on the phrase of ‘buried in the choir’, Bower’s statement becomes less convincing as well, because the queen died prior to Robert so that it would have been unusual for Queen Elizabeth to be buried on her own before the high altar in the choir, where would have been allotted to only important figures to the abbey. In other aspects, regardless of who was buried in the choir, effigial tombs which required aisle-ambulatory space would not have been allowed in front of the high altar in order to admit liturgical activities, just as the tomb of Bishop William Sinclair at Dunkeld (1309-37) was to be relocated to the north-west of the choir from before the high altar.<sup>221</sup>

Queen Elizabeth and Robert I might have been more logically interred on the north side of the choir, where at least six flat slabs and four stone coffins were discovered in 1766 and 1807. According to the *Statistical Account* (1791-9), on the north of the choir ‘six flat stones, each nine feet in length’ were discovered.<sup>222</sup> Since the north of the choir was placed at the right hand side of God as viewed from the high altar,<sup>223</sup> the area was also an honourable place, although it was less than that of the spot before the high altar. With regard to the site of Queen Elizabeth’s tomb, it should also be noted that the remains of a female, considered to be that of Queen Elizabeth at that time, were discovered when a monument which was erected for the earl of Elgin (d.1771) ‘in the immediate vicinity of the tomb of King Robert Bruce’,

---

<sup>220</sup> *Chron. Bower*, vii, 35.

<sup>221</sup> R. Oram, ‘Bishops’ Tombs in Medieval Scotland’ in Penman ed., *Monuments and Monumentality across Medieval and Early Modern Europe*, 171-98, at 185.

<sup>222</sup> J. Sinclair ed., *The Statistical Account of Scotland*, 1791-99 (Edinburgh, 1794), xiii, 455; Fraser, ‘The Tomb of the Hero King’ 161-3; Penman, ‘Robert Bruce’s Bones’, 11.

<sup>223</sup> Fawcett, ‘Dunfermline Abbey Church’, 51.

that is, on the north-east of the choir according to the Plan drawn by Sir Henry Jardine (1766-1851), King's Remembrancer in Exchequer.<sup>224</sup>

If it can be accepted that Robert I and his Queen Elizabeth were buried as a couple on the north of the choir, just as Alexander III and his queen Margaret were probably buried as a pair on the southern side near the presbytery, this style may have been influenced by 18 Carolingian and Capetian tombs relocated at the command of Louis IX in the 1260s and rearranged by Philip IV in 1306-7.<sup>225</sup> However, a further question is raised: who is the occupant of the grave in front of the high altar at the fourteenth-century church? Since the remains of Malcolm III, who was also considered a saint, seem to have been reburied near to the 1250/1 shrine in the feretory chapel of St Margaret, the most reliable candidate to be buried before the high altar was David I, who was venerated at Dunfermline as a saint until the Reformation.<sup>226</sup> If so, the three shrines of St Margaret, Malcolm III and David I were treated with the greatest respect by interring their remains in honourable places such as the feretory chapel and the area in front of the high altar. That arrangement corresponded to the symbolic meaning of the veneration of the Holy Trinity. In terms of the dedication of the Holy Trinity, other evidence can be suggested as follows. Along with three tomb sites for St Margaret, the feretory chapel was framed on three-side walls with glass. St Margaret's miracle stories also show characteristics relating to the number 'three', as discussed above. In addition, there were three towers, two of which were raised over the aisles at the west end of the nave, the last of which was erected at the junction of choir, transepts and nave.<sup>227</sup> However, since there are three towers at Arbroath, Kilwinning, Holyrood Abbeys, and planned at Paisley Abbey, and the cathedrals at Glasgow and Aberdeen with no dedication to

---

<sup>224</sup> Jardine, 'Extracts from the Report', 448 and plate XI; Penman, 'Robert Bruce's Bones', 12.

<sup>225</sup> Brown, 'Burying and unburying the Kings of France', 246-9; Erlande-Brandenburg, *Le Roi Est Mort*, Planches, 26, 27; Hallam, 'Royal burial and the cult of kingship in France and England, 1060-1330', 374.

<sup>226</sup> St David's feast day is May 24, the date of his death (*Butler's Lives of the Saints*, eds. Herbert Thurston and Donald Attwater, 383-4).

<sup>227</sup> Fawcett, 'Dunfermline Abbey Church', 33-4.

Holy Trinity, it is hardly enough to say that three towers was a requirement for dedication to the Holy Trinity. But it could be said that they contributed to the Trinity dedication at churches such as Dunfermline Abbey and Elgin Cathedral.<sup>228</sup>

As discussed above, Robert I and his queen Elizabeth were probably buried as a pair on the north of the choir. Given the status of Robert I as a king who led the Scots to victory in the war of independence and raised national confidence, he deserved to be treated with respect by being buried close to the high altar. Therefore, the tombs of Robert I and his queen are likely to have been among the six flat slabs found on the north of the choir, positioned within the area nearest the high altar. The tombs in the north of the choir at Dunfermline had something in common: the length of all the six flat stones was nine feet.<sup>229</sup> In other words, these graves appear to have been set out at the same period of time, probably in the later thirteenth and the fourteenth centuries, that is, in the course of the refurbishment of the east part. In the same context, the black fossiliferous Frosterley marble from County Durham in 1315 which is likely to have been purchased at Robert I's command to make a new funeral effigy of William I at Arbroath Abbey<sup>230</sup> may give a clue to speculate that more marble from County Durham could have been bought to rearrange the graves on the north of the choir at Dunfermline. Furthermore, it can be cautiously speculated that the remains of Edgar and Alexander I were also translated from the nave to graves marked by two out of the six flat slabs in the north of the choir with the intention of enhancing national consciousness and emphasising Robert I's association with the Canmore kings, or in the course of Alexander III's rearrangement of the royal tombs following the style of St-Denis.

---

<sup>228</sup> Fawcett, *Scottish Medieval Churches*, 76.

<sup>229</sup> *The Statistical Account of Scotland*, 1791-99, ed. Sinclair, xiii, 455.

<sup>230</sup> Gimson, 'Lion Hunt: a royal tomb-effigy at Arbroath Abbey', 901-16; *RRS*, v, 360.

Plan 5. The fourteenth century church

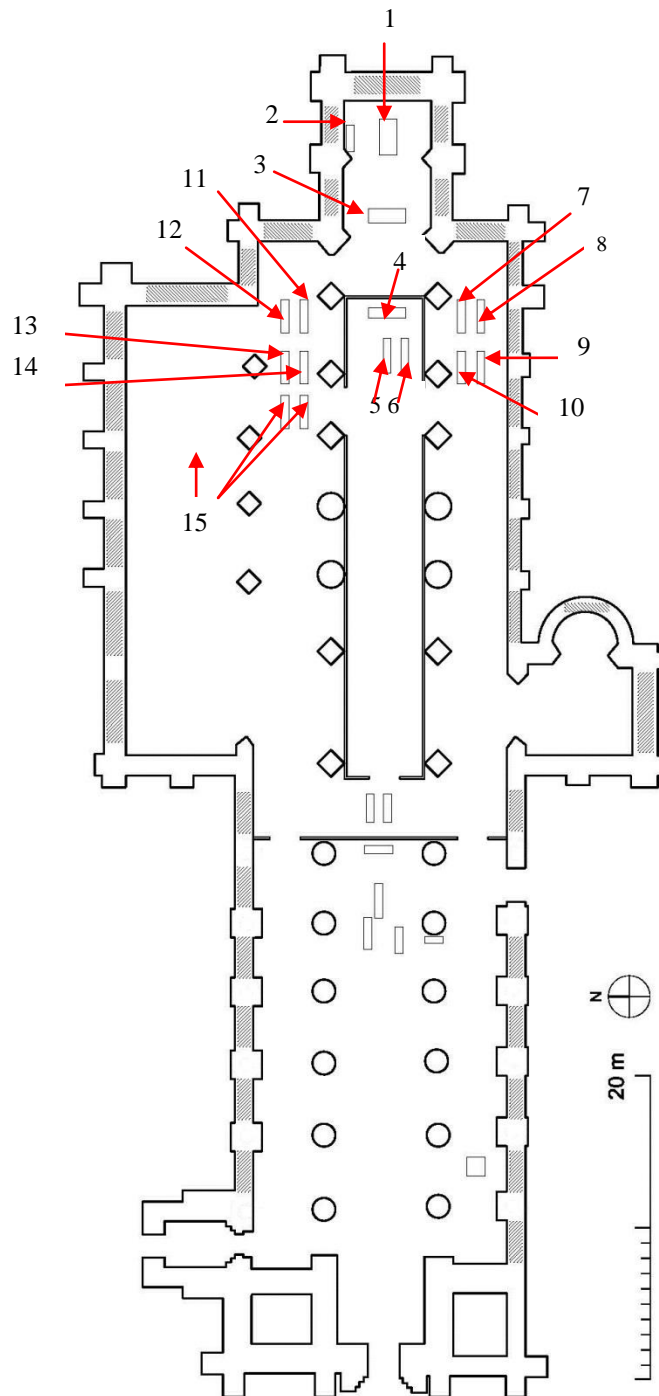

1. St Margaret's 1250/1 shrine; 2. Malcolm III's tomb; 3. relic altar; 4. high altar; 5. David's tomb; 6. Malcolm IV's tomb; 7. Alexander III's tomb; 8. Queen Margaret's tomb; 9 and 10: tombs of Princes David and Alexander; 11. Robert I's tomb; 12. Queen Elizabeth's tomb; 13. Edgar's tomb; 14. Alexander I's tomb; 15. Tombs of Thomas Randolph, Sir Andrew Moray, Christina Bruce, Matilda Bruce, Queen Euphemia, Queen Annabella and Robert duke of Albany



Robert's long-term illness might have encouraged him to arrange his own lavish tomb at Dunfermline. The *Exchequer Rolls* of 1329 specified payments for the purchase of an Italian marble tomb from Paris for Robert I's tomb, Baltic timber for a canopy over it, and labour charges regarding work on the tomb.<sup>231</sup> Robert I's tomb would have followed the style of French monarchs' tombs having been rearranged in the late thirteenth and fourteenth century, showing 'a tradition of white marble effigies, recumbent upon a contrasting black marble slab set upon a sculptured tomb-chest.'<sup>232</sup> Robert I's lavish tomb was supposed to surpass his rivals' tombs, the effigy-less tomb of Edward I or the alabaster tomb of Edward II.<sup>233</sup> Apart from the interment of Robert's body at Dunfermline, at his request his heart was buried at Melrose. Just as Robert's heart was interred separately, Queen Elizabeth's entails were buried in the church of the Virgin at Cullen where she had died, and her body was probably buried on the north of the choir at Dunfermline in 1327. In the same year, Robert founded the chaplainry at Cullen to pray for the soul of the queen and granted a yearly payment. The separate burials of royal corpses would have encouraged the proliferation of royal relics and the expansion of Masses for the crown throughout the realm.<sup>234</sup>

Alongside the status of Dunfermline Abbey as a royal mausoleum in this period, the abbey seemed to be chosen as a place for the birth of royal children. David II and his twin, John, were born there in 1324.<sup>235</sup> There is also the possibility that Robert Bruce's daughters were perhaps born at Dunfermline. Robert III's wife, Queen Annabella Drummond (c.1350-1401) was delivered of James Stewart at Dunfermline in probably 1394.<sup>236</sup> That her earlier children, David and Margaret named after two saints of Dunfermline suggests that the queen

---

<sup>231</sup> *ER*, i, 214, 213. Besides the purchase of the marble, in 1330 a payment to John of Lesydwyn for ironwork on the king's tomb and a gown (*Ibid*, 288); 1,500 sheets of gold-leaf for decorating the tomb (*Ibid*, 150, 221); 562 stones 5lbs. of wax requested for candles and torches during the funeral procession (*Ibid*, 151, 232).

<sup>232</sup> Fraser, 'The Tomb of the Hero King', 169-74.

<sup>233</sup> Penman, 'A Programme for Royal Tombs in Scotland? A Review of the Evidence, c.1093-c.1542', 244.

<sup>234</sup> *ER*, i, xciv, cxxiv-cxxv, 61, 91, 170, 271, 310, 355, 408, 469, 477, 549; Penman, "'Sacred food for the soul?'"

<sup>235</sup> *Chron. Fordun*, i, 350-1; *Chron. Bower*, vii, 35; Penman, *David II*, 19.

<sup>236</sup> Balfour-Melville, *James I*, 281-3.

might have come to Dunfermline for the delivery of them [1374/1378]. With regard to delivering a baby, St Margaret's 'sark' seems to have been considered a crucial relic. In 1450/1 Mary of Guelders, James II's wife, possessed St Margaret's 'sark' or shirt when she was delivered of a baby. In 1512 James IV's wife also used the sark during her delivery.<sup>237</sup> Charles I was also born at Dunfermline on 19 November 1600.<sup>238</sup> In addition, the *Auchinleck Chronicle* written in the mid-fifteenth century includes a tale of the remains of a body interred within an interior wall at Dunfermline, which might have been remains of a child or a relative of St Margaret.<sup>239</sup> Regardless of whether the statement is reliable or not, it seems to reflect that Dunfermline was believed to be a place for the royal birth.

The birth of royal children at Dunfermline has led to speculation about the possibility that royal children were also baptised there, given that in the Middle Ages baptism followed birth very closely due to the high levels of infant mortality. Even though there was no document indicating that they were baptized at Dunfermline, the later evidence that an infant prince called Robert was baptized at Dunfermline in 1602 suggests that royal babies were baptised there.<sup>240</sup> William I's itinerary showing his presence possibly at Stirling on 28 August 1198, at Scone on 5 September and at Stirling on 16 October,<sup>241</sup> suggests that William could have brought his son, the future Alexander II born at Haddington on 24 August 1198 to Dunfermline Abbey to have him baptised by Jocelin, bishop of Glasgow,<sup>242</sup> a successor of St Kentigern whose intercession might have been believed to help the birth of the new born

---

<sup>237</sup> For Mary of Guelders see *Miracula*, xxxviii-xxxix and *ER*, v, 447, 512. For James IV's wife see *TA*, iv, 334.

<sup>238</sup> Richard Cust, *Charles I* (Edinburgh, 2005), 2. He was baptised in the chapel royal at Holyrood palace on 23 December 1600 (Pauline Gregg, *King Charles I* (London, 1981), 4-5).

<sup>239</sup> Christine McGladdery, *James II* (Edinburgh, 1990), Appendix 2: The 'Auchinleck chronicle', f. 122v.

<sup>240</sup> Henderson, *The Annals Of Dunfermline and Vicinity*, 260. Charles, later Charles I (1600-49) and Elizabeth, later of Bohemia (1596-1662) were also born at Dunfermline (Aonghus Mackechnie, 'The Royal Palace of Dunfermline', 120).

<sup>241</sup> *RRS*, ii, nos. 402, 403, 404.

<sup>242</sup> *Chronicle of Melrose* (facsimile edition), eds. A.O. Anderson and others (London, 1936), s.a. 1198; *Chronica Roger de Hovedon*, ed. W. Stubbs (London, 1870), vol. iv, 54 in Archibald Campbell Lawrie, *Annals of the Reigns of Malcolm and William Kings of Scotland A.D. 1153-1214* (Glasgow, 1910), 313. Since Alexander II's birth was believed to be attributed to the intercession of St Kentigern, a patron saint of Glasgow, the bishop of Glasgow would have been favoured to baptize Alexander II.

baby.<sup>243</sup> Given that generally every parish church had a baptismal font in the nave, normally at its west end,<sup>244</sup> the baptismal font at Dunfermline would have been situated in the south-west area of the nave, probably nearby ‘St Margaret’s fountain’,<sup>245</sup> just as the baptismal fonts of Glasgow Cathedral and St Giles’ church in Edinburgh were placed in the south west side of the nave.<sup>246</sup> These circumstances suggest that Dunfermline was perhaps used as a royal nursery, and that the reconstruction and extension of the refectory and the guest houses under Robert I’s patronage was probably relevant to the project to make space for a royal nursery at Dunfermline - Robert and Queen Elizabeth de Burgh had four children.

As discussed above, at Dunfermline Abbey the choir and an ambulatory would have been allotted to the most significant burials. The lesser burials were restricted away from this area and in the Lady Chapel. In the chapel, the eastern part which was closer to the high altar would have been allotted for the burials of the family members of Robert Bruce. In this point, Westminster Abbey, which exercised an influence on Dunfermline in the mid-thirteenth century, shows a divergence from practice at Dunfermline Abbey. Unlike the location of the Scottish royal burials, English royal burials and those of non-members of the royal family at Westminster were clustered around St Edward the Confessor’s shrine.<sup>247</sup> The difference is largely attributable to the relative size of the church buildings. Westminster Abbey was spacious enough for several burial sites to be located just around St Edward’s shrine without

---

<sup>243</sup> Duncan, ‘St Kentigern at Glasgow Cathedral in the Twelfth Century’, 13; Norman F. Shead, ‘Jocelin, abbot of Melrose (1170-1174), and bishop of Glasgow (1175-1199)’, *Innes Review*, vol. 54 (1) (Spring 2003), 10.

<sup>244</sup> Fawcett, *Scottish Medieval Churches*, 299-304; J. Russell Walker, ‘Scottish baptismal fonts, with drawings’, *PSAS* 21 (1886-87), 346-448; McRoberts and Holmes, *Lost Interiors*, 115.

<sup>245</sup> *Miracula*, 79.

<sup>246</sup> See the plan of ‘Liturgical arrangements of Glasgow Cathedral in the fifteenth and sixteenth centuries’ from Radford, *Official Guide: Glasgow Cathedral*.; the plan showing ‘the pre-Reformation liturgical arrangements’ in Hay, ‘The late medieval development of the High Kirk of St Giles, Edinburgh’, 255. Baptismal fonts were kept safely and were not used for other purposes, observing the statutes of the Scottish church in the thirteenth century indicating that a baptismal font ‘may be decently covered over and reverently kept and not applied to other uses’, and should ‘be kept under safe keeping, locks and keys being provided, lest some overbold hand may reach forth to them to the commission of abominable and unspeakable acts (*Statutes of the Scottish Church*, ed. Patrick, 30, 58).’

<sup>247</sup> The tombs around St Edward’s shrine are as follows: Margaret and John de Valence (d.1276-77); Henry III (d.1272); Eleanor of Castile (d.1290); Aveline de Forz (d.1273), (c.1290-5); Edmund Crouchback, earl of Lancaster (d.1296); Edward I (d.1307); King Serbert (c.1307) (Duffy, *Royal Tombs of Medieval England*, 18-20; Binski, *Westminster Abbey and the Plantagenets*, 112).

using the interior of the choir. In contrast to Westminster, the abbey church at St-Denis was intended to be the burial place for anointed French monarchs alone by King Louis IX's instruction, even if his intention was subsequently ignored by his relatives and followers.<sup>248</sup> In this context, Dunfermline Abbey was more influenced by St-Denis. In addition, the church at Dunfermline was nowhere near as spacious as Westminster, so that there could be fewer tombs in its cramped interior.

Scotland, as discussed in Chapter Two, also followed the French monarchs' way of performing royal inauguration and burial at separate sites (as at Rheims and St-Denis) rather than the English kings' style of centring royal government and royal burial at Westminster. Apart from Alexander III's preference, as already noted, David's choir was probably designed to become a place for the royal coronation and it seems likely that the monks of Dunfermline made an effort to make their abbey the coronation church. However, the monks' effort did not come true because the first Scottish royal coronation was held at Scone on 24 November 1331, which was arranged and supervised by a parliament convened in September of that year.<sup>249</sup> Given these circumstances, it was obviously parliament which decided that the coronation would be held at Scone.

---

<sup>248</sup> *Ibid.*, 93; Brown, 'Burying and unburying the Kings of France', 246-7.

<sup>249</sup> Penman, 'Parliament Lost – Parliament Regained?', 77.

## **(6) Conclusion**

The veneration of St Margaret may have been originated with her son Edgar, who obtained the crown after the political turmoil caused by the conflict for the throne between his half- brother Duncan II, elder brother Edmund and his uncle Donald Bán. It seems likely that to promote the cult of a future St Margaret and to show his support of the church at Dunfermline he brought new monks to Dunfermline from Canterbury between 1100 and 1107. The veneration was probably developed in earnest by Alexander I, who was attempting to re-invigorate the Scottish church and align it with the mainstream of Continental religious practices by introducing the Augustinian order into Scotland. Given that Alexander I translated the remains of his father, Malcolm III from Tynemouth Priory to Dunfermline, and that he perhaps moved the body of his mother, Queen Margaret and laid it beside Malcolm III's, additionally, Alexander I probably completed the second phase of the early church in the course of translating the remains of his father and perhaps his mother. In this phase of the earlier church, the kings, Edgar and Alexander played a leading role in promoting the veneration of Margaret.

The patronage of David I and the abbacy of Abbot Geoffrey (1128-54) transformed the small church at Dunfermline into a large Romanesque abbey so that the twelfth-century church at Dunfermline could provide the monks with appropriate space in which they prayed and celebrated the Benedictine liturgy. With the development of liturgical space, a number of stations where pilgrims could visit and pray emerged, which could also have encouraged the laity to make a pilgrimage to Dunfermline. Above all, until St Margaret's remains were translated to David's church in 1180, the nave functioning as parish church focused on keeping the cult foci, and in particular, the east end of the nave including St Margaret's tomb was strongly emphasised. The year 1180 would be a turning point in the devotional history of the laity/pilgrims at Dunfermline. Alongside St Margaret's shrine translated to the choir in

1180, in 'David's church' David and Malcolm IV were buried, and David was regarded as a saint by the monks at Dunfermline, which meant that St David cult might also have been developed. Since 1180, the pivot of devotional practices of the laity at Dunfermline was moved to 'David's church' from the parish church.

Scottish royal association with Durham made it possible that a master mason and probably his followers were called to take part in construction at Dunfermline in the twelfth century. However, the liturgical practices of Canterbury would have influenced those of Dunfermline because since a number of monks and the first abbot at Dunfermline were from Canterbury, although pre-existing practices might also have been retained. In particular, an obituary of Christ Church at Canterbury in the early thirteenth century consisting of the name of Geoffrey, abbot of Dunfermline (1238-40), in the first column in a place of honour, and the name of Patrick, abbot of Dunfermline (1202-1217x1223) indicate a continuing association between Dunfermline and Canterbury until the 1240s.<sup>250</sup> This suggests that Canterbury exercised an influence on Dunfermline, and that the church at Dunfermline would have followed the mainstream of Benedictine tradition. Under these circumstances, therefore, the church seems still to have been emphasised primarily as a Benedictine monastic community rather than a royal religious centre accomplishing ideological and political purposes.

In the mid-thirteenth century, the launch of the campaign for Margaret's canonisation from 1245 under the leadership of Abbot Robert (1240-52), the canonisation in 1249 and the translation in 1250/1 might be viewed as a turning point in the history of Dunfermline from the point of view of liturgical space and liturgical practice. By being canonised, St Margaret was officially considered as a saint at the national level. As follow-up measures, the translation of the saint and the extension of the building and the rearrangement of the

---

<sup>250</sup> G.W.S. Barrow, 'A Scottish Collection at Canterbury', *SHR* 31 (1952), 27-8.

liturgical space led to the transformation of Dunfermline into a royal mausoleum in ideological and political terms. This transformation might have been encouraged by the trend to develop royal mausoleums at Westminster and a St-Denis around the same period. The Scottish Wars of Independence between 1296 and 1357 boosted a sense of Scottish national identity. To increase national self-confidence, promote royal authority and, in the case of Robert I to secure political legitimacy as a successor of the Canmore kings, there was no better place than Dunfermline Abbey. These circumstances might have accelerated the conversion of the abbey into a royal mausoleum. However, by the decision of a parliament of 1331 confirming Scone as the site for royal coronation, the dream of the monks at Dunfermline to make their abbey become a coronation church did not come true. Dunfermline was also perhaps used as a royal nursery, as a consequence of which the refectory and the guest house would have played an increasingly important role for hospitality.

In sum, while the identity of Dunfermline Abbey as a Benedictine church was more readily emphasised until the mid-thirteenth century, after the mid-thirteenth century the abbey was considered a royal mausoleum, focusing on a secular aspect as well as a spiritual one, and securing royal ideological and political aims. In addition, from the point of view of the liturgical space and the liturgy, the architecture of Dunfermline Abbey was designed to fulfil the dedication of three saints, St Margaret,<sup>251</sup> Malcolm III and David I. Along with three

---

<sup>251</sup> Some of royal family members and the nobles named their daughter after St Margaret, which would have reflected their devotion to St Margaret: Margaret of Huntingdon (1145–1201): a daughter of earl Henry son of King David, sister of King Malcolm IV and King William the Lion; Margaret (i), Countess of Kent (1193–1259): a legitimate daughter of King William I; Margaret (ii): an illegitimate daughter of King William I; Margaret (iii), or Marjorie (1209–1244): a younger legitimate daughter of King William I; Margaret of Huntingdon (c.1194–c.1228): a daughter of David earl of Huntingdon, wife of Alan the Great, lord of Galloway; Margaret, Queen of Norway (1261–1283): a daughter of King Alexander III and a wife of King Eric II of Norway; Margaret, Maid of Norway (1283–1290): a daughter of Margaret of Scotland, Queen of Norway; Margaret: a daughter of King Robert I, wife of William earl of Sutherland; Margaret Drummond (c.1340–c.1375): the second queen of David II; Margaret Stewart, Dauphine of France (1424–1445): a daughter of King James I, later dauphiness of France (*Chron. Bower*, ix, 495–6).

tomb sites for St Margaret, the veneration of three saints and the stained glass on the three sides of the feretory were presumably intended to correspond to the symbolism of the Holy Trinity.



## **Conclusion**

After Queen Margaret founded a priory church at Dunfermline in 1070 dedicated to the Holy Trinity, Scottish kings became the most significant patrons of that house. Through their devotion in turn to St Margaret at Dunfermline, the kings could display dynastic continuity and sacral kingship, and employ the spiritual and moral power of the royal saint to counter internal and external challenges. On a personal level dedication to St Margaret provided each king with the opportunity to pray for the salvation of the souls of their predecessors, successors and themselves. On a political level, the abbey also had significance because Dunfermline was a strategic base from where Malcolm III intended to expand his authority into the southern regions over the Strathclyde Britons to the south west and the Northumbrians to the south-east. His policy was inherited by his sons, King Edgar, Alexander I and David I. In addition, internal challenges which had initially been raised in 1093 by Donald Bán, Malcolm's brother, and Duncan II, the son of Malcolm's first marriage, encouraged the development of the veneration of St Margaret at Dunfermline during the reigns of these three successive kings. Thus, their favour to Dunfermline derived from ideological and political purposes as well as from their genuine devotion to their mother, St Margaret.

In particular, the reign of David I saw a large stride in the development of the royal cult and laying of the foundations for Dunfermline Abbey to be a royal mausoleum. As a result of David's effort, Dunfermline was raised to abbatial status in 1128. He launched the building scheme to extend the church, now known as the twelfth-century church or David's church, which was consecrated in 1150. David's favour to Dunfermline derived from his genuine piety and personal attempt to pray for the souls of his parents and brothers who were buried there, and the influence of his sister, Queen Matilda of England. On the political and ideological level his favour to Dunfermline was motivated by his strategic choice to employ

Dunfermline as a political centre upon the Forth, intending to appeal to the regional nobles of Fife, Ross, Mar, Atholl and Strathearn to accept his policies, such as feudal tenure and the new monastic and diocesan structures. Moreover, David's patronage to Dunfermline is understood as the response to early miracles of St Margaret, occurring before *c.*1150 - through the collecting of miracles the monks at Dunfermline Abbey presumably intended to display the holy power of St Margaret and, in consequence, to promote the cult of the saint and David's building scheme at Dunfermline - and the popularity of St Margaret's cult among the laity, who had little opportunity to access the shrine and receive miracles attributed to St Margaret until the abbey became the parish church in 1150.

Malcolm IV in turn venerated David, his immediate predecessor. Malcolm IV's favour to Dunfermline Abbey may have been motivated by his admiration for David rather than other reasons. Malcolm IV may have considered Dunfermline Abbey the shrine not only of St Margaret but also (St) David. By contrast, William I lost his interest in Dunfermline, since he founded Arbroath Abbey dedicated to St Thomas in 1178. Thereafter, the monks of Dunfermline could not turn the king's attention back to them, in spite of the translation of St Margaret's remains in 1180 which was presumably carried out by the monks of Dunfermline to boost and restore the reputation of the abbey and to meet the demand of both pilgrims and monks for more space, and which was presumably also a preliminary warning to a shift of William's favour to Arbroath Abbey, and St Margaret's alleged appearance during William's prayers at Dunfermline in 1199 to persuade him not to attack England. At the same time, the monks of Dunfermline also appealed to wider lay patronage *c.*1178-1220s to compensate for loss of King William's favour.

The mid-thirteenth century was a further turning point in the development of the cult of St Margaret. The internal and external challenges of the 1220s and the 1230s motivated Alexander II to boost royal authority and collective, regal identity. In addition, Henry III's

reconstruction scheme for Westminster Abbey and the cult of St Edward the Confessor from 1230 led Alexander to promote the dynastic cult at Dunfermline in the 1240s. As a result, Margaret was canonized in 1249. In 1250/1 the remains of St Margaret were translated into a new feretory chapel at the eastern end of the church. These events arguably represented a peak in interest in the dynastic cult at Dunfermline. Moreover, the subjects who oversaw the 1250/1 translation during the royal minority would have emphasized St Margaret's power in the shaping of national identity and royal authority.

Alexander III, who may have been interested in English saints, turned his attention to Dunfermline in the 1270s. The shift seems to have been influenced by his wife, Queen Margaret, daughter of Henry III, who was dedicated to St Margaret. In addition, the development of the English and French dynastic cult at Westminster and St-Denis in the second half of the thirteenth century led Alexander III to recognize the significance and value, both political and spiritual, of a royal saint and a royal mausoleum (sensibilities shared by his subjects who oversaw his burial at Dunfermline alongside his wife and sons in 1286).

John Balliol's reign was too short to employ the dynastic cult at Dunfermline in order to secure his legitimacy. Furthermore, the sudden death of the Maid of Norway, who had been heir to the throne, and her burial in Bergen denied Scots a further royal funeral at Dunfermline at the height of their succession crisis. In these circumstances, John's attempt to demonstrate his devotion to the royal saint in order to enhance his kingship and legitimacy would not have taken effect. After 1296, while English King Edward controlled (southern) Scotland, he also showed his devotion to the Scottish royal saint, focussing on Margaret's Anglo-Saxon lineage.

Robert I came to the throne through the sacrilegious murder of his Comyn rival and thus had suffered from a lack of legitimacy as king. Therefore, he needed to demonstrate his close association with the Canmore predecessors in order to enhance his legitimacy. In

addition, he was perhaps persuaded to emulate Edward, who established the royal mausoleum at Westminster, not merely for kings and queens but wider royal family members. These motivations led Robert to further develop Dunfermline as a royal church and royal mausoleum. In this context, the erection of the Lady Chapel and the reconstruction of the refectory building at Dunfermline were supported by Robert and his court. David II may have lost his interest in the cult of St Margaret after 1346 when the Scots were defeated at the battle of Neville's Cross and one of the saint's personal relics, a 'Black Rood', was lost. The contemporary implication would have been that St Margaret was inferior to St Cuthbert, a patron saint of Durham. Moreover, the failure of David II's prayers to St Margaret, who had been believed to have powers relating to childbirth, for the blessing of an heir, may have turned him away from Dunfermline. The early Stewart kings, Robert II and III opened a new dynasty. Therefore, they did need to neither emphasise the association with Canmore kings nor show devotion to the saint of the Canmore dynasty. However, naming some of Robert II's and Robert III's children after the Canmore kings and queen, and Queen Annabella Drummond's giving birth to James I at Dunfermline, allows us to speculate that Robert II and Robert III probably had a relationship with the Canmore dynastic cult in spiritual terms, although their political circumstances did not lead them to Dunfermline.

The Scottish kings' favour to Dunfermline and their devotion to the royal saint were determined by the kings' personal and political circumstances. In other words, from the perspective of the monks of Dunfermline, the status of St Margaret's cult was changeable, affected by currents of lay patronage, in particular, the favour of the king to the abbey. Especially at the crucial occasions such as at the moments for major building works launched in the 1120s, 1240/50s and 1320s, the monks of Dunfermline required royal favour. Therefore, the monks of Dunfermline tried to sustain royal favour to Dunfermline, adopting a strategic response whenever they lost the kings' favour. The 1180 translation, which was a

translation but without major building operation, was the typical case, and the miracle engaging William I in 1199 was also in part intended to remind William I of the existence of St Margaret. The monks considered David I and Malcolm III as saints, which may have been designed to encourage the piety of their successor kings. In addition, the moments when materials of Dunfermline's cartulary were presumably (re)written overlapped the periods when the abbey prospered and was rebuilt. This correspondence might have related to the aim of the monks of Dunfermline to draw or keep the crown's affection for the abbey.

The monks of Dunfermline also sought non-royal patronage to sustain the reputation of the cult. The evidence indicates that Dunfermline received a burst of patronage from non-royals during the reign of William I and the years of 1228, the 1230s, 1317, 1339 and the burials of Matilda Bruce and Christian Bruce in 1353 and 1357: the latter instances corresponded with a time when Dunfermline did not or could not receive direct royal patronage. Thus, the monks of Dunfermline sought non royal patronage to boost the status of the abbey or to survive in difficult times. In particular, key hinterland nobles - Fife, Meneith, Strathearn, Atholl - were likely to be crucial lay patrons. The appeal of the abbot and convent of Dunfermline even to English King Edward in order to have a market, and Edward's grant of privileges to that effect in 1304 and 1305, were also designed to sustain the abbey and its dedicative cult.

The purpose of the monks of Dunfermline to enhance the cult can be found in the strategic choice of the date of the saint's translation on 19 June 1250/1, just before Mid-Summer when it was a good season for the laity to travel, and which split the year in two alongside the date of St Margaret's death on 16 November. Moreover, St Margaret's miracles seem to have been exaggerated to show off St Margaret's holy power. For example, while Bower's description focused on the experience of a knight, John of Wemyss, who saw the saint in vision and heard her prediction of the victory at the battle of Largs in 1263, St

Margaret's miracle collection emphasised St Margret's performance in raising a fierce storm to protect the kingdom. These differences may be derived from the purpose of the monks of Dunfermline who wished St Margaret to be considered as a powerful saint and, in consequence, that her cult could be further developed.

The *Miracula* of St Margaret also demonstrates the monks' effort to draw the laity's attention. A very high proportion (89%) of St Margaret's miracles occurred in the abbey at Dunfermline, which presumably provided pilgrims with motivation to make a pilgrimage to Dunfermline, in the hope of a vision or miracle, and in return for an indulgence. None of St Margaret's miracle stories mention any of the saint's specific relic objects, such as the saint's shirt, gospel book or pieces of the Holy Cross, or parts of her own bodily relics, such as her head or hair. These omissions were probably designed to focus attention on the saint's shrine(s), dust and water/well within the abbey. In other words, they were intended to lead pilgrims to visit Dunfermline.

Concerning Dunfermline's relationship with Canterbury, Dunfermline was probably influenced by that great Benedictine house, mostly before Becket's martyrdom in 1170, and that Dunfermline would have followed the mainstream of Benedictine tradition until the mid-thirteenth century. Under these circumstances, Dunfermline was throughout emphasised as a Benedictine monastery community rather than a royal religious centre accomplishing an ideological and political purpose. However, the mid-thirteenth century would have been a turning point. St Margaret's canonization in 1249, the translation in 1250/1, along with the extension of the building and the rearrangement of the liturgical space, may have led Dunfermline Abbey to transform into far more so a royal church and mausoleum. The shift may have been encouraged by the development of royal mausoleums at Westminster and St-Denis from the mid-thirteenth century. Moreover, Dunfermline Abbey was perhaps used as a royal nursery, as a consequence of which, the refectory and the guest house would have

played an increasingly important role for hospitality. In other words, from the mid-thirteenth century Dunfermline Abbey which had been already considered as a royal mausoleum since the reigns of David and Malcolm IV focused on a more secular aspect as well as a spiritual one, thus secured royal ideological and political aims. Dunfermline Abbey was also designed to venerate three royal saints, St Margaret, Malcolm III and David I. Along with three tomb sites for St Margaret, the veneration of three saints and the stained glass on the three sides in the new feretory chapel, seem to have been intended to correspond with the symbolism of the Holy Trinity.

In addition, while two events in 1249 and 1250/1 were the most significant in the history of St Margaret's cult, the year 1180 marks a turning point in the alternation of devotional space. Until St Margaret's remains were translated to David's church in 1180, the nave functioning as parish church focused on keeping the cult foci, and in particular, the east end of the nave including St Margaret's tomb was strongly emphasised. Alongside the translation of St Margaret's shrine to David's choir in 1180, Malcolm III and David, both of whom were regarded as saints by the monks of Dunfermline, were buried in David's church. Thus, since 1180, the pivot of devotional practices of the laity at Dunfermline was moved to 'David's church' from the parish church.

The popularity of St Margaret's cult was beyond the royal family, and the cult had gained some level of popularity beyond Fife and Scotland. As St Margaret's *Miracula* demonstrate, when monks and a prior of Dunfermline, and priests are excluded from the list of miracle recipients, the cult turns out to be one spreading throughout Scotland and even down to England. St Margaret's miracles encouraged the laity to visit the abbey, which enhanced the possibility of miracles happening at the abbey, and *vice versa*. The increasing number of pilgrims visiting Dunfermline required more cult foci, including multiple tomb stations and side altars - more monks and private masses also produced more side altars. The

increase in number of monks and pilgrims needed more space, which led to the rebuilding and the extension of the church, and *vice versa*. Royal patronage may also have responded to genuine popularity of St Margaret's cult with wider populace, especially women, and *vice versa*. The miracles concerning King William in 1199, the battle of Largs in 1263, and St Margaret's prophesy of Scot's retaking of Edinburgh castle during Wars of Independence could place the cult of St Margaret at the nationwide level.

However, the monks of Dunfermline should make significant efforts at key moments to keep or not to lose the status of the cult of St Margaret, and it did not really develop any further beyond its 1250 peak as a 'national' church, apart from the Bruce dynastic tombs/Lady Chapel - Margaret did not become the leading national saint, or even a widely popular one, unlike Ninian/Duthac - nor did the abbey grow beyond c.1357. Burials stopped in the late fourteenth century with the exception of interments of Queen Euphemia Ross in 1387, Queen Annabella Drummond in 1401 and Albany in 1420. Nor did it gain status as a coronation church.

However, from the reign of James IV (1488–1513) Dunfermline was invested in once more by the crown. In the sixteenth century, there are some building operations at Dunfermline palace. For example, the reconstruction programme of major palaces during the reigns of James IV and James V (1513-1542) led to the extension at Dunfermline palace. James IV also paid for a new St Margaret head reliquary at Dunfermline.<sup>1</sup> In the 1590s, Queen Anne, wife of James VI, involved the construction of the Queen's Houses at Dunfermline palace. Moreover, she gave birth her children at Dunfermline.<sup>2</sup> The revival of Dunfermline in the sixteenth century needs scholar's future attention.

---

<sup>1</sup> *TA*, iv, 40.

<sup>2</sup> Aonghus Mackechnie, 'The Royal Palace of Dunfermline', 112-27.



## Bibliography

### Primary Sources:

#### Manuscript

British Library: BL, Add. MS 8835, fols 121r, 122v

National Library of Scotland: NLS. Adv. MS. 34. 1. 3A

#### Printed

*A Scottish chronicle known as the Chronicle of Holyrood*, Anderson M. O. (ed.) (Edinburgh, 1938)

*Accounts and Papers relating to Corporate offices and charitable Funds*, vol. 45 (1834)

*Accounts of the Lord High Treasurer of Scotland IV*, T. Dickson and J. Balfour Paul (eds.), 12vols. (Edinburgh 1877-1916)

*Acts of the Parliament of Scotland*, T. Thomson and C. Innes (eds.), 2 vols. (Edinburgh, 1844)

Ailred of Rievaulx, *Genealogia Regum Anglorum*, in *Patrologia Latina*, J.P. Migne (ed.), vols. 221 (Paris, 1844-64)

*Antiquities of Scotland*, Francis Grose, vol. ii (London, 1791)

Bower, Walter, *Scotichronicon*, D.E.R. Watt, *et al* (eds.), 9 vols. (Aberdeen, 1987-1999)

*Calendar of Documents relating to Scotland*, J. Bain (ed.), 5 vols. (Edinburgh, 1881-88)

*Calendar of Entries in the Papal Registers Relating to Great Britain and Ireland: Papal Letters*, W.H. Bliss (ed.), 16 vols. (London and Dublin, 1893)

*Calendar of Patent rolls, 1266-1272* (London, 1891-)

*Calendar of the Liberate Rolls*, vols. 6 (London, 1916-64), vol. 2

*Chronica Magistri Rogeri de Houedene*, W. Stubbs (ed.), 4 vols. (London, 1868-71)

*Chronicle of Melrose* (facsimile edition), A.O. Anderson and others (eds.), (London, 1936)

- Chronicles of the Reigns of Stephen, Henry II and Richard I*, R. Howlett (ed.), 4 vols. (Rolls Series, 1884-9)
- Documents illustrative of the History of Scotland 1286-1306*, J. Stevenson (ed.), (Edinburgh, 1870)
- Early Scottish Charters prior to 1153*, A. C. Lawrie (ed.), (Glasgow, 1905)
- Early Sources of Scottish History: 500-1286*, A.O. Anderson (ed.), 2 vols. (London, 1922)
- Flores Historiarum*, H. R. Luard (ed.), 3 vols. (Rolls Series, 1890)
- Giraldi Cambrensis opera*, J. S. Brewer, J. F. Dymock and G. F. Warner (eds.), 8 vols. (Rolls Series, 1861-91)
- Guillelmi Duranti: Rationale divinatorum officiorum*, A. Davril and T. M. Thibodeau (ed.), 2 vols. (Turnhout, 1995-8)
- Historical works of Gervase of Canterbury*, W. Stubbs (ed.), (Rolls Series, 1879-80)
- Islandske Annaler indtil 1578*, G. Storm (ed.), (Oslo [Christiania], 1888)
- Johannis de Fordun, Chronica Gentis Scotorum*, W.F. Skene (ed.), (Edinburgh, 1871)
- John of Fordun's Chronicle of the Scottish nation*, W. F. Skene (ed.), (Edinburgh, 1872)
- Liber Pluscardensis*, F. J. H. Skene (ed.), 2 vols. (Edinburgh, 1877-80)
- Liber Vitae Ecclesiae Dunelmensis*, J. Stevenson (ed.), (London, 1841)
- Litterae Cantuariensis*, J.B. Sheppard (ed.), 3 vols. (Rolls Series, London, 1887-9)
- Materials for the History of Thomas Becket, archbishop of Canterbury*, J.C. Robertson (ed.), 7 vols. (Rolls Series, London, 1875-85)
- Memoriale Fratris Walteri de Conventria*, W. Stubbs (ed.), (London, 1873)
- Memorials of St Dunstan, Archbishop of Canterbury*, W. Stubbs (ed.), (Rolls Series 63, 1874)
- Memorials of the Abbey of St Mary of Fountains*, J. R. Walbran,(ed.), 3 vols. (Durham, 1863-1918)
- Monumenta Germaniae Historica (Scriptores)*, Paul Scheffer-Boichorst (ed.), (Hanover, 1874)

*Monumenta Germaniae Historica, Scriptores Rerum Merovingicarum*, W. Amdt et al (eds.), vol. 1 (Hanover, 1884)

*Patrologiae cursus completus, series latina*, J.P. Migne, (ed.), 217 vols. (Paris, 1844-64)

*Regesta Regum Scottorum*, vol. 1, G.W.S. Barrow (ed.), (Edinburgh, 1960)

*Regesta Regum Scottorum*, vol. 2, G.W.S. Barrow (ed.), (Edinburgh, 1971)

*Regesta Regum Scottorum*, vol. 4, Cynthia J. Neville and Grant G. Simpson (eds.), (Edinburgh, 2012)

*Regesta Regum Scottorum*, vol. 5, A.A.M. Duncan (ed.), (Edinburgh, 1988)

*Regesta Regum Scottorum*, vol. 6, Bruce Webster (ed.), (Edinburgh, 1982)

*Regesta Regum Scottorum: Handlist of the Acts of Alexander II, 1214-1249*, James Scoular (ed.), (Edinburgh, 1959)

*Regesta Regum Scottorum: Handlist of the acts of Alexander III, the Guardians, John, 1249-1296*, Grant G. Simpson (ed.), (Edinburgh, 1960)

*Reginaldi monachi Dunelmensis libellus de admirandis beati Cuthberti virtutibus quae novellis patratae sunt temporibus*, J. Raine, (ed.), (London, 1835), vol. 1

*Registrum de Dunfermelyn liber cartarum Abbatie Benedictine S.S. Trinitatis et B. Margarete Regine de Dunfermelyn*, Bannatyne Club, (Edinburgh, 1842)

*Registrum Episcopatus Glasguensis*, Bannatyne and Maitland, 2 vols. (Edinburgh, 1843)

*Registrum magni sigilli Regum Scotorum: The register of the Great seal of Scotland, A.D. 1306-1424*, J. M. Thomson (ed.), 2 vols. (Edinburgh, 1882-1912)

*Rites of Durham: Being A Description Or Brief Declaration of All the Ancient Monuments, Rites and Customs belonging or being within the monastical church of Durham before the suppression. Written, 1593*, J.T. Fowler (ed.), (Durham, 1903)

*Scottish Annals from English Chroniclers AD 500-1286*, Alan O. Anderson (ed.), (London, 1908)

*Select Historical Document of the Middle Ages*, Ernest F. Henderson (trans. and ed.), (London, 1903)

- Sir Thomas Gray, Scalacronica 1272-1363*, A. King (ed.), (Woodbridge, 2005)
- Statutes of the Scottish Church 1225- 1559*, David Patrick (ed.), (Edinburgh, 1907)
- Symeonis Monachi Poera Omnia*, T. Arnold (ed.), 2 vols. (Rolls Series 75, 1882, 1885)
- The Ancient Kalendars and Inventories of the Treasury of his Majesty's Exchequer*, F. Palgrave (ed.), 3 vols. (London, 1836)
- The Bruce - John Barbour*, A.A.M. Duncan (ed.), (Edinburgh, 1997)
- The Burgh Records of Dunfermline*, Erskine Beveridge (ed.), (Edinburgh, 1917)
- The Charters of David I*, G.W.S. Barrow (ed.), (Woodbridge, 1999)
- The Chronicle of Melrose Abbey: A stratigraphic edition. Vol 1, Introduction and facsimile edition*, Broun D. and Harrison J. (eds.), (Woodbridge, 2007)
- The Exchequer Rolls of Scotland*, J. Stuart *et al* (eds.), 23 vols. (Edinburgh, 1878-1908)
- The Letters of Lanfranc Archbishop of Canterbury*, H. Clover and M. Gibson (ed.), (Oxford, 1979)
- The Lives of the Primitive Fathers, Martyrs, and other Principal Saints: Compiled from Original Monuments and Other Authenic Records*, Alan Butler (Edinburgh, 1799), vol. vi
- The miracles of St Æ bba of Coldingham and St Margaret of Scotland*, Robert Bartlett (ed.), (Oxford, 2003)
- The Monastic Constitutions of Lanfranc*, David Knowles and Christopher N. L. Brooke (eds.), (Oxford, 2002)
- The Original Chronicle of Andrew of Wyntoun*, F.J. Amours (ed.), 6 vols. (Edinburgh, 1914)
- The Orygynale Cronykil of Scotland*, D. Laing (ed.), 3 vols. (Edinburgh, 1872-79)
- The Statistical Account of Scotland*, J. Sinclair (ed.), 21 vols. (Edinburgh, 1791-99)
- Thesaurus Novus Anecdotorum*, E. Martène and U. Durand (eds.), 5 vols. (Paris, 1757)
- Thomas of Monmouth, *The Life and Miracles of St William of Norwich*, A. Jessopp and M. R. James (ed.), (Cambridge, 1896)

Turgot, *Life of St. Margaret, Queen of Scotland*, William Forbes-Leith (ed.), (Edinburgh, 1884)

*Vetera Monumenta Hibernorum et Scotorum Historiam Illustrantia*, A. Theiner (ed.), (Rome, 1864)

*Vita S Margaretae Scotorum Reginae in Symeonis Dunelmensis Opera et Collectanea*, G.H. Hinde (ed.), (Durham, 1867)

William of Malmesbury, *Gesta Regum Anglorum: The History of the English Kings*, R. A. B. Mynors; R. M. Thomson; and M. Winterbottom (eds.), 2 vols. (Oxford, 1998-9)

### **Referecne works:**

Brown, R. Allen; Colvin, H. M.; and Taylor, A.J., *The History of the King's Works*, vol. 1 (London, 1963)

Cheney, C. R., *Handbook of Dates for Students of English History* (London, 1978)

Dowden, John, *The Bishops of Scotland*, Thomson, J. M. (ed.), (Glasgow, 1912)

Knowles, David, *The Monastic Order in England: A History of its Development from the Times of St Dunstan to the Fourth Lateran Council 940-1216*, 2<sup>nd</sup> ed. (Cambridge, 1963)

MacEwan, A. R., *A History of the Church in Scotland* (London, 1913)

Mackay, Ae. J. G., *A History of Fife and Kinross* (Edinburgh and London, 1896)

Mackinlay, James Murray, *Ancient Church Dedication in Scotland: Non-Scriptural Dedication* (Edinburgh, 1914)

McNeill, Peter G. B. and MacQueen, Hector L. (eds.), *Atlas of Scottish History to 1707* (Edinburgh, 1996)

Watson, W. J., *The History of the Celtic Place-Names of Scotland* (Edinburgh, 1926)

Watt, D. E. R. and Shead, N. F. (eds.), *The Heads of Religious Houses in Scotland from the 12th to the 16th Centuries* (Edinburgh, 2001)

Watt, D. E. R., *A Biographical Dictionary of Scottish Graduates to A.D. 1410* (Oxford, 1977)

### **Secondary Sources:**

## **Books**

- Aird, William M., *St Cuthbert and the Normans: The Church of Durham, 1071-1153* (Woodbridge, 1998)
- Alexander, J., Binski, P. (eds.), *The Age of Chivalry: Art in Plantagenet England, 1200-1400* (London, 1987)
- Andas, Margaret Syrstad; Ekroll, Oystein; and Haug, Andreas (eds.), *The Medieval Cathedral of Trondheim: Architectural and Ritual Constructions in their European Context* (Turnhout, 2007)
- Baker, Derek (ed.), *Medieval Women* (Oxford, 1978)
- Balfour-Melville, E.W.M., *James I, King of Scots 1406-1436* (London, 1936)
- Barlow, Frank, *Thomas Becket* (London, 2000)
- Barlow, Frank (ed.), *The Life of King Edward the Confessor* (London, 1962)
- Barnwell, P. S.; Cross, Claire; and Rycraft, Ann (eds.), *Mass and Parish in late Medieval England: The Use of York* (Reading, 2005)
- Barrell, A.D.M., *Medieval Scotland* (Cambridge, 2000)
- Barrow, G.W.S., *Kingship and Unity: Scotland 1000-1306* (Edinburgh, 2003)
- Barrow, G.W.S., *Robert Bruce and the Community of the Realm of Scotland*, 4<sup>th</sup> ed. (Edinburgh, 2005)
- Barrow, G.W.S., *Scotland and its Neighbours in the Middle Ages* (London, 1992)
- Barrow, G.W.S., *The Kingdom of the Scots* (Edinburgh, 2003)
- Barrow, Geoffrey (ed.), *The Declaration of Arbroath: History, Significance, Setting* (Edinburgh, 2003)
- Bartlett, Robert, *The hanged man: A story of miracle, memory and colonialism in the Middle ages* (Princeton, 2004)
- Bartlett, Robert, *Trial by Fire and Water: The Medieval Judicial Ordeal* (Oxford, 1986)
- Beam, Amanda, *The Balliol Dynasty 1210-1364* (Edinburgh, 2008)

- Binns, Alison, *Dedications of Monastic Houses in England and Wales 1066-1216* (Woodbridge, 1989)
- Binski, Paul, *Becket's Crown: Art and imagination in Gothic England 1170-1300* (New Haven and London, 2004)
- Binski, Paul, *Westminster Abbey and the Plantagenets: Kingship and the Representation of Power, 1200-1400* (New Haven; London, 1995)
- Birkett, Helen, *The Saints' Lives of Jocelin of Furness: Hagiography, Patronage and Ecclesiastical Politics* (York, 2010)
- Blick, Sarah and Tekippe, Rita (eds.), *Art and Architecture of Late Medieval Pilgrimage in Northern Europe and The British Isles Texts* (Leiden, 2004)
- Blick, Sarah (ed.), *Beyond Pilgrim Souvenirs And Secular Badges: Essays in Honour of Brian Spencer* (Oxford, 2007)
- Bloch, Marc, *The Royal Touch: Sacred Monarchy and Scrofula in England and France*, (trans.) J.E. Anderson (London, 1973)
- Boardman, S.; Davies, J.R.; and Williamson, E. (eds.), *Saints' Cults in the Celtic World* (Woodbridge, 2008)
- Boardman, S., Williamson, Eila (eds.), *The Cult of Saints and the Virgin Mary in Medieval Scotland* (Woodbridge, 2010)
- Boardman, Steve, *The Early Stewart Kings: Robert II and Robert III 1371-1406* (East Linton, 1996)
- Bradley, Ian, *The Celtic Way* (London, 1993)
- Britnell, R.H. and Pollard, A.J. (eds.), *The McFarlane legacy: studies in late medieval politics and society* (Stroud, 1995)
- Brooke, D., *Wild Men and Holy Places: St Ninian, Whithorn and the Medieval Realm of Galloway* (Edinburgh, 1994)
- Brotherstone, Terry and Ditchburn, David (eds.), *Freedom and authority : Scotland c.1050-c.1650 historical and historiographical essays presented to Grant G. Simpson* (East Linton, 2000)

- Brown, Dauvit, *Scottish Independence and the Idea of Britain from the Picts to Alexander III* (Edinburgh, 2007)
- Brown, E. A. R.; Daley, B. E.; and O'donnell, J. J. *et.al.* (eds.), *Traditio: Studies in Ancient and Medieval History, Thought, and Religion* (New York, 1995)
- Brown, Keith M. and Tanner, Roland J. (eds.), *Parliament and Politics in Scotland, 1235-1560* (Edinburgh, 2004)
- Brown, Michael, *James I* (East Linton, 2000)
- Brown, Michael and Tanner, Roland (eds.), *Scottish Kingship 1306-1542* (Edinburgh, 2008)
- Brown, Michael, *The Wars of Scotland, 1214-1371* (Edinburgh, 2004)
- Brown, Peter, *The Cult of the Saints: Its rise and function in Latin Christianity* (Chicago, 1982, 1987)
- Brown, R. Allan (ed.), *Anglo-Norman Studies* 9 (1987)
- Brown, R. Allen (ed.), *Anglo-Norman Studies*, VI (Woodbridge, 1984)
- Brown, R. Allen, Colvin, H. M. and Taylor, A. J. (eds.) *The History of the King's Works: The Middle Ages*, 2 vols. (London, 1963), I
- Burleigh, J.H.S., *A Church History of Scotland* (London, 1960)
- Burton, Janet, *Monastic and Religious Orders in Britain, 1000-1300* (Cambridge, 1994)
- Burton, Janet; Schofield, Philipp; and Weiler, Bjorn (eds.), *Thirteenth Century England*, XII (Woodbridge, 2009)
- Butler, L. A. S. and Morris, R. K. (eds.), *The Anglo-Saxon Church: Papers on History, Architecture and Archaeology in Honour of Dr H. M. Taylor* (London, 1986)
- Campbell, Robert, *The law and practice of citation and diligence: on the basic of the late Mr Darling's book* (Edinburgh, 1862)
- Cant, Ronald G., *The College of St Salvator* (Edinburgh and London, 1950)
- Chibnall, M. (ed.), *Anglo-Norman Studies*, xii (Woodbridge, 1990)
- Chibnall, M. (ed.), *Anglo-Norman Studies* 16 (Woodbridge, 1994)



- Coldstream, N. and Draper, P. (eds.), *Medieval Art and Architecture at Durham Cathedral* (London, 1980)
- Collinson, P.; Ramsay, N.; and Sparks, M. (eds.), *A History of Canterbury Cathedral* (Canterbury and Oxford, 2002),
- Colvin, H. M., *Architecture and the After-Life* (London, 1991)
- Cowan, Ian B. and Easson, D. E., *Medieval Religious Houses: Scotland* (London, 1976)
- Crawford, Barbara E. (ed.), *Church, Chronicle and Learning in Medieval and Early Renaissance Scotland: Essays Presented to Donald Watt on the Occasion of the Completion of the Publication of Bower's Scotichronicon* (Edinburgh, 1999)
- Crook, John, *The Architectural Setting of the Cult of Saints in the Early Christian West c. 300 - 1200* (Oxford, 2000)
- Cross, P. R. and Lloyd, S. D. (eds.), *Thirteenth Century England* (Woodbridge, 1986)
- Cross, P. R. and Lloyd, S. D. (eds.), *Thirteenth Century England III.*, (Woodbridge, 1991)
- Cross, P. R. and Lloyd, S. D. (eds.), *Thirteenth Century England, V* (Woodbridge, 1995)
- Cruden, Stewart, *Scottish Medieval Churches* (Edinburgh, 1986)
- Cust, Richard, *Charles I* (Edinburgh, 2005)
- Dendy, D. R., *The Use of Lights in Christian Worship*, Alcuin Club Collections, 41 (London, 1959)
- Dennison, E. P. and Stronach, Simon, *Historic Dunfermline* (Dunfermline, 2007)
- Dennison, L. (ed.), *The Legacy of M. R. James* (Donington, 2001)
- Doig, Allan, *Liturgy and Architecture From the Early Church to the Middle Ages* (Aldershot, 2008)
- Donaldson, Gordon, *Scotland: Church and Nation through Sixteenth Centuries* (London, 1960)
- Draper, Peter and Coldstream, Nicola (eds.), *Medieval Art and Architecture at Canterbury before 1220* (Leeds, 1982)

- Duffy, Mark, *Royal Tombs of Medieval England* (Stroud, 2003)
- Duggan, Anne (ed.), *Queens and Queenship in Medieval Europe* (Woodbridge, 1997)
- Dunbar, A. H., *Scottish Kings: a revised chronology of Scottish history, 1005-1625*
- Duncan, A.A.M., *Scotland: The Making of the Kingdom* (Edinburgh, 1975)
- Duncan, A.A.M., *The Kingship of the Scots 842-1292: Succession and Independence* (Edinburgh, 2002)
- Eales, Richard and Sharpe, Richard (eds.), *Canterbury and the Norman Conquest: Churches, Saints and Scholars 1066-1109* (London, 1995)
- Ebenezer, Henderson, *The Annals Of Dunfermline And Vicinity: From The Earliest Authentic Period To The Present Time, A.D. 1069-1878* (Glasgow, 1879)
- Eeles, Francis C., *King's College Aberdeen*, (Edinburgh and London, 1956)
- Ellis, Steven G. and Klusakova, Lud'a (eds.), *Imaging frontiers, contesting identities* (Pisa, 2007)
- Emmison, Frederick and Stephens, Roy (eds.), *Tribute to an Antiquary: Essays Presented to Marc Fitch* (London, 1976)
- Erickson, Carolly, *The Medieval Vision: Essays in History and Perception* (New York, 1976)
- Erlande-Brandenburg, Alain, *Le Roi Est Mort: etude sur les funérailles les sépultures et les tombeaux des rois de France jusqu'à la fin du XIII<sup>e</sup> siè* (Droz, Genève, 1975)
- Ewan, Elizabeth; Innes, Sue; Reynolds, Sian; and Pipes Rose (eds.), *The Biographical Dictionary of Scottish Women: From the earliest times to 2004* (Edinburgh, 2006)
- Fawcett, Richard, *Dunfermline Abbey & Palace* (Edinburgh, 2004)
- Fawcett, Richard (ed.), *Medieval Art and Architecture in the Diocese of Glasgow* (Leeds, 1998)
- Fawcett, Richard and Oram, Richard, *Melrose Abbey* (Stroud, 2004)
- Fawcett, Richard (ed.), *Royal Dunfermline* (Edinburgh, 2005)
- Fawcett, Richard, *Scottish Medieval Churches: Architecture and Furnishings* (Stroud, 2002)

- Fawcett, Richard, *The Architecture of the Scottish Medieval Church 1100-1560* (New Haven and London, 2011)
- Finlay, Richard J. (ed.), *Scottish History: The Power of The Past* (Edinburgh, 2002)
- Finucane, Ronald C., *Miracles and Pilgrims: popular beliefs in Medieval England* (London, 1995).
- Foreville, R., *Le Jubilé de saint Thomas Becket du XIIIe au XVe siècle (1220-1470): etude et documents* (Paris, 1958)
- Foster, Sally M. (ed.), *The St Andrews Sarcophagus: A Pictish Masterpiece and Its International Connections* (Dublin, 1998)
- Fulton, Rachel, *From Judgment to Passion: Devotion to Christ and the Virgin Mary, 800-1200* (New York, 2002)
- Gilbert, J. M., *Hunting and Hunting Reserves in Medieval Scotland* (Edinburgh, 1979)
- Gillingham, J., *Richard I* (Norfolk, 1999)
- Glendinning, Miles (ed.), *The Architecture of Scottish Government: From Kingship to Parliamentary Democracy* (Dundee, 2004)
- Glick, Thomas F.; Livesey, Steven; and Wallis, Faith (eds.), *Medieval Science, Technology, and Medicine: An Encyclopaedia* (New York, 2005)
- Goodich, Michael E., *Miracles and Wonders: The Development of the Concept of Miracles, 1150-1350* (Aldershot, 2007)
- Gransden, Antonia (ed.), *Bury St Edmunds: Medieval Art, Architecture, Archaeology and Economy* (Leeds, 1998)
- Grant, Lindy and Mortimer, Richard (eds.), *Westminster Abbey: The Cosmati pavements* (Aldershot, 2002)
- Green, Judith A., *Henry I: King of England and Duke of Normandy* (Cambridge, 2009)
- Green, M.A.E., *Lives of the princesses of England*, 6 vols. (London, 1849-55)
- Harvey, Barbara, *Westminster Abbey and its Estates in the Middle Ages* (Oxford, 1977)

- Hermann-Masquard, N., *Les reliques des saints: formation coutumière d'un droit* (Paris, 1975)
- Higgitt, John (ed.), *Medieval art and architecture in the diocese of St Andrews* (Leeds, 1994)
- Howell, M., *Eleanor of Provence* (Cambridge, 1998)
- Huneycutt, Lois L., *Matilda of Scotland: A Study in Medieval Queenship* (Woodbridge, 2003).
- Itinerary of Edward I*, List and Index Society no. 135 (London, 1977)
- James, Bruno Scott (trans.), *The Letters of St Bernard*, 2<sup>nd</sup> ed. (Stroud, 1998)
- Jamroziak, Emilia and Burton, Janet (eds.), *Religious and laity in Northern Europe 1000-1400: Interaction, Negotiation and Power* (Turnhout, 2007)
- Jancey, Meryl (ed.), *St Thomas Cantilupe, Bishop of Hereford: Essays in His Honour* (Hereford, 1982)
- Jordan, William Chester, *A Tale of Two Monasteries: Westminster and Saint-Denis in the Thirteenth Century* (Princeton, 2009)
- Koopmans, Rachel, *Wonderful to Relate: Miracle Stories and Miracle Collecting in High Medieval England* (Pennsylvania, 2011)
- Koss, Cynthia and Scott, Anne (eds.), *The Nature and Function of Water, Baths, Bathing and Hygiene from Antiquity through the Renaissance* (Leiden, 2009)
- Kroesen, Justine E.A. and Schmidt, Victor M. (eds.), *The Altar and its Environment 1150-1400* (Leiden, 2010)
- Le Goff, Jacques, *The Birth of Purgatory*, Arthur Goldhammer (trans.) (London, 1984)
- Lewis, John and Ewart, Gordon (eds.), *Jedburgh Abbey, the archaeology and architecture of a border abbey* (Edinburgh, 1995)
- Limia, Stephen and Valdez del Álamo, Elizabeth (eds.), *Decorations for the Holy Dead: Visual Embellishments on Tombs and Shrines of Saints* (Turnhout, 2003)
- Lowe, Christopher (ed.), *'Clothing for the Soul Divine': Burials at the Tombs of St Ninian*
- Lynch, M., *Scotland: A New History* (London, 1992)
- Macdougall, Norman, *James III: A Political Study* (Edinburgh, 1982)

- MacGibbon, David and Ross, Thomas, *The Ecclesiastical Architecture of Scotland from the Earliest Christian Times to the Seventeenth Century* (Edinburgh, 1896)
- Macquarrie, Alan, *The Saints of Scotland :Essay in Scottish Church History AD 450-1093* (Edinburgh, 1997)
- Malden, John (ed.), *The Monastery & Abbey of Paisley* (Renfrewshire, 2000)
- Marshall, R.K., *Scottish Queens 1034-1714* (East Linton, 2003)
- Mason, Emma, *Westminster Abbey and its People, c.1050-1216* (Woodbridge, 1996)
- McGladdery, Christine, *James II* (Edinburgh, 1990)
- McRoberts, David and Holmes, Stephen Mark, *Lost Interiors: The Furnishings of Scottish Churches in the Later Middle Ages* (Edinburgh, 2012)
- Meek, Donald E., *The Quest for Celtic Christianity* (Edinburgh, 2000).
- Mercer, A., *The History of Dunfermline, from the earliest records, down to the present time* (Dunfermline, 1828)
- Metcalf, W. M., *A History of Paisley 600-1908* (Paisley, 1909)
- Moir-Bryce, W., 'The Black Friars of Edinburgh', *Book of the Old Edinburgh Club*, iii (1910)
- Morris, Colin and Roberts, Peter (eds.), *Pilgrimage: The English Experience from Becket to Bunyan* (Cambridge, 2002)
- Morrison, Susan S., *Women Pilgrims in Late Medieval England: Private Piety as Public Performance* (New York, 2000)
- Mortimer, Richard (ed.), *Edward the Confessor: The Man and the Legend* (Woodbridge, 2009)
- Mousolf, A. J. M. and J. K., *Saint Companions for Each Day* (new revised edition, Mumbai, 2005)
- Nicholson, Ranald, *Scotland: the later Middle Ages* (Edinburgh, 1974)
- Nilson, Ben, *Cathedral Shrines of Medieval England* (Woodbridge, 2001)
- Numbers, Ronald L. and Amundsen, Darrel W., *Caring and Curing: Health and Medicine in the Western Religious Tradition* (New York, 1986)

- O'Connell, J., *Church Building and Furnishing: The Church's Way* (London, 1955)
- Ohler, Norbert, *The Medieval Traveller* (Woodbridge, 1998)
- Oram, Richard, *Alexander II, King of Scots 1214-1249* (Edinburgh, 2012)
- Oram, Richard, *David I: The King who made Scotland* (Stroud, 2004)
- Oram, Richard, *Domination and Lordship: Scotland 1070-1230* (Edinburgh, 2011)
- Oram, Richard (ed.), *The Reign of Alexander II, 1214-49* (Leiden, 2005)
- Orme, Nicholas and Webster, Margaret, *The English Hospital, 1070-1570* (New Haven and London, 1995)
- Ormrod, W. M. (ed.), *England in the Thirteenth Century* (Nottingham, 1985)
- Ormrod, W. M. (ed.), *Fourteenth Century England III* (Woodbridge, 2004)
- Osborne, K. B., *Reconciliation and Justification: the Sacrament and its Theology* (New York, 1991)
- Owen, D.D.R., *William the Lion: Kingship and culture, 1143-1214* (East Linton, 1997)
- Palliser, D. M. (ed.), *The Cambridge Urban History of Britain I: 600-1540* (Cambridge, 2000)
- Pearson, Mike Parker, *The Archaeology of Death and Burial* (Stroud, 1999)
- Penman, Michael, *David II, 1329-71* (Edinburgh, 2004)
- Penman, Michael (ed.), *Monuments and Monumentality in Later Medieval and Early Modern Europe* (Donington, 2013).
- Perkins, J., *Westminster Abbey: its worship and its ornaments*, vol. 2, (London, 1938)
- Pfaff, Richard W., *The Liturgy in Medieval England: A History* (Cambridge, 2009)
- Piroyandsky, Danna, *Martyrs in the Making: Political Martyrdom in Late Medieval England* (New York, 2008)
- Plöger, Karsten, *England and the Avignon Popes: The Practice of Diplomacy in Late Medieval Europe* (Legenda, 2005)

- Powicke, F. M., *The Thirteenth Century: 1216-1307*, 2<sup>nd</sup> ed. (Oxford, 1962)
- Prestwich, M., *Edward I* (London, 1988)
- Prestwich, Michael; Britnell, Richard; and Frame, Robin (eds.), *Thirteenth Century England VIII* (Woodbridge, 2001)
- Prestwich, Michael, *The Three Edwards: Wars and State in England, 1272-1377* (London, 1980)
- Radford, C. A. Raleigh, *Official Guide: Glasgow Cathedral* (Edinburgh, 1970)
- Raguin, Virginia C.; Brush, Kathryn; and Draper Peter (eds.), *Artistic Integration in Gothic Buildings* (Toronto, 1995)
- RCAHMS, *Inventory of Fife* (Edinburgh, 1933)
- Rebay, Katharina; Sorensen, Marie Louise Stig; and Hughes, Jessica (eds.), *Body Parts and Bodies Whole* (Oxford, 2010)
- Reid, N.H. (ed.), *Scotland in Reign of Alexander III, 1249-86* (Edinburgh, 1988)
- Reid, R. C. (ed.), *Wigtonshire Charters* (Edinburgh, 1960)
- Richards, Peter, *The Medieval Leper and His Northern Heirs* (Woodbridge, 2000)
- Rivard, Derek A., *Blessing the World: Ritual and Lay Piety in Medieval Religion* (Washington, 2009)
- Rollanson, D. W. and Prestwich, M. C. (eds.), *Battle of Neville's Cross, 1346* (Stamford, 1998)
- Rollason, David; Harvey, Margaret; and Prestwich, Michael (eds.), *Anglo-Norman Durham, 1093–1193* (Woodbridge, 1994)
- Rubin, Miri, *Charity and Community in Medieval Cambridge* (Cambridge, 2002)
- Rushforth, Rebecca, *St Margaret's Gospel-book: The favourite book of an eleventh century Queen of Scots* (Oxford, 2007)
- Sheingorn, Pamela, *The Easter Sepulchre in England* (Western Michigan, 1987)
- Sigal, Piere-Andre, *L'homme et le miracle dans France medievale, XIe-XIIe siecle* (Paris, 1985)

- Slocum, Kay Brainerd, *Liturgies in Honour of Thomas Becket* (Toronto, 2003)
- Smith, D., *Revisiting the Empty Tomb: The Early History of Easter* (Minneapolis, 2010)
- Southern, R. W., *Medieval Humanism and Other Studies* (Oxford, 1970)
- Spencer, Brian, *Pilgrimage Souvenirs and Secular Badges* (Woodbridge, 2010)
- Staunton, Michael, *The Lives of Thomas Becket* (Manchester, 2001)
- Steane, John, *The Archaeology of the Medieval English Monarchy* (London, 1998)
- Stones, E.L.G. and Simpson, Grant G., *Edward I and the Throne of Scotland 1290-1296: An Edition of the Record Sources for the Great Cause* (Glasgow, 1978), vol. 2
- Strickland, Matthew, *War and Chivalry : The Conduct and Perception of War in England and Normandy, 1066-1217* (Cambridge, 1996)
- Sumption, Jonathan, *Pilgrimage: An Image of Medieval Religion* (London, 1975)
- Swanson, R. N., *Late Medieval England: Passports to Paradise?* (Cambridge, 2007)
- Taylor, Simon and Márkus, Gilbert, *The Place-Names of Fife*, vol. I, *West Fife between Leven and Forth* (Donington, 2006)
- Thacker, Alan and Sharpe, Richard (eds.), *Local Saints and Local Churches in the Early Medieval West* (Oxford, 2002)
- Theissen, Gerd, *The Miracle Stories of the Early Christian Tradition*, John Riches (trans.) (Philadelphia, 1983)
- Thurston, Herbert and Attwater, Donald (eds.), *Butler's Lives of the Saints* (Texas, 1956)
- Trexler, Richard C. (ed.), *Persons in Groups: Social Behavior as Identity Formation in Medieval and Renaissance Europe* (Binghampton, 1985)
- Vallance, Aymer, *Greater English Church Screens: Being Great Roods, Screenwork and Rood-Lofts in Cathedral, Monastic and Collegiate Churches in England and Wales* (London, 1947)
- Van der Loos, H., *The Miracles of Jesus* (Leiden, 1965)
- Vauchez, André, *Sainthood in the later Middle Ages* (Cambridge, 2005)



- Walcott, M.E.C., 'The Bishops of Chichester from Stigand to Sherbourne', *Sussex Archaeological Collections*, vol. 28 (1878)
- Ward, Benedicta, *Miracles and the Medieval Mind: Theory, Record, and Event 1000-1215* (Pennsylvania, 1987)
- Watson, F., *Under the hammer: Edward I and Scotland* (East Linton, 1998)
- Watt, D.E.R., *Medieval Church Councils in Scotland* (Edinburgh, 2000)
- Webb, Diana, *Pilgrimage in Medieval England* (London, 2000)
- Webb, Geoffrey, *Architecture in Britain: the Middle Ages* (Baltimore, 1965)
- Willis, R., *The Architectural History of Canterbury Cathedral* (London, 1845)
- Wilson, Alan J., *St Margaret, Queen of Scotland* (Edinburgh, 2001)
- Wood, Diana (ed.) *Martyrs and Martyrologies* (Oxford, 1993)
- Woodman, Francis, *The Architectural History of Canterbury Cathedral* (London and Boston, 1981)
- Yarrow, Simon, *Saints and their Communities: Miracle Stories in Twelfth-Century England: Miracle Stories in Twelfth-Century England* (Oxford, 2006)
- Yeoman, Peter, *Pilgrimage in Medieval Scotland* (Edinburgh, 1998)

### Articles

- Aird, William M., '“Sweet Civility and Barbarous Rudeness’ a View from the Frontier, Abbot Ailred of Rievaulx and the Scots’ in *Imaging frontiers, contesting identities*, 59-75
- Ash, M., 'The Church in the reign of Alexander III' in *Scotland in Reign of Alexander III, 1249-86*, 31-53
- Baker, Derek, '“A Nursery of Saints’: St Margaret of Scotland Reconsidered’ in *Medieval Women*, 119-42
- Bannerman, J., 'The Scottish takeover of Pictland and the relics of Columba', *Innes Review*, 48 (1997), 27-44.

- Barrell, A. D.M., 'Scotland and The Papacy in the Reign of Alexander II' in *The Reign of Alexander II, 1214-49*, 157-77
- Barrow, G.W.S., 'A Scottish Collection at Canterbury', *SHR* 31 (1952), 16-28
- Barrow, G.W.S., 'David I of Scotland: The Balance of New and Old' in *Scotland and its Neighbours in the Middle Ages*, 45-66
- Barrow, G.W.S., 'From Queen Margaret to David I: Benedictines and Tironensians', *Innes Review*, vol. 6 (1960), 22-38
- Barrow, G.W.S., 'The earliest Stewarts and their lands' in *The Kingdom of the Scots*, 312-29
- Barrow, G.W.S., 'The Kings of Scotland and Durham' in *Anglo-Norman Durham, 1093-1193*, 311-24
- Bartlett, Robert, 'The Hagiography of Angevin England' in *Thirteenth Century England*, V, 37-52
- Barton, Allan B., 'The ornaments of the altar and the ministers in late medieval England' in *Mass and Parish in late Medieval England: The Use of York*, 27-40
- Beam, Amanda, 'John Balliol, the Bishops of Durham, and Balliol college, 1255-1260', *Northern History*, XLII: 2 (September, 2005), 239-56
- Biddle, Martin, 'Archaeology, architecture and the cult of the saints in Anglo-Saxon England' in *The Anglo-Saxon Church*, 1-31
- Binski, Paul, 'Reflection on La estoire de Seint Aedward le rei: hagiography and kingship in thirteenth-century England', *Journal of Medieval History* 16 (1990), 333-50
- Binski, Paul, 'Statues, Retables and ciboria: The English Gothic Altarpiece in Context, before 1350' in *The Altar and its Environment 1150-1400*, 31-46
- Birkett, Helen, 'Promoting Sanctity: The *Vita S. Waldevi*, Canonization and Cistercian Sainly Cults' in *The Saints' Lives of Jocelin of Furness: Hagiography, Patronage and Ecclesiastical Politics*, 201-26
- Birkett, Helen, 'The Struggle for Sanctity: St Waltheof of Melrose, Cistercian in-house cults and canonisation Procedure at the turn of the thirteenth century' in *The Cult of Saints and the Virgin Mary in Medieval Scotland*, 43-60

Blick, Sarah, 'Reconstructing the Shrine of St Thomas Becket, Canterbury Cathedral' in *Art and Architecture of Late Medieval Pilgrimage in Northern Europe and the British Isles Texts*, 405-42

Boardman, Steve, 'Dunfermline as a Royal Mausoleum' in *Royal Dunfermline*, 139-54

Boardman, S., 'Coronations, Kings and Guardians: Politics, Parliaments and General Councils, 1371-1406' in *Parliament and Politics in Scotland, 1235-1560*, 102-22

Boardman, S., 'Later Medieval Scotland and the Matters of Britain' in *Scottish History: The Power of The Past*, 47-72

Boardman, S., Robert II (1371-1390)' in *Scottish Kingship 1306-1542*, 72-108

Boertjes, 'Pilgrim Ampullae of York Minster and the Healing Oil from the Shrine of St William' in *Beyond Pilgrim Souvenirs And Secular Badges*, 48-63

Boyle, A., 'Notes on Scottish Saints', *Innes Review*, xxxii (1981), 59-82

Bozoky, Edina, 'The Sanctity and Canonization of Edward the Confessor' in *Edward the Confessor: The Man and the Legend*, 173-86

Brenk, Beat, 'The Sainte-Chapelle as a Capetian Political Program' in *Artistic Integration in Gothic Buildings*, 195-213

Bridgland, Nick, 'Dunfermline Abbey: Cloister and Precinct' in *Royal Dunfermline*, 89-100

Broun, Dauvid, 'A New Look at *Gesta Annalia* Attributed to John of Fordun' in *Church, Chronicle and Learning in Medieval and Early Renaissance Scotland: Essays Presented to Donald Watt on the Occasion of the Completion of the Publication of Bower's Scotichronicon*, 9-30

Brown, Elizabeth A. R., 'Burying and Unburying the Kings of France' in *Persons in Groups: Social Behavior as Identity Formation in Medieval and Renaissance Europe*, 241-66

Caldwell, David H., 'The Monymusk Reliquary: the Breccbennach of St Columba?', *PSAS*, 131 (2001), 267-82

Cambridge, Eric, 'Early Romanesque Architecture in North-East England: A Style and its Patrons' in *Anglo-Norman Durham, 1093-1193*, 141-60

Cameron, Neil, 'The Romanesque Sculpture of Dunfermline Abbey' in *Royal Dunfermline*, 65-78

Cameron, S., 'Sir James Douglas, Spain and the Holy Land' in *Freedom and authority: Scotland c.1050-c.1650. historical and historiographical essays presented to Grant G. Simpson*, 108-17

Carpenter, D. A., 'King Henry III and Saint Edward the Confessor: The Origins of the Cult', *English Historical Review* vol. CXXII, no. 498 (2007), 865-91

Carpenter, D. A., 'The Fall of Hubert de Burgh', *Journal of British Studies* 19 (1980), 1-17

Carpenter, D. A., 'Westminster Abbey and the Cosmati pavement in politics, 1258-1269' in *Westminster Abbey: The Cosmati pavements*, 37-48

Carpenter, D. A., 'Westminster Abbey in Politics, 1258-1269' in *Thirteenth Century England VIII*, 49-58

Chadd, David, 'The Ritual of Palm Sunday: Reading Nidaros' in *The Medieval Cathedral of Trondheim: Architectural and Ritual Constructions in their European Context*, 253-78

Clancy, Thomas Owen, 'Scottish Saints and National Identities in the Early Middle Ages' in *Local Saints and Local Churches in the Early Medieval West*, 397-421

Clancy, Thomas Owen, 'The Big Man, The Footsteps, and the Fissile Saint: Paradigms and Problems in Studies of Insular Saints' Cults' in *The Cult of Saints and the Virgin Mary in Medieval Scotland*, 1-20

Crook, John, 'Aspects of Relic Cults' in *The Architectural Setting of the Cult of Saints in the Early Christian West c. 300-1200*, 6-39

Crook, John, 'The Architectural Setting of the Cult of St Edmund at Bury 1095-1539' in *Bury St Edmunds: Medieval Art, Architecture, Archaeology and Economy*, 34-44

Crumplin, Sally, 'Cuthbert the Cross-Border Saint in the Twelfth Century' in *Saints' Cults in the Celtic World*, 119-29

Dalton, Paul, 'Scottish Influence on Durham 1066-1214' in *Anglo-Norman Durham, 1093-1193*, 339-52

Dennison, E. Patricia, 'Living in Medieval Dunfermline' in *Royal Dunfermline*, 1-26

Ditchburn, David, 'Saints and Silver: Scotland and Europe in the age of Alexander II' in *The Reign of Alexander II*, 179-210

Ditchburn, David, 'The 'McRoberts Thesis' and Patterns of Sanctity in Late Medieval Scotland' in *The Cult of Saints and the Virgin Mary in Medieval Scotland*, 177-94

Dobson, B., 'The monks of Canterbury in the later middle ages', in *A History of Canterbury Cathedral*, 69-153

Draper, Peter, 'Architecture and Liturgy' in *The Age of Chivalry: Art in Plantagenet England, 1200-1400*, 83-91

Draper, Peter 'The Nine Altars at Durham and Fountains' in *Medieval Art and Architecture at Durham Cathedral*, 74-86

Driscoll, Stephen T., 'Highlights of the Excavations at Glasgow Cathedral 1992-93' in *Medieval Art and Architecture in the Diocese of Glasgow*, 25-34

Duncan, A.A.M., 'St Kentigern at Glasgow Cathedral in the Twelfth Century' in *Medieval Art and Architecture in the Diocese of Glasgow*, 9-24

Duggan, A., 'The cult of St Thomas Becket in the thirteenth century' in *St Thomas Cantilupe, Bishop of Hereford*, 21-44

Eales, Richard, 'The political setting of the Becket translation of 1220' in *Martyrs and Martyrologies*, 127-39

Eeles, F. C., 'The inventory of the Chapel Royal at Stirling, 1505: a new translation with introduction and notes', *Transactions of the Scottish Ecclesiastical Society* 3 (1912), 310-25

Fawcett, Richard, 'Arbroath Abbey: A Note on its Architecture and Early Conservation History' in *The Declaration of Arbroath: History, Significance, Setting*, 50-85

Fawcett, Richard, 'Dunfermline Abbey Church' in *Royal Dunfermline*, 27-64

Fawcett, Richard, 'Paisley Abbey Church: The Medieval Architecture' in *The Monastery & Abbey of Paisley*, 37-49

Fernie, Eric, 'St Anselm's Crypt' in *Medieval Art and Architecture at Canterbury before 1220*, 27-38

Fernie, Eric, 'The architectural influence of Durham Cathedral' in *Anglo-Norman Durham, 1093-1193*, 269-79

Fernie, Eric, 'The Romanesque churches of Dunfermline Abbey' in *Medieval art and architecture in the diocese of St Andrews*, 25-37

Fernie, Eric, 'The Romanesque Church of Waltham Abbey', *Journal of the British Archaeological Association*, vol. 138 (1985), 48-78.

Finucane, Ronald C., 'Cantilupe as Thaumaturge: Pilgrims and Their 'Miracles' in *St Thomas Cantilupe, Bishop of Hereford: Essays in His Honour*, 137-44

Foster, Sally M., 'Discovery, Recovery, Context and Display' in *The St Andrews Sarcophagus: A Pictish Masterpiece and Its International Connections*, 36-62

Fraser, Iain, 'The Tomb of the Hero King: The Death and Burial of Robert I, and the Discoveries of 1818-19' in *Royal Dunfermline*, 155-176

Fraser, J.E., 'Northumbrian Whithorn and the Making of St Ninian', *IR*, 53 (2002), 40-59

Gilchrist, Roberta, 'Community and Self: Perceptions and Use of Space in Medieval Monasteries', *Scottish Archaeological Review*, vol. 6 (1989), 55-64.

Gimson, G. S., 'Lion Hunt: a royal tomb-effigy at Arbroath Abbey', *PSAS*, 125 (1995), 901-16

Goodich, Michael E., '*Vidi in Somnium*: The Uses of Dream and Vision in the Miracle' in *Miracles and Wonders*, 100-16.

Gullick, M., 'The English owned manuscript of the *Collectio Lanfranci* (s.xi/xii)' in *The Legacy of M. R. James*, 99-117

Hall, M.A., 'Of holy men and heroes: the cult of saints in medieval Perthshire', *Innes Review*, vol. 56, no. 1 (Spring 2005), 61-88

Hallam, Elizabeth M., 'Royal burial and the cult of kingship in France and England, 1060-1330', *Journal of Medieval History*, vol. 8 (1982), 339-80

Hammond, Matthew H., 'Royal and Aristocratic Attitudes to Saints and the Virgin Mary in Twelfth and Thirteenth century Scotland' in *The Cult of Saints and the Virgin Mary in Medieval Scotland*, 61-74.

Harris, Anne F., 'Pilgrimage, Performance, and Stained Glass at Canterbury Cathedral' in *Art and Architecture of Late Medieval Pilgrimage in Northern Europe and The British Isles Texts*, 243-84

Hay, George, 'The late medieval development of the High Kirk of St Giles, Edinburgh', *PSAS* 107 (1975-76), 255-8.

Hearn, M. F., 'Canterbury Cathedral and the Cult of Becket', *The Art Bulletin*, vol. 76 , no. 1 (1994), 19-52

Heslop, T.A., 'The Canterbury Calendars and the Norman Conquest' in *Canterbury and the Norman Conquest: Churches, Saints and Scholars 1066-1109*, 53-85

Heywood, Stephen, 'The Church of St Rule, St Andrews' in *Medieval art and architecture in the diocese of St Andrews*, 38-46

Huntington, Joanna, 'David of Scotland: 'vir tam necessarius mundo'' in *Saints' Cults in the Celtic World*, 130-45.

Jamroziak, Emilia, 'How Rievaulx Abbey remembered its benefactors' in *Religious and laity in Northern Europe 1000-1400: Interaction, Negotiation and Power*, 63-76

Jamroziak, Emilia, 'Making friends beyond the grave: Melrose Abbey and its lay burials in the thirteenth century', *Cîteaux: Commentarii Cistercienses*, 56 (2005), 323-35

Jardine, H., 'Extracts from the report made by Henry Jardine, Esquire, His Majesty's Remembrancer in Exchequer, relative to the tomb of King Robert Bruce, and the church of Dunfermline, communicated to the Society on 10 December 1821', *Archaeologia Scotia*, 2 (1822), 435-54

Jordan ,Alyce A., 'The "water of Thomas Becket": water as medium, metaphor, and relic' in *The Nature and Function of Water, Baths, Bathing and Hygiene from Antiquity through the Renaissance*, 479-500

Keene, Derek, 'London from the Post-Roman Period to 1300' in *The Cambridge Urban History of Britain I: 600-1540*, 187-216

Kemp, Brian, 'The Miracles of the Hand of St James', *Berkshire Archaeological Journal*, 65 (1970), 1-19

Klukas, Arnold William, 'The Architectural Implications of the *Decreta Lanfranci*' in *Anglo-Norman Studies*, VI, 136-71

Kroesen, Justin, 'Recentring Side Altars in Medieval Church Interiors: The Example of Late Romanesque Churches in Groningen' in *The Altar and its Environment 1150-1400*, 147-67

L., Lois, Huneycutt, 'The Idea of the Perfect Princess: The Life of St Margaret in the Reign of Matilda II (1100-18)' in *Anglo-Norman Studies*, xii, 81-97

Lamia, Stephen, 'The Cross and the Crown, the Tomb and the Shrine: Decoration and Accommodation for England's Premier Sains' in *Decorations for the Holy Dead: Visual Embellishments on Tombs and Shrines of Saints*, 39-56

Lewis, Suzanne, 'Henry III and the Gothic Rebuilding of Westminster Abbey: The Problematic of Context' in *Traditio: Studies in Ancient and Medieval History, Thought, and Religion*, 129-72

Mackechnie, Aonghus, 'The Royal Palace of Dunfermline' in *Royal Dunfermline*, 101-38

MacLennan, W.J., 'Medieval Hospital in Scotland: A Cure for Body or Soul?', *The Journal of the Royal College of Physicians of Edinburgh* 2003, 33 (supplement 12), 36-41

Macquarrie, A., 'An eleventh-century account of the foundation legend of Laurencekirk, and of Queen Margaret's pilgrimage there', *Innes Review*, xlvii (1996), 95-109

Macquarrie, A., 'St Margaret of Scotland' in *The Saints of Scotland: Essays in Scottish Church History AD 450-1093*, 211-23

Macquarrie, A., 'Vita Sancti Servani: The Life of St Serf', *Innes Review* 44 (1993), 122-52

MacQueen, Hector L., 'Canon Law, Custom and Legislation: Law in the Reign of Alexander II' in *The Reign of Alexander II, 1214-49*, 221-51

Maddicott, J.R., 'Edward I and the Lessons of Baronial Reform: Local Government, 1258-80' in *Thirteenth Century England*, 1-9

Mason, Emma, 'The Site of King-Making and Consecration': Westminster Abbey and the Crown in the Eleventh and Twelfth Centuries', 57-76

Mason, Emma, 'Westminster Abbey and the Monarchy between the Reigns of William and John (1066-1216)', *The Journal of Ecclesiastical History*, 41(02) (1990), 199-216

McRoberts, David, 'Material Destruction caused by the Scottish Reformation', *Innes Review*, vol. 10 (1959), 126-72

McRoberts, David 'The Scottish Church and nationalism in the fifteenth century', *Innes Review*, vol. 19 (1968), 3-14

McRoberts, Monsignor David, 'Scottish Pilgrims to the Holy Land', *Innes Review*, vol. 20 (spring, 1969), 80-106



- Mentel, Rainer, 'The Twelfth-Century Predecessors of Glasgow Cathedral and their Relationship with Jedburgh Abbey' in *Medieval Art and Architecture in the Diocese of Glasgow*, 42-9
- Oram, Richard, 'Community and Realm: the Middle Ages' in *The Architecture of Scottish Government: From Kingship to Parliamentary Democracy*, 34-44.
- Oram, Richard, 'Introduction: An overview of the reign of Alexander II' in *The reign of Alexander II*, 1-47
- Oram, Richard, 'The Medieval Bishops of Whithorn, their Cathedral and their Tombs' in '*Clothing for the Soul Divine*': *Burials at the Tombs of St Ninian*, 131-66
- Ormrod, W. M., 'The Personal Religion of Edward III', *Speculum* vol. 64, no. 4 (October 1989), 849-77
- Palliser, D. M., 'Royal Mausolea in the Long Fourteenth Century (1272-1422)' in *Fourteenth Century England III*, 1-16
- Payne-Carter, David, 'Procession and the Aesthetics of Everyday Life of a Benedictine Monastery', *The Drama Review*, vol. 29 (3) (1985), 42-7
- Penman, Michael, 'A fell coniuracioun agany Robert the douchty king: the Soules conspiracy of 1318-1320', *Innes Review*, vol. 50, no. 1 (Spring 1999), 25-57
- Penman, Michael, 'A Programme for Royal Tombs in Scotland? A Review of the Evidence, c.1093-c.1542' in *Monuments and Monumentality in Later Medieval and Early Modern Europe*, 239-53
- Penman, Michael, 'Christian days and knights: the religious devotions and court of David II of Scotland, 1329-71', *Historical Research*, vol. 75, no. 189 (August, 2002), 249-72
- Penman, Michael, 'Faith in war: the religious experience of Scottish soldiery, c.1100-c1500', *Journal of Medieval History*, vol. 37(3) (2011), 295-303
- Penman, Michael, 'Margaret Logie, Queen of Scotland' in *The Biographical Dictionary of Scottish Women: From the earliest times to 2004*, 248-9
- Penman, Michael, 'Parliament Lost - Parliament Regained? The Three Estates in the Reign of David II, 1329-1371' in *Parliament and Politics in Scotland, 1235-1560*, 74-101
- Penman, Michael, 'Robert Bruce's Bones: Reputations, Politics and Identities in the Nineteenth Century Scotland', *IRSS* 34 (2009), 7-73

- Penman, Michael, 'Robert I (1306-1329)' in *Scottish Kingship 1306-1542*, 20-48.
- Penman, Michael, 'Royal piety in Thirteenth-century Scotland: The Religion and Religiosity of Alexander II (1214-49) and Alexander III (1249-86)' in *Thirteenth Century England*, XII, 13-30
- Penman, Michael, "'Sacred food for the soul'?: the devotions to saints or Robert I, c.1306-c.1329', *Speculum* 88 (4) (2013), 1035-1062.
- Penman, Michael, 'The Bruce dynasty, Becket and Scottish pilgrimage to Canterbury, c.1178-c.1404', *Journal of Medieval History*, vol. 32(4) (December, 2006), 346-70
- Penman, Michael, 'The Scots at the Battle of Neville's Cross, 17 October 1346', *The Scottish Historical Review*, 80 (2001), 157-80
- Perry, David, 'Dunfermline: from 'Saracen' castle to 'populous manufacturing royal burrow'', *PSAS*, 129 (1999), 779-815
- Prestwich, M., 'The Piety of Edward I', in *England in the Thirteenth Century*, 120-8
- Rawcliffe, Carole, 'Curing bodies and healing souls: pilgrimage and the sick in medieval East Anglia' in *Pilgrimage: The English Experience from Becket to Bunyan*, 108-40
- Reid, Norman H., 'A great prince, and very greedy of this world's honour' in *The Reign of Alexander II*, 49-78
- Ridyard, Susan J., 'Condigna Veneratio: Post-Conquest Attitudes to the Saints of the Anglo-Saxon' in *Anglo-Norman Studies* 9, 179-206
- Robertson, T. M.; William, G. H.; Haggarty, George; and Reynolds, Nicholas, 'Recent excavations at Dunfermline Abbey, Fife', *PSAS*, 111 (1981), 388-400
- Rollason, L., 'Spoils of War? Durham Cathedral and the Black Rood of Scotland' in *Battle of Neville's Cross, 1346*, 57-65
- Ross, Alasdair, 'The Bannatyne Club and the Publication of Scottish Ecclesiastical Cartularies', *The Scottish Historical Review*, vol. 85, no 2 (2006), 202-30
- Russo, Thomas E., 'The Romanesque Rood Screen of Durham Cathedral: Context and Form' in *Anglo-Norman Durham, 1093-1193*, 251-68
- Scholtz, B. W., 'The Canonization of Edward the Confessor', *Speculum* 36 (1961), 38-60

- Sharpe, Richard, 'The Setting of St Augustine's Translation, 1091' in *Canterbury and the Norman Conquest*, 1-13
- Shed, Norman F., 'Jocelin, abbot of Melrose (1170-1174), and bishop of Glasgow (1175-1199)', *Innes Review*, vol. 54 (1) (Spring 2003)
- Simpson, G.G., 'The Heart of King Robert I: Pious Crusade or Marketing Gambit?' in *Church, Chronicle and Learning in Medieval and Early Renaissance Scotland*, 173-86
- Snape, M. G., 'Documentary Evidence for the Building of Durham Cathedral and its Monastic Buildings' in *Medieval Art and Architecture at Durham Cathedral*, 20-36
- Stringer, Keith, 'Arbroath Abbey in Context, 1178-1320' in *The Declaration of Arbroath: History, Significance, Setting*, 116-41
- Tatton-Brown, Tim, 'Canterbury and the architecture of pilgrimage shrines in England' in *Pilgrimage: the English Experience from Becket to Bunyon*, 90-107
- Taylor, Alice, 'Historical writing in twelfth-and thirteenth-century Scotland: the Dunfermline compilation', *Historical Research*, vol. 83 (2010), 228-52
- Taylor, Arnold, 'Royal Alms and Oblations in the Later 13<sup>th</sup> Century' in *Tribute to an Antiquary: Essays Presented to Marc Fitch*, 93-125
- Theilmann, John M., 'Political Canonization and Political Symbolism in Medieval England', *The Journal of Britain Studies*, vol. 29, no. 3 (1990), 241-66
- Thompson, Benjamin, 'Free Alms Tenure in the Twelfth Century' in *Anglo-Norman Studies* 16, 221-44
- Thurlby, Malcolm, 'St Andrews Cathedral-Priory and the Beginning of Gothic Architecture in Northern Britain' in *Medieval art and architecture in the diocese of St Andrews*, 47-60
- Thurlby, Malcolm, 'The Roles of the Patron and the Master Mason in the First Design of the Romanesque Cathedral of Durham' in *Anglo-Norman Durham, 1093-1193*, 161-84
- Tongerren, Van, 'Use and Function of Altars in Liturgical Practice according to the *Libri Ordinarii* in the Low Countries' in *The Altar and its Environment 1150-1400*, 261-74
- Veitch, Kenneth, "'Replanting Paradise': Alexander I and the reform of religious life in Scotland', *Innes Review* vol. 52, no. 2 (Autumn 2001), 136-66

Wall, Valerie, 'Queen Margaret of Scotland (1070-93): Burying the Past, Enshrining the Future' in *Queens and Queenship in Medieval Europe*, 27-38

Walker, J. Russell, 'Scottish baptismal fonts, with drawings', *PSAS* 21 (1886-87), 346-448

Walker, Simon, 'Political Saints in Later Medieval England' in *The McFarlane legacy: studies in late medieval politics and society*, 77-106

Wall, Valerie, 'Malcolm III and the Foundation of Durham Cathedral' in *Anglo-Norman Durham, 1093-1193*, 325-338

Watson, G., 'The Black Rood of Scotland', *Transactions of the Scottish Ecclesiological Society*, ii (1909), 27-46

Weiss-Krejci, Estella, 'Heart burial in medieval and early post-medieval Central Europe' in *Body Parts and Bodies Whole*, 119-34

Williamson, Beth, 'Altarpieces, Liturgy, and Devotion', *Speculum*, vol. 79, no. 2 (2004), 341-406

Wilson, Christopher, 'Calling the Tune? The Involvement of King Henry III in the Design of the Abbey Church at Westminster', *Journal of the British Archaeological Association*, vol. 161 (2008), 59-93

Wright, Georgia Summers, 'A Royal Tomb Program in the Reign of St Louis', *Art Bulletin*, 56(2) (1974), 224-43

Yeoman, Peter, 'Saint Margaret's Shrine at Dunfermline Abbey' in *Royal Dunfermline*, 79-88

### **Theses**

George Joseph McFadden, 'An Edition and Translation of the Life of Waldef, Abbot of Melrose by Jocelin of Furness' (Columbia University, unpublished PhD thesis, 1952)

M. Ash, 'The Administration of the Diocese of St. Andrews 1202-1328' (University of Newcastle upon Tyne, unpublished PhD thesis, 1972)

Thomas JM. Turpie, 'Scottish saints cults and pilgrimage from the Black Death to the Reformation, c. 1349-1560' (University of Edinburgh, unpublished PhD thesis, 2011)

### **Websites**

Database of Dedications to Saints in Medieval Scotland accessed on <http://webdb.ucs.ed.ac.uk/saints/>

*Dunfermline Delivers*, 2 August 2013 accessed on <http://connectingwithyou.co.uk/news/dunfermline-museum-and-art-gallery-site-excavation>

Medieval Sourcebook: Twelfth Ecumenical Council: Lateran IV 1215 accessed <http://www.fordham.edu/halsall/basis/lateran4.asp>

*Oxford Dictionary of National Biography*, Oxford University Press, 2004 accessed on <http://www.oxforddnb.com/view/article/>

*Records of the Parliaments of Scotland to 1707*  
<http://www.rps.ac.uk/>

*The Catholic Encyclopedia* accessed on <http://www.newadvent.org/cathen>

The Holy Rule of St. Benedict, translated by Rev. Boniface Verheyen, OSB accessed <http://www.osb.org/rb/index.html#English>

The People of Medieval Scotland, 1093 - 1314  
<http://poms.ac.uk>