**Lines of Flight:
Mediation
and the
Coding of
Narrative Knowledge
on the
American Screen
in the Seventies
(2 Volumes)**



**Submitted to
The University of Stirling
In Candidacy for the Degree of
Doctor of Philosophy**

**By
Daniel Richard Fleming
May 1984**



Contents to Volume II

Part Three

4 Investigative Structure and the Spectator267
 4.1 Supposition and structuration267
 4.2 The imaginary and the analogon285
 4.3 Seriality and the problem of 'Dirty Harry'297
5 Before Our Eyes ?321
 5.1 Theoretical practice321
 5.2 Effects of R: narrative effects355
 5.3 Effects of R: knowledge effects362
6 Policing Relations382
 6.1 Fantasies?382
 6.2 Police stories392
 6.3 Intelligibility/flight434
7 Imitative Desire445
 7.1 Sovereignty/discourse445
 7.2 Triadic relationships in the imaginary454
 7.3 Oedipal resolutions471
8 Knowledge and Performance491
 8.1 Imaginatio/ratio/scientia intuitiva491
 8.2 Termination/performance517
 8.3 Authority/performance558
9 Postscript: Reading583

Part Four

10 Narrative Reasoning and Emersonian Overflowing630
 10.1 Mediation630
 10.2 The lesson of power644
 10.3 Instrumental reason and desire667
 10.4 'Resolution'699
 Notes and references to Volume II732
Bibliography756



PART THREE

CHAPTER 4

INVESTIGATIVE STRUCTURE AND THE SPECTATOR

4.1 Supposition and structuration

In considering any particular action or scene in a film one may perhaps have the right to expect that its appropriateness, its fit in the succession, will result from an inexorable tendency towards that point on the part of the accumulated actions or scenes that come before. Even in the case of a 'surprise' the unexpected will occur within certain limits determined by the cumulative effect of prior events: without such an effect there will be nothing against which 'unexpectedness' can be judged. This 'right to expect' is symptomatic of the usual reading of the dominant kind of realist narrative under consideration here. This is not to deny that there are many possible turns available to such a narrative but rather to suggest that at any one point a limited range of turns will be supposed likely. The turn actually taken will then make its own contribution to determining the set of suppositions

about the next. Cumulatively, then, a succession of actions and scenes may diverge quite markedly from other equally possible successions when considered as a whole, but at each point the divergence may in fact be strictly limited.

Within this kind of perspective on narrative, Holloway distinguishes two kinds of supposition:

'minor suppositions, which relate to what the characters will do or say next, for example, and major suppositions, which relate to the outcome and resolution of the whole tale'.¹* So reading narrative operates within two sets, the events and the suppositions, each generated out of the other after a fashion.

While one would not wish rigidly to insist on finding a system of minor and major events to correspond with the two kinds of supposition, it seems clear, nevertheless, that there is a kind of suppositional 'montage' at work, by which a set of minor events produces through their assemblage a major supposition (as when particular actions of villain and hero in a Western set them on courses leading to a supposedly inevitable showdown, which in the more routine examples of the genre, such as Duel At Silver Creek,² can be seen a long way off), or perhaps more precisely this is a matter of locating within the accumulation of minor events connections among some which lead them to take on the shape of a supposedly major event. The

* notes and references begin on p.733

pressure to find this kind of shape may be greatest in a genre such as the detective film, where one major supposition is that a mystery of some kind is there to be solved. The minor events and suppositions, in such a case, tend to fuel the mystery. Its 'solution' rests in the formulation of major suppositions to be checked against a major event (archetypally the crime) which is, so to speak, generated retroactively (or explained retroactively in the case where it has been witnessed by the audience before the detective comes on the scene) and is balanced at the other end of the chain by the apprehension of the villain, an event conventionally supposed to be concomitant with solution of the mystery. A major supposition of this kind, that solution of the mystery will entail the apprehension (and, automatically, the punishment) of the criminal if there is one, depends to a degree on a simplified notion of justice. A film such as Dirty Harry depicts the obstructions to this clear-cut approach: the suspect is released because the detective violates his rights, there is insufficient evidence of the correct kind, and so on. But the film continues to operate as if taking for granted the audience's conventional major supposition and Harry eventually kills the villain (--final enough to pre-empt any further legal niceties). Here the actions

of the district attorney and others who would defend the rights of the accused are clearly relegated to a 'minor' status, while Harry's actions, the stages by which he tracks his opponent and makes the kill, cumulatively take on the shape of a major event generated by the major supposition of an Old Testamental resolution. Thus a particular kind of major supposition structures the reading by controlling the suppositional 'montage' in order to vindicate itself. (This does not finally prevent the suppressed elements being available for re-appropriation in an oppositional reading by those who do not subscribe to such a major supposition, however strenuous the film's efforts to engage it.)

The major supposition is generated by the initiating event in the narrative of Dirty Harry, the murder of a young woman. By having the audience witness a cold-blooded criminal act in this way the supposition of detection and punishment is engaged straightforwardly as a principle of organisation in the reading of subsequent developments. What is suppressed, of course, is the unnaturally privileged position of such a witnessing: Harry tends to be absolved, even of torture, because the audience is uniquely without doubt as to where guilt (the killer) and innocence (the girl) are to be found. Were the

same audience to see instead a version of the story in which the identity of the killer and the 'innocence' of the victim remained in doubt, the relative status as read of events in defence of and in prosecution of the suspect could be expected to be very different. Evidently, therefore, suppositions can best be understood as first and foremost generated in the text rather than as 'baggage' which members of the audience bring with them. Moreover, as the film progresses there will be a certain 'weight' of supposition-generation, so that when Harry's anger leads him to abuse the suspect the pressure of the film's flow will tend to carry the audience into and past that event, with little opportunity to reflect on its implications.

If, following Holloway's general procedure, we label as 'A' the major supposition, that is the supposition that the killer will be detected, caught and convicted, then the legal details which reverse Harry Callahan's project along these lines may be thought of as generating the supposition ' \bar{A} ', the converse according to which the killer will not finally be caught and punished. At each point in the narrative one or other of these suppositions will tend to be generated according to the degree to which Harry has by that point successfully asserted himself against the 'system's' constraints. Given the likely expectations (derived largely from the Italian Westerns³ in

the first instance) which an audience will have of a character played by Clint Eastwood, the retributational killing of the villain must increasingly seem an inevitable resolution of the developing impasse between A and \bar{A} . This 'inevitability' renders the film rather less interesting than, for example, Hustle⁴ where the ambiguity around the role of the 'macho cop' in the system is more fully played out. Not surprisingly then, Hustle avoids the kind of initiating event which establishes Scorpio, the sniper in Dirty Harry, as thoroughly deserving of all Harry Callahan's less than gentle ministrations.

Where Scorpio kills a girl in a swimming pool, in Hustle there is just a girl's body washed up on the beach. The major supposition is, therefore, rather less clear-cut in this case; perhaps, 'If someone is responsible for her death he will be detected, etc.'. The 'if' here resonates throughout the film, rendering problematic the whole conventional impulse of detective fiction to 'get the story straight'.

We might usefully bear in mind Holloway's insistence that any serious consideration of supposition in narrative needs to attend to what he terms the narrative sets. In other words, the events in the narrative operate on the audience in a cumulative way, so that the fourth event should really be considered

as inextricable from the set e1...e4 and any attempt to work on narrative structure as simply an arrangement or pattern of events will be virtually useless without this sense of the accumulation of sets. Moreover, working with hindsight introduces the possibility of reading e4 in terms of a total set extending forward as well as backward from that point and, therefore, of missing the nature of the actual reading of the film as at any one moment perched, so to speak, on the end of a narrative set which is always about to extend itself. Narrative structure is then properly to be considered a series of sets rather than a single set (the film) of events. Thus, successive sets in the reading:⁵

e1				
e1	e2			
e1	e2	e3		
e1	e2	e3	e4	
e1	e2	e3	e4	e5
etc.				

Fig. 22.

An important consequence of such a perspective is that it can absolve us, for some purposes, of the prickly question of where and how to cut an event out of the flow. Where does e1 end and e2 begin? What are the 'units' of the structure? The set, for example, e1...e4 need not afford any difficulty in this.

The cut-off does not have somehow to mark an incontrovertible segmentation, but just a simple recognition that the reading of a film is produced in time and that e4 is split from e5 merely by arresting that production at a moment in time in order to do what the audience does not have time to do; to consider the set to that point without the pressure caused by its insistent extension.

Holloway broadly defines the initiating event (ei) as 'the first to propose a supposition as to outcome'.⁶ Clearly this need not be the very first thing to happen in a film but in mainstream cinema it tends to occur shortly after the beginning, as presumably the audience's anticipation is most easily aroused in this way. Both Dirty Harry and Hustle go for it straightaway. In Dirty Harry the initiating event even precedes the opening titles, while in Hustle it occurs behind the titles. There is then the likelihood, if not the inevitability, given the familiar kinds of tension on which popular narrative plays, that an event will occur to jeopardise for a time the supposition generated by the initiating event; Holloway calls this, logically enough, the reversing event (er). He represents these categories thus:⁷

Fig. 23.

el . . . ei	Ri	A
el . . . er	Rr	\bar{A}

Here A and \bar{A} are major suppositions relating to 'two alternative possible terminal sets' and R is the relation between the members of a set; 'Since in no case is it the last item, in isolation and by itself, which propones the new supposition, but rather the new member in the series of sets, we may regard the fact that such-and-such a set propones A (or \bar{A}) as a relation between the members of that set.'⁸

In the case of Hustle, where the set el...ei consists of only the title sequence of the film, we can move on fairly rapidly to the question of whether there is anything which generates a contrary supposition; that there is no one to be pursued and charged with responsibility for the girl's death and that, in short, there is no solution to the mystery beyond the 'solution' that there is no 'mystery' to be solved. This in fact occurs when Lieutenant Phil Gaines (Burt Reynolds) and his partner Louis, who are in charge of the case, report to their rather callous superior, Santoro, at police headquarters. But first, the beginning against which any possible reversal is to be understood.

ei - discovery of girl's body on the beach.
MS of body of attractive teenage girl in shallow water.
Cut to zoom in on a house in a pleasant hillside residential area. Cut to MS of a beautiful woman (Catherine Deneuve) approaching through a doorway into sunlight. (The house nestles in trees and the greenery which fills the end of the zoom matches the subdued greens of the decor in the room behind the woman.) Crane away from her slowly. Cut to (helicopter) shot pulling upwards from the balcony where she stands in LS. Cut back to slow crane-out at the same angle as the high shot but with woman in MLS; she turns to re-enter room.

Thus:

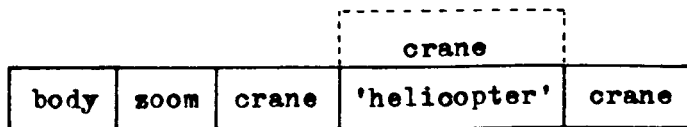

Fig. 24.

The 'helicopter' shot replaces as it were, a section of the crane shot which therefore becomes two shots while maintaining the continuity of its movement. The overall pattern of movement is this:

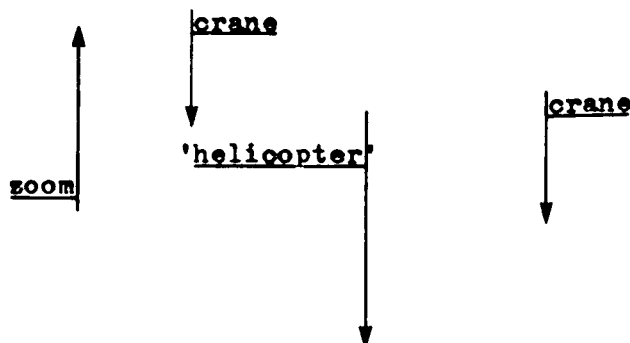

Fig. 25.

Cut to MS of woman from inside the room as she comes in from the balcony and looks off right. Cut to CS of man (Burt Reynolds) in bed looking up left; eye-line match.

Given that Burt Reynolds is recognisable to the majority of an audience who will have certain general expectations of him (basically that he is a 'tough guy' from much the same mould as Eastwood⁹), the movement from ei to a close shot of the character played by Reynolds establishes a cause-effect connection of a kind, the 'effect' being the supposition that the Reynolds character will be the one to get the story implied by ei. This is not confirmed by a given narrative connection until it is revealed that Reynolds plays a detective and he is called onto the dead girl's case. The audience, of course, does not have to wait for this narrative response to ei in order to suppose a connection between him and the mystery of the initiating event; in any case dominant cinema tends to confirm this kind of supposition almost automatically.

Then there is the manner in which the film moves from the dead girl to the Reynolds character. The woman on the balcony is placed at the centre of an equivocating to and fro movement in relation to the focussing on the Reynolds character of the anticipation which the initiating event generates, the anticipation that someone will get the story straight. The intimate relationship of the Reynolds and Deneuve characters (Deneuve's recognisability¹⁰ = supposition: 'heroine') is traversed by this movement which has its divisive 'pull'

represented by the 'helicopter' shot which wants to escape when we would most expect to be drawn inwards. The 'latent' connection between the Deneuve character and the dead girl, established by the introduction of Deneuve immediately after ei, will become a matter of this 'to and fro' movement of commitment and distance: Phil Gaines is unsure how far he wants to go in getting at the truth of the dead girl, what degree of commitment he has to that task, just as his relationship with the woman is ill-defined.

The detailed information begins to be lodged in the text: a 'phone-call causes Gaines to look for his gun, he tells the woman the call was from 'down town' and that a dead girl has been found on the beach. This is sufficient to establish that he is a police detective. We are left in little doubt about the woman's occupation; 'It's a time-honoured profession, an older one than yours.' The detective tells her what he had planned for the day: he was going to take her to a football game; 'Have you wear those tight white pants and that sexy blouse. Parade you up and down the aisle a couple of times. Watch all those guys looking at you and say to myself, "Schmuck! She's for sale!"' The elegant prostitute tells him wearily that everyone in the stadium is for sale. They stare out over the balcony rail and day-dream of escape; 'It would be nice to fly away'.

The parents of the dead girl come to identify the body. The detective introduces himself. Marty Hollinger (Ben Johnson), the father, goes to light up a cigarette but Gaines tells him that there is no smoking 'down there'. Hollinger over-reacts; 'Awh, that's bullshit!', and Gaines backs down; 'If you want to smoke, smoke'. When the girl's naked body is wheeled out of the freezer Hollinger explodes furiously and knocks Gaines to the ground. When subdued he complains, 'You should have covered her up'. Gaines responds, 'Mr. Hollinger, I have nothing to do with the procedure down here, nothing, but you're right, we should have covered her'. Shortly afterwards Gaines is told that a killer whom he had got sentenced for life has been released as 'rehabilitated' and gone on a violent rampage. What begins to become apparent is Gaines' equivocal relationship to procedure, to the 'system' (the 'rehabilitated' killer is here a kind of Dirty Harry subplot) and this is given more generalised expression when the call-girl tells him to bring home some 'dirty pictures' with the take-away meal, to which he suggests, 'How about an eight-by-ten glossy of Sammy Davis Jnr. hugging Nixon?'

That night Hollinger lies awake remembering birthday parties, days on the beach and at the funfair, the laughter of an innocent child. While the prosti-

tute, Nicole, services a client by telephone Gaines stands on the balcony and recalls discovering his ex-wife making love with another man (and subliminally the strange image of an old man dressed in black, standing among gravestones).

Gaines' equivocation about commitment comes to a head when he reports off-handedly on the girl's death to his superior and they agree to 'close it up' as just another 'simple' suicide on drugs (er). This might well be what it was (i.e. what the film 'knowingly' makes it without telling us at this stage) but the positioning of the dead girl in ei works against such an unproblematic closure and a shadow is cast across the decision not to investigate further when the senior officer asks, 'The girl's father, is he anyone?' Gains replies, 'No John, he's no one'.

Hollinger himself clearly feels that this is why the authorities are less than interested in investigating his daughter's death: 'The reason nobody gives a damn about Gloria is because we don't count'. All that Gaines can offer him by way of an alternative explanation is a feeble generalisation; 'Mr. Hollinger, suicide is the number one killer of teenagers in America today. Now I can give you statistics...'. 'I don't give a damn about statistics!' rails the bereaved father. 'Marty, it's all here. It's all

official,' his wife tells him resignedly, 'It's documented!' But he is intransigent; 'The only thing in there is what they want to put in there.' Gaines is angrily defensive and adopts a posturing righteousness; 'Don't tell me nobody cares--sometimes we don't have time to care, but we're all you've got.' As the Hollingers leave his office Gaines muses, 'Sometimes you can't tell the Christians from the lions', and this is, as much as anything, a problem of self-definition.

In dealing with the impasse which has by this point developed between the conventional major supposition generated by ei and its denial generated out of the detective's reluctance to commit himself to the investigation, the film adopts the interesting strategy of a secondary initiating event.

Immediately after Gaines and his superior decide to close the Hollinger case the film moves to a scene between Nicole and a wealthy, influential client, a powerful attorney. ('The government takes care of that', he tells Nicole when she asks if he can afford her services.) The client excuses himself at one point to make a 'phone-call to a box outside a union headquarters. The man who answers the call turns the receiver towards the building and as three men leave it to get into a car the vehicle explodes. The

client hears the blast and replaces the receiver without saying a word. Cut to Gaines' office as his partner asks, 'What about that photo?' 'You think this photo is important do you Louis?' asks Gaines with forced scepticism. The photograph, from the dead girl's wallet, is of two girls, one of them Gloria Hollinger, at a pool-side with Nicole's wealthy client. Louis calls him 'Leo, the kingfish'. Gaines tries to shrug it off ('So what?') but his partner persists and the matter is left hanging. We are given, therefore, a secondary ei to reinforce the first with another (but connected) mystery, instigated by the explosion. This works to displace the first supposition, that ei offered a mystery which would be solved, which now runs through the secondary ei and can, therefore, be held in parallel with the supposition generated by the reversing event, the closing of the girl's case. Gaines and Hollinger operate within these two suppositional 'runs' and the subsequent narrative is established on the tension between their respective positions.

What is constituted here is a secret, a hidden truth, and the tension is established on whether that truth will be revealed, as Hollinger wants, or held at a distance, as Gaines tries to do against mounting pressure. Gaines' defensive hesitancy about commitment is worked out most explicitly in his relationship

with Nicole who is the centre of his problem just as Gloria is the centre of Hollinger's. In a reflective moment, when his defences are weak (after watching A Man and a Woman) Gaines confesses to Nicole, 'I care about you but ... I'm starting to draw dirty pictures about what you do'. She is willing to give up her work but Gaines, despite the 'dirty pictures' cannot make the kinds of commitment which she is looking for. Meanwhile, Hollinger goes to the club where he has discovered that Gloria worked as a topless dancer. Watching a girl gyrate behind a translucent screen he sees his daughter dancing there. Is this the truth that he is looking for to set against the memory of an innocent child; a 'dirty picture' to rival those which are troubling Gaines? Gaines later shows him a pornographic film featuring Gloria.

Fig.26.

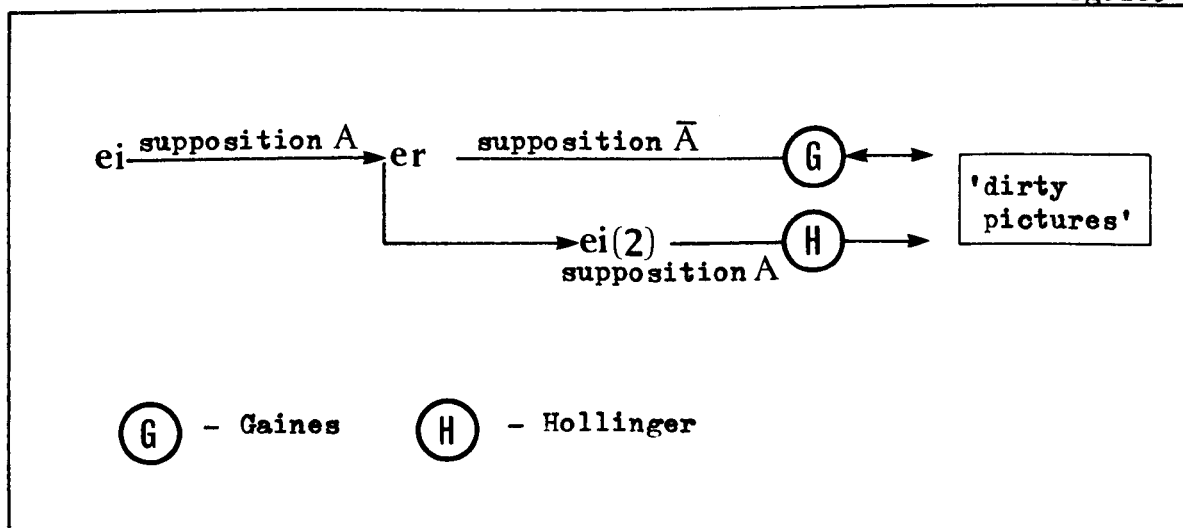

At this point, rather than continuing directly with Hustle to the stage of constructing what might claim to be an exhaustive analysis, it is important to jeopardise the neatness of such a tendency (however much it may seem like unfair abandonment, as if tempted by the promise of fresher pleasures) in order to be able to take the questions raised by a particular text and allow them some free play without the constraints imposed by the drive towards closure within dominant cinema.*

* for further consideration of Hustle, within a wider interpretive horizon, see pp.533-39

4.2 The imaginary and the analogon

We are moving into considering here several sets of seeming allusions, several 'pictures' of the American city, spaces, and social relations, which, however limited and apparently superficial or distorting, may usefully be examined to discover where they coincide or differ among themselves and whether their coincidences are sufficient to demonstrate that they are in fact details of a larger ('dirty'?) picture. If we take as the linchpins of these productions, and it seems sensible to do so, the fictional police detectives on which turn the conventional realist narratives that pass through and organise the pictured spaces, it is then possible to pose a central question. If a society has real detectives, is itself rigorously policed, why does it require (need? desire?--paradoxically only through an answer can we precisely formulate the question) these imaginary representations of detectives?

Clearly there are simple answers, the very simplicity of which may, however, be suspect. Perhaps the powerful within a society control the powerless by dominating their imaginations, by offering as truth false images of the very apparatuses, the law and the police, by which power is most obviously held in place. An active 'them' enslaves a passive 'us' through our

imaginations. Perhaps again an explanation in terms of 'them and us' is too mechanical; perhaps a society constructs these idols for itself in some process of projection or transfer. After all, no one is forced to watch a film.

Althusser offers (though not directly in relation to the cinematic) an alternative explanation to the two crudely characterised here. (These he further identifies as respectively that of the Priests and Despots with their Beautiful Lies, and that of Feuerbach, so initially influential on Marx, according to which God is the ultimate projection.)¹¹

Althusser's own explanation differs essentially in that it does not have the real, the conditions of existence, directly available for either reflection or distortion within representations. (Nor does it rely on the homogenisation of social relations into 'society', which may then as a whole be thought to do or need this or that.) Instead, what is represented is understood to be the imaginary relation of individuals to these conditions:

It is this relation which is at the centre of every ideological, i.e. imaginary, representation of the real world. It is this relation that contains the 'cause' which has to explain the imaginary distortion of the ideological representation of the real world. Or rather, to leave aside the language of causality it is necessary to advance the thesis that it is the imaginary nature of this relation which underlies all the imaginary distortion that we can observe (if we do not live in its truth) in all ideology.¹²

For an imaginary representation to work there has to be some kind of fit between it and its subjects (an audience, for instance) in their imaginary relation to actual social relations. It is Althusser's contention that such a function is carried out by rituals of recognition,* but to know these rituals, these mechanisms of recognition, is tricky:

Now it is this knowledge that we have to reach, if you will, while speaking in ideology, and from within ideology we have to outline a discourse which tries to break with ideology, in order to be the beginning of a scientific (i.e. subject-less) discourse on ideology.¹³

What is difficult in such a discourse is clearly the extent to which we live in the truth of the imaginary relation; the extent, therefore, to which such knowledge is inevitably beyond us, out of reach. Will it be this truth that any investigation inevitably uncovers; the truth written into the scenario from the beginning? Possibly what is of importance is the constant attempt to break with imaginary distortions, an attempt which might have, at best, a cumulative 'scientific' effect. In the meantime, how even to begin?

Consider Althusser again on Strehler's 'Brechtian' stage production of Bertolazzi's El Nost Milan:

* compare with the idea of the 'phatic' function, pp.233-34

Yes, the audience applauded in the play something that was beyond them, which may even have been beyond its author, but which Strehler provided him: a meaning buried deeper than words and gestures, deeper than the immediate fate of the characters who live this fate without being able to reflect on it.¹⁴

Althusser's concern is with the relation between the play performed and the audience, and particularly with a Brechtian attempt to activate that relation in a specific way. While appearing to endorse the metaphor of truth as a hidden content, he in fact goes beyond an interpretation of 'Brechtian' in terms of technical and psychological conditions, in order to recast the metaphor. For Althusser it is not just a matter of restrained acting, austere sets, the absence of a hero with whom the audience can identify, and so on. It is more (a 'more' which he finds in the actual production which deploys these elements), a 'distance' within the structure, rather than a secret content as a 'truth' in the metalanguage which claims to uncover it.

It is within the play itself, in the dynamic of its internal structure, that this distance is produced and represented, at once criticizing the illusions of consciousness and unravelling its real conditions.¹⁵

What is important at this point is not the precise nature of this 'distance' (to which we will come later)* but the fact that it is achieved within the recognition (which indeed it brings to light) which binds the audience to the production. In a cinema devoid of Brechtian aspirations we should be looking within the films themselves, in the dynamic of their structures, for the lack of distance ('produced and represented') which prevents that recognition on which the spectacle depends from coming into view and thus becoming open to doubt. It is a lack of distance which at once collaborates with the illusions of consciousness and ravel's its real conditions.

It is necessary to consider what might be meant by 'the dynamic of its inner structure' if it is to be other than the technical and psychological conditions of 'mise-en-scene' and identification. Althusser rejects two models of the spectator's position and its relation to this structure. The first is that of Judge, outside the 'mise-en-scene', assessing it; rejected 'for what else is he if not the brother of the characters, caught in the spontaneous myths of ideology, in its illusions and privileged forms, as much as they are?'¹⁶ The second model is that of identification; rejected because if the spectatorial position is that of 'a social, cultural

* see for example the 'distance' between the two planes of the spatial text, pp.718-20

and ideological consciousness¹⁷ to think it only in psychoanalytical terms would be overly reductive. Psychoanalytical terms may indeed be necessary to understand fully the relation between audience and performance but not necessarily as its foundation which is rather, and this is the model for which Althusser opts, the performance as 'the occasion for a cultural and ideological recognition'.¹⁸ It is this recognition which makes the cultural and ideological phenomenon of representation possible in the first place:

Yes, even if it is the ideology of the poor par excellence, as in El Nost Milan, we still eat of the same bread, we still have the same rages, the same rebellions, the same madness (at least in the memory where stalks this ever-imminent possibility), if not the same prostration before a time unmoved by any History. Yes, like Mother Courage, we have the same war at our gates, and a handsbreadth from us, if not in us, the same horrible blindness, the same dust in our eyes, the same earth in our mouths. We have the same dawn and night, we skirt the same abysses, our unconsciousness. We even share the same history--and that is how it all started.¹⁹

How though does the 'same earth in our mouths', which makes representation possible, come to be invested in (or invest itself in) the structures of the aesthetic object?

Couched in these terms the question hovers challengingly between what are often thought to be mutually exclusive kinds of explanation, the phenomenological and the structuralist. If (to anticipate an emphasis developed later) it is necessary to steer a course between subjectivism and the immobilization of forms and functions (and to release Althusser from structuralism's coffin) it will be useful to turn at this point to Sartre. There is the simplistic answer to the question; that the artist begins with an idea which he then realises on a canvas, in clay, with a camera, or whatever. Sartre has written as succinctly as any on this 'commonsense' conception:

This mistaken notion arises from the fact that the painter can begin with a mental image which is, as such, incommunicable, and from the fact that at the end of his labours he presents the public with an object which anyone can observe. This leads us to believe that there occurred a transition from the imaginary to the real. But this is in no way true. What is real, we must not fail to note, are the results of the brush strokes, the coating of the canvas, its grain, the varnish spread over the colours.

And then, already more than hinted at, the corrective insight;

The fact of the matter is that the painter did not realise his mental image at all: he has simply constituted a material analogon such that everyone can grasp

the image provided he looks at the analogon. But the image thus provided with an external analogon remains an image. There is no realisation of the imaginary; at the very most one can speak of its objectification.²⁰

So Sartre takes the old question of how the signifier, with all its strokes, coating, grain or whatever, can actually represent some external object, and turns it entirely around, proposing instead that the signifier is 'visited' by an image (what we might now term a reference or interpretant) of the object and that what is real is not the object 'outside' but the signifier and the analogon which it constitutes. Unfortunately Sartre's description as a whole at this point is sufficiently vague for the notion to totter on the brink of suggesting some angelic visitation by a transcendent signified. What serves finally to contest such a reading is the active role which Sartre ascribes to the spectator.

The 'visitation' occurs only when the spectator 'assumes the imaginative attitude'²¹ (in what might now be called an operation of decoding). Sartre's particular concern when it comes to considering such objects as the photographic image is with whether the same 'attitude' is assumed where any apparently arbitrary connections are replaced by a strong resemblance. A hoary question indeed. To

unpack it in a characteristically Sartrean way a distinction is proposed between imaginary and perceptual attitudes. (However strange the bed-fellows, the former will prove useful in relation to Althusser's conception of the imaginary relation of individuals to the conditions of their existence.)

Sartre considers a possible situation in which a picture is mistaken, even if only for an instant, for actual people. The recognition of 'people' is instantaneous and may be thought of as preceding (albeit in a flash, so to speak) a reading of the 'people' as actual or imaginary. Those aspects of what is seen that are instantaneously recognised in the primary stage of the reading are, suggests Sartre, capable of entering into either an imaginary or a perceptual synthesis in the final stage. In the perceptual synthesis what is seen consists in its actual materials; flesh and fabrics in the case of actual people but manipulations of light on a surface in the case of a picture. In the perceptual synthesis the picture consists in its actual materials and the technical procedures which leave their trace there. In the imaginary synthesis the picture consists of 'people'. Nor will the 'people' simply vanish when we concentrate on the materials and processes, unless we do so microscopically. The structure of the image-as-read

is, therefore, according to Sartre, strictly irrational. In a perceptual synthesis a picture is materials and the results of processes. In an imaginary synthesis a picture is an image. And once, this being the crucial point, the moment of recognition has engaged the imaginary synthesis the rationality of the perceptual synthesis is bound irrevocably into an irrational structure. Here the Althusserian sense of the imaginary offers to supplement the more casual sense. (He and Sartre at this point are both Spinozists; something to which we will return.)* This irrevocable binding of one 'attitude' into another is possible because of that moment of recognition through which both will pass, and which imposes itself like some unshakeable curse.

If we return Sartre's analysis to a world which is not made up of discrete objects, recognised one at a time, but of relationships, a tissue of recognition, then the conditions on which the existence of these relationships depends get drawn into the 'as if' of the imaginary synthesis (as if the object were ..., as if the conditions of existence were ...). Recognition is, in short, fundamentally a matter of the imaginary relation which operates through the material analogon.

* see pp.493-500

(Althusser also traces the effects of the 'as if' back to the subject, but that is another story.)

Jameson has pinpointed the generalisable importance of this Sartrean analysis, clarifying as it does the inscription of the 'outside' in the 'inside' of the cultural artefact; the inscription in the analogon which is 'that structural nexus in our reading or viewing experience, in our operations of decoding or aesthetic reception, which can then do double duty and stand as the substitute and the representative within the aesthetic object of a phenomenon on the outside which cannot in the very nature of things be "rendered" directly.'²² Such a clarification is necessary as the Althusserian conception of the imaginary deals with the presentation of actual social relations to the subject and, therefore, needs to be 'stretched' if the place of the screen within social relations (the screen as a presentation of a presentation, so to speak) is to be understood. What is being proposed is in fact a way of seeing through to its logical conclusion Sartre's description of the analogon as a material representative of the imputed or imagined relation between the aesthetic object and a real object; a conclusion dependent on the fact that the 'objects' of the 'outside' will in the nature of things be more than separate items like some still-life, will

be indeed the very conditions of existence. In working this perspective into a reading of a particular film (Dog Day Afternoon as it happens), Jameson claims to identify within the (possible) readings an anchoring structural nexus by which class relationships find representative relationships within the film. Now while not wishing directly to challenge Jameson's reading of the film at this stage (in fact it will be more a matter of modifying), it seems entirely justified to ask if it is likely that a system of terms and relationships which 'cannot in the very nature of things be "rendered" directly' should nevertheless be so neatly available, even if it 'can just as easily be ignored or repressed by its viewers as brought to consciousness'.²³ In short there is the risk here of reducing the working of the analogon to yet another secret truth held by a film, a meaning already fully worked but concealed, whereas surely it must be deeply implicated in the workings of a film which involve essentially the actual situation of viewing it? It will be helpful to maintain, for a time, the Sartrean perspective.

4.3 Seriality and the problem of 'Dirty Harry'

Whatever the similarities of the many groupings to which the members of an audience belong, in coming together before a screen they experience, or are at least encouraged to experience, their relationship to each other negatively. Undoubtedly all manner of connections exist (both in fact and potentially): positively defined groups could be established within the audience but it is not in the character of a film audience for those groups to emerge, or to 'discover' themselves. It is the film that separates the members of the audience even as they share it, and essentially this is as true of a family gathering before a television screen as it is of a cinema audience, because fundamentally both are what Sartre terms a series; a mode of co-existence characterised by the separation of the members, none requiring the presence of the others. They are an ensemble by virtue of a common object, the screen, in relation to which they are interchangeable (like women in a queue outside a bakery in Sartre's example).²⁴ The unity of the series is, in a sense then, outside the series itself; in the screen and, for our purposes, in the film-object (or the bakery).

The film produces the gathering, and does so as both a direct and an indirect relation between

the members, partly in the sense that in addition to the gathering produced at any one screening there will be, as an extension of the interchangeability which characterises this gathering, the much larger series of those who constitute the total audience for the film over time (which for any one film will eventually include both cinema and television audiences). Additionally, Sartre has a more specific definition for 'direct' as presence-based and 'indirect' as absence-based: the crucial point is that presence need not necessitate the straightforward overlapping of each other's perceptual field at any one moment, but rather that those 'present' may actively organise themselves in order to achieve some collective end. So a telephone establishes a relation based on presence, however spatially distant the connected members may be, whereas spatially distant listeners to a broadcast are an indirect gathering. There is a sense, perhaps, in which solitary individuals privately watching their own screens might seem to be a culminative working out of this logic of cinema, and the broadcasting of films by television a stage in the process to that end. It will be argued, though, that this is not the case; that what counts is the complex play of the 'one' and the 'many', along the axes set down

by Godard. The actual situation in a cinema or in front of a television screen (unless the viewer is physically alone and even then in a home the presence and arrangement of familiar/familial things all around will insist on the presence-in-absence of specific others) only pretends, so to speak, to an indirect relation (most obviously in its seating arrangement, real people facing away from each other towards an object which will be the site of a 'derealisation').

In their relation of absence, spatially distant members of a broadcast audience quite clearly cannot organise themselves to act together as a group unless some subsequent procedure is worked out:

But the important point is not whether a particular radio listener possesses his own transmitter and can make contact, as an individual, later, with some other listener, in another city or country: the mere fact of listening to the radio, that is to say, of listening to a particular broadcast at a particular time, establishes a serial relation of absence between the different listeners.²⁵

So the question of presence or absence hinges on the here and now, the actual moment of subjection to the sounds and images. At this point then, not surprisingly, we find a crucial difference arising between a bakery queue and a film audience. For the latter

there is the fact, here and now, of looking at and listening to the same object. Not an indirect gathering as strictly defined, the audience is nevertheless under pressure by the fact of looking at and listening to the film to experience itself as if it were an indirect gathering, each member 'one alone' before a screen as if every other were somehow lost to the here and now in the interchangeability which characterises the series over time. Let us register again, however, the qualification here; the suspicion that there is a kind of counter-tendency also at work, some dimly felt solidarity which makes each member prefer not to be strictly alone, a pleasure in the reduction, somehow, of the presence of others which makes their absence a delightful trick: such a tendency, if more fully theorised, might offer one key to the nature of the family setting into which a televised film is most commonly inserted.

To summarise, the members of the series before a screen tend to experience their separation as a relation of absence; they forget each other (unless bored by the film). A serial relation of presence is experienced as a relation of absence.

Housewives queuing in front of a baker's shop, in a period of shortage, are characterised as a gathering with a serial structure; and this gathering is direct: the possibility of a sudden unitary praxis (a riot) is immediately given.²⁶

So although initially unified only by an external object and therefore a series, the women are present one to another because of the possibility of becoming a group, unified from within and acting together towards some goal. Replace the shop window with a screen and provide a film for them to attend to and what would tend to occur would be the suppression of that possibility; the weakening of the relation of presence to such an extent that it is experienced, so long as the here and now is filled by the film, as absence. Of course the possibility of unitary praxis (organised group activity towards a goal) is still there somewhere, but the circumstances which come to mind (such as rioting caused by projector failure?) are those in which the film is interrupted from outside the audience. Even laughter separates; if we are conscious of it as in some sense a collective activity rather than a spontaneous and therefore separate individual response we become self-conscious, our laughter forced. This is not to say that the laughter of others cannot reinforce our response. Being largely unaware of such reinforcement is, however, a precondition for its success. (It only seems to be a collective activity to an

outsider, such as someone who has just come into the cinema.) Rare instances of supposed 'interaction' with a film, such as young American audiences with The Rocky Horror Picture Show,²⁷ are carefully contrived and a non-initiate into the 'correct' rituals feels left out. That is how such an event is presented in Fame,²⁸ where we watch the audience in the film 'interacting' with a film within a film.

This is a small but useful step in more rigorously defining what may loosely be thought of as the absorption or immersion of the audience in the film; the audience is constituted as material to be worked on in the dominant cinematic situation as we know it. Any reversal of this process, which would be the condition of unitary praxis, cannot come easily. (What kind of film would be the tool of such praxis, would be itself material to be worked on, without turning back against the audience?)

It is possible, therefore, to propose for the case of the broadcast audience that the nature of the gathering is not radically altered if several members collect around one receiver (with the proviso that there may be some 'new' pleasure, some subtle attenuation): the fact of looking and listening tends to separate them again, to make them rejoin the actually absent others. Such separation, incidentally,

may be sought as a supplementary end to that of watching a film as an end in itself (that 'end in itself' perhaps being, of course, only an imaginary unity which covers the accretion of several such 'supplementary' ends), but a knot is encountered at this point; to attend fully to a film requires separation (given the kind of film referred to) while separation as a project requires attending comparatively fully to the film!

The condition of viewing and listening to a film needs to be understood as a special case of seriality in that it provides the members of a series not just with a common unifying future, as in the case of a queue, but also with a shared present (the present of a queue being predominantly unstructured, amorphous, interrupted by reveries) and indeed with a past, a memory, as the film progresses. This is the nature of a narrative process: it unites by virtue of its past and present, traversed by suppositional patterns which take it into the future. This helps to clarify the nature of the 'slippage' by which a direct gathering is experienced as indirect, thus suppressing the possibility of group praxis: a collective united by a common future may realise its potential for structured group praxis in the vacuum of the

relatively unstructured present, but the experiencing of a film fills this vacuum and will, therefore, compete forcefully with any attempted praxis, even with a simple individual action like getting something to eat or visiting the lavatory! (Home video machines are clearly the modest beginning of a release from this tyranny, which is not to say that they are properly revolutionary...) ²⁹ Moreover, having chosen one's moment carefully so as not unduly to disturb one's own absorption in the screen (e.g. after a narrative climax when the narrative machine may be expected to 'coast' for a while), the risk of then losing one's seat (in the case of a cinema) should remind us of the extent to which scarcity, broadly defined, is a significant element in seriality. Tickets, licences, receivers, video-club memberships, and so on, are necessary to ensure a place in this particular kind of series and this necessity should not, of course, be set aside as a somehow autonomous area of organisation which has nothing to do with the actual viewing of films. It is a necessity which underpins the very seriality on which the viewing experience depends; the positioning of each member of the audience within relations of serial powerlessness, formed in conditions of enforced scarcity and founded on the separation of members before the screen.

So elaborate is the apparatus which positions people in this way, maintaining separation in a crowded cinema or in the midst of a family watching television, that it is difficult not to suspect what appears on the screen of complicity in the overall process. And complicity is indicated also by the remarkable degree of homogenisation of this 'what' despite the evident availability of alternatives. Just as a rough and ready scale may be theorised, from a large city-centre cinema screening recent releases continuously every afternoon and evening, to, at the other end of the scale, a small group of people running a film on an editing bench or video machine, interrupting, discussing, re-viewing, so one might expect there to be a corresponding scale of films made to fit formally along the first scale. In fact most films presuppose a place on the dominant end of the scale. (Even 'amateur' films pretend to such a place). This is partly what makes it continue to be dominant. Few, if any, films are made for a 'workshop' audience, however much such an audience is now possible technically. Home video technology has raised the question (if only by its very existence) of just what kind of film can best fit this newly discovered place on the scale. Given the interests involved a

fit will clearly be sought as close as possible to the pole which has over the years been bloated to Gargantuan proportions, although much of the ephemera circulating may prove in the long run ill-suited to the new found, if in effect decidedly minuscule, freedom and control on the part of the audience.

Our concern at the moment is to investigate this area of homogenisation with a view to exposing the complicity between what appears on the screen and the fixing of the audience in seriality effected by the screen itself.



'In tribute to the police officers of San Francisco who gave their lives in the line of duty'--carved in stone, this memorial as it appears in the opening sequence of Dirty Harry implies immediately a particular kind of group activity. It is the first image of the film, and the carved list of dead officers' names then rolls behind a superimposed image of a police badge which holds the centre of

the screen while bells toll on the soundtrack. Into the image of the badge dissolves that of the silenced end of a rifle, jutting menacingly through the badge towards the audience as discordant musical effects interrupt the bells. A certain ambiguity makes itself felt as the menace appears from behind the badge and an initial association of the two elements oscillates with a sense of the opposition offered by the faceless gunman to the authority represented by the police badge, its star configuration carrying a trace of the conventional lawman's badge of the Western. (The next gun to point at the audience will be Harry Callahan's, maintaining the ambiguity around the question of where the danger lies. This ambiguity is picked up in the opening of Magnum Force,³⁰ where Harry turns his gun on the audience to more insistent effect.)

A subjective shot through the telescopic sight of the rifle establishes the target as a young, attractive woman in a bathing costume. This displaces the possible opposition of police and gunman in two directions: the group of policemen becomes an amorphous, impersonal (patriarchal?) authority, while the threat of the gun becomes more personal, taking on distinctly sexual overtones. The girl bathes in a rooftop pool while the gunman keeps

the cross-hairs of his sight lined up on her body. Female voices introduce what amounts to a moan on the soundtrack, counterpointed by rhythmic percussion effects, and the separation implied by the subjective shots through the gunsight is countered by the simultaneous intimacy in the sounds of the girl's gentle movements in the water and by the use of a zoom lens to flatten space. On the impact of the bullet that kills her the girl, gasping, rolls languidly in the water.

Clint Eastwood arrives on the scene to pick up the pieces and reconstruct them. His first appearance marks the beginning of the film's credits as Eastwood's name is superimposed on his figure. The credits work a metamorphosis, shortly superimposing on Eastwood his other name, 'Dirty Harry', binding performer and role together, the former taking a kind of priority. He works silently as the credits roll, moving through the city environment eventually recognisable (to movie-goers) as San Francisco, to find the sniper's now vacated rooftop position. Harry is presented as a solitary, silent figure, whose relationship to the group represented by the names of the dead policemen is to be of fundamental importance to the ensuing narrative. In fact the film's immediate post-credits sequence

fulfills no other function in terms of the film's (and attendant suppositions') development than to clarify just this issue. And it is here, significantly, that the audience is made to look down the barrel of Harry's gun (his accompanying monologue also being reprised for the opening of Magnum Force).

Harry foils a bank-raid. The sequence juxtaposes four elements; the teeming street-life, the bank-raiders, Harry, and the police (called 'the cavalry' by Harry) whom he sends for at the beginning of the sequence and who arrive on the scene just as the action ends.

Each of the people on the street can be expected to act in a serial way (united from outside) to the kind of danger represented by the bank-raiders, who constitute a group engaged together in a definite project. As the raiders spill out on to the street the passers-by run for cover from the gunfire. Although the action of each visibly resembles that of the others, each is acting essentially for himself or herself. However, seen from outside (as by the audience) this inevitably looks as if it were a group reaction and this external viewpoint is nothing other than the recognition of both the unity that derives from the common threat and the necessity of defence against that threat. Now because such events are of

course a perennial threat, the means of defence, the police, already exist within the apparatus of law-enforcement known to the audience and by which the threatened (potentially 'everyone', for whom those represented in this instance are stand-ins) as a group survive their temporary objectification under threat. The action of the police 'in the line of duty' is, in a way, the action of the group that has newly formed in the midst of the series. It is important to recognise, though, that on the return to seriality (with removal of the threat) the relationship of the police to each member of the series (which means, in a certain sense, to each member of the audience) may be very different. In addition, if a group formed under threat were to react as a mob instead of letting the police act for them, a very different role would be cast for the police. The scene under consideration here would appear, though, to offer a fairly straightforward situation: a group firing guns on the street automatically creates the appearance of a group among those others present, for whom the police act to restore the relative stability of serial relationships (which is the stability too of the audience's position). A policeman involved in these circumstances may be understood to act because his job

puts him in a position where he is threatened along with everyone else, in terms of both physical danger and a challenge to shared values. However, we have two kinds of police here; the anonymous uniformed ones who arrive at the end, and Harry. With the raiders constituting one group and everyone else temporarily constituting another, the police may be expected to represent the second group as an extension of its temporary existence, instituted to guard its boundary. Instead we have Harry, the outsider.

There is no evidence that Harry is threatened at all and this aloof invulnerability marks the sequence visually: he moves through the mayhem with an entirely cold detachment, alarming the by-standers as much as the raiders, chewing the remains of an interrupted hamburger as he wields his Magnum. Even his wounding is a non-event, to which he reacts as if it were happening to someone else. We see him wounded in order, undoubtedly, to have this reaction exhibited rather than to suggest any vulnerability.

The sequence takes pains drastically to undermine the possibility that a series, characterised by separation and powerlessness, should project representatives of its temporary group unity fused

under threat. Instead of a 'representative' group of policemen, this function is subverted by one individual whose action would seem to be explicable only in some other terms, which may mean that it is fundamentally inexplicable except as part of the structure which fits the audience into the film.

In seriality, as a fundamental level of social collectivity, the subject is determined by the object from which the series takes its sense (e.g. the screen). Since each member of the series is replaceable in the 'classroom' of the cinema (seats in rows, interchangeable occupants meant to ignore each other; this tends to impose itself on domestic seating arrangements which are often arc-like around the TV screen, resembling the front row of a cinema balcony), the subject is one other among many others and is fixed at this level of collectivity. Overlaying levels, such as the fusion of others into a group (in response to an external threat say) which establish a sameness to override the otherness, are represented on the screen rather than experienced in front of it (unless a fire-alarm goes off!).³¹ Represented groups-in-fusion (Sartre's term)³² will be formed within a represented seriality at which level the situation of the audience will, in a sense, be

recognisable to itself (bearing in mind the imaginary nature of recognition). Any imaginary release from seriality, if it occurs at all, will then be inevitably vicarious. If we are to begin to understand what is going on when Harry Callahan dominates a scene such as the bank-raid, we need to consider the question of violence in relation to the group as represented on the screen for an audience fixed in seriality.

That an audience tends to get 'caught up' in action such as this seems entirely evident. The scene tends to quell any restlessness (strategically important no doubt at this early stage in the film), people are unlikely to leave their seats during it, and it may be followed by a visible and audible relaxation. This reaction is related to the violence of the represented situation, but 'violence' in a more broadly conceived sense than simple physical conflict (among characters and in the physical cutting together of sounds and images in jolting ways); a broader sense which includes the actual relationship which obtains between screen and audience.

Nothing--not even wild beasts or microbes--could be more terrifying for man than a species which is intelligent, carnivorous and cruel, and which can understand and outwit human intelligence, and whose aim is precisely the destruction of man. This, however, is obviously our own species as perceived in others by each of its members in the context of scarcity.³³

In a period when scarcity, at whatever level (including scarcity of time, for example, at complex levels), is particularly keenly felt, we perhaps become especially preoccupied with these demonic doubles, but it would be simplistic to see them only in the screen's villains and their violence. A wider perspective is necessary.

Subjection to the machinery of the screen is part of a larger pattern. The world as everywhere marked by human activity is predominantly a world of machines, including the machinery of institutions and the media, which, though obviously made and in a sense empowered by people, are cut off from them by a seemingly inevitable and anonymous inertial quality. This occasions the degrees of powerlessness which are experienced in relation to so much of contemporary life, from public transport to television flow. At its simplest level, that of the serial relationship, sociality is produced by such things (waiting for a bus, and so on) and this

is fundamental to Sartre's insistence on the implication of matter and human activity. The indifference and powerlessness of seriality is a matter of routine in a world of things ('man' being the thing of other things) and their exigencies. It is not, however, the whole story.

Sartre's types of social formation, from series to group and so on, do not necessarily represent a sequential movement. Certainly an historical process may appear to work its way through the various stages (as would seem to be suggested by Sartre's account of the French Revolution)³⁴ but they are really 'stages' only in understanding that movement and strictly the categories are superimposed, and therefore in a sense simultaneous, in a complex structure.

It is to this simultaneity that we need to attend, as it informs the positioning of each member of an audience as a reader in a gathering of readers centred on what is read by each separately. To displace things as the centre of social relations, which is precisely what does not happen in front of a screen (itself a thing) is to attempt an escape from the mutual indifference and inadequacy of seriality, most fundamentally in response to a challenge (which the screen as we know it does not

offer) requiring collective action. But just as, in the purely formal sequence of events, there must be a moment of seriality within such a group formation, so this moment of seemingly 'pure' affiliation will be drawn into a formation rendered more elaborate by obligations, procedures, rules. An audience is always already bound by these. The 'original' moment of affiliation is past: for most members of an audience it will have been past when they were born. These constraints maintain affiliation when the immediate goal is achieved or recedes and seriality re-emerges. (An extreme but illustratory form of this re-direction of activity away from some external goal or threat and towards the group itself is a bureaucracy intent almost exclusively on its self-maintenance.)

This then is the beginning of violence within the group (whether law has been established or not). The threat of dissolution from within is controlled by a pledge or oath with its attendant symbols (flag, badge) and by a degree of intolerance towards those defined as deviant. The definition of deviance, including the selection and creation of news of deviance and the fictionalisation of deviants (villains, 'baddies') is a key factor in defining the limits within which the pledge is understood to be

operative. ('Is this the last outpost for the Western hero--killing homosexuals to purify the cities?'--Pauline Kael³⁵ on the treatment of homosexuality in Dirty Harry, Magnum Force and The Enforcer.) The pledge is either an explicit ceremonial action or an implicit realisation that a bond exists among the members of a group. It is a commitment to remain the same, to be a good American for instance, (to repress otherness within and to maintain the group as an end in itself against the possibility, rather than the actuality, of a threat from otherness without). If the Same is to ensure its survival it must maintain that commitment, which it does by violence within itself, by censure and purge. So the possibility exists that an audience, caught inevitably in seriality and living in the simultaneity of these formal structures, may temporarily recognise itself in the represented series under threat on the screen but with the removal of the threat may read the police in terms of this 'internal' violence, a violence which always already exists for an audience in the social relations waiting to re-claim them when the screen goes blank; indeed may even read the police as fundamentally alien with their own pledge, the 'line of duty', and symbol, the badge. One mechanism by which such

a reading is displaced is precisely the hero, the 'inexplicably' detached individual, the Harry Callahan who is also the Clint Eastwood, the star.

In the long run, therefore, the group (as a stage which members of an audience or their ancestors have 'theoretically' gone through in order to qualify to be an audience in the present, that is to live contemporary social relations 'naturally') must reinforce its basic integrative practices if it is not to fall apart. It must, in other words, institutionalise itself. This is the inexorable process of cooling-down from the original fusion under threat, and the cooler it becomes the tighter the grip of its various integrative practices will tend to be on the members. An audience before a screen set up in the midst of these practices will, however, repeat the slide from 'hot' to 'cold' with a rapidity un-matched in actuality, because its arousal (though neurologically real) is achieved vicariously and 'cold' is its 'natural' state. It will tend, therefore, to be capable of reading and evaluating the represented violence of integrative practices for what it is and of relating it, indeed, to those practices in which an audience finds itself. Put at its simplest, the audience positioned by the screen in

seriality cannot be expected necessarily to 'identify' with a group, the police (controlling, investigating) which at times of relative security (which is the very time of watching a film, its dangers arousing without actually threatening) makes visible the violence within.

If what the screen does with this problem were understood, answers might be available to the several questions which we have raised around the idea of the contact, as a factor in communication and as a function of (in, around) the text. These, then, are questions which point both to an area 'inside' the text, traversed by the investigative structure with its attendant suppositions (such as looking for a hidden truth to uncover), and to an area 'outside' where the audience is fixed in seriality. They point also to the necessity of defining the nexus in the viewing experience which marks the intersection of these areas, and which is precisely the working of the contact, fitting and holding the audience and the film together in an imaginary synthesis.

If we understand violence (which Sartre calls 'bourgeois exis',³⁶ an inert condition opposed to praxis) to be constituted by the various practices aimed at stabilising, regulating, legislating, holding seriality in place, then the screen

as we know it is itself a perfect violence, maintaining the illusion of comfortable solitude within the 'many' with the complicity of those (its things) on whom it operates so successfully.

CHAPTER 5

BEFORE OUR EYES?

'I prefer commencing with the
consideration of an effect' (Poe)

5.1 Theoretical practice

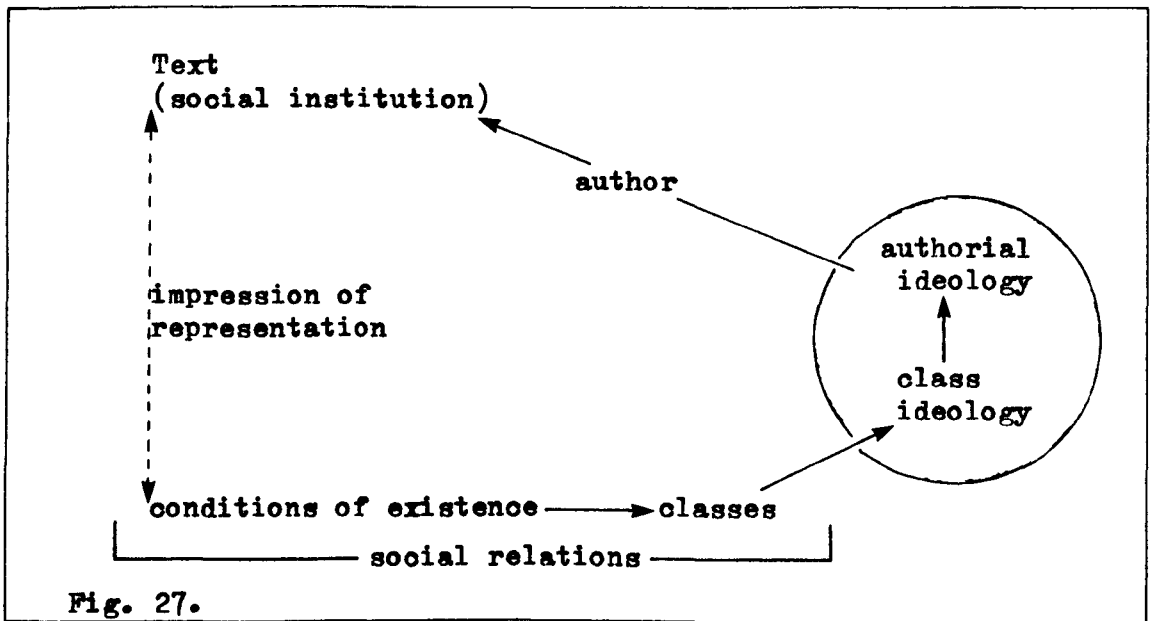

Fig. 27.

From 'social relations' to 'text', from 'text' to
'social relations'; even if only as a starting point,

modelling the problem in this way can create its own difficulties. It offers the (only illusory) possibility of an external perspective on the problem, whereas the very drawing of the model is caught up somewhere in the complexity of the referent. (Why draw it in the first place?) The circle is a crucial area within a theoretical practice which finds one mode for itself in textual criticism, but others in kinds of biography and psychoanalysis (and not always compatibly). For the textual critic, questions of authorship and conventions arise from there as do, more generally, questions of class and ideology. The problem is, in short, that of the mediating terms which prevent any simple correlation of social and textual facts, bearing in mind also that such terms as 'society' and 'text' are in a certain sense empty categories which cannot properly themselves begin to be filled until the mediations begin to be theorised. The circle, the ground of ideology within the model, puts at issue the author's relationship to a class (answerable perhaps to those biographical and/or psychoanalytical approaches) and the relationship of the text in turn to that (primary? founding?) relationship. Are these connecting relationships to be conceived of

in terms of reflection, of representativeness? Is there, in a sense, a space of ideology within the text which reflects/is representative of the circle which appears in the model? A second, 'inner' circle?

But because the work of formulating a model and the work of criticism which motivates such a formulation are embedded in what is modelled, such questions are not as innocent as they appear. They are inflected by certain situational choices, principally the choice of authors and texts. 'Don Siegel' has more presence, more authority, indicates something apparently more exceptional and presumably therefore less representative, than 'Richard Irving' within the field at hand, for example. And if Dirty Harry tends towards the exceptional ('wizardly' for Pauline Kael,^{1*} implying that Siegel is the 'wizard') while an 'Irving' episode of The Name of the Game or The Six Million Dollar Man² tends towards being unexceptional, representative, then what are the implications for an attempt to theorise the mediating terms of the model? Is there some kind of implicit scale of admissible evidence at work which allows The Six Million Dollar Man to tell us chiefly about the kinds of ensemble within the social formation that constitute the audience for this kind of entertain-

* notes and references begin on p.735

ment, whereas Dirty Harry can be appropriated for a theory of authorship which allows it to tell us chiefly about its author's peculiarities and world view, surreptitiously severing the chain of connection between text and social relations at the point where it passes through the author (and ignoring, therefore, the social relations of consumption). On the other hand if the relationship of a class to the social formation is thought in terms of certain problems and contradictions, perhaps Siegel's peculiarities, his 'individualism', mark a confrontation with these (around the second, 'inner' space) whereas the various productions in which Irving has been involved merely occlude the problems?

What it comes down to is that the choice of texts and authors, and the status accorded them ('quality' leading to only certain kinds of reading for instance) will determine the model developed (even if the model appears to precede a choice, because for work such as this certain pre-judgements are inevitable; those which may inform the 'innocent' choice of Siegel and Irving as examples being a case in point). In particular that choice will have a determinative effect on the ways in which the hypothesised space of the second circle, the within

of the text, will be filled. So what is being produced, the text by 'society' or vice versa? In fact the question of situational choices forces a change in the direction of the arrows entered on the diagram at the beginning of the chapter. This reversal is a recognition of our own movement on the terrain described by the model, a movement which begins with the text and only then hypothetically restores a context in which author, class and social relations find their places.*

This does not necessarily entail that the social 'reality' thus approached has in fact no reality outside the discursive practices in which the text is located. If some aspects of Althusser's work draw cultural studies into that sort of impasse, it will be suggested in the following chapters that they are condensable within, and largely confinable to, a final phase of his epistemology, the re-working of which will not invalidate the remainder.

The strategy throughout Part III is to displace the text and the conditions within which it is produced and consumed, into a general consideration of apposite social relations and their conditioning. What will emerge will be, therefore, a theoretical context within which

* see Chapter 10

authors and classes might be located, although this work of detailed location will not be directly undertaken for the moment. In brief, a principal object of study will be the formal milieu in which the impression of representation establishes itself. The development of a theoretical practice sensitive to this milieu, and to the ideological dimensions within it, necessitates a consideration of Althusser's theory of knowledge.

Theoretical production's original precondition is a set of 'facts' which are in fact partly ideological notions, according to Althusser. This is inevitable for as long as there is theoretical work to be done.

This first generality (which I shall call Generality I) constitutes the raw material that the science's theoretical practice will transform into specified 'concepts', that is into that other 'concrete' generality (which I shall call Generality III) which is knowledge. But what, then, is Generality I, that is, the raw material on which the labour of science is expended? Contrary to the ideological illusions--illusions which are not 'naive', not mere 'aberrations', but necessary and well-founded as ideologies--of empiricism or sensualism, a science never works on an existence whose essence is pure immediacy and singularity ('sensations' or 'individuals'). ...It does not 'work' on a purely objective 'given', that of pure and absolute 'facts'. On the contrary, its particular labour consists of elaborating its own scientific facts through a critique of the ideological 'facts' elaborated by an earlier ideological theoretical practice. To elaborate its own specific 'facts' is simultaneously to

elaborate its own 'theory', since a scientific fact--and not the self-styled pure phenomenon--can only be identified in the field of a theoretical practice. In the development of an already constituted science, the latter works on a raw material (Generality I) constituted either of still ideological concepts, or of scientific 'facts', or of already scientifically elaborated concepts which belong nevertheless to an earlier phase of the science (an ex-Generality III). So it is by transforming this Generality I into a Generality III (knowledge) that the science works and produces.

But who or what is it that works? What should we understand by the expression: the science works? As we have seen, every transformation (every practice) presupposes the transformation of a raw material into products by setting in motion determinate means of production. What is the moment, the level or the instance which corresponds to the means of production, in the theoretical practice of science?³

Althusser's answer to his own question is, in the body of the text, somewhat vague and cyclical. The 'moment, the level or the instance', the Generality II which completes the schema, is 'the corpus of concepts whose more or less contradictory unity constitutes the "theory" of the science at the (historical) moment under consideration', but in a footnote Althusser admits to a problem here:

This Generality II, designated by the concept of 'theory', obviously deserves a much more serious examination than I can embark on here. Let us simply say that the unity I am calling 'theory' rarely exists in a science in the reflected form of a unified theoretical system...Usually it is made up of regions locally unified in regional theories that coexist in a complex and contradictory whole with a theoretically unreflected unity.

This is the extremely complex and contradictory unity which is in action, in each case according to a specific mode, in the labour of theoretical production of each science.⁴

This mode of production, whatever its nature, relates an area of the already thought, the already uttered (rather than some underlying and directly encountered reality) and an area where this is re-thought, re-uttered. The content of the latter is achieved upon the 'facts' of a previous phase, now stripped of their old content and re-worked in order to express the new content of a more recent phase of theoretical development. The expression/content model is useful because it emphasises that the worked over object is not raw matter ('real world'/'knowledge'). Althusser's description of Generality I at a particular moment as constituted by a Generality III of a past moment suggests, as all thought is through signs, that the overall scheme into which the description fits is that of staggered systems of signification. In order to clarify the operation of staggered systems Barthes adapts Hjelmslev's 'ERC' notation; the relation (R) of an expression-plane (E) and a content-plane (C).⁵ The expression-plane constitutes the raw material which the relation transforms into specified content, or in the case of Althusser's description

of theoretical practice the expression-plane consists in ideological 'facts' which the relation (according to a specific mode of production) re-arranges and transforms into knowledge. When such knowledge is subjected to a further process of elaboration it will become an ex-Generality III which is the Generality I of a succeeding phase.

This persistent elaboration may be understood according to Barthes' formulation of 'two systems of significations which are imbricated but are out of joint with each other', the 'out-of-joint' representing the very movement of theoretical work. (There are serious difficulties with Barthes' own superimposition of 'denotation' and 'connotation' on this outline, as Hervey suggests.)⁶

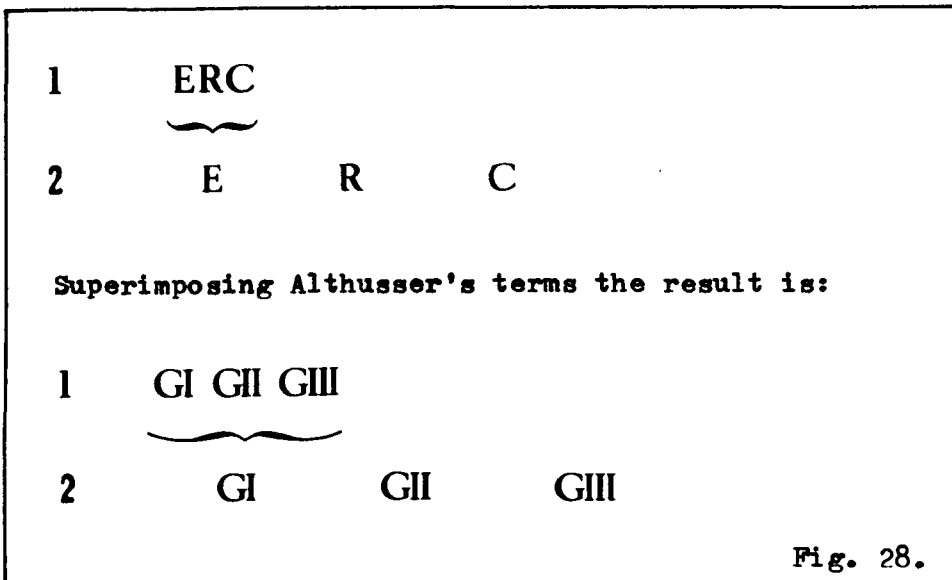

Imbricated systems represent the systematic ordering of areas of social heteroglossia, to use Bakhtin's term:

Instead of the virginal fullness and inexhaustibility of the object itself...[there is] the unfolding of social heteroglossia surrounding the object, the Tower-of-Babel mixing of languages that goes on around any object; the dialectics of the object are interwoven with the social dialogue surrounding it.⁷

When, according to certain norms of coherence and corroboration, an area of discursive practice crosses the thresholds of 'epistemologization' or 'scientificity', Althusser's imbricated Generalities represent the consequent ordering and, to a degree, the suppression of competing 'voices'. Bakhtin captures precisely, however, the sense in which GI always slides under GIII as a constant threat to the latter's authoritative and undialogized language: 'every extra-artistic prose discourse--in any of its forms, quotidian, rhetorical, scholarly--cannot fail to be oriented toward the "already uttered", the "already known", the "common opinion" and so forth.'⁸ Representing Althusser's description in this way clarifies the ideological character of GI at each phase: it is not simply an ex-GIII because a GIII must always be understood as already constituted by

a GI and a GII. At each phase GI is nothing other than the previous, or preconditional, phase in its entirety.

What might this mean for a theoretical practice which constructs itself in relation to film? More exactly, what are the implications for that 'in relation to'? Some of these might be clarified by a consideration of various options for critical practice, bearing in mind that in a certain sense any critical text may be a site traversed by elements of ideological and theoretical practice in complex and inevitably contradictory relationships. As a case in point we will re-consider the piece by Anthony Chase, 'The Strange Romance of "Dirty Harry" Callahan and Ann Mary Deacon'.

Chase, not to put too fine a point on it, brands Dirty Harry a 'necrophiliac, fascist love poem' and 'sick and profoundly dangerous'.⁹ His text is particularly interesting, therefore, primarily because its worried tone implies a potential effect for the film and thereby opens on to an area apparently outside the film itself. Chase's strategy for doing so involves a distinction between 'implicit' and 'explicit' content. He reads the plot as essentially contrived in order to provide occasions for violent action (the 'explicit' content) and then reads the action in terms of an underlying meaning (the 'implicit' content):

The visceral thrill which attaches itself to each violent demonstration of Dirty Harry's masculine morality, his enormous and decisive capacity to obliterate a perverse and chaotic social menace, has in its origins a complex and intricately developed psychological terror: the fear of erotic sexuality.¹⁰

There is a distinct suggestion here of something else; the phallic reverberation of 'masculine' and 'enormous' which pick up on the overriding image in the publicity for the film--Eastwood wielding a huge handgun. There is also, as Chase goes on to acknowledge, the Fiedler thesis of which its original proponent himself states, 'It has survived into a new literary era and will, I trust, continue to flourish in a new cultural climate, which indeed it may have helped to create'.¹¹ Indeed it may, and we should therefore register the beginnings of a suspicion on these grounds. Put quite simply there is a crucial difference between a pre-Fiedler and a post-Fiedler work which fits his thesis. To shift the thesis forward in time and re-apply it to the cultural artefacts produced during the period elided by the shift necessitates consideration of the possible influence of the thesis on the intervening cultural production, and also, crucially, of whether Fiedler may not be participating in some broader phenomenon which explains the 'accuracy' of his thesis.

Chase quotes Fiedler on the American novelist's supposedly compulsive tendency to create 'women' who are rather 'monsters of virtue or bitchery, symbols of the rejection or fear of sexuality'.¹² Fiedler in fact locates the beginning of this tendency in the figure of Rip Van Winkle and, a crucial and influential formulation, in 'the flight of the dreamer':

Ever since, the typical male protagonist of our fiction has been a man on the run, harried into the forest and out to sea, down the river or into combat--anywhere to avoid 'civilization', which is to say, the confrontation of a man and woman which leads to the fall of sex, marriage and responsibility.¹³

What is striking is the obvious applicability of this to so much of American film, from the male bonding of Butch Cassidy and the Sundance Kid¹⁴ to the flights 'down the river or into combat' of The Deer Hunter and Apocalypse Now,¹⁵ and in Siegel's directorial work to such 'monsters of virtue or bitchery' as the women in The Beguiled¹⁶ or the widow in The Shootist. In fact it is the very obviousness of all this to which we should perhaps be attending. Strange that an 'implicit' content, which can be turned around to condemn as sick and dangerous the very work which contains it, should in fact be so obvious, even so explicit.

Fiedler furnishes Chase the possibility of reading Dirty Harry alongside Poe, and in pinpointing the burial-alive of Ann Mary Deacon (which will be re-considered later in other terms) as the aspect in which the film somehow reveals itself, Chase collapses 'Siegel' into 'Poe', or vice versa:

Annabel Lee was entombed by the sounding sea while her equally virtuous sister, Ann (as in Annabel) Mary (as in Virgin) Deacon (as in the Church) is buried down by the San Francisco Bay and as one gothic image survives in another, Roderick Usher becomes Harry Callahan, tormented by a faint yet irrefutable sound (dare I say it?) as if her frail body might have been placed living beneath the ground! and Dirty Harry (whose wife, taken from him for no reason, tragically evoked with funeral parlour phrases: 'Forgive me, I'm sorry, I didn't know', as if out of respect for her stilled virtue) sees in this horribly threatened child no one but his own dead bride, born never to know evil, and could secretly confess, like the narrator of 'Ligeia' that 'my memory flew back (Oh, with what intensity of regret!) to Ligeia, the beloved, the august, the entombed. I revelled in reflections of her purity...'17

What is significant here is not so much the absence of any open indication in the film that Harry does see his dead wife in the threatened child (with all that the Fiedler thesis would imply for that conjunction) as the way in which this reading is so neatly held in place just below the surface, like Ann Mary Deacon herself, with all the points

marked out for a perfect mapping of 'explicit' and 'implicit', as if it were a secret (sexuality repressed by Harry/the film/Siegel: the only good woman is a dead woman, at least from the waist down) which Dirty Harry knows itself to contain and actually dares the reader to uncover. The film keeps dropping clues (catalogued by Chase), like a criminal who wants to be caught, who knows his guilt and secretly wishes to be exposed. Meanwhile, perhaps, it is doing something else entirely?

It is this underlying meaning, however, that Chase sees as constituting a dangerous influence on an audience, an audience finally embodied for Chase in the figure of William Calley who, though not mentioned by name, is invoked as a victim of a kind in Chase's summation;

Clearly, the tough guy is being played for a sap: he has no idea what a real woman is like, gets hopelessly stuck on some boring assembly line in Detroit with the only possible escape to Vietnam where he can spend an hour with a whore when the MP's aren't looking and outside My Lai have the most sexually gratifying experience of his life, the machine-gunning of a hundred men, women and children in a ditch. Some romance.¹⁸

This establishes a circuit. It starts with a theorisation (essentially Fiedler's, although as we noted earlier Reich is brought in to tidy things up) of the American imagination broadly conceived, continues to a reading (in this case Chase's own)

of a particular cultural product (Dirty Harry) in terms of that theorisation, and on through to 'real life', to social relations and the aberrations caused therein (at their worst, My Lai and the like) by the working out of the forces which have been theoretically recognised and critically exposed. And it is a circuit which one would so like to accept. Every point in the diagram which opened this chapter could be implicated in a unified pattern (and as for class ideology, one American critic has usefully pointed out; 'we have our own lower classes outside the national borders'¹⁹--in Vietnam for instance). The text could be found guilty of promulgating and encouraging (behind the thinnest of disguises) the new fascism, and of having corresponding and real effects.

What is troubling here is not precisely any one step in the circuit (there are circumstances in which Fiedler's insights can be illuminating, Chase's reading seems to fit Dirty Harry in a number of ways, Vietnam veterans have testified to the influence of the movie tough guy on their attitudes);²⁰ but the circuit as a whole depends essentially and inevitably on an Althusserian Generality I; the notion that certain identified patterns (a supposed ex-GIII) of sexual repression indigenous to the

American imagination can form the inner meaning of a particular work and result in undesirable effects in 'real life'. Many of the elements of Chase's reading are accurate within certain limits, but what he makes of them as a whole is shaky: instead of working on the supposed connections across the various elements of his GI, Chase lets them run in parallel through to his conclusion. Whatever there is of ideology in the GI is, therefore, allowed to slide across these strands and may in the end only have changed position.

An implicit theoretical practice in Chase's text seems to inform the apparently logical development of the argument, which in fact takes for granted (in defiance of Althusser's prescription of what a GII should do) its nodal points of connection, as among Fiedler, Dirty Harry, and My Lai. A notion such as the 'flight of the dreamer' does not simply remain unchanged as it is shifted between levels here. Nevertheless, by looking outside the film to its supposed effects Chase organises his reading around the largely unspoken theorisation of the connectedness of underlying meanings, film and social relations. Going back a step, we can see that Chase's implicit theoretical practice is based primarily, again following the

Althusserian model, upon Fiedler's thesis as refined into apparently usable knowledge (GIII) which has been cut free from Fiedler's actual practice (GII = Love and Death In the American Novel) and the raw material, the work of particular American writers (GI) with which it engaged. Chase's Generality I, thus constituted by these preconditional Generalities without which he would have no argument, is then worked on by his critical reading of Dirty Harry in order to produce the 'knowledge' of how this film ('and, we would like to argue in detail, most of the male action cinema')²¹ can be 'profoundly dangerous'. To do this Chase needs to take on board the supposed result (as much a 'climate', Fiedler admits, as a set of facts) of Fiedler's work on literary texts, and our suspicion that much the same process may have occurred in the construction of the object of Chase's attention, Dirty Harry, raises the important question of the availability of such work to appropriation across a range of discursive practices. What then is the status of the result (GIII?) of Chase's work? Has the transformation, on which Althusser's concept of 'real' theoretical practice hinges, in fact occurred?

It is necessary to consider the nature of the transformation which intervenes between Generalities I and III. There is a first instance which must be allowed for even if we do not expect to encounter it--'this border-line case of a purely ideological raw material, a hypothesis which allowed me [Althusser] to introduce the science/ideology antithesis, and the epistemological break',²² but, more generally, preconditional theoretical elaborations are 'englobed' or assigned a relative and subordinate validity as they are replaced in the ascent by a new theoretical generality. Where then is the 'real' within such a transformation? Not, Althusser contends, on one side of a distinction between a concrete-reality and an abstract-theory but rather in 'the reality of scientific practice, the validity of its abstractions and ultimately the reality of that theoretical "concrete" which is knowledge'.²³ So the real is nowhere and everywhere, a richly suggestive paradox which we will return to in relation to Marx's own work (but an idea often cheapened by Althusser's detractors who read it only in the terms of his structuralist error and the border-line case); nowhere as the immediacy of an objective given (a kind of 'original' GI) but everywhere glimpsed in the mediacy of practice (GII) and in the concrete in thought which is knowledge (GIII).

GI is not given but results from imbrication upon imbrication. There is, in this sense, no Edenic fruit:

Generality I, for example, the concept of 'fruit', is not the product of an 'operation of abstraction' performed by a 'subject' (consciousness, or even that mythological subject 'practice')--but the result of a complex process of elaboration which involves several distinct concrete practices on different levels, empirical, technical and ideological. (To return to our rudimentary example, the concept of fruit is itself the product of distinct practices, dietary, agricultural or even magical, religious and ideological practices--in its origins.) So long as knowledge has not broken with ideology, every Generality I will be deeply impregnated by ideology, which is one of the basic practices essential to the existence of the social whole.²⁴

Every GI ; and the break is only a border-line case, a hypothetically clean ideology/knowledge split which Althusser would regret formulating in structuralist terms. Against such a synchronic formulation this passage already clearly presents a diachronic movement which is that of a succession of semiological systems, the second in each pair of which may be understood to work on and derive from the first through the 'mediacy' of a specific mode of production. GI and GIII are, as we have seen, profoundly unstable categories as every GI is already constituted thus:

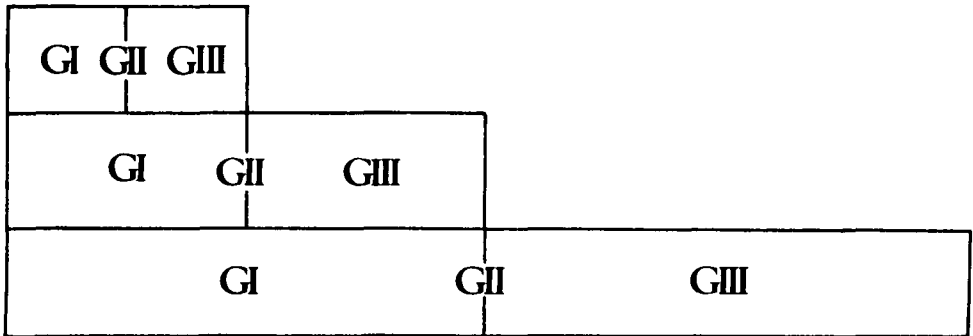

Fig. 29.

If the accumulation of 'unstable' categories is temporarily removed the mode of production which structures them may be represented in this way:

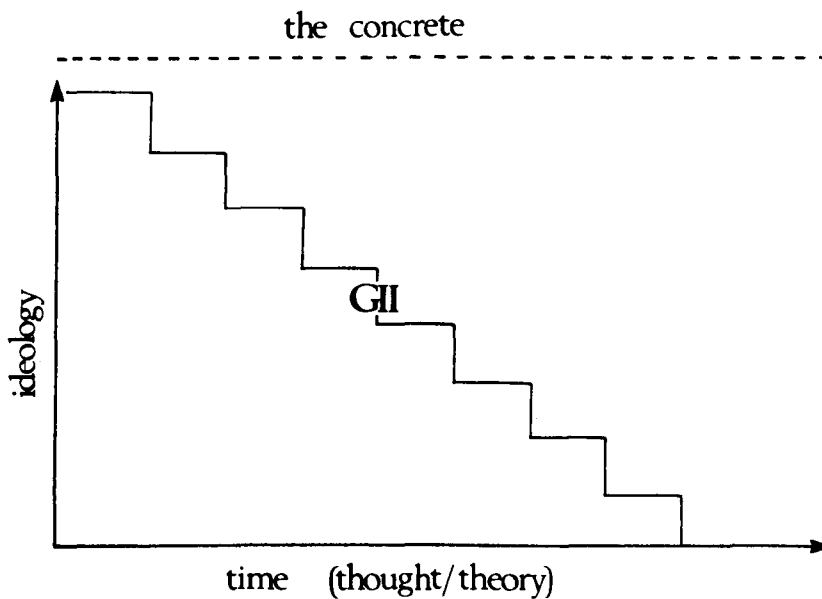
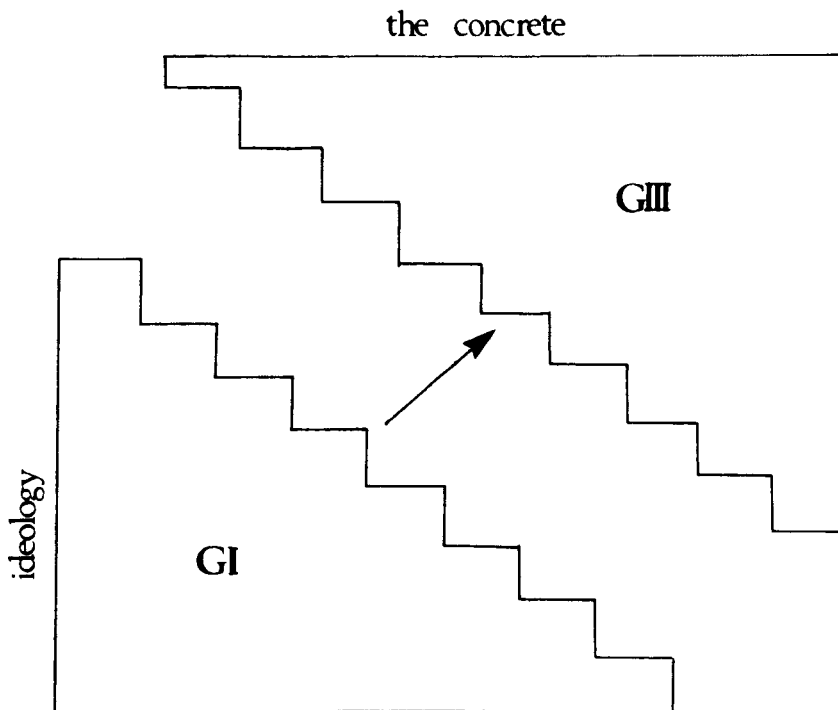

Fig. 30.

In the 'becoming' by which theory is always attempting to break with ideology, below the staggered line is the 'space' of the raw material on which theoretical practice works and above it is the 'space' of the concrete in thought, or knowledge (spatialization throughout being, of course, metaphorical). The overall 'shift' within knowledge (as distinct from the actual movement of theoretical work represented by the line 'descending' from the concrete social ground to thought) is in effect the detachment of knowledge from ideology and its attachment instead to the concrete. There is, then, a kind of 'ascent':

Fig. 31.



The transference of raw material from 'below' to 'above' corresponds to the 'method of ascending' described by Marx: 'the concrete appears in thinking as a process of summarization, as a result, not as a starting point, although the concrete is the actual starting point and hence also the starting point of perception and conceptualization.'²⁵ It is the binding of perception into the imaginary that the ascent has to work against. Or, in Althusser's terms, it is the inadequateness of GI to its objects that GII 'reveals and removes by the transformation of Generality I into Generality III'²⁶ (and, of course, the new GI will then have its inadequateness revealed and removed...).

The kind of running transformation being argued here precludes any sudden break from inadequateness and rather, returning to the example of 'fruit', knowledge comes not from swallowing it whole but from a process by which the various practices mentioned by Althusser are in a certain sense more adequately interbedded (not just a naive parallelism) by a confrontation with the contradictions among them (contradictions which make one 'level' interrupt another, suggesting always another site); so that 'fruit' is an

increasingly adequate conceptualization to the extent that, ascending from the immediate 'recognition' where it hangs on the tree, such contradictions as exist between, for example, the dietary and magical practices which traverse the conceptual site, are grasped and transcended.

The implications of this for a textual, rather than a simple conceptual, site are fairly easy to identify. It is vital to expose to these implications, and to critical scrutiny in general, the kind of circuit through which, by a final brutal connection, Dirty Harry is interpreted as 'dangerous'. This is no less so when the scrutiny comes from a position of 'left pessimism' broadly comparable to Chase's than it would be for those who argue for the innocence of mere entertainment or, more subtly, for the compartmentalization of bourgeois disciplines which allocates a text to one and social reality to another. It is, in fact, particularly important from a position responsive to Chase's fears about such cultural products, that the model used to articulate such fears be thoroughly tested, lest it divert attention from some less mechanical relationship between the text and its social ground. Some such relationship may in the end reveal a less obvious, more insidious

'danger'. But it may also reveal areas, however limited, of potential freedom for the text; areas towards which it (but not in the shape of Dirty Harry)^{*} might rise in modest revolt.

Chase establishes a parallelism of 'facts', such factual events as My Lai being aligned with the 'facts' of Fiedler's thesis and the supposedly implicit 'facts' of Dirty Harry. The circuit by which these are connected depends on each 'fact' being supposedly a homologue of the others. What is repressed is the tripartite constitution of each known 'fact', including even the atrocity in Vietnam which is available to us only as heavily worked over by journalistic practice. Chase relies on the substance of their apparent factuality (and pleased at comprehending this substance we may be so excited as to take it for granted that we assent) to establish, almost of its own volition, connections which it should be the work of a theoretical practice to explore. Chase, in fact, begins to develop a process of transcoding with which to articulate his different types of object but mistakes this for a recognition of the same 'message' in each case. (We should recall Greimas' semiotic square, where the kind of 'homology' that holds between various investments of the square is in terms of a methodological coding of semiotic possibilities and not of any actual identity of invested content.)

* on, however, this aspect of the four-film cycle initiated by Dirty Harry see pp.546-557 and 725-728

The implications of Althusser's epistemological scheme for interpretive theory include, therefore, an emphasis on 'deconstructing' what might be taken for 'facts' into their tripartite constitutions. Dispersed throughout the present study is, in fact, just such an operation on the three types of object aligned by Chase and the different structural levels to which each belongs: the cinematic text, the 'flight of the dreamer' and, crudely, the new fascist mentality.

The more general question needing to be broached at this stage is that of the relationship of theoretical practice to the other levels constitutive of social practice in general. The relationship, according to the Althusserian way of thinking, consists in translating a problem from within one or other of these practices on to the level of theoretical practice, which is not to say that a problem encountered on another level may only be 'solved' by such a shift. (Mesmer's practice was based on an occult notion of a 'fluid' by which sun, moon and stars exerted an influence. But his technique was basically sound and it was through hypnotism that Freud first approached the unconscious. Moreover, 'Freud strove throughout his life to make the theoretical superstructure of

psychoanalysis consistent with the constantly developing results of its practice'.)²⁷ It is rather a matter often of making a solution which already works on some non-theoretical level also work within the concrete in thought. A difficulty, much like that of the relationship of a map to a terrain, does arise here but is elided by Althusser in his description of the theoretical expression of a solution already practically recognised;

But this simple theoretical expression of a solution that exists in the practical state cannot be taken for granted: it requires a real theoretical labour, not only to work out the specific content or knowledge of this practical resolution--but also for the real destruction of the ideological confusions, illusions or inaccuracies that may exist, by a radical critique (a critique which takes them by the root). So this simple theoretical 'expression' implies both the production of a knowledge and the critique of an illusion, in one movement.²⁸

Our spatialization permits this 'one movement' to be graphically represented thus (although there is a difficulty about the direction of the arrow, to be broached in 5.3):*

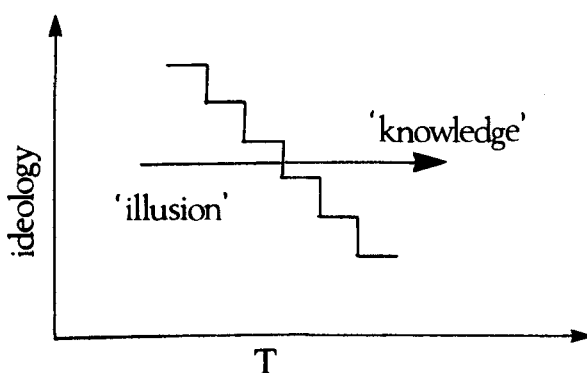

Fig. 32.

* see pp.363-78

Such a movement from illusion to knowledge, such a clean break of 'content' from the 'expression', and therefore from the ideological underpinnings (the staggered line of practice marking the point of breakage where the movement crosses it), makes sense only within a miscognition of the framing axes, which replaces the scale of inadequateness with a free-floating Ideology and the temporality of practice with a free-floating Theory. Such structuralist Manichaeism would preclude the historical process of imbricated systems. Just as an entirely un-thought, Ideological relation of 'man' and world may be understood as merely a speculative alpha-point which precedes, as it were, the Fall into language which initiates social practice, so we may understand Theory to be an equally speculative omega-point, the Revelation of a totally thought relation. If we are to understand the dynamic effects of the inevitable historical placement of a moment of practice, between Fall and Revelation, past and future must, in a certain sense, be drawn into line as traces of what has been and anticipations of what may be.

So a moment of practice is informed by deposits and suppositions, by what looks like a representable history which traverses the moment in

an inexorable movement from the anterior to the ulterior. The 'impossibility' of the angle of the Althusserian movement ('the production of a knowledge and the critique of an illusion') in relation to the systems of social practice of which it is ostensibly a part (the 'impossibility' precisely of a direction marked out on a map to which an actual movement within the constraints of an actual terrain can only hope to approximate) marks nothing other than this drawing into line to in-form the current situation with traces, with deposits and suppositions, survivals and anticipations (of, ultimately, other modes of production).

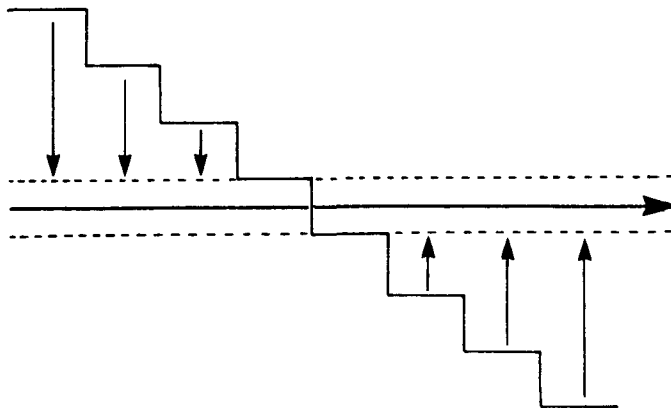

Fig. 33.

An echo of Ideology and an anticipation of Theory frame this drawing into line, in both the pictorial and the criminal senses of 'frame'. Althusser's structuralist error was in trying to actualise Ideology and Theory and the 'break' between them, trying to make it into a real history, an attempt which had its own ideological effects as Althusser was to recognise. There are consequences here for the study of any texts, aesthetic or theoretical, and the question of 'breaks' which supposedly mark the production of knowledge; consequences which point to a position such as Foucault's:

To seek in the great accumulation of the already-said the text that resembles 'in advance' a later text, to ransack history in order to rediscover the play of anticipations or echoes, to go right back to the first seeds or to go forward to the last traces, to reveal in a work its fidelity to tradition or its irreducible uniqueness...these are harmless enough amusements for historians who refuse to grow up... .

Archaeology is not in search of inventions; and it remains unmoved at the moment (a very moving one, I admit) when for the first time someone was sure of some truth; it does not try to restore the light of those joyful mornings. But neither is it concerned with the average phenomena of opinion, with the dull grey of what everyone at a particular period might repeat. What it seeks... is to uncover the regularity of a discursive practice.²⁹

From the figure above the possibility arises, and may be briefly mentioned, that the accumulation of traces below the line may be read as GIs, their theoretical constituents (GIIIs) lost in a kind of 'social amnesia',³⁰ while the accumulation of traces above the line may be read as GIIIs, their ideological constituents (GIs) similarly repressed. The second instance is, in effect, that of myth as described by Barthes, in which the complex systems of an expression-plane and a content-plane as related at a particular level are held to constitute not the expression-plane of a succeeding system but a 'total term, or global sign',³¹ a kind of fossilized Althusserian GIII. (In this sense 'Althusserianism' offers a myth of theory) Between these possibilities, theoretical practice may be understood as inevitably bound to other practices by, so to speak, a discursive weft, which delimits what it is possible to say, to mean, on any one site (about 'fruit', for example, or a text, but 'site' also in the sense of the place where a statement is made--the university, the laboratory, the cinema--and implying a corresponding status for the speaker). As Sekula puts it, 'In a very important sense the notion of discourse is a notion of limits. That is, the overall discourse relation

could be regarded as a limiting function, one that establishes a bounded arena of shared expectations as to meaning.'³² A discursive practice (as a strand of the weft) may work across the apparent boundaries of other practices, re-grouping, adjusting, working on what it finds there. In this way the discursive practice which we are beginning to detect in and around the idea of the flight of the dreamer, a practice represented (rather than exposed) at one point by Fiedler's work, may intertwine its way through critical, theoretical, cinematic and other practices in such a complex way, leaving and re-entering each at various points and in various guises, that for it to be allowed to provide 'facts' for one practice to use on another is to miscognise entirely the relatedness of practices, variously symbiotic or antagonistic, within an arena of continuous struggle; a relatedness dependent, one might say, on the 'in-formation' which the discursive weft provides.

What the 'drawing into line' effects seems to be a kind of narrative of theoretical progress, a history which is representable in terms of certain events and characters. There is nothing innocent in the choice of terms 'deposits' and 'suppositions' in this context. If we recall the

earlier use of Holloway's analysis of narrative structure it is possible to assimilate to the current perspective the fact that each new event (e) is perched at the end of a narrative set (s);

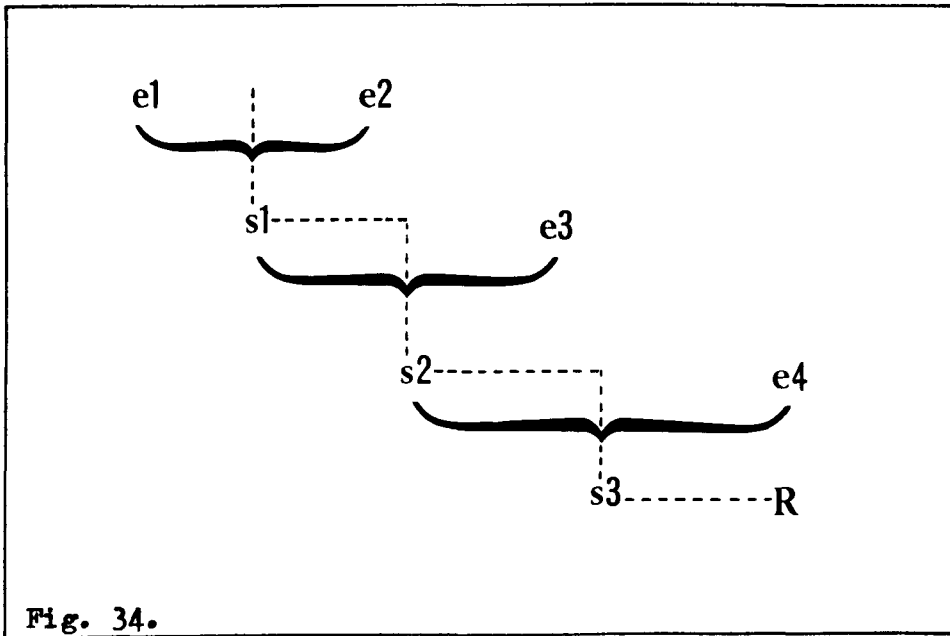

The staggered line represents the extending relation (R) between the members of each set. It is this relation that generates suppositions, just as GII generates an anticipation of knowledge as the obverse of the survival of inadequateness. The narrative's continuity, which is precisely what R represents, depends on the re-activation of deposits and their channeling in particular directions, prescribing certain limits for subsequent developments.

Where these limits effect a convergence, as is the case with the investigative structures of the conventional detective story, they would claim to offer an access-to-truth (Dr. Richman's 'I got the whole story', in Psycho) as the production of a knowledge and the critique of an illusion in one sweeping narrative movement. Now the problem with a movement aimed at getting the theoretical story straight, a tendency towards which has been a characteristic of 'Althusserianism', can best be emphasized by returning to Althusser's own counter-emphasis on the accumulation of distinct practices on different levels to effect 'a complex process of elaboration' to which theoretical practice then addresses its own 'extremely complex and contradictory unity'; ('Let us simply say that the unity I am calling "theory" rarely exists ...').³³ To subject this area of discursive complexity and contradiction (amenable to 'archaeology') to the logic of a narrative is dubious at best. The concealed problem here which, once recognised, brings the matter into sharper focus, is that we are dealing with R's effects, the appearance of sweeping movements across the field, whether in the sense of what Althusser terms a 'knowledge effect' or (within the specific area of operation of Holloway's categories) a narrative effect.

5.2 Effects of R : narrative effects

Consider the opening sequence of Bronk.³⁴ An air traffic controller has taken the eponymous detective (Jack Palance) out on the runway in a light plane to pass on information about a drug-smuggling operation in which he is involved. Bronk glances nervously around; 'We're not taking off?' This pre-title sequence operates in two ways: it sets up ei, depositing sufficient information for the audience to understand what is happening when Bronk and his partner subsequently stake-out an aircraft hanger (they are hoping to intercept a heroin shipment), and in addition it establishes a current of barely controlled anxiety on Bronk's part, expressed here as a definite phobic anxiety about flying. Palance's style of performance is particularly suited to the expression of this undercurrent: he shows here the kind of rugged surface (Sp. bronco = rough, sturdy) with momentary flashes of inner stress which characterise James Stewart's performances for Anthony Mann.³⁵

When the bags of heroin are intercepted Bronk flushes the contents down a toilet. The succeeding plot development is, therefore, centred on an absence (recognised as such only by Bronk and the audience). The heroin can be neither

re-gained by the criminals nor used as evidence against them but everyone else in the film behaves in accordance with these two possibilities, their interactions structured around a missing centre. The film elaborates this centrality of absence; Bronk's wife (like Harry Callahan's) is dead and behind the titles he moves around an empty house, and his daughter has suffered brain damage (in the accident which took her mother's life); she is catatonic, her voice is absent. So there is a visible guilt here, the heroin-smuggling, but also perhaps an invisible guilt, the source of Bronk's anxiety. Bronk is a controlling force, blocking the flow of heroin onto the street (and the supposed dissoluteness which it would occasion there) and damming-up his own anxiety, retreating into himself, speaking less and less as the film progresses, fighting some dimly perceived defensive action. 'You're putting words into my mouth', he complains at one point. 'Someone has to!' comes the reply.

The initiating event, the interception of the heroin, culminates in the accidental killing of Bronk's energetic young partner by a frightened elderly security guard. Bronk's placement and his mood lie somewhere between these two; hostile

defensiveness mixed with a crusading will to do his job properly. That the resulting stresses are close to the surface is revealed by his manic blustering as he tries to get the doctors to save his already dead partner. He hopes for the same miracle for his daughter's living death, reading signs of improvement where the doctor is pessimistic. For Bronk things must be because he wills them to be. He demands life for his dead partner. He demands an improvement in his daughter's condition. It hardly matters that the drug haul is not his to dispose of. It is his heroin by an act of will just as he would have his heroine by an act of will; the teenage daughter whom he remembers (like Marty in Hustle) as if she were still a child. It is as if in willing her to remain a child (he takes a furry toy cat to the hospital) he has trapped her in amber; seeking both to preserve the child, and yet to have her returned to life. This double-bind is echoed in Bronk's public role. Doing his job as a detective leads him to work alone outside normal procedures, suspecting everyone including his superiors, so widespread does he believe the corruption to be. He is, therefore, stripped of his badge and gun, the signs of his status, through being true (as he sees it) to that status. Bronk vs. Corruption. 'Pure!'--Bronk's partner, moments

before his death, passes judgment on the heroin. For Bronk it is 'pure' corruption, so, ignoring the other's objections, he destroys it. The narrative hinges, therefore, on two essentials, rigidly designated; the heroin as the essence of corruption and the heroine as the essence of incorruption.

The narrative effect in Bronk is the fixing of these essences. Bronk's actions throughout the narrative constitute a kind of scouring operation to reveal the underlying disposition of the supposedly essential within the inessential, behind appearances (like the corrupt city officials whose names Bronk wants). The fixed disposition of these essences realizes the trace of the narrative operation which claims to uncover them. This is Bronk's discovery.

Discovery should be taken in its most literal sense: removing the covering, as the husk is removed from the nut, the peel from the fruit, the veil from the girl...³⁶

We will employ the term 'essentiality' here to indicate an element or property which appears to claim for itself that it could not fail to be this way, except by not existing. Thus for example, the heroin in this instance is given to be such

that it could not have had other than the quality of corruptness. Much of the work of a text may go into establishing this kind of spurious essentialism.

Neither of the essentialities here has strictly any literality, any substance. The heroin is flushed out of the diegesis. The heroine is a catatonic shell. When Bronk finds his home vandalised as a warning, he rushes frantically to his daughter's bedroom, its inner sanctum, where he finds a doll broken in two, its hollowness revealed. It is in the foreground while he stands in the background, which is how we often see him with his daughter. His panic subsides, however, when he discovers his daughter's cat (to which he is allergic; again the double-bind) its unspoiled whiteness rhyming with the whiteness of the girl's room (in the house and in the hospital) and being finally returned to her lap, metonymically, as a soft lifeless toy. Where there is a hole in the doll, an apparent lack, Bronk fixates on an essence which has no literality and which cannot, therefore, be torn apart by the corruption brought into his house by the villains (which means, in a sense, by the whole outside world for Bronk puritanically suspects corruption everywhere). Relieved, he lies on his daughter's bed fondling her cat.

The film plays an interesting trick around this absence. We see, at one point, Bronk saying goodbye to his daughter after a visit to the hospital. We see past her expressionless face in the foreground to the door through which Bronk leaves. Then we see his car leaving the hospital grounds as another, which has been parked nearby, turns in through the gates. Two men whom we recognise as villains approach the girl's room. They enter through the door which we have just seen Bronk use on his way out. The girl is not there. They open the door to leave and are confronted by Bronk (with an armed assistant assigned to him by his friend the mayor, whom he half-trusts). As Bronk approaches we see his face bearing down in a subjective shot.

Clearly on one level Bronk has simply proved his cleverness at staying one step ahead of the crooks, but the girl's vanishment works more forcefully than this, suggesting that, like the vanished heroin which the villains are also looking for, she is the locus of an untouchable essentiality, of one term in the opposition corruption/incorruption. As absences both the heroine and the heroin are known not as objects, but in their effect, in the deployment of antagonistic forces which take their bearings

from these loci. And, crucially, the girl can only be seen, not heard; she is not allowed a voice, otherwise she might say what she wants (rather than what the father wants), she might give the whole game away:

Charcot sees, Freud will hear. Perhaps the whole of psychoanalysis is in that shift. Seeing is believing: Charcot's greatest error, he becomes a spectator, he believes what he sees, gives demonstrations, publishes photographs; hearing is doubting: Freud's--difficult and hesitant--move, all the cinema is banished, no photographs, opposition to the various proposals for filming psychoanalysis, only a private room, the patient immobile on the couch, a voice starting and stopping and drifting and cutting across itself with new stories, difficult questions, lapses and erasures.³⁷

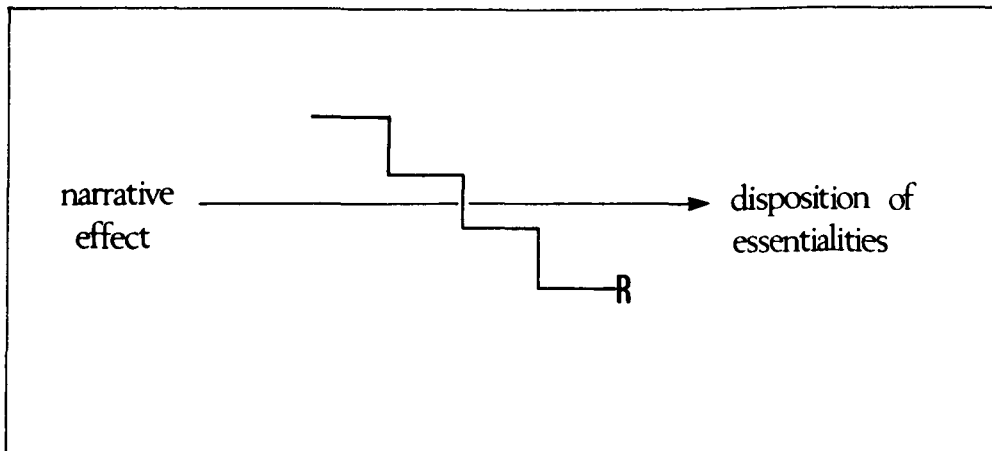

Fig. 35.

5.3 Effects of R : knowledge effects

'He was correct, practically',³⁸ says Sartre of Marx, while Althusser on a similar tack states of Engels and Lenin, 'They knew that the Marxist dialectic existed in Capital, but only in a practical state':³⁹ so Sartre and Althusser are in agreement on this key point and it is in fact the beginning of Althusser's reading of Capital and of Sartre's massive project in the Critique; historical materialism 'has established everything except its own existence'.⁴⁰ Their respective trajectories are, however, tangled (the kind of problem described so well by Hofstadter)⁴¹ in the very space where such an establishing could occur. Timothy Reiss provides a useful perspective on this space.

What I intend by the term 'discourse' can be approached through what is, at best, but a metaphor concerned with spatiality. I take the Cartesian cogito ergo sum as the paradigm of this metaphor. Within this phrase is set up the image of an ideal self: perceiving, enunciating, and conceiving. The cogito, as simple thought, is put into a discursive relationship with the sum as simple being. Taken separately, these two elements of the paradigm are without meaning; the connecting ergo gives that meaning. The triple set provides the exemplary analysis whose projection is our own epistemological process: the place of simple thought, the space of mediation, the place of (concrete) existence.

I refer to the second as a 'space' rather than a 'place' because it is not conceived of as a definite entity/substance, as are the other two. It is taken as that area in which they are put into contact with one another, and where they are taken as explaining one another... Where the other two elements are 'substance' (in whatever specific sense of the term may be implied) the ergo is supposed as an indifferent, or transparent, mediator whose presence does not affect the 'real' nature of the other two ... [However] we may say that they only 'exist' by virtue of the discursive ergo.⁴²

There is the possibility here of two 'movements' across the intervening space, from one place to the other, two directions. (Indeed as we have drawn it in 5.1 our spatialisation allows--at the risk obviously of being overly schematic--the recognition that the direction in which the movement into GIII actually works may be a source of confusion.)* In 5.1 the knowledge effect appears simply to correspond to the 'one movement' from ideology to knowledge, but Althusser's own discussion of it as an effect has it working in precisely the other direction. As it appears in 5.1, the arrow would extend backwards to some 'native land' or 'original ground'⁴³ from which it stems and one set of answers to the tangled question of the mechanism of the cognitive appropriation of the real would have the arrow of the knowledge effect running through a series of mediations ('as bricklayers make a chain to pass

* see p.347

bricks')⁴⁴ from that genesis: 'In all these cases, a real, concrete, living original is made eternally and integrally responsible for the knowledge effect...'⁴⁵ Instead Althusser understands the arrow to run in the other direction, 'scientific discourse' itself producing the knowledge effect by its internal consistency. Now Althusser does not claim a great deal for this reversal of perspective; only 'to give the first arguments towards a sharpening of the question we have posed, and not an answer to it'.⁴⁶ It is instructive, however, to consider just what it is that he hopes to have avoided; principally the supposed corruption of pure theoretical practice by other practices, an impurity which he consigns to 'gestatory sciences',⁴⁷ and which is licensed, according to Althusser, by much contemporary philosophy, holding sway 'even over its most honest and generous representatives such as Sartre'.⁴⁸ He goes on; 'By avoiding this market-place of egalitarian practice, or, as it has to be called in philosophy, of "praxis", we have won through to a recognition of the fact that there is only one path before us, a narrow path certainly, but an open, or at least openable one'. In a more specific guise the impurity is the taint of

subjectivity against which Althusser would elevate --along the narrow path--the theorist to an 'external' position. The perspective from this position seems to find its field of view troubled by Sartre once again; 'It is no accident that Sartre, and all those with none of his ability who feel a need to fill in the emptiness between "abstract" categories and the "concrete", abuse the terms, origin, genesis and mediations so much'.⁴⁹ If the suspicion arises here that Sartre's 'ability', 'honesty' and 'generosity' are being set aside both perfunctorily and uneasily it is perhaps because, once again approaching the schematic simplification, Sartre may be seen to have raised a third possibility for the 'movement' which Althusser calls the knowledge effect; neither simply in one direction nor the other but rather a kind of loop or oscillation which Sartre refers to as the progressive/regressive method. There is, in other words, no place for Sartre within the kind of opposition proposed by Althusser between subjectivity and (Kantian) objectivity.

Before considering Sartre's alternative directly, it is necessary to consider the operation of abstraction to which Althusser particularly objects. This will clarify the nature of the process to which 'Althusserianism' (as an

elaboration of Althusser's structuralist excesses) explicitly or implicitly opposes Theory, that is Marxist philosophy as the theory of theoretical practices. The process to which Althusser objects claims to be a real abstraction:

What does a real abstraction actually mean? It accounts for what is declared to be a real fact: the essence is abstracted from real objects in the sense of an extraction, as one might say that gold is extracted (or abstracted, i.e. separated) from the dross of earth and sand in which it is held and contained. Just as gold, before its abstraction, exists as gold unseparated from its dross in the dross itself, so the essence of the real exists as a real essence in the real which contains it. Knowledge is an abstraction, in the strict sense, i.e. an extraction of the essence from the real which contains it, a separation of the essence from the real which contains it and keeps it in hiding....In every case, this separation, in the real itself, of the essence of the real from the dross that conceals the essence, imposes a very special representation both of the real and of the knowledge of it, as the very condition of this operation....Knowledge: its sole function is to separate, in the object, the two parts which exist in it, the essential and the inessential--by special procedures whose aim is to eliminate the inessential real (by a whole series of sortings, sievings, scrapings and rubbings), and to leave the knowing subject only the second part of the real which is its essence, itself real... . The inessential part occupies the whole of the outside of the object, its visible surface; while the essential part occupies the inside part of the real object, its invisible kernel. The relation between the visible and the invisible is therefore identical to the relation between the outside and the inside, between the dross and the kernel. If the essence is not immediately visible, it is because it is concealed, in the strong sense, i.e. entirely covered and enveloped by the dross of the inessential. That is the only trace of the knowledge operation--but it is a trace realized in the respective positions of the inessential

and the essential in the real object itself; and at the same time it establishes the necessity for the operation of real extraction and for the scouring procedures indispensable to the discovery of the essence. Discovery should be taken in its most literal sense: removing the covering, as the husk is removed from the nut, the peel from the fruit, the veil from the girl...⁵⁰

Knowledge is in this sense a function of the disposition of parts, the structure, of the real, whereas the structuralist Althusser would seek to establish knowledge as a function or effect of the disposition of parts, the structure, of 'real' scientific discourse.⁵¹

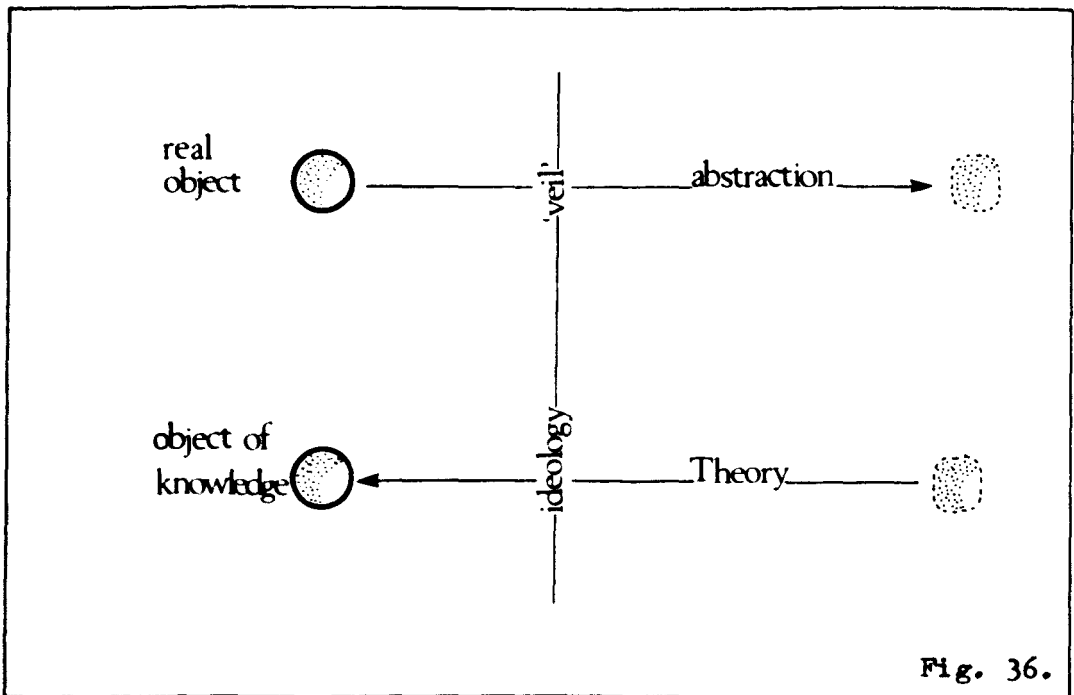

Fig. 36.

Althusser summarizes the (basically structuralist) position in this way;

Knowledge working on its 'object', then, does not work on the real object but on the peculiar raw material, which constitutes, in the strict sense of the term, its 'object' (of knowledge), and which, even in its most rudimentary forms of knowledge, is distinct from the real object.⁵²

What is 'discovered', otherwise, is something already produced 'by extra-theoretical instances and exigences (by religious, ethical, political or other "interests")'.⁵³ Althusser seeks to replace such covert production with the theoretical mode of production of science which does not merely recognise a 'discovery' imposed in advance. So from the point of view of the second arrow the first only claims to be pointing the other way while, in fact, covertly producing its object, finding what it wants to find, what it is interested in finding. Now this is astute as far as it goes, but it rejects an operation which is also rejected by Sartre who does not, however, find it necessary to go to the opposing, dogmatic extreme. For from outside its own perspective there are no guarantees that the second arrow will not lead merely to what it is interested in finding, 'essences' again, but this time in another place, the place of Theory, of the investigator outside the investigation.

So in considering the human being itself as an object, Sartre remarks that the task of producing knowledge of it would be simple, 'if one could bring to light some sort of human essence; that is, a fixed collection of determinations in terms of which one could assign a definite place to the objects studied'.⁵⁴ However, 'it must be understood that there is no such thing as man; there are people, wholly defined by their society and by the historical movement which carries them along...'.⁵⁵ Indeed, 'the concept of man is an abstraction', and, in watching the labour of a gardener and a road-mender, Sartre insists further:

I discover them as they make themselves, that is, as their work produces them; but to the extent that I cannot see them as ants (as the aesthete does) or as robots (as the neurotic does), and to the extent that I have to project myself through them before their ends, in order to differentiate their ends from mine, I realise myself as a member of a particular society which determines everyone's opportunities and aims; and beyond their present activity, I rediscover their life itself, the relation between needs and wages, and, further still, social divisions and class struggles.⁵⁶

What is Sartre doing here if he is opposing abstraction (of 'truth' in the concrete) without setting up a detached other place, a place of pure theoretical structure (of 'truth' in thought)? In

general terms, Sartre sees his task as a kind of philosophical anthropology, historical and structural, and states unequivocally, 'Anthropology will deserve its name only if it replaces the study of human objects by the study of the various processes of becoming-an-object'. Further, 'There is no doubt, indeed, that Marxism appears today to be the only possible anthropology which can be at once historical and structural'.⁵⁷ But due to its historical development, according to Sartre, 'despite itself [i.e. what Sartre takes to be its principles] Marxism tends to eliminate the questioner from his investigation and to make of the questioned the object of an absolute Knowledge'.⁵⁸ When the phenomenological perspective corrects this imbalance, as Sartre intends that it should, existentialism will disappear into Marxism; 'It [existentialism] is a parasitical system living on the margin of Knowledge, which at first it opposed but into which today it seeks to be integrated'.⁵⁹ Even this is, perhaps, to set up certain boundaries (within boundaries, etc) too firmly; 'I do not like speaking about existentialism. Inquiry ought to be indefinite: to give it a name and a definition is to button it up; and what remains of it then? A past, peripheral cultural

fashion, not unlike a special kind of soap...'.⁶⁰
(Equally applicable, of course, to structuralism.)
Rather the phenomenological perspective should be understood as the necessary regressive moment within the loop, within the cross-references as it were, of the progressive-regressive method. It is the regressive moment that returns, not to the abstraction but to the person defined by social relations, to the gardener and road-mender, 'as they make themselves, that is, as their work produces them...', and as they comprehend their own actions.

To recapitulate a little, what Reiss refers to as 'our own epistemological process' embraces apparently opposing traditions, underpinning which he detects a type of discourse informing such particular discourses as theatre, fiction, science, criticism, and so on: whether it is the place of thought or the place of the concrete that is privileged, the same idea of truth is constantly operative. So the empiricist position according to which, crudely, the concrete 'explains' thought, and the Kantian position in which thought imposes its categories on the concrete, are opposed within the same discourse of truth which insists on a place which is independent of expression, which is, in short, unmediated. That another discourse is

possible, Reiss suggests, is indicated by advances in the philosophy of quantum mechanics which include 'the observer, inventor of discourse and experiment, within the experiment itself'.⁶¹ This avoids the Kantian position of external observer, a position which, as Sartre argues, has led Marxism into dogmatism. Though with a flourish of exaggeration, no doubt, and perhaps seeing an overall state of affairs in a particular tendency, Sartre makes his objection entirely clear:

Marxism possesses theoretical bases, it embraces all human activity; but it no longer knows anything. Its concepts are dictates; its goal is no longer to increase what it knows but to be itself constituted a priori as an absolute Knowledge.⁶²

Specifically, Sartre insists, 'The only theory of knowledge which can be valid today is one which is founded on that truth of micro-physics: the experimenter is a part of the experimental system'.⁶³ For Sartre this is the basis of a non-essentialist theoretical practice which avoids any (structuralist) tendencies towards a non-situated Theory in which the 'experimenter' somehow transcends the 'experimental' situation. ('Sartre overcame Althusser's Kantianism by...preserving the link

of knower and known, theory and practice'.⁶⁴) It does not entail, however, a return to the subjectivity which Althusser takes such pains to remove from the stage. For Sartre;

There are two ways to fall into idealism: The one consists of dissolving the real in subjectivity; the other in denying all real subjectivity in the interests of objectivity. The truth is that subjectivity is neither everything or nothing; it represents a moment in the objective process...⁶⁵.

It is at this moment that Sartre locates that critical experience which is the experience of the dialectical relation between the act of knowing and the object known. Laing aptly describes critical experience as the Ariadne's thread which runs, not from a subject as individual consciousness, but from the person's actions to the forms of human collectives (series, groups, etc.). The connection between critical experience and discourse is neatly presented by Gillan:

In choosing an action, the individual inserts himself into history, that is, into the field of past and present conditions and of future possibilities that are sustained by the material existence of human objects, the practico-inert. The individual is from that point on an objective being; in choosing he has objectified himself... . The concept of action, or praxis, can sustain the meaning of history in the Critique, because it provides a terrain in which the transition from individual action to collective action can be

made within the material conditions constituted by the practico-inert, [Conditions which include language.]... The contestation of the primacy of subjectivity in the formation of historical theory posed by Lévi-Strauss's Savage Mind and the writings of Michel Foucault and the Les Annales group in the name of the exposition of history has, then, a counterpart in Sartre's thought... The exteriority of language to consciousness is the acquisition of structural linguistics and structural anthropology: language is first of all a system independent of expression. In Michel Foucault's The Archaeology of Knowledge this exteriority is assumed in the concept of discourse... The subject is accorded a position within a discursive formation; he is given a site from which he speaks.⁶⁶

What is shared here is a focus on the exchange between subjectivity and the practico-inert, the realm of exteriority, of sites. While Foucault's 'archaeology' concentrates on locating and describing sites and positions within discourse, Sartre's 'anthropology' provides categories which come into play through and across these sites and positions as their 'substructural conditioning'.⁶⁷ In both instances a system of relations external to the subject catches up and disperses subjectivity into 'moments' of an objective process. The system, for Foucault, is that which defines the nature of the interposition of discourse (across which is the almost spectral shimmer of 'culture') between the subject and everything else. It is a matter, largely, of the systems of formation, the regularities, which reside in discourse itself.

For Sartre the system of relations is that which, in institutional society, transcribes itself by force on the surface of discourse (to borrow a formulation of Foucault's). It is towards the 'surface' of the concrete, of the actual sites and relations where discursive practices operate, that Sartre's categories in the Critique ascend. But where on this vertiginous slope of subjectivity perpetually reappearing in action in order to be eliminated, of collectives and apparatuses, is to be found sufficient stability (such as was provided by the idea of truth succinctly analysed by Reiss) to permit a tenable epistemological position? Where is the other discourse?

We would have to consider a dynamic circuit composed of the discourse at trial, the critical discourse in process, and the interactive operation itself, which relationship would be constantly evolving because each of the elements would constantly be acting upon all of the others.

This is simple to say, considerably less easy to do. The result of such interplay is likely to be unreadable, or merely anarchic. This other discourse would seek... to show that thought cannot merely fix information as knowledge but is necessarily a constant functioning of the operation of knowing...⁶⁸

This brings to mind Hofstadter's comment about the consequences of overriding seemingly natural and inevitable systems, particularly when they get tangled, (systems such as the discourse of truth,

although Hofstadter is referring at this point to the legal system):

Then a seeming anarchy takes over; but anarchy has its own kinds of rules, no less than does civilized society: it is just that they operate from the bottom up, not from the top down. A student of anarchy could try to discover rules according to which anarchic situations develop in time, and very likely there are some such rules.⁶⁹

In this sense Sartre is a student of the anarchy naturalized by 'civilized society'. Working painstakingly 'from the bottom up', he occasionally rushes breathtakingly along the Ariadne's thread through the generalised enterprises of persons, groups, classes (their believing, signifying, constructing, Intentional activity):

Within the unity of his own enterprise, each person surpasses the other and incorporates him as a means (and vice versa); each pair of unifying relations is in turn surpassed by the enterprise of a third. Thus at each level there are constituted hierarchies of enveloping and enveloped ends, where the former steal the signification from the latter and the latter aim at shattering the former. Each time that the enterprise of a man or a group of men becomes an object for other men who surpass it towards their ends and for the whole of society, this enterprise guards its finality as its real unity, and it becomes, for the very people who initiated it, an external object which tends to dominate them and to survive them.... Thus are constituted systems, apparatus, instruments.... Therefore, for a given society, the correct procedure will be to take into account both the living ends which correspond to the particular effort of a person, of a group, or of a class and also the impersonal finalities, the by-products of our activity which derive their

unity from it and which ultimately become the essential, imposing their structures and their laws on all our enterprises. The social field is full of acts with no author, of constructions without constructor.⁷⁰

So at every level we will find finalities which pass themselves off as essentialities. Within the discourse of truth essentialities of this kind will appear in both places, as essences abstractable from within the concrete and (within the discourse at trial this appears as 'or') as fixed categories applied to the concrete. Instead of the either/or choice and the potentially endless tangle (where there is no distinction between 'lower' and 'higher' levels) presented in A below, there must be something like the helix in B:

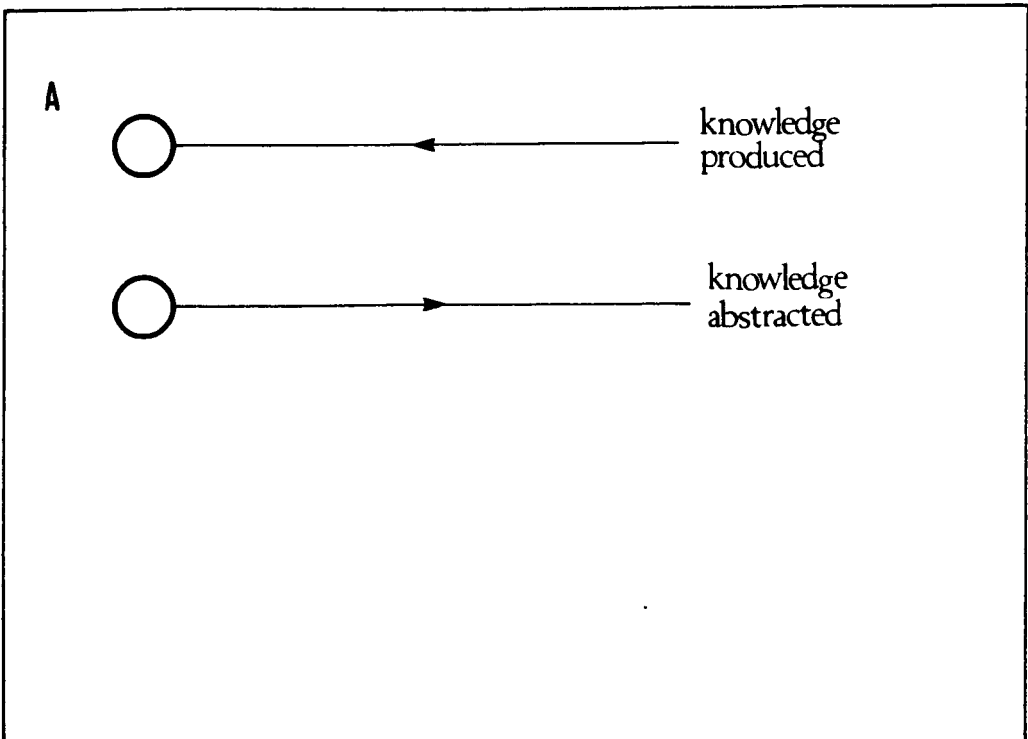

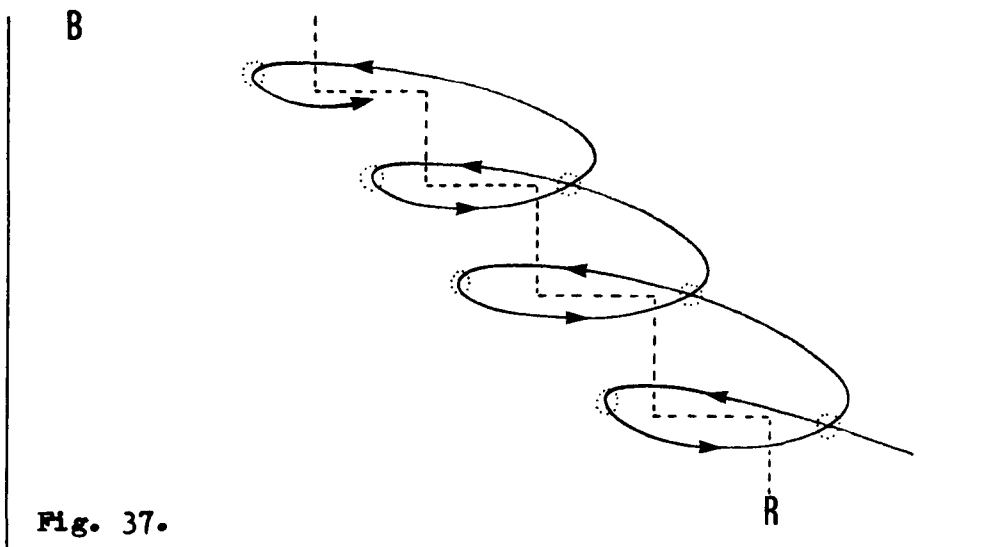

The upper strand of each loop in the helix represents the effect of the progressive moment of theoretical practice while the lower represents the effect of the regressive moment, the objects at each level being the essentialities which are deconstructed as the loop passes through them. Sartre's method is to move through the various levels of intelligibility on which these various fixtures may be found, in fact, to slip vertiginously.

Notice that the arrows still represent effects: the real 'movement' is not from the bottom up but of expression, back in the space of the connecting ergo, in the time of writing/reading the Critique for example. This is what R represents. The multistage loop, running from low levels to high levels (but it is on a high level that R begins, for example with 'our nearly

unanalyzable feelings of self'⁷¹) is largely a hypothetical extension; we may not be capable of taking it very far: Sartre actually does the method by concentrating on one or two loops, for instance as they pass through the object 'Flaubert', and Hazel Barnes has perfectly encapsulated the sense in which Sartre's writing foregrounds the 'interactive operation'⁷² without itself slipping into the totally anarchic: 'Is The Family Idiot a biography of Gustave Flaubert or a novel? Is it Jean-Paul Sartre's autobiography in disguise? Is it a book about literature? Is it a philosophical work? It has been called all of these.'⁷³ Here we have a description of a practice which refuses to repress the functioning of the evolving operation of knowing. This refusal is based on what Sartre calls 'the truth of micro-physics'. Indeed, of the consequences of a Sartrean mixing of subject and object for such a discourse there are what Hofstadter identifies as 'two major previews':

One was the revolution of quantum mechanics [referred to by Reiss⁷⁴], with its epistemological problems involving the interference of the observer with the observed. The other was the mixing of subject and object in metamathematics, beginning with Gödel's Theorem...⁷⁵

As Hofstadter's tour de force amidst these consequences opens up a field of daunting, if exhilarating, complexity, we might rely on him finally for a few practical guidelines.

Hofstadter advocates, 'understanding not just one level at a time, but the way in which one level mirrors its metalevel, and the consequences of this mirroring'.⁷⁶ He goes on:

Moreover, we will have to admit various types of 'causality': ways in which an event at one level of description can 'cause' events at other levels to happen. Sometimes event A will be said to 'cause' event B simply for the reason that the one is a translation, on another level of description, of the other. Sometimes 'cause' will have its usual meaning: physical causality. Both types of causality--and perhaps some more--will have to be admitted... .

We have already begun to operate in this way, with the shift from the level of events in a narrative structure to the levels of performance and supposition, and this will continue to be an important aspect of the present work, but more generally we need to shift levels at each point where an essentiality presents itself, in order to dissolve such effects; to dissolve the apparently solid features of an imaginary landscape and to reveal as historical sedimentations the apparently

universal structures which theory might deploy (GIIIs as 'myths'). This is a matter of finding the 'causes', on another level, of each essentiality constituted in the practico-inert as a counter-finality. As Sartre puts it, 'These objects are there before our eyes'.

CHAPTER 6

POLICING RELATIONS

6.1. Fantasies?

Questions, if not indeed dilemmas, of social control are raised persistently by American films dealing with crime and the police. Bronk's very name, for example, encapsulates the tensions; the half-tamed. Few films spend as much time as Electra Glide in Blue on routine traffic patrols for instance. Instead 'real' villains take up most of the screen detective's time and although they are not always as menacingly and unequivocally 'corrupt' as Cagney and Lacey's Nazi war criminal turned diamond thief and murderer, they are seldom less than threatening to the social fabric and are as often as not unmistakably 'sociopathic'. As a result almost any such film can appear to have its elements of 'social awareness', however ill-defined. Common sense suggests that at some level when a screen 'cop' cleans up the streets like his Western predecessor he is offering a palliative to

whatever real fears of social disintegration or victimisation may be prevalent in the audience. But where the palliative stops and the incitement to gun-law and the compulsory improvement of 'morals' begins is a thorny issue, not least because it involves how a film is read (constructed?) and, therefore, ultimately backtracks questioningly to the 'common sense' notion of a palliative.

When the lurid neon message 'Jesus Saves' is shot away in Dirty Harry are we meant to understand that a new and more practically effective Messiah is on his way? 'Dirty Harry Saves'? Or is the depiction of Harry's tactics to be read as an exposé of the harrying-vigilante fallacy within the 'law and order' demand? Or perhaps it is not a matter of what an audience is 'meant' to read (meant by whom?) but of what actual audiences do read in the film? Each of these possibilities deserves serious consideration, although the third would eventually necessitate research techniques outside the scope of the present study. What has been begun is a consideration of the first two possibilities in relation to the position of the audience in general, that is in relation to what it means to be an audience.

What is at issue, moreover, is not just the proffered image of law-enforcement and the possible relationship of the audience to it, but also a kind of 'total image' of society. If a certain cinematic coziness (which was never, of course, the whole story) has tended to give way (leaving plenty of traces, nonetheless, as in The Waltons)^{1*} to a world of seemingly random violence, paranoia and moral corruption ('from reverence to rape',² etc.) is this a brave confrontation with the way things are, or a way of making money from prurient audiences? Perhaps it is neither, of course. What seems undeniable is that, whatever it is, it often masquerades as 'true-to-life', as a 'social awareness', a 'gritty realism', a supposedly 'adult' (worldly, unshockable) image of the way things are.

Alan Lovell has neatly delineated the three principal strands which traverse Dirty Harry and constitute this kind of discourse:

The first emerges out of the work of writers like Ernest Hemingway, James M. Cain, Dashiell Hammett and Raymond Chandler: the so-called 'hard-boiled' school of writers. The second strand, the Gothic one, looks back to the sensational literary genres developed in the 19th century, especially the horror genre as epitomised by the stories of Edgar Allan Poe. The third, a journalistic / social conception, relates to a view of the state of American society in the 1960s as marked by the breakdown of law and order, a breakdown which is partially blamed on an unrealistic liberalism.³

* notes and references begin on p.738

Indeed, looking back, Dirty Harry would seem to have been something of a way-station through which these discursive strands passed to become firmly established on the American screen in the subsequent decade. But, the three principal strands having been identified, a certain temptation arises which needs perhaps to be resisted to a degree. The temptation is to work only 'inside' the film in order to find these strands in operation together, and the mechanisms of that operation. This 'explains' the film only insofar as a person's ancestry in the form of DNA strands determines his or her genetic makeup; the fact of ancestry being 'inside' the person does not exhaustively explain his or her position in personal and social relations today. So we are returned to the need for an explanation which is capable, not just of locating elements within the film, but of locating the film as a film, that is in relation to an audience.

This perspective reveals the necessity, also, of considering the affective dimensions of such a relationship; if cynicism, violence and corruption characterise 'the way things are', if the 'total image' projected by films such as Dirty Harry maps some supposedly recognisable 'outside' reality, then why should (does) an audience leave

that reality for the representations proffered by the screen's illusionism? What makes the screen more desirable? Clearly any simple notion of 'escapism', whatever that might mean, is inadequate to the success of The Exorcist,⁴ for example. In what sense could audiences be understood to have paid in excess of ninety million dollars⁵ (putting it just outside the top dozen box office draws in American cinema history and making it the most audience-successful horror film to date) in order to 'escape' for some two hours? On the other hand, what does quite unmistakably connect The Exorcist and the similarly successful Snow White⁶ is their provision of what might be loosely termed an emotional experience. Costa-Gavras has commented with considerable insight on the kind of double-bind which this emotional dimension can produce for an audience. Interviewed about his first American film, Missing,⁷ he points out that members of an audience who feel threatened by its criticism of the U.S. role in the Chilean coup tend, nevertheless, to respond to its human problems (engagingly enacted, due to particularly shrewd casting, by Sissy Spacek and Jack Lemmon):

Some people reject the whole movie, saying, 'It's not true'. This is not a superficial reaction, though, it is a politically profound one. People are somehow moved because it's a personal story, and the only way to get rid of that emotion is to reject the whole thing, to say, 'It's not true, it's a fake story, I was manipulated'. But you have to deal with that emotion...⁸

Locating a film involves paying due attention, not only to the obvious enough economic interests which maintain cinema, but to the emotional 'interests' which also maintain it. So the question of whether dominant cinema programmes its audiences with the standards, beliefs and conformities necessary to fit them comfortably into the social formation's pre-designated 'slots' (which include the position of consumer just as surely for cinema as for any other industry) is a question which must take into account the real emotional investment that an audience makes in a film. That investment and its vicissitudes make 'popularity' an elusive quality, and its pursuit a matter of considerable commercial risk. Sartre's progressive-regressive method enables us to avoid simply positing these emotional investments as a priori characteristics (essentialities) and instead to see them in a spiral structuration with the objects towards which they are directed, a spiral which renders the notion of escapism meaningless.

When semi-automatic machines were first introduced investigations showed that specialised women workers indulged in sexual fantasies as they worked.... But it was the machine in them which was dreaming of love: the kind of attention demanded by their work allowed them neither distraction (thinking of something else) nor total mental application (thinking would slow down their movements). The machine demands and creates in the worker an inverted semi-automatism which complements it: an explosive mixture of unconsciousness and vigilance. The mind is absorbed but not used; it is concentrated in lateral supervision; and the body functions 'mechanically' while yet remaining under surveillance. ...the minutes of false distraction have to be lived one by one; they must be lived without concentration, and there can be no attention to detail, or to systematic ideas; otherwise the lateral function of supervision would be impeded... .

In similar situations, men have less tendency to indulge in erotic fantasies; this is because they are the 'first sex', the active sex; if they were to think of 'taking' a woman, their work would suffer.... Naturally, rumination can have various aspects, and may attach itself to different objects.... Nevertheless, it is essential that the object of her daydreams should also be the subject, that there should always be adherences: if the object posits itself for itself (if the woman emerges from her daydream, and thinks about her husband or her lover), the work will stop or slow down.... The truth is that when the woman worker thinks she is escaping from herself, she is really finding an indirect way of making herself what she is... she tries to fix her mind within the limits allowed by the operation, by the objective task: she is the unwilling accomplice of employers who have⁹ determined norms and minimum output in advance.

If we consider, for a moment, the screen as a 'semi-automatic machine', running on inexorably but requiring the attention of a spectator, we can see something of the nature of the spiral in which the affective dimension of viewing is caught up; it is the machine in the spectator which is

'dreaming of love', and so on. The machine demands a certain kind of attention. Both thinking about something other than what appears on the screen and thinking too closely ('systematic ideas') about something which appears there can result in the spectator being left behind by the film. The spectator clearly cannot afford to 'slow down' in this way; the machine dictates the pace. There is, therefore, on the spectator's part precisely an 'inverted semi-automatism' which complements the operation of the screen-machine. We have already begun to outline this function in terms of the relationship between screen events and the suppositional patterns which mediate the spectator's absorption. What Sartre's insights suggest is that, within the emotional investments which maintain the operation, these patterns do not openly and deliberately posit themselves for themselves. There is an 'adherence' of object and subject; in short, an abandonment within the allowed limits, which makes of the spectator an accomplice (unwilling in the sense that ~~s~~he thinks ~~s~~he is 'escaping') of those who ultimately profit by the machine's continued operation.

The spectator as 'mixture of unconsciousness and vigilance' monitors the screen in much the same way as Sartre's worker supervises her machine;

there is no need of 'total mental application': indeed dominant cinema encourages an effortless absorption which both engages the lateral supervision required to sit still and watch the screen and provides the 'fantasies' which can, in large measure, be 'lived without concentration', the daydream of sexual abandonment perhaps serving metaphorically to indicate something of the nature of the emotional investments and pleasures involved. Paradoxically, therefore, the very act of watching a screen brings the spectator's body itself under a kind of 'surveillance'. The screen superintends the spectator, subdued with his/her own collusion, 'fixed' within the limits allowed and, when the screen is functioning at peak efficiency, no less than paralysed with emotion. This is the audience's transfixion in seriality.

What remains central throughout is that there is a content to the 'day-dreams', the 'fantasies'. The worker's situation prescribes certain limits to that content; only certain content works with the situation (e.g. the fantasy of abandonment). Similarly, the screen cannot be thought of as entirely reducing the experience to the basic fact of the look, as in hypnotism: the audience's emotional investment depends, no less than the fantasy of the worker, on what one 'sees'

within the given limits. A degree of unpredictability arises, therefore, to explain the elusiveness of commercial success and how particular audiences relate to particular films.

6.2 Police stories

It is easy to dismiss the bulk of American television fiction as being somehow too 'light' for serious consideration, either on the grounds of 'meaning' or construction. Yet in the case of construction, there have evolved elaborate and sophisticated ways of securing a position from which the material, so to speak, wants to be understood, and these ways certainly require serious consideration if the functioning and popularity of such material is to be properly examined.

One of the simplest ways in which a particular kind of understanding is invited may appear at first to be little more than an irritating convention; that of leading into an episode via a trailer of six or so supposedly key moments edited into a sequence of less than half a minute's duration. These introductions do, however, serve to indicate what is seen as the main selling point of the particular film or episode. They also serve to produce, prematurely, a kind of 'synthetic' initiating event, which is not properly an event at all but an accumulation of pointers to that event, which allow ei itself to be located farther into the film; a kind of carefully controlled pre-ignition.

In The Jar, a film in the Police Story series,¹⁰ the trailer shows a young police detective (his occupation is taken for granted given the nature of the series) complaining to his wife (again a fairly routine supposition of identity); 'Everybody in the neighbourhood wanted to be my pal before this thing happened'. So a (pre-)supposition is immediately generated, that when it comes, ei ('this thing') will bring the police officer and the community into an antagonistic relationship. In fact we then see two detectives in the trailer, accused of having 'wasted the wrong man'. When the film 'itself' gets under way the audience has been primed with a supposition against which they may be expected to check subsequent information.

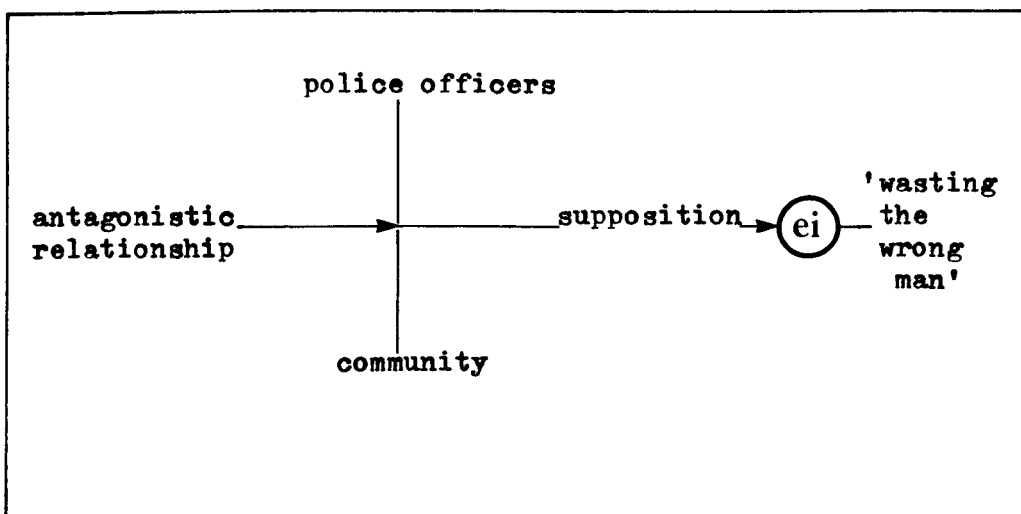

Fig. 38.

As the plot develops particular elements are clearly signalled as being intended to cluster along this initial trajectory. Trying to trace the young black perpetrator of a liquor-store robbery and homicide, the two detectives, Hagen and Triplett, are confronted by his mother who is sceptical about their intentions: 'Big shot cop! You come out here, waving them guns around. You wasn't looking to do my son no favour. You was looking to shoot him down. You think I'm a fool?' Then, assigned to another case when the liquor-store investigation loses momentum, the two apprehend an armed suspect in a smoothly efficient, text-book operation of the kind audiences must be thoroughly familiar with, so often is it repeated: the door kicked down, the guns swung in with that distinctive two-handed posture, the suspect frozen in the instant when the choice between surrendering and reaching for his gun gives the moment its charge of excitement. As they disarm the man, detective Hagen taunts, 'You guys who play with guns make me sick'. The suspect, rather less than over-awed by the whole affair, observes astutely, 'Yeah? I saw the way you looked when you drew down on me. You liked it man!'

With a fresh lead on their other investigation Hagen and Triplett enter a suburban apartment in a dawn raid to make another arrest but this time when they 'draw down' Hagen's gun goes off in a scuffle with the suspect whom they have unceremoniously awakened, and Triplett fires in what appears to be a reflex action at the sound of the other gun. The young black man is killed outright: ei. A case of mistaken identity, he was entirely innocent.

To reinforce the location of ei in its key position in relation to the supposition of an antagonistic relationship between police and community, when Hagen and Triplett return to the scene of the shooting they are surrounded by an angry group of residents who clearly feel that an innocent man has been murdered. This sequence recurs in exactly the same form as a piece of TV news film as the case against the two detectives begins to develop.

The film conjures up, therefore, the spectre that (as already suggested) haunts all representations of the police; the failure to identify as deviant, as 'others', those against whom the routine violence of the police is directed. The innocent man who has only an

instant of life on the screen before being 'wasted' could have been anyone, and in relation to that 'anyone' an audience may find itself inevitably implicated and disturbed.

After testifying before a grand jury, Hagen and Triplett encounter the woman whose son they had been looking for in the first place (they never do find him). As a swarm of reporters engulfs them, she announces, 'You in real trouble now! You said you would shoot my Oscar down in the street like a dog, but you killed somebody else's son instead'. So is the film also in real trouble, having positioned its audience and the police of its Police Story in an apparently antagonistic relationship? How does the film deal with the possibilities which arise out of the protestors' sign 'Killer Cops', and which it engages almost playfully, secure in the knowledge that it can successfully deflect the 'trouble'? 'Killer Cops' is a generalisable accusation with an epigrammatic anti-establishment thrust and, after all, there is no star here like Eastwood as a site in the text where contradictions can be contained (if that is how the star works). Indeed this engagement of a general antagonism is why the superiors of the two detectives consider them 'hot': they have to be kept 'on ice' until the police

force as a whole is no longer embarrassed by the affair. The risk is basically that the community will view the violence (in the broadest sense) of routine policing as directed against it, rather than on its behalf against 'others', whoever they might be, and it is here that the audience's emotional investments in the Police Story become available for disturbance. The Jar is, however, finally not a disturbing film. Indeed in relation to its supposed audiences it treads very carefully. Certainly it allows an element of rashness in its two main protagonists, a tendency to seek confrontation, but this could be interpreted as over-enthusiasm rather than recklessness. So when the innocent man panics and grabs Hagen's gun, there is the sense that the resulting death was avoidable, that the affair could have been handled less bullishly, but also that it was 'one of those things', an unfortunate accident given the circumstances (boys-will-be-boys?). But this is hardly enough to deflect the potential for disturbance, and the film knows that it is not enough; in fact the film ensures that it is not enough by playing along with the 'big-shot cop' accusation. ('You liked it!' and so on). Instead of foreclosing on that potential and, therefore, appearing to be just another story of 'macho-cops'

laying down the (gun-) law, The Jar admits the potential for disturbance and to that extent might appear to be 'progressive'. What it does, however, is to control the disturbance in a very careful way.

Around the not unusual adolescent quality of the 'buddy' relationship (Alias Smith and Jones, Starsky and Hutch, etc.¹¹), The Jar erects a constraining 'Oedipal' structure. 'Best partner I ever had', Triplett tells his wife in bed, referring to Hagen, to which she jokingly reacts with indignation and he corrects it to 'the second best I've ever had'. Searching for a 'secret room' at the back of a garden shed (traces of puberulent sexuality about the very idea), Hagen and Triplett actually begin to look like two boys playing cops and robbers; 'Hey, look at this!' and they scramble on hands and knees through a hole and out into a play-yard where Triplett jumps up on a swing in time to watch a train go past. As if to fix this reading, the camera follows the gaze of the mother (Oscar's mother), panning from her along her eye-line to Hagen and Triplett as they scramble around. Back at the squad room, their lieutenant, Terranova, calls for them and Triplett grumbles like a sullen boy, 'That guy's

got radar. Every time we come through the door he's calling us'. Chastised by a deputy district-attorney and later by a judge, they wait mutely, Triplett with bowed head, and take the scoldings like two errant schoolboys; 'Well, you've both told me what happened and, to be perfectly honest, I just can't believe either one of you'. As the pressure mounts, they look increasingly to Terranova for paternal support. 'I never thought I'd say this', confesses Triplett, with an adolescent's ambivalent resentment and respect towards his father, 'But I'm glad Terranova's here. He's the only one that stuck by us through this whole thing'. Terranova plays the father (a particular kind of father) to perfection. 'The two of you are going to make an old man of me!', he tells his wayward 'sons', and again, 'The two of you are going to be the death of me yet!', with almost clichéd exasperation. What then is the nature of the pressure on Hagen and Triplett, the pressure which sends them looking for a 'father'?

When Hagen's young daughter gets beaten by other schoolchildren, we are offered a subjective point of view and see them closing in with clenched fists. The sympathy which this elicits for the child is appropriated by the

father who becomes, himself, a child in need of the kind of protection he gives his daughter. This is even more explicit in Triplet's case. 'They read the papers, they see the news on television, and they're so cruel', says Joyce Triplet about her daughter's schoolfriends, but it could equally apply to, and slides into, the world in which Hagen and Triplet have found themselves, tormented by obscene 'phone calls and 'presents' (such as a dummy bomb), and by the angry protestors; fodder for the television news which completes the vicious circle. The most immediate reaction of the two detectives is 'typically' schoolboyish; they get into a brawl in a public lavatory.

Put 'on ice' by the police department, Hagen and Triplet are forced into a third position which disrupts the diadic structure of the basic antagonistic relationship.

Fig. 39.

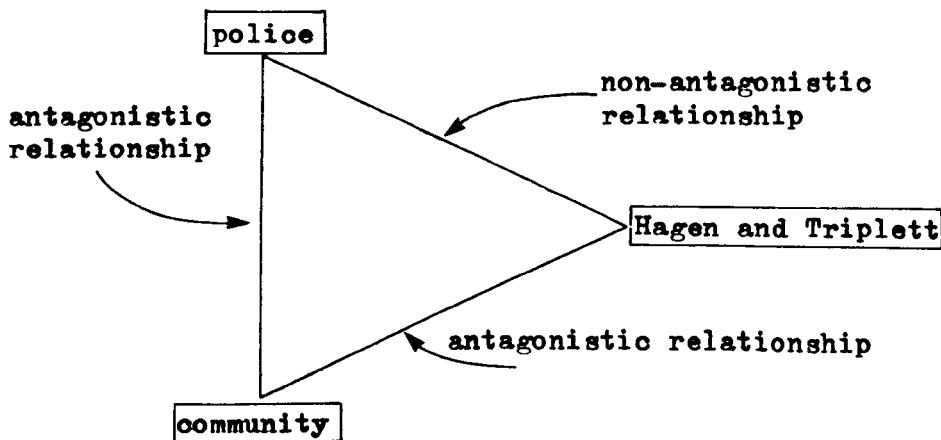

Allowed to keep their guns and badges but with the threat of suspension still hanging over their heads they are, as far as possible, disowned (including physical distancing: they are sent to the out-of-the-way harbour precinct) by the police establishment, without the creation of an openly antagonistic relationship. They are also disowned, but more obviously, by their community, as Triplett discovers from his wife:

'You're telling me that none of the neighbours will talk to you, that you've got to take the baby to a strange neighbourhood to walk it, and you're telling me not to get upset! What happened to all of our good friends? What happened to them? Everybody in the neighbourhood wanted to be my pal before this thing happened'.

Considerably distraught, Triplett goes out into the dark, suburban street and as faces peer from behind curtains, lights go on, and dogs start barking, he shouts to his neighbours:

'Where is everybody? Where are all my good friends? Why don't you come on out? I just want to talk to you. I just want to thank all you good people for the kindness you've shown my wife, my baby. Come on out! What are you afraid of? I won't hurt you.'

Evidencing what would be welcome depth of characterisation, except that it is turned to a very particular purpose here, Triplett is constructed

as a child/victim as he sits weeping on the kerb, marking a key point in the film's manipulation of the categories victim/victimiser.

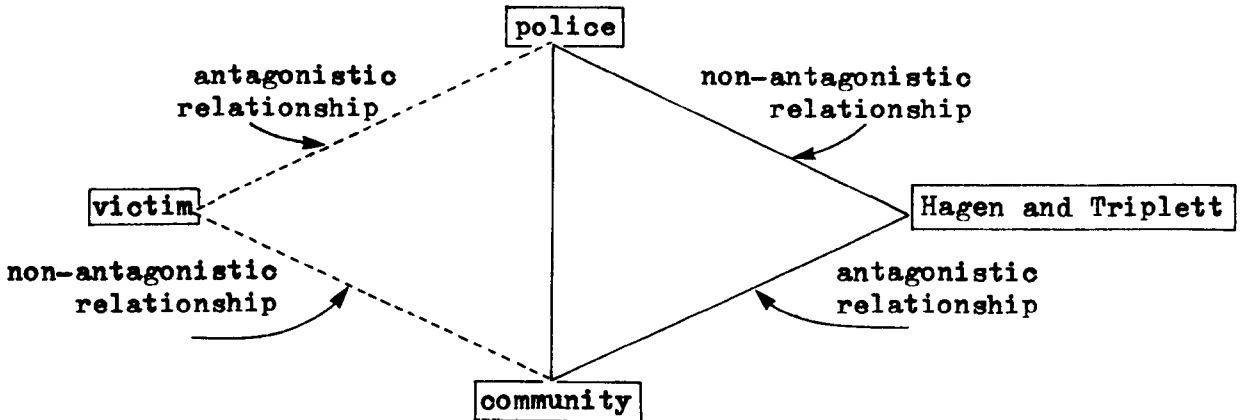

Fig. 40.

To be recovered from the disturbing role of victimisers, Hagen and Triplett must supplant the victim in some way. The dotted lines in the diagram represent the elements which, to this end, the film works to subdue within itself, firstly by establishing an antagonistic relationship between the victim and the community which is 'forgotten' (but not, perhaps, by the audience) when he dies. Neighbours have been complaining about his noise and other nuisances ('It's about time!' is the building superintendant's reaction when Hagen and Triplett first arrive) but rally indignantly when

he is killed, and rightly so of course but, nevertheless, the film has undermined the status of this non-antagonistic relationship, beginning the erasure of the left side of the diagram in order to re-define the position of Hagen and Triplett. The erasure can only be complete, however, if the victim can be made to disappear and the film, remarkably, achieves just this.

The first move in this strategy is the re-definition of the apex of the diagram and the relationship of Hagen and Triplett to it. Terranova brings in attorney George Fanning ('Dan Terranova's an old pal of mine') who immediately establishes an avuncular relationship with Terranova's 'boys', which adds to the 'family' group in which Hagen and Triplett find support. Fanning is worldly-wise as befits an uncle and instructs his charges in the nature of the opposition; 'There's a gutless DA running for his life, a hot story that's going to sell plenty of newspapers, and there's a guy named Turner who wants to turn the shooting into a great big racial incident so he can walk into the state assembly across your backs'. Fanning, in short, transfers the source of the pressure on Hagen and Triplett from the community on to institutional interests which introduce a new term into the network of relationships constructed by the film.

At this point another two significant changes are made. The community is re-constructed as an audience, indeed as the audience of this film. Instead of seeing more angry protestors on news film, the audience is addressed by a TV presenter who speaks directly into camera (a 'TV camera' and the camera which films The Jar, simultaneously) and delivers a complete news report, which effectively superimposes the audience of the fiction on the fictional audience/community. And the 'police' as a term in the pattern of relationships established by the film, is shifted back onto the group centred on Hagen and Triplett while the apex of the film's internal 'diagram' is re-located to other institutions, specifically to areas where political self-interest is detectable. When Hagen and Triplett attempt to continue with their police duties, and here we see them dealing with 'real' villains such as snipers and a crazed Vietnam veteran (i.e. 'deviants' who have been established through repetition in fiction; Targets, Taxi Driver, etc), they are obstructed by the institutional pressures which Fanning has identified. Specifically they are obstructed by another father-figure, located near the centre of the power which has trapped the

two detectives in what Hagen refers to as 'the jar', where they are like imprisoned spiders (a metaphor which Hagen links explicitly to schoolboyish petty cruelty, reinforcing once again that frame of reference around the construction of these two characters).

The malevolent 'father' is deputy chief Burns, whom Hagen and Triplett only meet towards the end of the film. Called to his office in order to be told the restrictions under which, according to the will of 'upstairs', they are to carry out their duties (which come down to an injunction on using their guns), Hagen and Triplett sit hunched at either side of a long, heavy table at the end of which is Burns, the table itself being clearly offered by a low camera angle from in front of Burns as symbolic of abstract male power. The film finally, therefore, lays its 'Oedipal' cards on the table. The constant threat to Hagen and Triplett is the loss of their guns and badges, a threat of 'castration' which the film traces back to Burns while deploying, simultaneously, a benevolent 'father' in Terranova, who is more like one of the boys. We even see Triplett sporting his big badge in the middle of his belt in forced phallic symbolism, but then having it all undermined when he insists to a colleague, 'I

still wear a gun and a badge' only to hear that he cannot do anything with them; 'You do pal, but you just wear them. You can put them on and you can take them off'. But Terranova rescues his boys from this anxiety, defusing their final confrontation with Burns by overseeing (literally; he watches from a raised observation window) a second autopsy on the exhumed body of the victim. Afterwards, when the group gathers (Terranova, Fanning, Hagen, Triplett), they are told, 'There's not a piece of the man left bigger than a postage stamp'. Hagen and Triplett have been absolved (by forensic evidence indicating a struggle rather than an execution) and the victim has entirely vanished. Despite the new evidence, however, they still have to go to trial as an exercise in political face-saving by the various interested parties 'upstairs'.

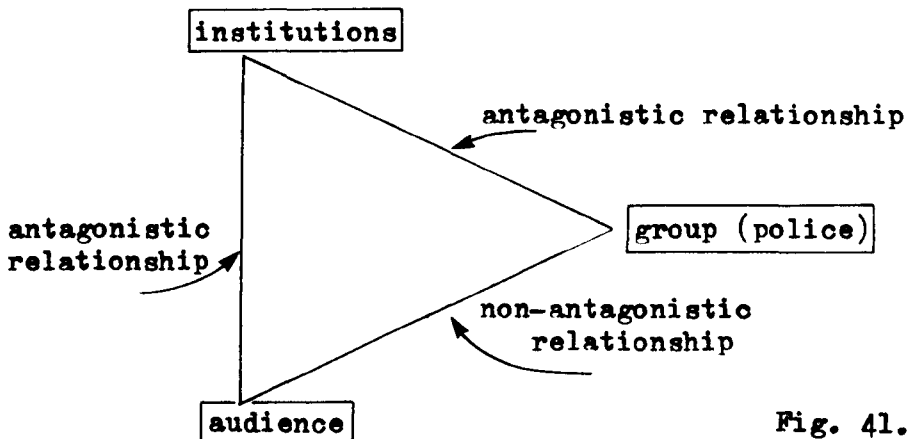

Fig. 41.

Acquitted but sent back to the harbour by Burns with the restrictive guidelines about the use of their guns still in effect, the two detectives grin at each other in determination to fight back, to make themselves a nuisance, to disrupt the institutional machinery which they now view as a hindrance to real police work, and which is the anonymous source of Burns' authority and power. In the end, for Hagen and Triplett the final encounter with Burns is not the 'Oedipal' climax of, say, Cutter and Bone.¹² Terranova has reprieved the Father's role and Hagen and Triplett have been educated into a superficially antagonistic relationship with the power of institutions, which is a basic credential for all cadet Dirty Harrys.

Another police story: a long lens piles the crowd of interweaving pedestrians on the sidewalk into a softly focussed mass of shapes and colours. The rapid rhythm of the soundtrack with its thinly vibrating whine against insistent percussion is picked up by two running men who elbow their way through the undifferentiated mass of others. Then, for little more than a second, there is a head and shoulders shot of a uniformed policeman, his look aimed over the look of the camera/audience, in the opposite direction, clearly

isolating the running men in the crowd. Having seen, he pursues. The two men (a and e for convenience) run between two parallel rows of public benches given a convergent, tunnelled appearance by a wide-angle lens:

Fig. 42.

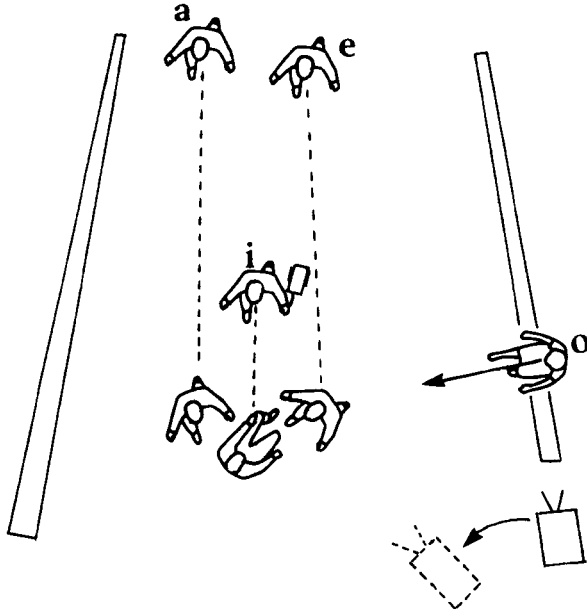

They run towards an old Jewish man (i) pulling a cart-load of papers. On a bench directly before the camera/audience is a young woman (o) watching some pigeons feeding. As the old Jew comes level with the woman the two men catch up with him and all three are caught on the woman's eye-line, at which point the camera pans along that line to centre on the three figures. The camera maintains its position on the bench with the other onlookers, catching the three figures in a triangle with the look of the young woman.

As a struggle develops between the Jew and the two men the camera cuts to a closer position but still on a line which parallels the line of onlookers on the other side. As one of the men draws a gun on the now prostrate Jew the camera establishes another triangle, looking up from ground level at the gunman as he braces himself to fire:

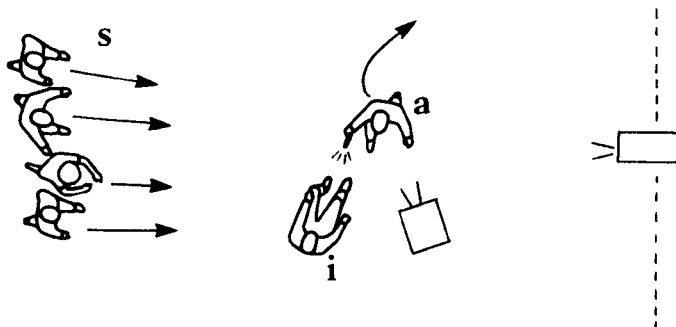

Fig. 43.

The sky glows harshly between the office blocks behind the gunman. As the two gunmen leave the Jew dying on the street, people (s) run out from the sidewalk to crowd around him, much as the camera has just done.

Later as Kojak¹³ arrives on the scene (in an episode entitled Wall St. Gunslinger), car siren wailing, the camera/audience stares up directly into the glare of light and pans slowly down the skyscrapers on to the old face of the dead Jew, then pulls focus on to the crowd of

bystanders, now swollen to hundreds. Kojak emerges in front of the crowd and the camera/audience obediently follows him back and forth around the scene of the crime as he begins his investigation. A witness is brought to him:

Kojak: What's your name young lady?

Woman: Fern. Fern of the Wind.

K: Lovely.

W: I was sitting over there where it happened but I didn't see the fight or the death.

K: A man was being beat up here, and you were sitting over there--and you didn't see anything?

W: I lost my job. I was meditating.

K: Oh, I'm sorry. But were your eyes open or were your eyes closed?

W: Open.

K: Well, no matter who your guru is, you must have been looking at something. What was it?

W: A couple of pigeons making love. I was thinking, how could they be so happy and me so miserable?

What happens in this sequence is the establishment of a triangular relationship in which the look of the camera/audience is matched by the look of a victimised, powerless subject; essentially the look of the woman but also momentarily the look of the old Jew in the instant of death. Kojak's function is to supplant the villains in the apical position and harness the otherwise powerless and

mis-directed look to his own, strengthening that momentary look of the policeman which has already cut across the camera's/audience's involvement in the action.

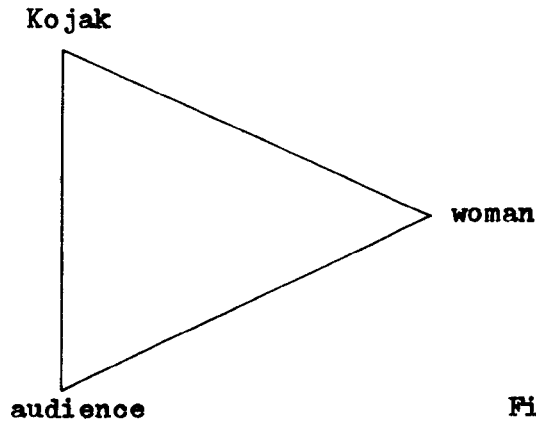
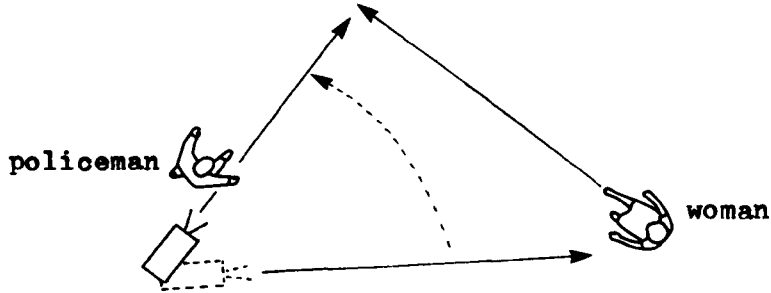

Fig. 44.

In itself this is a not unexpected strategy but the particular interest of this example is that it deploys another triangle which complicates matters intriguingly. Again a woman's look is the fulcrum around which the pattern initially turns. This woman is seen on only three occasions. The first is when she enters an expensive restaurant, scans the tables and obviously recognises someone. The camera pans to follow her look, as she moves across the floor, and the frame settles on two men, one of whom she greets warmly. In the same shot the camera pans a little more and pulls focus to reveal in the foreground a watching detective,

one of Kojak's team. Again we have the establishment of a triangle but in this case the look of the camera/audience is identified with that of the policeman.

Fig. 45.



The apical position here is initially filled by the woman's friend Lenny, a young high-powered entrepreneur (Kojak calls him the 'whizz-kid with the jets and the sheiks and the see-no-evil attitude'). The plot develops around Lenny's attempt to make a deal with a rich Arab who is also the potential victim of an elaborate 'sting' by the mafia boss behind the two gunmen (who killed the old Jew in order to retrieve stolen stocks which they had previously hidden in his cart and which the arch-villain intends to sell to the Arab). So just as Kojak forces himself on the first apical position, here the mafia boss Paulus (Lenny calls him one of the 'wise-guys') intends to force himself on the position occupied by Lenny.

The second time the woman is seen the visual organisation of the scene hinges explicitly on the look of the policeman, on this occasion across a bar-room and directly into the camera which pulls back to reveal the actual objects of his gaze; Lenny, the sheik and the woman, now named as Felicity. She is young, extremely attractive, expensively but tastefully dressed and showing enough of her delicately arranged legs as she sits on a bar stool to exude a confident sexuality (as constructed in this kind of discourse) which contrasts sharply with the tense uncertainty of Fern in the earlier scene. Called away on business, Lenny entrusts the sheik to Felicity's care.

Felicity's final appearance is the most telling. As Paulus is about to operate his 'sting' (using a rigged computer network to authenticate the stocks) his assistant takes a 'phone call. On the other end of the line we see, in a single waist-shot, Felicity in bed amidst expensive sheets and background decor. They discuss her role in bringing the sheik to Paulus, and her payment: clearly she is an expensive call-girl who has deceived Lenny. Interestingly this is a secret, yet again unveiled for the audience in the zone of sexuality, which is not discovered by

Kojak, who simply foils Paulus' plan in a ritual shoot-out and recovers the apical position which the villain would have usurped, thus 'keeping America safe for capitalism' as Kojak says, only half jokingly. Presumably Felicity's position remains unchanged, the only loose end which Kojak's resolution leaves untied. Such a 'problematization' of active female sexuality is common in this kind of material, occurring frequently around the roles of prostitute and/or the 'femme fatale' inherited from the noir tradition. But it can also be detected at work in some less obvious cases.

From the Wall St. Gunslinger to the Runway Cowboy: another triangle ('You mean all three of them are hooked up together?' as Baretta¹⁴ says), this time relating a judge, who happens to be a woman, the stock villain Danzio who is basically another Paulus (although in this case more willing to come down from his penthouse and do his own dirty work) and a suave young gigolo who works the airport lounges. Up on serious charges before the judge, Danzio uses the gigolo to blackmail her into leniency. The gigolo, however, develops a seemingly genuine affection for the judge, thus complicating the essentially

straightforward plot. It is into this area of complication that detective Tony Baretta is drawn, as it was this judge who rescued him from the streets as a child: 'I believe in fairy-tales. Like once upon a time there was a beautiful lady judge and she looked down on this little grumpy kid and he looked up at her and she could have thrown him in the manure pile with the rest of them but she took the time to put him together and make him whole again and it had a happy ending'. The 'manure-pile' is a familiar aspect of the cynical world-view projected by the series as a whole, the city streets full of it as far as Baretta can see, and the only escape being within oneself, in being 'whole' and in the advice of Rooster, the black pimp, 'Don't let it get to you man!'.

Baretta simplifies the situation by removing both Danzio and the gigolo. He tells the latter, 'I loved her long before you ever knew her ', the difference being that the relationship between Baretta and the judge is asexual (his respectful 'Your honour' insists on this fact and she is, moreover, quite clearly a mother-figure) whereas in the case of the judge and the gigolo there are incriminating photographs, the precise

nature of which is never known (Baretta burns them, almost ritually). If he can return himself to the position occupied by the gigolo in relation to the judge, the position of the younger man who loves her and on whom she can lean, Baretta can simultaneously release the judge from the power exerted by Danzio. Thus:

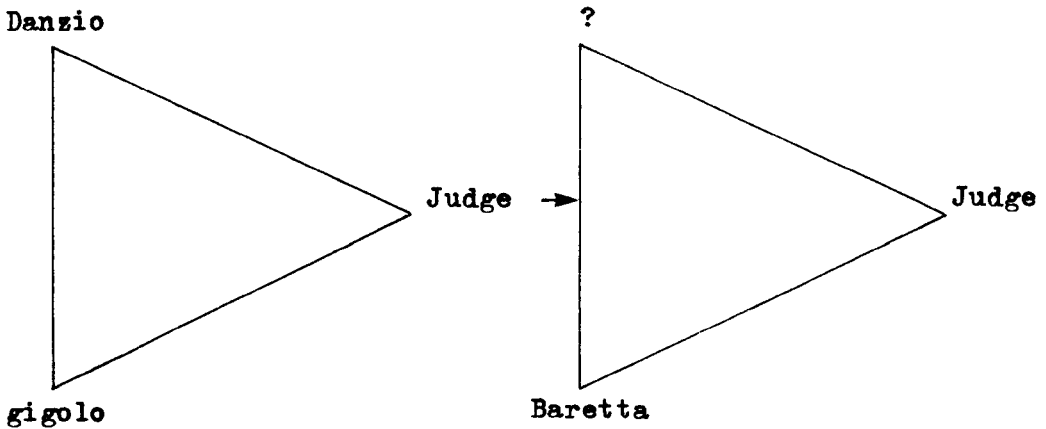

Fig. 46.

'We need you', Baretta tells the judge finally, when she is thinking of resigning from the bench. The 'we' covers a superimposition of law enforcement on a family structure. Tony is the policeman talking to the judge, but also the 'little kid' talking to his 'mother'. At the beginning we see the judge with her husband; they are clearly affectionate but the implication throughout her affair with the gigolo is that there is no sexual satisfaction for her within the family.

Baretta even mentions that he had once considered dating her daughter but had thought better of it: it is as if there were something vaguely incestuous involved. So the family structure in which Baretta finds his place, and into the preservation of which he collapses his role as law-enforcer, is actively desexualised. The gigolo and all that he represents (offers?) have to be removed. Indeed as Baretta smashes up the gigolo's flashy car he tells him, 'Pretty soon there ain't going to be nothin' left of this car and there ain't going to be nothin' left of you!'.

In a triptych of early scenes we see Danzio planning 'to call in that marker' (that is to enlist the gigolo against the judge), the judge's husband leaving on a business trip (and reminding his wife of their grandson's birthday), and a tryst between the judge and the gigolo; the plotting making it clear that the position of power usurped by Danzio, with the gigolo's ambivalent assistance, is rightfully that of the father. Although we do not actually see the return of the father, Baretta the dutiful 'son' has re-secured his position for that return, and he has done it essentially by driving out sexuality in the form of the gigolo (and his photographs with their secret).

In A Question of Honor¹⁵ ei is lodged in another opening triptych of scenes: the first presents the event proper, a police raid on a heroin factory in the Italian countryside, the second is set in the U.S. Department of Justice, Washington D.C., and the third in the U.S. Courthouse, Foley Square, New York, these two American locations being identified in superimposed titles. Also identified in this way are two men, Frederick Walker (Robert Vaughn¹⁶) Deputy Director, Bureau of Narcotics at the Department of Justice, and Paul Martelli, Assistant U.S. Attorney at the Courthouse. The three scenes are carefully interconnected: an important dealer caught in the Italian police raid asks his captors why their 'arrangement' has changed (indicating of course a network of corruption) and is simply told, 'There are Americans involved'. The buyer, Carlo Danzie, is then offered a deal by one of these mysterious Americans; 'We want him to work for us'. It is Danzie's acceptance of the deal that Walker at the Justice Department calls Martelli about; 'We've got the perfect guy for you. Nobody knows him in this country... I don't have to tell you the people down here are in a hurry for results. They want that city government in New York dirtied up in time for the May primary'.

The 'us' for whom Danzie will be working is thus a matter for more speculation than might at first have been anticipated. There is no monolithic law-enforcement machine here, no idealistic notion that everyone carrying a badge or a brief is on the same side. This is pointed up when Martelli describes the pending operation to a detective who, having got his 'hand caught in the cookie-jar', is now working clandestinely for Martelli and Walker. He is told to set up the arrest of Danzie when he arrives in the country carrying drug samples and his detention in the City Jail where they can then 'find out who he can buy: corrections officers, DA's men, judges, the whole thing top to bottom'. In a news broadcast on the television set in Martelli's office we hear of his role spearheading a drive to uncover corruption extending from police officers on the street to the 'upper reaches of the police department and the city government itself'.

In this instance, therefore, ei is a particularly complex piece of the machine, rendering problematic the relationship between guilt and innocence and demonstrating a particularly partisan side (Walker's 'people') to this kind of justice. The beginnings of a specific major

supposition do, nonetheless, emerge from the triptych of scenes. A chain of connections is established, running from Walker in the Justice Department (and the 'people' behind him) through Martelli to the detective, Marlowe (ironically) who has been forced to work for them, and from him down to the police officers on the street. Martelli tells Marlowe to use one of these in order to have Danzie where they want him. So the supposition is that at some point the machinations will converge on one of these ordinary policemen.

Indeed, in the next scene Marlowe, with a hidden tape recorder running, gives another detective the 'tip' about Danzie's arrival. This detective, Kirkorian, is both a pawn in a game of which he is entirely unaware and a potential target in the drive to uncover (and encourage in order to uncover) corruption in the police force for murky political ends. What is created here is a context around the conventional detective story with its crime/disruption- resolution type of structure, a context in which the conventional notions of law and order and justice which tend to accrete to this structure are rendered extremely ambiguous. Any policeman could be this kind of pawn. This is the repressed context in material such as Kojak

where guilt and innocence are neat categories, their boundary patrolled by the policeman who is a controller rather than the controlled. It is his adversaries who are the pawns of powerful men. It is the street criminal who may be programmed from elsewhere. But the street 'cop'...?

As if to emphasise the arbitrariness of the convergence of these various plot developments on one familiar figure, the police detective with a job to do, the film has the detective in question pass the 'tip' on (against Walker's expectations) to a friend who proves to be the central character in the narrative, detective Joe DeFalco (Ben Gazzara).

Joe first appears at dinner in his mother's house, the ritual gathering for a large Italian family. Joe's wife Jeannie and their two children are there, among other relatives. There are jokes with his brothers, some encouragement for his son who is despondent over his basketball performance, medicine for Joe to administer to his frail but energetic mother; in all Joe is constructed as other than the conventional loner-cop. This is an unremarkable Italian family in which he fits well. There is not the lost family of Harry Callahan or Bronk. There is not the artificial family of Ironside. There is not the 'buddy'

family of McMillan and Wife or Hart to Hart¹⁷
(not strictly a police series, Hart being a
wealthy industrialist whose hobby is detection!)
or of Starsky and Hutch for that matter. When
Joe is called away from the meal to follow the
'tip' which Walker has planted, it is entirely
clear that he has a genuine family life to be
called away from and it seems that he cannot be
fully understood in isolation from it, unlike
Kojak, for example, who is allowed no existence
outside his police role (the closest he gets
being as a part-time teacher of criminology in
early episodes, with a black book full of female
students' numbers).

Joe proceeds to arrest Danzie and
consequently the Italian is not put in the City
Jail where Walker wanted to use him, but is held
in Joe's precinct. When the American Interpol
officer who approached Danzie in Italy turns up to
press for Danzie's release from there Joe shrugs
off any suggestion that there could be something
more important at stake than the necessities of
the clear-cut job which he understands his role
to be. However Walker and Martelli decide to trap
Joe in such a position that he will be forced to
work for them, incriminating other officers and
city officials. They decide, in other words, that

as Joe has thwarted their plans for Danzie they will use him instead. The major supposition tends, therefore, to shift between the possibility that Joe will succumb to these plans and, on the other hand, his successful resistance to them. After Joe has entered the affair through his chance contact with Danzie, the choice is basically between two potential centres of control over the narrative; Walker and Joe.

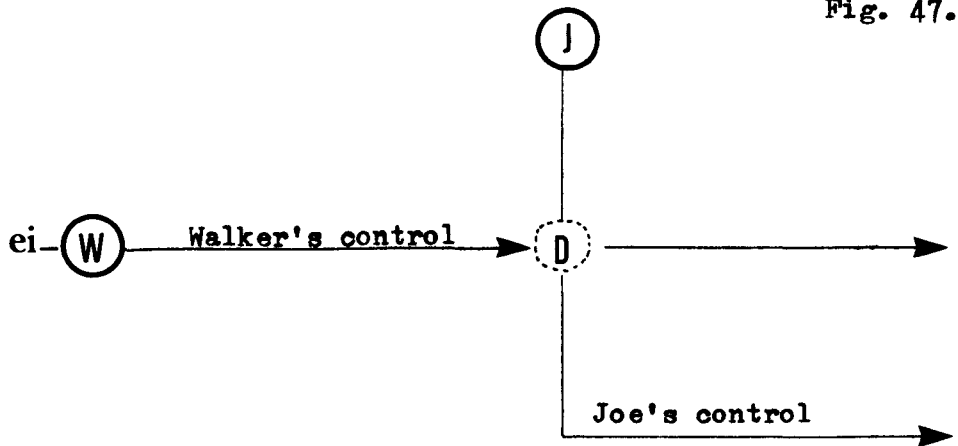

Danzie becomes a mobile piece in the game, shifting to and fro between Walker's trajectory and Joe's, each carrying its own suppositions.

Importantly though, Joe has a possible fall-back position, established from his first appearance; having a large and supportive family (but not a father, crucially for Joe's subsequent behaviour) Joe would seem to be released from the need to define himself solely in terms of his role as a

policeman. If he loses control there, if his definition of his role should become untenable under Walker's pressure ('We'll see how tough your boy DeFalco is') he should still have an available identity within the family as the film constructs it.

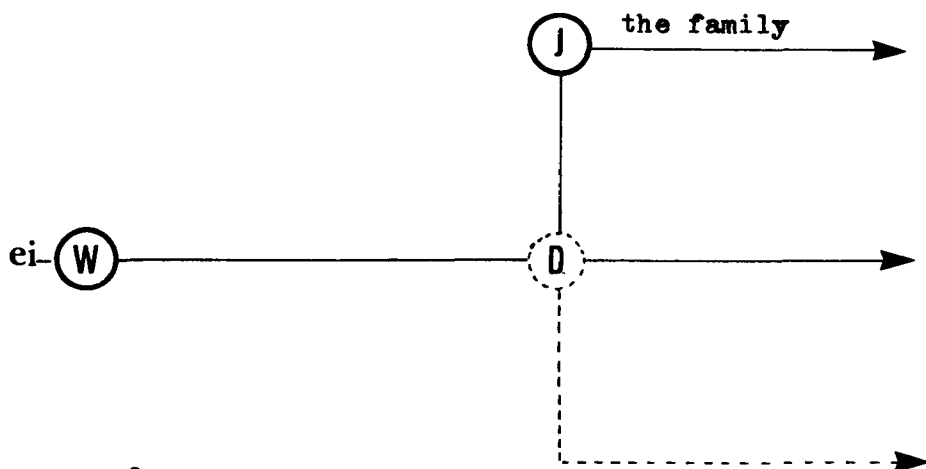

Fig. 48.

The supposition may be that the family offers a protective shelter, a sanctuary (and Walker calls Joe a 'boy'); implying an identity which precedes the outside world's attempt to re-define Joe's work and therefore Joe himself.* There is a parallel to this in his son's decision to become a priest, as if in response to the problems he has in finding an identity for himself amidst the competitiveness of his peers.

The central section of A Question of Honor consists of a chain of events which Joe believes himself to be controlling and which he thinks will

* the family as 'affinal' (rather than simply conjugal): as approaching a condition of 'circular' unification, see pp.467-68

lead him to uncover the American connection in the drug operation which Danzie has been supplying. In fact, for the most part, Walker and his organisation stay one step ahead. This develops into nothing other than two conflicting definitions of reality.

Billy Goldenberg's¹⁸ brooding electronic score which insinuates itself almost imperceptibly around the ragged edges of conversations and then bursts into occasional, unsettling snarls over the increasingly eerie blues and greys of the half-deserted city streets, begins to emphasise the shifting of the ground here as Joe's matter-of-fact certainties begin to come apart. This is not another exercise in paranoia though. Joe is not constantly looking over his shoulder and peering suspiciously into shadows. Instead, and this is partly what makes A Question of Honor so interesting, he presses stubbornly on, insisting that he knows what he is doing to the end. The city streets here are not overflowing garishly with a kind of life in which a man could drown were he not, like Travis Bickle, protected by the thin yellow walls of his submersible capsule. These streets are a desert of metal and stone where Joe huddles stoically against an icy wind.

It is necessary to belabour ourselves with some of the plot contortions if Joe's situation is to be grasped. Thinking that Danzie is going to help him incriminate the gangland heroin dealers, Joe remains entirely unaware that he is himself the target of Danzie's activities and that, through Danzie, Walker intends to trap him. Persistently offered money by Danzie, Joe eventually sees it as a way of exerting more control over the Italian: by taking the money but holding the package unopened Joe believes he can subsequently threaten Danzie with a charge of attempted bribery. Walker's men, however, have the exchange taped and so, unknown to Joe, it is over his head that the threat will hang. Setting up a complex operation which supposedly involves Danzie in returning to Italy, leaving America illegally in order to set up a deal which Joe will then foil at his end, Joe's interpretation of events goes entirely askew. Danzie, in fact, stays in the city as a guest of the Justice Department, and Walker's operation even extends to intercepting Joe's 'phone call to Milan and re-routing it to Danzie who is still in New York. Joe eventually discovers Danzie's presence in the city and, believing that he has returned prematurely from

Italy, illegally taps his 'phone in the hope of discovering what the Italian is doing, the assumption being that it involves the (spurious) narcotics deal; 'He says Monday, he slips in Friday, makes the deal when he thinks I'm not looking for him. Only thing is, I am looking for him and when I find him I'm going to lay it on the line, "You hand up the deal or you go in for bribery".' But Joe is living in a fiction (within a fiction). Walker's men arrest him for the illegal 'phone tap and for taking Danzie's money in return for letting him go back to Italy. So it is Joe who is offered a choice when Walker lays it on the line; 'You can work for us, you can go to jail, or you can blow your brains out'. Joe blows his brains out. In the diegesis the question of why seems redundant given the trap in which Joe finds himself, but in terms of structure and suppositions we can still usefully ask why we are given this terminating event. In the diegesis it terminates Joe's life. What does it do within the structure and suppositions?

On the first occasion in A Question of Honor of an intimate moment between Joe and his wife the predictable question arises of the amount of time he does not spend at home; 'Come on Jeannie, I have a job!'. 'You've also got this family', 'I

know that...'. But Joe does not know it in the way Jeannie does. His sense of self is so bound up in the job that what his family offers goes unrecognised when he needs it most. The concept of 'family' is for him disseminated as norm for all relations within which Joe has a juridical status under the tutelage of a higher authority to which he owes obedience and respect, an authority which has more significance even than Joe's dead father and his own limited but actual parental function. What Jeannie resists, in favour of the actual family and its needs, is this general 'familialization'.

When Joe's job takes him into the apartment of the film's other strong female character, Mickie, a young waitress who has a brief affair with Danzie, amused by his easy Latin charm ('He's fun to be with, makes me feel special'), there occurs a virtually subliminal piece of colour coding. When Danzie tests the quality of the heroin in the opening Italian scene he places a small quantity in a vial of liquid and, held to the light in close-up for emphasis, its stark whiteness turns to a bright blue. When Joe visits Mickie looking for information, she changes from her starchy white uniform into a robe which is, from head to toe, precisely the same distinctive

blue. Joe is as impressed by this transformation as Danzie is by the one he witnesses. But the film refuses its own offer of a problem and a threat in active female sexuality. Mickie attempts, quite charmingly, a seduction which Joe, cool without being entirely unresponsive, resists; he has a job to do after all! What is constructed here, however, is not a moment when female sexuality is rendered menacing, as in the episodes of Kojak and Baretta, but rather a moment when that possibility is met and its potential discharged. Even when Jeannie is chiding Joe about his job, their intimacy has a physical charge. Ben Gazzara and Carol Rossen portray this relationship with such easy and warm physicality that Joe's rejection of Mickie's advances comes across as a rejection of the sexual disguise for the events in which they are involved. Both Mickie and Joe emerge with characters which are, in a sense, clearer than they were within the provisions of the narrative to that point. There is no hidden or potentially threatening secret about Mickie's hedonism. She remains an attractive character, her independence and self-confidence admirably intact. The heroin which Joe is concerned about is just part of a real drug problem and is not displaced into a sexual mythology of

corruption within the general 'familialization'. And if Joe is frightened of anything it is the all too real power which Walker represents rather than some mysterious vagina dentata lurking in the recesses of the film, like Felicity in Wall Street Gunslinger. 'You're OK, Mick' are Joe's last words to her at their final meeting, when she tells him presciently, 'Take care of yourself will you? Nothing's that important'. But for Joe the struggle to continue believing in the larger pattern of 'familialized' authority and obedience is that important.

Had he accepted Mickie's offer he could have taken on a 'guilt' for which Walker's power would have been punishing him. Walker calls him a 'whore' but for Joe there is no such disguise for the situation in which he finally finds himself (or rather loses himself), no displacement which 'explains' his suffering. As he huddles wearily in his car, chain-smoking hour after hour on the empty blue-grey streets the film intercuts warmly coloured domestic scenes marked by his absence; the family at breakfast, his wife in bed. He watches boys playing on the sidewalk, a mother and child going for a walk. In the bedroom where he will lock himself away for days, his strength ebbing, he distantly tells his wife about Walker's

offer of three options. She offers him quite clearly a fourth, an identity which the film has held as a possibility from the moment of Joe's first appearance. She is confused and distressed but imparts to the offer a measure of conviction which makes of it more than some token gesture: 'You don't owe that damn job a thing', to which Joe replies 'I gave my life to it'. The reply is from a man already dead. Nevertheless Jeannie reaches for words that will convince Joe he still exists for his family, that he is not the empty shell which Walker would make of him, but comes down finally to the belated appeal, 'Don't!' The meals at his mother's house go on without him.

In the car on his way to meet Walker with his decision Joe muses, 'Joltin' Joe has left and gone away'.¹⁹ Moments later he is dead and his partner stands weeping in the street. Joe dies because of the disparity which the film reveals between the sources of his self-definition and the position available to him under the repressive institutional power represented by Walker.

Fig. 49.

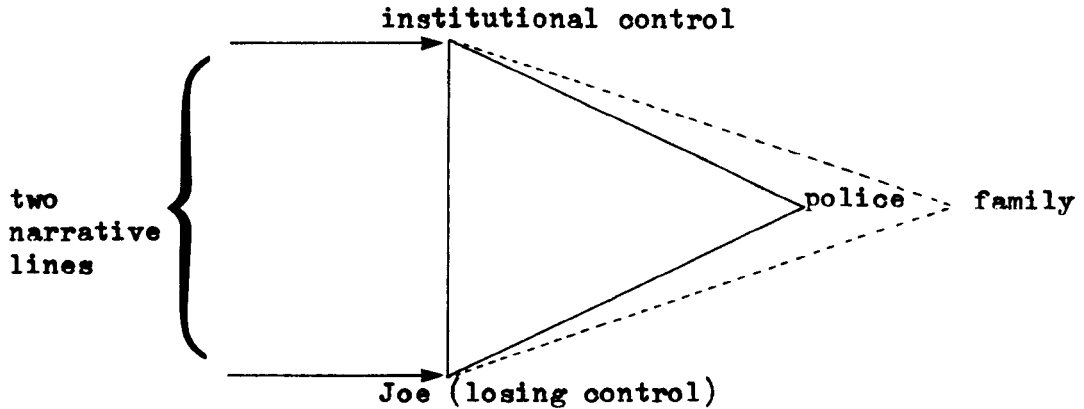

The group to which Joe understands himself as belonging is represented primarily by the police within a supposed structure (as seen from Joe's 'line') of benevolently paternalistic authority, rather than the actual family group defended by Jeannie. Walker's betrayal of this authority destroys also that measure of authority within Joe which he brings to his own family but which has its source rather in the larger well of authority which feeds Joe's concept of the police and, therefore, of himself. He cannot split the terms 'police' and 'man' because the gun and the badge signify an essential phallic sovereignty in which he knows himself as part of this larger familialized pattern. With this gone he is only a shell. This Joe (who is not the Joe his family still care about) 'has left and gone away'.

This pessimistic conclusion will show up some of the ways in which such areas of difficulty and contradiction are avoided or manipulated elsewhere in dominant cinema. It is possible to superimpose on the levels read out of A Question of Honor, three terms operative within the Sartrean system; institutions (Walker etc.), groups (police/family) and series (Joe's final isolation, as well as the actual position of the audience). Such a superimposition is intended not to do violence to the film's internal organisation but to find ways, which the film does not itself provide, to think through the relations among the levels, relations which run across the border between internal and external.

6.3 Intelligibility/Flight

Institutions, groups, series: Sartre provides a framework for understanding the thread of intelligibility which runs through these levels of human relations. The fusion of a group out of the series, in relation to some common object, is a useful starting point. It is in fact the moment which police fiction on screen stages with compulsive repetition; the moment of threat/protection occasioned by the other, the deviant, the trouble-maker who is strictly not, of course, any more of an outsider than anyone else in the series.

While organisation (a significantly ambiguous word, covering both actions within the group and the group itself) enables the group to survive, the fall into seriality remains a constant danger. And there is also the danger that in some way seriality will creep up into the interior of the group, up the xylem as it were, and eat away at the organisation. Such invasions are checked by violence, by generalised policing, by internal terror, by power; according to Sartre, terror is jurisdiction. So there is a central paradox here. Organisation entails a division of labour but with sub-groups or even individuals going about separate tasks what happens to that

founding sense of common activity? At the level of practical activity within graspable limits and with recognisable ends this paradox is held in check by the immediacy, the transparency, of action in common, like winning a game as a team through the scoring of points by individual members. As long as there is this kind of concentrated unity, as long as there is some sort of touchline bounding the group, internal contradictions will tend to be suppressed (although, for instance, a 'star' member of a team may put excessive emphasis on individual action and make the group as a group seem less essential, thus jeopardising its sense of unity). But with more remote ends and less graspable limits (because of geographical separation, for example) the individual tends towards 'losing touch' and organisation tends to erode unless some measures are taken to keep the individual 'inside', even if only through some sort of passive quasi-unity.

This untranscendable conflict between the individual and the common, which oppose and define each other and each of which returns into the other as its profound truth, is naturally manifested in new contradictions within the organised group; and these contradictions are expressed by a new transformation of the group; the organisation is transformed into a hierarchy, and pledges give rise to institutions.²⁰

As the intelligibility of common practice (understood as a kind of amplification of individual activity) recedes from the individual and the central paradox of his position returns with particular force, institutionalisation seeks to homogenise the multiplicity from above, a kind of 'systematic petrification'²¹ reinforcing the original division of labour. The attempt is, in a certain sense, to make the group into an individual; an impossible reversal of the process up to that level, an attempted reversal which has its new intelligibility embodied in the figure of the sovereign individual. The ordinary individual within the institution comes increasingly to resemble a machine, programmed elsewhere. The lines of programming emanate from the sovereign (individual or group; sovereignty being essentially 'an apparatus which constitutes itself inside groups which are institutionalising themselves'²²) and the authority of the sovereign is, therefore, necessarily illegitimate, holding together by power, as it does, series and groups which would otherwise tend to reserialise entirely. Were this ineluctable tendency not there, the sovereign and the hierarchical apparatus on which sovereignty depends, would be redundant.

It is important to bear in mind that this is not a picture of 'society' (or of the movement which history imparts to such a 'picture'); it is not an exercise in jumping out of the system but rather a framework within which the intelligibility to itself of the body of social relations and institutions within which a large number of people live, may be grasped. There must be, moreover, an imbrication of such frameworks; at various levels authority and power will tend to cluster 'above' to the degree that seriality re-emerges 'below'. The focussing of this authority and power on a single personality rather than a group is most likely when reserialisation seems rampant (because of unemployment and inflation, for instance).

The institution, which 'defines men as the inessential means of its perpetuation',²³ promotes a notion of common practice: 'The institutional moment, in the group, corresponds to what might be called the systematic self-domestication of man by man'.²⁴ In a social formation everyone is born into this domestication, into a language ('language and culture are not inside the individual like stamps registered by his nervous system. It is the individual who is inside culture and inside language...')²⁵, into prefabricated obligations

and so on. The stages of group formation do not have to be gone through time and again from scratch, as it were. Rather they are the underlying formal intelligibility of the institutional framework as it exists.

The separation and powerlessness which characterise the condition of these 'inessential' persons, tend to raise the threshold of communication; functions may be deeply interconnected but the machinery of the institution works to isolate individuals as mere functionⁿaries (archetypally on the assembly-line or in uniform). It is at this level that a certain apparent irrelevancy of attitudes is encountered; 'It is too bad if I do not agree: I shall have to come to terms with it', or (and although the opposite attitude it comes to the same thing) 'since it cannot be changed, it is just as well that I am willing to go along with it.'²⁶

Since his [the sovereign's] authority is based on serial impotence, and given that he exploits the inertia of internal relations in order to give the group the greatest possible external efficiency, it must be acknowledged that his power is not based on consent (as a positive act of adhesion), but rather that consent to his power is an interiorisation of the impossibility of resisting it.²⁷

It is at this level that the most widespread means of communication is 'the serial unity of the mass media'.²⁸ In referring to objects which are socially prized or acclaimed (specifically to books and sound recordings, but clearly applicable to films) in order to produce a quasi-unity by the manipulation and indeed the conditioning of the series, Sartre emphasizes the fact that such judgements tend to go unchallenged in practice because even when a person states another preference, that statement is made in relation to the given unchangeable fact of the original judgement. As a result an acclaimed film, for example, whether the acclaim is constituted by an accumulation of good reviews or, eventually, of volumes in a university library, or prized in the literal sense to which the various awards and most festivals are devoted, will become something which very many people must see, even if only to be in a position to state another preference. So even those who 'dislike' the acclaimed film are first and foremost implicated in the quasi-unity which it produces. A kind of jury, a group of 'experts', is almost always involved in this process. It may be the reviewers for the national newspapers, a committee for some prize-giving event, the

editorial board of an influential magazine or journal, but crucially they must, for the most part, appear to be channeling back to serial individuals (potential ticket-buyers, television-viewers, video-renters) the opinion of all, of which the individual was necessarily unaware because of the separation which characterises the series.

This becomes particularly clear in the case of 'top ten' and 'best seller' lists which claim to show the series what it is doing (buying) and what it prefers, whereas of course these 'choices' have always already been made by availability (distribution), by advertising, by the last set of lists, and so on. Sartre refers specifically to a 'top ten' listing of records on American radio; 'it indicates to the temporarily isolated individual that a broad social process of unification and agreement has taken place this week and that the listener at whom the broadcast is aimed has not taken part in it'.²⁹ This accumulation of acclaim for a particular object exerts a definite pressure; 'It is because of the totalisation of serial results by the group that (the isolated person) now feels the need for an explanation...'.³⁰

This is even more evident, perhaps, in the case of an acclaimed film. Few people simply state that they did not see it; the position seems to require that an explanation be given lest the temporarily isolated individual should appear to be too 'out of touch'. There are, of course, wheels within wheels here, and particular sections of the series will experience their own pressure; the 'art' film which must be seen by a certain section of the cinema-going public, for example, or the 'blue' movie which is acclaimed within very particular circles. These are only regional instances of the overall process by which watching the film of the moment is, like buying a best-seller or a top-ten hit, a ceremony which occludes the fact that the individual action is only 'the isolated reactualisation of a unity which has never existed except in the concerted efforts of an advertising group'.³¹

At its base, therefore, this whole operation takes two people, isolated in seriality, and gives them a film (book, recording, etc.) to talk about and to experience within a quasi-unity. If one of them happens not to have seen the film, the other's attempt at communication may be received as an accusation (basically of being out of touch,

but in more elaborate guise, perhaps, of lacking 'taste'). The 'success' of the operation within dominant cinema is that so often this accusation is anticipated and avoided. (Falling attendances are perhaps less a matter of the accusation losing its pressure than of whole sections of people being diverted so that for them the accusation does not occur in relation to a film but in relation to some other object.) Thus the relation of separation is taken to its spiralling limits by making the serial individual do the same as everyone else in order to become the same as them while everyone else is trying to become the same as everyone else and so on, ad infinitum because there is no essential Same to become.

Sartre refers to this endless shifting as flight and identifies certain lines of flight ; characteristics, habits, customs and so on, which the attempt to be the same will pass through and which the mass media reflect and reinforce. Sartre puts the logical outcome of the attempt quite succinctly; 'if he can afford to buy every week's No.1 record, he will end up with the record collection of the Other, that is to say, the collection of no one.'³² But if the advertisers do their job well a person will

hardly notice this strange state of affairs. Indeed the habit of buying the weekly record will appear as natural; as 'second nature' in fact.

If then, as seems entirely inevitable from this perspective, popular film offers certain lines of flight, it does so not just in the sense that over twenty-six million dollars of rental income from Dirty Harry's initial release period represents a quasi-unity for a sizeable number of ticket buyers by the mere fact of their having bought tickets,³³ but also in the sense that the impression of representation afforded by such material will not allow what the films look and sound like and the kinds of readings they demand, to be innocently detached from the way the films operate within the economic and social institutions of dominant cinema and television. It is necessary to understand both the 'outside' and the 'inside' of a film in relation to those aspects of the formal intelligibility of social relations which have been outlined. This necessity should be plain enough when the films in question deal with (or repress, which is a way of dealing with) issues of social control, in particular the function of the police and the definition of crime (and of deviance in general).

If certain habits of seeing (or not-seeing) these and related issues quietly claim for themselves a representational accuracy and are as much a matter of second nature as the habits of 'buying' the film as a commodity, then Sartre's analysis of media commodities is as applicable to textual as it is to institutional aspects. After all, the viewer is not buying some strips of celluloid which can be taken home. What does (s)he take home?

The textual aspects of the kind of film under consideration here are based quite fundamentally on the impression of representation of comprehensible human relations, relations for which explanations can be given and understood (broadly gatherable into 'themes' according to one approach). Certain adventurous texts, such as Badlands, may toy with this comprehensibility but it remains central to dominant cinema and to the cinematic within dominant television. So if a certain comprehension (like a measured dose?) is taken home, it remains to formulate the investigation of the police film in such a way as to suggest just what this might be. The question of sovereignty, where the circularity of flight is checked, is crucial.

CHAPTER 7

IMITATIVE DESIRE

7.1 Sovereignty/discourse

What is centrally at issue in the question of the comprehensible and the intelligible is the nature of the preconditions of class consciousness in social reality, what Jameson has referred to as the requirement that classes be perceptible as such; 'the need for social reality and everyday life to have developed to the point at which its underlying class structure becomes representable in tangible form'.^{1*} This is basically a requirement in the area of culture. The underlying class structure is the 'picture' of social relations which, it has been insisted here, is not offered by Sartre's analysis of the formal intelligibility of human relations known from within. Rather Sartre is dealing with, in a

* notes and references begin on p.741

sense, how the already perceptible moves and is understood, where class interests are realised without in themselves being necessarily and directly perceptible. Indeed it is inherent in Sartre's analysis of the relationship of groups and series that the potential for such consciousness is inevitably stolen from a formation (it is not available in the first place, of course, if class is thought only in terms of economic categories). It is a potential most clearly present to the fused group, newly formed and directly opposed to seriality, but which is lost in the inevitable degradation of such a community according to the 'set of formal contexts, curves, structures and conditionings which constitute the formal milieu in which the historical concrete must necessarily occur'.² The shift from the serial attitude, 'why fight back if the others do not?', through the urgency of a challenge to the interests of each and therefore of all, to the demand from within an initially active and unstructured community that the fall into serial separation be resisted, and ultimately to the re-emergence of seriality within now ossified structures, is a shift through levels (none of which represents a stage with any necessary

historical priority) in the knowing of practical relations in the context of propitious circumstances; propitious that is to the intelligibility of such formal metamorphoses, not to class consciousness per se.

There is no romantic notion here of groups constituting and knowing themselves consensually out of a 'voluntary' convergence of individual interests. There is instead the violence (not necessarily physical as has been indicated) which realistically takes hold where a dream of consension proves fanciful. Sartre knows the world of scabs and touts, of fear and betrayal, and sees at work there the constraints and the formal 'curves' along which practical communities slip in time, whatever their ideals and 'consciousness':

Classes are a shifting ensemble of groups and series; within each class, circumstances occasion practical communities which attempt regroupment, under pressure from certain specific emergencies, and which finish by relapsing, to some extent, into seriality... if they [regroupments] occur within the dominant classes, then, whatever their aim, they necessarily participate in the process-practices of domination.. [therefore] the formation of a State, as a permanent institution and as a constraint imposed by a group on all serialities, can occur only through a complex dialectic of groups and series within the dominant class... . It embodies and realises the general interest of the dominant class over and above the antagonisms and conflicts of particular interests... .³

So the State 'sets itself the aim of manipulating the collectives without extricating them from seriality',⁴ and it has been suggested how the quasi-unities and lines of flight sold by the mass media are deeply implicated in the realisation of this aim. It has been suggested also that there is no reason to assume any innocence on the part of textual aspects of media commodities in relation to this aim.

The necessity of thinking the State in terms of not only a (repressive) State apparatus but also the ideological institutions which meet 'the need to ensure the strict unity of the apparatus in the face of the dispersal of series'⁵ is suggested if not rigorously explored by Sartre. This is essentially Gramsci's point about the balance between political and civil society--'by which I [Gramsci] mean the hegemony of one social group over the entire nation, exercised through so-called private organisations like the Church, trade unions, or schools'.⁶ Acknowledging a debt to Gramsci, Althusser in his notes towards an investigation of the ideological apparatuses, raises the question of whether these may best be considered as simply private institutions or as State apparatuses, and follows Gramsci's example

by insisting that the State is itself 'the precondition for any distinction between public and private'⁷ and, therefore, that the very allocation of certain institutions to the 'private' domain is part of their functioning as apparatuses of the State. For Althusser this functioning has a double aspect; predominant and secondary functions. This adds subtlety to the distinction between the State apparatus as conventionally conceived (overtly linked institutions such as government, army, police, prisons, etc.) and the plurality of ideological State apparatuses (one would want to add the media to Gramsci's list for example):

This is the fact that the (Repressive) State Apparatus functions massively and predominantly by repression (including physical repression), while functioning secondarily by ideology... .

In the same way, but inversely, it is essential to say that for their part the Ideological State Apparatuses function massively and predominantly by ideology, but they also function secondarily by repression, even if ultimately, but only ultimately, this is very attenuated and concealed, even symbolic.⁸

The distinction which Althusser makes here is an undoubtedly important one. It inserts itself into the area where Sartre's concept of violence perhaps occludes the necessity of thinking

such differences but, in turn, Althusser's notion of violence ('every State Apparatus, whether Repressive or Ideological, "functions" both by violence and by ideology...'⁹) is simplistic. Either the violence of the oppressors bears down on the oppressed (through the predominant function of the RSA and the secondary function of the ISAs) or the oppressed, 'by conquering combat positions'¹⁰ and so on, direct their own violence at the oppressors. Whereas for Sartre, violence ('It is called terror when it defines the bond of fraternity itself; it bears the name of oppression when it is used against one or more individuals...'¹¹) is not some kind of boxing match (often an implicit model of class struggle¹²) because there are no unitary antagonists, fearful of each other. Instead where one might expect to find such a fearful antagonist there is a reflexive fear, a constant struggle against seriality and at root the untranscendable conflict between the individual, constantly threatening dispersal, and the common. Violence is not simply a weapon which can bear down from above or up from below. Rather it is a function of the continuous reinvention of fear, 'above', 'below', and throughout. This is, as Laing neatly summarises it, 'the project of substituting a real fear, produced by the group

itself, for the external fear that is becoming remote, and whose very remoteness is suspected as deceptive.... Terror is the reign in the group of absolute violence on its members'.¹³ This applies to any group, at whatever level in the social formation. Violence is action to forestall the fall into (or the rise of) seriality. As such in class society it will certainly be directed from elsewhere against the group (oppression), but it will also be directed by the group against itself (terror). It is this 'horizontal' dimension of violence that Althusser misses by concentrating on the 'vertical' channels of the repressive function within the apparatuses of the State.

Unity, instead of continuing endlessly to pass through each participant in the heat of action undergoes a kind of entropy; it must still exist somewhere but is lost to the direct experience of the participants. It accretes in the activity of the sovereign group, indeed is embodied by the sovereign in the case of an individual in that position. The acceptance of sovereign authority over and above the moment of fragile circulating co-authority is not, following Sartre's argument, a matter of trust as might be supposed but rather,

given the context of violence, of mistrust; the suspicion which characterises the relationship of separate and powerless individuals is foisted on to the authorities whose responsibility it becomes to keep seriality and disintegration at bay (whatever the level, be it a team manager or the State).

The ever-present risk for the State is clearly, therefore, that those who accept constraint as a means to a common end (constraint which includes the practices of all those groups whose management mediates between sovereign and series) will lose sight of (or confidence in) that end and question the repressive apparatuses which may have hitherto been an everyday given, an accepted means to a desirable condition of cohesion. Enter the ideological apparatuses but, crucially, on the stage of the fundamental contradiction which Sartre's analysis has exposed:

The sovereign reigns through and over the impotence of all; their living practical union would make his function useless, and indeed impossible to perform. However, his proper activity is to struggle against the invasion of the group by seriality, that is to say, against the very conditions which make his office legitimate and possible.¹⁴

The insertion and maintenance of sovereignty becomes, therefore, a matter of the determination of discourse in order to 'resolve' this contradiction. Conversely, this situation establishes the general conditions of certain discursive contradictions which echo it. Either way there is no actual resolution. The situation described by Sartre remains one which cannot be transcended but which may be disguised.

7.2 Triadic relationships in the imaginary

The precise nature of the determinations of discourse, the necessity for which Sartre has established at the formal level, will depend on the conjuncture and so strictly falls without the scope of Sartre's investigation of formal structures. ('The investigation we are undertaking, though in itself historical, like any other undertaking, does not attempt to discover the movement of History, the evolution of labour or of the relations of production, or class conflicts'.¹⁵) He does make passing reference to general kinds of determination (e.g. the expression of the relationship of sovereign and group in terms of mechanical or organic unity; the group as a machine or as the limbs of the sovereign¹⁶). However, our objective here has been to provide sufficient information in order to begin to detail the specific determinations at work across the space defined by the representation within an ideological apparatus (popular film) of part of the repressive State apparatus (the police).

What can be done, following Sartre, is to represent the formal space in which the conjunctural determinations of discourse will operate. We have had to look no farther than to Sartre himself in

order to begin to see the relevance of the Critique to a study of popular film and the media in relation to this formal space; his study of the radio broadcast is subtle and suggestive. To summarise briefly: People live in the common world which they are born into (thepractico-inert); they live in the midst of already organised social relations and, to some degree, they live out apparently common purposes, mostly legitimized by 'common sense'. These relations and purposes will, to whatever extent, change the common world into which the next generation is born, and so on. The media have today an obvious and ever-increasing impact on that commonness, both in the constitution of quasi-unities (Sameness) and (the two areas being not unconnected) in the construction of 'common sense'. One of the principal aims of the Critique is to investigate the intelligibility of the common world, so clearly it has implications for our understanding of the media and of their messages, which claim to offer a comprehension of their own. (What is defended by the policeman, for example, and what is therefore defined as deviant?)

In the case of popular film (in cinema and TV) there will be two overlapping areas of particular concern: Sartre's thorough exploration

of the various forms of relation throws light on those established around a film as an object in the social field, and provides an informative context in which to read the kinds of relation represented within a film, as well as perhaps finally synthesising the 'around' and the 'within' and the contact between them, into something more encompassing.

The kinds, or forms, of personal and social relations which Sartre delimits do not represent some inevitable linear progression for an individual, a group, a community or a 'society', but rather a 'diagram' of superimposed possibilities, the 'lines' of which cut across the divisions between what is thought of as 'individual' or 'social' and everything in between and, in a sense, deconstruct their illusory unities. There are ways in which personal and social relations as represented on screen, as well as the relations emanating from the entry of the film as an object (in the shape of the screen) into the common field, will be found to 'fit' the diagram of possibilities and these ways will tell us something about the manner in which this area of popular culture functions.¹⁷

This potentially informative synthesis of 'inside' and 'outside' intersects with the way in which, as Jameson states it, 'the external, extrinsic sociological fact or system of realities finds itself inscribed within internal intrinsic experience of the film'.¹⁸ It rests, that is, on the concept of the analogon (which, at root, it is the whole project here to define), the nodal point for these four imbricated areas: reality, the experience of the film, the film (-screen) as an object in the common field, and the (impression of) representation.

Sartre's analogon is the point of contact between the real and the imaginary, the site in a sense of the inevitable 'derealisation' of the real (reality being what is knowable and therefore always already caught up in this). Thus the impersonator Franconay imitating Chevalier is derealised as Franconay:

The artist appears. She wears a straw hat; she protrudes her lower lip, she bends her head forward. I cease to perceive, I read, that is I make a signifying synthesis.¹⁹

This is not a matter of being taken in by a total mask ('the imitation reproduces only a few elements'²⁰), nor is it a question of Chevalier

being revealed through the veil of imitation: 'How is Maurice Chevalier to be found in these fat painted cheeks, that black hair, that feminine body, those female clothes?'²¹ He is to be found precisely in the reading which renders its object present but derealised. To generalise, it is the way in which the real is persistently foreclosed, the Franconays remaining in some sense stubbornly unknowable behind the Chevaliers (the real and the imaginary being not simply opposites, therefore). But there remains something refractory about the real; there is something of it left, if unknowable, in that black hair, that fat body which will not finally go away: 'The hair, the body are perceived as if they were indefinite masses, as filled spaces'.²²

Filled by the imaginary these 'spaces' remain, nevertheless, something before which it may falter; the imaginary may ride perception like a curse but does not ride it irretrievably into the ground, because if the imaginary is a derealisation it must be a derealisation of something, of the real which if unknowable is not necessarily and finally unapproachable.* It is rather what is left over after the reading has taken what it wants. Sartre suggests as much in the case of an object read as 'beautiful':

* The Wild Bunch offers an allegory of this foreclosure of perception, see pp.52-55 (Volume 1)

The object at once appears to be behind itself, becomes untouchable, it is beyond our reach; and hence arises a sort of sad disinterest in it. It is in this sense that we may say that great beauty in a woman kills the desire for her.²³

The imaginary condemns objects to go unperceived, to function as analogons of themselves in a way. So 'Franconay' and 'Chevalier' may be two aspects of one object, the real and the imaginary of that object respectively. (Will 'Franconay' ever emerge from behind or will there always be other superimpositions?) In a sense the impersonator's art is a revealing joke at the expense of what has been termed the 'self-derealization of the world'.²⁴

So the structural nexuses of reading intervene as the sites of another inscription. The task has been set here, not of examining how this takes place on such sites as 'beauty', but rather of considering a broader textual area, the representation of social relations and their policing. In the Critique the intelligibility of such relationships is marked by the priority, over the dyadic relationship, of the triad. It is to the question of the inscription of the triad that we should turn our attention.

The triadic relationship is the fundamental geometry of interpersonal life because self-aware reciprocity replaces alterity, the relation of separation on which seriality is based, through the observation of the dyad by a third party and the interiorisation of this unifying look. This is the potential in Sartre's example of the road-mender and the gardener observed by the bourgeois intellectual (Sartre himself of course):

A binary formation, as the immediate relation of man to man, is the necessary ground of any ternary relation; but conversely, a ternary relation, as the mediation of man amongst men, is the basis on which reciprocity becomes aware of itself as a reciprocal connection. ...But this trinity is not a designation or ideal mark of the human relation: it is inscribed in being, that is to say, in the materiality of individuals. In this sense, reciprocity is not the thesis, nor trinity the synthesis (or conversely): it is lived relations whose content is determined in a given society... .²⁵

So long as there are more than two individuals in the world this basic triadic structure provides for the possibility of all actual, lived relationships, their content determined by 'society' which ultimately operates as a third itself (for example, through such objects as a motel-room; 'Thus, the honeymooners are alone with their motel, which is to say, with the rest of middle-class American society'.²⁶)

The screen also functions as a third; there is no 'individual' way of sitting in a cinema or of watching TV (of honeymooning in a motel-- whatever the participants may think they are doing-- or of opening a tin can for that matter). Where the look of the third may in some circumstances be interiorised (everyone in a group doing his or her turn as third), the audience before the screen remains an ensemble unified from outside. Where the road-mender and the gardener might feel initially remote from each other, they could interiorise the unity which the look of the intellectual offers them and know a working-class solidarity. (But the screen, even as it makes its spectators the same, maintains their separation by turning the situation around on itself, binding them into the imaginary, so that the cinema interior, the TV set, the screen as object, are no longer perceived. (Even before, of course, these things are not in themselves the real; there are always already imaginary superimpositions, 'home', 'entertainment', 'going to the pictures', etc.) The looks of the gardener, the road-mender, or whoever else in the audience, do not find each other in the unity made by the screen as third, for the screen only makes that unity on condition that their looks are directed at it, and so they remain

a serial quasi-unity, (the collective look of the audience becoming in the imaginary the other look in the motel room). Variations on the shot-reverse shot structure are constantly drawing the spectator even deeper into the imaginary space, derealising the actual space between the spectator and the flat screen. What makes this so pleasurable that whole industries have been founded on it?

For the moment it will be useful to concentrate on only a part of this complex question, the part which takes account of the audience as a series. The desire to overcome the separation and powerlessness which characterise serial relationships we might call the desire for deserialisation, in order to emphasise that it is a movement away from seriality, its cause, rather than towards some specific object which may appear to satisfy it. It is not a matter of appetite, therefore, but of avoiding, escaping, forgetting, perhaps dreaming. There is nothing inherently pleasurable about just sitting in an audience (most of us, therefore, like to have a friend along); the pleasure comes from the film, from anticipation while waiting for it to begin and from what it does to the audience as a series once it has begun. Were one to be among others in the same way but without the promise of a film, or

some alternative object (a bus), the situation would most likely be uncomfortable (numbers and available space have an effect) unless work were done to constitute some common goal. (Much vandalism, for example, probably arises from such circumstances, as an escape from seriality rather than an appetite for destruction). It is perhaps sometimes difficult to admit, but a comparable lack of reciprocity, and of alternative devices for dealing with it, in the contemporary family are undoubtedly part of the explanation for the long hours spent in front of the television set. (It is no use, however, bemoaning the fact unless workable alternatives, that is alternatives which take all the pressures into account, are on offer).

Where desire is not simply a matter of a straight line from subject to satisfying object but of some other 'topology' in which many objects may serve, we are dealing with what Girard terms 'mediated' desire.²⁷ We have, in fact, already considered this (without naming it) in relation to 'top ten' lists and what such things tell us about the pressures on the series and the workings of the modern media within these pressures. A specific recording, bestseller, popular film, is

desirable not in itself primarily, but because it is (supposedly) desired by others. (If it turns out to be 'good' it is a bonus, but by then it may be difficult to judge in any case). To participate is, therefore, to find a quasi-unity in the midst of seriality. Sartre clarifies a phenomenon which Girard here speculates about on the basis of a simple double reciprocal mediation in which A imitates B at the same time as B imitates A: 'From being double, reciprocal mediation could become triple, quadruple, multiple, until finally it affects the whole society'.²⁸ This is flight, in Sartre's terminology. And this is the basis of all contemporary advertising; to sell an object on the grounds that it is desirable to others and therefore offers a quasi-unity whether it is, in fact, good, bad, or entirely useless in itself.

Girard's concern, however, is not directly with mediated desire as it informs actual social relations, but as it appears in the novels of Cervantes, Stendhal, Flaubert, Proust and Dostoevsky. Although the levels are not openly articulated, there is a connection between the movement towards more complex and binding forms of reciprocal mediation in the fictional worlds

of these authors and contemporary processes of collective suggestion, the processes by which in our actual social relations 'we sink deeper into the hell of reciprocal mediation'.²⁹ It is necessary, in other words, to think through the way in which mediated desire is a code in which social facts translate into cultural facts and vice versa.

If, as has been argued, not the object of desire but the other, the mediator, is taken as the point of departure it is necessary to consider two overlapping structural geometries; the triangular desire investigated by Girard (i.e. the 'inside') and the triangular desire thus far investigated here (i.e. the 'outside'). In addition to Girard's 'subject', the desiring character in the novel, there is the subject as we understand it, the spectator desiring deserialisation. As these points will be aligned on an axis of mediation rather than in a direct and spontaneous relationship of appetite for some specific object, we can begin to diagram a spatial metaphor:

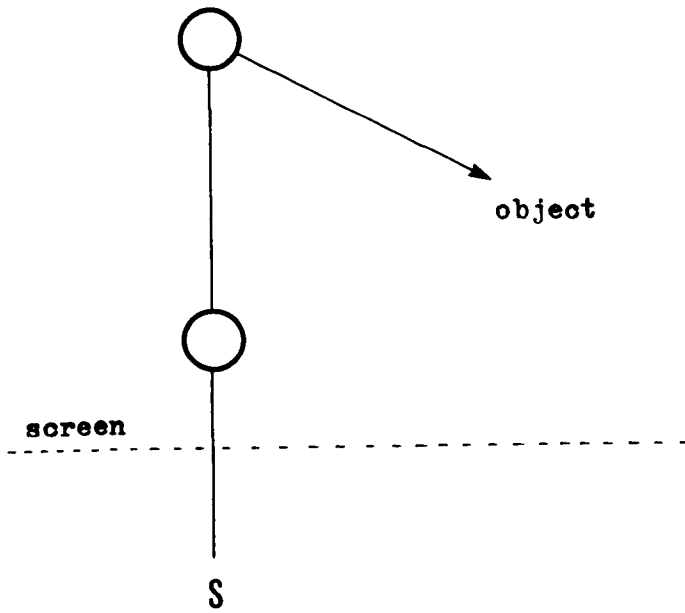

Fig. 50.

S is the spectating subject. The vertical is the axis of mediation. The screen is derealised, no longer seen by S as a flat, actually existing surface. The lower 'node' on the axis is Girard's 'subject', the principal character (this may be the same character throughout or may alter, but in dominant cinema it tends to be one). In a structure of triangular desire this character will mediate between S and the object of desire. Similarly, within the text as Girard's investigation emphasises, there may be for this mediator as 'subject' another mediator which we can represent as a second node at the top of the axis. (This is really all a fiction needs in order to explore or exploit mediated desire, whereas in

actual social relations the pattern may be multiplied dizzily. This is not to say that fictions cannot deal with more complex patterns; just that they tend not to.) So the notion that the Christian's existence is the imitation of Christ (Don Quixote's chivalric existence is the imitation of Amadis, etc.) is paradigmatic of triangular or imitative desire in general.

The object of desire here is whatever fits the cause of desire. In other words the spectator's desire of deserialisation points to a space where the look no longer marks separation and difference (as the gardener might look across the wall at the road-mender and envy his better pair of boots; in scarcity this is how members of a series tend to see each other). Rather, it is exchanged in wholeness among reciprocating members of a group where everyone is momentarily a third, and unification is operated in a circular manner. This is a 'space' rather than a specific object because there is no actually satiating object; the subject's desire is to escape the pressures of seriality (where everyone else is a potential threat) and various objects may occupy the 'space' towards which this 'escape' is indirectly made. What does remain constant is the fact of mediation.

This is because we are dealing here with the imaginary, with quasi-unities and therefore mediated desire. It is important to stress that the space of the object of desire must always seem ill-defined because it is not there and never can be there. It is rather in actual social relations and in the fusion of actual groups out of seriality. The defensive circling of covered wagons or putting on of a show can only be pale imitations; but then there is always John Wayne or Fred Astaire, the mediator.

The woman is often placed as a specific object of desire and is, therefore, set in a complex position in relation to the spectator. In pre-Oedipal terms she is the fullness and completeness of the mother and, therefore, fits the desire for deserialisation, for a release from separation (which becomes, in this sense, a flight back to the breast perhaps?) but as we have seen she is then habitually 'problematized' in dominant cinema, made threatening, the carrier of a dark secret. As Tania Modleski puts it:

The masculine hostility expressed in a film like The Birds stems not from the fear of woman's castrated state, but from the threat she poses in her uncastrated state. The birds themselves become the instrument of phallic revenge on woman's wholeness; they see to it that woman does in fact become the bearer of the wound.³⁰

Similarly the family as a group (seen from outside) fits the space of the object of desire, centred on the completeness and fullness of the first good object, the (not Oedipalized) mother, but again the 'problem' created on the woman then gets in the way and there is a familialization of social relations in order to allow male groups (the Hawksian group under siege, the team of policemen...) to supplant the mothered family (the woman, if she is allowed a position within this other group, becomes 'one of the boys'). So desire is deflected away from the space of unity, completeness, the group, the not-Oedipalized woman and only returns there from somewhere other than the position of the subject, from in fact the third who interrupts the dyad of subject and (space of the) object. This is the mediator who creates a problem in that space, perhaps largely in order to appear to solve it.

The deflection of the subject's desire on to the axis of mediation is precisely the kind of 'abandonment' described by Sartre in the case of the semi-automatic machine (it is the machine which does the desiring in a sense) except that here the mediating machine also provides much of the imaginary 'filling' (characters and events; impressions) for the actual spaces which become a derealised setting.

A series waiting for a film to begin on the screen may, particularly if the beginning is delayed, experience an intensification of the desire for deserialisation; certainly in a large audience the feeling of serial separation and powerlessness may be particularly keen (probably oppressive were it not for the anticipation of release; indeed so predictable has repetition made this release that now there is undoubtedly a certain fore-pleasure in settling into a seat in a crowd knowing what will happen to the crowd when the machine starts to work) and the audience will, therefore, be primed for the opening of this line of flight. In a family setting (whether an actual nuclear family or some other small gathering) this aspect of television may offer an attenuation of the contradictions inherent in a family-type group's constant holding-action against seriality. (Perhaps the shift from the traditional cinema to cinematic forms of home entertainment is partly a shift in the balance between stresses in the series and dominant cinema's effectiveness in temporarily channelling these stresses: if the stresses are now too great then the home marks the next line of defence.)

7.3 Oedipal resolutions

We are now in a position to relate the structural geometries which ^{we} have already described in isolation (Diagrams i-vi). We can add to them Jameson's analysis of Dog Day Afternoon (vii-ix).³¹

Fig. 51.

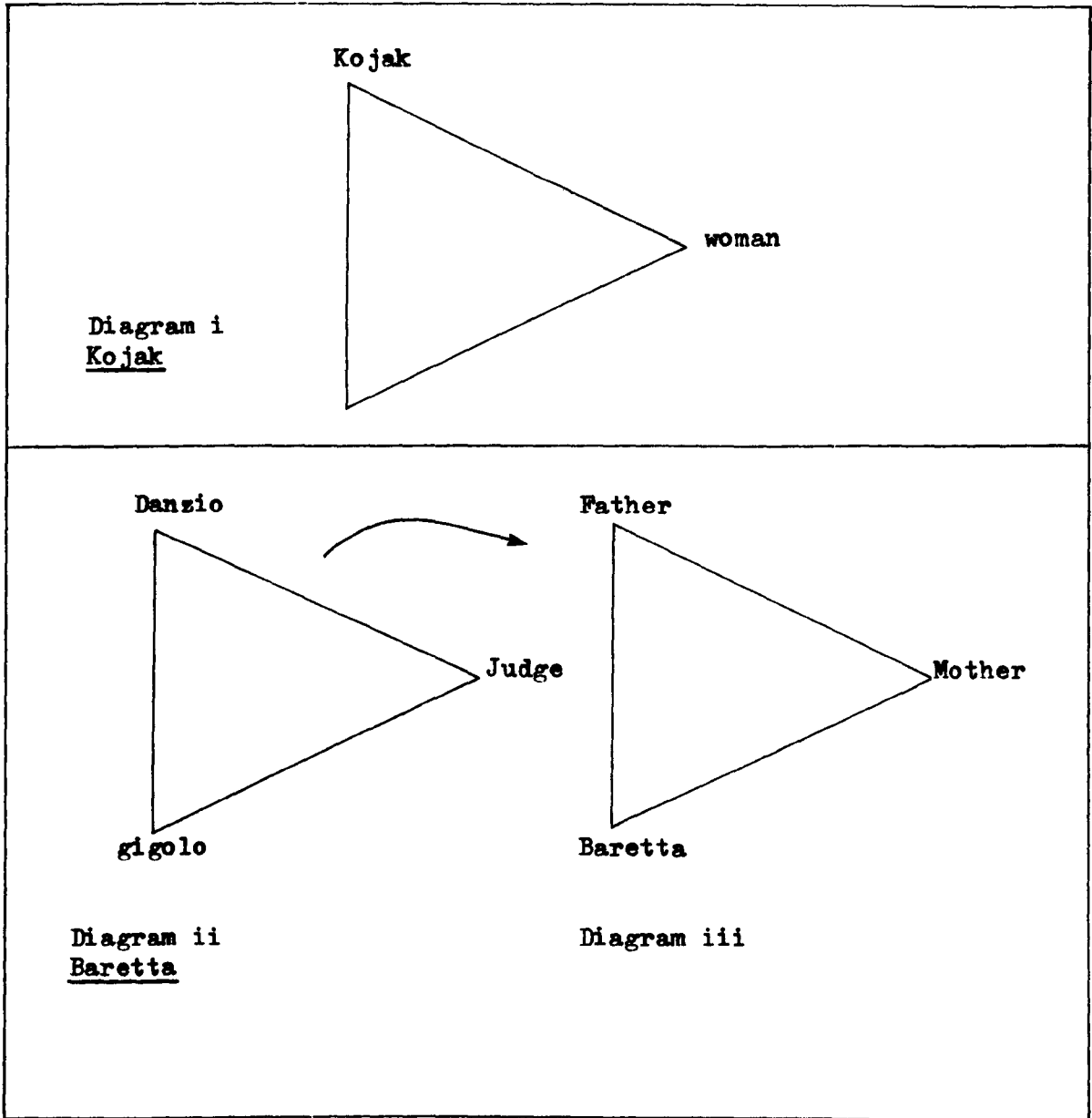

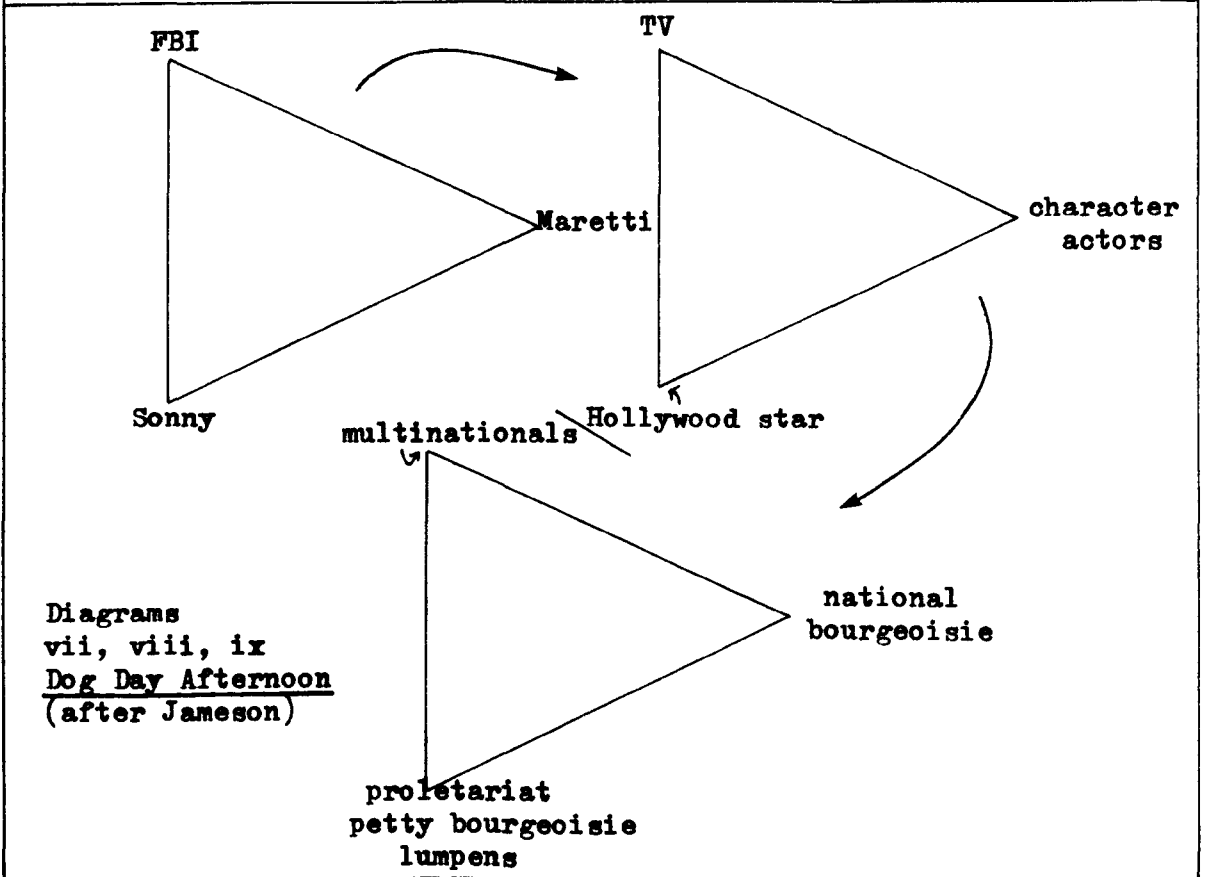
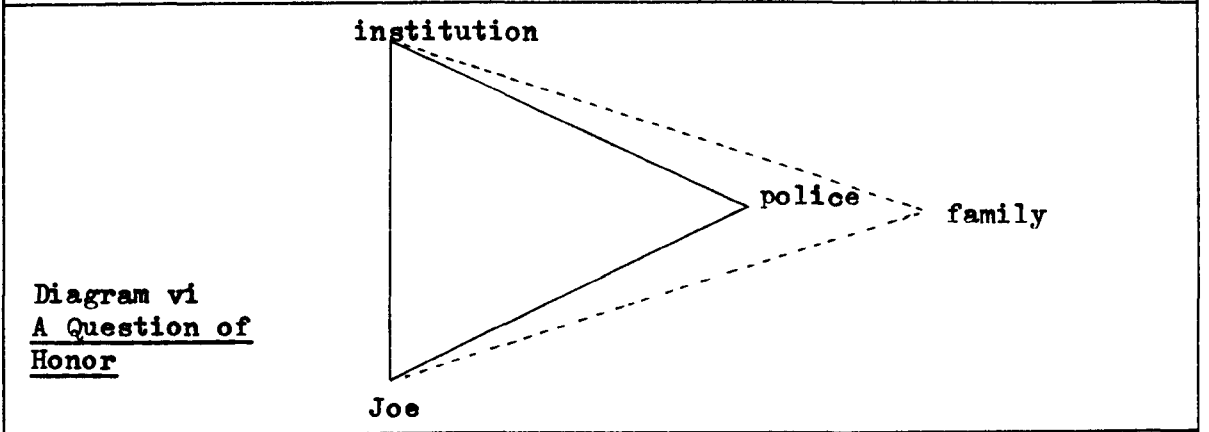
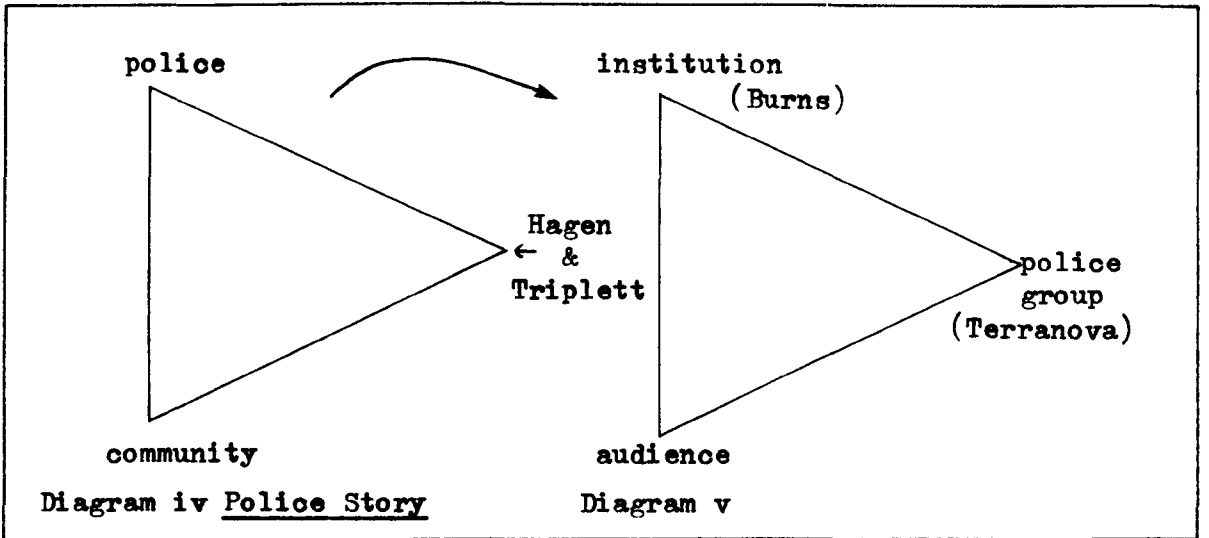

Girard makes some distinctions among various kinds of mediation which will be useful in understanding these patterns. Firstly mediation may be external or internal: the external mediator is remote like Christ or Amadis, there is no possibility of contact, while the internal mediator reduces this distance, is more a part of the subject's world and even potentially a rival as well as a mediator. Then within internal mediation there is 'exogamic' mediation which Girard locates as chiefly operative at the level of 'public and political life' and 'endogamic' mediation which approaches the 'vital centres' of subjectivity.^{32*} Familial patterns will exert most pressure, according to Girard, around 'endogamic' mediations and it is here that the 'subject' most forcefully insists that the relationship to the object of desire is independent of the mediator. Thus in Runway Cowboy, Baretta's actions are spontaneously 'right' rather than required by the absent father or by the institutionalised policing of social relations; we tend to forget that he is a policeman.

There is a potential source of confusion here though. Girard's categories of 'endogamic' and 'exogamic' mark, in the context of a familialisation of social relations, the very

* see the comparable distinction between figurations of political and personal dissent, pp.716-17

confusion of levels which we are trying to untangle. Ironside's position, for example, is 'exogamic' in the sense that it is standing in place of and domesticating institutional power but it works by setting up a 'patrocentric' order, that is by re-inserting itself into the familial model. So when 'endogamic' and 'exogamic' mediations get drawn into a pattern of familialization the terms are too implicated in the disguise to be of much practical use. Instead we may return to the sense in which the two terms mark a secondary external/internal distinction within internal mediation (i.e. 'exogamic' = external-internal mediation and 'endogamic' = internal-internal mediation). It is possible to simplify things, in the present context, by referring to external mediation in Girard's sense as symbolic mediation (as Christ is a symbol) and reserving the terms external and internal mediation for Girard's 'exogamic' and 'endogamic' mediations respectively, thus taking into account the possible familialisation of levels which, in Girard's account, remain 'public and political' only. We need though to bear in mind that Girard's original terms do identify and insist on the importance of familial models in imitative desire. (And more-

over, 'endogamic' arrangements, as Leach points out, 'invariably generate an enormous amount of emotional heat':³³ there is the possibility here of finding a 'progressive' interruption at the potentially most troubled moment in the overall system, and we will return to it later in considering styles of performance.) It is when the need arises to think behind these patterns that the terms could lead to confusion; 'exogamy' mystifying itself as 'endogamy' and vice versa.

It should be clear that Jameson's categories in Diagram ix assume the availability (the 'figurability' as Jameson puts it) of the underlying class structure. In contrast, it has been argued here that Sartre's work suggests the inevitable intervention of another set of 'levels', graspable through the deployment of the categories of series, group and institution (categories which identify the space of wholeness framed by the threat of disintegration and the power that opposes the disintegration, on the threat of which it depends). These intervening 'levels' are graspable in this way for the present purpose precisely because the audience is a series, and this fact is essential to the way in which the screen is derealised and the spectator drawn into

the imaginary space. The terms in the second diagram taken from Jameson (viii) may be read, therefore, in a slightly different way. 'TV' is here used to engage the institutional level (through the actor James Broderick) in contrast to the uniqueness of the Hollywood star (Pacino). The character actors engage a notion of the group precisely because this is how they have been used throughout the history of popular film. ('Gabby' Hayes, Walter Brennan, Arthur Hunnicutt ... in Hawks' films in particular such roles do not establish the group but 'flesh it out', representing its supposed unity and the individual strengths and weaknesses that it embraces.)

That the term 'FBI' is represented by actor James Broderick who, within American television's system of references, is Doug Lawrence, the father (a lawyer) in Family,³⁴ takes on particular resonance when compared with Diagram iii and the way in which the category of 'father' is filled in Police Story. There is a general significance at work here.

Consider this description of that other police investigator, Robert Ironside;

He is a respected and senior man with maximum individual freedom of action, and yet at the same time he is able to tap the resources of a modern and technological institution.³⁵

Again the same writers suggest that 'he gains much of his power from his institutional status' and then locate him in relation to some other examples of the genre:

Ironside's ritual condensation of relationships is supplanted by Kojak's, which is supplanted in turn by Starsky and Hutch. Each of these fictive police series presents a slightly different view of the appropriate way of behaving towards other people, and for a society which finds Starsky's boyish and physical friendship with Hutch appropriate, the paternal common sense of Ironside will emerge as old-fashioned.³⁶

(Ritual condensation = the material representation of abstract values; 'that is to say we may generate abstract ideas in our heads (e.g. the opposition good/bad) and then give these abstractions manifest form by projecting them onto the external world, e.g. good/bad becomes white/black'.³⁷)

These 'slight' differences are in fact a shifting of the mediator along the vertical axis; the institutional-paternal mediator maintaining an aloof distance (Ironside, Kojak) while his offspring (Starsky and Hutch, Baretta) allow a more intimate position for the spectator. (To compensate,

the more remote mediators have assistants towards whom they are most openly paternal; Ironside has Ed Brown, Eve Whitfield (later Fran Belding) and Mark Sanger, Kojak has Bobby Crocker.³⁸⁾ Dog Day Afternoon plays these positions off against each other in the relationship of Sonny/Pacino and the FBI agent/Broderick.

In the replacement of Diagram ii by iii, Baretta secures the apical institutional-paternal position for the return of the temporarily absent father. (Baretta, where there are Kojak and Bobby, has his own ineffectual 'father' in his friend Billy.) Whereas in Diagram iv and v the father is split: the 'good' father proves himself one of the boys while the 'bad' father becomes the object of antagonism, the 'family' group holding the whole structure in a delicate balance. In Diagram vi the family proves insufficient and the very possibility of such a balance is questioned. Here antagonism with the institutional-paternal figure is to the death. A comparison of Diagram i and Diagram vi reveals a sharp distinction between the two versions of the woman's position. In D.i it is the threat, the veiled secret. In D.vi it is the offer of an identity within an actual family, relatively secure from the 'outside' institutional pressures but is finally neglected in favour of the

self-righteousness of the male role in the familialized 'outside'; essentially a phallic role (the gun and the badge) which is revealed as a tragic sham, thereby operating a (limited) critique of the genre.

In Kojak, Felicity 'takes care of' the sheik for Lenny; she is the focal point of the group which he attempts to constitute. But, unknown to Lenny, the nascent 'godfather' Paulus is using Felicity's unfaithfulness to undermine this neat pattern of open relationships. Kojak supplants Paulus, however, and re-stabilizes the structure. He does not, though, uncover Felicity who remains in place for the next time as it were, her sexuality a dormant threat. So Kojak's role is to hold the structure in place from above. Baretta, on the other hand, approaches the woman more intimately; he loves the Judge and it is by establishing this as a particular kind of love (a son's love for a mother, involving a partial renunciation, a disappointment) that he secures what is essentially the same outcome. The difference in method demonstrates the distinction between external and internal mediation.

Kojak is the external mediator, the institutional-paternal figure through whom sovereignty is inserted and maintained 'above';

this is the position coveted by Paulus and Danzio, the mafia bosses; the position secured but not occupied by Baretta, the dutiful 'son', for the father's return; the position of Burns in Police Story as a threatening father, counter-balanced by Terranova's 'buddy' father; the position of Walker in A Question of Honor where the experienced male wins the Oedipal struggle; and the position in Dog Day Afternoon of the FBI agent, who is also Doug Lawrence, the father and lawyer: paternal, institutional, the point of entry of sovereignty, the site of the Law.

At the other end of the scale Joe DeFalco is the internal mediator (with none of Baretta's resilience) who is overwhelmed by the contradictions which this structure would hold in place. He is father-less; his family group centres on his wife and his mother. Walker is neither a benevolent father (Ironside, Kojak) nor a malevolent (split-) father held in check by his benevolent half (Burns and Terranova; fire and earth perhaps as two mutually exclusive but dependent elements). Rather Walker is the exposure of repressive institution-based power as naked violence uncontained by a familialization.

It is possible to formulate an overall geometry for these variations, a geometry based on the range of possible shifts along the axis of mediation.

Fig. 52.

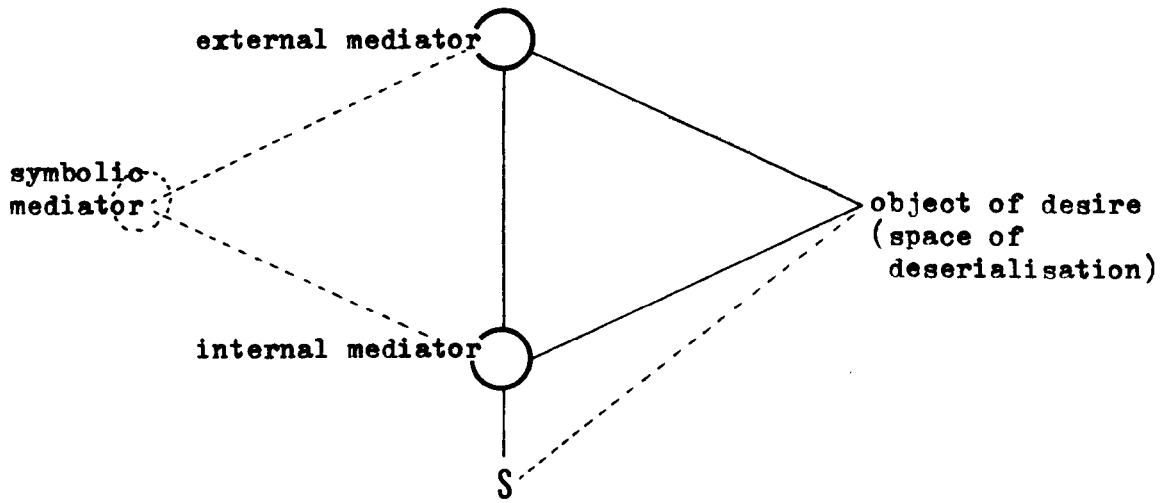

Within the familialization which is being detected, the symbolic mediator is a symbolic Father (no more actual in a sense that the name). The external mediator imitates, without too much effort at concealing the imitation, this Father at the institutional level. Thus Ironside, Kojak and the FBI agent, for example, all act out most clearly the dictates of an institutionalised law. The internal mediator, however, takes pains to deny or conceal any such imitation. The problem may be, for instance, that a 'bad' father gets in the way, obscuring the symbolic mediator. Baretta acts spontaneously (so it seems) according to some inner dictate, some vital sense of what is right, and in an apparently more personal relationship to those around him. And here we find another dimension to Sonny in Dog Day Afternoon; there is

a sense in which he is imitating the FBI agent. Sonny tries his very best to organise the bank raid and then to organise the ensuing fiasco (getting people to the lavatory in orderly fashion, etc.). In fact he burns himself up trying to stay cool and get things organised (and it is all of this that makes audiences laugh and cheer with him); so behind the antagonism between Sonny and the agent who organises everything so coolly and efficiently, there is the fact of Sonny's imitative desire. Joe, in A Question of Honor, is betrayed by his own imitative desire (it is, in fact, when he uses Walker's kind of 'dirty trick' that he gets caught); instead of the Father whom he believes to be there (the symbolic mediator) there is Walker and the pure violence of institutional power.

Clearly we are encountering here a very flexible structure (or rather a set of textual operations graspable in this structure). Any amount of rebelliousness can be allowed so long as its apparent challenge to the external mediator (as a position, whether occupied or not) is held in another place, the place of the internal mediator. The anti-authoritarian postures of Sonny or Baretta do not prevent the return of the Father; in fact in disguise they act out an imitative desire, a

desire to be like the Father: 'The most fervent imitation is the most vigorously denied'.³⁹

'Woman' is not allowed to be anything other than an effect of this triangle.

One apparent anomaly in the set of diagrams needs to be pointed out, if it has not already become apparent. In the Police Story film the axis of mediation seems to be abandoned to the 'bad' father once Hagen and Triplett discover him there (and the film begins to flirt with the possibility of a small unstructured group of law-men owing allegiance only to each other). What differentiates this from the pessimistic conclusion of A Question of Honor is that a 'good' father cancels out the 'bad'; the effect is to make Burns' position provisional. The 'weakness' of this structure, however, is what makes the film particularly interesting. (It has to remove the victim totally in order to maintain the audience's sympathy for its group.) Another film from the same series will shortly be considered, a film which seems constructed almost deliberately to repair this weakness.

What is notable in general here is the persistent repetition of an Oedipal patterning and resolution ('the child must still have a father; the mediator'⁴⁰) within the investigative structure,

a repetition which represents the displacement of the underlying geometry erected on the desire that issues from the separation and powerlessness of the person in the serial situation before the screen. The deflection of the desire for deserialisation on to the axis of mediation opens up a range of possibilities: at one extreme the mediator is the patriarchal figure who lays down the law, at the other he is as trapped in impotence as the serial audience, and may die as a result. This potential of internal mediation for the disturbance of the rigidly 'patrocentric' structure need not be realised; as we have found, Baretta can function as an internal mediator while ultimately his work is to re-stabilise the structure. The difference between Kojak and Baretta is that they work on maintaining the structure at different points. Joe's disturbance is of an indirect kind; he does not shake the structure, but by finding his place in it untenable he exposes its contradictions.

Right across this range of possibilities, however, the political is displaced on to the Oedipal. In this way differences in the placement of the mediator in relation to the institutional level and its apparatuses (of which in reality the screen is one, the cinematic apparatus

as it cuts across from 'inside' to 'outside') may be neutralised. Thus Baretta may sport all the rebelliousness of a 'flamboyant Huck Finn'⁴¹ but at the end of the day the Oedipal displacement keeps this 'naturally' in place.

The examples considered above have offered up to view the kinds of manipulation possible within the space towards which the series' desire for deserialisation is diverted and from which it is deflected. The idea of the group is not offered to the series as the solution to its uneasy alterity. (That could lead to the spirit of July 1789 - could it really recur where there is cinema as we know it?⁴²) As the idea of a possibility it is dissipated in a space against which in the last instance is secured and justified the institutional (-paternal) level. Rather than group-unity superseding seriality, seriality is finally held in place: as a gathering ^{the} audience is at the end what it was at the beginning, whatever the changes in personal affective states. What is absent is the place of completeness, of unity, of difference transcended (appearing as a vague space in the imaginary because nothing can actually be done there; the audience cannot get into the imaginary space, and so there are endless stories

to be told, wagons to be circled, territories to be defended, shows to be put on, family troubles to be solved... when always it is the same old story). This place is represented as the space of a difficulty, a problem (the very stuff of stories), typically by problematising the place of woman.

In Runway Cowboy a stable structure is preserved by banishing the active sexuality of the woman, thus reinstating her as (Oedipalized) mother and securing the desire for unity within a family structure, the 'meaning' of which comes from above.

The Oedipal pattern is fixed over the political parameters of triangular desire (the very foundation of the culture industry; the records, the paperbacks, the TV programmes, the films, all of the other; quasi-unities) analysable according to the Sartrean categories. Sovereignty maintained at the institutional level is displaced into this structure where it can be naturalised. This is the fundamental determination of discourse at work across the space defined by the representation within an ideological apparatus (popular film) of part of the repressive State apparatus (the police). This is the binding of the audience into the imaginary.



Why does Joe DeFalco finally shut himself off from what his wife and family have to offer? How can Kojak effect a closure which leaves Felicity undiscovered? The answer appears to lie in the difference between representations of pleasure and power: it is pleasure which Baretta takes away from the Judge, replacing her in the structure of power relations. Power can be exercised through Kojak by blocking the effects of Felicity's pleasure, confining her ineffectually in that one brief medium close shot, in the bedroom (where she belongs?). We even see it in the contrast of Maretti and the FBI agent in Dog Day Afternoon; the one corpulent and bumptious, surrounded by his disorganised group of 'cops' who take such obviously playful pleasure in waving their guns about, the other lean, deadly, organised. And of course there is already a displacement there, from any kind of genuine pleasure on to a boyish toying with big guns; the same 'cops' giggle at Sonny's 'wife'. Police Story engineers a similar displace-

ment, superimposing the 'buddy' relationship and the artificial family group on the actual families. So in several ways but always with the same outcome, power is privileged over pleasure. Either the bedroom is not entered (Kojak and Baretta, the safest way) or the squad-room is superimposed on the bedroom (Police Story).

The woman is pictured as a betrayer, her sexuality to be feared. She has to be put in her place (repeatedly: she must first leave that place in order to be re-placed) but in that place she is powerless and therefore what she embodies there (constructed as the inert, the safe, the uncompetitive) is forced to be inadequate, an exclusion from power. Embodying power through her lawless sexuality (Felicity as criminal, the 'fallen' Judge), she is out of place and must be forced back. In place she is excluded from real power, the desexualised mother (the Judge as a grandmother: 'there are great men but no great women: there are Grand-Mothers instead'⁴³). Not allowed to be a whole, complete mother though; she must take her completeness out into the world of men where part of it (that which is feared, which has power) can be neatly lopped time and again. So she always loses, in a double-bind; in

place she is not enough (so Joe goes back into the world of men to die), out of place she is too much (so Kojak circumscribes the effects of her power, from a safe distance, and Baretta destroys the object of her desire).

This treatment of woman cuts across (decoys) the desire for deserialisation, embarrassing it with its desire for a place of individualism merged, of release from separation, and by deflecting it on to an axis of mediation, around which the structure of an Oedipal resolution holds everything in place, 'reveals' that other place to be the site of undifferentiation, of passivity; woman's place. (Police Story: The Jar experiments with this place, nonetheless, but a question is left in the air; will these men be able to do anything together, or have they condemned themselves as a group to the periphery, to inertia?) In fact what is achieved habitually is the deflection of the series from the promise of reciprocity (actually only realisable 'outside') into an imaginary structure (reflecting a real structure, 'reality' residing somewhere in the reflection) where seriality has always already eaten away at reciprocity and institutionalised power holds everything in place. The Oedipal is the disguise which this achievement wears.

The Oedipal is offered, in a sense therefore, as the knowledge abstracted, the extractable essence, separable from the narrative dross in which it is embedded, the real within the fictive, the essential within the inessential. The text can be sorted and sieved, scraped and rubbed, to get behind the visible surface, to get from the outside to the inside. This is the discovery.

Discovery should be taken in its most literal sense: removing the covering, as the husk is removed from the nut, the peel from the fruit, the veil from the girl...⁴⁴

But we have found that the text is always already one step ahead of such a discovery. The discovery is nothing other than unknowing complicity in a frame. As Robert Scholes pointedly remarks in a similar context, 'we would perhaps do better to wonder what we have lost or hidden by this very finding'.⁴⁵ What are hidden are the very determinations of discourse interested in maintaining seriality and the sovereignty which (even as it appears to struggle against seriality) depends on it, and interested also in occluding the possibilities for co-operative social relations (outside quasi-unities) in the place between seriality and sovereignty.

CHAPTER 8

KNOWLEDGE AND PERFORMANCE

8.1 Imaginatio /ratio/scientia intuitiva

What is being encountered in this Part is a question of limits and reductions. Broadly it is a question of the reduction of the social and political to the ideological and/or the theoretical dimensions. 'For the problem of the cinema is always reduplicated as a problem of the theory of the cinema and we can only extract knowledge from what we are (what we are as persons, what we are as culture and society)' as Metz reminds us.^{1*} If this reduplication is not to be a matter of accepting a decoy (as after all, the cinematic and the theoretical live in the same 'outside', are attached to the same imaginary) it is to be avoided by knowing the epistemological tangle from within. The strands of the investigation of

* notes and references begin on p.743

certain epistemological assumptions (informing here what appears to be the primary investigation) may, therefore, begin to be drawn together before the evidence is summarised and the analogon interpreted.

The Althusserian experiment (carried out by Althusser and others) crudely characterised, has been to push the theoretical reduction towards certain limits without finally embracing an epistemological relativism which locates the world in theory rather than vice versa. The general thrust of this movement has been directed towards counteracting the (seemingly opposing) ideological reduction. And of course at one point in the experiment things went too far, the insistence on theory (Theory) became one-sided, too exclusive. ('It was no doubt on this occasion that the accidental by-product of my theoretical tendency, the young pup called structuralism, slipped between my legs...'²) This seems to have happened because, for a time, 'ideology' was permitted to mark one side of a primitive binary opposition: error and truth.³

Althusser characterises a general tendency within the ill-defined boundaries of structuralism: 'structuralism (or rather: certain structuralists)

tends towards the ideal of the production of the real as an effect of a combinatory of elements',⁴ This is a tendency which he makes no bones about condemning as 'crazy formalist idealism'. The ultimate aim of the Althusserian experiment has not been the reduction of concrete realities and people to the point where they somehow disappear into theory, the ambition undoubtedly of a crudely conceived structuralism, but rather to make a theoretical detour⁵ with the intention throughout of returning to concrete realities (to 'what we are' as Metz puts it, but the detour was long and tortuous and many became impatient waiting for the return). 'Theoreticism' was then (if it is not too much for the metaphor) a temporary deviation from this detour. The detour itself was, in part, via Spinoza. There is in the most general terms a valid comparison to be made between the manner in which Spinoza refers to 'God' without meaning a creative, personal agent, as in theism, separate from what he creates, and the place of the subject in Althusser's thinking. But more specifically, there is Spinoza's nascent theory of ideology:

Men think themselves free inasmuch as they are conscious of their volitions and desires, and never even dream, in their ignorance, of the causes which have disposed them so to wish and desire.⁶

Spinoza sees implicated in this an imaginary attitude which he contrasts with mathematics as a 'standard of verity':

Inasmuch as those who do not understand the nature of things do not verify phenomena in any way, but merely imagine them after a fashion, and mistake their imagination for understanding, such persons firmly believe that there is an order of things, being really ignorant both of things and their own nature.⁷

This imaginary attitude towards things and human nature (perhaps, teases Spinoza, 'God foresaw human imagination, and arranged everything, so that it should be most easily imagined'⁸) is founded on the notion that everything has been so ordered with an end in view, and with the human subject at the centre;

...but in their endeavour to show that nature does nothing in vain, i.e. nothing which is useless to man, they only seem to have demonstrated that nature, the gods, and men are all mad together.⁹ *

* on the comparable consequences of 'instrumental reason' see pp.675-681

Spinoza advocates a refusal of teleology and a displacement of the human subject from the centre (where it tends to arrive by default out of teleology: 'If they cannot learn such causes from external sources, they are compelled to turn to considering themselves...'¹⁰). Instead, knowledge begins by considering the properties of things 'without regard to their final causes',¹¹ in order to counteract this state of affairs--

that all the explanations commonly given of nature are mere modes of imagining, and do not indicate the true nature of anything, but only the constitution of the imagination; and, although they have names, as though they were entities, existing externally to the imagination, I call them entities imaginary rather than real... .¹²

What is missing, of course, from Spinoza is the connection between living in the imaginary (ideology) and living in a class society.

Althusser paid a price, in this respect, for his Spinozistic detour:

But I saw ideology as the universal element of historical existence: and I did not at that time go any further. Thus I disregarded the difference between the regions of ideology and the class tendencies which run through them, divide them, regroup them and bring them into opposition.¹³

This is the terrain, finally, of Sartre's Critique. It is the terrain where Althusser's deviation¹⁴, his 'theoreticism', just as every endeavour tends to escape its initiators ('it becomes, for the very people who initiated it, an external object which tends to dominate them and survive them'¹⁵) has returned time and again to define his enterprise. Like his name, it is fixed in the practico-inert and resists even (perhaps especially) Althusser's own attempts to dislodge it.

In its re-entry into the terrain of class, including class positions in theory, Althusser's work must be considered according to its effects in relation to the 'shifting ensemble of groups and series'¹⁶ which constitute classes.

'Althusserianism', for instance, describes the constitution of precisely a series, united from outside by Althusser's name and work insofar as they have become external objects to Althusser himself, taking on existences of their own, becoming practico-inert. Categories such as 'theoretical production' and the ideology/science antithesis have become immutable, whereas in Althusser's work their usefulness as codes was to be precisely in the fact of their mutability,

once they had served their experimental purposes, once they had helped to clarify certain positions; positions which, as it happens, undermined some of these categories in turn, and displaced others. Within a system of positions categories could be re-worked, but within the practico-inert they defied their own passing. They accreted around Althusser's name and constituted a series ('Althusserianism') devoted to them, and indeed another opposed to them. Out of these series have arisen various groups, their fragile unities susceptible to all the pressures of re-serialisation and institutionalisation; groups, for instance, united around various projects in Marxist cultural studies.¹⁷

When Althusser suggests that a category should be "reworked" from another point of view, which must split it up into the elements of the complex process of the "production" of knowledge,¹⁸ he is implicitly demanding the return of such categories (including his own name) from wherever they have taken themselves off to; from what Sartre terms the practico-inert. Sartre's analysis suggests, however, that they cannot be so simply returned. This, of course, implies a similar fate for 'Sartre'. If we have been staging a dialogical encounter between texts of Althusser and Sartre, it

is not to have a confrontation between 'Althusser' and 'Sartre' as they stand belligerently in the practico-inert but to elicit a useful exchange between positions in Marxist philosophy. (The risk is seen clearly enough in Althusser's own belligerent snipes at 'Sartre', the name). It is an encounter which is being staged with the help of a mediator, Barthes, (largely silent himself in this Part of our own text) whose final work¹⁹ was written in homage to L'Imaginaire, and via a detour through Spinoza's three levels, the last of which is the site of so much trouble. (The 3 is gradually revealing itself in everything.)



The first level, imaginatio, offers the crucial connection between the common-sense notion of the imaginary as thoughts of absent (perhaps unreal) things and sense-perception, the impact of the outside on the body; the connection which is so vital in eliciting Althusser's detour in search

of a materialism of the imaginary. So Spinoza offers the common-sense notion of imagination, implicating it in this respect in memory: 'The mind is able to regard as present external bodies, by which the human body has once been affected, even though they be no longer in existence or present',²⁰ but this is only the corollary of the proposition which grounds the imaginary in sense-perception, in 'the constitution of our own body',²¹ and the impact thereon of external bodies.

This is where Althusser finds the beginnings of a theory of ideology, in the connection between perceptions of the outside world and the 'ideas' which the perceiver has of that world, of the external bodies which make sensory contact with the body of the perceiver. It is here that perception is bound into an imaginary synthesis in which the perceiver 'mistakes for things the forms of his imagination'.²² This is not a matter of simple error ('The mind does not err in the mere act of imagining',²³ insists Spinoza). Rather it is a matter of the expression of the outside by the inside according to what is available: 'the ideas, which we have of external bodies, indicate rather the constitution of our own body...'.²⁴ Spinoza's example is

Paul's idea of Peter which 'indicates rather the disposition of Paul's body than the nature of Peter, and, therefore, while this disposition of Paul's body lasts, Paul's mind will regard Peter as present to itself, even though he no longer exists'.²⁵ Sartre introduces a third term between Peter and Paul; a portrait of Peter, which will act upon Paul as an entreaty (elaborating in advance the Jakobsonian contact) to regard Peter as present, or as Sartre puts it, 'to make the perceptual synthesis: Peter of flesh and bone'.²⁶ And Sartre maintains the Spinozistic perspective. The picture as an object, as Peter himself is/was an object, enters into the imaginary synthesis. Coming between Peter as (absent) object and what Spinoza refers to as the forms of the imagination, it offers, in fact, its own mediatory forms ('such brows, such a smile',²⁷) which entreat the perceiver: 'It is really the entreaty that functions as analogon and it is because of it that my intention is directed to Peter'.^{28*} So in Spinoza's imaginatio, in its essential materialism, its emphasis on concrete existence, its refusal of any simple notion of 'error', there is the common ground for the concepts of the imaginary developed by Althusser and Sartre.

*on perception as absent but 'entreatable' within the imaginary, which it can re-interpret as a Utopian longing rather than a mystifying nostalgia for lost innocence, see pp.50-55 (Vol.1)

Spinoza's second level is ratio. The central proposition is this: 'That, which is common to and a property of the human body and such other bodies as are wont to affect the human body, and which is present equally in each part of either, or in the whole, will be represented by an adequate idea in the mind'.²⁹ A system can be built on this; 'Whatsoever ideas in the mind follow from ideas which are therein adequate, are also themselves adequate'. In this way is formed 'the basis of our ratiocination'.³⁰ Spinoza sees ratio as essentially a matter of counteracting the tendency by which, in what might now be called an overload, 'the mind also imagines all bodies confusedly without any distinction, and will comprehend them, as it were, under one attribute...'.³¹ (There is something of the same emphasis in Marx's 1857 Introduction where he discusses 'population': 'if I begin with population, then that would be a chaotic conception of the whole, and through closer determination I would come analytically to increasingly simpler concepts'.³² Marx advocates a second way of proceeding.) For Spinoza this partly explains the notion of 'man' ('man' is also implicated in teleology) and we have the germ, therefore, of

what Althusser terms Spinoza's 'resolute anti-Cartesianism'.³³ So ratio is a matter of adding certain generalities (the 'common') as the instruments of the production of adequate knowledge. We have here, in other words, the foundations of scientific thinking (and also, incidentally, the first notion of the division between levels of knowledge which Althusser was to formulate, after Bachelard, as the 'epistemological break'). But what exactly are these common characteristics, these generalities on which ratio is based?

What he [Spinoza] does not mean is the sort of common property or class concept on which we base abstract and general ideas. Such ideas, he holds are merely confused and are the result of attempts to combine a multitude of images too numerous to hold together in our minds.³⁴

It is precisely this kind of thinking that Marx has called 'chaotic'; Spinoza has clearly left his mark here.³⁵ Marx proposes, instead, a 'scientifically correct method';³⁶ the gradual 'reproduction of the concrete by means of thinking' through an ascent towards (rather than a descent from) the 'subject', society: 'the method of ascending from the abstract to the concrete is merely the way for thinking to

appropriate the concrete, to reproduce it as a mental concrete'.³⁷ This ascent, this supercession of levels (each involving, suggests Althusser, 'that minimum of non-existent generality without which it would be impossible to perceive and understand what does exist'³⁸) in the production of an increasingly adequate appropriation of the concrete, is explained by Marx as a progression towards the appearance of the concrete in thought as a result, 'although the concrete is the actual starting point and hence also the starting point of perception and conceptualization'.³⁹ The distinction between the 'actual' starting point (Metz's 'what we are' again) and the (re-)appearance of this point as a result in thought is subtle and potentially misleading. Marx clarifies it by basing the ascent on a descent which has always already taken place. Spinoza's analysis of the imaginary synthesis of 'all bodies confusedly', what Marx calls 'chaotic' conceptions of the whole (and Spinoza pinpoints 'man' as one of these, anticipating Hofstadter's discussion of the place of 'our nearly unanalyzable feelings of self'⁴⁰) identifies something unavoidable. (This is central to Althusser's theory of ideology.)

'Chaotic' thinking stems from imaginatio, the level of knowledge founded on the (by definition unavoidable) lived relation with the material world. Ratio becomes, therefore, the site of a struggle, of an ascent achieved against a descent. The aim is to return (therefore strictly a re-appearance rather than an appearance) to the concrete: 'this time, however, not...as a chaotic conception of a whole, but as a rich totality of many determinations and relationships',⁴¹--Marx is quite clear about this. There is, in a sense, therefore, a structural necessity for Spinoza's third level to counterbalance imaginatio as both levels impinge on and derive meaning from ratio. There is also here the general framework within which Sartre proposes the progressive-regressive method, not as a theory of knowledge-production, but as a way of actually producing it, as the 'levels' in action. (Whereas the deviation of 'theoreticism' took Althusser into the third level too soon and too far.) Within the overall conception of the ascent achieved against a descent, Sartre proposes the spiral through which something can actually be done. (If Sartre has his own difficulty it is not theoreticism but an obsession with the individual case study. While this is an over-emphasis within the execution of the method it is not a difficulty in the method itself.)

The third level is scientia intuitiva.

'A true idea in us is an idea which is adequate in God, in so far as he is displayed through the nature of the human mind'.⁴² Spinoza proposes, in short, a level of knowledge which proceeds from an adequate idea of certain of God's attributes to an adequate knowledge of things (including human attributes). What is known at this level is known as it is by God, the immanent cause. It is possible to conceive of this level as a necessary counter-balance to the effects of imaginatio, and it would appear to be on this kind of perspective that Theory established itself against Ideology in the Althusserian scheme. (Only to be disowned, of course, by Althusser himself). If the slide into theoreticism is not to be repeated as a contemporary revision of Spinoza's God, who is the ultimate (though not personal) explanation of everything, it will be necessary to return to Marx via the following perceptive re-formulation of Spinoza's assertion that 'every idea of every body, or of every particular thing actually existing, necessarily involves...God':⁴³

If intuitive thinking 'necessarily involves God', this can mean, namely, that such thinking activity is one of inferring that its ideas of things presuppose and derive from God as ultimate agent. Yet just as well, (however unorthodox it might seem), we can read the same formulation as asserting that the thinking itself is the process that 'involves', in the sense of produces God and his activity as product.⁴⁴

Marx's subject (by 'Subjekt', Marx means structuring agency, rather than subject of study⁴⁵) enters his consideration of the theoretical method in a position analogous to that of Spinoza's immanent cause (the 'content' of both Marx's 'society' and Spinoza's 'God' being Nature, material):

The real subject [Subjekt], after as before, remains outside the head in autonomous existence; while [on the other hand] the head acts, as we say, only speculatively, only theoretically. Hence with the theoretical method the subject [Subjekt], society, must always be borne in mind as the presupposition of [any] conception.⁴⁶

Marx is quite firm in denying that thinking produces the real. Thinking appropriates the concrete but 'this is in no way the process of origination of the concrete itself'.⁴⁷ And yet the two readings of Spinoza's proposition about the 'involvement' of 'God' are persistently caught in a tangled hierarchy. 'God'/'Subjekt'/'Society', as immanent

in its material effects, may be the presupposition which actually exists but it is still not the starting point. ('The concrete appears in thinking as a process of summarization, as a result...'⁴⁸) What then is the nature of the 'involvement' of what we call society, its appearance in knowledge?

Sartre's approach is to question the facility with which such (chaotic?) terms as 'knowledge' and 'society' are bandied. Adopting a perspective close to Marx's in the Economic and Philosophical Manuscripts of 1844 (e.g. 'just as society itself produces man as man, so is society produced by him...when I am active scientifically ...then my activity is social, because I perform it as a man...Above all we must avoid postulating "society" again as an abstraction vis-à-vis the individual. The individual is the social being'⁴⁹), Sartre examines the possibility of twinned movements of comprehension and intellection which traverse social relations (rather than 'society' as an entity). Although these movements (through which, as Marx puts it, 'the head acts') may be thought of as working in opposing directions, Sartre insists that 'the opposition between the intelligible and the comprehensible ought really to be rejected'.⁵⁰ It is in the ferocity of its

antagonism towards (and flight from) imaginatio that 'Althusserianism' has attempted to banish the comprehensible from within the intelligible (Sartre might say, the species from within the genus).

For Sartre the two are interdependent; comprehension grasping (regressively) the Intentionality of an individual or group (the author(s)), 'even if this intention is implicit or obscure to the agent itself' while intellection sweeps this up (progressively) into a critical investigation of 'actions without an agent, productions without a producer... [the] authorless'.⁵¹ The connection, the turn of the spiral which prevents these movements simply opposing each other, is to be found in Sartre's conception of the practico-inert. When the term makes its first appearance in Search for a Method, Hazel Barnes offers this general definition: 'He uses it to refer to the external world, including both the material environment and human structures--the formal rules of a language, public opinion as expressed and moulded by news media, any "worked-over matter" which modifies my conduct by the mere fact of its being there'.⁵² The fragility of human groups arises from the fact that they are precariously balanced between the pressures

of seriality and the practico-inert which steals (or deviates) their every intention. (Culture as practico-inert is referred to by Sartre, in The Family Idiot, as 'the objective mind' and, more playfully, as 'tinned thought'.⁵³) Human intentions become 'engraved' in the practico-inert; 'their translucidity becomes opacity, their tenuousness thickness, their volatile lightness permanence'.⁵⁴

Significations are not, therefore, fixed by consciousness; 'significations are composed of matter alone. Matter retains them as inscriptions ...'.⁵⁵ The comprehension of significations, the re-tracing of Intentionality, is not then in itself the production of knowledge. It is also necessary to double this effect of thought back on itself, to grasp the intelligibility of the ways in which 'significations as passive impenetrability come to replace man'.⁵⁶

A beginning has been made here in considering, for example, the relationship between significations and the social structures of the practico-inert. (This falls within the scope of the overall Sartrean project to find the marks left by 'man' in the world and the marks left by the world in 'man'). Comprehension stops short

of uncovering some inner truth, of abstracting some hidden essence (there is none), and instead is folded back into intellection in order to grasp what is comprehended as responses to a situation, a context. For Sartre the phenomenological perspective, at the core of the 'ideologies of existence', finds its place within comprehension (its role 'is not to describe an abstract "human reality" which has never existed, but constantly to remind anthropology of the existential dimension of the processes studied'). But it is now to be taken up as 'non-knowledge' into the production of knowledge via 'the perpetual redescent [redescending where imaginatio has always already been?] which introduces comprehension into intellection as a dimension of rational non-knowledge at the heart of knowledge'.* This oscillation of comprehension and intellection (of non-knowledge and knowledge) is 'the very ambiguity of a discipline in which the questioner, the question, and the questioned are one'.⁵⁷ It is precisely the neglect, within the main currents of contemporary Marxism, of comprehensive non-knowledge that has maintained hitherto the 'autonomy of the existential ideology'.⁵⁸

* for a more explicit version of this spatial metaphor see p. 731

So Marx's method of 'ascending' to the concrete (Sartre's intellection) is achieved against, in touch with, this 'perpetual redescend' to the lived relation with (referred to by Merleau-Ponty as the insertion in) the material world.*

The apparition that is constituted in a world that produces me by assigning me through the banal singularity of my birth to a unique adventure, while at the same time conferring on me by my situation...a general destiny (a class destiny, a family destiny, an historical destiny), is none other than what I call being-in-the-world...59

It is this apparition, this being-in-the-world that constitutes the object of non-knowledge. It is, suggests Sartre, the object of the literary writer's work, ('his basic aim is not to communicate knowledge'⁶⁰). The task of the écrivain (as an aspect of the writer, rather than a distinct kind of writer) is to present 'the human condition in the form of an object (the work) such that it can be grasped in its most radical depth (being-in-the-world)...the real relationship between reader and writer remains non-knowledge'.⁶¹ This non-knowledge (Sartre also calls it 'silence') emerges in the recomposition (reading) of the work.

* that this is an ascent towards a perception no longer 'chaotic' and degraded (in which imagination now inheres as the figuration of what has still to be achieved) is suggested above, pp.457-59

The écrivain in the writer makes his 'being-in-language the expression of his being-in-the-world' by taking the dead weight of the signified foregathering behind every word ('each vocable brings along with it the profound signification which the whole epoch has given to it'⁶²) and turning it back on itself, re-discovering ('the writer as an adventurer'⁶³) the signifier, in order to 'imprison his relationship with the world, as lived experience, in the material presence of words'.⁶⁴ The words are always too few: 'words, types of reasoning, methods, exist only in limited quantity; among them there are empty spaces, lacunae..'.⁶⁵ So there is always excess and lack simultaneously. Intentional states are enriched and betrayed. There is difference, theft, deviation. The signifier is always being sacrificed, surpassed towards the signified which can then (as, for example, 'polyvalent verbal schemas'⁶⁶) be supported by other signifiers. The task of the écrivain is to return to the material reality of the signifier and to use it to point (as it were, sideways) to the empty spaces, the lacunae. The being-of-the-word-in-language, the insertion of the signifier in the system, is made to express the écrivain's

being-in-the-world. In this way the writer can be an intellectual essentially (while all other intellectuals, according to Sartre, are 'accidentally' so).⁶⁷ (There is here the sense of much being taken for granted; of a European, even a specifically Parisian, literary community being addressed by Sartre on common ground, ground also taken for granted by Barthes' Writing Degree Zero⁶⁸ to which Sartre is clearly responding and which was itself an engagement with his earlier What Is Literature?⁶⁹ This despite the fact that 'A Plea for Intellectuals' was originally delivered in lecture form in Japan. It is curious that one of Sartre's most intimate flirtations with structuralism should have come when he was most geographically distant from its base.)

This is clearly not the imaginary simply as Sartre describes it in L'Imaginaire, the mechanism only of the 'induced dream' and the 'deception' most keenly felt on leaving the theatre or cinema, the discomfort 'we always experience in passing from the world of the theatre or of music into that of our daily affairs',⁷⁰ the workings of imaginatio at the expense, always, of the real. Sartre suggests, finally, the possibility of redeeming the

imaginary. The Barthesian idea of the écrivain re-introduces something of the real into the imaginary, a passage within the imaginary, from imaginatio to comprehension. (The early conception, attacked by Barthes, of literature as literal, as a mirror and then, as Hazel Barnes puts it, 'that nobody should be fiddling with mirrors while the world is burning',⁷¹ is here superseded by something more subtle.) Work on the materiality of the signifier to prevent its complete effacement before the signified is the main ingredient of this comprehension. In exposing the being-of-the-signifier-in-the-system such work expresses (Barthes might say imposes) the subject's being-in-the-world. This 'structuralist' conception of Sartre's can be left, for the moment, in the place where he found it, with Barthes and specifically as it appears in the first paragraph of Writing Degree Zero (which challenges Sartre's earlier advocacy of the literal writer) and from where it can be picked up again:

Hébert, the revolutionary, never began a number of his news-sheet Le Père Duchêne without introducing a sprinkling of 'fucks' and 'damns'. These improprieties had no real meaning, but they had significance. In what way? In that they expressed a whole revolutionary situation. Now

here is an example of a mode of writing whose function is no longer only communication or expression, but the imposition of something beyond language, which is both History and the stand we take in it.⁷²

Scientia intuitiva may now be re-thought as partly the introduction of comprehension into the intellection of ratio. The object of comprehension is the lived relation between men and the world, not as it is always already recognised in imaginatio (which is that relation) but differently. Instead of the Althusserian drive to exclude being-in-the-world from the third level, Generality III, Sartre proposes a fold within knowledge production to carry such non-knowledge, a fold from which social imaginaries such as the literary and the cinematic need not be excluded (although in their dominant modes they tend to exclude themselves, to regress to the level of imaginatio). In this way Marx's 'Subjekt', the 'society' or mode of production, comes gradually to know itself; in Spinoza's terms, knowledge as the 'intellectual love of God'⁷³ is 'part of the infinite love wherewith God loves himself'.⁷⁴ Instead of making 'a fetish of its knowing',⁷⁵ Marxist philosophy can insist that the questioner, as part of his work, should comprehend how the questioned (the questioner again, after all) lives and thinks the workings of advanced capitalism.

Instead of the false choice between theory and experience, there is the fold of comprehension, of non-knowledge, of the subject as agent whose Intentionality is always deflected, betrayed by the practico-inert; a fold within the movement of intellection, of the subject as object, as produced by the practico-inert. Essentially it was only on the third level that the Althusserian experiment went awry and deviated towards a God-like Theory whose self-performance produces the real. (Indeed this was always a 'potentiality' in Spinoza's account of scientia intuitiva.⁷⁶) On the contrary, though, scientia intuitiva knows itself to be folded into the intractable forces of the immanent cause (the mode of production or structure which appears in different codes as 'God' or 'society'). We will return in Part IV to the implications this has for criticism.

8.2 Termination/performance

Police Story : No Margin for Error⁷⁷ reproduces many of the features of Police Story : The Jar. Again the narrative centres on an investigation into a shooting incident involving a black victim and a white policeman on duty. Again the incident and subsequent investigation have repercussions for the officer's family; his young son is bullied at school by black children because a young black woman was killed by a stray bullet from the officer's gun. For these children and the community from which they come he is the 'honky cowboy who blew up a black chick'. Immediately after the shooting a crowd of black people menaces the lone officer and throughout, as in The Jar, the question arises of who the police are working for if the communities in which they work are so instinctively antagonistic. In addition there is institutional pressure, pressure from 'above', to demonstrate that the force's internal investigative procedures are impartial.

The police commissioner is the channel through which these institutional pressures converge on the force: 'There's a good deal of concern over police shootings in the council,

city hall...There's a kind of climate being created in this city, gentlemen, and we're going to have to respond to it whether we like it or not...What people want now are positive results, something they can read in the newspaper'. The lieutenant in charge of the investigation in question (occupying the position of Terranova in The Jar; 'he trusts you', the officer's wife tells him) is uneasy: 'What would you consider positive results, an officer's head?' He finds the commissioner's reply unsettling; 'All I'm going to tell you is that there is a growing number of people who would say, "Well that's a start anyway"'.

Where the narrative structure of The Jar works towards defining a small group of policemen, a quasi-familial grouping, whose practical unity is their defence against such public and institutional pressures, No Margin for Error establishes certain defences from the beginning and more of its structuration goes towards defining the woman's place in relation to these.

When a back-up unit arrives on the scene after the officer, Anderson (James Farentino⁷⁸) has wounded a suspect in a scuffle and accidentally killed the girl, it is two black

officers who protect him from the angry crowd. The same point is made to Joan Anderson by the headmistress when her son is bullied in school: 'I'm not giving you the whole picture; for every one of my black kids who's wised off there are at least three who have either kept quiet or even held out their hands'. So a split is proposed in the community to soften the hard edges of the antagonism: there are, after all, some black police officers to stand between the black community and the predominantly white force, and there are black children who know when to keep quiet. This is given as a state of affairs which precedes the contingent questions of social anxieties and the exercise of state power which might arise from any particular incident. Meanwhile, the institutional pressures ('powerful men who are trying to pass judgment on the police department') are fended off by deputy chief Hayes (played, significantly, by Glen Ford). When the lieutenant, Bramlet, asks how much his investigative team is going to have to yield to the pressure for 'an officer's head', Hays's reply is 'Not an inch, not a damned inch!' So the ranks close relatively smoothly from the beginning, whereas in The Jar this was something that had to be worked for.

The central incident in No Margin for Error is framed by two others, both involving investigations into shootings by police officers. The first (ei) offers an explicit link with The Jar: a young officer, Ross (Christopher Connelly, who played Triplett in The Jar) undergoes a probing inquiry of the kind depicted in the earlier film. He even reacts in the same disillusioned and defensive way as the character in the earlier film: 'I've been questioned until I can't even think straight, taken back to the scene of the shooting, sat behind a desk for days, had my picture on TV and yet I still have a lot to sweat out! I ask myself, do I really need all this?' This case is cursorily sketched in, as if to engage automatically a set of suppositions which The Jar worked harder to generate, as if in fact No Margin for Error has been made with a degree of confidence in the deposits left by its own genealogy, its history or popular memory. No Margin for Error builds in two new elements; guilt, rather than feelings of persecution, characterises Anderson's reaction to the shooting in which the girl is killed, and then there is the third incident, in which yet another officer shoots someone, but this time

the case is used to explore the definition and placing of sexuality more fully than was done in The Jar. It is surely no accident that of the three cases only this third has anything of a mystery about it, the only one about which the audience does not know the whole story from the beginning.

On hearing a TV news presenter tell the popular joke of the moment--'The most feared figure in the community is now a white male in his late twenties, who lives in the valley, played high school football and now wears the blue uniform of the city police'--Anderson mutters 'guilty' over his bottle of whisky. The anxiety identified by the joke is made immediately simplistic: questions of social control disappear into the apparent complexities of individual psychology. As he withdraws from his family, Joan (like Jeannie in A Question of Honor) tries unsuccessfully to reach him; 'I pray to Him that nothing should destroy us'. Finally though, it is not in religion that she finds some comfort, but in the advice of lieutenant Bramlet (Harry Guardino, the lieutenant in Dirty Harry). Joan goes to see him. ('He trusts you. I guess that's why I'm here.')

When he asks, 'How are things going at home?', she offers a bleak picture: 'There is no home. There's myself, there's our son who goes to school, watches television and goes to bed, and then there's a stranger who keeps going further into...God, I don't know where poor Jack goes these nights'. Again the dark continent of individual psychology opens up. Bramlet tells her just to 'be there' while the investigation, and Anderson's depression, run their course. This is crucial in several ways; it establishes that the family is not a separate place (Jeannie's family in A Question of Honor) into which Anderson could go for support (instead he goes into himself; psychology swallowing the social) but that it is instead a part of a larger structure. Bramlet makes much of the fact that Joan is a nurse, almost as if 'the wives', as he calls them, were special employees of the police department meant to 'be there' for their husbands. Bramlet puts Joan in position as one passive support of a 'family' structure larger than the home she describes. Finally just as Anderson is there to protect his son ('he's been under a lot of pressure since the shooting', Joan tells him) so Hayes (Ford) is

the benevolent father in the larger structure. This is precisely the strategy in The Jar, although here the benevolent authority is allowed to be located higher in the hierarchy, rescuing the group from the possibility of inertia; unlike Terranova, Bramlet does not mark the last line of defence. There is another, more remote centre of benevolent authority. (He never meets the uniformed officers but his remoteness creates a space for them to operate in). Indeed Anderson is explicitly looking for some kind of paternal reassurance: he goes to see the dead girl's father but is told, 'There's nothin' I can do to help you'. Instead it is a piece of brotherly advice from Ross that finally makes the difference. ('It must be the same for all of us, and yet somehow it must be different... maybe a man should come up with a verdict on himself': as if to draw him into the kind of resolution, the delicate balance of filial pride and obedience, constructed in The Jar). When, immediately after this, Anderson tells his wife 'maybe I'm turning the corner', the passive position to which Bramlet has assigned her seems to be justified. There is a fade and cut from a close-up of Joan, neatly contained in her starched

uniform, to another young woman, Gloria, with heavy makeup, a very low-cut flimsy blouse with obviously nothing underneath to conceal her generous figure, and a mane of unruly hair.

Gloria is the girlfriend of the victim in the third shooting incident and a hostess at a sleazy bar (when we first see her she wears a gaudy red dress to match the neon) frequented by Callender, the officer who shoots her boyfriend. On the several occasions in which we are shown the bar, its space is organised around the scantily clothed hostesses and dancers whom Callender eyes with evident pleasure. The 'secret' uncovered by the investigation into the third shooting is the relationship of Callender and Gloria, one of these women. (It is this kind of 'secret' as a structuring essentiality that Joe DeFalco refuses in A Question of Honor where the transition from starchy white to alluring colour is controlled by the one woman, thus resisting the good/bad split). By his involvement with an 'active' woman, that is one whose sexuality (as represented here) is self-evident, uncontained, Callender is expelled ('You break him', Hayes tells Bramlet) from the 'family' which finally embraces Anderson.

Meanwhile Anderson is back in action on the street, absolved of responsibility. Almost immediately he rescues a young woman from a gunman, symbolically righting the previous wrong. His penultimate scene has him adopting that archetypal image, gun in hand, face set self-assuredly (no more anguished self-questioning), proving himself again by protecting an innocent young woman, returning her to the mother, preserving the family. On being told about Anderson's success, Hayes nods in paternal approbation, 'I guess that's it'.

'It' all comes back (visually: throughout the film Hayes at home, in cosy cardigan rather than sterner working clothes, keeps taking 'phone calls to keep in touch and to pass on instructions) to Ford's performance as an organising force, the external mediator whose dependable solidity is the ideal towards which Anderson moves, from anguish to 'cool'. This is the Oedipal resolution which firmly aligns Anderson's internal mediation with Hayes' external mediation, a resolution constructed around Ford's unyielding ('not a damned inch!') performance:

Ford's icy glances represented a cold straightness, and even his unrugged humourlessness, adaptable for all kinds of melodramas and westerns, probably contributed to the actor's popularity with producers in the fifties, when he made thirty-two films. There's not really much interiority to the kind of man Ford sums up: the character's whole being is accessible once you've seen the clenched teeth and heard the quiet threat. And there's a real lack of color in the men he portrays best, which may explain why he's often cast as the beleaguered man of integrity who finds himself fighting a dangerous threat to society.⁷⁹

The Oedipal is, in all these examples, the terminus of reading, the 'truth' towards which the investigative structure points, but crucially it has been placed there in order to be found. It has been planted. There has been a frame. A (de)termination.

In his work on narrative structure Holloway identifies what he calls the terminating event, so-called 'because although it may well not be what comes in the very last place in the narrative (and so not strictly be terminal), it is indeed what resolves the narrative and finally determines its conclusion, everything that follows it being mere consequence and detail'.⁸⁰ Now it is necessary to emphasise something that Holloway himself leaves a little vague. As none of the 'events', initiating, reversing, terminating, or whatever, is being considered as somehow cut

free from the film, we are strictly not compelled to identify a single episode or moment which by itself can be seen to have this full terminating force. Although the initiating event does seem often to be isolable in this way, it is so only because the set el...ei tends to be small. Where el...et is a comparatively large set, its end term is best considered as representing that point in the succession of sets where (i.e. by which time) a stable configuration of elements appears to have been achieved.

Such a configuration frames the solution to the mystery, the apprehension of the criminal, the getting-the-story-straight, which is to say the vindication of the audience's major suppositions. The disruptive, the illegal, all that threatened or temporarily achieved the overstepping of boundaries, is held in place; not just in the film, but in the audience which the screen holds in seriality.

The 'frame' (in the criminal sense, established on the pictorial) operates in the imaginary space (superimposed on, and collapsing, the actual distance) between what appears on (simultaneously suppressing the sense in which it is actually 'on') the screen and the audience

to which it appears (the fragmentation of the description here expressing a real fragmentation which pretends to be anything but); a volume, as it were, erected on the flatness of the line of story-events, framing the (screen-)frame. So the terminating event is more than just an effect (stopping!) within the continuity of the narrative. It is more, obviously enough, than turning off the projector or TV set. But this 'more', though obviously there, is not in itself so obvious. Narratives do not simply turn off, and yet what other option can be open to them?

The answer lies, of course, in the fact that the audience does not turn on and off with the projector or TV set and the terminating event is as much in the audience as it is in the film, in what the audience makes of the continuities on the screen. Some care is needed here in the deployment of the available terms, such as cause-effect and initiative-response. The problem with a notion of continuity as achieved solely through a process of cause and effect is that it tends to be too rigid and mechanical to allow for the kinds of far-reaching and involved connections which are made so easily as a film is read without reducing what is witnessed to the level

of a game of billiards (A makes contact with B, therefore...). On the other hand it seems entirely acceptable to say, 'the initiative by one character directly poses the question of what some other character or characters will do'.⁸¹ The 'question' allows for the operation of something less fixed than the laws of mechanics. (This is not to say that the game is not, in the last instance, 'fixed'.) It also returns the audience to its actual place; poses for whom, after all? If there is a cause-effect relation it is between an event on the screen and the spectator's suppositions ('the question of what'), while the process of initiative-response better allows for the continuities as read among the characters and roles which interact in the film.

In what way are suppositions the 'effects' of narrative events? Returning to the rudimentary example of ei in Hustle, the dead girl found on the beach, it is entirely clear that this event is the cause of a major supposition due to some particular kind of background information brought to the event:

Every continuity-process is made possible by a combination, a collaboration between the prior member of the initiative-response or cause-effect pair, and the massed deposits which constitute the voluminous background to our reading.⁸²

Something like this begins to emerge:

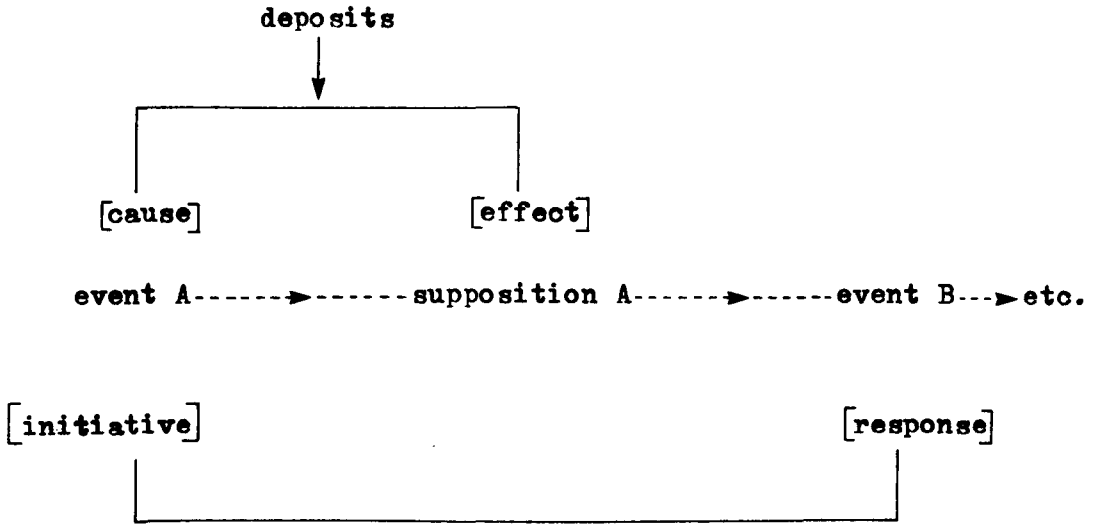

Fig. 53.

The same suppositions may keep recurring or they may be modified or replaced. At the same time we may suppose that the deposits will, as the film proceeds, be added to by the very specific information furnished through the narrative in question, and also that only certain elements of that background deposit will be re-activated in a particular instance. Moreover, given the transient nature of the film experience, at any one moment the film up to then will have itself become part of the background, so to speak. So continuity will partly be through the progressive re-activation of deposited information, both brought to the film in the first place (also generating, therefore, pre-suppositions) and

more specifically, provided by the film itself. In short, narrative events may be thought of as causing suppositions by re-activating and channelling deposited information in such a way that it points in particular directions, prescribes certain limits for subsequent events, certain possible sequels, finally a termination. Supposition is precisely the recognition of these, the sifting of likelihoods and inevitabilities out of possibilities. Before an inevitability has been actually fulfilled its 'presence' is an effect.

The long-extending continuities within and among the major strands of any narrative are, therefore, derived essentially from the process of depositing and re-activating information and from the channelling of this information in order to generate supposition. (Holloway also uses the terms 'confirming' and 'calling in' for 're-activating' and 'channelling'; the latter pair seems just a little more apt in its suggestion of a semi-automatic narrative machine). So events, deposits, re-activations, channellings and suppositions collaboratively constitute narrative complexes. (Holloway cautions against any ambition to analyse, exhaustively, a complex

of this kind: 'I cannot believe this impossible in principle, but the inextricable density of the overlapping, and the complexity of indirect continuities which result, are reflections of its at least decisive difficulty in practice'.)⁸³

It is precisely because we are dealing with such complexes (and the present work has been shifting across the levels of such complexes) that the Oedipal can be understood to be operative around the terminating event, that is around the point by which a terminating configuration of elements, a containment of disruption, appears to have been reached. The Oedipal configuration operates within a narrative complex where it effects, as has been seen, a displacement from the other, the embryonically political, geometry of desire based on seriality. In the end, the narrative complex masquerades as an Oedipus complex.

The Oedipal as a fictive effect is not always so diligently hidden (in order to be discovered) as it is in the examples interpreted here. There is in Apocalypse Now, for example, (and this is, after all, a detective story too, with its 'hard-boiled' narration, its mystery, its quest) an attempt to know its own secret.

It carries on a running joke at its own expense: the piles of books in Kurtz's hideaway, and, even more obviously, The End⁸⁴ which, from the beginning, broods over the soundtrack while never quite coming to its own explicit conclusion. But it is a knowingness which is finally too coy to shake the structure. It falters over the attractive glossiness of the horror, the excitement. 'I wasn't even in their fuckin' army any more', says Willard, but of course he is; he can never (and the audience must know it) escape from the fact that it is being in this army that puts him here, at this moment of (supposed) revelation, instead of living the sameness of American suburbia. The camera is too insistently admiring of the spectacle, the exoticism, the baptism of fire, the Oedipal drama.

Hustle, however, manages a more involuted reflection on its own processes.* In bed with Nicole, Gaines stares fixedly as a white whale plunges across his television screen in a scene from Moby Dick.⁸⁵ He is 'stoned on fatigue' and tells Nicole that he has faced his white whale that day in a 'butcher's shop'. The 'butcher' is the supposedly rehabilitated killer who goes on a bloody rampage in a factory and, when

* processes introduced above, pp.272-83

cornered, demands to see Gaines. When the confrontation occurs, Gaines brings the gunman down with two shots and then empties his gun at close range into the body. 'Those son-of-a-bitches never die', he murmurs by way of an explanation to his partner and then staggers off in a state of nervous exhaustion. That evening in an interlude of boozy camaraderie with Louis, they talk about their 'heroes', among them Bogart and John Garfield, now consigned to the late show on television. 'You know what's on the late show every night this week?' asks Gaines. It happens to be Moby Dick which leaves Louis singularly unmoved and wondering at Gaines' insistence that he should watch it. 'Because of the whale', Gaines persists, 'Because of that friggin' white whale...every man's in search of a white whale and when you find him he usually kills you'. 'Oh yeah?' Louis mocks gently, and then 'What are you going to do about Sellers, Phil?' Gaines is indifferent. He thinks he has already met his whale, emptied his weapon into it: 'Nothin' : Man's in a swimming pool with the Hollinger girl. There's no crime there. It's over, finished.' He goes home to Nicole and the re-run of Moby Dick.

But the drug squad puts Sellers back on his desk, in the form of a tape carrying the 'phone call which coincided with the murder of the three men outside the union headquarters. (The call-box used by Sellers was being monitored as part of an unconnected narcotics investigation). Meanwhile Marty Hollinger has found out that his daughter was with Sellers on the night of her death. Investigating further he is badly beaten and his wife sends for Gaines who tells him that he is dealing with 'very organised people' and adds, with a Hawksian flourish, 'an amateur like you can't go up against professionals'. Hoping to protect the bereaved father, Gaines offers a deal: 'I'll find out everything there is to find out about your daughter's death--everything--but you've got to stay out of it'. The promise made, Gaines, almost despite his own intentions, gets drawn vertiginously towards Sellers. Bits of a pattern are beginning to fit together; he discovers that Marty was cuckolded when he came back disabled from Korea, that three year old Gloria walked into her mother's bedroom to witness the scene (in fact the man was probably her actual father), that years later she would be repeating it endlessly in porn films. Gaines

holds all of this together with some obsessive sense of lost innocence; of old soldiers (older even than he means: Ben Johnson is memorable as Tyree in She Wore a Yellow Ribbon⁸⁶), of a time when attorneys didn't wear expensive jackets, of the fatherly old Romans he had once met on an international assignment, of Arty Shaw and days when 'the game seemed a little more balanced'.

Hollinger does not take Gaines' advice, however. He goes to Sellers' house and murders him. When Gaines and his partner arrive on the scene, Marty insists, 'I want my day in court... country owes me that'. Gaines' cynicism finally surfaces:

'What country? What court? Don't you know where you're living, Marty? Can't you smell the bananas? You know what country you live in? You live in Guatemala with colour television. Guys like you ought to die in combat... You don't understand, do you Marty? You're not supposed to kill important citizens...'

'He killed Gloria'.

'No he didn't. He killed a lotta other people. He didn't kill your daughter. Your daughter drowned on the banana river'.

But even as he berates Hollinger, Gaines is tampering with the evidence to make it look like

self-defence. To complete the picture he shoots Hollinger in the arm with Sellers' gun. Louis is hesitant (understandably); 'I never thought I'd do this for anybody'. But Gaines insists; 'You're not doing it for anybody, you're doing it for a nobody'.

The die is cast. Leaving the scene to meet Nicole, Gaines stops at a liquor-store, stumbles into a hold-up and is killed. The terminating event refuses to hold everything in place. The bad father is destroyed and the good father is put back in place by the dutiful son, out of nostalgia as much as anything. It is only a gesture because this is a world in which the bad fathers have the power. (Nostalgia is a crucial factor in the way Ben Johnson functions within the overall system of the film, as a Fordian stalwart, a deposit recalling, as in The Last Picture Show, there again paired with Eileen Brennan, a time when 'the game seemed a little more balanced'.⁸⁷) Leo (a jocularly appropriate name, of course, particularly given Gaines' comment about how difficult it becomes to tell Christians from lions) is one of the 'important citizens' a lawyer among those 'very organised people'. It is this institutional level (where Leo Sellers is doubled by police

chief Santoro for whom also Hollinger is a 'nobody') that Marty Hollinger, the 'nobody', has so foolhardily railed against. Removing Sellers does not change the smell of bananas. The political 'dirty picture' is not finally and completely displaced by the sexual. Louis makes one final attempt to do this, just before Gaines' death: 'You killed Leo, you used Marty just like a hit-man, right?' After all, Leo was one of Nicole's most powerful and demanding clients and Gaines was beginning to draw his own 'dirty pictures' (reinforced by the films of Gloria). Nicole's special telephone service puts the audience in the position of having to draw their own. But Gaines will not let the displacement complete itself: 'Wrong! I'm the one that tried to keep the lid on, remember'. For Gaines the final confrontation is not taken up entirely into the Oedipal (just before Marty's obsession takes him to the strip-club where he 'sees' his daughter, we see Gaines sharing a dirty joke with a barman; a marked contrast which emphasises the different levels to which the sexual is assigned by the two men): the lid is off but what is revealed is not only the Oedipal configuration but also 'Guatemala with colour

television'. It is, after all, on television that Moby Dick has his day, time and again. Gaines refuses to blame Sellers directly for Gloria's death, the major supposition with which the film has worked throughout. This would be the neatly ordered, the containing, the properly policed termination, allowing Moby Dick out of the television and into the banana river, like Kurtz in Apocalypse Now (or even Kane, shaven headed and equally monstrous, lording it over the monkeys). For refusing it, Gaines must provide his own terminating event.



From its dream-like image of a woman drifting in a pool atop a skyscraper, a woman particularly marked as an object of the look by the frame within the frame provided by the telescopic sights, Dirty Harry proceeds by way of looking at several women, none clearly identified as individuals and therefore constituting a kind of undifferentiated 'woman', to making the wholeness of that first image something different. Where

at first the threat comes from the gun through which the look is directed, progressively the problem is shifted to the other end of the axis as well so that Harry Callahan's function is to restabilise both positions. The problem is simply that the aggressive look is met by nothing other than a striptease, a display which offers here a threat of its own and must, therefore, also be contained.

The change is rehearsed in one brief sequence which has no other purpose in the narrative than to begin to make the woman's image itself a problem. Harry follows a suspect (it turns out to be a false trail) into an alley and when the man enters a building Harry perches on garbage cans to peer through the window. Inside, the man has met a woman. From Harry's point of view (established over the shoulder) the man can be seen about to remove the woman's poncho. She is obviously naked underneath but before Harry's view is completed he is dragged into the alley by a group of angry locals who accuse him of being a peeping-tom. There are two subjective shots during the ensuing brawl. In the first an angry face in close-up stares down at Harry and shouts, 'Lousy peeping-

tom!' In the second a large fist slams into the subjective position. The look is punished but as Harry collapses under the blows (to be rescued a moment later by his partner) the audience is offered a shot of the woman drawing the curtains aside and standing naked at the window to watch the scene below. This is a privileged viewpoint; none of the men in the alley is looking up at that moment. So the first look is interrupted and the woman as object of the look begins the strip (without the conventional props, decor and preparation which circumscribe and exorcize it) which will become increasingly threatening (through other women, but without much differentiation).

During a roof-top surveillance Harry watches a building through binoculars. At one window a young woman is walking around in black underwear and boots, viewed subjectively from Harry's position. She disappears momentarily and then re-appears with nothing on but the boots. Harry stares intently, obviously enjoying himself. His voyeurism is, however, defused when the woman opens her apartment door to admit a couple whom she greets familiarly. Harry's look has not been invading her privacy in the way he supposed.

What he has been stealing a look at is in fact undisguisedly on show. Moments later the exchange between look and display becomes an exchange of shots as the sniper appears on the roof above the woman's window. And again the aggression is turned back against Harry. His apparently secure position of surveillance is torn apart by the sniper's machine-gun fire. So when Harry's look encounters a woman her display of her own body is drawn into a pattern of threat and aggression. The ambiguities around the woman at the window (innocent object of the aggressive look or threatening display?--the film insists on this binary opposition) are immediately drawn into the central event of the narrative, the kidnapped teenage girl, Ann Mary Deacon.

Harry's lieutenant is looking at glossy colour photographs of her, an attractive girl in a short dress, flirting with the camera; we see over his shoulder as with Harry in the alley. Harry's partner reads aloud from Scorpio's letter as Harry in turn looks at the photographs, 'Red panties and bra, nice tits'. It could be the young woman Harry has just been watching; she is revealed, as it were, behind the display of the photographs. And Scorpio has sent three objects with his letter: the bra, a lock of hair and a

tooth which is shown in close-up from Harry's point of view, a bloody knob wrapped in a handkerchief; 'pulled out with a pair of pliers', according to the lieutenant. Revealed but not threatening, she has been put in her place as victim by having this pathetic object wrenched out. That is all there is to it, for Harry: 'You know she's dead don't you?' But all the investigative machinery of the police department now goes into action, as if in her place as object, as unthreatening, as incomplete, the woman allows everything to run smoothly, the way it should, with a story getting straight. It is essentially the story of Harry's power, of what he has where the woman has only the insignificant little object which can be torn off.

It culminates with Harry torturing Scorpio who squeals and turns to jelly in the middle of an empty stadium. We look up again at the long barrel of his gun looming powerfully as the encircling ranks of empty seats emphasise the movement from impotently spectating seriality into this single image of potency. In the next scene Ann Mary Deacon's naked body is brought up from a hole as Harry watches. The pattern is complete.

But the legal system is mis-matched with Harry's Law. His methods have cut through the established procedures and in court 'all evidence concerning the girl, the suspect's confession, all physical evidence would have to be excluded'. Yet this is all that counts for Harry, the 'physical evidence', the evidence of the gun and the girl, which is to say the binary opposition of presence and lack:--Harry (the gun is finally his, although the legal problems arise around the admissability of Scorpio's gun as evidence) and the girl who is marked as lacking by the severance, the removal of the tooth after she has been stripped (no vagina dentata here).

When Scorpio is released, Harry sees two more women. They are both young and blonde. The first is a nude dancer in a bar where Scorpio goes. We see her stroking herself, pouting her red lips, and then the camera tilts down to Scorpio. In the next scene Scorpio pays to be savagely beaten in order to frame Harry for harrassment and brutality. There is the same subjective shot into a clenched fist as in the scene where Harry is beaten in the alley, the same latent connection between the threat and the woman's display. Harry meets the other young blonde. She is the wife of his now hospitalised

partner (shot by Scorpio before his first capture). Her long hair makes the connection with the dancer, but here it is tied back neatly and she wears very little makeup. She is neatly dressed, reserved but clearly concerned about her husband and the stresses which his work is putting on them both. Harry is insistently respectful. 'No class', she muses despondently about her fears, a strangely inappropriate remark but it allows Harry to mark his respect. 'Don't ever say that', he insists, almost angrily. He then tells her about his wife, killed in a road accident (like Bronk's)*. The contrast between these two women, the dancer and the wife, is organised around the film's project to put woman in her place. The nude dancer threatens to set the whole process going again, to revive the threat which Harry has already dealt with. The wife is the counter-balance, knowing her place, the place which endows her with her 'class'.

The introduction of the familial model precipitates the film's climax. Scorpio hijacks a school bus. Harry has to play the role of father, rescuing the children, returning them to their place; 'I want to go home to my mother', pleads one of them, time and again. 'I'm going to kill all your mothers', Scorpio tells them,

* Bronk, see pp.355-61

and then suddenly there is Harry as if from nowhere, standing impassively, his gaze fixed on Scorpio, the father come to protect his family. A protracted chase has the inevitable culmination: Harry's gun literally blasts Scorpio and the hostage child apart. With Scorpio sprawled beneath him, Harry repeats his earlier ('This is the most powerful handgun in the world') monologue and when Scorpio reaches for his own gun Harry kills him. His body drifts in a pond, like that of the first victim.

It is largely the stability of the familial structure and Harry's role in relation to it that allows the Janiform Americanised Fascismo of the cycle (four to date). Finding the 'system' irredeemably weak in the first film, Harry can, without any apparent risk to the commercial momentum of the product-line, execute a turnabout (somewhere on the way surreptitiously retrieving the badge he throws into the water with Scorpio) and announce, 'I'm afraid you've misjudged me'. His remark is addressed, in Magnum Force, to the death-squad of adroit young Vietnam veterans whom he suspects of being just the tip of an iceberg, a 'whole sub-organisation within the police force' dedicated to circumventing the courts and dealing out rough justice.

Magnum Force establishes the same kind of opposition as its predecessor between the wife/mother and the other woman. An attractive girl with shoulder length blonde hair throws off her blue bikini in a crowded pool (she is apparently, like Gloria in Hustle, a mobster's amusement) just before a massacre in which she is the first to be shot. In the next scene Harry is watching a TV report of the incident. He is surrounded by children; clearly he is a guest in someone else's home. Their mother comes in and she is strikingly similar to the girl in the pool; the same colour, length and style of hair, and she wears a blue blouse. It becomes apparent that she, Carol, is the wife of a colleague. The scene is cosily domestic but Carol's husband has left her and Harry is playing the role of Platonic shoulder (he calls her 'sweetheart') and father-figure to the children. 'Do you know that he was living on North Beach with some nude dancer?', asks Carol, and the connection is made with the nude dancer in Dirty Harry and with Norma, the wife in the earlier film. The police death-squad is to be implicated in this disruption of the family.

'All our heroes are dead', they tell Harry when he is on the verge of uncovering them, and therein lies a crucial difference constructed between their violence and his, a difference on which rests Harry's success as a phenomenon of dominant cinema in the seventies. The death-squad is a tightly organised group (so tight that other officers suspect them of being homosexuals) of interchangeable functionaries, their helmets and dark glasses emphasizing their anonymity, willing to sacrifice any of their number in the interests of their vigilante project: 'There's a lot more where they came from', says one of their organisers. But it is finally the father they kill: Carol's husband Charlie (Mitchell Ryan) who has discredited the father's position and so seems to justify the loss of faith in the authority of 'heroes'.

Harry prevents the audience sharing this loss of faith and defends the stability of the structure which Charlie has momentarily destabilised. There is a diegetically inexplicable shot of a framed photograph of Charlie in uniform in the sequence at the beginning of the film which reprises the ritual dressing for work of the motor-cycle patrolman (himself a Vietnam

veteran) in Electra Glide in Blue; there is no reason why one of the young officers should have such a photograph (in the novelisation⁸⁸ it sits by the TV in Carol's house) but it makes the killing of Charlie into a distinctly Oedipal act. (It also strengthens the link with Electra Glide in Blue in which Mitchell Ryan plays Harv.) So cutting across the tortuous progress of the narrative (burdened with variations on scenes from Dirty Harry) is a simple pattern: the nude dancer tempts Charlie to abandon his role as father (a position of 'natural' potency which the liberalism of the 'system' has also threatened, or so we are told; 'These days a cop kills a hoodlum on the street, he might as well just dump the body someplace, because those snot-nosed young bastards down at the DA's office will crucify him one way or another'); as Harry discovered in the earlier film, aggression re-bounds from the woman's display of her body and in this case Charlie is killed by one of the death-squad who has just shot a naked woman, her body tumbling through a window being watched with binoculars by two detectives (explicitly recalling the scene from Dirty Harry where Harry is watching; there again a policeman is killed).

And Harry again works to redeem the father's position, as himself a kind of surrogate father, his wife's death preventing him from actually taking on the position and perhaps, we are led to believe, forcing (freeing?) him to live it symbolically as an external (or as Girard would say, exogamic) mediator. (The novelisation of Magnum Force fills in a slightly different background: Harry's wife is a 'svelte body' whose liking for men in uniform comes from the fact that her father is an Admiral. She isn't killed; their marriage is a sudden whim which they both regret. In this case Harry's wife does not represent the good woman but the bad and he endlessly repeats the severance.)

It is a singular role, in contrast to the vigilantes who are so much a group that they are suspected of being homosexuals; a revealing equation. Harry is a loner, self-sufficient. This is what makes him so (paternally) dependable. Something of this is suggested by Peter Maas in his book on Frank Serpico (called by Time, 'one of the tiny untainted minority'⁸⁹): 'One of his favourite movies was High Noon, the brilliant portrayal of a beleaguered sheriff who almost singlehandedly saves himself and his town from

a band of killers'.⁹⁰ Harry's final gesture in Dirty Harry, throwing away his badge, is of course an unmistakable quotation from High Noon.

Harry's persistence as a lucrative commodity rests then on his successful embodiment of an anachronistic conception of the power structure, or, more accurately, of the insertion and maintenance of sovereignty in social relations. As an embodiment it undoubtedly derives some of its authority from the discursive strand, that of the beleaguered lawman, which High Noon re-energised (by questioning the values of the town which he defends and thereby marking a transition from prototypical Westerns like Dodge City⁹¹). But the Leone films were perhaps more important in the way in which they rehearsed a particular kind of performance, a refinement and re-direction of something already present in American film, and then returned it fully re-formed to its native context.⁹² Eastwood's performance as Harry is a second generation 'radio' style, a stripped down version of performance as non-performance (which Dyer⁹³ links to the style of American radio performers in the 20s), an extreme version of the so-called Hollywood studio style; 'the myth persists that Hollywood actors

of the thirties and forties never exactly acted'.⁹⁴ A few 'personal' mannerisms overlay a stereotypic appearance; from Bogart's grin/grimace personalising the stereotyped 'heavy' to Eastwood's screwed-up eyes personalising the beleaguered lawman (and before that, the outlaw) it is a matter of fulfilling expectations (those of the audience essentially, but also therefore of the producer and/or the studio). Typically, cues as to how to read the central performance are provided by cutting to other participants in a scene, so that we read Harry's impassive figure at moments of narrative tension via the responses of others, such as the succession of his victims, sprawled and squirming as he stands over them. Even more than Cooper (High Noon) or Henry Fonda (in The Tin Star⁹⁵ for example) other sometime exponents of the minimal performance, Eastwood's acting seems 'convincing' because in place of range and difference he offers predictability, based on a small repertoire of distinctive gestures and vocal inflections. The hardening of this style into something beyond what Cooper, Fonda and others (such as Glen Ford) did with it, effected largely through the Italian Westerns of which this is one of the most distinctive features (almost to the point of self-parody), can be

better understood perhaps in relation to developments in the other major tradition, that derived from the Actors Studio⁹⁶. (Stanislavski's influence in America dates from the twenties which makes this a roughly parallel tradition with the 'radio' style.)

Jameson characterises Pacino's performance in Dog Day Afternoon as a 'second-generation reappropriation'⁹⁷ of Actors Studio methods (the Method, so-called). Its energy elicits the audience's support against the impassive FBI agent, which is to say (although Jameson does not consider it in quite these terms) against the 'non-performance' delivered by James Broderick, whose presence reminds us that the style originally derived from broadcasting ('instantly recognisable characters, recognisable that is both as types and as individuals...a style of performance that seems more like day-to-day interaction'⁹⁸ = avoidance of excess to the point of blandness) has returned to it as a kind of 'TV studio style'. Eastwood managed to redeem the minimal performance at precisely the time when its extreme form seems better suited to depicting the impersonality and anonymity of a post-individualistic power structure. The Man With No Name exemplifies this sleight of hand: anonymity turns back into individualism.

In the 'Dirty Harry' cycle the male body becomes virtually monumental before a subservient camera. Eastwood's minimal performance offers the male body as a solid boundary, its surface undisturbed by desire. Pacino's performance in Dog Day Afternoon goes to the other extreme; the body seems in danger of bursting apart, it sweats and darts about, it threatens to disintegrate. It takes the principles of the Actors Studio (crudely 'to find the things which will relax you, unlock you, and let all of that private emotion come out'⁹⁹) to an extreme (on the basis, perhaps, of an audience's familiarity with Stanley Kowalski rather than Stanislavski). We find this contrast, quite clearly in fact, within Magnum Force in the difference between Harry and Charlie. Mitchell Ryan's performance as Charlie (recalling the final stage of his performance as Harv in Electra Glide in Blue) is quivering, nervous, edgy, and when he meets Harry in the police car-park at night his instability is met by a stony, expressionless stare. The unreadability of Eastwood's look here is precisely the point; there is nothing coming through from below the surface whereas in Charlie's case everything is threatening to come through.

(Rod Steiger, who for a time epitomised the Actors Studio performer and plays another Charlie in On The Waterfront, has emphasised this quality of bodily disruption or disturbance in the approach. On his playing of Napoleon: 'Napoleon was afflicted with primary cancer of the stomach, but also by partial blockage of the urinary canal, perforated ulcers, a liver disorder, and hemorrhoids. Out of this came the conception of a man whose body was decaying...'¹⁰⁰ One can hardly imagine Eastwood approaching any performance in such terms.) In Magnum Force where Eastwood's gun extends the impermeable, monumental body, Charlie turns his gun against himself, threatening to rupture his own body from without as well as within; Carol tells Harry, 'Yes, I saw him last night. He wanted to see the kids and then he started playing a little Russian roulette with his revolver'. (Michael Cimino, who co-wrote this screenplay, revives the idea in The Deer Hunter where the Russian roulette expresses Nick's gradual disintegration.)

Tony Tanner traces, through a number of American novels (including Naked Lunch), the fear of losing the solid boundary of the body: 'Clay, jelly, jelly-fish--what this image cluster suggests is the dread of utter formless-

ness, of being a soft, vulnerable, endlessly manipulable blob, of not being a distinct self'.¹⁰¹ Eastwood's performances offer instead what Reich called, disparagingly, an individual who is 'characterologically armoured'.¹⁰²

The monumental presence of the male body is made the primary organiser of the familial model which allows the imaginary insertion of sovereignty in a position which we know to be impossible. The officers on the street in Police Story are always looking over their shoulders nervously for 'shooting teams' (departmental watchdogs, investigating the investigators) and TV cameras, the visible evidence of the location of actual power at the institutional level. In the episodes considered here, this insecurity is dealt with by imposing the familial model in such a way as to constitute a family of 'ordinary' police men. At the end of Police Story : Countdown¹⁰³ the fatherly lieutenant tells two mobsters to stay away from his sergeant: 'Look, I want you both to understand that if Joe La Frieda here dies of anything except old age, I'm going to consider it a family matter and there are six thousand people in Joe's family'. But, as we have seen,

this 'solution' is potentially ambiguous. In Police Story : The Jar the ambiguities are controlled by a variety of devices, including the split-father, but it reaches an uneasy conclusion (and is interesting for that very reason); the compulsive way in which the body of the victim has to be made to disappear raises questions about whether the male group's internal loyalties have aberrant effects (in Magnum Force this turns back against them as an accusation of homosexuality). In Police Story: No Margin For Error the margin for error in the devices employed in the earlier episode is narrowed by re-introducing the strong father played, in the minimal style, by Glen Ford.

8.3 Authority/performance

James Cagney's performance in A Lion Is in the Streets insistently proclaims 'I'm Hank Martin' (and 'I'm Cagney' too) and draws the political implications of the fight between cotton-growers and owners into a space defined by representations of sexuality, of Hank/Cagney as dominating, competitive, tough, controlling the contradictions which are displaced from the political arena into the tension between the 'good' and the 'bad' woman whom he holds in place. Hank's working-class toughness both champions the poor for his own ends and, by the displacement into sexuality, partially endorses the right to power of the strongest. It is a thinly disguised 'humanization' of the principles of Louisiana's governor Huey Long (via All the King's Men¹⁰⁴ which is, however, sourer and more cognisant of the roots of dictatorship). It uses the star's performance to embody all the values of an individualist ethic bordering on fascism and naturalises them in an area of the personal, of sexuality which engulfs the social and political.

From its opening shot, tight in, low angle, a towering white-suited figure gesturing expansively, and its second shot, cutting to a

high angle, the crowd circled around this central figure, The Life and Assassination of the Kingfish¹⁰⁵ explores Huey Long's ambition to be larger than life, to be 'of the people, but set apart', as the Kingfish enounces his project. But, from the beginning too, this ambition is marked by failure; the film begins in 1935 on the day Huey Long is shot and tells his story retrospectively from there. Much is made of the fate of the assassin at the hands of Long's bodyguards; 'Nobody I know, not that you could recognise him now'. As played by Edward Asner (more like Broderick Crawford in All the King's Men than Cagney), Long's vaulting ambition is inextricably tied to his physical presence, heavy, domineering, the omnipresent white suit imparting a statuesque quality and emphasising the defilement wrought by the assassin's single bullet ('was there blood on his suit?', his wife asks), whereas the assassin's body is torn apart: 'They must have pumped sixty bullets into him...It reminded me of Verdun'. It is as if the destruction of the assassin's body is in punishment for threatening the massive, powerful, self-sufficient, bodily presence of Long. The film works two operations on this presence, as the doctors simultaneously operate on Long, trying to restore his body to its fullness.

In the political sphere, Long's thrusting presence is gradually exposed as an obscenity while, separately, in the familial sphere it is traced back to 'natural' beginnings; part of his 'story' is reconstructed through his wife's memory and in this way Long is offered as understandable.

Praying with a nun in the operating room, Long murmurs 'deserving of all my love', and a sound overlap carries his words across a cut to the corridor outside where, from a low angle, the heavily armed and jackbooted state troopers are marching; there is a jump throughout the film between the private and public spheres across which 'love' translates into authority in one but not in the other (his 'love' for the common people being suspect, for example). Just when someone in the hospital refers to Long as 'a future president' a cut to outside introduces his wife Rose arriving, not at all an aspiring First Lady.

She is small, frail, girlishly attractive with wispy fair hair, and the camera lifts her out in medium and close shots from the confused throng of bystanders. As she waits she remembers; a long dissolve sliding her part of the narrative

back through the confusion, from the public sphere in which Huey's ambition is mirrored by hangers-on, to their first meeting when his brash confidence is tempered by her shyness and charm. It is an idyllic scene at a small-town fête where Rose uncovers a trace of self-parody in Huey's act, something entirely absent from his public performances, but he admits to her, in his Southern drawl, 'I'm never entirely serious Miss Rose, but I'm never entirely altogether frivolous either'. Courting Rose, his insistent talking drives her mother from the room and without stopping for a breath he embraces the girl passionately; his ambition, his voice, his stocky body, even his look ('never write what you can 'phone, never 'phone what you can talk head to head, never talk what you can nod, never nod what you can wink, never wink what you could look') bound together implicitly in a straightforward representation of aggressive sexual identity. 'You can't stop Huey, but you know that better than anybody', someone remarks to Rose. She remembers Huey in bed, talking non-stop about his plans. Cuts between beds span the years, like the breakfast scenes in Citizen Kane, the setting becoming progressively richer and Huey more dictatorial.

What is particularly interesting is that whereas A Lion Is in the Streets slides together the two arenas in which the central male performance operates, The Life and Assassination of the Kingfish progressively distances them ('roads and bridges, they're his children', says Rose). Somewhere in the background (the details are never clear) of his life outside the family, there is an attractive woman who sees to Huey's pleasure, her coquettish style, when she is glimpsed, contrasting with Rose's homeliness. This woman's fleeting presence is subtly echoed in the press-room in the hospital where the reporters trying to get their stories straight take no notice of a female anatomical dummy being discreetly veiled in the background. The film refuses to compromise the political coordinates of its 'story' by taking this conventional bait.

The essentially phallic sovereignty embodied in the central performance is questioned by the distance which grows between the personal and the social, the sexual and the political, a distance which performances like Cagney's work to elide. The distance is at full-stretch (the fullest allowed here) in the final scene when a

supporter pleads with Long at his death-bed to reveal the whereabouts of 'campaign funds' which have gone missing; Rose sits gazing detachedly off through the window.

This is not to suggest that The Life and Assassination of the Kingfish is radically challenging to the 'patrocentric' justification of authority. In fact 'Roosevelt' is constructed by the film as a distant but distinctive presence; 'Roosevelt claims I'm some kind of a fascist. The truth of it is, and he knows it, that I represent the people of this country. I am the United States.' It is excess which is made evident here and which the film questions but 'Roosevelt' marks the site of a benevolent, restrained and restraining, fatherly re-appropriation of the same kind of sovereignty. It is not the institutions of government which are finally set against Long but the off-screen 'Roosevelt'. It is moments after his claim to 'be' the United States that Long is shot, as if the challenge to 'Roosevelt' somehow draws down a final judgment and sentence. (Long hints that the president is planning to act against him; 'What kind of proof do you want, my dead body?')

'Roosevelt' is constructed as more symbolic than real; he appears in name only and Long fears the name in an almost paranoid way, as a spectral power, even as he imitatively aspires to that position.

James Roosevelt has pinpointed the element of nostalgia that accrues to his father's thirteen years in office (longer than any other president): 'In the wake of Watergate, we may never again trust a leader as most of the people of this country trusted him'.¹⁰⁶ And his brother Elliot is even more insistent: 'I believe that April 12, 1945, when Father died, marked the day when morality in government began to pass from the picture. The downhill road carried us into Vietnam and the abyss identified as Watergate'.¹⁰⁷ What is important here is not to assess the accuracy of such sweeping claims but rather to recognise them as symptomatic. That both James and Elliot had books about their father published in the mid-seventies suggests that these claims are rooted more in the climate of discredited authority than in any properly reasoned historical analysis of Roosevelt's actual 'morality in government'. When the father, the proponent of simple virtues, is written out of the long-running television series The Waltons

at the end of the decade, it is presented as part of a changed America, wrought by World War II and Roosevelt's death. (A convention of the series is that every episode ends with the family saying goodnight to each other on the soundtrack while the lights in the house are seen going off; on this occasion they say instead, 'Goodnight, Mr. President'-a surfeit of sentimentality possible presumably because of Roosevelt's nostalgically enhanced stature for post-Watergate audiences). The immediate period of crisis in authority in the mid-seventies sees the world of The Waltons centred on the father with Roosevelt behind him symbolically; only when the crisis is passing or being displaced in various ways does the series offer World War II and Roosevelt's death as its own positive recuperation of Vietnam and the fall of Nixon.

The contrast between the excesses of Huey Long and a 'Walton-esque' reappropriation of Roosevelt as the last good father is revealing (and within the kind of condensation effected by presidential 'images' there is also Teddy the Rough Rider--'my father followed in his footsteps',¹⁰⁸--who was 'the final distillation of the Western experience',¹⁰⁹). It is in terms of

excess that Elliott Roosevelt depicts Long ('he read recipes for frying oysters into the Congressional Record'¹¹⁰) and recalls an occasion on which he used his straw hat 'to whack Father's knees by way of emphasizing a point. Father kept on smiling...'¹¹¹ It is a contrast which can be revived in the seventies, when the sons' books and the film of Long's career coincide, to effect a delicate separation of excess (the politician who went too far) from a more restrained paternalistic authority (like that of The Shootist).*

What happens when Long is discredited for his excesses in The Life and Assassination of the Kingfish is that the symbolic mediator, 'Roosevelt', is a kind of presence-in-absence and Long is forced to vacate a power structure which is not itself discredited because the symbolic mediator (in this case also a potential external mediator--he might actually appear, unlike Amadis or Christ) holds it in place. Long vacates the paternal position but the position itself is justified by the absent father for whom it is reserved. Whereas in Seven Days in May the president (Fredric March) could be physically present and at the same time

* see pp.70-71

acceptably paternalistic, when the idea of a right-wing plot to overthrow the government is revived in the seventies, in The November Plan¹¹² it is again the absent-presence of 'Roosevelt' that is deployed to counter it. Instead of an obediently filial army officer, the plot is uncovered by a cynical private-detective (played by Wayne Rogers, familiar at the time as the irreverent second lead in MASH, the television series) who tells his client, Mary, that the police work for the wealthy backers of the planned paramilitary coup, 'Not for people like you and me'.

Mary: What are you Jake? You think all that's important is surviving. You're more than a survivor aren't you?

Jake: Forget about me. Survivor's a guy who just hangs on, a guy who's not having any fun.

Mary: You enjoy it?

Jake: You bet. Every now and then I can steal a little meat right out from under the lion's paw. Hey listen, they call LA the city of the angels. Well let me tell you something, all the angels left this burgh about twenty years ago. It's crooked and corrupt, and it suits me fine.

Mary: You don't give a damn about anybody but Jake Axminster. You lie, cheat, steal and if someone pushes you, you just push them back a little harder, huh?

Jake: So hard they'll never forget it!

Mary: It doesn't have to be that way Jake.

Jake: Well you may decide that in your own mind, Mary, but that's the way it is out on the street.

This is the position of a typical internal mediator to the point of caricature; the rebel without a cause (except himself), remote from organised authority. If the 'system' can be saved by such a man then it must be worth saving.

From A Lion Is in the Streets to The Life and Assassination of the Kingfish, from Seven Days in May to The November Plan:* the changes are complex but explicable in terms of the relationship between styles of performance and forms of mediation. The contrast between the styles embodied by Eastwood and Pacino may be thought of as marking a distinction between 'external' and 'internal' performance. The 'radio' or 'studio' style has led to the kind of performance which emphasises the surface, the body as self-sufficient, complete, undisturbed from within (and usually, therefore, a male 'toughness'): the external performance. The influence of the Actors Studio has led to an emphasis on disrupting the surface, insufficiency, incompleteness, disturbance (often, therefore, making 'toughness' a matter of ambiguity, of self-questioning): the internal performance. An external performance in the position of external mediator (Raymond Burr as Ironside, for example, where the physical

* see pp.237-50 (Volume 1)

disability is cleverly used to emphasise his toughness) is acceptable at a time when sovereignty at the institutional level is widely unquestioned. A crisis in authority, however, will tend, on the evidence, to shift the external performance into the position of internal mediation. This occurs with Baretta, for example, where the institutional context of his role is pushed into the background, and in The November Plan where the whole government of the United States is upheld by a cynical down-at-heel private-eye, played with hardshell 'toughness' by Wayne Rogers, the position of symbolic mediator being identified with Roosevelt, in nostalgia (the whole film is pervaded by softly-focussed autumn colours) for the lost father. On the other hand, Lou Asner's insistently external performance (the monumental male body, the thrusting energy, the refusal to psychologise) as Huey Long in the position of external mediator is out of place and time; he has to be expelled, taking with him the excesses of a self-serving and manipulative politician without changing the structure or its familiarisation under the influence of the symbolic mediator, Roosevelt again. Where the displace-

ment into sexuality could naturalize Cagney's toughness it would here have discredited the familial model so the two domains are held apart.

Only an internal performance in the position of internal mediator can begin to open a serious crack in this structure; Pacino in Dog Day Afternoon is one example and the later stages of Ben Gazzara's performance in A Question of Honor another, on a more muted (less overtly 'Method') scale. In both cases the distance between the potentially disruptive desire embodied in the performance and the power held at the institutional level is less amenable to familialisation (to an Oedipal resolution). Such performances are rare in 'crime dramas' featuring the police.



From the opening massacre of a street gang, lurking in shadowy alleys, by the police perched on rooftops with shotguns (in fact the shotguns jutting menacingly out of the darkness overhead,

their muzzles smoking, are for the most part all we see of the police at this point), Assault on Precinct 13¹¹³ sets up its principal narrative strand between two zones of anonymity. The police and the gangs are two impersonal forces and the ordinary citizens (here simply reduced to one man and his young daughter) are balanced precariously at their interface. The LA county police commissioner, a disembodied voice on the radio over a pan across deserted streets and vacant lots, admits, 'It's true that law enforcement is being driven to deplorable extremes'. The father and daughter are trying to find an address, driving around in a maze of streets ('this horrible neighbourhood', he calls it). It is a predominantly flat and featureless part of the city, with no tall buildings; just a sprawl of dingy houses, many of them boarded up, patches of scrawny grass, the occasional struggling tree and heaps of rubbish on the open ground where buildings have been torn down. The few people there are on the streets stay in the protection of their cars. A gang of armed youths, dressed in uniform black, cruises the area. Spotting a police-car, which we see from her point of view, the little girl turns to her

father, 'Why don't we ask them?' He looks uneasily in the rear-view mirror as they pass the police vehicle, the men inside visible only as shadowy figures. The child persists:

'Mrs. Seward says a policeman is always there to answer questions and to help you when you're in trouble'.

'Obviously Mrs, Seward has never taken any big steps outside the sixth grade'.

The child's view of the police, given to us literally in a subjective shot, is retrospectively (in the rear-view mirror as it were) disrupted by the father's uneasiness. 'We're not in any trouble', he tells his daughter and clearly, for him, it is as much a matter of not being immediately threatened by the police as of needing their help.

Shortly afterwards the girl is brutally murdered by the gang, one of whom is killed by the father who then finds himself relentlessly pursued. Virtually catatonic from shock and fear he takes refuge in Precinct 13, an almost abandoned police-station, about to be closed up permanently with only a skeleton staff left for their final night on duty in the premises. As the gang besieges the building the protection

of the father falls eventually to three people: Ethan, a black policeman; Leigh, a police clerk; and Wilson, a convict.

Ethan, Leigh and Wilson: Ethan as in The Searchers¹¹⁴; the restlessly bitter Indian-hating hero--'our racial prejudice and our guilt for it are placed on his shoulders'¹¹⁵--returns here as a black lawman told by the faceless voice on the radio, 'There are no heroes anymore... just men who follow orders' (perhaps he is Martin grown to Ethan's stature; 'The Searchers may also be read as a manual for non-whites adopted by white society'¹¹⁶); Leigh as in Only Angels Have Wings¹¹⁷ (there spelled 'Lee'), drawn into the hermetic group at the Dutchman's saloon in the Andes where all that counts is to be 'good enough'; Wilson as in Shane¹¹⁸ where he is the malevolent, black-clad gunman but here, as a condemned murderer is offered a chance to redeem himself by joining Ethan and Leigh and putting his frontier skills to use in protecting the father against the faceless menace thrown up by the modern city.

Leigh's first appearance is marked by Ethan's admiring look and a medium shot from just a little off his eye-line. When Wilson and Leigh first meet we see an admiring Wilson from

Leigh's point of view and then Leigh from the same angle as before, slightly off the man's eye-line, in medium shot. The camera both emphasises the active male look (actively organising the given space) and sets itself just enough apart to create a space within which Leigh can temporarily join the two men and escape the passivity to which their look would initially assign her. In short, Leigh is first established between the two men as the isolated object of their look, which is how they both pointedly respond to her, following her with their eyes. By the end, however, this exchange of looks (Leigh returns the look but it is at the beginning always a return, a response) implying difference, and for the men, competitiveness, is controlled by the look of the father in whose defence the three suppress their difference. Before he is carried out on a stretcher he looks back at the three standing side by side. But when he has gone Leigh and Wilson look at each other silently, repressed desire threatening to return: the father's unifying look gone, the exchange of looks in the group returns as potentially de-stabilizing because of the woman's difference. Leigh walks out alone so that Ethan and Wilson, their male

companionship preserved by her acceptance of separation, can walk out together.

The film reaches this conclusion through a welter of sustained violence. Everyone around them dies as the besiegers of the precinct close in inexorably, but increasingly these three are marked as special. It is as if, with the power and 'phone lines cut off, the shell of the building, an isolated enclave in the middle of a city apparently deaf and blind to the event, becomes a place out of time ('I was born out of time', says Wilson). The distinctiveness constructed for Ethan, Leigh and Wilson is based firstly on their individualism (= strong-willed independence) and then on a sequence of almost ritual exchanges which binds them together on the strength of their individualism; so their interdependence is not a primary condition. The place out of time is re-located; it becomes the sheriff's office in Trail Street, in The Proud Ones, in Rio Bravo and El Dorado. Ethan saves Wilson's life, which is the bond between Thornton and Harrah in El Dorado. During the gang's first incursion into the station, Leigh takes a bullet in the arm implacably and kicks her assailant in the groin; the first step in establishing how

'good' she is (also a reprise of the wounding of Harry in Dirty Harry--the same unflinching hardness). Moments later Ethan tosses Wilson a shotgun with split-second timing to repel a sudden invasion; the action repeats a similar exchange between Chance and Colorado in Rio Bravo. (And like Dude in Rio Bravo, Wilson is always looking for a cigarette.) As they slip increasingly smoothly into this pattern of ritual interaction and mutual admiration ('You were good... I have my moments', etc.) the performances are increasingly drained of emotion, become more external.

The death of Julie (the one internal performance) the only other woman in the station, most clearly marks the beginning of this process. She is understandably frightened, confused, and when Ethan and Leigh begin their initially rather awkward progress towards a position of Hawksian control and externality ('professionalism') she is uncomprehending. When she suggests (panicked as much by the others' lack of emotion as by the gang outside) that they should hand over the now unconscious father (clearly the specific object of the gang's vendetta) in order to protect themselves, Ethan makes a speech about his professional duties and elicits from Leigh a

knowing glance ('Very nice, lieutenant', 'Thank you') as if behind the showy words there is an even simpler prerogative at work. Tearfully, Julie exclaims 'No!' and moments later is killed by the attackers.

So finally there are just the three; they could escape through the sewers but remain to protect the helpless father, reduced to a catatonic shell, the father who would not turn to the police for help but finds it in this other world, this temporary revival of Hawksian values, which is to say this re-emergence of a more secure cinematic tradition of relationships and priorities. The associated values, the priority on being 'good', on the unspoken bond between strong individuals faced with an external threat, on maintaining a 'cool and assured',¹¹⁹ exterior, link the events into an emotional network which has been displaced from the Western genre. So the final carnage (after an explosive climax borrowed from Rio Bravo), the heaped bodies of the gang-members, is as devoid of any attempt to think it in terms of the expenditure of human life as the endless accumulation of dead American Indians across the Western.

When the police finally arrive and the smoke clears over the bodies, the three figures

emerge side by side from the billowing smoky blueness, expressionless and statuesque, for a moment almost ethereal, separated from those around them by their shared ordeal.

This image encapsulates the significance of the external performance. Policing, like flying, racing or animal catching in a Hawksian world, is reduced to being simply a test for the individual: what do the heaped bodies in Assault on Precinct 13 entail for the relationship between the police and the policed community? The goal is the refinement of a hardshell stoicism, which Hawks' characters tend to call 'professionalism'. In the Dutchman's isolated saloon in Only Angels Have Wings, Jeff passes judgment on a dead mailplane flier; 'He just wasn't good enough'. Being 'good' is represented through the external performance, the stolidness and imperviousness of which is made to carry connotations of single-mindedness and an authority based on integrity which is inseparable from a primary independence; if a person is fundamentally dependent on others then (s)he just isn't good enough. Assault on Precinct 13, with its return to the 1968/69 'scenario on armed uprising', demonstrates the way in which this Hawksian arrangement of material functions in relating the idea of the group to the axis of mediation. The

group provides an arena for the test of individualism. Mutual dependence is an epiphenomenon beneath which as the basis of human relations is always a fundamental independence construable as moral uprightness and certainty. Indeed the mediator tends never to let his distance from the group disappear completely. (Ethan and Wilson are mediators; their separate existences are fleshed out at the beginning but Leigh does not exist until they see her.) The archetypal warrant for this distance between the mediator and the group is perhaps the fatherly distance (which is not, however, an exclusion) of Chance (Wayne) from the matey song in the besieged sheriff's office in Rio Bravo.

The more insistently external the performance (typically in response to the greatest threat) the more the body appears untroubled by desire. So it is that when the threat is greatest (when individualism takes on the lineaments of a group) there is a place for woman; she is strategically assimilable if she proves herself 'good enough': drained of desire the look becomes, in such extreme circumstances, the interiorisation of the 'look' of the symbolic mediator, the Father, the source of the authoritarian

demand. But always when the threat recedes there is a falling back on separation and individualism, and the promise of cooperation and reciprocity in the group as a 'normal' state of affairs is spoiled by the woman and her trouble, a problem which is typically constructed in dominant cinema as 'her attempts to drive him to establish authority over her'.¹²⁰

The external performance (much like the bourgeois' respectability expressed through his 'dictatorship over his body' as Sartre suggests¹²¹) advertises (advertising being the contemporary culmination of imitative desire) acceptance of sovereignty at the institutional level and discredits true reciprocity. What is suppressed is not actually the desire below the surface of the performance (in an image all there is is what we see) but the desire of the series, which is to say of the audience. (But suppressed by being channelled away from where it might otherwise go, so that there is still pleasure and the audience does not feel cheated; until, perhaps, the members of the audience go back out on to the streets and then they may think that it is the poverty of the real world that has cheated them, not the screen.) In a period of discredited

authority there is a kind of nostalgia for the absent Father, but not a vague sentimentality, rather a structuring of the analogon, the performances, in such a way as to leave a vacancy for the return of the Father, which is to say of the symbolic mediator which the Oedipal pattern naturalises.

Although extreme instances of performance on the axis of mediation have been of illustrative use here, it needs to be borne in mind that external/internal performance can only be properly understood as a scale providing for a range of possibilities (and, therefore, more ambiguity than has been admitted here) within this kind of structure.

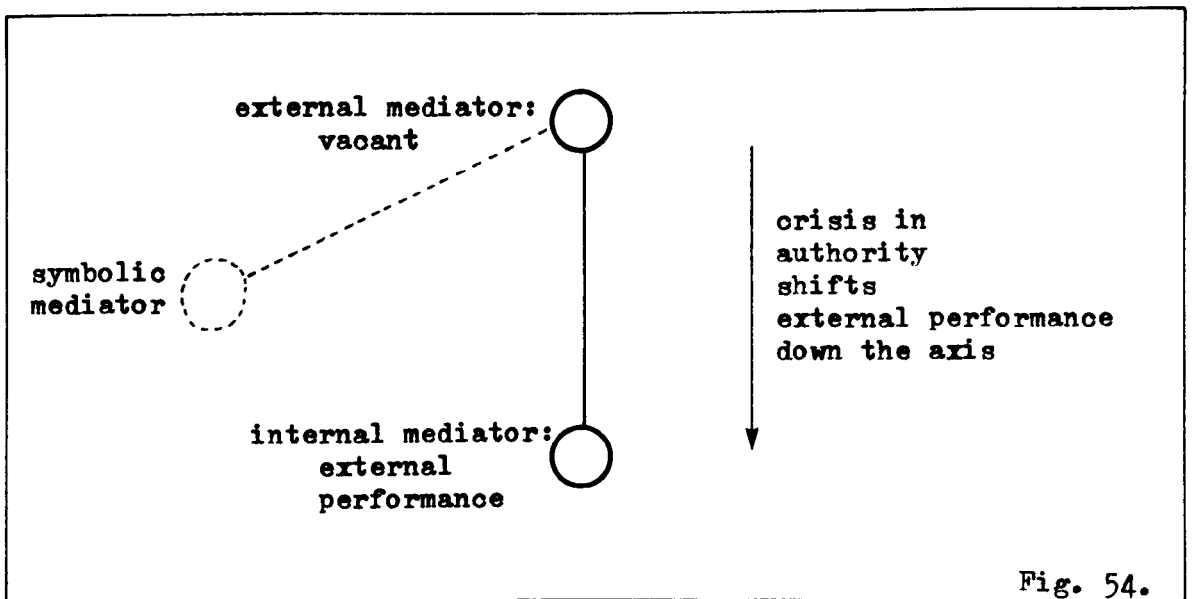

Fig. 54.

Desire is made to respect the law of the symbolic mediator, the Father; it is the law which restructures desire, makes it imitative according to the masculine (institutional) command. What is restructured, time and again, is the desire for deserialisation, the foundation for the emotional investments made by the audience.

CHAPTER 9

POSTSCRIPT : READING

What has been encountered here is a form of comprehension based on an analogon which is the patterning of performances as gestures of the 'outside', representing power and authority within social relations. Performance is the analogon which intervenes with a deployment of substance and form across the three levels which a dialectical criticism may categorise as series, group and institution, but which remain unnamed within the actual operation of the analogon. This comprehension is read through suppositions (about the status of particular characters, the thrust towards discovery and resolution , etc.) which depend on an essentialism: the deployment through performance of certain essentialities within the categories

of 'man' and 'woman'. These essentialities delineate the form of an Oedipal structure (the sexual) which disguises (censors?) the power structure (the political) by a familialisation, marking the authoritarian demand as the 'natural' voice-of-authority of the Father. This displacement operates on the inevitable desire of the series (the audience) for deserialisation in order to question the object of desire, an unrealised completeness, reciprocity, cooperation, complementarity. And the displacement tends to involve, therefore, a masculinisation of the spectator by Oedipalising the object of desire, making it into the problem, 'woman', negativity (based though on the pre-Oedipal completeness of the woman which makes her a natural centre within the object of desire). The 'flight of the dreamer' along the lines of this Oedipal structure is, therefore, not some essential feature of the American imagination, but a disguise for the actual flight (of the serial individual) in search of a quasi-unity within the structure of imitative desire on which the culture industry, and the cinematic within it, depends.

This investigation has been worked through within a broader conception of reading (and the kinds of knowledge which reading may produce) which includes also the practice of investigation itself. To complete the presentation of this conception, two distinctions need to be clarified, which have gradually emerged (but gone unnamed) in the course of the foregoing work.

The first distinction is between the reading of a film by an audience caught up unreflectingly in the imaginary, like the worker and the semi-automatic machine, and the stronger reading (aware of itself as a reading) produced more critically. Harold Bloom suggests that perhaps 'we need two different words for what we now call "reading"'.¹ * His two terms, relaxed and alert reading, encapsulate rather well the implications of the distinction made here. It is in a state of 'relaxation' that the series is taken up (the 'abandonment') into the imaginary, derealising the screen itself. But the question of supposition suggests a second distinction, within alert reading. The primary major supposition of relaxed reading is that there is a truth to be unveiled, a secret

* notes and references begin on p.749

to be reached (hence mysteries and investigations, by detectives, reporters, doctors; by the camera itself). This supposition powers the investigation mediated by a character (or actant). But within alert reading there is often an investigative impulse (perhaps even tutored by fictional investigators) which shares this major supposition, this faith in an essential truth which has to be brought up from beneath the surface.

A distinction is necessary between alert reading which subscribes to this supposition and alert reading which refuses it. Culler² expands on just such a distinction using the terms canny and uncanny (derived in particular from J. Hillis Miller's version of the distinction³). Within the matter at hand, it may be seen that canny-alert reading contents itself with finding the subterraneous 'truth' below the surface revisions. Just as the relaxed reading takes place within a series (the audience) formed around its major suppositions, so canny-alert reading tends to take place within its own series, hence 'structuralism' or 'Althusserianism', for example. The practico-inert (the screen, the name of the intellectual) lays down its boundaries, its limits, its codified patterns for shared

expectations. Uncanny-alert reading looks for the displacements which produce this 'truth', not displacements from a more subterranean level but displacements into the supposed subterrain from what is actually there; in this instance from what appears on screen (organised by the performance-as-analagon) and the audience which watches it in the space 'outside' (the analagon constituting the contact). 'Outside' is a space of both other discursive practices and non-discursive practices.

Sartre questions, in relation to non-discursive practices (social relations, institutions), the juridical model of sovereignty. He does this by investigating the constant interplay of series and groups, the constraints on serialities, the practices of domination, the violence; in short, the conditions of emergence of the State and its apparatuses--conditions which make sovereignty a matter of shifting relations of power: 'an apparatus which constitutes itself inside groups which are institutionalising themselves'.⁴ This apparatus or structural bond forged against the threat of dispersal is revived in the State as de jure power: the first de facto bond revived 'in a

bastardised form'⁵ which concentrates in one place, the sovereign group, control of the forces deployed against seriality in order to hold it at an exploitable level. This centre is not the origin of power which issues irreversibly from it according to the juridical model of sovereignty but rather the effect of the mechanics of organised power at various levels in the struggle against seriality. It is in discursive practices that this direction (from the front line against seriality to the centre) is reversed, the subject emerging in relation to the centre, 'in respect, fear, unconditional fidelity, and sometimes in worship'.⁶

Some small progress has been made here in investigating the comprehensibility constructed within the discursive practices of an area of popular film (a short chronological sample), investigated in relation to Sartre's work on the non-discursive level, the 'substructural conditioning'⁷ on which these practices are articulated, primarily through the audience and the conditions of its emergence. The constant edge of this investigation has been the problem of ideology, and the word 'ideology' has gradually shifted from marking an erroneous area

which can be broken from as thought drives towards a truth unveiled, to indicating rather a constant regressive slippage within the continuous attempt to break with the inadequate expressions, understandings and forms of relations within which we all exist.

Sartre's analysis of the shifting ensembles of groups and series has opened up (from below so to speak) a terrain of ideological struggle, within which we have focussed on the question of sovereignty and its familialisation within the structure of imitative desire. Rather than subscribing to a general theory of ideology as a place of the 'false' which can be left behind, dispelled, this has been a concrete analysis of particular processes, particular slippages (in this case centred on a specific displacement) on the ideological terrain.

Uncanny-alert reading recognises that interpretation is not immune itself to such a slippage. There is something of this emphasis in Derrida's well-known assertion: 'we can pronounce not a single destructive proposition which has not already had to slip into the form, the logic, and the implicit postulations of precisely what it seeks to contest'.⁸ It is in

such a manner that Generalities I are persistently sliding under the means of production of knowledge and the more rigorously generalized material that is produced, making 'ideology' persistently return within this overall textual mode of production with its imbricated systems. In fact, of course, the ideological is fundamentally this mechanism of return itself by which less rigorously generalized material (like 'common sense') maintains itself in areas of struggle within the process of theorizing by which concepts and explanations are refined. So instead of the final arrogantly demystifying drive of canny-alert reading towards totally systematic knowledge, truth severed from ideology, there is the folding back (the reversal which introduces the 'un-' to the canny) of alert reading in the realisation of the final impossibility of such a severance.

Sartre's progressive-regressive method facilitates a recognition of the interdependence of these two movements of alert reading, between the conditions, the social ground, and Intentionality as directedness (not the 'intentions' of an author but forms of structural Intentionality which we will finally grasp as projective forces of instru-

mental reason and desire, defining the horizons of interpretation as phases in the articulation of their 'dialogue'). Far from opposing each other, it may be found that each movement is necessary to locate the other's re-beginning, time and again, to produce the effects of an ascending spiral. While canny-alert reading deconstructs the sets of essentialities (deposited, re-activated, supposed), the 'self-evident' strategies of inclusion and exclusion, which are, as we have seen, the comprehensible narrative effects within a relaxed reading, uncanny-alert reading in turn (precisely) deconstructs the sets of essentialities which are the intelligible knowledge effects within a canny-alert reading. In the present context the latter would claim to approach a totally systematic knowledge of film in general or of specific films. (By, for example, elaborating a theoretical version of the Oedipal configuration which has been detected 'below' the narrative effects of the texts considered here.)

The bending back on itself of alert reading plunges one of its moments (the regressive) once again into the realm of comprehension, taking on the communicative object (here the film) on its own

'given' or 'found' terms--for instance, in terms of a textual 'desire' seeking to overflow Girard's structure of imitation and to solicit the audience as coproductive of this 'desire'--before sweeping it up into an intelligibility in terms of the situation or context.

It was by subjecting Althusser's Generalities to a Barthesian re-reading (to draw out the textual nature of this mode of production) that the possibility of such distinctions emerged here, so it is entirely fitting that Barthes should himself provide what is one of the most flagrant evidences of the need to think in such terms. The Barthes who proclaims the death of the author can only continue to write within or through the shell of the author and, to a great extent, for the serial readership which constitutes itself in relation to the name of the author. Roland Barthes by Roland Barthes⁹ exemplifies the deformations caused by this tension; as Culler puts it, 'we can certainly infer from what has happened since the publication of Mythologies that demystification does not eliminate myth but, paradoxically, gives it a greater freedom'.¹⁰ It is some such freedom that Harold Bloom has taken upon himself as an

active paradox at the centre of the deconstructive enterprise, exploring it further than even Barthes was willing to do at the centre of structuralism. That it remains possible to talk of centres within practices which insist on de-centering everything is to pinpoint the paradox. The GI, such as the old notion of the author, is not simply dispelled when it seems to disappear into the production of a GIII, such as the theoretical death of the author. Rather an area in which to work is opened up. If GII, or ratio, or the theoretical means of production of canny-alert reading closes in in the belief that GI has been dispelled it is, in fact, being decoyed. Instead of the Althusserian GIII as it emerged from his structuralist deviation, the realm of the totally demystified, there is the aporia before which occurs the fold of comprehension as the return of the uncanny, of a scientia intuitiva which is not the self-performance of a God called Theory, against the illusion of theoretical certainty, closure, predictive infallibility, into the terrain of ideological struggle with its complicities and ruses.

Comprehensibility is the non-knowledge which, on this terrain, discursive practices such as cinema produce. It offers sites, therefore, which may be won or lost by a discursive practice which applies itself critically to cinema. The reading of performance as analogon tentatively proposed here engages with an area in which the actor's body as the being-of-the-signifier-in-the-system may be won by the ideological apparatus as a representation of being-in-the-world precisely because alert reading is decoyed into 'discovering' the Oedipal or some other displacement as a deep structure, rather than confronting what is actually there on the surface, which is to say both what appears on the screen and the audience as a series to which it appears, the two bound together by the audience's relaxed reading. In other words, there is the installation in the imaginary of a comprehension of social relations and praxis and if critical practice abandons the mise-en-scene in which both actor and audience find their places, in order to concentrate exclusively on the intelligibility of the coercive and censorial structures of social machines, there is the very real risk that the figuration within that mise-en-scene of responses

to the coercive and censorial will go unrecognised. There will be a sense in which imaginatio, the inadequate, will have always already won the day by the slippage of the audience from real relations into experiencing itself through its members as an indirect gathering, and of the represented relations into the kinds of ideological categories which have been considered in this study. There will be, moreover, the possibility that the non-knowledge produced within the cinematic (an intrinsic comprehension) will be consigned prima facie to the 'falsity' of ideology, whereas, for example, such aspects as the internal performance in the position of internal mediator begin to construct a comprehensibility with an inbuilt self-interrogation, the beginnings of a splitting of the textual space (the mise-en-scene which includes the audience) between the censorial imitative structure and an anticipation of the scandalisation of such constraints.

When, in Report to the Commissioner,¹¹ a routine 'crime drama', a black gunman and a white detective (who has just killed the naked woman, unaware that she was a policewoman, that there has been a 'frame') are trapped together in a lift,

Michael Moriarty's performance as the policeman pitches into an unexpected imbroglio of 'internal' aspects, a gap, a space in the usually tightly packed narrative complex (including the audience's suppositions) is opened up between the body and the institutionalised role, which, within the system of the film (elsewhere conventional, fulfilling routine suppositions) is just the kind of distance Althusser admired in a performance of El Nost Milan (though differently installed). It imposes a radical significance (which leads to the policeman killing himself to join John Wintergreen, Phil Gaines, Joe DeFalco) beyond the actual words used by the black gunman to taunt him:

You probably didn't want to be a cop any more than I wanted to be what I am. You notice something? Something about all of this? You noticed a 'them and us'? It's them and us, man. Look at you, sitting in a puddle of piss and sweat. A while longer, it'll be shit too. Thirsty? Hungry? You're going to die any minute.



It is necessary, if certain confusions are to be avoided, that the distinction between internal and external performance should be carefully established. The first stage of the distinction depends on whether or not the body is given as a firm boundary between two domains: the visible, public space of the film's mise-en-scene and the invisible, private space of a personality, a character which takes priority over and exerts its will on the mise-en-scene space. External performance marks one end of an analytic continuum, where the body rigidly maintains such a distinction. By shielding its 'interior' the external performance allows it a privileged untouchability, a fixity which forecloses any possibility of development or change. We do not expect 'Dirty' Harry, Ironside or Kojak, for instance (and before them Henry Fonda's Lincoln) to be mutable 'subjects'; their performances, and so many others like them, advertise an unchanging 'inner' form. We say 'form' here rather than 'content' because the invisible, anterior domain does not exist: it is the vanishing point where certain ways of handling the ideas of personality and character converge. We will suggest, in the

next and final chapter, that a certain grouping of such ways, such formal operations, produces a distinctive relationship of the supposed 'inner' and 'outer' domains; a relationship based on a means-end rationality which projects a self-reliant and dominating centre through an inert and dominated surface. (A procedure of power which is most apparent today as the omnipresent technological project.) This procedure finds itself mirrored in the kind of operation of author-construction which allows the film or oeuvre to constitute the 'outer' form, the body, of an invisible, anterior, controlling presence.

If, however, we consider the visible surface in terms of the practico-inert, the milieu of materiality and directedness, the separation of 'inner' and 'outer' becomes immediately untenable. The acting and the acted-on are inextricably parts of the one texture. Thus the internal performance tends to dissolve the border line of the body, to break and enter in two directions and so to deny the independent presence and virginal wholeness of an 'interior'. Interiority becomes an aspect of the presence in its effects of the 'outer' form rather than an invisible place defined by the

absence there of the 'outer' form (and, therefore, by another 'presence'). Similarly, the 'author' becomes inseparable from the text and 'dies' as an independent factor (which is not to say, obviously, that the person no longer exists).

This has nothing to do with whether or not we, as spectators, believe in a character, a personality in the text. Within dominant cinema both ends of the analytic continuum, both the internal and the external performance, depend on our belief. Indeed the internal performance may offer more 'depth', more 'roundness', more detail than the external and so seems often to be even more concerned with matters of character and personality. But its significance rests in its celebration of mutability, of the dissemination of interiority throughout the text as, in general, praxis is disseminated throughout the inert. Durand takes the line 'Walt you contain enough, why don't you let it out then?' (Song of Myself, sec.25) to imply the kind of refusal already to 'let it out' which, in our terms, the internal performance does not make:

But what is being performed here? Nothing less than the invention of an inner self, of the self as a hoard of words, as a receptacle of unspoken words, an intimate and secret self: the invention of secrecy itself. The injunction to utter what the subject is supposed to know, to hold within himself, by making it possible not to say it, does in fact create the possibility for a secret.¹²

Against this, internal performance has a certain positive value. It does not challenge dominant cinema's preoccupation with a secretive individualism but it subverts the most repressive form of that preoccupation if it is allowed to find the weak point in the structure of imitative desire.

As a critical perspective, this is only possible if our idea of ideology has an openness which allows for contestation from within as opposed to Althusserianism's tendency to seek instead an antiseptically pure alternative. Sartre's conceptual apparatus is so open in this respect that the term 'ideology' itself can barely contain the complex slippages within institutions, groups and series, of the images, meanings and relations within which (non)knowledge has to produce itself.

The framework chosen here, as a spatial code in which organised narration and theorising translate into a mode of production, is that of

the staggered systems and it is this 'transcoding' that allows ideology to remain in place, in a certain sense, even as theoretical progress is made. And it is the fact that ideology remains in place which makes the recognition of contestation from within so important; making the imaginary an area of potentially perpetual contestation rather than of illusion and falsity which can simply be broken from or in some way disinfected. We have identified certain features on the plane of representations which superimposes itself on the imaginary; features which constitute the contact between the spectator and the film but which, at the same time, hold the imaginary in place and seek to control the elements of internal contestation which focus the socially constituted desire invested in the imaginary. The desire for deserialisation is drawn into the structure of imitative desire but, importantly, the potentially subversive desire has always to be there in the first place before it can be controlled or managed. It is there constantly in the cinematic, as will be argued further in the next chapter, before the cinematic disappears into 'television' or 'cinema' and the textual levels into the masquerading fabula.

By superimposing on the spatial code of staggered systems an ascending helix developed from Sartre's progressive-regressive method we have sought to represent, in a way compatible with the critical approach taken to organised narration and theory, a mode of production which embraces a dialectical phenomenology. (Roslyn Wallach Bologh's study of Marx's method demonstrates 'how a positivist mode of theorizing corresponds to a capitalist mode of production and how dialectical phenomenology as a mode of theorizing corresponds to a socialist mode of production'.¹³) In this context the present study has added a narrative model (deposits, re-activations, supposition-generation, etc.) to the relationship between mode of production in general and modes of theorizing and, indeed, has focussed primarily on narrative matters. What is unavoidable, as we have found, is that potentially subversive narrative 'voices' and a dialectical phenomenology must begin on the grounds of the rigidly policed narrative and of the 'imperialist fiction'¹⁴ of pure theory respectively, with both of the latter turning on the promise of an essential 'truth' and organised, therefore, by a structure of positions which holds in place the 'truth' and the seeker after 'truth'.

The latter is split, as an actantial position so to speak, between the serial subject and the mediator who may be the hero or the 'universal' intellectual.¹⁵

For organised narration this structure of positions can be considered as a discourse of disclosure, and for theory as a discourse of knowledge: although they would find their 'truths' in different places, structurally (that is in terms of their epistemological process) these discourses mirror each other. If a major outcome of this Part has been the specification of a discourse of the Father which gives primacy to the Oedipal positions in order to fill the troubling absence, the empty tomb in the imaginary, an absence which we have grasped in terms of a socially constituted desire, then it is necessary to ask if this discourse may not also have its mirror-opposite.

This would be a discourse which presupposes the discourse of the Father as its other (just as the discourses of disclosure and knowledge presuppose each other) in order then to negate it. The discourse of disclosure (the positions and effects of the narrative mode of

production) gives primacy to the relaxed reading of the serial subject and produces as its chief effect the lure of a 'secret' hidden in the fabula. The discourse of knowledge (the positions and effects of the theoretical mode of production) gives primacy to its own status as discourse, its internal coherence, and produces an objective 'truth' which may ultimately be severed from ideology (if the fourth discourse does not effect the fold or turn) without any consideration of the subject as a real spectator caught in seriality by the screen or of the socially constituted desire invested in the texts which the discourse of knowledge tends to dismiss as coincident with ideology. (This is the blindness of Althusser's most extreme structuralist position but the insight of his Spinozist ideas of immanent cause and decentred structure simultaneously re-opens the question of ideology in ways which have been considered here.) The discourse of the Father gives primacy to the symbolic mediator as the organising signifier of an Oedipal pattern but actually produces, in effect, an 'institutional level' within the text to counterbalance the serial level of the audience and to control the displace-

ment of the audience's desire away from its object. The fourth discourse would, to complete the pattern, give primacy to the object of desire and, in a certain sense, would produce situated subjects in coexistence as its 'knowledge'. Over and against the 'institutional level' produced by the discourse of the Father, the fourth discourse would perhaps produce what O'Neill terms 'the phenomenological institution of reflexivity':

The institution of reflexivity is founded upon a series of exchanges between subjectivity and situation in which the polarities of means and ends or question and answer are continuously established and renewed, no less than the institution of ideas, truth, and culture. Reflexivity, therefore, is not an a priori, but a task which we take up... . What emerges...is that the universality and truth aimed at by theoretical consciousness is not an intrinsic property of the idea. It is an acquisition continuously established and re-established in a community and tradition of knowledge called for and responded to by individuals in specific historical situations. ... Such a collectivity or institution is never wholly reified; it is made and unmade... . We cannot accept the paradigmatic value of the psycho-analytic conversation, at least insofar as the passive objectivity of the analyst is false to the dialogic search in which no member of the language community is absolutely privileged, and is therefore necessarily historical rather than clinical.¹⁶

This kind of reflexivity is not a return to the subject in the sense of drawing in personal motives, experiences, assumptions, observations and choices as together a biographical 'infrastructure' of knowledge. O'Neill's emphasis on the historical collective dynamics of a community, on the establishment and re-establishment of rigorously generalised material as a continuous (re)making of truth, a kind of cumulative realism, insists on locating social relations and practices within the knowing of the object; it is, therefore, an emphasis which returns to the real grounds of subjectivity as a form of life. Sartre's categories, as deployed in this study, are a theoretical framework for getting a purchase on grounds in this sense. They work within the knowing of the cinematic object. They provide a foundation and interact in order to 'ascend' to the concrete which is the ceiling for such work in the sense that it is the appearance of the social as 'ungrounded', as the discrete and multifarious thinginess of everyday life. The mode of theorising which carries them, however, actually distances itself from the concrete as it grounds itself with increasing thoroughness by the reflexive movement, the turn through which

the discourse of knowledge folds into what we can call, not the discourse of the analyst, but the discourse of grounds (the positions and effects of a dialectical phenomenology).

The discourse of knowledge as it has appeared in Althusserian guise within cultural studies has been couched here in general terms. We have not identified specific readings of films within this discourse against which to set our own. There are two reasons for this. The first is that what is proposed is a certain bending back of the Althusserian monologue to connect it with a broader conversation. In other words, the Althusserian trend in cultural studies carries within itself a crucial set of positions and effects (its problematic, heavily influenced by Screen, by psychoanalysis and, in different strands, either by what Godard and Oshima were doing in the early seventies or by youth sub-cultures) which has enabled a great deal of valuable work to be done and so the present study has not been concerned to contest specific instances of the trend but rather to question the assumption that its prevailing direction can simply continue towards some ultimately and absolutely 'scientific' condition. The second

reason is that this prevailing direction has, in fact, been steadily away from close readings of particular films ('reading' instead, for example, deep focus cinematography or point of view as matters of expression and studio production as ideological operation) so there are no readings to set against the kind of interpretations constructed here.

The engagement with Althusser's work has, therefore, been in the area of the epistemology of reading rather than within specific readings. Chase's essentially pre-Althusserian reading of Dirty Harry (although Althusser's influence is clearly anticipated) was found to be useful in presenting the difficulties which have to be confronted by a critical practice that knows itself to be inescapably political, difficulties which an Althusserian reading of Chase's text exposed. The principal difficulty was found to be that of relating different levels of social reality as they impinge on the texts (Chase's writing and Dirty Harry) and this difficulty has led the present study into a consideration of structural causality on Spinoza's model. The next chapter will summarise the various ways in which the term mediation has been rescued here from Althusser's contemptuous dismissal and related to the concept of structural causality.

The overarching scheme within which the concept of mediation has been operative here is that of a general conception of mode of production based on Althusser's application of the term by analogy to practices and levels other than the economic and on a conception of organised narration as similarly articulated and containing similar sets of elements. (Balibar usefully defines a mode as 'a system of forms which represents one state of the variation of the set of elements which necessarily enter into the process considered'.¹⁷) The structure which has emerged from this scheme, a dispersed structure through which the interpretive movement works outwards to social and historical grounds as defining textual horizons, will also be provisionally completed in the next chapter but some general observations can be made here.

By recasting mode of production as a structure it is possible to limit economic determination to the status of an effect of the conjunctural investment of the structure; an investment which represents determination in the first instance. In particular, technological determination as a feature of modern capitalism

will be found to have a textual place as a form of rationality investing the sovereign 'first term' of the narrative semiotic developed throughout this study (ritualism, external mediation and, in the next chapter, instrumental reason--all supporting certain institutional features). The 'first term' is potentially a hinge by which this work could be articulated with more detailed work on the economic and institutional contexts of dominant cinema and television but the present study has limited itself to a text-based approach and, specifically, to a narrative semiotic. The institution has been taken here as a term in the system of collective dynamics developed by Sartre in the Critique and which along with sovereignty, seriality and the absence of a subject-group (unconstrained reciprocity, the absence of which underpins the 'object' of a desire for deserialisation) can be understood to have a textual existence: such terms are, in short, appropriated here as semiotic categories.

The relationship between these categories and actual institutions (studios, TV channels, etc.) and actual series (amenable to audience research) remains an area for further study. The ratio of functions

(with the referential dominant) which produces classic realism may be considered, however, as itself a textual institution and so suggests how the complementary ratio examined here (an orientation towards the contact as analogon) which produces the institution as a semiotic category might be related by further work to actual institutions through this textual institution. But one proviso that the present study would place on such work is that the relationship between classic realism and a sexist specularity (man as look, woman as object) needs to be grasped in a more thoroughly political way than psychoanalysis alone has yet shown itself to be capable of. Some steps and examples towards such a political criticism ('political' in the sense that it recognises its own political status, its own policing function, its own grounds) have been constructed here on the basis of Sartre's categories.

This raises, in general, the problem broached in Chapter 2, section 1, and which has returned persistently throughout Part III: whether the relational element of structure in some sense derives from a privileged, invariant and determining

essence or signifier--a signifier of economic and phallic individualism--which can be centripetally located, or whether (as R or GII) it represents only the means of production as an invariant formal factor within a combination of elements, a structure, which is invested in variable ways determined by the concrete conjuncture. In a sense, for a grounded mode of theorising it has to be both: just as economic determination in the first instance, determining the 'first term' in a system of semiotic constraints, arises in a social formation based on the homology of the economic mode of production and mode of production as a general structural concept so phallocentrism arises on the basis of the homology of the structure of sexist specularity and the actantial structure as a general concept, but in both cases it is necessary to think of structure (mode of production and actantial structure) in a sufficiently open way to permit the codified policing, which is determination by the economic and the phallic, to be located in a structure capable of anticipating alternatives. The 'homology' itself is historically specific and not invariable. To be more precise, ritualism

and external mediation, as these terms have been developed here, are textual disguises for a powerful rationality bound to capitalist economic practice and phallogentrism. Interpretation has both to recognise the power of this sovereign rationality and to think its way out of the terms and relationships which it provides. The idea is being developed here that the texts of popular culture tend already to prefigure such a 'way out', even if it is then closed and its own potentially subversive power contained. This idea becomes the main concern of the final Part.

With the development of the spatial root metaphor in order to have a set of terms adequate to the task of 'translating' the several objects of this study, what also begins to come into sharper focus is the nature of the so-called epistemology of reading within which such a set of terms can usefully operate. Certain definite features of this can be recapitulated. The most general proposition is that sign-systems and unmediated reality do not neatly correspond; this much is unsurprising given the strong tradition which the notion has from the idealists to the post-structuralists. The emphasis on making rather than

original finding (simple realism) is central to this thesis but is, in itself, little more than the 'common sense' of theory as a contemporary genre. The most significant aspect of it here, though, is a little less commonplace and derives from Richard Rorty's suggestion that where idealism sought to substitute philosophy as a science, a well-defined discipline, for natural science, contemporary textualism treats philosophy and science as essentially literary genres.

Textualism is 'a specifically post-philosophical form'.¹⁸ Rorty also introduces, however, the possibility of a 'post-philosophical philosophy' and it is in relation to such a possibility that the present study's concern with an epistemology of reading is, in a certain sense, a post-epistemological epistemology.

Clearly the prefix post is being used here, as elsewhere in theory, in a very particular way. Once it has established itself it tends to attach to a variety of terms: Marxism and semiotics, for example, show signs of developing their own 'post' phases under the influence of textualism.¹⁹ This is not a matter of 'development beyond...' but of transformation from within by turning methods and concepts against each other rather than allowing

them to accumulate into some spurious wholeness. The term to which 'post' prefixes itself is, in this sense, anything but an origin. Thus, as was suggested in Part II, structuralism does not have an original wholeness against which to set post-structuralism as a subsequent development; rather textualism has always been present in structuralism, as we have chosen to emphasise by concentrating on the 'two structuralisms' rather than opting for the structuralist/post-structuralist terminology with its inbuilt risk of underestimating the differences already at work within the first wave of theory to arise from the Saussurean model. The areas of difference of particular concern here have been the issues of the derivation and scope of knowledge and the reliability of claims to knowledge. This has not strictly involved an engagement with the history of epistemology for a number of reasons. The first derives from textualism's post-philosophical status.

The elements of an epistemology of reading evident here make no claims, of course, to having discovered a true theory of knowledge. Rather they implicitly question the very possibility of such a claim and consequently 'epistemology' approaches,

for the purposes of this kind of work, the status of the other branches of the literary genres of 'philosophy' and 'science' which elsewhere might claim to be doing more than constructing texts: approaches but does not quite join. What we have called an epistemology of reading is not finally compatible with the most ingenious textualism: the latter would, in fact, banish the word 'epistemology'. It is here that Rorty's notion of a 'post-philosophical philosophy' would seem to allow us to retain a kind of epistemological consideration within the carefully circumscribed limits of this study and to have it mean something firmer than it possibly could within the extreme form of textualism which claims that there are only texts. Rorty, a little unexpectedly at first, calls advocates of the latter 'weak textualists':

This sort of claim gets made because such critics have not grasped that, from a full-fledged pragmatist point of view, there is no interesting difference between tables and texts, between protons and poems. To a pragmatist, these are all just permanent possibilities for use, and thus for redescription, reinterpretation, manipulation.²⁰

This is an emphasis, again, on (re)beginnings rather than origins.

That we shall not see an original, unmediated reality is not the same as seeing only texts. The nontext exists. Redescription, reinterpretation can cross the boundary between text and nontext once it abandons the idea that if the text cannot simply correspond to something outside itself then there is nothing out there worth considering. The strong textualist realises that it is the border line between text and nontext that causes the difficulties and that an interpretive movement which threatens the stability of this border is not necessarily extending the idea of the text to embrace everything. The latter course leads to the apparent fact that 'epistemology still looks classy to weak textualists'.²¹ But one needs to balance an avoidance of the 'wierdly solemn pretentiousness' which Rorty sees in critical attempts to be 'epistemological' against Eagleton's reminder (and this only echoes the commitment of the critical theorists or of Sartre) that after the Holocaust and Hiroshima it is vital that critical practice should contest within itself the 'unpolitical' political language and assumptions which hold to the

idea that 'at the centre of the world is the contemplative individual self, bowed over its book'.²² To take over Rorty's distinction, the weak textualist's self-deception is in thinking that something is achieved if the contemplative self is made to disappear into the book or into the screen (and ultimately into some bigger system) as an effect of the positions inscribed there. For a strong textualist--the 'full-fledged pragmatist'-- there is no important difference between reader and text but this does not mean letting the real reader and the grounds of reading disappear into the text (any more than an older 'humanistic' tradition with a perspective opposite to textualism's meant letting the text disappear entirely into the self).

The crucial point is that epistemology as inevitable constraint (like the lines of organisation which bind series to institution) stubbornly refuses to go away. Knowledge is still constructed even if it is not knowledge of experience, truth, reality, but knowledge of the text. And just as 'unpolitical' criticism is itself a political stance, so 'un-epistemological'

criticism is itself epistemological and may even secretly pretend to itself that it is a better way of doing epistemology than 'philosophy's' way. The weak textualist, inheritor of Lévi-Strauss' structural centripetalism, aims to develop the method, the scientific approach which will produce a better kind of knowledge--a knowledge of textual workings rather than a knowledge of reality, a textual 'truth' rather than 'truth' in the world. By enlarging the compass of the text this kind of (produced rather than found) 'truth'--the Althusserian knowledge effect at its most imperious--can levitate to the point where it solemnly surprises itself with the extent of its own conventionalist epistemological claims.²³

If, moreover, the demise of a certain foundational kind of epistemology is accepted, it remains the case that the desire for firm ground, for constraint, implied in the notion of a foundation, will not simply go away. The will of discursive thought to keep in touch with the real world, as a kind of ceiling held in place by epistemological foundations, cannot itself be

done away with by a consciously ironic perspective on 'truth'. A feature of this study indeed is its insistence on finding within the peculiar form of reasoning called narrative, a will to truth which produces a kind of knowledge which critical practice must not simply throw out in favour of its own game-playing.

The epistemology of reading proposed here is a post-epistemological epistemology in the sense that it locates itself, not within epistemologically centred philosophy but within the cultural space left by such philosophy and finds there the continuing manifestations of a desire for constraint (like imitative desire, containing the desire for liberation). These manifestations appear, in the present context, as the discourse of disclosure (the fictional discourse) and the discourse of knowledge (the scientific discourse); each holding the other in place by the very fact of their opposition. Applied to films as texts this becomes a redescription of the dialogic property in one guise. In another, this property appears as

the discourse of the Father set against the discourse of grounds which is a preoccupation of this thesis, necessary as it is to complete the circuit and so enable the 'helical' movement by which critical practice can cope with the relationship between text and social reality and aspire to a kind of gradually accumulating internal realism.

The fourth discourse effects a Spinozistic turn and is a way of constantly re-beginning. It can do this by rejecting the variant of strong textualism which takes over where the discourse of knowledge might otherwise leave off; takes over and goes beyond epistemology in search of what Rorty views with suspicion as 'some mighty, inhuman force to which one can yield up one's identity'. There is at least the possibility of another kind of strong textualism, one which preserves a 'sense of our common human lot'.²⁴ As a way of dealing with texts this would not involve a better sort of epistemology but would nevertheless return to the space in which the will to truth still operates in a dialogue between fiction and science (rather than in the overriding claims of a monologue);

a dialogue whose constraining lines of force maintain a narrative knowledge. The invention of a code capable of coping with these lines of constraint has been fundamental to this thesis.

Where such constraining lines of force are basically synchronic there is also a kind of story, a fabula, embedded in the progress of this study. It was in fact contracted from The Wild Bunch in the first instance; a story of self-regard, wounding and aggressive defence. Self-regard is the effect of the hall of mirrors by which author, hero, spectator and critic narcissistically feed off each other before theory enters the scene and cracks the mirrors. In Part I, the invented term 'characterism' is the point where this study anchors itself in that scene, the invention of terms characterising the critic's self-regard. Structuralism wounds such self-regard and calls forth a defensive aggressivity:

The human writes, the human thinks, and always following after and defending against another human, however fantasized that human becomes in the strong imaginings of those who arrive later upon the scene.²⁵

As polemical evidence of a defensive aggressivity this enacts something more complicated than the return to 'humanism' it appears to be: Harold Bloom backs it up with a unique critical edifice, his Map, but does so in the midst of the deconstructionist project which undermines precisely such edifices and such an explicit drive to be an original theorist. There is something important here but it can as yet, perhaps, be only dimly perceived; against language, writing, the Other, in short against the invulnerable system theorized by the other kind of strong textualist, Bloom sets up a subject destined not for tender deconstruction but for destruction, a more familiar fate in these times. Whereas the former has little place for what Rorty simply calls 'our common human lot',²⁶ at least Bloom's subject goes out resistingly. This is not a tenacious clinging to naive 'humanism'; the subject still finds itself inevitably and severely diminished to the point where relations between subjects are all that can be surmised to have properly existed but, sited amid the deconstructionist enterprise, Bloom's criticism concerns itself

with the manner of the subject's going. Bloom is the écrivain whose 'humanism' is largely a matter of words not of the world; he inserts his textual body into a system and maintains there a dialogue with the otherwise tyrannical deferment of the human. The subject must not be allowed to vanish so easily into the inhuman, into the cinerary urn. Leitch offers an image of the still resistant subject redolent of Auschwitz when he suggests of Bloom that 'his post-Freudian "subject" ultimately gazes upon us as embattled rags on a stick, rivaling a Giacometti figure in severity of diminishment'.²⁷ What can be glimpsed here is a lost possibility between the perishable ideology of liberal humanism and the differential network that displaces it; that between the tyrannical system and the emaciated subject, reduced to the ultimate relation of seriality (united only by the cinerary urn), is a space criss-crossed by constraining lines of force where, nevertheless, the possibility of a fused- or subject-group resides. Such a possibility can be read in the difference between Bloom's work and a more remorseless deconstruction, between on the one

hand the wilful maintenance of a stickman-pennant by ignoring the complex forces of discursive and social formations in favour of the psychic battleground where it stands, and on the other the displacement of the semiotic project by the licentiousness of an 'irresponsible anarchism'.²⁸ The only rigorous attempt to think through a collective dynamics in the intervening space has, as yet, been Sartre's. Bloom's criticism is properly inimitable for the reason that it embodies in its own elaborate processes the very dilemma of the subject who 'chooses destruction by fierce struggle with the invulnerable Other rather than deconstruction by the insistent forces of decentering rhetoric'.²⁹ It is in what is missing from this choice that the Sartrean project is recognisable.

The potentially endless conversation between the discourse of knowledge as a theoretical practice aspiring to the status of metalanguage, metanarrative, and the beguiling rhetoric of the text with its discourse of disclosure, its narrative, is something which cannot, in any easy sense, be resolved. In

generalising on the model of Sartre's progressive-regressive method, it becomes possible to conceive of a way of interpreting texts, social relations and practices which does not operate outside this dialogue for the very reason that it has no existence other than the existence of the dialogue. Such an approach may be understood as embracing an element of dialectical phenomenology which, as Bologh argues, treats subjectivity not as originating with the individual, nor as an epiphenomenon of social forces (the poles of the traditional phenomenology/structuralism dichotomy) but as 'an ongoing social (historical) accomplishment'.³⁰ The underlying concern in the appropriation here of a conceptual apparatus drawn from Sartre is that such an ongoing accomplishment, as caught up between seriality and institutionalisation, presupposes the constant possibility also of group fusion; a possibility which Guattari summarises rather more memorably than does Sartre: 'Only a subject-group can manipulate semiotic flows, shatter meanings, open the language to other desires and forge other realities!'³¹ There are striking parallels between, on the one hand,

Guattari's broadly and polemically conceived distinction between the subjugated group and the subject-group and, on the other, Sartre's painstaking elaboration of a distinction between the organised group and the fused group. With the latter rests the possibility of a direct opposition to alterity, to the separation and lack of reciprocity which the audience in front of the screen embodies. But where Guattari and then Deleuze celebrate subject-groups as attainable 'agents of enunciation, pillars of desire',³² Sartre locates the essentially similar fused group in a dynamic where its destiny is to disappear: 'through this ephemeral, superficial formation, everyone glimpses new, deeper, but yet to be created statutes' (among which would be the class as a group). It is as a glimpse of the yet-to-be-created that the desire invested in the fused- or subject-group can be more usefully grasped in the concept of a desire for deserialisation than in the supposedly attainable object posited by Deleuze--'where analysis and desire finally meet on the same side, where it is desire at last which leads the analysis'.³³

Nevertheless, Deleuze's powerful statement that desire is the subjectivity of the economic, its unconscious in a certain sense, remains exemplary:

The dualities objective/subjective, infrastructure/superstructure and production/ideology fade away, giving us access to the strict complementarity of the desiring subject of the institution and the institutional object.³⁴

Anchored to less precipitous ground this could be a statement in defence of a theoretical fold or turn to include a dialectical phenomenology addressing itself against 'a production in which a subject fails to recognise that its object and itself are products of their relationship'.³⁵

PART FOUR

CHAPTER 10

NARRATIVE REASONING AND EMERSONIAN OVERFLOWING

10.1 Mediation

Two kinds of mediation have been elaborated in the preceding Parts and they need now to be distinguished more clearly. Part III has concerned itself with identifying the synchronic mediation which is, so to speak, the memory-picture produced by the police films which have been studied.

Part II, however, established the place of diachronic mediation within a narrative semiotic: the interaction of actants and functions in order to proceed from a disruption to a resolution.

Apart from the synchronic/diachronic distinction these also entail different degrees of interaction with the place of the spectating subject: diachronic

mediation is a narrative procedure and our interpretive efforts have seen it confined to the formal plane of Washington : Behind Closed Doors, but synchronic mediation has been located at right-angles to this plane and has implicated the viewing subject positioned in actual social relations. It is possible to see diachronic mediation as serving to establish, in the course of a narrative, the static memory-picture or 'image'. A film cannot easily present the latter without the work of the former.¹*

The initial disruption on which the narrative works has involved, in the examples studied, a disturbance around the position of external mediator (in the synchronic 'image'). The narrative work has been, therefore, to present and re-stabilize the synchronic axis of mediation, either by satisfactorily filling the position of external mediator or by offering an internal mediator who stabilizes the synchronic axis in such a way as to leave the position of external mediator (temporarily?) vacant. The woman's function has been as the principal diachronic mediator of such a return to stability, although as we have seen this is in part only a coding of a

basic function which can be analysed in more abstract terms. In the light of Part III a final interpretive move can be made in establishing the semiotic constraints at work through Washington : Behind Closed Doors -- Martin is constructed as an internal mediator in anticipation of Monckton vacating the position of external mediator on the synchronic axis, and Martin's external performance stabilizes the axis and the structure of sovereignty which it implies. In diachronic terms it was necessary to separate the women in the analysis presented in Chapter 2 but in synchronic terms they are 'woman' within the static triangular structure.

Narrative 'intelligence' or reasoning, therefore, is a matter of exploring and opening up the spaces which the structure of imitative desire attempts to hold in check; this is its pleasurable tension. The structural gaps which were hypothesised as a 'loss' in Chapter 2 are now degrees of failure to close up these spaces, to resolve the diachronic mediation in synchronic terms. We have found the police film conspicuously able to enforce such closure but the problem of The Wild Bunch in Chapter 1 continues to suggest

that the Western may have become particularly interesting in losing its automatic capacity to do so. The structural 'gain' which we found in Washington : Behind Closed Doors represents the establishment of the internal mediator as a second line of defence to prevent the collapse of the synchronic axis when the external mediator is removed, discredited or found to be 'absent' in some other way. Ironside, Kojak, etc. are cyclical in that they constantly reassert the right of the central character to the institutionalised position of external mediator. That the 'gain' involved in the establishment of an internal mediator seems to be more 'interesting' than the cyclical pattern (as in Baretta for instance) does not necessarily imply that there is any radical challenge to the structure; it depends on how this function is 'performed'. Joe in A Question of Honor shows the function to be incapable of taking the stress of establishing a 'gain' over and against the discredited position of external mediation. A 'loss' would primarily be the case of a disturbance in the function of external mediation which is not managed by either the successful re-occupation of that position or the offer (successful or otherwise)

of an internal mediator; in other words a narrative that cannot get beyond the diachronic mediation, with potentially subversive consequences for 'woman' as the coding of that function. We have not encountered any examples of this in the police film.* But the unsuccessful attempt at recovering stability through the 'gain' of an internal mediator does, to some extent, entail a 'falling back' into a position of 'loss'; hence the series of dead policemen which we have traced as a significant disturbance within the certitude of the sub-genre.

It will be useful if we can clarify the necessary opacity of this summary and, as throughout this study, the simplest way of doing so is diagrammatically. It needs to be remembered, however, that diagrams with their persistent risk of over-simplification and rigidity are not the 'result' of the body of argument but a tool for gaining access to it. This then is the synchronic mediation, with the symbolic mediator holding the axis in place, counterbalancing the object of desire:

* Sudden Impact (1984) exhibits, however, a marked degree of desperation in getting past the coding of this function to some semblance of the stable synchronic 'picture', see pp.725-28

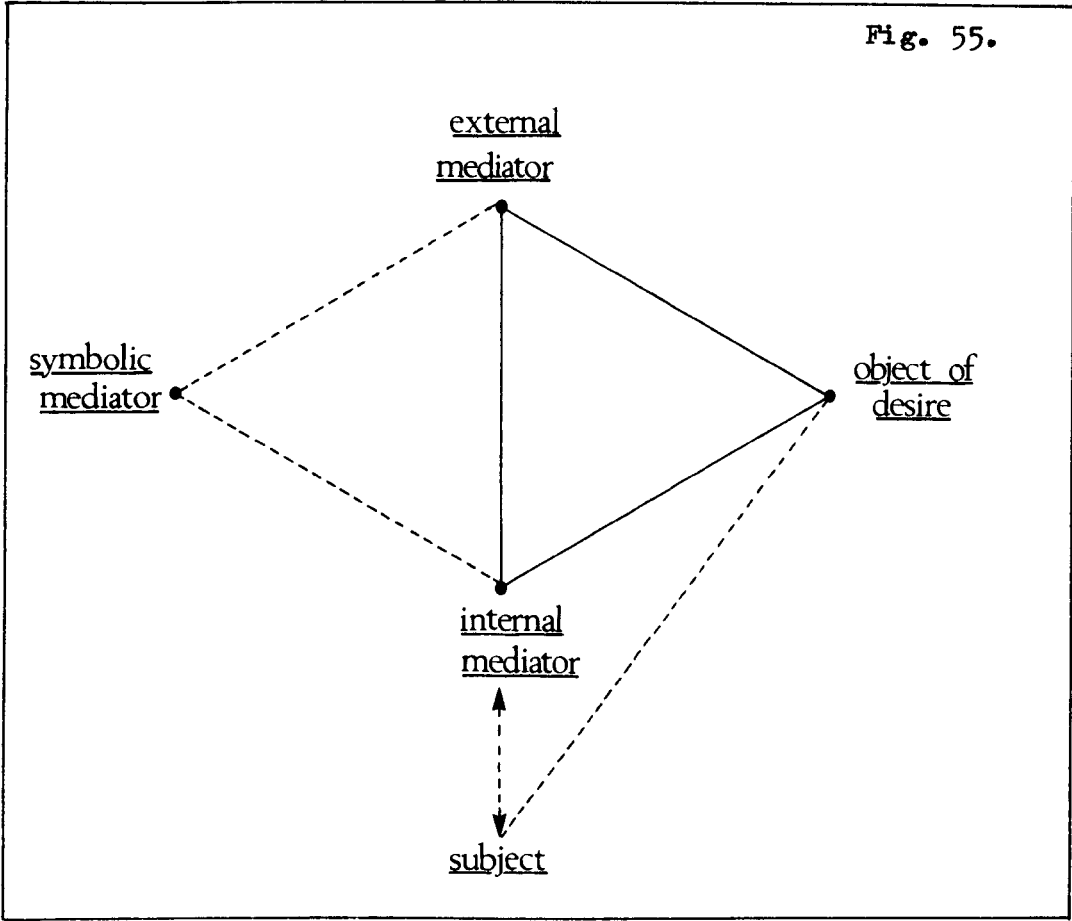

And the diachronic mediation:

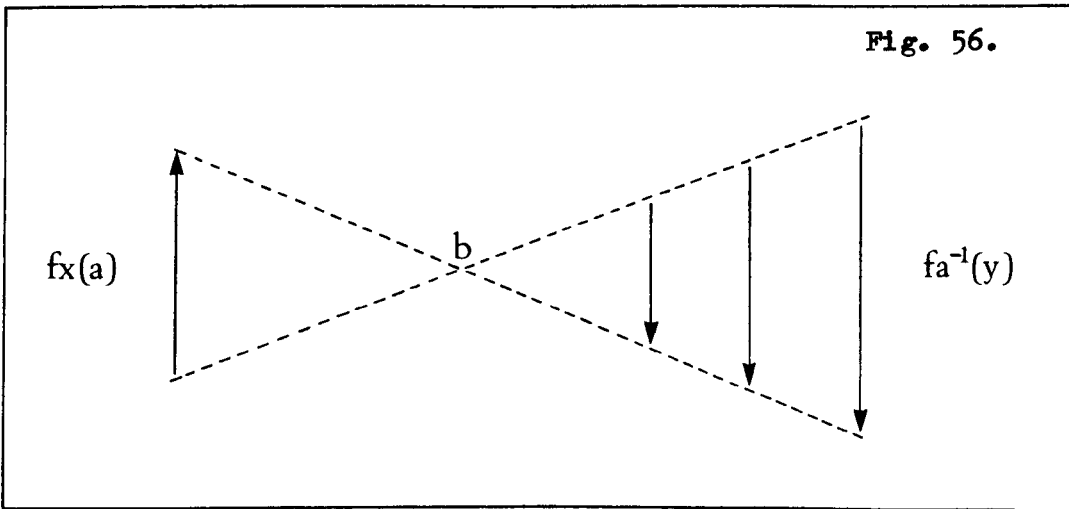

If fx is the disturbance in the function of external mediation then the middle 'inversion' simply rights that disturbance and replaces the external mediator. Thus for Kojak : Wall St. Gunslinger, considered in Chapter 6:

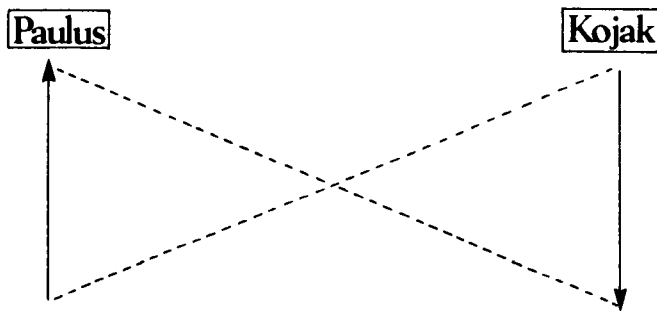

Fig. 57.

The villain's attempt to usurp the apical position is thwarted and Kojak established there authoritatively through his detective abilities and power. The synchronic 'image' appears to shift the woman (around whom the narrative has turned) to the other side of Kojak's axis because, importantly, this is a memory-picture applied retrospectively--this is the way things always were, Kojak has always held the position of authority and power, and so the synchronic 'image'

retrospectively supplants $fx(a)$ and its temporary disturbance. In the episode of Baretta there is a more complex 'inversion':

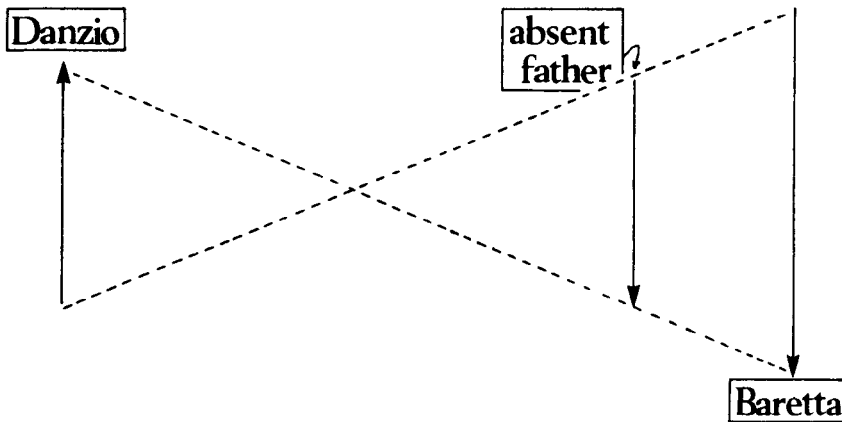

Fig. 58.

Here the cyclical movement finds only a literally absent father but Baretta secures the apical position for his return, adding to the structure his own position as internal mediator. In the synchronic 'image' which collapses the narrative extension of the structure, the positions of external and internal mediation are aligned on one axis.

What then is the relationship between, on the one hand, synchronic and diachronic mediation as substructures and, on the other, the concept of mediation within the structure of the social formation as a whole ('society')? We have begun to grasp in the present study a narrative mode of production in terms of semiotic constraints, ratios of interdependent functions (with the referential dominant), suppositional patterning and a staggered series of narrative sets informed by deposits and anticipations. These sets at the complex level of the aesthetic text may be taken to constitute, as we have seen, the functives of 'expression' and 'content' successively correlated by elaborate coding procedures--the hermeneutic code (or investigative structure) in particular. We have examined certain features of the correlation of such large-scale functives in terms of layering and found critical practice deeply implicated in the attendant spatial metaphor. The consideration of suppositional patterns has made a start in specifying the conscious (and possibly pre-conscious) procedures within what Eco terms communicational acts:

Insofar as the aesthetic labour aims to be detected and scrutinized repeatedly by the addressee, who thereby engages in a complex labour of interpretation, the aesthetic sender must also focus his attention on the addressees' possible reactions, so that the aesthetic text represents a network of diverse communicational acts eliciting highly original responses.²

A secondary question has, therefore, arisen in the course of the study; whether the institutionalisation of critical practice in film and media education may not be in certain respects a colonisation of the pensée sauvage in such acts and what in turn the implications of this might be. The suggestion has consequently been made that suppositional patterns may be only the conscious evaluative manifestation of a more complex emotional arousal and investment with an unconscious network which we have thus far only managed to approach through the notion of the continuous but repulsed force of a desire for deserialisation.

This substructural narrative mode of production may, therefore, be considered to produce social relations (seriality) and unexamined representations of relations and appearances, which reproduce and support the relations fitted to general commodity production, the general mode of

production or structure. But a major part of the present work has been the identification of a disturbance at the point theorized as external mediation on the synchronic dimension of the substructural narrative mode of production. The nature of this disturbance is tied to the question of mediation in general; that is of transcoding* among the various levels of the social formation (where our substructural synchronic and diachronic mediations have been confined to the instance of ideological struggle as it penetrates the texts studied; the Sartrean perspective emphasising the complex conditions of such struggle over and against Althusser's at times more monolithic and univocal concept of ideology).

The concept of such transcoding or conversion of analyses from level to level can be deeply tainted by expressive causality and it is Althusser's work that allows us to be properly alert to this difficulty: we have not suggested that the filmic material under consideration simply 'expresses' other levels, whether the ideological or ultimately the economic. Although Althusser accuses Sartre of using the concept of mediation in this way, we have found the idea of the analogon

* for the basic framework of this concept see p.90 (Vol.1)

to be, in fact, rather more sophisticated. The principal aim of Part III has been to establish the kind of analogon that will allow the texts studied to be informative about an area of social life in which the 'levels' are always already seamlessly interwoven--but this does not imply that there is some essential common denominator hidden away which may then be seen to be 'expressed' on all the levels when they are theoretically reinstated. As the levels are reinstated in general terms in this concluding chapter, the status of mediation as transcoding will become clear. Only in this way can the cultural and ideological instances be grasped as working on (by displacement for example) the problems which arise on other levels of the social formation (but not always with univocal 'results'--hence there is a problem with any notion of monolithic cultural imperialism). This emphasis relies heavily on Jameson's observation: 'The practice of expressive causality, in which similar processes are observed in two distinct regions of social life, is one of the forms mediation can take, but it is surely not the only one.'³

Althusser's rejection of the idea of an essence underlying the appearance of things has as its corollary the radical separation of a theoretical practice against and beyond appearances (and ultimately 'beyond' the social formation) legitimated by its own internal coherence and rigorous systematic procedures. We have suggested that this is no less trapped in a narrative logic which aims to reveal a finished 'truth' than is the object from which it takes flight. But a counter-emphasis which gradually developed in Althusser's work insists on the continuing tripartite constitution of each Generality or theoretical 'set' as a discursive domain. This is the massively significant insight obtained at the expense of the blindness of a 'theoreticism'--that the narrativisation of staggered systems of signification meets Jameson's criterion for identificatory transcoding: 'the invention of a set of terms, the strategic choice of a particular code or language, such that the same terminology can be used to analyse and articulate two quite distinct types of object or "texts", or two very different structural levels of reality'.⁴ The 'helix' is the closest the spatial root metaphor can come to suggesting this refusal of both prior essence (given) and final knowledge (installed) in

favour of levels which remain at a fixed distance from each other while demonstrating, ultimately, their continuity.

It is necessary to return to the question of 'layers' as posed in Chapter 3 and the suggestion there that, properly grasped, the hermeneutic code 'opens up...a space in which the fabula occupies shifting positions and with it the 'truth' which the material is relied upon to offer up'. With the rejection of essentialism and theoreticism, this can be reinstated as the key proposition of the thesis. We have to consider the distinction between expressive and structural causality in terms of the problematic of 'inner' and 'outer' form with which this work began if the matter of 'shifting positions' is fully to clarify itself. The fabula which has been resisted here is that of the 'flight of the dreamer': the supposedly archetypal escape of the American hero from 'society' to 'nature' in search of regeneration. The strong precursor here is not Turner but Emerson.

10.2 The lesson of power

What is particularly striking about Emerson's essay on nature is not so much the hardly unexpected insistence on the individual at the centre with everything else arrayed about as 'property', 'dowry' or 'estate', but the barely repressed anxiety that the movement might reverse itself, that there might be an overpowering influx --that rather than the possessive individual taking up the world as his own, the world will intrude upon the individual, will exert a determinative and possessive influence.⁵ When he asks 'can we separate the man from the living picture?' he has immediately to make clear that the inseparability is in terms of the individual's priority and the picture's reflection of it and does not entail a dispersion of the human into nature. ('Does not the New World clothe [Columbus'] form with her palm-groves and savannahs as fit drapery? ... A virtuous man is in unison with her works, and makes the central figure of the visible sphere.'⁶) That this insistence and its repressed anxiety anticipate the problematic of 'inner' and 'outer' form raised in Part I is clear from Emerson's treatment of language: 'The use of the outer creation is to give us language for the beings and changes of the inward

creation.' Thus from wind to Spirit: 'Every natural fact is a symbol of some spiritual fact. Every appearance in nature corresponds to some state of the mind, and that state of the mind can only be described by presenting that natural appearance as its picture.'⁷ There is here the 'lesson of power':

From the child's successive possession of his several senses up to the hour when he saith, 'thy will be done!' he is learning the secret, that he can reduce under his will, not only particular events, but great classes, nay the whole series of events, and so conform all facts to his character. ...More and more, with every thought, does his kingdom stretch over things, until the world becomes, at last, only a realized will, --the double of the man.⁸

The anxiety persists, however, as to what 'is caught by man and sinks into his soul',⁹ what there is of an influx set against the individual's outward projection of his states of mind ('caught' as a disease is caught, perhaps, like influenza -- influentia, influence):

Who can guess how much firmness the sea-beaten rock has taught the fisherman? how much tranquility has been reflected to man from the azure sky, over whose unspotted deeps the winds forevermore drive flocks of stormy clouds, and leave no wrinkle or stain? how much industry and providence and affection we have caught from the pantomime of brutes?¹⁰

Such un-spiritual winds and that last uneasy coupling of virtues and 'pantomime' reveal the very repressed anxiety of the question; its threat that the individual might be the double of the world, an effect of its structure and, therefore, open to the brutish as well as the noble. Indeed Emerson's 'man' is in retreat, his lesson of power reduced to the dimmest of memories:

He filled nature with his overflowing currents. ...The laws of his mind, the periods of his action externalized themselves into day and night, into the year and the seasons. But, having made for himself this huge shell, his waters retired; he no longer fills the veins and veinlets; he is shrunk to a drop. He sees, that the structure still fits him, but fits him colossally.¹¹

This anxious nostalgia for an Edenic 'fit' or consonance of 'inner' and 'outer' form, of self-reliance and structure, is 'resolved' by interpreting influx not in terms of an invasive structure which de-centres and disperses the individual but rather as 'spirit' which suddenly appears to be emerging through the individual. Behind the local instances of natural symbolism (the rock, the snake, light and darkness....) is the ultimate spiritual fact, Spirit itself: 'And

man in all ages and countries embodies it in his language, as the FATHER.¹² This presence, the symbolic breath of the Father, effects a re-centering of 'inner' form in a position of priority and authority: the individual is its 'alembic'. The colossal structure is now

the great organ through which the universal spirit speaks to the individual and strives to lead back the individual to it. ...That spirit, that is, the Supreme Being, does not build up nature around us, but puts it forth through us, as the life of the tree puts forth new branches and leaves through the pores of the old.¹³

The anxiety is displaced, therefore, into the relationship of the individual to the voice of the Father: with our post-Freudian keenness we are alert to the beginnings of a family romance in which the symbolic mediation between subject and 'nature' (desired as the space into which the subject may 'stretch' and expand; resisted as the structure which threatens to subsume the subject) highlights the ambiguity of 'thy will be done!' in the lesson of power. Who is it that learns the lesson and who actually has the power? -- the space into which the precociously self-reliant individual wants to expand, in Emerson's scheme,

may already be occupied. This is what Harold Bloom calls 'Emerson's beautiful confusion' -- it arises from 'his inner division on the burden of influx, at once altogether to be desired and yet altogether to be resisted'.¹⁴

That the persistent stutter of much interpretation of American fiction is to see the woman as the embodiment of a disturbance, a 'fall', is hardly surprising given Emerson's apparent beginning here on the establishment of a family romance as the 'resolution' of a deeper anxiety. 'Woman' can be desired and resisted simultaneously as long as the voice of the Father intervenes. It was suggested in Part I that genre as an exemplary domain of the practico-inert (that is of subjectivity and structure interbedded as moments of a process) dramatises the fundamental anxiety which informs such a displacement: the agon of originality and influence (of creative self-reliance and the available structure of a genre). Clearly the Oedipal resolution is one way of arresting the contradictions, of stemming the anxiety. But, for Emerson, the pneuma is not simply the original and inviolable voice of the Father; such an

embodiment is credited, after all, to others 'in all ages and countries'. Emerson sees it as an imaginative power which may be characterised in this way in the beginning but which must also then be allowed a free course, particularly by and through poets, écrivains perhaps, (the rebellious sons of the Father, as it were) in order to replace fidelity with re-beginnings or transumptions: 'There are innocent men who worship God after the tradition of their fathers, but their sense of duty has not yet extended to the use of all their faculties. ...Build, therefore, your own world.'¹⁵ And this imperative is not simply for a single revisionary extension of the sense of duty achieved over and against an original Father: the pneuma is a chain of such re-beginnings (including the poet's and the reader's; Bloom-- 'Reading a transumptive chain becomes necessarily a critical exercise in transumptive thought'¹⁶).

The chain may only seem to come down to the present, so to speak, as fidelity to the masculine ethos originated by the Father ('That man was my bible', says Peckinpah of Hemingway¹⁷): the ethos 'of rod and gun' on which Fiedler concentrates:

There is no question about junior's allegiance; through Nick, the boy Hemingway always in some sense remained, the choice is made once and for all in a short story called 'The Doctor and the Doctor's wife': '"Your mother wants you to come and see her", the doctor said. "I want to go with you", Nick said.'¹⁸

Through rod and, mostly, gun the self-reliant individual projects his will: in cinema the self-consciously Turnerian hero such as Shane (again there is no question about the boy's allegiance) and the monstrous apotheosis of the type in 'Dirty' Harry. But there is always also the anxiety; the sense in which 'Build, therefore, your own world' is bound to find itself built around, opposed by the confines of the already built--'nature' itself but also form, context, structure in every sense, including the very tradition of allegiance to the fisher-hunter-Father of American imagination. There are then, simultaneously, the weak or arrested transumptions (the rod and gun, the journeys down the river and into combat, the endless repetition of 'I want to go with you' . . .) and the strong transumptions, the re-beginnings which are genuinely Emersonian in their revisionary de-construction of what has gone before (including the 'Emersonian'),

Over and against the projection of the masculine principle into 'the territory' (Huck Finn) of realized will and its celebration initiated by Turner, there is the massive introjection, the sense of which gives Emerson's writing its quality of anxiety (and, as Anita Kermode puts it, a characteristic mode for the writer--'Emerson departing, splitting'¹⁹). The following is from one of Emerson's addresses to students (at a time when his thinking is most troubled) and is particularly suited, therefore, to marking the contrast with Turner's neo-Emersonian view of nature's happy service to the will of the constructive and competitive individual (see Chapter 1):*

Let him beware of proposing to himself any end. Is it for use? nature is debased, as if one looking at the ocean can remember only the price of fish. Or is it for pleasure? he is mocked: there is a certain infatuating air in woods and mountains which draws on the idler to want and misery. There is something social and intrusive in the nature of all things; they seek to penetrate and overpower, each the nature of every other creature, and itself alone in all modes and throughout space and spirit to prevail and possess.²⁰

* pp.38-40 (Volume 1)

Thus 'all things are mixed' and the strongest poet can only hope to be 'a sort of bright casualty' of this.²¹ (And Anita Kermode suggests something of the transumptive chain from this point; the 'splitting of the ego that, when it is developed within the framework of narrative fiction, by Poe or Melville or Hawthorne, can look distinctly pathological'.²²)

Paul Seydor does not view Peckinpah as a bright casualty in this sense but locates him in a continuous line of succession through which is gradually emphasised and honed the essence of the precursor's ethos:

The works themselves [in the latest stages of transmission by succession] appear to be less controlled mostly because, in the absence of externally imposed restraints (that is, genteel proprieties), they are overtly volatile and explosive. The exploration of new states of feeling, awareness, and consciousness is unimpeded by the necessity to sprout what Hawthorne calls 'sweet moral blossoms', and the call of the wild and wilderness, the lure of the savage, is answered unashamedly, indeed enthusiastically and without apology. At the same time, however, there is a new moral imperative toward self-restraint (there being no other kind save conformity to a lifeless technocracy); and the search for what Mailer calls a new nervous system goes hand in hand with what Peckinpah calls 'the old cry for identity and purpose'. This quest is the twentieth-century equivalent to Emerson's retreat to nature in search of self, but now the villain that Emerson called society is much larger, more inclusive, and by several orders of magnitude more powerful... .²³

So the assumption continues that the flight to nature is a genuine rebellion against civilization, its constraining 'proprieties' now hardened into technocracy; yet as we have seen the very form of this 'flight' finds itself bound into the pattern of imitative desire which upholds 'society' through a displacement from political 'levels' onto familial. The patrilineal implication of the emulative movement from Emerson through Hawthorne, Melville, Hemingway and so on, clearly reflects the slide from a diachronic model of progression to a synchronic 'image' which may variously be read as the Oedipal resolution, the essence expressed at each link in the chain, the space of the endlessly repeated 'I want to go with you' where the 'I' is ultimately the position offered to the reading/viewing subject and the 'you' is ultimately the symbolic mediator, the 'Father' who authorizes the stability of the institutional and serial levels. It is to Seydor's credit that he half-admits Mailer's difference here, trying to assimilate it as a reaction to the increased power and inclusiveness of 'society'--in fact Mailer's texts increasingly put into question the

mirror-exchange between a privileged 'inner' and an 'outer' form and re-begin within the anxiety which is the very condition of this putting into question. (And at this point 'outer' form is not just 'nature' but the whole tradition--the weak transumptive chain--with the 'inner' essence that it offers to potential inheritors.) Mailer's texts suggest the existence of an 'unconscious', of a strong transumptive chain, of genuine re-beginnings which would make of the texts of Hawthorne and the rest something other than developing stages of transmission by succession of an essential masculine principle, a fabula of flight, a getting clear of civilization to find one's own anterior, natural self: 'Mailer . . . seems to want to suggest that this traditional dichotomy between nature and civilization which is so dear to American literature . . . needs to be questioned. Man does indeed despoil the beauties of nature . . . [but Why are we in Vietnam? (1967)] generates the further suggestion that the original prompting for this compulsion to waste substance was not brought by man into the unspoiled realms of nature but rather contracted there.'²⁴ 'Inner' form is reabsorbed by 'outer' (and for Mailer this is also, of course,

language itself); it becomes an effect of 'outer' form, of influence (it is 'caught' as Emerson puts it) -- the existence of the 'outer' form in its effects is the only interiority. The 'original prompting' is located not in an anterior self but in the 'outer' form; there is no detectable centre in the wilderness and, for Mailer, this culminates in Ancient Evenings (1983) where the 'self' is literally consigned to re-beginnings and to a decentering play of forces: '...fierce forces are my state. I do not know who I am. Nor what I was. ...Whether I am . . . the creature of our twice seven separate souls and lights, I would hardly declare...'.²⁵

Against such mutability, the hero or auteur as the locus of a largely stable consonance of 'outer' and 'inner' is implicated in a rhetoric of spatiality where identity, as the 'meaning' summoned out of surfaces, is never seriously in question. The centripetal conversion of 'outer' form to anterior self operates at several levels: individual and nature, character and analogous landscape (Kitses: 'the terrain is so coloured by the action that it finally seems an inner land-

scape'), hero/star/auteur and the 'body' of films, and more generally the inner essence to which the whole is reducible in the model of expressive causality:

Here was a model which made it possible to think the effectivity of the whole on each of its elements, but if this category--inner essence/outer phenomenon--was to be applicable everywhere and at every moment to each of the phenomena in the totality in question, it presupposed that the whole had a certain nature, precisely the nature of a 'spiritual' whole in which each element was expressive of the entire totality... .

If the whole is posed as structured, i.e., as possessing a type of unity quite different from the type of unity of the spiritual whole, this is no longer the case: . . . on the contrary, it implies that the structure is immanent in its effects, a cause immanent in its effects in the Spinozist sense of the term, that the whole existence of the structure consists of its effects, in short that the structure, which is merely a specific combination of its peculiar elements, is nothing outside its effects.²⁶

An effort has been made throughout this thesis to grasp 'effects' in this sense but it has necessarily entailed a criticism of the Althusserian tendency to separate and elevate the axiomatic 'scientific knowledge effect' to the status of essence in another place. We have focussed instead on the concept of mediation and attempted to expand it in such a way as to find it compatible with the Spinozist model of

structural causality. We can now return to the matter of textual 'levels' and mediation in order to draw together the questions raised in Chapter 1, the diachronic focus of Chapter 2 and the synchronic focus developed in Part III.

Such a convergence of structural forces, within the textual 'ocean' of causality, is enabled by the invention, as already established, of a spatial code which allows the articulation of theoretical practice and narrative understanding. This invention has been based on Althusser's Generalities which we have pictured as staggered systems:

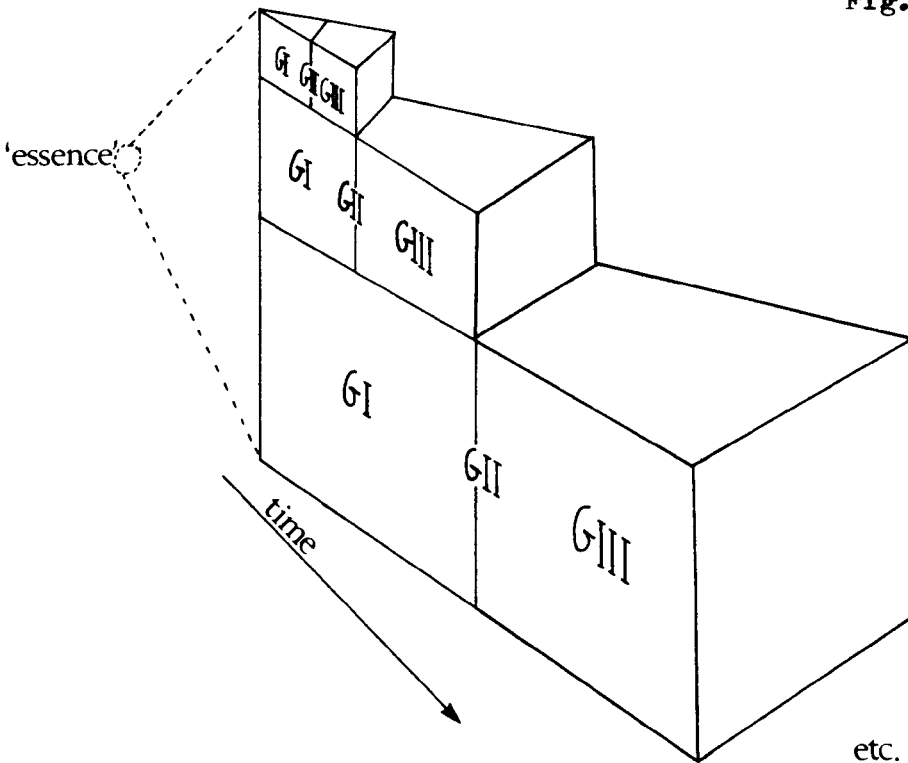

Fig. 59.

In this bare schematic representation a notion of anterior 'essence' holds the ideological axis in place insofar as the key ideological system against which theoretical practice operates has been identified as the model of expressive causality. But it has been suggested that, over and against the continuing 'deposit' of GIs, the anticipation of a final GIII which has a 'scientific' status (in that it has broken from ideology once and for all) is in fact the anticipation of another 'essence'. In this sense it is necessary to shift emphasis away from both GI and GIII onto GII, the means of actual theoretical work as distinct from the raw material on which it works or the results of its work. GII is now understood to be a form of mediation insofar as the system of structural causality with which it works is a code which allows various distinct levels of reality to be articulated and analysed.

The principal concern here, however, has been with the specifically narrative qualities of this spatial code. In these terms GII trans-codes as diachronic mediation and the spaces of GI and GIII constitute the 'spatial text' which is organised by the forms of narrative understanding:

in short we can usefully consider GI to be the textual space organised by $fx(a)$, the disturbance around an initial actantial term, while GIII is the space re-stabilised by $fa^{-1}(y)$, the inversion produced through the actant (b), (in simple stories and myths usually a hero but we have found that in more elaborate narratives certain qualities are passed to the hero by others implicated in the 'splitting' of the actantial role): the mediatory function attached to (b) is the narrative realisation of GII, the means of production of narrative 'knowledge'.* Where the 'volume' of GIII was not subdivided in our initial consideration of 'knowledge' production, the narrative model has allowed for three possibilities --the cyclical, the loss and the gain. (See over.) It has been necessary to add 'depth' to these representations because of the distinction established between diachronic mediation and the synchronic memory-pictures which it produces: the latter appear as the three planes identified in 'depth'. We have understood these synchronic planes to be organised along the lines of the Greimassian semiotic rectangle with the modification that 'woman' as a term tends to subsume the

*with the interesting consequence that the means of production, chiefly here the instruments of production, become certain narrative and theoretical 'tools' for the representation of 'sexuality', for the fixing of difference and assertion of Sameness, which pass through (as instruments through a body) the 'woman'; see for example pp.573-80

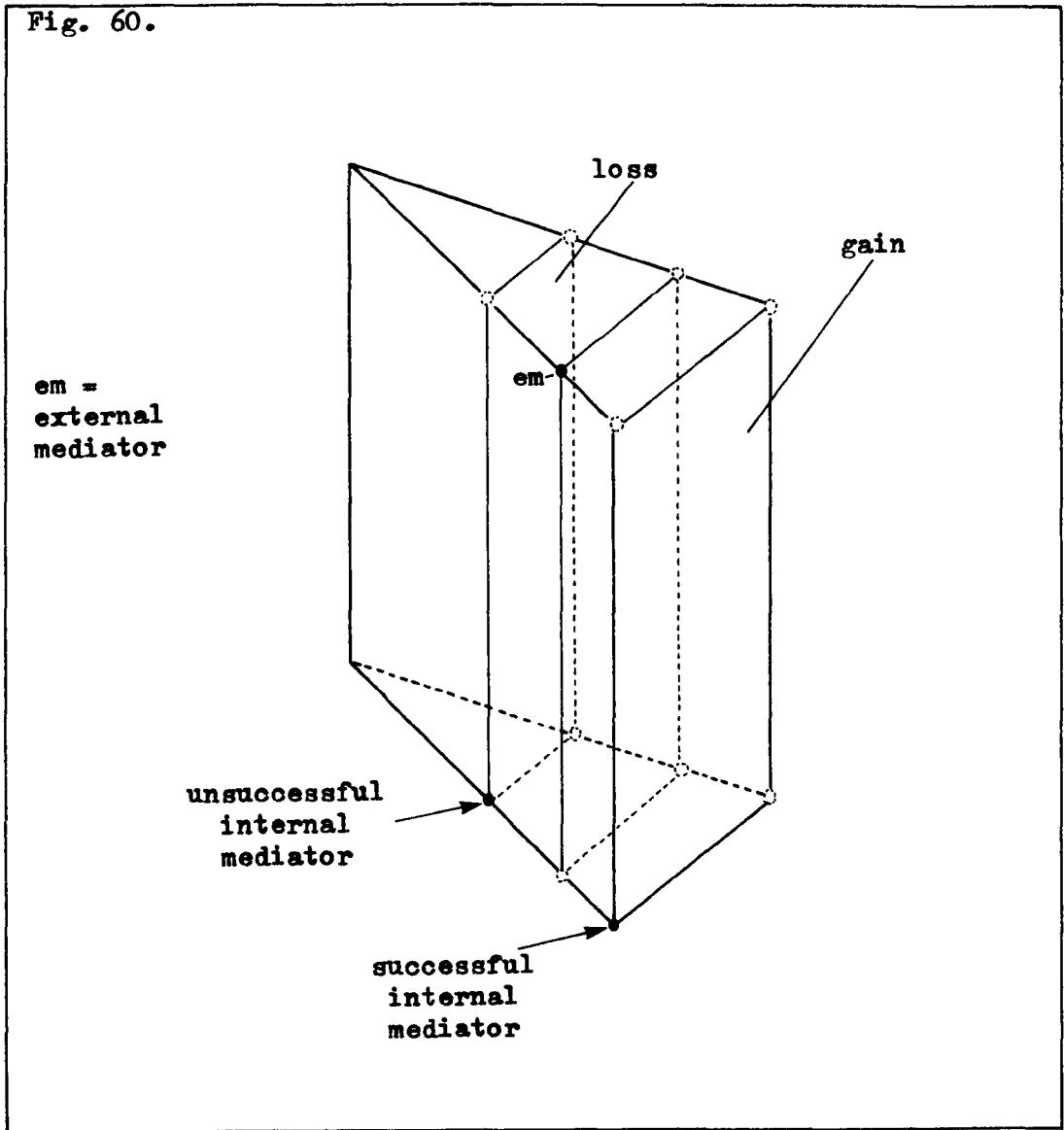

two terms on the right of the rectangle while the two on the left typically constitute the synchronic axis of mediation. Representing it in the form above, however, forces us to remember that this subsumption is a form of ideological closure and that it has to be re-articulated in semiotic terms if this closure is not simply to be repeated theoretically.

It has also to be stated quite unequivocally that the risks involved in the baroque elaboration derived from drawing together the various spatial analyses accumulated in the course of this study are being deliberately brought to the fore: it has been part of the thesis that the imperious drive to authoritative 'knowledge' is deluded and must be folded back into its 'object'. The way in which diagrams appear to hold in place a field of potential ambiguity and indeterminacy stems from their spurious authority as a detached metalanguage; as was argued in Chapter 3, the metalingual function, the discourse of knowledge mirroring the discourse of disclosure, cannot sever itself in this way from its textual 'object'. If we now rediscover in the convergence of these various diagrammatic summaries a density which seems to undermine their supposed revelatory intent, it is only because the 'object' is re-claiming them.

In setting narrative functions in this kind of 'nonreal' space we inevitably raise the question of the relationship of this space's geometry to the 'real' spatial qualities of

mise-en-scene. As a subsystem of the film's total system or form, narrative charts a course for the viewer through the mise-en-scene, which typically reciprocates by furnishing recurrent motifs (significantly repeated compositions, objects, colours, sounds, actions, lighting patterns, etc.), themselves organised by the other principal subsystem, the stylistic. But our 'nonreal' spatial organisation takes into account the fact that the audience's absorption in the film (under pressure to subject themselves pleurably to the succession of screen events, a pressure to go with the flow, to let go of their hold on actuality, the actuality of sitting serialised before the screen) is largely a matter of finding effortlessly the 'ways in' for the meanings which are produced in and through the film as a total system. Where the 'real' spatial qualities of mise-en-scene work to efface the construction of these 'ways in', to have the audience follow them as a matter of common sense into the imaginary space, it is necessary to use a 'nonreal' space, a semiotic spatial analysis, in order to learn about the effaced features of the mise-en-scene's spatial (and matched temporal)

'reality'--about the textual space of which its representational space is an effect.

The organisation of behaviour according to certain kinds of performance has been a significant point of contact between mise-en-scene space and the spatial code invented in order to connect film form and social reality; in short it will allow an interpretive movement from imaginary space (mise-en-scene) through proximate space (in front of the screen, organised by seriality) to macro-space (everyday life).²⁷ For our purpose the latter consists in the various mental 'maps' which the subject has access to in order to relate to 'society': including a sense of geographical location, of social hierarchy (upper/middle/lower), of position on a spatialised (left/centre/right) political spectrum, of available routes ('up' through a career, 'dropping out' . . .), of knowing one's place, and so on. We will use a specific version of such a 'map' in order to complete the progressive interpretive movement of the thesis. The fulcrum for the whole movement remains the body in front of a screen and the dense convergence there of forces and investments. The body

in front of a screen, so 'naturally' and unproblematically, can join the other 'insignificant' techniques identified by Bourdieu as carrying, in mnemonic form, the whole weight of these forces and investments:

The principles embodied in this way are placed beyond the grasp of consciousness, and hence cannot be touched by voluntary, deliberate transformation, cannot even be made explicit; nothing seems more ineffable, more incommunicable, more inimitable, and, therefore, more precious, than the values given body, made body by the transubstantiation achieved by the hidden persuasion of an implicit pedagogy, capable of instilling a whole cosmology, an ethic, a metaphysic, a political philosophy, through injunctions as insignificant as 'stand up straight' . . .²⁸

As manipulations of body experience, watching TV or going to the pictures have this quality of specious ineffableness that makes the activity seem to mean something over and above the material viewed or the supposedly private pleasures taken; a ritualism which is accepted as entertainment (Hollywood genres, stars, heroes --the first cinema, with its TV reflections such as the cop show) or art (oeuvres, auteurs--the second cinema, and on TV the 'play' or the 'serious' film).²⁹ That one should enjoy oneself

in this way or that one should appreciate the stylistically personalised variants are injunctions (in support of quasi-unities) in deep complicity with the screen's work on the body; work which, in dominant cinema, is a structural exercise in fitting the body into the social formation -- Bourdieu: 'It is in the dialectical relationship between the body and a space structured according to the mythico-ritual oppositions that one finds the form par excellence of the structural apprenticeship which leads to the embodying of the structures of the world...'.³⁰ To grasp such a space as textual in the case of the cinematic (between the actual spatial coordinates of screen and viewer and including its invasion of the house via aerial, tape and cable) we have needed to refuse the imaginary mise-en-scene space in favour of a semiotic spatial analysis of the text in terms of its narrative functions and the memory-picture constituted by its structuring oppositions (the invested Greimassian rectangle). The apprenticeship is in serial responsibility; seriality purged of 'deviance', separation intensified to the point of delicate balance where the illusion

of unity still holds but separation has gone so far that there is a serial inability to realise any other unity. The institutionalised social formation of controlled consumption is always looking for this point. But having identified this hidden curriculum the interpretive movement folds back on itself to reconsider desire where once it questioned 'entertainment' and 'art'. Logically then the movement towards a satisfactory third term re-encounters mise-en-scene and the 'given' effects of representational space.

10.3 Instrumental reason and desire

Homo economicus -- if Robinson Crusoe's embodiment of a world less interested in desire than in need and achievement, contracts, property and the economic motive, remains a powerful symbol then Cable Hogue is one of the most striking inheritors of its influence.³¹ Just as newcomers to the island had to acknowledge Crusoe's sovereignty so Cable demands payment for the use of 'his' water and when he looks for financial backing in town he is so clearly the stuff of economic individualism that the banker gives him, without collateral security, more than he asks for.³² Yet Cable does not prove to be another Tom Dunson (Red River, 1948); he does not build an empire from his discovery, nor does he live happily ever after, like Ringo, with the whore driven out of town by the 'good' people (Stagecoach, 1939). And neither is sex subordinated to business as for Crusoe; that Hildy is a prostitute serves precisely to liberate her friendship with Cable from such subordination--the issue of money is confronted and transcended. She is not dependent on Cable's success (as would be the conventional Western woman) and her own superficial show of economic

individualism is an ironic comment on the type; in fact Hildy convincingly embodies a challenge to the economic determination of personal relationships by taking it to its limit, as prostitution does, and then (rather than being reclaimed by the hero) finding genuine possibilities beyond. Economic individualism is a cocoon, its counterfeit luxuries a silken sheath from which Hildy appears able, confidently and 'naturally', to emerge; her song is 'Butterfly Morning'.³³

Cable, on the other hand, tends to strip economic individualism down to its most basic psychological orientation, the pursuit of self-interest. He seeks to capitalize on his success in the most obsessive way--to prove his absolute individualism through revenge on those whom he once trusted and who betrayed him. This is not the whole story for Cable but it takes up enough of his energy and character for his death under the wheels of the first automobile he sees to have an extraordinary resonance in relation to the classic formulation of instrumental reason as the formal means-end rationality characteristic of economic individualism. Adorno and Horkheimer

write: 'Thinking objectifies itself to become an automatic, self-activating process; an impersonation of the machine that it produces itself so that ultimately the machine can replace it.'³⁴ In the revenge story, the basic fabula, Cable's thinking becomes automatic and self-activating in this way; the driverless automobile is about to complete the revenge, which Cable has abandoned half-done, when Cable pushes his surviving rival out of the way and becomes himself the victim of the revenge-machine, now totally depersonalised. That rather than ultimately capitalizing on the instrumental reason invested in his enterprise Cable instead becomes its victim, is a difference mediated by Hildy (with support of a kind from Joshua the preacher).

Hildy's material aspirations, to go to San Francisco and marry well (for comfort and security), have about them a casualness that suggests they are only the epiphenomena of a fundamental hedonism which prevents her sharing in Cable's obsessive economic individualism and in the inevitable trajectory of instrumental reason which makes Cable's solitary existence

finally an allegory of the social process rather than a flight from it (hence the consecratory flag-raising): 'He defines himself only as a thing, as a static element, as success or failure. His yardstick is self-preservation, successful or unsuccessful approximation to the objectivity of his function and the models established for it.'³⁵ Cable's insistence to Joshua, the self-conscious parody of Puritan individualism, that his plan for revenge is not a 'passion' becomes, therefore, more accurate than it might seem at first: it is the testimony of Cable as a static element, like Crusoe on his island, embodying a passionless and conventionalised means-end rationality. His 'freedom' is entirely circumscribed. He is confined to the small area of desert made habitable by the water-hole and is integrated as a functionary into the growing system of transportation which anticipates the mechanised arterial organisation of the industrial state. If, when he dies, Cable is on the verge of opting out, of resisting the inevitable transformation of his individual 'success' into standardised efficiency, it is through the influence of Hildy's embodiment of something else.

When Hildy is 'asked' to leave by the townspeople and arrives at Cable Springs, her introduction into the mise-en-scene there is established in terms of physical change to the whole spatio-temporal environment. As she watches, Cable in speeded-up motion frantically tidies the cabin. But more than this she effects a change, or the promise of a change, in the very way the mise-en-scene is structured: her arrival and conversation with Cable are offered in a conventional shot-reverse shot sequence, but Cable's eruption into speeded-up motion is from a frame containing them both, Hildy's stillness there contrasting with Cable's effervescence. The shot-reverse shot pattern culminates in Hildy's beautiful appearance in the lighted doorway of the cabin while Cable waits outside. 'Lady, nobody's ever seen you before', Cable tells her and the look of the camera is identified with his point of view. But Cable then moves into the frame with Hildy, splitting the spectator off from his subjective position as the door closes. The subsequent morning scene, with the cabin's space now neat and homely, sees Hildy's figure dissolve into a

shot of the water channel outside. The camera tilts slowly down with the flow of water and pulls out to find Hildy catching it in a bucket as she sings her song, 'Butterfly Morning'. The repositioned frame, in a continuous shot, discovers Cable at the other end of the flow transferring water from the spring into the channel. As Hildy's song approaches its final chorus Cable joins in, now bathing her as she lies blissfully in a huge water barrel. But the scene is interrupted by the arrival of the stage-coach and a series of aggressively abrupt cuts to the voyeuristic looks of the driver and passengers as the naked Hildy effects a speeded-up disappearance.

The entire sequence, centred on the flow between Hildy and Cable as an alternative to the disjunctive shot-reverse shot pattern, is framed by the two instances of speeded-up motion, suggesting a radical desynchronisation between two 'realities'. (As the speeded-up effect of old silent films indicates, not their actual condition, but a desynchronisation.) This desynchronisation is anticipated, when Cable first sees Hildy in town, by the fragmented

cutting through which her body interrupts the spatial stability of the scene, culminating in the additional effect of an animated Indian who grins at Cable from a dollar bill. What Hildy throws out of synchronisation, in order to suggest the possibility of a more unified mise-en-scene, an image of flows rather than breaks, is the conventional cinematic code of alternating vision. By her presence she is able, insistently, to reveal its inherent instability, throwing it off balance and into fragmented cutting, patent artificiality, speeded-up motion and so on.* Cable is only briefly allowed to settle in her space, after his spurt of resynchronising motion, but the fact that it is a space defined by the time of a song, a narrative interlude, suggests its fragility. Hildy leaves Cable Springs. She leaves Cable to his revenge, his fabula.

Instrumental reason which now becomes the final clarification of the first term (ritualism, external mediation) in the structure of oppositions with which we have been working, is rooted, as Adorno and Horkheimer contend, in the Enlightenment programme to establish

*that this is achieved, in part, within a representation of domestic pleasure and satisfaction which reproduces the familiar oppressive positions is precisely the point; see below, pp.679-80

sovereignty over nature; to set in relation to nature the rational essence of man as 'the central figure of the visible sphere' in Emerson's words. That this dominant ratio should have consequences for the material studied here is hardly surprising: as 'the fully enlightened earth radiates disaster triumphant',³⁶ the culture industry becomes increasingly the most important and pervasive arterial organisation where once stage-lines, railways and roads carried the traffic in commodities and information. Adorno and Horkheimer themselves trace the regression of enlightenment to ideology in their influential essay on the culture industry, which is too often, however, taken out of the context of their overall attempt to focus understanding 'upon the nexus of rationality and social actuality, and upon what is inseparable therefrom--that of nature and the mastery of nature'.³⁷ Their hope, their version of scientia intuitiva, is for enlightenment's self-examination in order to recognise, deconstructively we might say, that myth and domination deeply imbue enlightened thought.

Instrumental reason (or, as Marcuse calls it, 'technological rationality'³⁸) as the form of enlightenment, bears responsibility for the fact that 'ruthlessly, in despite of itself, the Enlightenment has extinguished any trace of its own self-consciousness'.³⁹ The contemporary post-individualistic social formation holds to its imaginatio, the representation of an individualism which embodies the structure of projection essential to an instrumental reason that is now the characteristic feature of transnational corporations and their functioning in the world.

Instrumental reason is based on a disjuncture between 'inner' and 'outer' form, subjectivity (as form rather than content) and nature. This disjuncture can then only be managed by a contrived adaptation, an imaginary consonance achieved between an essential subjectivity which steals a formal stability from nature and then turns around to dominate a nature now subsumed under categories corresponding to the ends of an 'original' subjectivity -- 'God' or, as we have suggested, inheritors in a weak transumptive chain descending (Odysseus,

Crusoe . . .) to the bathetic effort to set up sovereign heroes and auteur-heroes within a mass culture. Sovereignty of 'inner' form over 'outer' and hard-shelled resistance by the former to the potentially de-centering influence of the latter (based on a prior separation of 'inner' and 'outer'), is the central structure embodied by the impermeable hero, the impersonation of the machine in the external performance (whether of an external or internal mediator). Similarly the anterior auteur who is not simply the effect of Intentionality as a feature of the textual space, is a result of the extension of the model of expressive causality with its emphasis on a centripetally-located essence. The domination of the 'outer' by a secure centre is the general theme. The alternative is an organic adaptation to a nature the presence of which in its effects is the only interiority. Interiority, in this sense, is referred to by Adorno and Horkheimer as 'mimetic behaviour proper' and its repression as working against the longing for 'direct unification with circum-ambient nature'.⁴⁰ Nature then becomes the unconscious, (unless also in pre-capitalist

enclaves of the South instrumental reason has not fully encroached upon nature). The account of this process given by Adorno and Horkheimer is such a crucial framework for much of this study, with its identification of certain forms of the 'organized control of mimesis', that it is worth referring to in some detail:

Civilization has replaced the organic adaptation to others and mimetic behaviour proper, by organized control of mimesis, in the magical phase; and, finally, by rational practice, by work, in the historical phase. Uncontrolled mimesis is outlawed. ...For centuries, the severity with which rulers prevented their own followers and the subjugated masses from reverting to mimetic modes of existence, starting with the religious prohibition on images, going on to the social banishment of actors and gypsies, and leading finally to the kind of teaching which does not allow children to behave as children, has been the condition of civilization. Social and individual education confirms men in the objectivizing behaviour of workers and protects them from reincorporation into variety of circumambient nature. ...'Recognition in the concept', the absorption of the different by the same, takes the place of physical adaptation to nature. ...Society continues threatening nature as the lasting, organised compulsion which is reproduced in individuals as rational self-preservation and rebounds on nature as social dominance over it. ...Those blinded by civilization experience their own tabooed mimetic features only in certain gestures and behaviour patterns which they encounter in others and which strike them as isolated remnants, as embarrassing rudimentary elements that survive in the rationalized environment. ...Of all the senses, that of smell--which is attracted without objectifying--bears clearest witness to the urge to lose oneself in and become

the 'other'. As perception and the perceived-- both are united--smell is more expressive than the other senses. When we see we remain what we are; but when we smell we are taken over by otherness. Hence the sense of smell is considered a disgrace in civilization, the sign of lower social strata, lesser races and base animals. The civilized individual may only indulge in such pleasure if the prohibition is suspended by rationalization in the service of real or apparent practical ends. The prohibited impulse may be tolerated if there is no doubt that the final aim is elimination--this is the case with jokes or fun, the miserable parody of fulfilment. ...The civilized man 'disinfects' the forbidden impulse by his unconditional identification with the authority which has prohibited it; in this way the action is made acceptable. If he goes beyond the permitted bounds, laughter ensues. This is the schema of the anti-Semitic reaction. Anti-Semites gather together to celebrate the moment when authority permits what is usually forbidden, and become a collective only in that common purpose. Their rantings are organized laughter. ...

Anti-Semitism is based on a false projection. It is the counterpart of true mimesis, and fundamentally related to the repressed form; in fact, it is probably the morbid expression of repressed mimesis. ...Impulses which the subject will not admit as his own even though they are most assuredly so, are attributed to the object--the prospective victim. The actual paranoid has no choice but to obey the laws of his sickness. But in Fascism this behaviour is made political.⁴¹

When we understand the audience serialised by the screen as both subject to a false projection and celebrating the repressed desire awakened in order to be re-directed, the immense significance of this analysis for our purposes is clear.

Mimesis 'proper', which underlies the more familiar

mimetic modes, may be grasped in terms of Spinoza's concept of nature as active (natura naturans), as conceived through itself, through the interiority which is its presence in its 'attributes' or effects. Instrumental reason would find its object, in Spinoza's terms, in nature as passive (natura naturata)--the created system (hence the metaphoric slide into notions of analogous landscape or the oeuvre).⁴² What Adorno and Horkheimer identify here is the steady reification of natura naturata as 'outer' form to be dominated and the concomitant repression of natura naturans which becomes the unconscious. Manifestations of the latter are found in the occasional 'gesture' or 'pattern', as in the tabooed pleasures of smell, powerfully suggesting here the interpenetration of perception and perceived which defines natura naturans (an interpenetration for which a general theoretical framework is offered in Chapter 5, section 3, above).*

It is here that the generalizable significance emerges: even in the most brutally repressive manifestation of instrumental reason

* see in particular pp.375-79

the 'prohibited impulse' will be awakened in the very act of managing it. The degraded forms of instrumental reason are 'fundamentally related' to the repressed impulse, to desire. Anti-Semitism, like the disinfecting of smells, depends primarily not on disgust but on desire; in this case on an awakened sense of the injustice of a whole class system. The false projection of this injustice onto the Jews controls or manages the awakened desire. In the terms of the present study, the protopolitical desire for deserialisation is aroused in the very form of the screen experience in order to be managed in a structurally similar way; by projection onto, most often, the represented body of 'woman' and, in general, into the sexual grid of Oedipal management. The object of desire is then discredited in ways roughly analogous with the laughter at the Jew's expense or the disinfecting of the specific smell (and we shall identify more clearly the paranoid features of this structure). What must be held onto, though, is the fact that the impulse, the desire, is genuine and can only be managed by simultaneously awakening it. Adorno and Horkheimer summarize this dialectic of desire and management-by-violence:

The rights of man were designed to promise happiness even to those without power. Because the cheated masses feel that this promise in general remains a lie as long as there are still classes, their anger is aroused. They feel mocked. They must suppress the very possibility and idea of that happiness, the more relevant it becomes. Wherever it seems to have been achieved despite its fundamental denial, they have to repeat the suppression of their own longing. Everything which gives occasion for such repetition, however unhappy it may be in itself--Ahasver or Mignon, alien things which are reminders of the promised land, or beauty which recalls sex, or the proscribed animal which is reminiscent of promiscuity--draws upon itself that destructive lust of civilized men who could never fulfil the process of civilization.⁴³

It is possible, therefore, to think of mass culture as a whole as containing a 'steady state' of desire along lines similar to Bateson's description of Balinese culture with its 'lack of climax', although clearly there are innumerable false climaxes within the various structures into which desire is displaced.⁴⁴

We have taken desire to be the contrary of instrumental reason insofar as the latter, as means-end rationality, directs itself to a definite end by precisely calculated means while the former exactly undermines such calculation by the fact that the object of desire only exists when it is already lost (the pleasures of smell,

the promise of happiness. . .) and this loss will still be contained within any subsequent 'satisfaction' (perfume, anti-Semitism . . .): hence the desire for deserialisation as formulated here has no content in the sense of an 'end'--it emerges from subjectivity caught up in seriality and only then finds itself attached to an object. Often, in the case of the screen and the cinematic, to 'woman' as pre-Oedipal wholeness only to be repulsed by the sexual grid, the Oedipalisation, as we have seen. If we are to draw together the relations and structural dimensions possible through the interaction of these terms it will be necessary to add some detail to the constitutional model developed from the Greimassian rectangle.

Claude Bremond introduces a set of subtle and suggestive modifications to the model in order to make its synchronic status more compatible with the diachronic processes of narrative: 'There are two types of processes: on the one hand, those that tend to modify the situation; on the other those that tend to preserve it. According to another division, each time that these processes affect human characters

...they are presented by the narrative as being favourable or unfavourable to these characters'.⁴⁵

These distinctions form the following rectangle:

Fig. 61.

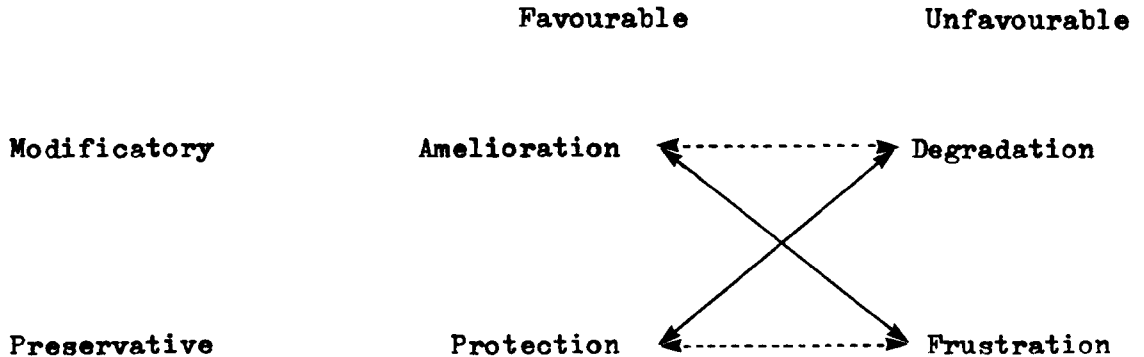

Bremond makes this formal investment of the constitutional model even more capable of careful and significant distinctions among various narrative possibilities by proposing that there is a second set of terms running counter to this one, representing the kind of dense interaction of semiotic constraints to which such schemes all too often seem to be inadequate. Introducing the terms 'instrumental reason' and 'desire' we obtain the following:

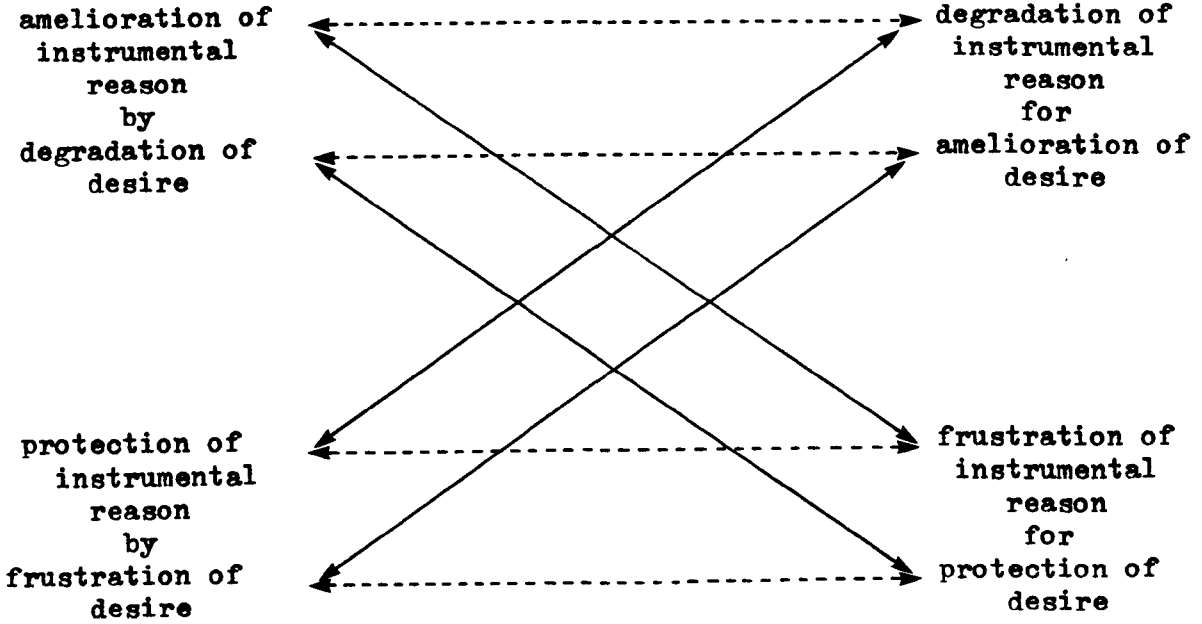

Fig. 62.

If we consider the placement of characters within the structuring oppositions of The Ballad of Cable Hogue we initially obtain this:

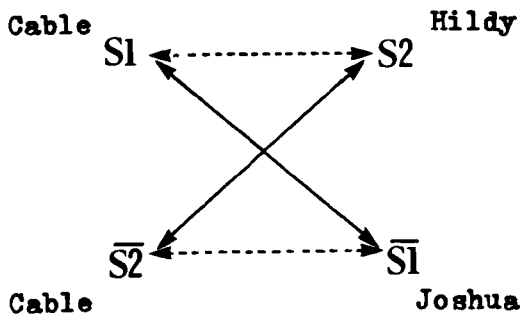

Fig. 63.

The narrative begins with Cable's obsessive demonstration of instrumental reason, the initiation of the revenge story as the means-end rationality which explains his attachment to the waterhole. While the forces of the market agglomerate round Cable's economic individualism (the banker, the stage-line) Hildy, with Joshua's help, mediates Cable's repositioning at $\overline{S2}$ where he is still implicated in the dominant rationality but is about to surrender his stake in it (at the very moment when his waterhole shows signs of transforming itself into a gas-station). The narrative is of his movement from external to (unsuccessful) internal mediator: from being a linchpin in the rudimentary institutionalisation of the frontier to a more ambivalent position thanks to Hildy.⁴⁶ Developing an understanding of the relationships in terms of the more complex categories taken from Bremond, it is clear that Cable moves from the amelioration of instrumental reason by the degradation of desire (his coldly calculated revenge story and Jason Robards' severe external performance) to the protection of instrumental reason by the frustration of desire (his waterhole has been a 'success' but his

relationship with Hildy has been frustrated). Joshua has been the spokesman of desire if not its full embodiment. Only Hildy suggests the possibility of a proper 'amelioration of desire' and the desynchronisation of two planes of reality which it entails.

What anchors this reading, in terms of both the film and the genre, is the association of Cable and Hildy with water: in the first instance as a commodity and in the second as symbolic of the flow of desire. The grinning Indian on the dollar bill marks the beginning of Hildy's subversion of the technical rationality informing Cable's enterprise. Where Cable initially makes a direct and utilitarian connection between water and money (the latter being the bait in his revenge plot), Hildy initiates a detour which associates the water with other, less territorialising, values, culminating in the scene at Cable Springs in which her presence changes the rhythms and organisation of the representational space. With her departure that space reverts to its function as a territory of realised will into which the objects of Cable's revenge will eventually come. The significance of this derives from the genre.

From the revisionary efforts (beginning in 1867) of the Geological and Geographical Survey of the Territories, the earliest large-scale application of technical rationality to the plains which had hitherto been widely considered an uninhabitable and threatening desert, arose a seminal statement of a theme which was to be central to the Western. Predicting more water in the plains due to climatic changes the survey's director Ferdinand V. Hayden affirmed 'the grand future that awaits the entire West' and thus, in Henry Nash Smith's interpretation, made a start on 'destroying the myth of the desert and legislating the myth of the garden'⁴⁷-- and indeed, concomitantly, on destroying the myth of the savage and legislating the myth, celebrated by Turner, of the self-regulated and industrious pioneer. But in the way of myth these antinomies lingered in parallel and others clustered around them to constitute the thematic flexibility necessary to an emergent and voracious popular culture--from dime novels through Porter's proto-documentary inspired by the exploits of the actual Wild Bunch and on to such baroque elaborations as the singing cowboy. The strenuous efforts which

went into consolidating the garden theme as the promise of an agrarian utopia had little or nothing to do with the American 'imagination' and everything to do with the conditions which Marx describes so succinctly: 'the enormous and continuous flood of humanity, driven year in, year out, onto the shores of America, leaves behind a stationary sediment in the East of the United States, since the wave of immigration from Europe throws men onto the labour-market there more rapidly than the wave of immigration to the West can wash them away'.⁴⁸ Hence the idea of the frontier as a safety valve for the class antagonisms predicted as early as 1836 ('then will the line of demarkation stand most palpably drawn between the rich and the poor, the capitalist and ^{the} laborer',⁴⁹). Henry Nash Smith reads a clear message in the prognostications of the time: 'The valve affords safety for the property of the rich against the potential violence of the poor, who are withheld from their vandal attack on the possessions of others by being enticed away to the West'.⁵⁰

The safety valve did not actually work that way--the 'sediment' could not be cleared so easily and the last quarter of the nineteenth century saw the beginnings of violent class warfare⁵¹--but the early prognosticators had underestimated the power that would be developed by what Takaki (after Weber) calls the 'iron cage' of 'centralized corporate lines of force'.⁵² However, the idea of the frontier did work; it found its proper domain within the developing culture and deployed its line of desert/garden 'ambivalence' there to ideological effect, appearing to offer options for the individual who would exert his sovereignty over the wilderness as a space in which an identity could be freely forged. In narrative terms the values of individualism survived the actual infrastructural 'iron cage'. The safety valve (sited in the West only insofar as that is where the California media community is) re-established itself on another level of the social formation.

Cable appears to choose the garden over the wilderness, relative respectability over savagery, putting down roots, using the water for civilized ends, but Hildy exposes the degraded

rationality of the project; she embodies a challenge to the ideology of blind domination caught up in the Western's thematic cluster-- domination of one's self and of nature--and threatens to crack the code of instrumental reason. Embodying finally another kind of space, a deterritorialised space (just as her body has gone beyond being a territory of man's realized will), Hildy has no consonant place in the film and goes elsewhere, returning at the end to find Cable only then willing, when it proves to be too late, to re-enter the flow of time and to leave the static space of Cable Springs.⁵³ In the typical landscape of an essentially timeless West, the hero's function, as the representative locus of dominance, is the gesture of 'a subject that has sought refuge', as Paul de Man proposes in a similar context, 'against the impact of time in a natural world to which, in truth, it bears no resemblance'⁵⁴ (and thus becomes recognisable as a problem with a history rooted in the analogism of the eighteenth century--'the divine Architect has designed the universe analogically'⁵⁵).

If instrumental reason is to be the final content (the ideology of form) of the first term which has appeared throughout this study in various guises, it is necessary to put the distinction between an 'inner' form and an 'outer' on an equal footing by identifying it, in certain key respects, with the distinction between a mass level and an institutional level. It is the maintenance of instrumental reason as an axis between these levels that allows, in the most general terms, for the disappearance of the individual's freedom before the sovereignty of the state which embodies the general will; as Marcuse has pointed out, the whole ('society') is in this respect equipped with the properties of the individual.⁵⁶ Insofar as instrumental reason is established as a defining feature of individualism, the institutionalisation of instrumental reason will follow the logic by which, as Poulantzas suggests, the sphere of the individual 'appears to have no other function but that of providing a reference point, which is also a vanishing point, for the omnipresence and omniscience of the political instance'.⁵⁷ It falls, therefore, to the ideology of individualism

to celebrate culturally the emergence of the self-reliant individual from the mass level and his successful self-definition against the constraints and/or within the disciplines of the institutional level as the 'outer' form (political existence in the State) by which the individual appears to attain social existence.

We have found this ideological effect to be caught up in a hall of mirrors which sees it also manifested in the tendency to locate, centripetally, a characterised 'inner' form to filmic material, whether by identifying a character as the thematic centre within an analogous mise-en-scene space or, ultimately, by focussing attention on the auteur within a thematically coherent 'structure'. The form and substance of expression are assimilated to the model of natura naturata as the object of an instrumental reason. The model of natura naturans insists that interiority does not go beyond the presence of the structure in its effects and, therefore, folds the form and substance of content back towards the subject and the signifier, away from the (essentially narrative) promise of an isolable 'human content' or 'truth'.

The fundamental problem with the 'inner' form/'outer' form model is that, taken to its limit, it sets up a limited anteriority presumed to be the mental 'structure' of an addressee and overlays on this 'deep' centre the formal structures of a communicative object through which a 'content' (in the sense of some kind of mental substance) is transferred onto the mental 'structure' of the addressee. The 'outer' form of the object is, therefore, separated out from the thematic structure (the form of content) which tends to be grasped centripetally in the sense that it is taken to refer to an individualized human 'reality'. The challenge to critical practice is to think the category of thematic structure in a non-individualized way: narratives, events, emphases, where they are conventionally seen to cohere around the centre of a character in the text or an auteur outside it, have to be read according to a different dynamic. A centrifugal interpretive movement will approach not a 'deep structure' which can be appropriated by a notion of essential mental 'structure' but a dispersed structure which finds anteriority effectively unlimited (the accumulation

of the already said, of deposits, of past signifieds now taken up as givens and required to function as signifiers at a more complex level of the system) and finds its 'content' in the ideology of form. In this study the latter has entailed the construction of a schema of textual space such that the organized control of 'mimesis', or imitative desire, can be articulated with the narrativisation of instrumental reason. The processive model of natura naturans, that is of constituting form in place of essential 'inner' and phenomenal 'outer', entails re-locating Intentionality in the text where it is structural in the proper sense (as distinct from supposed intentions derived from an anterior mental 'structure' and the experience which invests it): 'The structure of the chair is determined in all its components by the fact that it is destined to be sat on, but this structure in no way depends on the state of mind of the carpenter who is in the process of assembling its parts'.⁵⁸ We have suggested that what 'sits' in the text is desire, but the connotation of rest is perhaps misleading.

'Peckinpah' has indicated here a textual space particularly well designed and assembled, within the conventional limits, for the desire that is to use it, and the relationship of this assemblage to an anterior personality has been of no relevance at all. The Ballad of Cable Hogue takes its place, not in a weak transumptive chain in which 'Peckinpah' designates the succession of a new and distinctive personality to the same old throne of a continuous imaginative tradition, but in a strong transumptive chain (and here we are using Harold Bloom's terms without reaching quite the same hyperbolic conclusions) where, in genuinely Emersonian fashion, the reading of a text (whether the 'reading' of Hemingway and the others in The Ballad of Cable Hogue or our reading of the latter itself) does not rest comfortably in that text. Instead, as a 'bright casualty', it searches out the point where a substitutive operation is worked on the desire invested in the text and encounters, therefore, at the very least, the possibility of a reversal.

We shall return to the question of substitution. For the moment the various strands of the present chapter can be drawn together. A synchronic

structure is dramatised into a diachronic narrative: the axis of imitative desire connects the serial and institutional levels and is endlessly repeated by the Oedipal dramatisation, the narrative of which establishes the synchronic memory-picture. Transcoded as 'influence' the 'outer' form or system can either be taken on its own terms or it can be put into question. On its own terms it becomes the testing-ground for the individual (nature/hero, genre/auteur) with the latter always taking over the place of the 'inner' form and accepting or attempting to resist the constraints and/or disciplines of the system. Put into question, the synchronic memory-picture and its dramatisation (the son's initiation into the system of the Father) are found to depend on instrumental reason as the privileged first term of an oppositional structure and on the displacement of desire (taken here to be the contrary of instrumental reason) into a sexual grid. Influence then becomes a matter of the continuing tension and interplay between this grid and the desire which it holds in place--between, finally, text and audience. A strong reading will reconnect with this desire as the true pneuma which promises

that the imitable memory-picture and its dramatisation are ultimately revisable, 'corrigible' in properly Emersonian fashion.

That we have found the Western in the seventies to be inherently resistant to the kind of ideological closure so evident in the police film, suggests that a genre can develop to the point where it systematically causes the idea of origin to get off course, to be deflected by a repetition which pursues difference where originality pursues sameness (see Chapter 1). The imaginary exchange between the system and the extrasystematic (the individualized, originating centre) is blocked by the very density of the generic system and with it, perhaps, the mystifying exchange between the institutional level and the mass level through an individualized mediator who occludes the fact that the mass or serial level is the vanishing point for the person and, therefore, the reference point for the omnipresence of the system, as Poulantzas suggests. The (uneven) development of this deflectional density (with the War film, for example, lagging far behind the Western) may go some way towards explaining what happened to Hollywood films in the late-forties and fifties

and why cinephiles are so drawn to that period. The police film in the seventies could, therefore, be read as a belated attempt to recover the Detective film from a density, which incarnated desire better than in any other genre, in the film noir of that period, and which threatened to overflow the grid. (Similarly, the attempt in the seventies to start over again with new genres-- the 'caper', 'disaster' and 'sword and sorcery' cycles for example--may be indirect evidence that some of the Hollywood genres proper had become less manageable.)

10.4 'Resolution'

It is necessary to put this analysis into more concrete terms. In La Porte and Abrams' extremely suggestive account of California as a testing-ground for American 'postindustrialism' there is sufficient information and analysis to form a definite hypothesis on the kind of subtext which this study has approached in certain aspects of its cinematic object;⁵⁹ particularly so in the light of the concentration in California of the production of TV and cinema films (and records). Apart from the generalisations--such as the impact of 'California's chiaroscuro: its bright lights and dark deeds'⁶⁰--Tunstall and Walker's complementary study traces in detail the development there of youth culture (the general postwar baby boom combined with the state's high proportion of immigrant families), the subordination of 'hard' news to the odd and trivial, the 'zany', the 'screwball' (time zone differences making California 'late' as a source of serious up-to-the-minute news) and, most importantly, the steady development of power in the Beverly Hills media community since its establishment on the basis of cheap land and (non-union) labour; power which is

a crucial component of the end-weighted New York-California axis and dialogue of the culture industry. Taking Tunstall and Walker's case as argued--'that American media can be better understood by examining their California component' because of 'the circumstances of California history and the location of the entertainment-producing industries'⁶¹--we will be able to draw on La Porte and Abrams' study of Californian patterns of 'postindustria' in confidence that the subtextual conditioning of our textual object will consequently be open to interpretation from this perspective.

With the giant conglomerates buying up the studios and the effects of the decentralisation of urban communities still being felt, the seventies saw the success of young film-makers attuned to residential suburbia as a 'change of mind' (a complex of values relatively independent of the actual social reality of specific suburbs⁶²) and intuitively sensitive, it would seem, to the kind of cinema which would attract an audience from among those for whom television was now fully integrated into the range of home-based 'leisure' activities.⁶³ And the decade saw too the

institutionalization of this acumen at the conglomerate level with huge sums spent on advertising these film-makers and their work in order to manufacture and package the 'event' (with massive spin-offs into publishing, the record industry, toys, etc.) which would be an occasional element in the established pattern of 'leisure': 'Blue-collar workers thought playing with children, seeing friends, and visiting family were all activities infinitely more significant than going out to a movie' (and sixty percent of them could not, in 1970, realistically afford to take the family to the cinema more than once in three months in any case).⁶⁴ Having produced and packaged sufficient 'events'--particularly in, or modelled on, the Spielberg-Lucas camp--to establish an attractive new-cinematic gigantism based on 'spectacle' and on material which appeared to transcend the staple action-adventure series or TV-movie, the strategy is clearly to infiltrate home-based 'leisure' on the strength of this 'spectacle' (video, cable, satellite) even if the bulk of material on offer will be barely distinguishable from the already fundamentally cinematic films

and film-series on television. In short, the cinema 'event' of the seventies has, in the last analysis, been a strategy for expanding the cinematic within home-based 'leisure'. It has apparently aimed to convince the ephemeral consumer that broadcast film (whether made for TV or not), including the film-series with its cinematic mode of address, narrative structure and characterisation, is in itself insufficient and that an injection of the new 'spectacle' is needed. It will inevitably be more of the same as the 'spectacle' is largely a product of the publicity machine⁶⁵ (which is now the cinematic machine par excellence, engaging a full investment of imitative desire with anticipatory pleasure cut free from the specific film) and the actual differences distinguishing say E.T. have already been fully absorbed by television (with achievement of the high-definition 'presence' of the theatrical image only a matter of time).

The obvious interpenetration of monolithic conceptions of cinema, television, leisure and the homogenous (classless) audience (an interpenetration which is itself characteristic of

'postindustria' and of the software-saturation of late consumer capitalism) exhibits the consolidation of the two distinct levels identified by La Porte and Abrams as the institutional level and the mass level. We shall suggest that an increasing public perception of the success of the entertainment conglomerates has an ideological function in relation to the widespread perception of an increasing failure in other sectors of the institutional level. Concomitantly this perception of success has a strategic importance in counteracting the ever-present potential within urban decentralisation for a community-based, group appropriation of 'leisure' in such a (less consumption-oriented) way as to threaten the culture industry's penetration and its corresponding reinforcement of serial relations and the omnipresence of the State. This was particularly so in the seventies as only then did the sheer scale of the post-individualistic nature of late capitalism's 'suprapersonal' apparatus begin to emerge into consciousness (through, for example, crises like Watergate in conventional individuated models of sovereignty and a sense of powerlessness in the face of multinational processes occasioned by such phenomena as the oil scares).

The conceptual contents of the institutional and mass levels have to be grasped in their mutually determinative interaction; as part of the 'map' of the macro-space of everyday life the overarching institutional level bears the individual's perception of such crises and of his own powerlessness; and the mass level reflects in turn a socio-economic organisation which is interested in seeing people in such terms. The resolution of the various disjunctions between the two levels should fall, as John Kenneth Galbraith implies, to an ideology of the technostructure; of, that is, the institutionalised group:

In the past, leadership in business organisation was identified with the entrepreneur--the individual who united ownership or control of capital with capacity for organizing the other factors of production and, in most contexts, with a further capacity for innovation. With the rise of the modern corporation, the emergence of the organization required by modern technology and planning and the divorce of the owner of the capital from control of the enterprise, the entrepreneur no longer exists as an individual person in the mature industrial enterprise . . .

The technostructure...lodges the power of decision with groups. And these involve the participation of a large number of individuals of widely varying rank and position. Thus, a large number of people have access, or the illusion of access, to power. . . .

The relationship between society at large and an organisation must be consistent with the relation of the organisation to the individual. There must be consistency in the goals of the society, the organisation and the individual. And there must be consistency in the motives which induce organisations and individuals to pursue these goals.⁶⁶

Instrumental reason is, we have suggested, the form of such consistency and the 'illusion of access' is the space within which a distinctive ideology of the institutionalised group or techno-structure may be held to operate.

Focussing, within the first interpretive horizon, on one of the Western's basic oppositions --inside/outside 'society'--and its coding, Wright identifies what begins to look like such an ideology at work within the genre which had for so long enshrined the older, individualistic ideology:

As in the classical plot, the heroes are acknowledged gunfighters, but now they are also acknowledged professionals; they make their living as gunfighters. There is always more than one; there is always a group of heroes. This multiplication of heroes, together with their professional status, is probably the most significant change in the hero's code for the inside/outside distinction.⁶⁷

By this account the group of professionals is, to all intents and purposes, a technostructure; the genre allowing it to appear to operate more independently of institutionalised anchorage than is the case in contemporary organizations (just as the 'classical' hero could defend social values from 'outside' and therefore function to legitimate them for those 'inside'--Turner's frontier individualism translated into the entrepreneurial ideology). This self-validating emphasis on groups and techniques (which Wright sees exaggeratedly at work, for example, in the Watergate affair with its emphasis on team-loyalty at the expense of public trust) carries over into what Wright identifies as the other basic oppositions of the Western: particularly good/bad and strong/weak. (In Washington: Behind Closed Doors Martin simply shifts 'good' and 'strong' onto another group, the CIA, with only minor ambivalences which the text relegates to a past now outgrown.) In the Western's latest phase, as Wright sees it, 'good' and 'bad' are now less closely tied to social values; hence the celebration of the Hawksian idea of 'good' in the seventies when what matters is skill and

technical accomplishment--Marlowe's timeless assessment of Vivien in The Big Sleep is emblematic: 'You looked good, awful good. I didn't think they made them like that anymore.' While the films directed by Hawks, including the Western 'professional plot' trilogy beginning with Rio Bravo, recover this technical sense of 'good' for the explicit legitimation of social values, its celebration in The Wild Bunch or the 'street-Western' Assault on Precinct 13 is in almost entirely technocratic terms. Similarly 'strength' and 'weakness' are largely re-coded in terms of technical power and skill rather than values and principles; such skill is the prerequisite for membership of the group--i.e. of the technostructure--which guarantees (the illusion of) power.

The problem with this line of argument is that, despite such apparent 'ideology-of-the-technostructure' vehicles as The Wild Bunch, Assault on Precinct 13, The Warriors, perhaps The Godfather, its development (inside or outside the Western) has not been as emphatic or uncontradictory as Wright suggests (writing in 1975, however, when evidence was still sparse):

the Wild Bunch, as we found in Chapter 1, die at the very moment when they fully realise their group identity and the notable Westerns that follow Wright's mid-decade assessment include The Missouri Breaks, Heaven's Gate and Comes a Horseman which collectively make the professional plot look like another 'transition theme' while recovering Little Big Man ('mostly just embarrassing to my categories' says Wright), Jeremiah Johnson, The Ballad of Cable Hogue and Pat Garrett and Billy the Kid for a much more complex Western of the seventies than the professional plot would have allowed.⁶⁸

Outside the Western a similar difficulty arises. In Jaws,⁶⁹ for example, which appears to opt for the skilled group as its narrative solution the group totally botches things and it falls to the lone sheriff to repeat the explosive climax of Rio Bravo. Indeed the overall effect of the police film as explored in Part III is to re-work a simple ideology of the technostructure in precisely the place where we might have expected to find it triumphantly established: the closest this sub-genre of the Detective film comes to a straightforward adoption

of a kind of professional plot is in the Police Story series and there, as we have seen, it encounters fundamental problems which require elaborate resolution. Elsewhere the emphasis on a technostructure is displaced, either onto the conventional, individualistic figure of authority with institutional support (Ironside, Kojak) or, increasingly, reconstructed as a threat to the individualism of the isolated, troubled 'street cop' (Baretta, Serpico, A Question of Honor). This ambiguity is tightly controlled and appears to allow for a range of interpretations without jeopardising its ideological function.

It is, for example, interesting to juxtapose in this context two perspectives on Jaws. The first is given by the Secretary of the British Board of Film Censors:

On balance, I think that what was reassuring about Jaws was not its realism but the fact that it was actually a very healthy framework. The society was very closely observed, the central characters were very heroic, and it had an epic quality of Man versus Beast, one of the great myths of childhood. It was a very moral film. The sheriff was like Gary Cooper in High Noon, fighting the local corruption . . . 70

The second, from Jane Caputi, is typical of a trend in feminist film criticism:

Jaws is by no means a merely scarey story, good 'clean horror', as one reviewer enthused. Rather, it is the ritual retelling of an essential patriarchal myth--male vanquishment of the female symbolised as a sea monster, dragon, serpent, vampire, etc.--administering a necessary fix to a society hooked on and by male control.⁷¹

The approach developed in this study, however, insists that it is other than a matter of deciding whether a film such as Jaws is or is not 'healthy' and 'clean'; it is necessary to grasp the structure which embraces such opposites and this is true, not only of the police film studied in Part III, but of the other spectacularly 'healthy' films so characteristic of the decade and its legacy (the Star Wars trilogy, Close Encounters, Raiders of the Lost Ark, E.T.).⁷² Whatever one's sympathies with the political perspective which rejects these films as patriarchal myths, it is insufficient simply to 'decode' them in order to reveal a fear of 'woman' and an uncontradictory manifestation of patriarchal authority (such as the 'Force' in Star Wars). So in Jaws the shark can be read

as both a symbol of 'woman' as problem and threat and of the institutionalised corruption which endangers the people (the town fathers care more about the tourist trade than the risk to lives); just as in Hustle the Albino whale is both the problem thrown up by the sea (the woman as transgressor, as threat to the father's authority --the body on the beach and the prostitute) and a symbol of corrupt power (Leo the Kingfish).⁷³ We have found that this is possible because instead of a single 'patriarchal' position these films deploy, within a complex actantial structure, an internal mediator who is isolated and suspicious of those who wield overt power.* The character who fills this position tends not to be in control of the situation and is often demoralized: the boy in E.T., the adolescent hero in Star Wars, Roy Neary as Close Encounters' Peter Pan, the sheriff in Jaws trying to play Gary Cooper, to work out how a hero should look... . When he is successful it often seems to be through a knowing invocation of the impossibly successful hero of the thirties' adventure serials (Superman, Raiders of the Lost Ark).

* the 'disturbance' which he counters can therefore be split between the other functions; see above, p.659

Things are not as simple as Caputi suggests. The patriarchal town elders in Jaws are shown to be corrupt and even Quint, despite his Hemingway-esque mystique, is a shadow of what we suppose to have been his former self and can do nothing. Neary in Close Encounters abandons his messy attempts to play the father and waits for 'a deity straight out of Disney animation, all sweetness and light',⁷⁴ (and whose numinousness is again simultaneously patriarchal, in its strident high-tech power and booming 'voice', and female--the 'Mothership'). Luke in Star Wars is effectively an orphan and the family in E.T. is fatherless. We could continue to multiply the signs of trouble which undermine anything that looks like a simple 'patriarchal myth' (the strong father-figures in TV's Dallas and Knots Landing both die violently, the father eventually leaves even The Waltons...⁷⁵) but the pattern should be already clear. As the work of the preceding Part indicated, it is necessary to grasp the more complex interaction of textual and institutional aspects; of the familial structure and the substructural conditioning which erects it as a decoy. As the final step towards

this, we shall re-cast the terms of the interaction according to La Porte and Abrams' study.

That the textual aspects of popular culture should exhibit a particular sensitivity to the patterns of 'postindustria' derives from several factors. 'Leisure' is itself a phenomenon of postindustrial change and so the popular culture fostered by the 'leisure' industry is already implicated in the effects of a changing mode of production and, for example, the increasing emphasis on technical rationality as a factor of production will have a 'natural' opportunity to filter into the textual domain. That California is something of a proving ground for postindustrialism while also being, appropriately, a powerful centre for the culture industry, makes even more likely the textual assimilation of 'postindustria' as a picture of a future social formation projected from the forefront of actual change.

The widespread perception of a crisis-prone system in the seventies has led into a perhaps not unrelated burst of renewed consumption, but now pre-eminently of 'leisure' software over the traditional hardware of the stable industrial

phase. Among the most salable of contemporary hardware is the machinery for this proliferation of the 'aesthetic'. Its widespread availability by the end of the decade, with the promise of more and better, indicates the extent to which the culture industry has taken upon itself the role of representing the distinctive postindustrial feature of blossoming technological possibility. Galbraith's technostructure could now be expected to find itself recast as a knowledge élite, mediating between the institutional level of production complexes and a mass level characterised by an increased expectation to consume the fruits of technological possibility in the relatively new category of 'leisure'.

The serialising effect of the screen on the mass level is compounded by these changes: the proliferation of screens is increasingly supported by, for instance, symbiotic relationships among the media (e.g. mass-circulation newspapers reporting media 'news', or the video boom in rock music), more sources to feed onto the screen (tape, disc, cable, computer, satellite) and by the specific development of the serialising effect to an extreme (e.g. 'personal' receivers

and playback equipment). It becomes, therefore, a matter of pressing concern that the textual features peculiar to this context should receive critical attention.

Returning to our basic interpretive coordinates, the desire for deserialisation and the sexual grid by which this desire is managed, it transpires that the textual features isolated in this study find their places in relation to a pattern of 'postindustria' which La Porte and Abrams identify as 'unstable'.⁷⁶ Where the ideology of the technostructure would have reflected a stable pattern of reliance on a knowledge élite--the professional experts in technical rationality--in the unstable pattern (which has presumably overtaken Wright's 'professional plot') there is an increasing perception of social, economic and management failure. ('We are suggesting that events and actual conditions have outrun the capacities of experts, both public and private, to understand them well enough to plan reasonably effectively.'⁷⁷) In their California case-study La Porte and Abrams construct this 'map' of the macro-space of 'unstable post-industria'.

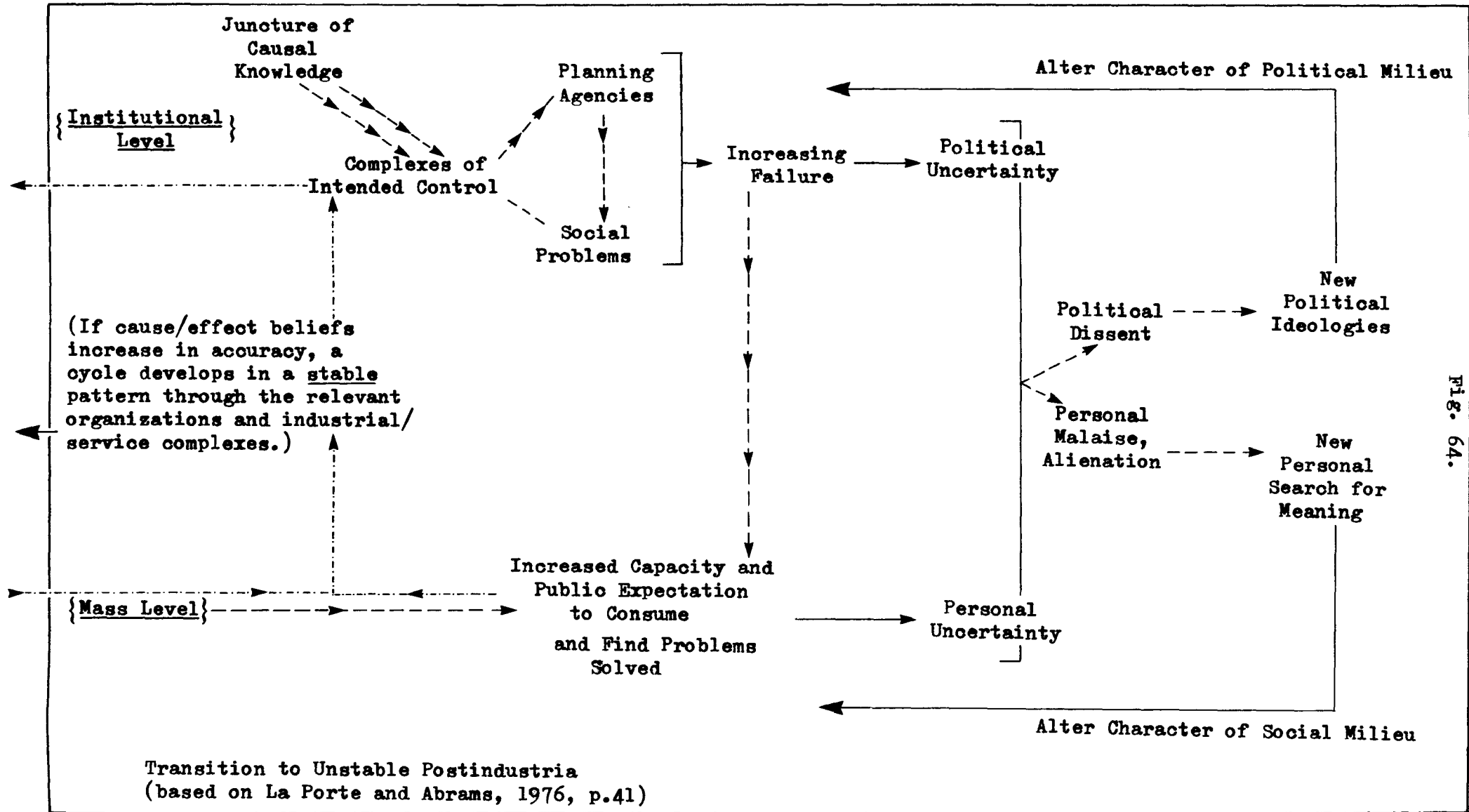

The principal features of La Porte and Abrams' 'map' correspond to the synchronic memory-picture proposed in this study:

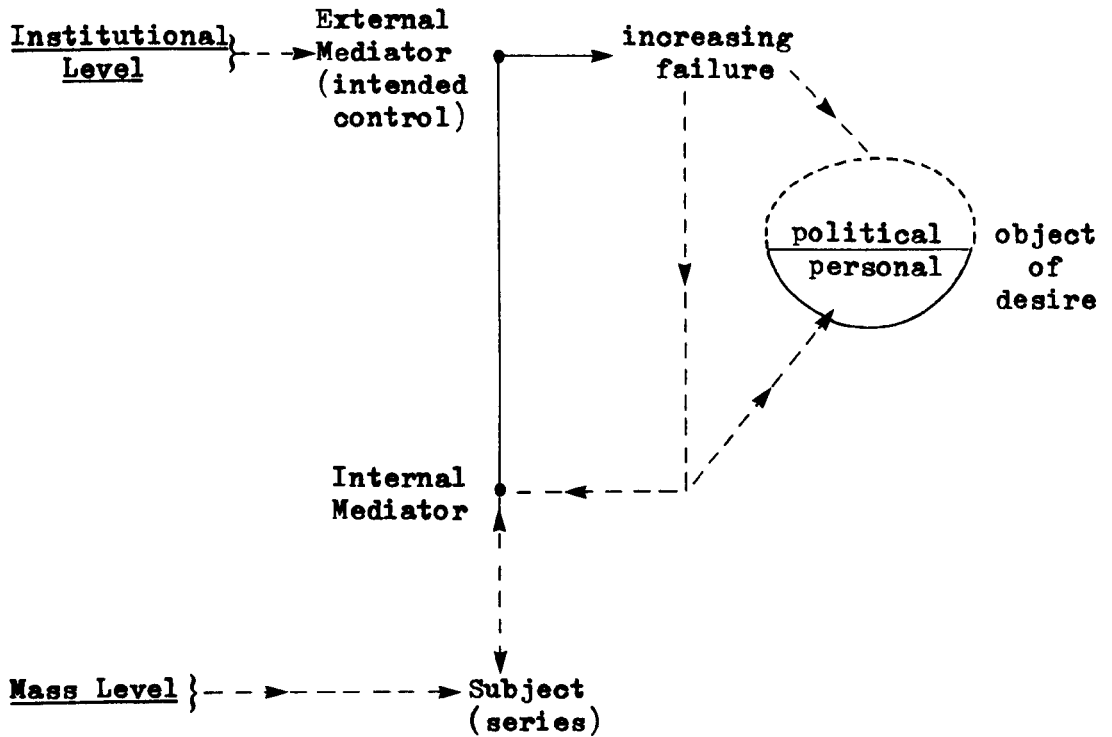

Fig. 65.

The textual 'resolution' ('search for meaning') opts for the 'personal' ('naturally' centred on the woman) rather than the 'political' and converts the entire pattern into an Oedipal grid, establishing an internal mediator who holds in place the 'failing' institutional position. What

is important is not to accept the Oedipalisation and fight a feminist campaign, as this would leave the structure untouched, but to recognise that what we see repeated in film after film is an anticipation of the return of an external mediator which can only be, in this context, the figuration of an eventual restabilisation achieved, not by progressive political innovation, but by, for example, a powerful intrusion of the State. As Szelenyi's discussion of an intrusive State mode of production indirectly suggests, the figure of 'external mediator' may anticipate in fact the outcome of a struggle between the State and multinational capital.⁷⁸ Whatever the victor looks like at this level, it seems clear that the serial level is already being well prepared for an eventual enforced restabilisation of this kind.

It has also been suggested, however, (and here the interpretive movement makes its regressive fold) that the price paid for this 'resolution' is the awakening of the series' protopolitical desire. That this desire is managed by a repeated displacement from the political onto the Oedipal does not alter the fact that the desire is there every time and that there

will be as a result a 'steady state' of desire (an unconscious, or pensée sauvage) throughout the popular culture (assuming that such a mechanism of displacement is typical). The spatial text which displays these terms, relations and structural dimensions has been the principal 'thesis' of the present study:

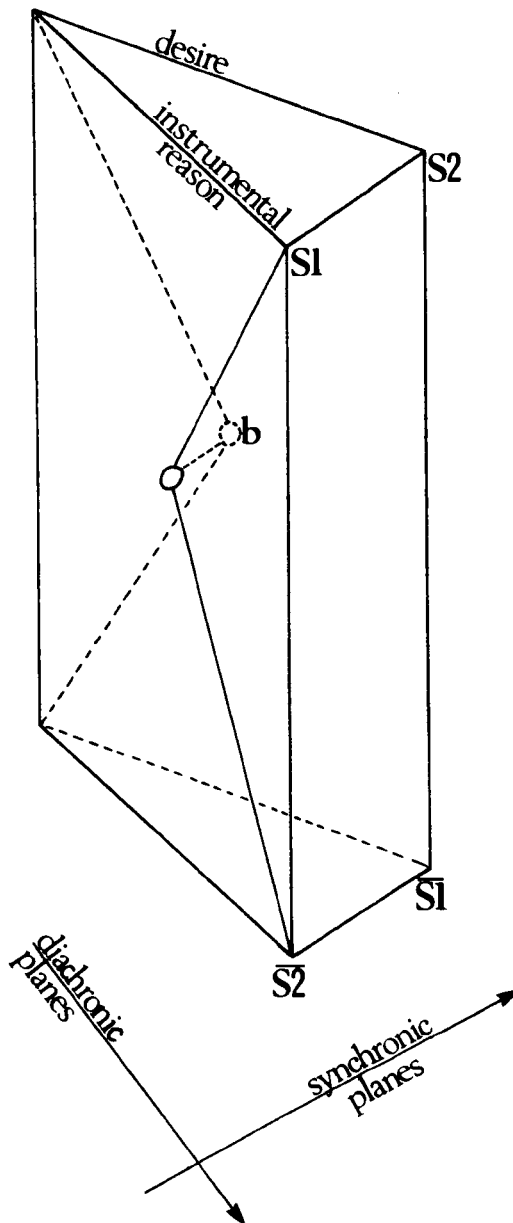

Fig. 66.

Taking The Ballad of Cable Hogue as the final example, (b) is filled by Hildy. Through her the invested desire is shifted (ideological code switching of a metonymic kind according to Eco's theory⁷⁹) off its own plane onto the plane of instrumental reason in order to establish Cable's axis of mediation (S1-S $\bar{2}$) in relation to which Hildy returns as S2 (with Joshua as $\bar{S1}$). This example is helpful in suggesting the potential for subversion always already within the structure. Joshua insinuates himself into the term 'desire' and draws off the sexual coding from Hildy (carnal pleasure being apparently his sole object in life) who now all too clearly embodies desire as the contrary of instrumental reason and has to be removed; hence the failure here of the structure of oppositions to provide the Oedipal 'woman'. But Hildy finally returns and Cable's internal mediation is ultimately unsuccessful.

This dialogism, between the dominant plane of instrumental reason and the plane of desire, draws together the various dialogical features encountered in this study. Stripped of 'content' it is the basically paranoid structure identified

by Adorno and Horkheimer and appears, as Jacqueline Rose suggests, in cinematic terms in the suturing shot/reverse shot pattern: there is an activation of aggression because of 'the fact that the camera must identify with both terms of the opposition, and in the place of one of them cannot be assimilated to a subjectivity'.⁸⁰ Where this aggression conventionally goes is a defining feature of each popular genre: the enemy in the War film, the monster/alien in the Horror/Science-fiction film, the diegetic audience in the Musical, the criminal in the Detective film, the Indian in the Western.* If these repositories become unstable--as with the American Indian--the aggressivity leaks across the film (as we found in The Wild Bunch) and the genre begins to take on a density through which desire will pass less easily into the structure prepared for it. So in Cross of Iron when the woman is discovered bathing in the water barrel a castration follows: she is the enemy. As a Western, The Ballad of Cable Hogue can be different.

* providing one answer, at least, to the question posed on p.1 (Volume 1)

The question of the embodiment of the structure has also raised the possibilities that performance may support or undermine the axis of mediation. The celebration of a stable and invisible 'inner' form (instrumental reason as the form of will, character, originality, individualism . . .) by the erection of a hard-shelled 'outer' form as its body, does not express the essence of the institutional level; rather it evokes, as we have seen in Part III, an archaic coding of desire--on the body of the sovereign individual, the benevolent despot as external mediator--to support the sovereignty of the State or of transnational capital as the ultimate contemporary realities of the institutional level. The first indication we had of the flexibility of this procedure came in the reading of Washington: Behind Closed Doors where performance was found to constitute a system which placed characters in such a way as to contain various disruptions to the stable structure of power relations. 'Ritualism', or the body imagery of an estrangement from affective relations, was established there as the key term in the system.

Takaki provides the apposite observation that 'Americans seeking to build within themselves republican "iron cages" became imprisoned in the corporate "iron cage" of the modern economic cosmos': this marks 'the transformation of American society from self-regulated "republican machines" to corporate-regulated men'.⁸¹ There is here a rich insight into the transformation of the US from the agrarian-commercial nation to the exemplary institutionalised social formation of controlled consumption based on imitative desire. The model of the republican 'iron cage' in which the original self was to be productively confined is provided for Takaki by Benjamin Rush, signatory to the Declaration of Independence, educator, philosopher, Father of American Psychiatry and ideologist of the post-Revolutionary nation state without a sovereign: 'Because the source of authority was now located within the individual, men must be converted into what Rush called "republican machines". In "An Address to the Ministers of the Gospel of Every Denomination in the United States, upon subjects interesting to morals", delivered in 1788, Rush described how

people should conduct their lives in a republican society. Their paramount concern should be self-restraint and control over the passions and the demands of the instinctual life'.⁸² (And for those who could not or would not curb the instinctual life, Rush invented a 'tranquilizer'.)* What we have termed the external performance, the impenetrable shell supposed to contain a stable and essential centre, is an appropriation of Rush's 'republican machine', advertising an 'iron cage' for the seventies.

A steady increase in state expenditures having reached crisis point, capital's counter-offensive consequently burgeoned in the seventies. But the explicit theme of the 'small' State, widely propounded as a result of this alteration in the character of the capitalist political milieu, does not find a direct echo in the structural simulacrum of the area of popular culture probed here. Urban decline, frequently the context for police fiction on screen in this period, and the city as a crisis-ridden mise-en-scene (the subtext too of such films as The Wild Bunch and The Ballad of Cable Hogue which, as we have seen, figure and fracture ideologies of rationality deeply implicated in contemporary strategies of power) increasingly picture a social milieu incompatible with the 'official' projection.

* see the frontispiece to Vol.I

With the 'political' consistently displaced into the 'personal' (itself simplified as the 'sexual'), the Oedipalised analogon anticipates something which (behind the 'disguise' of the return of the absent Father) looks very much like an increase in state interventionism. If what is anticipated is some kind of state mode of production, then the temptation to read popular cultural texts as simply 'fascist', 'progressive', or whatever (along the right-left axis) is now drastically misleading: the ideological colouration of such a social formation is not likely to take over intact the clean lines of the old dimensions of contradiction and it is feasible to read even the most rigidly 'new fascist' cultural phenomena of the seventies and early eighties, such as the 'Dirty Harry' cycle, as giving textual form to a more complex set of terms which articulate the mass level (the audience) and the institutional level (the State and the transnational capital with which it increasingly has to deal): at their most stark, the series and the 'huge abstract machine that overcodes the monetary, industrial and technological flux'.⁸³

So it is that in Sudden Impact⁸⁴ the American police film reaches simultaneously its most impatiently and noxiously 'fascist' image as a numinous Harry Callahan rises vengefully from the sea and, paradoxically,

one of its most striking demands for a better way than this of doing things. The double-bind habitually constructed for 'woman' here begins to unravel under stress to reveal its implication in a broader pattern: 'woman' is the catatonic shell, silenced, lacking, held in place as an essentiality (borrowed from Bronk)^{*} on which the story turns; also the principal object in the scopic field of male desire, but she 'splits' and, in the same figure, is both hunted and hunter, the 'deviant' and the heroine as internal mediator. This 'splitting' achieved in one figure forces the real double-bind: whether Harry, finally, should hand her over to the Law or let her go. Both options are 'wrong' in terms of the film's own logic. The 'less-wrong' (letting her go) is the recognisably 'fascist' way (advocating an heroic, 'purifying' élite) and the film takes it, but in doing so fails to 'punish' the literally emasculating woman who embodies a ferocious assault on phallographic iconography. The film's extremism is a matter of pushing the protopolitical desire of the series so far into the semiotic categories developed by the 'Dirty Harry' cycle as a whole that they shatter (like the mirrors in the film); there is finally no convincing Law of the

* see p.356

Father (only an ordinary lawman trying to protect his catatonic son, the woman's final 'victim', coming full circle).

Taking the weariness of Sudden Impact's 'fascism' as a cue for an oppositional reading, the possibility is there of translating the fractured phallogentric iconography back into 'political' terms (politicising the object, hitherto 'personal', 'sexual') as a desire to escape both the powerlessness of seriality and the massive interventionist apparatus of the modern institutional level (between which the film can find only an extremism): the desire which, within the pre-formations of a possibly emergent state mode of production, will be vital to ensure the continuance of the right to desire and perhaps ultimately to refuse the proffered lines of flight which organise a pervasive but debased and imitative desire. 'Lines of flight turn out badly not because they are imaginary, but precisely because they are real and move within reality.'⁸⁵

Sudden Impact's relentless fabula of revenge reduces its characters from potentially classed and gendered people (read 'naturally' by the audience) to actantial functions, not purposely to invite, so to speak, a 'structural' reading, but because the

'extremism' of the cycle's realisation of instrumental reason, in the iron-clad 'invention of secrecy' which is Harry, intensifies also the tabooed desire and so a compromise between instrumental reason and desire is more difficult to achieve. Adorno gives us a precise formulation of what a text like Sudden Impact, about which there is absolutely nothing 'progressive', nevertheless achieves: attacking Veblen's Theory of the Leisure Class, Adorno suggests that those features of mass cultural forms which might seem to be only '"invidious", revealing a bad will, do not only reproduce injustice; they also contain, in distorted form, the appeal to justice'.⁸⁶

It is, finally, the commerce and compromise between desire and instrumental reason which overdetermines the impression of representation and the passion for the cinematic: the somacentric pleasures of the cinematic (which, uncolonised, are the cinematic minus its institutionalised regulations) always begin to invest in the plane of desire at the expense of the plane of instrumental reason, but respectability takes over--there is the metonymic code-switch, the passage, the displacement, the blockage and re-direction by which the investment finds its interest in the promise of a stabilizing

fabula, whether the first story ('what was it about?') or the critically erected layers. (Hildy tells her 'story' when she returns to Cable but we hardly believe her; it's the alibi which allows her to return and, if screened, where and what she has been would have to bear the signature 'Jost' or 'Godard' or, at the very least, 'Scorsese'.)

What is left in the interstices of the story, in the eyes of its cyclones, is the body, the site of a communion which has always threatened to interrupt stories (and which 'occupied so much space (and so many feet) in the film, that less and less room was left for the story' until 'only the details were interesting'⁸⁷ and cinephilia bloomed). Bodies, performances, still do this, constituting an appeal, an entreaty in the midst of the dominant cinematic institution, on behalf of the passion for cinema.

That performance can re-connect itself, and the audience, with non-imitative desire, even within a structure of fundamentally imitative mediation, indicates the potential for a properly Emersonian overflowing of the level of the 'steady state' maintained in the system. Performance which breaks through the given boundaries and establishes itself as a structural 'interiority' which is not put in its separate, essential, 'inner', original place by the

hard shell of 'outer' form but flows through the whole system, promises that (as in bricolage) a revolution of the object is possible. In addition to the instances already encountered we could consider, to name a few, the eponymous protagonist in Serpico (Al Pacino), Nick in The Deer Hunter and Nate in Heaven's Gate (Christopher Walken), Danny in Prince of the City (Treat Williams), Mo in Cutter and Bone (Lisa Eichhorn)...or so many of the performances in films directed by Scorsese. But this work has been concerned with identifying the strategies of the countervailing police operation. Rather than celebrating the vital moments when desire overflows its bounds, this practice has taken their example and folded itself back through the object of desire to re-connect with the grounded accomplishment of subjectivity as the basis of a collective dynamics, rather than following the discourses of the Father and of knowledge towards some finished and privileged truth drawn up from, or installed in, the object. This return, the beginning of a helix (with the 'effects', as considered in Chapter 5, always running counter to the 'direction' of the discourse) depends on a discourse of grounds:

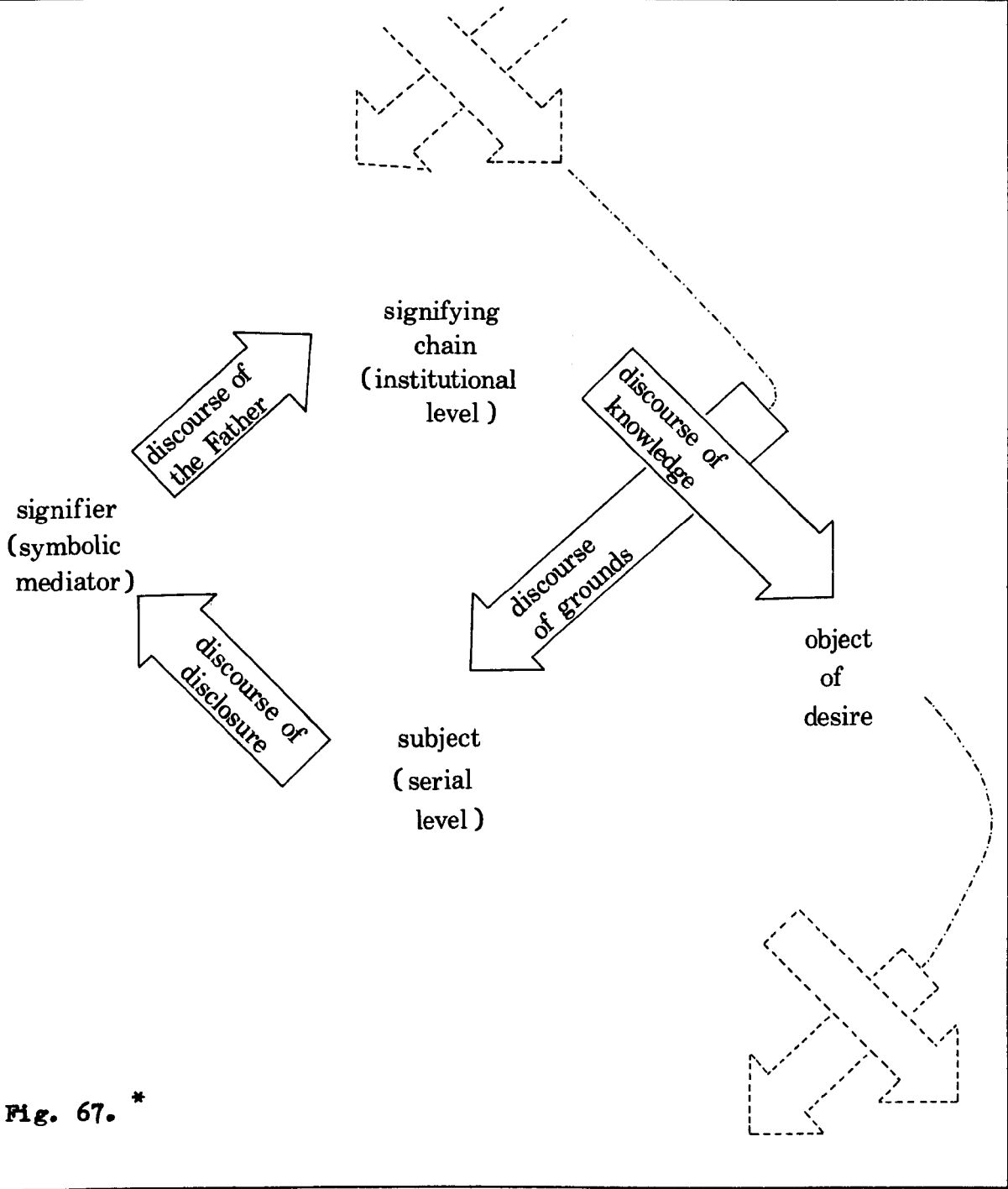

Fig. 67. *

* the upper and lower stages of each loop here are levels of 'knowledge' and 'non-knowledge' respectively, see pp.510-11

NOTES &
REFERENCES

Only sufficient information is given in references to enable the cited work to be identified in the Bibliography, section one (pp.758-71).

Credits:

d -director. sc -writer. p -producer.

exec.p -executive producer.

l.p -leading player(s).

UA -United Artists.

TCF -20th Century-Fox.

(Other production credits are given in full.)

Chapter 4

Investigative structure and the spectator

1. John Holloway, Narrative and Structure : exploratory essays, p.4.
2. 1952, Universal, d--D.Siegel, 1.p--A.Murphy (The Silver Kid)
3. Per Un Pugno Di Dollari (A Fistful of Dollars), 1964; Per Qualche Dollari In Piu (For a Few Dollars More), 1965; Il Buono, Il Brutto, Il Cattivo (The Good, The Bad, and the Ugly), 1966; sc--S.Leone and others, d--S.Leone, 1.p--Clint Eastwood (The Stranger/Joe/The Man With No Name).
4. 1975, Paramount, sc--S.Shagan, p/d--R.Aldrich, 1.p--Burt Reynolds (Gaines), Catherine Deneuve (Nicole), Ben Johnson (Marty), Eddie Albert (Leo Sellers).
5. Adapted from Holloway, p.8.
6. *ibid.*, p.12.
7. *ibid.*, p.10.
8. *ibid.*, p. 9.
9. See Richard Schickel, 'Good Ole Burt; Cool-Eyed Clint', pp.42-48.
10. Deneuve was familiar at the time on the strength of, at least, The Umbrellas of Cherbourg, 1964; Repulsion, 1965; The April Fools, 1969; Mayerling, 1969; while the rest of her substantial European career, though perhaps less available to American audiences, certainly contributed to her reputation as, in the words of David Thomson, 'perhaps the greatest cool blonde, forever hinting at intimations of depravity', (Biographical Dict., p.133).
11. Louis Althusser, Lenin and Philosophy and other essays, pp.153-154.
12. *ibid.*, pp.154-155.
13. *ibid.*, p.162.
14. Louis Althusser, For Marx, p.142.
15. *ibid.*, p.147.
16. *ibid.*, p.148.

17. Louis Althusser, For Marx, p.149.
18. *ibid.*, p.149.
19. *ibid.*, p.150.
20. Jean-Paul Sartre, Psychology of Imagination, p.220, translation modified.
21. *ibid.*, p.220.
22. Fredric Jameson, 'Dog Day Afternoon as a Political Film', pp.90-91.
23. *ibid.*, p.90.
24. Jean-Paul Sartre, Critique of Dialectical Reason, pp.256-69.
25. *ibid.*, p.271.
26. *ibid.*, p.270.
27. G.B. 1975, TCF, sc--J.Sharman, R.O'Brien (based on the stage musical by O'Brien), d--J.Sharman, l.p--T.Curry (Frank N. Furter), S.Sarandon (Janet)
28. 1980, MGM, sc--C.Gore, d--A.Parker, l.p--I.Cara (Coco), L.Curreri (Bruno), L.Dean (Lisa).
29. For instance, video machines are usually set up at home with a direct connection to the external aerial so that when a pre-recorded tape is stopped the broadcast flow immediately takes its place.
30. 1973, Warner, p--R.Daley, sc--J.Milius, M.Cimino, d--T.Post, l.p--Eastwood (Callahan), Mitchell Ryan (Charlie)
31. A personal note: one of the clearest experiences of the complex nature of an audience came to me when a screening in a crowded cinema in Northern Ireland was interrupted by the discovery of an incendiary device. The sheer otherness and threat to one's own safety offered by every person in the scarce space of the cinema came as a sudden shock after the cosy collective absorption of everyone in the film of only a moment before. Unlike an accidental fire this was the realisation of an actual threat from others within the same community.
32. Groupe en fusion, fused group; see Critique, p.357 and *passim*.
33. Critique, p.132.
34. *ibid.*, pp.351-63.
35. When the Lights Go Down, p.255.
36. Critique, p.719.

Chapter 5

Before our eyes?

1. When the Lights Go Down, p.253.
2. Richard Irving, whose first major success was Ransom For a Dead Man, 1971 (see ch.3), is a prolific executive producer/producer/director, a not uncommon conflation of roles in American TV: The Name of the Game, 1968-72, Universal/NBC, d--include Irving, Ben Gazzara, S.Rosenberg, M.Chomsky; The Six Million Dollar Man, 1973-78, Universal/ABC, d--include Irving, R.Donner, G.Larson, A.Laven; What Really Happened to the Class of '65?, 1977-78, NBC, d--include Irving, L.Penn, J.Starrett; and various 'pilot' films which did not develop into series, e.g. The Art of Crime, 1975 (exec.p/d); Cutter, 1972 (exec.p/d); Exo-Man, 1977 (exec.p/d).
3. For Marx, pp.183-84.
4. ibid., p.185.
5. Roland Barthes, Elements of Semiology, pp.89-90.
6. Sándor Hervey, Semiotic Perspectives, pp.136-37.
7. M.M. Bakhtin, The Dialogic Imagination, p.278.
8. ibid., p.279.
9. Chase, p.13.
10. ibid., p.14.
11. Leslie A. Fiedler, Love and Death in the American Novel, p.10.
12. ibid., p.24, quoted in Chase, p.15.
13. Fiedler, p.25.
14. 1969, TCF, sc--W.Goldman, d--G.R.Hill, l.p--P.Newman (Butch), R.Redford (Sundance)
15. The Deer Hunter, 1978, Columbia-EMI-Warner, sc--M.Cimino, D.Washburn and others, d--M.Cimino, l.p--R.DeNiro (Michael), C.Walken (Nick), M.Streep (Linda). Apocalypse Now, 1979, Columbia-Warner-Zoetrope, sc--J.Milius, sc/p/d--F.Coppola, l.p--M.Brande (Kurtz), M.Sheen (Willard), R.Duvall (Kilgore). These two films are the major landmarks of Hollywood's Vietnam in the 70s.

16. 1971, Universal, sc--J.B.Sherry, A.Maltz, p/d--D.Siegel, l.p--Eastwood (McBurney), Geraldine Page (Martha).
17. Chase, pp.15-16.
18. *ibid.*, p.18
19. Fredric Jameson, Marxism and Form, p.399.
20. See for example Philip Caputo, A Rumour of War, p.14, p.93, and *passim*.
21. Chase, p.17.
22. Louis Althusser, Essays in Self-Criticism, p.190.
23. For Marx, p.187.
24. For Marx, p.191.
25. Marx, 'Introduction (1857) to the Grundrisse', pp.72-73.
26. For Marx, p.191
27. Paul Hirst and Penny Woolley, Social Relations and Human Attributes, p.133.
28. For Marx, p.166.
29. Michel Foucault, The Archaeology of Knowledge, pp.144-45.
30. See Russell Jacoby, Social Amnesia, pp.3-4 and *passim*.
31. Roland Barthes, Mythologies, p.115.
32. Alan Sekula, 'On the Invention of Photographic Meaning', p.84.
33. For Marx, p.185.
34. 1975, MGM, exec.p--C.O'Connor, T.Becker, p--B.Geller, sc--A.Martinez, E.Waters, C.O'Connor, d--Richard Donner, l.p--Jack Palance (Bronkov), Dina Ousley (Ellen). Developed into a series: 1975-76, MGM, 60m, exec.p--C.O'Connor, B.Geller, d--include R.Donner, R.S.Badiyi, l.p--idem.
35. See Jim Kitses, Horizons West, pp.31-43.
36. Louis Althusser and Etienne Balibar, Reading Capital, p.37.
37. Stephen Heath, The Sexual Fix, p.38.
38. Critique, p.23.
39. For Marx, p.175.
40. Critique, p.19.
41. Douglas R. Hofstadter, Gödel, Escher, Bach: An Eternal Golden Braid, pp.684-719.

42. Timothy J. Reiss, 'Discursive Criticism and Epistemology', pp.38-39.
43. Reading Capital, p.62.
44. *ibid.*, p.63.
45. *ibid.*, p.62.
46. *ibid.*, p.61.
47. *ibid.*, p.60.
48. *ibid.*, p.60.
49. *ibid.*, p.63.
50. *ibid.*, pp.36-37.
51. In fact Althusser would define the latter structure as the real whereas the former conception of knowledge is a play on the words 'real object': 'This play on words plays on a difference it kills: at the same time it spirits away the corpse.' (*ibid.*p.40). What Althusser appears to mean here is that if the object of knowledge is a part of the real object then the distinction between the essential and the inessential parts of the real object is in fact a distinction between two different objects, the object of knowledge and the real object; the gold is not all there was but the rest has been 'spirited away'.
52. Reading Capital, p.43.
53. *ibid.*, p.52.
54. J-P Sartre, Search for a Method, p.169.
55. Critique, p.36.
56. *ibid.*, p.101.
57. Method, pp.174-75.
58. *ibid.*, p.175.
59. *ibid.*, p.8.
60. Critique, p.821.
61. 'Discursive Criticism and Epistemology', p.47.
62. Method, p.28.
63. *ibid.*, p.32.
64. Mark Poster, Sartre's Marxism, p.39.
65. Method, p.33, footnote no.9.
66. Garth Jackson Gillan, 'A Question of Method: History and Critical Experience', p.148, p.149, p.151, pp.152-53.

67. Method, p.164.
68. Reiss, 'Discursive Criticism and Epistemology', p.46.
69. Hofstadter, p.693.
70. Method, pp.162-64.
71. Hofstadter, p.709.
72. Reiss, p.46.
73. Hazel E. Barnes, Sartre and Flaubert, p.1.
74. Reiss, p.47.
75. Hofstadter, p.699.
76. ibid., p.709.

Chapter 6

Policing relations

1. Series: 1972-?, Lorimar/CBS, 60m, exec.p--L. Rich, E.Hamner, d--include H. Harris, R. Senensky, R. Butler, H. Hirschman, Gwen Arner.
2. This is the title of a book on the treatment of women in American film but more generally identifies a commonly held attitude about the changes in the Hollywood approach to its subjects. See Molly Haskell, From Reverence to Rape.
3. Alan Lovell, Don Siegel, p.38.
4. 1973, Warner, p/sc--W. P. Blatty, d--W. Friedkin, l.p--E. Burstyn (Chris), L. Blair (Regan), M. Von Sydow (Merrin).
5. Rental income from initial release period (\$m): 66.3, adjusted for inflation (x 1.4) = 92.8. See Anatomy of the Movies, edited by David Pirie, p.205, p.264.
6. Snow White and the Seven Dwarfs, 1937, Disney, d--D. Hand, animated feature. Rental income (\$m): 8, adjusted (x 10) = 80; Pirie, p.205.

7. 1982, p--E. and M. Lewis, sc--Costa-Gavras, D. Stewart, d--Costa-Gavras, l.p--J. Lemmon (Ed Horman), S.Spacek (Beth Horman), J. Shea (Charles Horman).
8. Gary Crowds, 'An Interview with Costa-Gavras', p.35
9. Critique, pp.233-234.
10. Police Story : The Jar, 1976, Columbia, exec.p--D. Gerber, p--L. O'Brien, sc--Sheldon Miles Willens, ph--E. Bergholz, d--Michael O'Herlihy, l.p--Don Meredith (Hagen), Christopher Connelly (Triplett), Rudy Solari (Terranova), Robert Mandan (Burns), Simon Oakland (Fanning). In series Police Story 1973-80, Columbia/NBC, 60m and 120m episodes, created by Joseph Wambaugh, developed for TV by E. J. Neuman, exec.p--S. Kallis, D. Gerber, d--include C. Allen, G. Nelson, J. Badham, V. Vogel, B. Shear.
11. Alias Smith and Jones, 1971-73, Universal/ABC, exec.p--R. Huggins, creator/p--G. Larson, d--include J. Arnold, A. Laven, B. Shear, V. Sherman. l.p--B.Murphy (Curry/Jones), P.Duel, R.Davis (Heyes/Smith).
Starsky and Hutch, 1975-79, exec.p--A. Spelling, L. Goldberg, p--J. T. Naar, d--include F. Lamas, B. Shear, G. McCowan, D. Weis, l.p--P. M. Glaser (Starsky), D.Soul (Hutchinson).
12. 1981, UA, sc--J. A. Fiskin, d--I. Passer, l.p--J. Heard (Cutter), J. Bridges (Bone), L. Eichhorn (Mo). Cutter chooses a representative figure of money and power to be 'responsible for everything' but is dead before the gun in his hand fulfils his mission.
13. Kojak : Wall Street Gunslinger, Universal, 1974, exec.p--M. Rapf, p--J. McAdams, sc--Halsted Wells, d--Richard Donner, l.p--Alan Feinstein (Lenny), Bernard Barrow (Paulus), Ann Coleman (Felicity), Trish Hawkins (Fern), in addition to the series regulars: Kojak, 1973-78, Universal/CBS, 60m, creator--A. Mann, d--include C. S. Dubin, J. Laird, C. Nyby, N. Sgarro, S. Neufeld, l.p--Telly Savalas (Kojak), Kevin Dobson (Crocker), Dan Frazer (Frank McNeil).

14. Baretta : Runway Cowboy, 1976, Universal, exec.p--A. Spinner, L. Vance, p--C. E. Dismukes, sc--Milt Rosen, d--Robert Douglas, l.p--Art Hindle (gigolo), Geraldine Brooks (judge), David Sheiner (Danzio), in addition to the series regulars: Baretta, 1975-78, Universal/ABC, 60m, creator--S. J. Cannell, exec.p--B. L. Kowalski, A. Spinner, d--include T. Post, R. Blake, V. Sherman, R. S. Badiyi, D. Medford, R. Douglas, l.p--Robert Blake (Baretta), Tom Ewell (Billy).
15. 1981, EMI, exec.p--R. Gimbel, T. Converse, p--S. Grosso, sc--Budd Schulberg, ph--B. West, m--B. Goldenberg, d--Jud Taylor, l.p--Ben Gazzara (Joe DeFalco), Robert Vaughn (Walker), Paul Sorvino (Danzie).
16. Vaughn's performance as an unscrupulous official is given an extra resonance by his prior role as the President's Chief of Staff (for which he received an Emmy Award) in Washington : Behind Closed Doors, 1977.
17. McMillan and Wife, 1971-76, Universal/NBC, 90/120m, exec.p--L. B. Stern, d--include G. Nelson, B. Shear, H. Averback, l.p--R. Hudson ('Mac') S. Saint James (Sally).
Hart to Hart, 1979-?, 60m, exec.p-- A. Spelling, L. Goldberg, d--include E. Bellamy, R. Senensky, l.p--R. Wagner (Jonathan), S. Powers (Jennifer).
18. Goldenberg's distinguished career as a composer for TV includes Alias Smith and Jones, 1970; Ransom for a Dead Man, 1971; The Marcus-Nelson Murders, 1973; Reflections of Murder, 1974; The Legend of Lizzie Borden, 1975; Helter Skelter 1976; James Dean, 1976; King, 1978.
19. 'When you've got to choose, every way you look at it you lose. Where have you gone, Joe Dimaggio? A nation turns its lonely eyes to you',--the intimations of moral suicide in Mrs. Robinson, words and music by Paul Simon, 1968.
20. Critique, p.583.
21. ibid., p.598.
22. ibid., p.624.
23. ibid., p.601.
24. ibid., p.606.
25. Method, p.113.

26. Critique, p.602.
27. ibid., p.630.
28. ibid., p.602.
29. ibid., p.648.
30. ibid., p.648.
31. ibid., p.649.
32. ibid., p.650.
33. Rental income from initial release period (\$m):
17.8, adjusted (x 1.5) = 26.7, See Pirie,
p.222.

Chapter 7

Imitative desire

1. 'Dog Day Afternoon as a Political Film', p.77.
2. Critique, p.671.
3. ibid., p.638.
4. ibid., p.632.
5. ibid., p.637.
6. Antonio Gramsci, Letters from Prison, p.204.
7. Lenin and Philosophy and Other Essays, p.138.
8. ibid., p.138.
9. ibid., p.138.
10. ibid., p.140.
11. Critique, p.737.
12. See Robert Gray, 'Bourgeois Hegemony in Victorian Britain', p.235.
13. R.D.Laing and D.G.Cooper, Reason and Violence,
p.136.
14. Critique, p.628.
15. ibid., p.39.
16. ibid., p.626.

17. This concern with possibilities undermines any hope of some final distillation of the work of the Critique's eight hundred pages and emphasises instead its richness and detail, against such accusations as that 'after thousands and thousands of words we end with what looks no better than a cliché', (Mary Warnock, 'Historical Explanation in "The Critique of Dialectical Reason"', p.107)
18. 'Dog Day Afternoon as a Political Film', p.90.
19. Psychology of Imagination, p.28.
20. *ibid.*, p.29.
21. *ibid.*, p.29.
22. *ibid.*, p.29.
23. *ibid.*, p.225.
24. Thomas R. Flynn, 'Sartre-Flaubert and the Real/Unreal', p.106.
25. Critique, p.109.
26. Fredric Jameson, Marxism and Form, p.243.
27. René Girard, Deceit, Desire, and the Novel, especially pp. 1-52.
28. *ibid.*, p.104.
29. *ibid.*, p.104.
30. 'Film Theory's Detour', p.72.
31. 'Dog Day Afternoon as a Political Film', p.91, figure 1, adapted.
32. Girard, pp.42-43.
33. Culture and Communication, p.67.
34. 1976-80, 60m, exec.p--A. Spelling, L. Goldberg, M. Nichols, d--include J. Broderick, Gwen Arner, M. Rydell, 1.p--J. Broderick (Doug Lawrence), S. Thompson (Kate Lawrence), M. Baxter Birney (Nancy).
35. John Fiske and John Hartley, Reading Television, p.175.
36. *ibid.*, p.90.
37. Leach, Culture and Communication, p.37.
38. Appropriately Kojak's superior, Chief of Detectives McNeil is a mothering figure who worries about Kojak ('I care, OK?') and does not display his authority to the degree that Kojak does to Crocker.

39. Girard, Deceit, Desire, and the Novel, p.15.
40. ibid., p.23.
41. Martin Williams, TV: The Casual Art, p.140.
42. It is not that cinema is enough in itself, but if there is cinema then there is also the whole stabilising network of ideological apparatuses.
43. Hélène Cixous, 'Castration or Decapitation?', p.43.
44. Reading Capital, p.37.
45. Semiotics and Interpretation , p.141.

Chapter 8

Knowledge and performance

1. The Imaginary Signifier, pp.4-5.
2. Essays in Self-Criticism , p.125.
3. For which Althusser was placed 'in a coffin marked "structuralism"...For a funeral it was a nice one. With this rather special characteristic: that the years have passed, but the ceremony is still going on', Essays in Self-Criticism, p.127.
4. ibid., p.129.
5. ibid., p.130.
6. The Chief Works of Benedict De Spinoza, p.75.
7. ibid., p.79.
8. ibid., p.79.
9. ibid., p.76.
10. ibid., p.75.
11. ibid., p.77.
12. ibid., p.81.
13. Essays in Self-Criticism, p.141.

14. 'It may be that in the course of his [the Marxist philosopher's] endeavours, even when he starts out from already established positions in order to attack open or disguised enemies, he will take up positions which in the course of the struggle are shown to be deviant positions, out of step with the correct line which he is aiming for', (Essays in Self-Criticism, p.144). Sartre's conception of the practico-inert suggests that such deviant positions become inevitably inscribed there.
15. Sartre, Search For a Method, p.163.
16. Critique, p.638.
17. The lineaments of such groups are detectable, for example, in the editorial board of Screen; at the Centre for Contemporary Cultural Studies; and around the contributors to Clarke and others, One-Dimensional Marxism, at different times and to varying degrees.
18. Essays in Self-Criticism, p.148.
19. Camera Lucida.
20. Spinoza, p.98.
21. *ibid.*, p.98.
22. *ibid.*, p.80.
23. *ibid.*, p.100.
24. *ibid.*, p.98.
25. *ibid.*, p.99.
26. Psychology of Imagination, p.23.
27. *ibid.*, p.23.
28. *ibid.*, p.23.
29. Spinoza, p.110.
30. *ibid.*, p.111.
31. *ibid.*, p.112.
32. Marx, 'Introduction (1857) to the Grundrisse', p.72.
33. Essays in Self-Criticism, p.136.
34. Errol E. Harris, 'Body-Mind Relation in Spinoza's Philosophy', p.20.

35. Marx's philosophical studies in Berlin during 1840-41 included Spinoza; see Texts on Method, edited by Carver, p.11.
36. 'Introduction (1857)', p.72.
37. *ibid.*, p.73.
38. Essays in Self-Criticism, p.189.
39. 'Introduction (1857)', pp.72-73.
40. Gödel, Escher, Bach, p.709.
41. 'Introduction (1857)', p.72.
42. Spinoza, p.114.
43. *ibid.*, p.117.
44. Ernest Sherman, 'Spinoza and the Divine Cogito: God as "Self-Performance"', p.37.
45. 'Introduction (1857)', p.48.
46. *ibid.*, p.73-74.
47. *ibid.*, p.73.
48. *ibid.*, p.77.
49. Marx and Engels, Collected Works, 3, pp.298-99.
50. Critique, p.75.
51. *ibid.*, p.76.
52. Search For a Method, p.173, footnote no.6.
53. See Hazel E. Barnes, Sartre and Flaubert, pp.248-50.
54. Critique, p.178.
55. *ibid.*, p.178.
56. *ibid.*, p.178. 'From this point of view, it is possible to accept both Durkheim's maxim and "treat social facts as things", and the response of Weber and many contemporaries, that "social facts are not things". That is to say, social facts are things insofar as all things are, directly or indirectly, social facts.' (Critique, p.179)
57. Search For a Method, p.174.
58. *ibid.*, p.174.
59. Sartre, 'A Plea For Intellectuals', pp.274- 75.
60. *ibid.*, p.277.
61. *ibid.*, p.277.

62. Search For a Method, p.113.
63. 'A Plea', p.280.
64. *ibid.*, p.280.
65. Search For a Method, p.113.
66. 'A Plea', p.278.
67. *ibid.*, p.284.
68. See Susan Sontag's preface to the translation of Writing Degree Zero for a compact account of this context.
69. An engagement in fact with Sartre's very specific notion of the writer's 'engagement'; see, for example, What is Literature, pp.13-14.
70. Psychology of Imagination, p.224.
71. Sartre and Flaubert, p.392.
72. Barthes, p.1.
73. Spinoza, p.263.
74. *ibid.* p.265.
75. Search For a Method, p.180.
76. Sherman, 'Spinoza and the Divine Cogito', p.41.
77. 1977, Columbia/NBC, exec.p--D. Gerber, sc--M. Rodgers, d--Virgil W. Vogel, l.p--James Farentino (Anderson), Glenn Ford (Hayes).
78. Farentino was at this point in his career a thoroughly familiar TV actor, specialising in trusty but vulnerable characters, winning an Emmy in the same year as this Police Story role for his performance as Simon Peter in Lew Grade's Jesus of Nazareth. See also, The Possessed, 1977 (as an ex-minister seeking salvation by destroying evil); Crossfire, 1975, (as a police undercover agent); Cool Million, 1972, (as an international private-eye); The Lawyers, series, 1969-72 (as protégé of a brilliant LA attorney).
79. Donald Spoto, Camerado : Hollywood and the American Man, p.173.
80. Narrative and Structure, p.12.
81. *ibid.*, p.47.
82. *ibid.*, p.48.
83. *ibid.*, p.52.

84. For a full transcription of the lyrics of The End, from The Door's 1967 debut album see Rock Voices, edited by Matt Damsker, pp.57-58.
85. 1956, sc--R. Bradbury, p/d--J. Huston, l.p--G. Peck (Ahab).
86. 1949, RKO, sc--F. Nugent, L. Stallings, p/d--J. Ford, l.p--J. Wayne (Brittles), Ben Johnson (Tyree).
87. Johnson is the cornerstone of what James Monaco calls 'the moody subtext of this elegy', American Film Now, p.143. The Last Picture Show, 1971, Columbia, sc--L. McMurty, P. Bogdanovich, d--Bogdanovich, l.p--J. Bridges (Duane), T. Bottoms (Sonny), Ben Johnson (Sam the Lion): N.B. the play on the word 'lion' in Hustle.
88. Mel Valley, Magnum Force, p.50.
89. Time, 31 May, 1971, p.43.
90. Peter Maas, Serpico, p.17.
91. 1939, Warner, sc--R. Buckner, d--M. Curtiz, l.p--E. Flynn (Wade).
92. For the flavour of the Leone/Eastwood collaboration see Iain Johnstone, The Man With No Name, pp.36-41 especially. N.B. p.37; Leone--'In my films I have more need of masks than great actors'.
93. Stars, pp.156-58.
94. James F. Scott, Film : The Medium and the Maker, p.240.
95. 1957, Paramount, sc--D.Nichols, d--A. Mann, l.p--H. Fonda (Hickman), A.Perkins (Owens). A brief analysis of the acting styles in this film is to be found in Scott, Film : Medium and the Maker, p.251.
96. The Actors Studio was established in New York in 1947 by Elia Kazan, Robert Lewis and Cheryl Crawford, as a rehearsal group. Under the directorship of Lee Strasberg it became the centre for exploration and development of techniques derived from Stanislavski's teaching. Particularly influential in the fifties it directly

shaped the prototypical 'Method' work of Brando, Clift and Dean but perhaps its most important current has been through Ben Gazzara, Rod Steiger, Joanne Woodward, Eli Wallach, Bruce Dern, Jack Nicholson, Ellen Burstyn, Jon Voight, etc.

97. 'Dog Day Afternoon as a Political Film', p.81.
98. Dyer, Stars, p.156.
99. From an interview with Bruce Dern in Joanmarie Kalter, Actors on Acting, p.185.
100. Scott, Film : The Medium and the Maker, p.251.
101. City of Words, p.18.
102. Quoted in City of Words, p.430.
103. 1973, Columbia/NBC, 120m, exec.p--D. Gerber, sc--M. Rodgers, d--R. Benedict, l.p--V. Morrow (LaFrieda)
104. 1949, Columbia, p/sc/d--R. Rossen, l.p--Broderick Crawford (Stark)
105. 1977, Tomorrow Entertainment, exec.p--T.W.Moore, p--P. Leaf, sc/d--Robert Collins, l.p--Edward Asner (Huey Long), Diane Kagan (Rose Long)
106. James Roosevelt with Bill Libby, My Parents, p.X.
107. Elliott Roosevelt and James Brough, A Rendezvous With Destiny, p.13.
108. James Roosevelt, p.8.
109. Dee Brown, The Westerners, p.275.
110. A Rendezvous With Destiny, p.82.
111. ibid., p.82.
112. 1975, Public Arts, p--R. Huggins, sc--S.J.Cannell, d--Don Medford, l.p--Wayne Rogers (Jake)
113. 1976, CKK, p--J. S. Kaplan, sc/d--John Carpenter, l.p--Austin Stoker (Ethan), Darwin Joston (Wilson), Laurie Zimmer (Leigh), Martin West (Lawson, the father)
114. 1956, Warner, sc--F. Nugent, d--John Ford, l.p--J. Wayne (Ethan), J. Hunter (Martin)
115. Brian Henderson, 'The Searchers : An American Dilemma', p.22.
116. ibid., p.22.

117. 1939, Columbia, sc--J. Furthman, p/d--H. Hawks, l.p--C. Grant (Jeff), J.Arthur (Bonnie Lee)
118. 1953, Paramount, sc--A. B. Guthrie, d--G. Stevens, l.p--A. Ladd (Shane), J. Arthur (Marion), J. Palance (Wilson)
119. John Carpenter in an interview in Tom Milne and Richard Combs, 'The Man in the Cryogenic Freezer', p.98.
120. Robin Wood, Howard Hawks, p.54, referring specifically to Feathers (Angie Dickinson) in Rio Bravo.
121. Critique, p.771.

Chapter 9

Postscript : reading

1. Harold Bloom and others, Deconstruction and Criticism, p.5.
2. On Deconstruction, pp.23-28.
3. 'Stevens' Rock and Criticism as Cure, II', pp.335-38.
4. Critique, p.624.
5. ibid., p.624.
6. ibid., p.623.
7. Search For a Method, p.164.
8. Writing and Difference, pp.280-81.
9. Roland Barthes by Roland Barthes; 'In what he writes, there are two texts', p.43.
10. Barthes, p.39.
11. 1974, UA, sc--Abby Mann, E. Tidyman, d--Milton Katselas.
12. Régis Durand, 'The Anxiety of Performance', p.169.
13. Dialectical Phenomenology: Marx's Method, p.10.
14. John O'Neill, 'Power and the Splitting (Spaltung) of Language', p.696.

15. For the distinction between the 'specific' and the 'universal' intellectual, see Foucault (Colin Gordon, ed.), Power/Knowledge pp.126-27
16. John O'Neill, Sociology as a Skin Trade, p.231, p.232, p.234, p.236.
17. Louis Althusser, Etienne Balibar, Reading Capital, p.211.
18. Consequences of Pragmatism, p.143.
19. See for example Barthes' comments on reading Marx in 'Roland Barthes : Bernard-Henri Lévy' (interview), pp.13-14.
20. Consequences of Pragmatism, p.153.
21. ibid., p.156.
22. Terry Eagleton, Literary Theory, p.196.
23. See Terry Lovell's attempt to bring it back to earth in Pictures of Reality.
24. Consequences of Pragmatism, p.158.
25. Harold Bloom, A Map of Misreading, p.60.
26. Consequences of Pragmatism, p.158.
27. Vincent B. Leitch, Deconstructive Criticism, p.132.
28. Eagleton, Literary Theory, p.150.
29. Leitch, p.140.
30. Dialectical Phenomenology, p.xii.
31. Félix Guattari, 'Everybody Wants to be a Fascist', p.91.
32. Gilles Deleuze, 'Three Group Problems', p.103.
33. ibid., p.105.
34. ibid., p.101.
35. Bologh, Dialectical Phenomenology, p.31.

Chapter 10

Narrative Reasoning and Emersonian Overflowing

1. Rare instances of simply given synchronic mediation in pictorial terms would be images of the Queen or the Pope, and even there certain narratives tend to be at work, as in Ulster's divided culture with its original mediator-actants, King Billy and King James.
2. A Theory of Semiotics, p.261.
3. The Political Unconscious, p.41.
4. *ibid.*, p.40.
5. Ralph Waldo Emerson, 'Nature'.
6. *ibid.*, pp.15-16.
7. *ibid.*, p.18.
8. *ibid.*, p.25.
9. *ibid.*, p.26.
10. *ibid.*, p.27.
11. *ibid.*, p.42.
12. *ibid.*, p.19.
13. *ibid.*, pp.37-38.
14. 'The Freshness of Transformation: Emerson's Dialectics of Influence', p.137.
15. 'Nature', pp.44-45.
16. The Breaking of the Vessels, p.75.
17. Paul Seydor, Peckinpah: The Western Films, p.242 (original source, Film World interview, 1970, p.89, no additional publication information given).
18. Love and Death in the American Novel, p.308
19. 'Ralph Waldo Emerson: An introduction', p.90.
20. 'The Method of Nature', p.131.
21. *ibid.*, p.131-32.
22. 'Ralph Waldo Emerson: An introduction', p.90.
23. Peckinpah: The Western Films, pp.241-42.

24. Tony Tanner, City of Words, pp.367-68.
25. Ancient Evenings, p.3, p.709.
26. Louis Althusser, Etienne Balibar, Reading Capital, pp.187-89.
27. For detailed discussion of spatial theories see, Charles Mercer, Living in Cities; Manuel Castells, The Urban Question: A Marxist Approach (Chapter 8, 'The Debate on the Theory of Space'); and Madeleine Davis, David Wallbridge, Boundary and Space: An introduction to the work of D. W. Winnicott.
28. Outline of a Theory of Practice, p.94.
29. For an argument on behalf of a third cinema see Fernando Solanas and Octavio Getino, 'Towards a Third Cinema'.
30. Pierre Bourdieu, Outline of a Theory of Practice, p.89.
31. The Ballad of Cable Hogue, 1970, Warner, sc--J. Crawford, E. Penney, p/d--Sam Peckinpah, l.p--Jason Robards (Cable), Stella Stevens (Hildy), David Warner (Joshua).
32. For discussion of Crusoe and economic individualism see Ian Watt, The Rise of the Novel, Chapter 3.
33. Music and lyrics by Richard Gillis.
34. Dialectic of Enlightenment, p.25.
35. ibid., p.28.
36. ibid., p.3.
37. ibid., pp.xv-xvi.
38. See Herbert Marcuse, 'Some Social Implications of Modern Technology'.
39. Dialectic of Enlightenment, p.4.
40. ibid., p.180, p.184.
41. ibid., pp.180-87.
42. See, for example, The Ethics, Prop. XXIX, Note.
43. Dialectic of Enlightenment, p.172.
44. Gregory Bateson, 'Bali: The Value System of a Steady State', p.86.
45. Claude Bremond, 'Postface' (1980) to 'The Logic of Narrative Possibilities', p.407.

46. In a sense Cable is briefly an internal mediator before the bank backs his scheme but he very quickly uses the water to assert his power within the power-structure of the stage-line and the bank.
47. Virgin Land: The American West as Symbol and Myth, p.181.
48. Capital, Volume 1, p.940.
49. Thomas R. Dew quoted in Henry Nash Smith, Virgin Land, p.207.
50. Virgin Land, p.208.
51. See Ronald T. Takaki, Iron Cages: Race and Culture in Nineteenth-Century America, pp.257-59.
52. *ibid.*, p.254.
53. For an immensely rich discussion of 'deterritorialization' see Gilles Deleuze and Félix Guattari, 'Balance Sheet - Program For Desiring-Machines'.
54. 'The Rhetoric of Temporality', p.190.
55. Meyer Abrams, quoted in Paul de Man, *ibid.*, p.179.
56. 'Some Social Implications of Modern Technology', p.159.
57. Political Power and Social Classes, p.219.
58. Paul de Man, Blindness and Insight, p.25.
59. Todd La Porte, C. J. Abrams, 'Alternative Patterns of Postindustria: The Californian Experience'.
60. Jeremy Tunstall, David Walker, Media Made in California, p.22.
61. *ibid.*, p.193.
62. See D. Thorns, 'Suburbia: Myth or Reality?'
63. On decentralization in the relevant period see Leo F. Schnore, 'The Functions of Metropolitan Suburbs'; 'Metropolitan Growth and Decentralization'; and 'Municipal Annexations and the Growth of Metropolitan Suburbs, 1950-60'.
64. Michael Pye, Lynda Myles, The Movie Brats, pp.30-31: See Part 2, 'The Playground Opens' for a discussion of the suburban 'change of mind'.
65. For an exemplary account of the publicity or selling machine, see Mike Gold, 'The Selling of the Man of Steel' (on Superman The Movie).

66. J. K. Galbraith, The New Industrial State, pp.70-71, pp.155-56, p.159.
67. Will Wright, Sixguns and Society, p.167.
68. Little Big Man, 1970, TCF, d--A. Penn;
The Godfather, 1972, Paramount, d--F. Coppola;
Jeremiah Johnson, 1972, Columbia-Warner, d--S. Pollack;
Pat Garrett and Billy the Kid, 1973, MGM d--S. Peckinpah;
The Missouri Breaks, 1976, UA, d--A. Penn;
Comes a Horseman, 1978, UA, d--A.J. Pakula;
The Warriors, 1979, Paramount, d--W. Hill
69. Jaws, 1975, Universal, p--R. D. Zanuck, D. Brown;
sc--P. Benchley, C. Gottlieb; d--S. Spielberg;
l.p--Roy Scheider (Brody), Robert Shaw (Quint),
Richard Dreyfuss (Hooper).
70. Beverley Brown, 'British Film Censorship - An
interview with James Ferman', pp.14-15.
71. 'Jaws as Patriarchal Myth', p.305.
72. Star Wars, 1977, TCF, d--G. Lucas;
Close Encounters of the Third Kind, 1977,
Columbia, d--S. Spielberg;
The Empire Strikes Back, 1980, TCF/Lucasfilm,
d--I. Kershner;
Raiders of the Lost Ark, 1981, Lucasfilm/Paramount,
d--S. Spielberg;
Return of the Jedi, 1983, Lucasfilm/TCF,
d--R. Marquand
73. See Chapters 4 and 8, above.
74. Andrew Gordon, 'Close Encounters: the Gospel
according to Steven Spielberg', p.162.
75. Dallas, series, 1978- , Lorimar; 'Jock' Ewing, the
owner of the Texas ranch and oil company dies
in a helicopter crash.
Knots Landing, series, 1979- , Lorimar; Sid Fairgate,
employer of Gary Ewing (son of 'Jock' in Dallas),
dies in a car crash.
76. 'Alternative Patterns of Postindustrial: The
Californian Experience', pp.40-45.
77. *ibid.*, p.42.
78. Ivan Szelenyi, 'The relative autonomy of the State
or state mode of production', p.589.

79. A Theory of Semiotics, pp.292-94.
80. Jacqueline Rose, 'Paranoia and the Film System',
p.92.
81. Iron Cages, pp.254-55.
82. *ibid.*, p.21.
83. Gilles Deleuze, 'Politics', pp.111-12
84. 1983, Warner, sc--J.C. Stinson, d/l.p--Clint
Eastwood (Harry), l.p--Sondra Locke (Jennifer)
85. Deleuze, p.100.
86. Prisms, p.87.
87. Béla Balázs, Theory of the Film, p.84, p.88.

BIBLIOGRAPHY

This bibliography is divided into two. The principle of selection is to include in the first section (pp.758-71) all works referred to in the text and notes while the second section (pp.772-84) includes only those uncited works which directly informed the composition of the text. No attempt is made to indicate more general intellectual debts.

Adorno, Theodor W., and Max Horkheimer, Dialectic of Enlightenment (London, 1979)

----- Prisms (Cambridge, Mass., 1981)

Albert, Steven 'Redemption of Discredited Authority', Jump Cut 26 (1981), 9-12

Althusser, Louis, Essays in Self-Criticism (London, 1976)

----- Lenin and Philosophy and Other Essays, second edition (London, 1977)

----- For Marx (London, 1977)

----- and Étienne Balibar, Reading Capital (London, 1979)

Altman, Rick, ed., Genre: The Musical (London, 1981)

Arlen, Michael J., The Camera Age: Essays on Television (New York, 1981)

Aron, Raymond, History and the Dialectic of Violence (Oxford, 1975)

Bakhtin, M.M., The Dialogic Imagination: Four Essays ed. by Michael Holquist (Austin, 1981)

Balázs, Béla, Theory of the Film: Character and Growth of a New Art (New York, 1970)

Barnes, Hazel E., Sartre and Flaubert (Chicago, 1981)

Barnouw, Erik, Tube of Plenty: The Evolution of American Television (New York: Galaxy reprint with additions, 1977)

----- The Sponsor: Notes on a Modern Potentate (New York: Galaxy reprint, 1979)

Barthes, Roland, Writing Degree Zero (New York, 1968)

----- Elements of Semiology (New York, 1968)

----- 'Science versus Literature', in Introduction to Structuralism, ed. by Michael Lane (New York, 1970), 410-416

----- 'The Structuralist Activity,' in The Structuralists from Marx to Lévi-Strauss ed. by Richard and Fernande De George (New York, 1972), 148-154

- Mythologies (St. Albans, 1973)
- S/Z (London, 1975)
- 'Change the Object Itself: Mythology today', in Image-Music-Text, ed. by Stephen Heath (Glasgow, 1977) 165-169
- Roland Barthes By Roland Barthes (New York, 1977)
- 'Textual Analysis of Poe's "Valdemar"', in Untying the Text: A Post-Structuralist Reader, ed. by Robert Young (Boston and London, 1981), 133-161
- Camera Lucida: Reflections on Photography (London, 1982)
- 'Roland Barthes: Bernard-Henri Lévy' (interview), Art and Text, 8 (1982), 8-20
- Bateson, Gregory, 'Bali: The Value System of a Steady State', in Steps to an Ecology of Mind: Collected Essays in Anthropology, Psychiatry, Evolution and Epistemology (London, 1973), 80-100
- Bazalgette, Cary, 'The Myth of Transparency in Film Study', Screen Education Notes, 10/11 (1974), 7-14
- Billington, Ray A., America's Frontier Culture: Three Essays (College Station, Texas, 1977)
- Birdwhistell, Ray L., Kinesics and Context: Essays on Body-Motion Communication (London, 1971)
- Bloom, Harold, 'The Freshness of Transformation: Emerson's Dialectics of Influence' in Emerson: Prophecy, Metamorphosis, and Influence, edited by David Levin (New York, 1975), 129-148
- and others, Deconstruction and Criticism (London, 1979)
- A Map of Misreading (New York, 1980)
- Bologh, Roslyn Wallach, Dialectical Phenomenology: Marx's Method (London, 1979)
- Bourdieu, Pierre, Outline of a Theory of Practice (Cambridge, 1977)
- Bremond, Claude, 'The Logic of Narrative Possibilities', including new 'Postface', New Literary History, XI, no. 3 (1980), 387-411

- Brooks, Peter, 'Fictions of the Wolfman: Freud and Narrative Understanding', Diacritics, 9, no.1 (1979), 72-81
- Brown, Beverley, 'British Film Censorship - An interview with James Ferman', Screen, 23, no.5 (1982), 2-25
- Brown, Dee, The Westerners (London, 1974)
- Buscombe, Edward, 'The Idea of Genre in the American Cinema', British Film Institute (Education Department) Study Unit 12: The Western, ed. by Ed Buscombe (London, 1971), 63-72 (reprinted from Screen, 2, no.2, 1970)
- Butler, Terence, Crucified Heroes: The Films of Sam Peckinpah (London, 1979)
- Campbell, Joseph, The Hero With a Thousand Faces, second edition (Princeton, 1968)
- Canby, Vincent, Review of The Wild Bunch, New York Times, 26 June 1969, p.45
- Review of 3 Into 2 Won't Go, New York Times, 3 July 1969, p.20
- Caputi, Jane E., 'Jaws as Patriarchal Myth', Journal of Popular Film, VI, no.4 (1978), 305-326
- Caputo, Philip, A Rumour of War (London, 1978)
- Carver, Terrell, ed., Karl Marx: Texts On Method (Oxford, 1975)
- Castells, Manuel, The Urban Question: A Marxist Approach (London, 1977)
- Chase, Anthony, 'The Strange Romance of "Dirty Harry" Callahan and Ann Mary Deacon', The Velvet Light Trap, 17 (1977), 13-18 (reprinted from TVLT, 4)
- Chase, Cynthia, 'Oedipal Textuality: Reading Freud's Reading of Oedipus', Diacritics, 9, no. 1 (1979), 54-68
- Chiodi, Pietro, Sartre and Marxism (Hassocks, Sussex, 1978)
- Cixous, Hélène, 'Castration or Decapitation?', Signs: Journal of Women in Culture and Society, 7, no. 11 (1981), 41-55
- Clarke, Simon, and others, One-Dimensional Marxism: Althusser and the Politics of Culture (London, 1980)
- Clarke, Simon, The Foundations of Structuralism: A Critique of Lévi-Strauss and the Structuralist Movement (Brighton, 1981)

- Cohen, Morris R., and Ernest Nagel, An Introduction to Logic and Scientific Method, complete edition (London, 1934)
- Comolli, Jean-Louis and Jean Narboni, 'Cinema/Ideology/Criticism (1)', Screen Reader 1 (1977), 2-11
- Crowdus, Gary, 'The Missing Dossier: An Interview with Costa-Gavras', Cineaste, XII, no. 1 (1982), 30-35
- Culler, Jonathan, Structuralist Poetics: Structuralism, Linguistics and the Study of Literature (London, 1975)
- On Deconstruction: Theory and Criticism after Structuralism (London, 1983)
- Damsker, Matt, ed., Rock Voices: The Best Lyrics of an Era (London, 1981)
- Davis, Madeleine, and David Wallbridge, Boundary and Space: An Introduction to the work of D. W. Winnicott, revised edition, (Harmondsworth, 1983)
- Deleuze, Gilles, 'Three Group Problems', Semiotext(e), II, no.3 (1977), 99-109
- and Félix Guattari, 'Balance Sheet - Program For Desiring-Machines', Semiotext(e), II, no.3 (1977), 117-135
- 'Politics', in On the Line by Gilles Deleuze and Félix Guattari (New York, 1983), 69-115
- De Man, Paul, 'The Rhetoric of Temporality', in Interpretation: Theory and Practice, ed. by Charles Singleton (Baltimore, 1969), 173-209
- Blindness and Insight: Essays in the Rhetoric of Contemporary Criticism, second edition, revised (London, 1983)
- Derrida, Jacques, Writing and Difference (London, 1978)
- Derry, Charles, Dark Dreams: A Psychological History of the Modern Horror Film (Cranbury, N.J., 1977)
- Douglas, Mary, Natural Symbols: Explorations in Cosmology (Harmondsworth, 1978)
- Dundes, Alan, 'Structuralism and Folklore', in Studia Fennica, no. 20, Folk Narrative Research: Some Papers Presented at the VI Congress of the International Society for Folk Narrative Research (1976), 75-93

- Durand, Régis, 'The Anxiety of Performance', New Literary History, XII, no. 1 (1980) 167-176
- Dyer, Richard, Stars (London, 1979)
- Eagleton, Terry, Literary Theory: An Introduction (Oxford, 1983)
- Eco, Umberto, 'Articulations of the Cinematic Code', in Movies and Methods: An Anthology, ed. by Bill Nichols (Berkeley, 1976), 590-607
- A Theory of Semiotics (London, 1977)
- The Role of the Reader: Explorations in the semiotics of texts (London, 1981)
- Emerson, Ralph Waldo, 'Nature', and 'Addresses: The Method of Nature', in The Collected Works of Ralph Waldo Emerson, text established by Alfred R. Ferguson, notes by Robert E. Spiller (Cambridge, Mass., 1971), 7-45, 117-137
- Etulain, Richard W., 'The American Literary West and Its Interpreters: The Rise of a New Historiography', in The Western: A Collection of Critical Essays, ed. by James K. Folsom (Englewood Cliffs, 1979), 137-171
- Fiedler, Leslie A., Love and Death in the American Novel (London, 1970)
- Fiske, John, and John Hartley, Reading Television (London, 1978)
- Flynn, Thomas R., 'Sartre-Flaubert and the Real/Unreal', in Jean-Paul Sartre: Contemporary Approaches to His Philosophy, ed. by Hugh J. Silverman and Frederick A. Elliston (Brighton, 1980), 105-123
- Forster, E. M., Aspects of the Novel (Harmondsworth, 1972)
- Foucault, Michel, The Archaeology of Knowledge (London, 1974)
- Power/Knowledge: Selected Interviews and Other Writings 1972-1977, ed. by Colin Gordon (Brighton, 1980)
- The History of Sexuality: Volume 1, An Introduction (Harmondsworth, 1981)
- French, Philip, 'The Indian in the Western Movie', in The Pretend Indians: Images of Native Americans in the Movies, ed. by Gretchen M. Bataille and Charles L.P. Silet (Ames, Iowa, 1980), 98-105

- Freud, Sigmund, 'From the History of an Infantile Neurosis (The "Wolf Man")', in Pelican Freud Library, 9, Case Histories II, ed. by Angela Richards (1979), 227-366
- Galbraith, John Kenneth, The New Industrial State (Boston, 1967)
- Georgakas, Dan, 'They Have Not Spoken: American Indians in Film', in The Pretend Indians: Images of Native Americans in the Movies, ed. by Gretchen M. Bataille and Charles L. P. Silet (Ames, Iowa, 1980), 134-142
- Gillan, Garth Jackson, 'A Question of Method: History and Critical Experience', in Jean-Paul Sartre: Contemporary Approaches to His Philosophy, ed. by Hugh J. Silverman, Frederick A. Elliston (Brighton, 1980), 141-154
- Girard, René, Deceit, Desire, and the Novel: Self and Other in Literary Structure, (Baltimore, 1965)
- Gold, Mike, 'The Selling of The Man of Steel', Fantastic Films, 2, no. 1 (1979), 6-12, 26-27, 50-51, 59
- Gordon, Andrew, 'Close Encounters: The Gospel According to Steven Spielberg', Literature/Film Quarterly, VIII, no. 3 (1980), 156-164
- Gordon, Colin, 'The subtracting machine', I & C, 8, Power and desire: diagrams of the social (1981), 27-40
- Gorz, André, Farewell to the Working Class: an Essay on Post-Industrial Socialism (London, 1982)
- Gramsci, Antonio, Letters from Prison, ed. by Lynne Lawner (London, 1975)
- Gray, Robert, 'Bourgeois hegemony in Victorian Britain', in Culture, Ideology and Social Process: A Reader, ed. by Tony Bennett and others (London, 1981), 235-250
- Greimas, A.J., and F. Rastier, 'The Interaction of Semiotic Constraints', Yale French Studies, 41 (1968), 86-105
- Guattari, Félix, 'Everybody Wants to be a Fascist', Semiotext(e), II, no. 3 (1977), 87-98
- Hacker, Louis M., 'Sections - Or Classes?', in The Turner Thesis: Concerning the Role of the Frontier in American History, ed. by George Rogers Taylor, third edition, (Lexington, Mass., 1972), 51-56

- Harris, Errol E., 'Body-Mind Relation in Spinoza's Philosophy', in Spinoza's Metaphysics: Essays in Critical Appreciation, ed. by James B. Wilbur (Assen, 1976), 13-28
- Haskell, Molly, From Reverence to Rape: The Treatment of Women in the Movies (New York, 1974)
- Heath, Stephen, 'The Question Oshima', in Ophuls, ed. by Paul Willemsen (London, 1978), 75-87
- Questions of Cinema (London, 1981)
- The Sexual Fix (London, 1982)
- Henderson, Brian, 'The Searchers: An American Dilemma', Film Quarterly, XXXIV, no. 2 (1980-81), 9-23
- Hervey, Sándor, Semiotic Perspectives (London, 1982)
- Hirst, Paul, and Penny Woolley, Social Relations and Human Attributes (London, 1982)
- Hobson, Dorothy, Crossroads: The Drama of a Soap Opera (London, 1982)
- Hofstadter, Douglas R., Gödel, Escher, Bach: an Eternal Golden Braid (Harmondsworth, 1980)
- Holloway, John, Narrative and Structure: exploratory essays (Cambridge, 1979)
- Jacoby, Russell, Social Amnesia: A Critique of Conformist Psychology from Adler to Laing (Hassocks, Sussex, 1977)
- Jakobson, Roman, 'Linguistics and Poetics', in The Structuralists from Marx to Lévi-Strauss, ed. By Richard and Fernande De George (New York, 1972), 85-122
- Jameson, Fredric, Marxism and Form: Twentieth-Century Dialectical Theories of Literature (Princeton, 1971)
- 'Dog Day Afternoon as a Political Film', Screen Education, 30 (1979), 75-92
- The Political Unconscious: Narrative As a Socially Symbolic Act (London, 1981)
- Johnstone, Iain, The Man With No Name: The Biography of Clint Eastwood (London, 1981)
- Kael, Pauline, Kiss Kiss Bang Bang (London, 1970)

- When the Lights Go Down (London, 1980)
- Kalter, Joanmarie, Actors on Acting: Performing in Theatre and Film Today (New York, 1979)
- Kaminsky, Stuart M., American Film Genres: Approaches to a Critical Theory of Popular Film (New York: Laurel reprint, 1977)
- Kermode, Anita, 'Ralph Waldo Emerson: An introduction', in Teaching the text ed. by Susanne Kappeler and Norman Bryson (London, 1983), 73-91
- Kitses, Jim, Horizons West: Anthony Mann, Budd Boetticher, Sam Peckinpah: studies of Authorship within the Western (London, 1969)
- Klein, Melanie, 'Our Adult World and its Roots in Infancy', Human Relations, XII, no. 4 (1959), 291-303
- Knopf, Terry Ann, 'Sniping - A New Pattern of Violence?', Trans-action, 6, no. 9 (1969), 22-29
- Kritzman, Lawrence, 'A.J. Greimas and Narrative Semiotics', in The Sign: Semiotics Around the World, ed. by R. W. Bailey, L. Matejka and P. Steiner (Ann Arbor, 1980), 258-270
- Laing, R. D., and D. G. Cooper, Reason and Violence: A Decade of Sartre's Philosophy, 1950-1960, second edition (London, 1971)
- Lakatos, Imre, The Methodology of Scientific Research Programmes, Philosophical Papers, Volume I (Cambridge, 1978)
- Lane, Michael, ed., Introduction to Structuralism, (New York, 1970)
- La Porte, Todd, and C. J. Abrams, 'Alternative Patterns of Postindustria: The Californian Experience', in Politics and the Future of Industrial Society, ed. by Leon N. Lindberg (New York, 1976), 19-56
- Leach, Edmund, 'Structuralism in Social Anthropology', in Structuralism: an introduction, ed. by David Robey (Oxford, 1973), 37-56
- Culture and Communication (Cambridge, 1976)
- Leitch, Vincent B., Deconstructive Criticism: An Advanced Introduction (New York, 1983)

- Lévi-Strauss, Claude, The Savage Mind (La Pensée Sauvage)
(London, 1966)
- The Raw and the Cooked: Introduction to a Science of
Mythology (Mythologiques) I (London, 1970)
- Structural Anthropology (Harmondsworth: Peregrine Books
reissue, 1977)
- Lovell, Alan, Don Siegel: American Cinema (London, 1975)
- Lovell, Terry, Pictures of Reality: Aesthetics, Politics,
Pleasure (London, 1980)
- McArthur, Colin Underworld U.S.A. (London, 1972)
- McKinney, Doug, Sam Peckinpah (Boston, 1979)
- MacCabe, Colin, (With Mick Eaton and Laura Mulvey),
Godard: Images, Sounds, Politics (London, 1980)
- Maas, Peter, Serpico (Glasgow, 1974)
- Mailer, Norman, Why Are We In Vietnam? (London, 1969)
- Ancient Evenings (London, 1983)
- Maranda, Elli Köngäs, and Pierre Maranda, Structural Models
in Folklore and Transformational Essays, Approaches to
Semiotics, ed. by T. A. Sebeok, no. 10 (The Hague, 1971)
- Marcuse, Herbert, 'Some Social Implications of Modern Technology',
in The Essential Frankfurt School Reader, ed. by Andrew
Arato and Eike Gebhardt (Oxford, 1978), 138-162
- Marill, Alvin H., Movies Made For Television: The Telefeature
and the Mini-Series (Westport, Conn., 1980)
- Marx, Karl, and Frederick Engels, Collected Works, Volume 3,
Marx and Engels: 1843-44 (London, 1975)
- Marx, Karl, 'Introduction (1857) to the Grundrisse', in
Karl Marx: Texts on Method, ed. by Terrell Carver
(Oxford, 1975), 46-87
- Capital: A Critique of Political Economy, Pelican Marx
Library, Volume One (Harmondsworth, 1976)
- Matejka, Ladislav, 'Postscript: Prague School Semiotics', in
Semiotics of Art: Prague School Contributions, ed. by
Ladislav Matejka and Irwin R. Titunik (Cambridge, Mass.,
1976), 265-290

- Mercer, Charles, Living in Cities: Psychology and the Urban Environment (Harmondsworth, 1975)
- Metz, Christian, 'History/Discourse: Note on two Voyeurisms', Edinburgh '76 Magazine (1976), 21-25
- The Imaginary Signifier: Psychoanalysis and the Cinema (Bloomington, 1982)
- Meyers, Richard, T V Detectives (San Diego, 1981)
- Miller, J. Hillis, 'Stevens' Rock and Criticism as Cure' (part II), Georgia Review, 30 (1976), 330-4 8
- Milne, Tom, and Richard Combs, 'The Man in the Cryogenic Freezer', Sight and Sound, 47, no.2 (1978), 94-98
- Modleski, Tania, 'Film Theory's Detour', Screen, 23, no. 5 (1982), 72-79
- Monaco, James, American Film Now: The People, The Power, The Money, The Movies (New York, 1979)
- Morgan, D. H. J., Social Theory and the Family (London, 1975)
- O'Neill, John, Sociology as a Skin Trade: Essays towards a reflexive sociology, (London, 1972)
- 'Power and the Splitting (Spaltung) of Language', New Literary History, XIV, no. 3 (1983), 695-710
- Pepper, Stephen C., Concept and Quality: A World Hypothesis (La Salle, Illinois, 1967)
- Pirie, David, ed., Anatomy of the Movies (London, 1981)
- Polhemus, Ted, 'Social Bodies', in The Body as a Medium of Expression, ed. by Jonathan Benthall and Ted Polhemus (London, 1975), 13-35
- Poole, Roger, 'Objective Sign and Subjective Meaning', in The Body as a Medium of Expression, ed. by Jonathan Benthall and Ted Polhemus (London, 1975), 74-104
- Poster, Mark, Sartre's Marxism (London, 1979)
- Poulantzas, Nicos, Political Power and Social Classes (London: Verso edition, 1978)
- Propp, V., Morphology of the Folktale, second edition (Austin, 1977)

- Pye, Michael, and Lynda Myles, The Movie Brats: How the Film Generation Took Over Hollywood (London, 1979)
- Reiss, Timothy J., 'Discursive Criticism and Epistemology', in Interpretation of Narrative, ed. by Mario J. Valdés and Owen J. Miller (Toronto, 1978), 38-47
- Rimmon-Kenan, Shlomith, Narrative Fiction: Contemporary Poetics (London, 1983)
- Roosevelt, Elliott (and Brough, James,) A Rendezvous with Destiny: The Roosevelts of the White House (London, 1977)
- Roosevelt, James (with Libby, Bill,) My Parents: A Differing View (London, 1977)
- Rorty, Richard, Consequences of Pragmatism (Essays:1972-1980) (Brighton, 1982)
- Rose, Jacqueline, 'Paranoia and the Film System', Screen, 17, no. 4 (1976/7), 85-104
- Rosenfeld, Howard M., 'Measurement of body motion and orientation', in Handbook of Methods in Nonverbal Behaviour Research, ed. by Klaus R. Scherer and Paul Ekman (Cambridge, 1982), 199-286
- Runciman, W. G., 'What is structuralism?', British Journal of Sociology, 20 (1969), 253-265
- Ryall, Tom, 'Teaching through Genre', Screen Education, 17 (1975), 27-33
- Said, Edward W., Beginnings: Intention and Method (Baltimore, 1978)
- Sarris, Andrew, The John Ford Movie Mystery (London, 1976)
- Sartre, Jean-Paul, What Is Literature? (London, 1967)
- Search For a Method (New York, 1968)
- The Psychology of Imagination (London, 1972)
- 'A Plea for Intellectuals', in Between Existentialism and Marxism (London, 1974), 228-285
- Critique of Dialectical Reason I: Theory of Practical Ensembles, ed. by Jonathan Rée (London, 1976)
- Schickel, Richard, 'Good Ole Burt; Cool-Eyed Clint', cover story, Time, 9 January 1978, pp. 42-48

- Schnore, Leo F., 'The Functions of Metropolitan Suburbs',
American Journal of Sociology, LXI, no. 5 (1956),
453-458
- 'Metropolitan Growth and Decentralization',
American Journal of Sociology, LXIII, no. 2
(1957), 171-180
- 'Municipal Annexations and the Growth of Metropolitan
Suburbs, 1950-60' American Journal of Sociology,
LXVII, no. 4 (1962), 406-417
- Scholes, Robert, Semiotics and Interpretation (New Haven,
1982)
- Scott, James F., Film: The Medium and the Maker (New York,
1975)
- Searle, John R., Intentionality: An essay in the philosophy
of mind (Cambridge, 1983)
- Sekula, Allan, 'On the Invention of Photographic Meaning',
in Thinking Photography ed. by Victor Burgin (London,
1982), 84-109
- Seydor, Paul, Peckinpah: The Western Films (Urbana, 1980)
- Sherman, Ernest, 'Spinoza and the Divine Cogito: God as
"Self-Performance"', in Spinoza's Metaphysics:
Essays in Critical Appreciation, ed. by James B. Wilbur
(Assen, 1976), 36-43
- Slotkin, Richard, Regeneration Through Violence: The Mythology
of the American Frontier, 1600-1860 (Middletown, Conn.,
1973)
- Smith, Henry Nash, Virgin Land: The American West as Symbol
and Myth (Cambridge, Mass., 1950)
- Sperber, Dan, 'Claude Lévi-Strauss', in Structuralism and
Since: From Lévi-Strauss to Derrida ed. by John Sturrock
(Oxford, 1979), 19-51
- Spinoza, Benedict De, The Chief Works of Benedict De Spinoza,
Volume II (London 1906). Pagination in the Dover edition,
1955, corresponds.
- Spoto, Donald, Camerado: Hollywood and the American Man
(New York, 1978)
- Sulloway, Frank J., Freud, Biologist of the Mind: Beyond the
Psychoanalytic Legend (London: Fontana reprint, 1980)
- Swarthout, Glendon, The Shootist (London, 1975)

- Szelenyi, Ivan, 'The relative autonomy of the State or state mode of production?', in Urbanization and Urban Planning in Capitalist Society (London, 1981), 565-591
- Takaki, Ronald T., Iron Cages: Race and Culture in Nineteenth-Century America (London, 1980)
- Tanner, Tony, City of Words: American Fiction 1950-1970 (London, 1976)
- Terrace, Vincent, Television 1970-1980 (San Diego, 1981)
- Thomson, David, A Biographical Dictionary of the Cinema (London, 1975)
- Thorns, D., 'Suburbia: Myth or Reality?', in Urban Change and Conflict: An Interdisciplinary Reader, ed. by Andrew Blowers and others (London, 1982)
- Time, 'Indecent Exposure on Capitol Hill', 7 June 1976, pp. 24-25. 'Sex Scandal Shakes Up Washington', 14 June 1976, pp. 25-27. 'Warm Words from Jimmy Cardigan', 14 February 1977, p. 34
- Tudor, Andrew, Theories of Film (London, 1974)
- Tunstall, Jeremy, and David Walker, Media Made In California: Hollywood, Politics and the News (New York, 1981)
- Turner, Frederick Jackson, 'The Significance of the Frontier in American History' and 'The West and American Ideals', reprinted in The Frontier in American History by F. J. Turner (New York, 1920), 1-38, 290-310
- Valley, Mel, Magnum Force (based on the screenplay by John Milius and Michael Cimino), (London, 1978)
- Van Hooff, J. A. R. A. M., 'Categories and sequences of behaviour: methods of description', in Handbook of Methods in Nonverbal Behaviour Research, ed. by Klaus R. Scherer and Paul Ekman (Cambridge, 1982), 362-439
- Vico, Giambattista, The New Science, revised translation of the third edition (1744) by Thomas Goddard Bergin and Max Harold Fisch (Ithaca, N. Y., 1968)
- Warshow, Robert, 'The Westerner', in Film: An Anthology, ed. by Daniel Talbot (Berkeley, 1959), 148-162
- Watt, Ian, The Rise of the Novel: Studies in Defoe, Richardson and Fielding (Harmondsworth: Pelican reissue, 1972)
- Wilkinson, Paul, The New Fascists, revised edition (London, 1983)

Williams, Christopher, ed., Realism and the Cinema: A Reader
(London, 1980)

Williams, Martin, T.V: The Casual Art (New York, 1982)

Wood, Robin, Howard Hawks (London, 1968)

Wright, Will, Sixguns and Society: A Structural Study of
the Western (Berkeley, 1975)

Section 2

- Adorno, Theodor W., 'Freudian Theory and the Pattern of Fascist Propaganda', in The Essential Frankfurt School Reader, ed. by Andrew Arato and Eike Gebhardt (New York, 1978), 118-137
- Aronson, Ronald, 'The Individualist Social Theory of Jean-Paul Sartre', in Western Marxism : A Critical Reader, ed. by New Left Review (London, 1978), 201-231
- Balibar, Etienne, and Pierre Macherey, 'On Literature as an Ideological Form', in Untying the Text : A Post-Structuralist Reader, ed. by Robert Young (Boston and London, 1981), 79-99
- Barnes, Hazel E., Sartre (London, 1973)
- Barthes, Roland, The Pleasure of the Text (New York, 1975)
- , 'Theory of the Text', in Untying the Text : A Post-Structuralist Reader, ed. by Robert Young (Boston and London, 1981), 31-47
- Baudry, Jean-Louis, 'Writing, Fiction, Ideology', Afterimage, 5 (1974), 22-39
- , 'Ideological Effects of the Basic Cinematographic Apparatus', 'The Apparatus' and 'Author and Analyzable Subject', in Apparatus - Cinematographic Apparatus : Selected Writings, ed. by Theresa Hak Kyung Cha (New York, 1980), 25-83
- Bell, Philip, 'Identification in a Film of Social Control : Siegel's Dirty Harry', Australian Journal of Screen Theory, 5/6 (1978), 163-192
- Bellour, Raymond, 'Cine-Repetitions', Screen, 20, no. 2 (1979), 65-72
- Belsey, Catherine, Critical Practice (London, 1980)
- Benjamin, Walter, 'On Some Motifs in Baudelaire', in Illuminations (Glasgow, 1973), 157-202
- Bernstein, Basil, 'Class and Pedagogies : Visible and Invisible', in Power and Ideology in Education, ed. by Jerome Karabel and A.H. Halsey (New York, 1977), 511-534
- Bettetini, Gianfranco, The Language and Technique of the Film, Approaches to Semiotics, ed. by T.A. Sebeok, no. 28 (The Hague, 1973)
- Bloch, Ernst, 'A Philosophical View of the Detective Novel', Discourse, 2 (1980), 32-51
- Bloom, Harold, Poetry and Repression : Revisionism from Blake to Stevens (New Haven, 1976)
- , The Breaking of the Vessels (Chicago, 1982)

- Bocock, Robert, Freud and Modern Society : An outline and analysis of Freud's sociology (Walton-on-Thames, 1976)
- Bottomore, Tom, and Patrick Goode, eds., Readings In Marxist Sociology (Oxford, 1983)
- Bourdieu, Pierre, 'Structuralism and Theory of Sociological Knowledge', Social Research, 35, no. 4 (1968), 681-706
- , 'Public Opinion Does Not Exist', in Communication and Class Struggle : 1. Capitalism, Imperialism, ed. by Armand Mattelart and Seth Siegelau (New York, 1979), 124-130
- Bracken, H.M., 'Essence, accident and race', Hermathena, CXVI (1973), 81-96
- Brooks, Peter, 'Freud's Masterplot', Yale French Studies, 55/56 (1977), 280-300
- Browne, Nick, 'Cahiers du Cinema's Rereading of Hollywood Cinema : An Analysis of Method', Quarterly Review of Film Studies, 3, no. 3 (1978), 405-416
- Burch, Noël, 'How we got into Pictures : notes accompanying Correction Please', Afterimage, 8/9 (1981), 24-38
- Burniston, Steve, and Chris Weedon, 'Ideology, Subjectivity and the Artistic Text', in On Ideology, ed. by an editorial group at the Centre for Contemporary Cultural Studies, University of Birmingham (London, 1977), 199-229
- Burniston, Steve, Frank Mort and Christine Weedon, 'Psychoanalysis and the cultural acquisition of sexuality and subjectivity', in Women Take Issue : Aspects of Women's Subordination, ed. by Women's Studies Group, Centre for Contemporary Cultural Studies, University of Birmingham (London, 1978), 109-131
- Callinicos, Alex, Althusser's Marxism (London, 1976)
- , Marxism and Philosophy (Oxford, 1983)
- Carroll, John M., Toward a Structural Psychology of Cinema, Approaches to Semiotics, ed. by T.A. Sebeok and others, no. 55 (The Hague, 1980)
- Cawelti, John G., The Six-Gun Mystique (Bowling Green, Ohio, 1971)
- Chatman, Seymour, 'On the Formalist-Structuralist Theory of Character', Journal of Literary Semantics, 1 (1972), 57-79
- Clarens, Carlos, Crime Movies : From Griffith to the Godfather and Beyond (London, 1980)
- Clark, Gordon, and Michael Dear, 'The State in capitalism and the capitalist State', in Urbanization and Urban Planning in Capitalist Society, ed. by Michael Dear and Allen J. Scott (London, 1981) 45-61

- Cohen, G.A., Karl Marx's Theory of History : A Defence (Oxford, 1978)
- Combs, Richard, Robert Aldrich (London, 1978)
- Comolli, Jean-Louis, 'Technique and Ideology : Camera, Perspective, Depth of Field', Film Reader, 2 (1977), 128-140
- , 'Machines of the Visible', in The Cinematic Apparatus, ed. by Teresa de Lauretis and Stephen Heath (London, 1980), 121-142
- Corrigan, Phillip, 'What is The Subject of (a) Cultural Production?', Undercut, 3/4 (1982), 56-59 (footnotes, 68)
- Coward, Rosalind, and John Ellis, Language and Materialism : Developments in Semiology and the Theory of the Subject (London, 1977)
- Coward, Rosalind, Patriarchal precedents : Sexuality and social relations (London, 1983)
- Culler, Jonathan, The Pursuit of Signs : Semiotics, Literature, Deconstruction (London, 1981)
- Deely, John, 'The Doctrine of Signs : Taking Form at Last : A propos of A Theory of Semiotics by Umberto Eco', Semiotica, 18, no. 2 (1976), 171-193
- , Introducing Semiotic : Its History and Doctrine (Bloomington, 1982)
- De La Haye, Yves, 'Introduction : contribution to a materialist analysis of the media', in Marx and Engels on the Means of Communication, ed. by Yves de la Haye (New York, 1979), 9-55
- De Lauretis, Teresa, 'Semiotics, Theory and Social Practice : A critical history of Italian semiotics', Cine-Tracts, 2, no. 1 (1978), 1-14
- , 'A Semiotic Approach to Television as Ideological Apparatus', in Television : The Critical View, ed. by Horace Newcomb (New York, 1979), 107-117
- , 'Imaging', Cine-Tracts, 3, no. 3 (1980), 3-12
- Deleuze, Gilles, and Félix Guattari, Anti-Oedipus : Capitalism and Schizophrenia (New York, 1977)
- De Man, Paul, 'Symbolic Landscape in Wordsworth and Yeats', in In Defense of Reading : A Reader's Approach to Literary Criticism, ed. by Reuben A. Brower and Richard Poirier (New York, 1962), 22-37
- , 'Intentional Structure of the Romantic Image', in Romanticism and Consciousness : Essays in Criticism, ed. by Harold Bloom (New York, 1970), 65-77
- , 'The Resistance to Theory', Yale French Studies, 63 (1982), 3-20
- Derrida, Jacques, 'The Purveyor of Truth', Yale French Studies, 52 (1975), 31-113

- Derrida, Jacques, 'Semiology and Grammatology : Interview with Julia Kristeva', in Positions, ed., with critical notes, by Alan Bass (London, 1981), 15-36 (notes, 98-99)
- Detweiler, Robert, Story, Sign, and Self : Phenomenology and Structuralism as Literary - Critical Methods (Philadelphia, 1978)
- Doane, Mary Ann, 'The Voice in the Cinema : The Articulation of Body and Space', Yale French Studies, 60 (1980), 33-50
- , 'Film and the Masquerade : Theorising the Female Spectator', Screen, 23, nos. 3/4 (1982), 74-87
- Dorfman, Richard, 'Conspiracy City', Journal of Popular Film and Television, VII, no. 4 (1980), 434-456
- Douglas, Mary, 'Cultural Bias' in In the Active Voice (London, 1982), 183-254
- Dyer, Richard, 'The Role of Stereotypes', in Images of Alcoholism, ed. by Jim Cook and Mike Lewington (London, 1979), 15-21
- Eagleton, Terry, Criticism and Ideology : A Study in Marxist Literary Theory (London, 1976)
- Easthope, Antony, 'The Trajectory of Screen, 1971-79', in The Politics of Theory : Proceedings of the Essex conference on the Sociology of Literature July 1982, ed. by Francis Barker and others (Colchester, 1983), 121-133
- Eco, Umberto, 'On the Contribution of Film to Semiotics', Quarterly Review of Film Studies, 2, no. 1 (1977), 1-14
- , 'Semiotics of Theatrical Performance', The Drama Review, 21, no. 1 (1977), 107-117
- Eikhenbaum, Boris, 'Problems of Film Stylistics', Screen, 15, no. 3 (1974), 7-31
- , ed., The Poetics of Cinema, with a preface by K. Shutko, Russian Poetics in Translation, 9 (1982), edited by Richard Taylor
- Elam, Keir, The Semiotics of Theatre and Drama (London, 1980)
- Ellis, John, Visible Fictions : Cinema : Television : Video (London, 1982)
- Elsaesser, Thomas, 'Narrative Cinema and Audience-Oriented Aesthetics', in Popular Television and Film, ed. by Tony Bennett and others (London, 1981), 270-282
- Espinosa, Julio Garcia, 'For an imperfect cinema', Jump Cut, 20 (1979), 24-26
- Falkenberg, Pamela, 'The Third Term is not always the Father : Women and/as the "Paternal Function" in Destry Rides Again', Enclitic, 5, no. 2 /6, no. 1 (1981/82), 55-65

- Flynn, Thomas R., 'The Role of the Image in Sartre's Aesthetic', Journal of Aesthetics and Art Criticism, XXXIII, no. 4 (1975), 431-442
- Foucault, Michel, 'Politics and the study of discourse', Ideology and Consciousness, 3 (1978), 7-26
- Freud, Sigmund, 'A Case of Paranoia Running Counter to the Psychoanalytic Theory of the Disease', in Standard Edition, Volume XIV (1957), 263-272
- , 'The Neuro-Psychoses of Defence : (III) A Case of Chronic Paranoia', in Standard Edition of the Complete Psychological Works, ed. by James Strachey, Volume III (1962), 174-185
- , The Interpretation of Dreams, Pelican Freud Library, Volume 4, ed. by Angela Richards (Harmondsworth, 1976)
- , Jokes and their Relation to the Unconscious, Pelican Freud Library, Volume 6, ed. by Angela Richards (Harmondsworth, 1976)
- , 'Psychoanalytic Notes on an Autobiographical Account of a Case of Paranoia (Dementia Paranoides), (Schreber)', in Case Histories II, Pelican Freud Library, Volume 9, ed. by Angela Richards (Harmondsworth, 1979), 138-223
- Gallop, Jane, Feminism and Psychoanalysis : The Daughter's Seduction (London, 1982)
- Giddens, Anthony, Central Problems in Social Theory : Action, structure and contradiction in social analysis (London, 1979)
- Giner, Salvador, Mass Society (London, 1976)
- Gledhill, Christine, 'Klute, Part 1 : A contemporary film noir and feminist criticism. Part 2 : Feminism and Klute', in Women In Film Noir, ed. by E. Ann Kaplan (London, 1978), 6-21, 112-128
- Gorz, André, 'Sartre and Marx', in Western Marxism : A Critical Reader, ed. by New Left Review (London, 1978), 176-200
- Grant, Barry K., ed., Film Genre : Theory and Criticism (Metuchen, N.J., 1977)
- Green, Bryan S., Knowing the Poor : A Case-Study in Textual Reality Construction, (London, 1983)
- Greimas, A. Julien, 'The Interpretation of Myth : Theory and Practice', in Structural Analysis of Oral Tradition, ed. by Pierre Maranda and Elli Kóngas Maranda (Philadelphia, 1971), 81-121
- Habermas, Jürgen, Legitimation Crisis (London, 1976)
- Hall, Stuart, 'Culture, the Media and the "Ideological Effect"', in Mass Communication and Society, ed. by James Curran and others (London, 1977), 315-348

- Hall, Stuart, 'The Problem of Ideology - Marxism without guarantees', in Marx : A Hundred Years On, ed. by Betty Matthews (London, 1983), 57-85
- Halpern, Joseph, 'Sartre's Enclosed Spaces', Yale French Studies, 57 (1979), 58-71
- Hampshire, Stuart, Spinoza (Harmondsworth, 1962)
- Harvey, Stephen, 'Another Man's Method', American Film, VIII, no. 7 (1983), 34-36, 67-69
- Harvey, Sylvia, May '68 and Film Culture (London, 1978)
- Hayim, Gila J., The Existential Sociology of Jean-Paul Sartre (Amherst, 1980)
- Heath, Stephen, 'Film and System : Terms of Analysis', Screen, 16, no. 1 (1975), 7-77 (Part I); 16, no. 2 (1975), 91-113 (Part II)
- , 'Screen Images, Film Memory', Edinburgh '76 Magazine (1976), 33-42
- , 'Difference', Screen, 19, no. 3 (1978), 51-112
- , 'The Turn of the Subject', Cine-Tracts, 2, nos. 3/4 (1979), 32-48
- Held, David, Introduction to Critical Theory : Horkheimer to Habermas (London, 1980)
- Henderson, Brian, A Critique of Film Theory (New York, 1980)
- Hendin, Josephine, Vulnerable People : A View of American Fiction Since 1945 (New York, 1978)
- Hendricks, William O., 'The Structural Study of Narration : Sample Analyses', Poetics, 3 (1972), 100-123
- Hernton, Calvin C., Sex and Racism (London, 1970)
- Hirsh, Arthur, The French New Left : An Intellectual History From Sartre to Gorz (Boston, 1981)
- Hirst, Paul, On Law and Ideology (London, 1979)
- Hocquenghem, Guy, 'Family, Capitalism, Anus', Semiotext(e), II, no. 3 (1977), 149-158
- Horowitz, Irving Louis, Ideology and Utopia in the United States 1956-1976 (New York, 1977)
- , 'On Relieving the Deformities of Our Transgressions', Society, 16, no. 5 (1979), 80-83
- Howard, Dick, The Marxian Legacy (London, 1977)
- Hugo, Chris, 'American Cinema in the '70s : The Economic Background', Movie, 27/28 (1980/81), 43-49

- Humphries, Reynold, 'The Function of Mexico in Peckinpah's Films',
Jump Cut, 18 (1978), 17-20
- Hurd, Geoffrey, 'The Television Presentation of the Police', in
Popular Television and Film, ed. by Tony Bennett and others
(London, 1981), 53-70
- Hymer, Stephen H., 'International politics and international economics :
a radical approach', in The Multinational Corporation : A Radical
Approach, ed. by Robert B. Cohen and others (Cambridge, 1979),
256-272
- Illich, Ivan, Gender (London, 1983)
- Jacobs, Diane, Hollywood Renaissance (Cranbury, New Jersey, 1977)
- Jameson, Fredric, The Prison-House of Language : A Critical Account
of Structuralism and Russian Formalism (Princeton, 1972)
- , 'Three Methods in Sartre's Literary Criticism', in Modern French
Criticism : From Proust and Valery to Structuralism, ed. by John K. Simon
(Chicago, 1972), 193-227
- , 'Ideology, Narrative Analysis and Popular Culture', Theory and
Society, 4, no. 4 (1977), 543-559
- , 'Marxism and Historicism', New Literary History, XI, no. 1 (1979),
41-73
- , 'From Criticism to History', New Literary History, XII, no. 2
(1981), 367-375
- , 'Reading Hitchcock', October, 23 (1982), 15-42
- , 'Pleasure : A Political Issue', in Formations of Pleasure, ed.
by Formations Editorial Board (London, 1983), 1-14
- Jefferson, Ann, 'Structuralism and post-structuralism', in Modern Literary
Theory : A Comparative Introduction, ed. by Ann Jefferson and David
Robey (London, 1982), 84-112
- Jenkins, Bruce, 'Structures of Perceptual Engagement in Film : Toward a
Technology of Embodiment', Film Reader, 2 (1977), 141-146
- Johnson, Barbara, 'The Frame of Reference : Poe, Lacan, Derrida', Yale
French Studies, 55/56 (1977), 457-505
- Johnston, Sheila, 'The Author as Public Institution : The "New" Cinema
in the Federal Republic of Germany', Screen Education, 32/33 (1979/80),
67-78
- Kerr, Paul, 'Watching the Detectives', Primetime, 1, no. 1 (1981), 2-6
- Kolker, Robert Phillip, A Cinema of Loneliness (New York, 1980)

- Kress, G.R., 'Structuralism and Popular Culture', in Approaches to Popular Culture, ed. by C.W.E. Bigsby (London, 1976), 85-106
- Krieger, Murray, 'Mediation, Language, and Vision in the Reading of Literature', in Interpretation: Theory and Practice, ed. by Charles S. Singleton (Baltimore, 1969), 211-242
- Kristeva, Julia, 'Signifying Practice and Mode of Production', Edinburgh '76 Magazine (1976), 64-76
- , 'Gesture : Practice or communication?', in Social Aspects of the Human Body : A Reader of Key Texts, ed. by Ted P olhemus (Harmondsworth, 1978), 264-284
- Kuhn, Annette, 'The Big Sleep : A Disturbance in the Sphere of Sexuality', Wide Angle, 4, no. 3 (1980), 4-11
- , Women's pictures : Feminism and cinema (London, 1982)
- Kuntzel, Thierry, 'The Treatment of Ideology in the Textual Analysis of Film', Screen Reader 2 (1981), 187-197 (orig. Screen, 14, no. 3)
- Lacan, Jacques, 'Seminar on The Purloined Letter', Yale French Studies, 48 (1972), 38-72
- , 'The mirror stage as formative of the function of the I', in Écrits : A selection, translated by Alan Sheridan (London, 1977), 1-7
- , The Four Fundamental Concepts of Psycho-Analysis (Harmondsworth, 1979)
- , 'God and the Jouissance of The Woman', and 'A Love Letter', in Feminine Sexuality, ed. by Juliet Mitchell and Jacqueline Rose (London, 1982), 137-161
- Larraine, Jorge, The Concept of Ideology (London, 1979)
- Lasch, Christopher, The Culture of Narcissism : American Life in an Age of Diminishing Expectations (London, 1980)
- Leach, Edmund, 'Vico and ¹Levi-Strauss on the Origins of Humanity', in Giambattista Vico : An International Symposium, ed. by Giorgio Tagliacozzo (Baltimore, 1969), 309-318
- Lederman, Marie Jean, 'Superman, Oedipus and the Myth of the Birth of the Hero', Journal of Popular Film and Television, VII, no. 3 (1979), 235-245
- Lefebvre, Henri, Everyday Life in the Modern World (Harmondsworth, 1971)
- Lentricchia, Frank, After the New Criticism (London, 1983)
- ¹Levi-Strauss, Claude, Tristes Tropiques (Harmondsworth, 1976)
- ¹Lévy, Benny, 'Today's Hope : Conversations with Sartre', Telos, 44 (1980), 155-181

- Linderman, Deborah, 'Oedipus in Chinatown', Enclitic, 5, no. 2 /6, no. 1 (1981/82), 190-203
- Locke, John, An Essay Concerning Human Understanding (London, 1880)
- Lotman, Jurij, Semiotics of Cinema, Michigan Slavic Contributions, no. 5 (Ann Arbor, 1976)
- Lukes, Stephen, Individualism (Oxford, 1973)
- Lyotard, Jean-François, 'Energumen Capitalism', Semiotext(e), II, no. 3 (1977), 11-26
- , 'The Dream - Work Does Not Think', Oxford Literary Review, 6, no. 1 (1983), 3-34
- McGilligan, Patrick, Cagney : The Actor As Auteur (New York : Da Capo republication, 1979)
- McGuigan, Jim, 'The Literary Sociology of Sartre', in The Sociology of Literature : Theoretical Approaches, Sociological Review Monograph 25, ed. by Jane Routh and Janet Wolff (1977), 163-180
- MacCabe, Colin, 'The discursive and the ideological in film : Notes on the conditions of political intervention', Screen, 19, no. 4 (1978/9), 29-43
- , 'On discourse', Economy and Society, 8, no. 4 (1979), 279-307
- Macpherson, C.B., The Political Theory of Possessive Individualism : Hobbes to Locke (Oxford, 1962)
- Macey, David, 'Fragments of an Analysis : Lacan in Context', Radical Philosophy, 35 (1983), 1-9
- Marcuse, Herbert, 'The Concept of Essence', in Negations : Essays in Critical Theory (London, 1968), 43-87
- Margolin, Uri, 'Conclusion : Literary Structuralism and Hermeneutics in Significant Convergence, 1976' in Interpretation of Narrative, ed. by Mario J. Valdés and Owen J. Miller (Toronto, 1978), 177-185
- Marx, Karl, Selected Writings in Sociology and Social Philosophy, second edition, ed. by T.B. Bottomore and Maximilien Rubel (Harmondsworth, 1963)
- , and Frederick Engels, On Literature and Art : a selection of writings, ed. by Lee Baxandall and Stefan Morawski (New York, 1973)
- Merquior, J.G., The Veil and the Mask : Essays on culture and ideology (London, 1979)
- Merrell, Floyd, 'Communication and Paradox in Carlos Fuentes' The Death of Artemio Cruz : Toward a Semiotics of Character', Semiotica, 18, no. 4 (1976), 339-360

- Milne, Tom, Review of Hustle, Monthly Film Bulletin, 43, no. 506
(March, 1976), 53-54
- Mitchell, Juliet, Psychoanalysis and Feminism (Harmondsworth, 1975)
- Molina, Victor, 'Notes on Marx and the Problem of Individuality', in
On Ideology, ed. by an editorial group at the Centre for Contemporary
Cultural Studies, University of Birmingham (London, 1977), 230-258
- Morley, Dave, 'Texts, readers, subjects', in Culture, Media, Language :
Working Papers in Cultural Studies, 1972-79, ed. by Stuart Hall and
others (London, 1980), 163-173 (notes and references, 295-297)
- Mulvey, Laura, 'Visual Pleasure and Narrative Cinema', Screen, 16, no. 3
(1975), 6-18
- , 'Afterthoughts ... inspired by Duel In The Sun', Framework,
15/16/17 (1981), 12-15
- Neal, Stephen, Genre (London, 1980)
- , 'Hollywood Strikes Back : Special Effects in Recent American
Cinema', Screen, 21, no. 3 (1980), 101-105
- Nichols, Bill, Ideology and the Image : Social Representation in the
Cinema and Other Media (Bloomington, 1981)
- Nolt, John, 'Expression and Emotion', British Journal of Aesthetics,
21, no. 2 (1981), 139-150
- Nowell Smith, Geoffrey, 'The Question of Hegemony', Radical Philosophy,
5 (1973), 23-25
- O'Neill, John, 'Gay Technology and the Body Politic', in The Body as a
Medium of Expression, ed. by Jonathan Benthall and Ted Polhemus
(London, 1975), 291-302
- , 'Critique and Remembrance', in On Critical Theory, edited by
John O'Neill (New York, 1976), 1-11
- Paci, Enzo, 'Vico, Structuralism, and the Phenomenological Encyclopedia
of the Sciences', in Giambattista Vico : An International Symposium,
ed. by Giorgio Tagliacozzo (Baltimore, 1969), 497-315
- ^
Pêcheux, Michel, Language, Semantics and Ideology : Stating the Obvious
(London, 1982)
- Perkins, T.E., 'Rethinking Stereotypes', in Ideology and Cultural
Production, ed. by Michèle Barrett and others (London, 1979), 135-159
- Pettit, Arthur G., 'The Wild Bunch (1969)', in Western Movies, ed. by
William T. Pilkington and Don Graham (Albuquerque, New Mexico, 1979),
97-107
- Poulet, Georges, 'Criticism and the Experience of Interiority', in Reader-
Response Criticism : From Formalism to Post-Structuralism, ed. by Jane
P. Tompkins (Baltimore, 1980), 41-49

- Pudovkin, V.I., 'Film Acting', in Film Technique and Film Acting, memorial edition, ed. by Ivor Montagu (London, 1958), 221-371
- Requena, Jesus G., 'Narrativity/Discursivity In the American Television Film', Screen, 22, no. 4 (1981), 38-42
- Ricoeur, Paul, 'Hermeneutics : Restoration of Meaning or Reduc tion of Illusion?', in Critical Sociology : Selected Readings, ed. by Paul Connerton (Harmondsworth, 1976), 194-203
- Robey, David, Structuralism : an introduction (Oxford, 1973)
- Roiphe, Anne, 'Ma and Pa and John-Boy in Mythic America : The Waltons', in Television : The Critical View, ed. by Horace Newcomb (New York, 1979), 8-15
- Rorty, Richard, Philosophy and the Mirror of Nature (Oxford, 1980)
- Rose, Jacqueline, 'The Cinematic Apparatus : Problems in Current Theory', in The Cinematic Apparatus, ed. by Teresa de Lauretis and Stephen Heath (London, 1980), 172-186
- Rossi-Landi, Ferruccio, 'Sign systems and social reproduction', Ideology and Consciousness, 3 (1978), 49-65
- Rustin, Michael, 'Kleinian Psychoanalysis and the Theory of Culture', in The Politics of Theory : Proceedings of the Essex conference on the Sociology of Literature July 1982, ed. by Francis Barker and others (Colchester, 1983), 57-70
- Said, Edward W., 'The Text, the World, the Critic', in Textual Strategies : Perspectives in Post-Structuralist Criticism, ed. with an Introduction, by Josué V. Harari (London, 1980), 161-188
- Saussure, Ferdinand de, Course in General Linguistics, revised edition with an Introduction by Jonathan Culler (London, 1974)
- Schatz, Thomas, Hollywood Genres : Formulas, Filmmaking, and the Studio System (New York, 1981)
- Scholes, Robert, Structuralism in Literature : An Introduction (New Haven, 1974)
- Segal, Hanna, Klein (Glasgow, 1979)
- Shadoian, Jack, Dreams and Dead Ends : The American Gangster/Crime Film (Cambridge, Mass., 1977)
- Sharratt, Bernard, 'The politics of the popular? - from melodrama to television', in Performance and politics in popular drama : Aspects of popular entertainment in theatre, film and television 1800-1976, ed. by David Bradby, Louis James and Bernard Sharratt (Cambridge, 1980), 275-295
- Sheridan, Alan, Michel Foucault : The Will to Truth (London, 1980)
- Shukman, Ann, and L.M. O'Toole, eds., 'A Contextual Glossary of Formalist Terminology', Russian Poetics in Translation, 4 (1977), 13-48

- Siemińska, Ewa, 'Connotation and Denotation in a Work of Film Art', in Sign, Language, Culture, ed. by A.J. Greimas and others (The Hague, 1970), 414-422
- Silver, Alain, and Elizabeth Ward, Robert Aldrich : a guide to references and resources (Boston, Mass., 1979)
- Silver, Isidore, 'Police as Folk Heroes', Society, 9, no. 7 (1972), 45-46
- Smart, Barry, Sociology, phenomenology and Marxian analysis : A critical discussion of the theory and practice of a science of society (London, 1976)
- Solomon, Stanley, J., Beyond Formula : American Film Genres (New York, 1976)
- Squadrito, Kathy, 'Locke's View of Essence and Its Relation to Racism : A Reply to Professor Bracken', Locke Newsletter, 6 (1975), 41-54
- Stecker, Robert, 'Nolt on Expression and Emotion', British Journal of Aesthetics, 23, no. 3 (1983), 234-239
- Thompson, E.P., 'The Poverty of Theory : or an Orrery of Errors' in The Poverty of Theory and other essays (London, 1978), 193-397
- Thomson, David, 'The Look on an Actor's Face', Sight and Sound, 46, no. 4 (1977), 240-244
- , America In the Dark : Hollywood and the Gift of Unreality (London, 1978)
- , 'In a Lonely Place', Sight and Sound, 48, no. 4 (1979), 215-220
- , 'The Director As Raging Bull : Why Can't a Woman Be More Like a Photographer?', Film Comment, 17, no. 1 (1981), 9-15
- , 'The End of the American Hero', Film Comment, 17, no. 4 (1981), 13-17
- Timpanaro, Sebastiano, The Freudian Slip : Psychoanalysis and Textual Criticism (London, 1976)
- Tompkins, Jane P., 'The Reader in History : The Changing Shape of Literary Response', in Reader-Response Criticism : From Formalism to Post-Structuralism, ed. by Jane P. Tompkins (Baltimore, 1980), 201-232
- Tucker, D.F.B., Marxism and Individualism (Oxford, 1980)
- Ungar, Steven, 'Doing And Not Doing Things With Barthes', Enclitic, II, no. 2 (1978), 86-109
- Vázquez, Adolfo Sánchez, The Philosophy of Praxis (London, 1977)
- Voloshinov, V.N. [M.M. Bakhtin], 'Discourse in Life and Discourse in Poetry', Russian Poetics in Translation, 10 (1983), 5-30

- Walker, Richard A., 'A theory of suburbanization : capitalism and the construction of urban space in the United States', in Urbanization and Urban Planning in Capitalist Society, ed. by Michael Dear and Allen J. Scott (London, 1981), 383-429
- Warnock, Mary, 'Historical Explanation in The Critique of Dialectical Reason', in Marx and Marxisms, Royal Institute of Philosophy Lecture Series : 14, ed. by G.H.R. Parkinson (Cambridge, 1982), 97-108
- Wellmer, Albrecht, 'Communications and Emancipation : Reflections on the Linguistic Turn in Critical Theory', in On Critical Theory, edited by John O'Neill (New York, 1976), 231-263
- Wilden, Anthony, System and Structure : Essays in Communication and Exchange, second edition (London, 1980)
- Willemsen, Paul, 'Voyeurism, the Look and Dwoskin', Afterimage, 6 (1976), 40-50
- , 'Notes on Subjectivity', Screen, 19, no. 1 (1978), 41-69
- Williams, Raymond, 'Base and superstructure in Marxist cultural theory', in Schooling and Capitalism : A sociological reader, ed. by Roger Dale and others (London, 1976), 202-210
- , Culture (Glasgow, 1981)
- Wisse, Ruth R., The Schlemiel as Modern Hero (Chicago, 1971)
- Wolfe, Alan, 'Sociology, Liberalism, and the Radical Right', New Left Review, 128 (1981), 3-27
- Wolff, Janet, The Social Production of Art (London, 1981)
- Wollen, Peter, 'The Hermeneutic Code', in Readings and Writings : Semiotic Counter-Strategies (London, 1982), 40-48
- Wood, Michael, 'The Impatience of Harry', New Society, 67, no. 1106 (2 Feb. 1984), 166-167
- Wood, Robin, Personal Views : Explorations in Film (London, 1976)
- , 'The Incoherent Text : Narrative in the '70s', Movie, 27/28 (1980/81), 24-42
- Woollacott, Janet, 'Messages and meanings', in Culture, Society and the Media, ed. by Michael Gurevitch and others (London, 1982), 91-111
- Worth, Sol, 'The Development of a Semiotic of Film', Semiotica, 1, no. 3 (1969), 282-321
- Wright, Will, 'The sun sinks slowly on the western', New Society, 6 May 1976, pp. 292-294
- Zheutlin, Barbara, and David Talbot, Creative Differences : Profiles of Hollywood Dissidents (Boston, 1978)
- Ziegler, Robert E., 'Memory-spaces : Themes of the House and the Mountain in The Waltons', Journal of Popular Culture, 15, no. 3 (1981), 104-111

I say:
'Release me from the obligation
of this prologue ... '

Fernando Birri