

D4997/74

Thesis number.

Space.

THE PHYSIOLOGY OF CIRCULATION DURING SWIMMING  
ACTIVITY IN RAINBOW TROUT

by

I.G. Priede, B.Sc. (Wales)

Thesis submitted for the degree of  
Doctor of Philosophy  
in the  
University of Stirling.

October 1973

D4997/74

Thesis number

Space

ADDENDA & ERRATA

Figure 8	Cardiac respiratory reflexes.	
" 9	Approach reflexes.	
" 23	Triangles 1.35(V/L).	
" 29	Magnification 7.5 x	
" 30	Magnification 47 x	
" 33	Magnification 7.0x	
" 34	Magnification 47 x	
" 44	Magnification 5.0 x	
" 45	Magnification 6.0 x	
" 46	Magnification 118 x	
" 47	Magnification 47 x	
" 48	Magnification 7.0 x	
" 49	Magnification 47 x	
" 50	Magnification 47 x	
" 51	Magnification 7.5 x	
" 52	Magnification 12 x	
" 53	Magnification 47 x	
" 54	Magnification 47 x	The main <u>structural</u> elements.....
" 55	Magnification 25 x	
" 62	X PHARYNGEAL	..... a series of <u>gan</u> glia are connected....

References page 119 insert;

PERKS, A.M. (1969). The Neurohypophysis. In Fish Physiology,  
(ed. W.S. Hoar & D.J. Randall) ~~xvixivxi33~~ vol II 111-205.  
New York: Academic Press.

Appendix III : PRIEDE, I.G. (1974).

D4997/74

Thesis number

Space

ADDENDUM

There are errors in this thesis which if corrected alter the conclusions which have been reached on certain points:-

Page 57

The calculation in the bottom half of the page should be:-

$$\begin{aligned} \text{Therefore the pressure in the cylinder} &= T/r \\ \text{Therefore} \quad \text{BP} &= \frac{156960}{30} \end{aligned}$$

$$\text{BP} = \underline{5232 \text{ dynes/cm.}}$$

$$\text{This is equivalent to } \frac{5.232 \times 10^3}{1.33 \times 10^3} = 3.9 \text{ mm Hg.}$$

Therefore the type of breakdown being considered is very likely to occur at elevated swimming speeds.

Page 66

equation (4)

$$\frac{\text{HR}_t - \text{HR} + \text{HR}_{\text{basal}}}{\text{HR}_{\text{basal}}} = \text{Specific O}_2 \text{ pulse}$$

This equation is incorrect and the values derived directly from this for specific O<sub>2</sub> pulse should be ignored

A. G. Riede.

SH 1

D4997/74

Thesis number.

Space.

Refilm P 42. Text of Fig 25

I would like to thank my supervisor, Professor J. D. ...  
holiday, for his sympathetic support of the work and  
Dr. J. Tyler for his advice and help. I thank my wife and  
to colleagues at Strickland especially Mr. J. D. ... and  
Mr. W. G. Nelson for their helpful discussions and help with

practice "there must be a systole and diastole  
in all inquiry; a man's mind must be  
continually expanding and shrinking  
between the whole human horizon and  
the horizon of an object-glass."

first heading machine, and Miss Margaret Kelly for typing the  
manuscript. Finally I am grateful to my parents for their  
support and interest during this work.

Dr. Lydgate in "Middlemarch"

by George Eliot.

D4997/74

Thesis number.

Space.

Refilm P 42. Text of Fig 25

ACKNOWLEDGEMENTS

I would like to thank my supervisor, Professor F.G.T. Holliday, for his enthusiastic support of this work and Dr. P. Tytler for his advice and help. Thanks are also due to colleagues at Stirling especially Mr. R.I.G. Morgan and Mr. M.G. McLeod for many helpful discussions and help over practical difficulties. Also I wish to thank: Mr. A.H. Young and Mr. B.E. Povey and the staff of Shared Technical Services at Stirling University who built some of the experimental apparatus and gave much useful technical advice, Mr. R. Vitols of Loughborough University for his help with the design of the fish bending machine, and Miss Margaret Keilt for typing the manuscript. Finally I am grateful to my parents for their support and interest during this work.

THE INTRODUCTION 21

EXPERIMENTAL PROCEDURE 22

THE FISH BENDING MACHINE 23

RESULTS 24

THE FISH BENDING MACHINE 25

EXPERIMENTS ON FISH BENDING 26

DISCUSSION 27

CONCLUSIONS 28

APPENDIX I: TECHNICAL DRAWINGS 29

APPENDIX II: CASTING TECHNIQUES 30

APPENDIX III: REFERENCES 31

SH 1

D4997/74

Thesis number.

Space.

Refilm P 42. Text of Fig 25

CONTENTS

	page
INTRODUCTION.	1
MATERIALS AND METHODS.	9
<u>Introduction.</u>	9
<u>The Fish.</u>	9
<u>The flume for swimming studies.</u>	10
DESIGN AND CONSTRUCTION	10
VELOCITY MEASUREMENT AND OPERATING CHARACTERISTICS	13
<u>Surgical procedures</u>	15
ANAESTHESIA	15
INSERTION OF ECG ELECTRODES	16
VAGOTOMY	16
<u>Procedure for measurement of heart rate during swimming in intact and vagotomised fish</u>	18
INTACT FISH	18
VAGOTOMISED FISH	19
<u>Measurement of heart rate and oxygen consumption</u>	19
THE RESPIROMETER	19
EXPERIMENTAL PROCEDURE	21
<u>The fish bending machine &amp; experiments on dorsal aorta function</u>	24
THE FISH BENDING MACHINE	24
EXPERIMENTS ON TROUT DORSAL AORTA PREPARATIONS	26
EXPERIMENTS ON DORSAL AORTA MODELS	28
<u>Anatomical and histological techniques</u>	29
BASIC ANATOMICAL TECHNIQUES	29
INJECTION AND CASTING TECHNIQUES	30
OSTEOLOGY	31

D4997/74

Thesis number

Space

Refilm P 42. Text of Fig 25

THICK SECTIONS	31
HISTOLOGY	32
ELASTICITY MEASUREMENT - DORSAL AORTA	
LIGAMENT	33
ELASTICITY MEASUREMENT - BULBUS ARTERIOSUS	33
RESULTS, OBSERVATIONS & ANALYSIS	35
<u>Swimming tests and heart rate measurements</u>	35
THE RELATIONSHIP BETWEEN SWIMMING SPEED & HEART RATE AT 6.5°C	35
<u>Intact fish</u>	35
<u>The effect of unilateral vagotomy</u>	37
<u>The effect of bilateral vagotomy</u>	38
THE RELATIONSHIP BETWEEN SWIMMING SPEED AND HEART RATE AT 15°C	39
<u>Intact fish</u>	39
<u>The effect of unilateral vagotomy</u>	40
<u>The effect of bilateral vagotomy</u>	40
CONCLUSIONS	41
<u>The effects of feeding on heart rate</u>	41
INTRODUCTION	41
THE EFFECT OF A FULL STOMACH	42
THE EFFECT OF STARVATION	42
ECG PHENOMENA DURING FEEDING	43
<u>Oxygen consumption and heart rate measurements</u>	44
<u>Auxiliary circulatory pumps - structure and function</u>	48
LYMPH PROPULSORS	48
DORSAL AORTA LIGAMENT	51
<u>Anatomy</u>	51
<u>Ligament elasticity</u>	52

<u>Analysis of the possible function of</u>	
<u>the dorsal aorta ligament</u>	53
<u>Experiments with the fish bending</u>	
<u>machine</u>	58
On the trout cadaver preparation	58
On the dorsal aorta model	59
<u>Heart structure</u>	60
SINUS VENOSUS	60
ATRIUM	60
VENTRICLE	61
BULBUS ARTERIOSUS	61
BULBUS ARTERIOSUS - VOLUME RELATIONS	63
DISCUSSION	64
<u>Heart rate in relation to metabolism</u>	64
THE EFFECT OF SWIMMING ACTIVITY	64
THE GENERAL RELATIONSHIP BETWEEN HEART RATE	
AND OXYGEN CONSUMPTION	67
EFFECT OF TEMPERATURE	73
EFFECT OF FEEDING AND STARVATION	74
<u>The role of the vagus nerve in control of</u>	
<u>cardiac function during activity</u>	77
INTRODUCTION	77
CHOLINERGIC INHIBITORY INNERVATION	77
EXCITATORY INNERVATION	81
AFFERENT SENSORY INNERVATION	84
STROKE VOLUME CONTROL	85
<u>Auxiliary pumps and their influence on</u>	
<u>circulation</u>	87
INTRODUCTION	87
LYMPH PROPULSORS	88



DORSAL AORTA LIGAMENT	90
CONCLUSIONS	94
<u>Functional morphology of the heart</u>	94
BULBUS ARTERIOSUS	94
VENTRICLE	100
ATRIUM	102
SINUS VENOSUS	102
<u>Conclusions</u>	103
REFERENCES	111
APPENDICES	

In British waters, rainbow trout for food is not on such a large scale but they form the basis of a considerable sport fishery. In Scotland and Northern England although rainbow trout catch levels are not generally high, the population is entirely dependent on restocking with hatchery raised fish, thus although living more or less wild in many British waters, this species is essentially an artificially managed resource upon which restocking and genetic selection (Donaldson and Olson 1987) are used as general fishery controls. A detailed understanding of the biology and physiology of this species is hence of particular importance.

The salmonids have long been of particular interest to comparative endocrinologists and physiologists by virtue of their primitive position in teleost evolution. In recent years interest in their physiology has expanded partly in response to specific management problems. For example, Fraser and his co-workers have carried extensive investigations on

## INTRODUCTION

Rainbow trout (Salmo gairdneri) were introduced into Europe from North America in the latter half of the last century. They can tolerate higher water temperatures and lower oxygen concentrations than the native brown trout (Salmo trutta). Rainbows grow faster than brown trout under similar conditions and are thus particularly attractive for artificial rearing methods. In Denmark there is a thriving rainbow trout farming industry producing about 9,000 metric tons annually which is largely exported for table use. (Mills 1971).

In Britain production of rainbow trout for food is not on such a large scale but they form the basis of a considerable sport fishery. In Scotland and Northern England although rainbow trout reach sexual maturity they do not generally breed so the population is entirely dependent on restocking with hatchery reared fish, thus although living more or less wild in many British waters, this species is essentially an artificially managed resource upon which man can impose genetic selection (Donaldson and Olson 1957) as well as normal fishery controls. A detailed understanding of the biology and physiology of this species is hence of particular importance.

The salmonids have long been of particular interest to comparative anatomists and physiologists by virtue of their primitive position in teleost evolution. In recent years interest in their physiology has expanded partly in response to specific management problems. For example Brett and his co-workers have carried extensive investigations on

oxygen consumption in the Pacific salmon (Onchorhynchus nerka) initially in order to predict the consequences of certain proposals for the construction of dams on salmon rivers in British Columbia (Brett & Glass 1973). There has been a corresponding expansion in interest in the physiology of circulation, artificially reared trout being readily available to laboratories. Mott (1957) commented on the fragmentary nature of information available on fish circulation, much of which was from isolated comparative studies. Since then much more data has become available which has been the subject of two recent reviews by Randall (1970) and Satchell (1971).

The aim of this study was to investigate some of the changes in circulation during swimming activity and to work towards an integrated understanding of the relative importance of various regulatory mechanisms involved. Swimming activity was chosen as it probably demands some of the most rapid adjustments in circulation that the animal is likely to undergo. Telemetric studies on trout movements in lochs (Young et al 1972, Holliday et al 1974) have indicated that sustained high swimming speeds are rare in trout and this directed these laboratory studies towards concentration on the events during short periods of swimming with long periods of rest in between.

A series of papers; Stevens & Randall (1967a), Stevens & Randall (1967b) and Randall, Holeyton & Stevens (1967) gave a very full account of respiratory and cardiovascular function in rainbow trout during swimming at moderate speeds. The fish were made to swim in a water tunnel during a test lasting 15 minutes at speeds of up to 51cm/sec (200g to 600g fish). During this short swimming test and the subsequent recovery period measurements were taken of: blood

pressure (in the dorsal aorta, ventral aorta and sub-intestinal vein), buccal cavity water pressure, tail beat frequency, oxygen partial pressures (in the water of the buccal and opercular cavities and in the blood of dorsal and ventral aortas), carbon dioxide partial pressures (in the blood of the dorsal and ventral aortas) and oxygen consumption. These results were aggregated from experiments on 89 fish at temperatures between 5°C and 12°C.

Blood pressures and heart rates rose during swimming but changes in gas partial pressures in water and blood afferent and efferent to the gills were remarkably small. The cardiac output was calculated by the Fick principle and it was shown that the increase during swimming was the result of a 15% increase in heart rate and a five-fold increase in stroke volume. Stevens & Randall (1967b) conclude: "Thus the increased rate of delivery of oxygen to the tissues was largely the result of large increases in stroke volume of the heart, with adjustments in breathing to maintain saturation of the blood in the face of increased blood flow through the gills during moderate exercise." The work for this thesis hence focused on factors which might influence cardiac output in relation to changes in oxygen consumption.

Figure 1 shows a diagram of the circulatory system and some of the associated control mechanisms which are likely to control cardiac output.

Blood leaves the heart along the ventral aorta and passes through the 4 gill arches on either side of the buccal cavity. In the gills the blood can either flow through the lamellae or through the filament (Richards & Fromm 1969). These authors showed that in rainbow trout lamellar flow was induced

by catecholamines which also reduced the overall gill resistance to flow. Acetylcholine diverted the flow into the filament so that gaseous exchange with the water was reduced and the gill resistance increased. Some of the oxygenated blood from the first gill arches flows through the pseudobranch and then to the cranium. Davis (1971) has shown that a chemoreceptor site in this flow monitoring arterial  $PO_2$  is probably important in the circulatory and ventilatory responses of rainbow trout. Laurent & Rouzeau (1972) have studied the pseudobranch in rainbow trout and have shown that there is an afferent and efferent innervation. They detected and quantified different kinds of activity in the afferent nerves in response to hydrostatic pressure,  $Na^+$  ions,  $PO_2$ , osmotic pressure and pH. There are also end bud receptors in the buccal cavity which may monitor the  $PO_2$  of the respiratory water flow. (De Kock 1963, Randall 1970).

From the efferent branchial arteries most of the blood flows into the anterior mesenteric artery and back along the dorsal aorta. Mott (1950) comments on the small cranial circulation in the eel. Along the anterior mesenteric artery the flows into the visceral circulation and is returned via hepatic veins to the sinus venosus (St Konair 1947).

Franz (1898) noted the presence of a ligament in the dorsal aorta of trout and salmon embryos. Burne (1909) suggested that this may be a 'blood pumping mechanism. The main detailed account of the anatomy of the circulatory system of rainbow trout was carried out by a group of Polish workers: Sikorawa (1947), Grodzinski (1947), Gorkiewicz (1947), St Konair (1947) and St Koziol (1947). These authors do not

mention the presence of a ligament in the dorsal aorta. De Kock & Symmons (1959) reviewed the rather sparse literature on this ligament in some teleosts and restated Burne's hypothesis of the pumping function of this structure.





The blood in the dorsal aorta flows out through segmental lateral branches largely to the body musculature. Segmental veins drain blood from the muscle into the kidney and thence to the posterior cardinal vein (Gorkiewicz 1947). Around the posterior cardinal veins there is some chromaffin tissue (Nandi 1962) which may be the source of secretion of increased levels of blood catecholamines during activity (Nakano & Tomlinson 1967).

In the visceral circulation, the general body circulation and the gills plasma almost certainly filters into the lymph system. Wardle (1971) has shown that the volume of lymph in plaice is much larger than that of the blood and considers that in fish small changes in the rate of formation or drainage of lymph could have large effects on the blood volume. Kampmeier (1969) reviews the literature on the anatomy of the lymph system and notes the presence of propulsive mechanisms such as the caudal lymph heart which may help drainage of lymph into the major veins.

Returning to consider the heart, 3 major regulatory pathways can be recognised:-

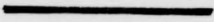
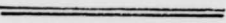
1. Neural Mechanisms. The inhibitory function of the vagus innervation of the fish heart is well established (Randall 1970). However in recent studies on the trout heart Gannon & Burnstock (1968) have demonstrated that the vagus can have excitatory as well as inhibitory effects. The excitation is mediated by adrenergic fibres in the vagus possibly originating

Figure 1. Schematic diagram of the main features of circulation in rainbow trout and the associated control pathways.

Blood -   
 lymph -   
 cholinergic innervation -   
 adrenergic innervation -   
 afferent innervation -   
 The "end bud" receptors are situated in the water flow in the buccal cavity.

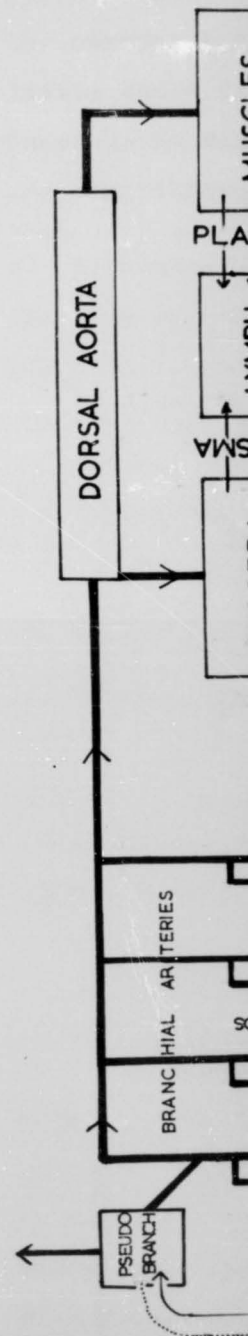





from the sympathetic ganglia. Laurent (1962) has demonstrated the function of afferent sensory elements in the cardiac branch of the vagus in catfish but Randall (1966) could find no similar function in goldfish and tench. There is no direct evidence on the presence or absence of afferent fibres in the cardiac nerve of trout.

2. Mechanical effects. Bennion (1968) has shown that increase in venous pressure in an in vitro trout heart preparation caused increases in cardiac output in accordance with Starling's law. Effects of peripheral vasodilation or the action of auxiliary pumps such as the lymph propulsors and possibly the dorsal aorta ligament may increase venous return and cause a reflex increase in cardiac output.

3. Endocrine effects. Increases in the levels of circulating catecholamines during activity can have a cardiac excitatory effect as well as influences elsewhere in the vascular system. Randall & Stevens (1967) could explain changes in blood pressure during exercise in salmon in terms of the interaction of adrenaline with  $\alpha$  adrenergic receptors.

In the present study investigations were directed with the following aims:-

1. The extension of knowledge of changes in heart rate to a full range of swimming speeds up to the maximum sustainable speed at two temperatures, 6.5°C and 15°C. Relating this to metabolic studies which have been carried out on trout (Webb 1970) estimates could be made of the relative importance of changes in heart rate in the transport of oxygen to the tissues.

2. The investigation of the role of the vagus nerve in cardiac regulation in vivo during swimming in the light of recent in vitro evidence of its dual excitatory and inhibitory function in trout.
3. The investigation of the structure and function of auxiliary circulatory pumps which may increase venous return during activity which in turn would increase cardiac output.
4. The elucidation of certain aspects of the anatomy of the heart which may be of significance in relation to the large stroke volume changes it seems to undergo.

A brief outline of the actual work carried out is given below:-

Electrocardiograms were measured during and after swimming at a wide range of speeds up to the maximum which could be sustained for 30 minutes. For each test the fish was made to swim at a uniform elevated velocity against a water flow for 30 minutes and heart rates were observed during this test and the subsequent recovery period at rest. 30 minutes was chosen as the test period as this is long enough for a respiratory "steady state" to be established as in previous metabolic studies on swimming fish (Brett 1964). The experiments were carried out at two temperatures  $6.5^{\circ}\text{C}$  and  $15^{\circ}\text{C}$  which coincide closely with the temperatures of Bennions (1968) studies on the heart and are likely to be found in winter and summer respectively.

Complementary to the swimming trials measurements were made of oxygen consumption and heart rate in fish at  $15^{\circ}\text{C}$ . With these experiments further detailed information was gained on the relationship between heart rate and metabolism.

The influence of the vagus nerve was investigated by cutting it in an experimental group of fish for comparison swimming trials with the intact fish. This procedure blocked both vagal cholinergic and adrenergic innervations to the heart.

The influence of auxiliary pumps which could increase venous return automatically during swimming was considered to be of particular interest. Anatomical studies were made of the lymph system, in particular the caudal lymph heart. Also anatomical studies were made of the dorsal aorta and its ligament and a theoretical analysis was made of any possible pumping activity. Experiments on the dorsal aorta function were carried out on a machine designed to reproduce swimming movements in trout cadavers.

The anatomy of the heart was investigated using standard histological techniques and by making casts of the chambers of the heart. Measurements were made of the pressure-volume relationships of the bulbus arteriosus and a rather more detailed account of the structure of this chamber was attempted in view of its importance in maintaining blood flow in the dorsal aorta (Randall 1970).

This work began with a consideration of the function of the whole fish and more particularly the interrelationships outlined in figure 1. The bulk of this thesis represents those components of that overall conception which developed into intrinsically coherent investigations. Nevertheless the underlying theme remains one of a general consideration of the function of the circulatory system in rainbow trout.

## MATERIALS AND METHODS

### Introduction

In the course of these studies considerable effort was directed to the design and development of special apparatus and techniques. Some of the problems raised merit discussion which would be inappropriate in the context of the final results. These points will be discussed in this section of the thesis which therefore needs to be longer than is customary for an account of materials and methods.

### The Fish

The fish used were rainbow trout (Salmo gairdneri) obtained from Howietoun fish farm at Bannockburn, Stirling. They were described by the farm as being of the "Shasta" race although it is doubtful if they can be regarded as being of a pure genetic strain (Mills 1971). Rainbow trout have been kept at this farm since their introduction into this country in the last century.

These fish were kept in the laboratory aquarium in 800 l circular tanks in which a circulation of water was maintained against which the fish would tend to swim. They were fed on standard floating fish pellets from Coopers Nutritional Products Ltd.

All the individuals used in the experiments were thus kept in the aquarium for at least 4 weeks at the proposed experimental temperature  $\pm 1^{\circ}\text{C}$ . The experimental fish were all 24.5 to 28.0cm long although for anatomical studies both

larger and smaller fish were used. No criteria of sex or sexual maturity were applied in choosing individuals for experimentation. It was ensured that the experimental fish were free of disease and in as good condition as possible.

#### The flume for swimming studies

##### DESIGN AND CONSTRUCTION.

In order to investigate changes occurring during swimming activity a fundamental requirement was a laboratory facility in which fish could be made to swim for periods at known velocities. Some sort of 'water treadmill' was envisaged in which fish would swim against a water movement so that wires and electrodes could be attached for physiological recording purposes with a minimal restriction to its swimming movements.

Particular limitations governed the design of the apparatus:-

1. A fish of about 25cm long was regarded as a minimum size on which surgical procedures could be satisfactorily carried out. The Home Office required that the diameter of any test chamber should be such that a fish could turn round without touching the sides. This defined the minimum size of the test chamber cross section as about 23cm.
2. Cost of the apparatus had to be kept to a minimum and no major engineering development could be contemplated.
3. A maximum swimming velocity of at least 60cm/sec was required to test fish over the full range of sustained swimming speeds.

Three main types of swimming apparatus have been used in previous swimming studies on fish:-

- (a) Fish Wheel: Described by Bainbridge and Brown (1958)

in which an annular channel containing water is rotated about its vertical axis. There is no movement of water relative to the walls of the chamber which has the advantage that no problems of non-uniformity of water flow are encountered as in other forms of apparatus. The cross section of the water space in Bainbridge's apparatus is 15cm by 19cm and yet it used a very large (5 H.P.) electric motor. To build a wheel with a 23 by 23cm cross section channel would have been a major engineering project and access to the fish with wires would have been difficult.

(b) Laminar flow flume: An example of this is that described by Arnold (1969). In this straight flume, water flows by gravity from a large header tank and falls freely over an adjustable weir at the other end. By varying the slope of the flume and the height of the weir different flow rates may be obtained. Even a scaled down version of this flume which is 30cm square in cross section would be a major undertaking to construct and large pumps are required to maintain the head of water in the supply tank. Although flow is uniform over most of the cross section of the channel, close to the walls flow is inevitably slower due to the boundary layer effect.

(c) Water Tunnel: Water tunnels have been constructed mainly as respirometers such as those used by Brett (1964) and Blaska et al (1960). The design principles involved are extensively reviewed by Bell and Terhune (1970). One of the advantages of these tunnels is that designs have been produced using small volumes of water which is necessary for respirometry. By inducing turbulent flow the boundary layer effect can be reduced and a uniform flow over a large proportion of the cross section of the tunnel can be obtained. However these

and other flow correcting devices involve a considerable head loss and relatively powerful pumps are required for quite small test chamber diameters. A tunnel of this type with a 23cm diameter chamber would again have been too expensive.

With all the above designs the provision for variation in drive motor speed over a wide range can be very expensive. It was also apparent that any pump capable of taking the full flow of water in a 23cm diameter cross section at 60cm/sec would have been very large and expensive (4 to 5 horsepower).

The main feature embodied in the design eventually used is in that the momentum of the circulating water is conserved by minimal obstruction to the flow. For this reason no flow correcting devices are incorporated and the grids confining the fish to the test chamber are of the largest mesh possible. This allows the use of a relatively small pump ( $\frac{3}{4}$  H.P.) in a bypass circuit to circulate the water. An open vaned centrifugal pump (Beresford Pumps Ltd.) was used, the output of which was constricted by a diaphragm valve which was used as a means of controlling the velocity of water in the main channel. A general diagram of the flume is shown in fig. 2 and a plan in fig. 3. Some non-uniformity in the flow pattern was felt to be acceptable in view of the advantages of this relatively simple design. The general pattern of a rectangular cross section channel is very similar to the apparatuses described by Heath & Pritchard (1962) and Oehmichen (1958). However both these designs are entirely enclosed and are therefore essentially water tunnels in their operating characteristics. In the type of open channel used in these studies with a free water surface no great

Figure 2. The flume used for swimming studies; diagram showing the general layout. The arrows indicate the direction of water flow.

PITOT TUBE

SWIVEL SUSPENSION

CABLE TO  
OSCILLOGRAPH



ming studies;  
eral layout.  
direction of

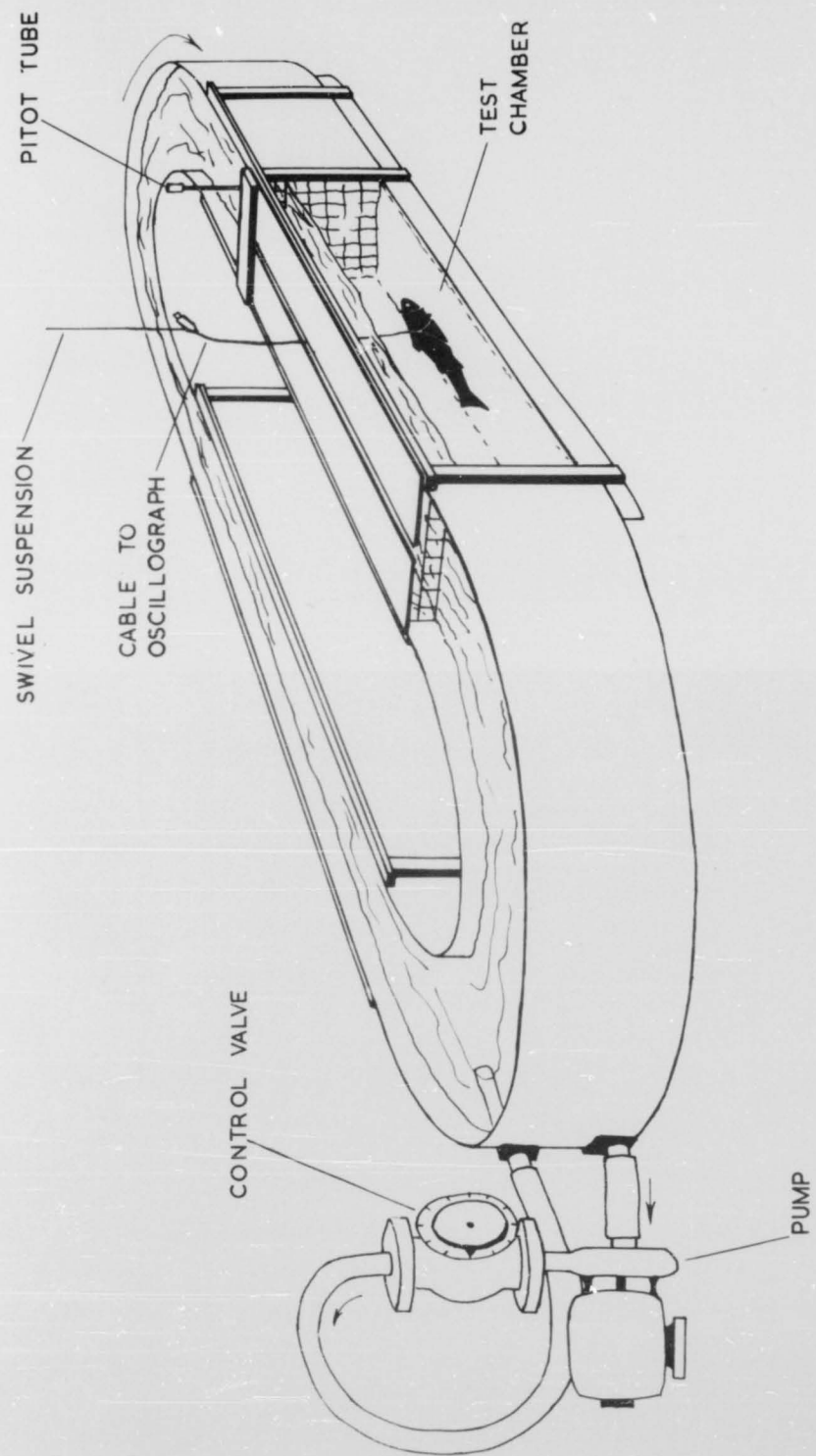
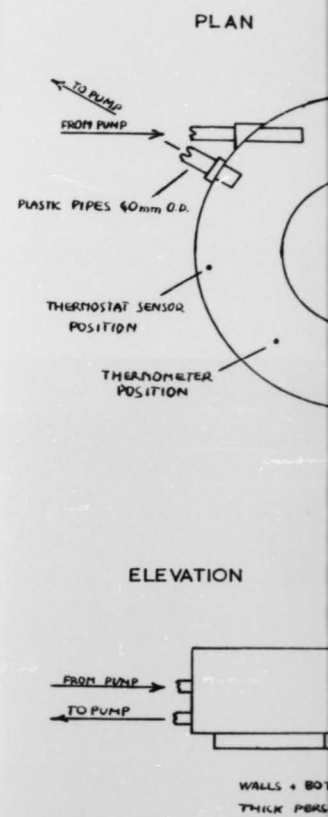
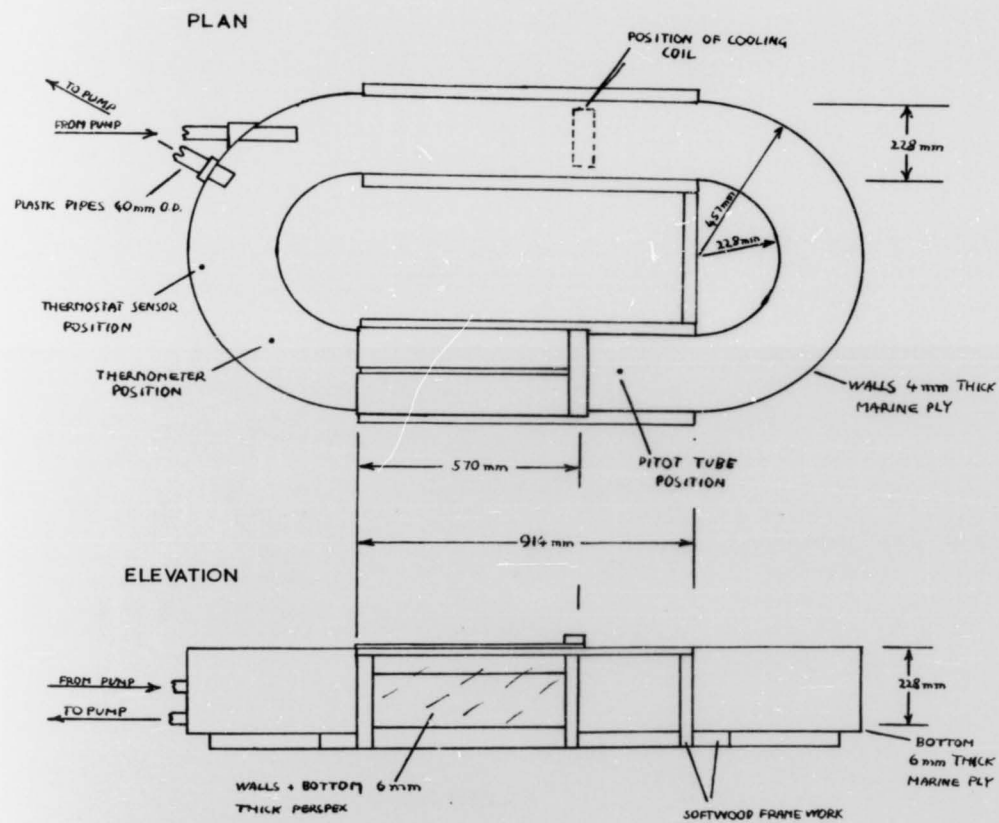

Figure 3. Plan and elevation drawings of the flume.



wings of the



S/T

Figure 4. The sloping water manometers used for velocity measurements front elevation. The assembly shown was mounted at the correct angle on a retort stand.

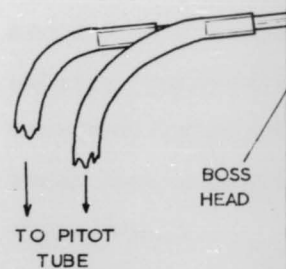

eters used  
s front  
y shown was  
ngle on a

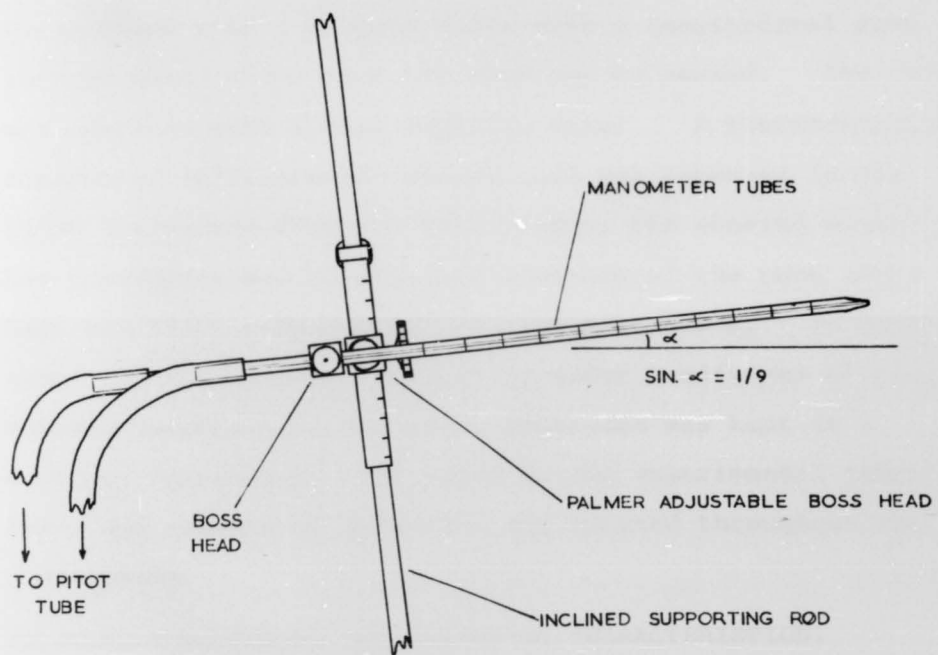

S/T

differences in the static head of water around the circuit can be allowed to occur.

The main channel is 23cm square in cross section and is constructed of timber and marine grade plywood painted to give a smooth waterproof finish. A 56cm long transparent perspex section is incorporated as a test chamber to which the fish is confined by 2.5cm mesh grids. The test chamber is provided with a plywood cover with a longitudinal slot through which wires from the fish may be passed. The flume was operated with a 21cm depth of water. A thermostatically controlled refrigerated cooling coil was immersed in the flume downstream from the pump output, the sensing element of the thermostat was placed just upstream of the pump input and kept the flume temperature constant to  $\pm 0.5^{\circ}\text{C}$ . In order to avoid the difficulties of cooling under conditions of high ambient temperatures the whole apparatus was kept in a constant temperature room close to the experimental temperature. Water was renewed at intervals and aerated throughout the experiments.

#### VELOCITY MEASUREMENT AND OPERATING CHARACTERISTICS.

A 3/16" diameter pitot-static tube (Airflow Developments Ltd.) was used for water velocity measurements in the flume. Dynamic and static pressures were measured using sloping water manometer. (fig. 4). 1ml graduated pipettes were used as manometer tubes and were chosen so that the smallest divisions on the scale (0.02ml) corresponded to 0.02cm in height when the tube was inclined at a slope of 1 in 9. The two tubes were mounted side by side on an adjustable boss head for ease of zero adjustment. The manometers were simply filled with water from the flume. Pressure could be read to an accuracy

of 0.01cm H<sub>2</sub>O. The water velocity was calculated using the formula:-

$$V = \sqrt{2gp} \quad (a)$$

V = velocity cm/sec

g = acceleration of gravity 981cm/sec<sup>2</sup>

p = dynamic pressure cm H<sub>2</sub>O

Then the error can be analysed according to Bell & Terhune (1970)

Differentiating:-

$$\frac{dV}{dp} = \frac{\sqrt{2g}}{2\sqrt{p}} \quad \text{or} \quad \frac{dV}{V} = \frac{dp}{2p} \quad (b)$$

As two menisci are involved in the determination of p the error in this measurement is  $\pm 0.02\text{cm H}_2\text{O}$ . However from (b) it can be seen that for a given error in velocity V the error in p can be twice as large.

The accuracy of the pitot tube velocity determination increases with velocity. For the manometer system used it can be calculated that the minimum velocity for 10% accuracy is 14.00cm/sec and the minimum velocity for 1% accuracy is 38.50cm/sec. Few swimming trials were carried out below 14.00cm/sec but in between trials the fish were allowed to rest at a velocity of approximately 5.0cm/sec. The control valve setting for this was determined by timing particles in the water flow passing across the length of the test chamber. The error in this calibration was  $\pm 1\text{cm/sec}$  due to slight variation in the behaviour of the valve diaphragm.

Figure 5. Water velocity profiles in the flume test chamber. Measurements were taken at the 3cm intervals indicated by the grid. The mean and standard deviations of these measurements at 3 speed settings are given. (Isometric projection.)

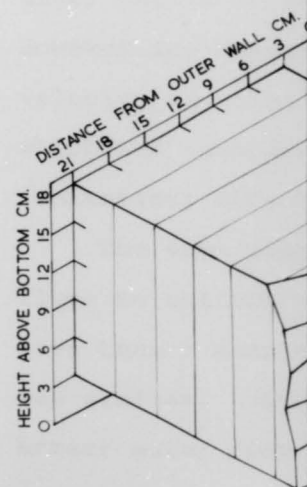
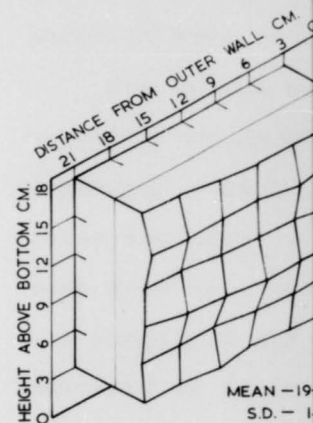



in the flume  
nts were taken  
icated by the  
ard deviations  
3 speed  
metric

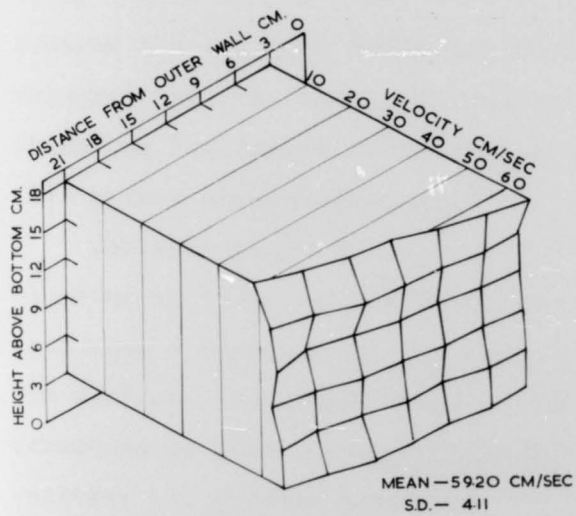
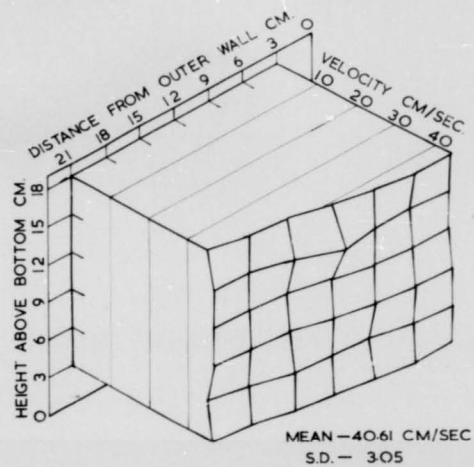
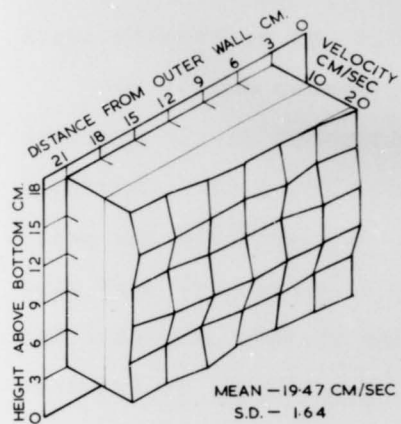

S/T

During a fish speed trial the pitot tube was immersed in the water flow as shown in the figures at a position where the velocities corresponded closely with those in the chamber. During such a trial pressure readings were taken at frequent intervals and the mean of these was used in calculation of the water velocity in order to minimise the influence of surge effects in the flow.

Due to the geometry of the flume some variation in velocity across the cross-section of the test chamber was expected. This was assessed by measuring the axial velocity using the pitot-static tube at points on an imaginary 3cm mesh grid in a plane tangential to the flow half way along the length of the chamber. Such velocity profiles were measured at three speed settings and are plotted isometrically in fig. 5. It was shown that the velocity of flow from the outer radius of the bends was higher than on the inside. However the standard deviation of the mean cross sectional velocity was less than 8.5% over a wide range of speeds which was considered acceptable in view of the design limitations already discussed.

The time taken for acceleration of the water in the flume to uniform maximum velocity for a speed trial was less than 3 minutes and the time for subsequent deceleration was similar. At high speeds a paddle was generally used to arrest water flow to facilitate precise determination of fish recovery times after exercise.

#### Surgical procedures

##### ANAESTHESIA.

For all surgical procedures fish were anaesthetised by immersion in 1:10000 solution of Tricaine methane sulphonate

Figure 6. The operating table used for vagotomy operations on trout. (isometric projection). The fish is held by a folded slab of foam rubber as if between the pages of a book. The arrows indicate how access can be gained under the operculum while the gills are perfused with anaesthetic solution. This fish holding device was placed on an operating table equipped with water drainage channels etc.

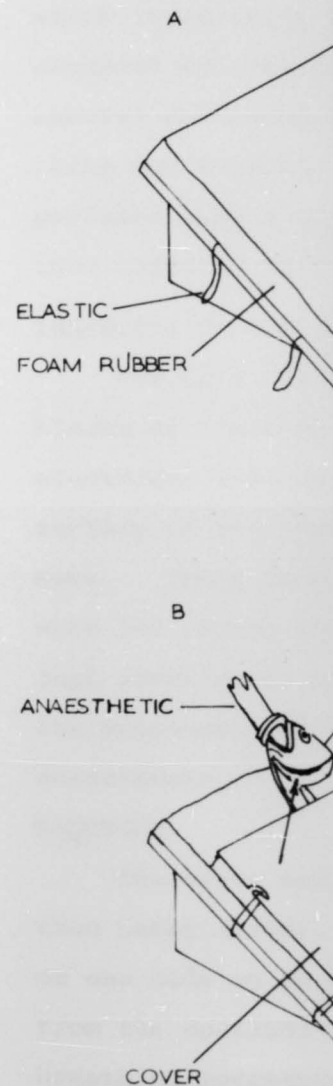

r vagotomy  
tric  
held by a  
as if between  
arrows  
ained under  
s are  
lution.  
placed on  
with water

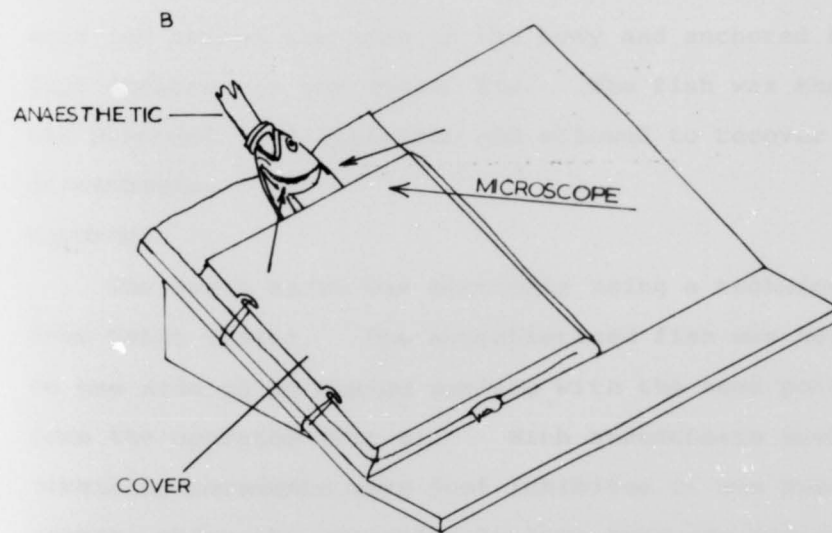
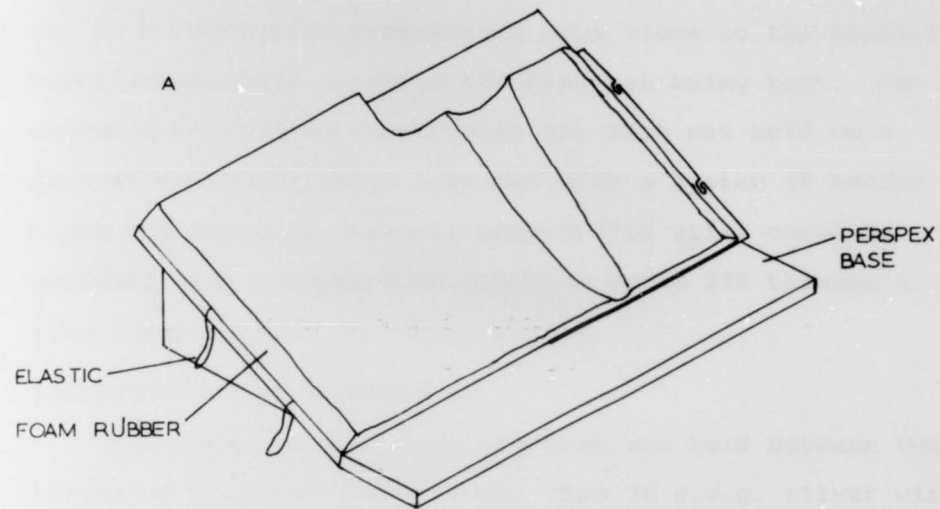

5/1

MS 222 (Sandoz). Care was taken to avoid temperature changes during anaesthesia and all operations were carried out in a controlled temperature room close to the prevailing water temperature in which the fish was being kept. For extended periods of anaesthesia the fish was held on a special operating table provided with a system of header tanks and drainage channels whereby the gills could be perfused with a controlled dilution of MS 222 through a tube inserted into the fish's mouth.

#### INSERTION OF ECG ELECTRODES.

For this the anaesthetised fish was held between two blocks of flexible rubber foam. Two 30 s.w.g. silver wire electrodes were implanted subcutaneously, one at the ventral surface of the pectoral girdle and the other anterior to the anus. These were sutured in place and the attached wires were led around the side of the body and anchored by suture just anterior to the dorsal fin. The fish was then put into the proposed test apparatus and allowed to recover from anaesthesia.

#### VAGOTOMY.

The vagus nerve was sectioned using a technique modified from Labat (1966). The anaesthetised fish was held lying on one side on an angled surface with the head pointing away from the operator (Fig 6). With anaesthesia such that the breathing movements were just inhibited it was possible to operate under the operculum looking from the posterior aspect with the aid of binocular dissection microscope.

A small incision about 5mm long was made posterior to the gills along the anterior edge of the cleithrum. A segment

Figure 7. Diagram of a dissection of rainbow trout to show the vagus nerve. The gills have been trimmed to give a clear view of the nerve.



rainbow trout  
The gills have  
view of the

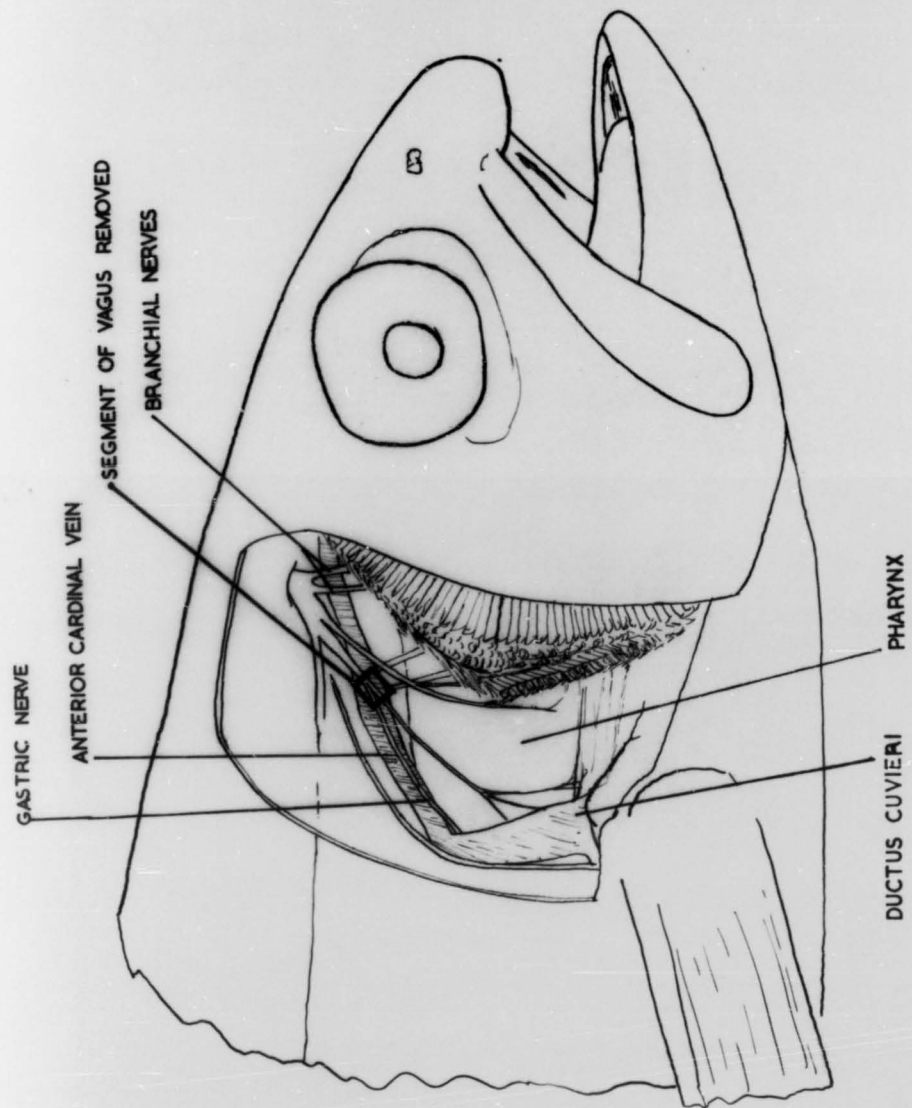

S/T

Figure 8. ECG s of a lightly anaesthetised rainbow trout at 15°C. The operculi were held shut during the times indicated by the horizontal bars. In the intact fish a cardiac inhibition is observed whereas in bivagotomised fish there is no response.

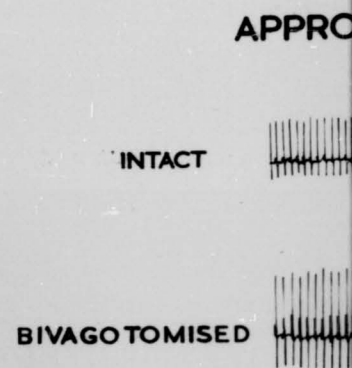



ised rainbow  
i were held  
ted by the  
tact fish a  
ed whereas  
is no

### APPROACH REFLEX

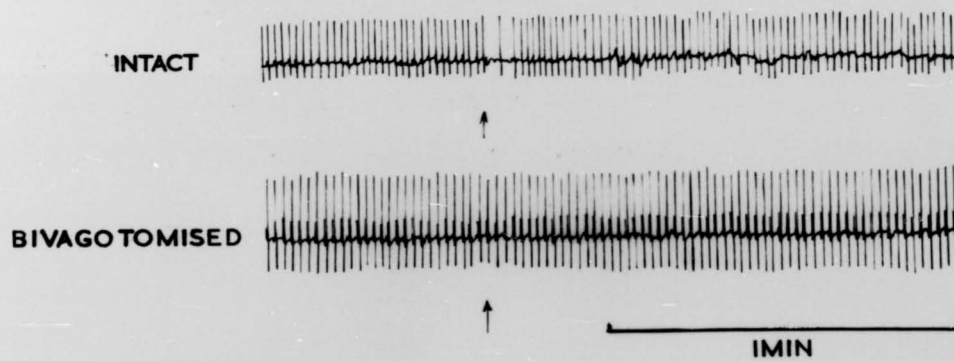

S/T

Figure 9. ECGs of intact and vagotomised fish at 6.5°C. The arrows indicate the presentation of a visual stimulus to the fish. In the intact fish a cardiac inhibitory reflex is observed.

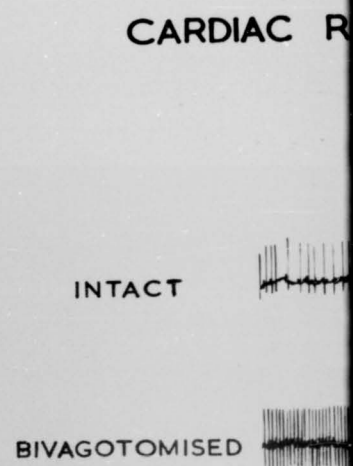

ed fish  
ate the  
mulus to  
sh a

## CARDIAC RESPIRATORY REFLEXES

LIGHT MS 222 ANAESTHESIA

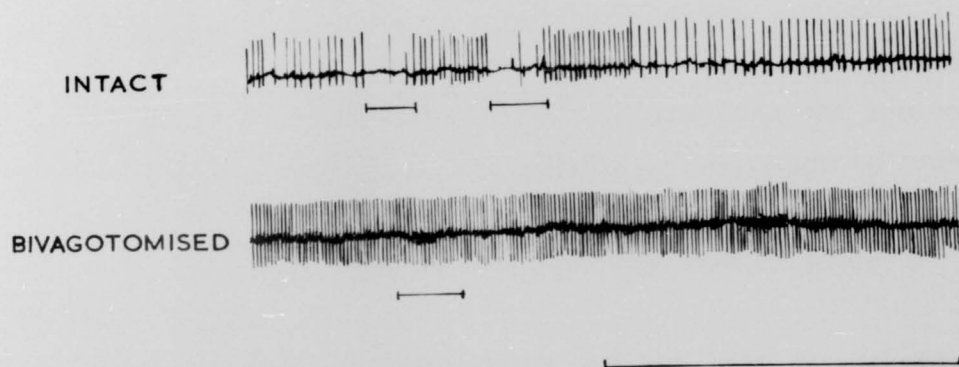

5/1

of the cardiovisceral branch of the vagus nerve was then readily exposed and was removed taking care not to cause haemorrhage of the major veins in this region (Fig. 7). Two sutures were used to close the wound. Approximately 35 minutes were required to effect a bilateral vagotomy whereupon the fish put into a 180l tank in which it was allowed to recover from anaesthesia. Within one hour the fish would regain its normal pale colour.

12 to 22 days were allowed in the recovery tank for healing of the wound. At 15°C the sutures were often shed within 5 days and wound healing was well advanced by the twelfth day. At 6.5°C up to 22 days were required for healing of the wounds.

In the course of subsequent experimentation the success of vagotomy and the absence of vagus regeneration were tested for in the lightly anaesthetised fish by checking for the absence of cardiac inhibitory reflexes when the operculi were held shut (fig 8). The absence of approach reflexes in the ECGs (Labat 1966) and post mortem anatomical examination provided additional verification of the lack of vagus function (fig 9).

In some fish the vagus nerve was cut only on one side, a sham operation being carried out on the other side. None of the fish which had been operated on could subsequently feed but there was no evidence of post-operative infection as reported by Labat (1966) and no mortalities occurred.

Procedure for measurement of heart rate  
during swimming in intact and vagotomised fish.

Tests consisting of the measurement of heart rates during swimming activity were carried out at two temperatures 6.5°C and 15°C. At each temperature 3 groups of fish were used:- intact, bilaterally vagotomised and unilaterally vagotomised.

INTACT FISH.

Feeding was discontinued 24 hours before implantation of ECG electrodes. The fish was then put into the test chamber of the flume to recover from the anaesthesia. The screened ECG cable 'tether' was passed through the slot in the test chamber cover and attached to a swivel suspended from the ceiling. The cable was broken at this point by a plug and socket which could be disconnected to allow complete freedom of movement for the fish when not recording ECGs. Electrocardiograms were recorded from the implanted electrodes using a Devices M2 heat pen recorder and an AC7C pre-amplifier. A screen round the test chamber prevented movements in the laboratory being seen by the fish and care was taken to avoid disturbance of the fish throughout the experiments.

The fish was kept in a water flow of about 5cm/sec in the test chamber against which it would orientate but not necessarily swim. It was thus allowed to rest overnight before the first speed trial. A speed trial consisted of exposure for 30 minutes to a uniform elevated water velocity against which the fish would swim in order to maintain station.

Two such trials were carried out daily with at least 3 hours rest (5cm/sec flow) in between. Trials were continued for up to 6 days with each animal at a wide range of velocities up to the maximum which could be sustained for 30 minutes. Heart rates were subsequently determined by counting the number of beats in each minute on the electrocardiogram.

In general at velocities which it could easily sustain the fish swam steadily throughout the 30 minutes without falling back or avoiding swimming by staying close to the inner wall of the flume. At velocities close to the maximum sustainable speed the fish tended to avoid swimming or rest its tail on the rear grid. Any trial in which the fish obviously was not swimming steadily at the test speed was excluded from the analysis of results. Tests were often also curtailed by breakage of the wires and connections to the electrodes.

#### VAGOTOMISED FISH.

Bilaterally and unilaterally vagotomised fish underwent exactly the same test procedure as the intact fish after the period of recovery from the vagotomy operation (12 - 22 days). While the fish was recovering from the anaesthesia for implantation of ECG electrodes, tests were carried out for cardiac inhibitory reflexes by holding the operculi shut. Absence of any cardiac response to this confirmed the absence of vagus function.

#### Measurement of heart rate and Oxygen Consumption

##### THE RESPIROMETER

The respirometer used in these experiments was a simple

Figure 10. The respirometer chamber used in heart rate and oxygen consumption measurements. (Isometric projection).

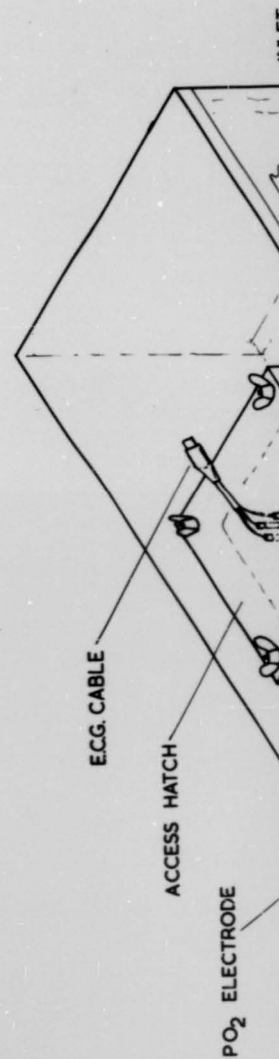

d in heart  
measurements.

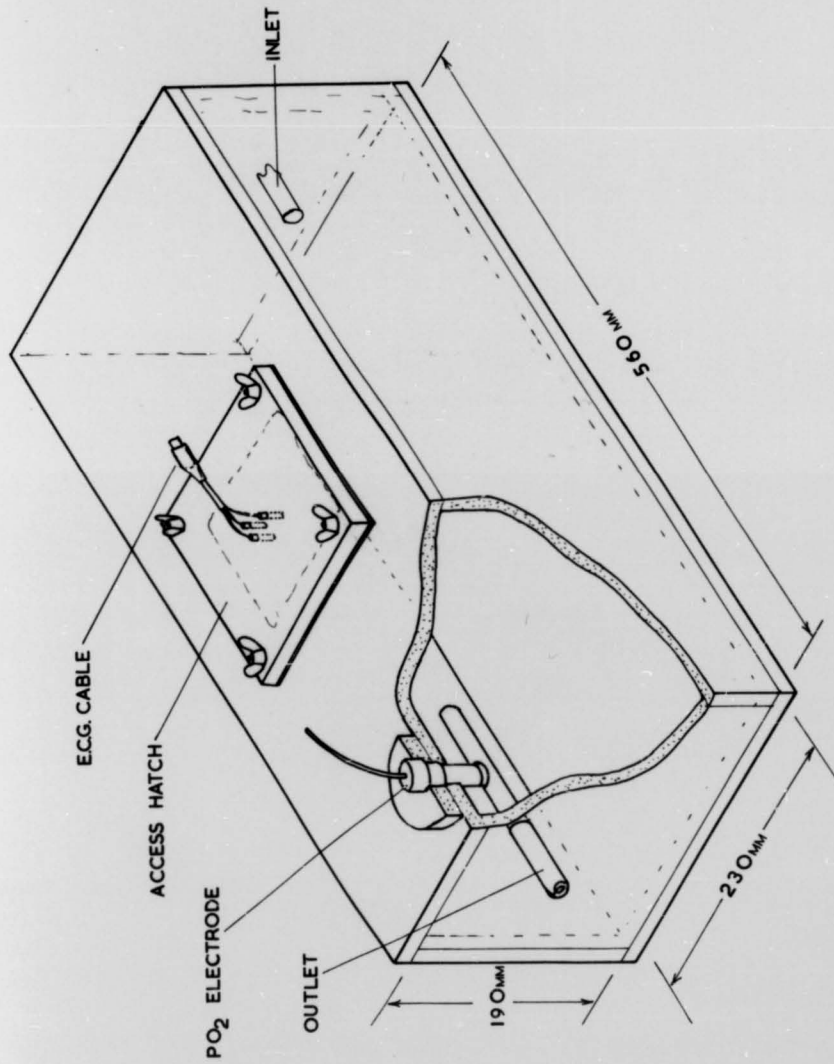

S/T



Figure 11. Schematic diagram of the water flow circuit used for the respirometer. (a) closed circuit; oxygen consumption being measured. (b) open circuit; system being flushed with fresh water.

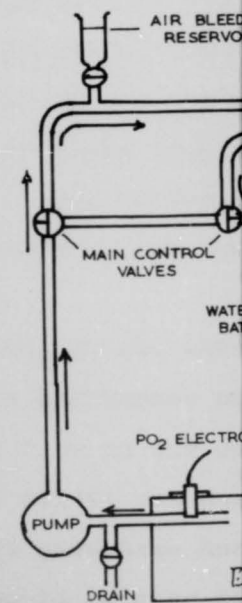
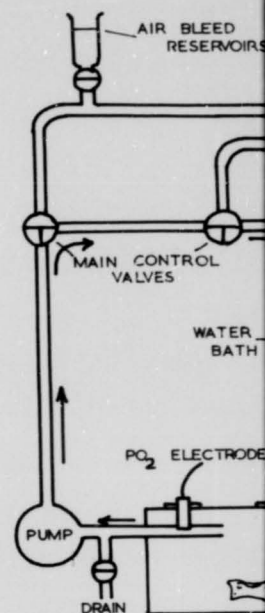

ter flow  
ometer.  
consumption  
rcuit;  
resh

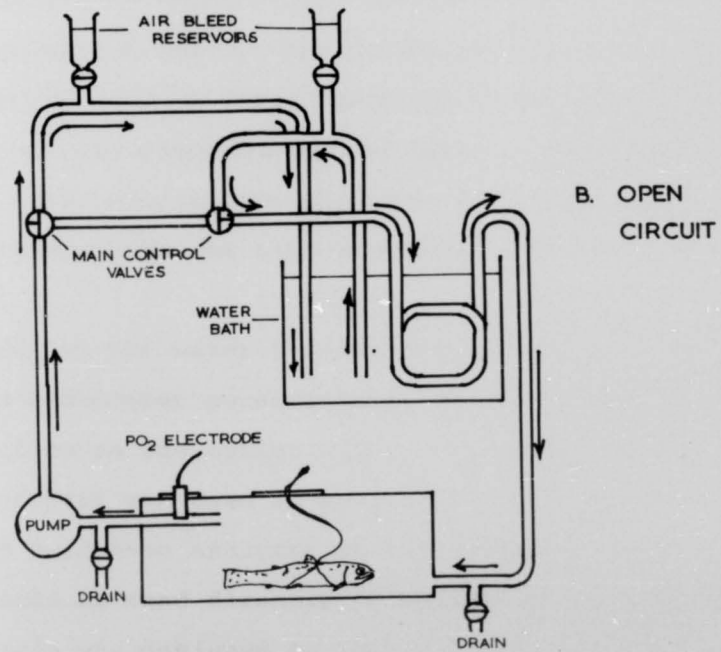
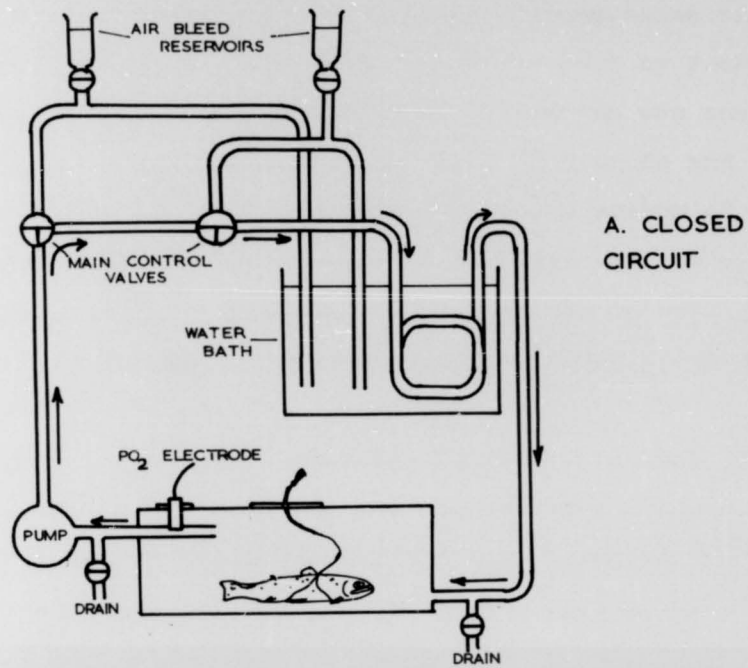

perspex box of internal dimensions corresponding closely to the dimensions of flume fish chamber; 56cm by 23cm by 21cm (Fig 10). An access hatch in the top was sealed by a foam neoprene gasket and was held by 4 studs and wing nuts. 3 brass studs passed through the centre of the hatch to which ECG electrode wires to the fish were soldered. The electrode arrangement on the fish was exactly as used in the flume experiments and care was taken to ensure proper contact of the earthed screening with the water in the chamber. The actual electrode cables were insulated from the water by using an aerosol lacquer spray on the soldered terminals. A small centrifugal pump (Charles Austen Pumps Ltd. model Cl6 300) drew water from an outlet at the top of one end of the box and circulated it through a coil immersed in a constant temperature water bath and back to the box via an inlet at the bottom of the other end (fig. 11). By a system of valves this closed circuit could be opened so that fresh aerated water was drawn from the constant temperature bath into the respirometer and back into the water bath (fig. 11b). For convenience the flume was used as the constant temperature bath for this experiment and as a store of aerated water.

$PO_2$  of the water leaving the respirometer was monitored with a Radiometer polarographic electrode inserted into the water flow in the outlet tube. A Radiometer  $PO_2$  electrode (type E5046) was used in conjunction with a Radiometer type PHM71B Acid-base Analyser on the galvanometer scale of which  $PO_2$  could be read directly in mm Hg. The insertion of the electrode was designed so that the body of the electrode was immersed in and kept at the temperature of the respirometer

water. The volume of the respirometer box and the closed circuit plumbing was 24,620 l. and the flow through the pump was 1.75 l/min. or one respirometer volume in 14 minutes. This together with the mixing effect of the flow ensured adequate sampling of the water  $PO_2$ .

#### EXPERIMENTAL PROCEDURE.

All experiments were carried out at  $15^{\circ}C \pm 0.5^{\circ}C$  on rainbow trout acclimated to that temperature.

The fish was anaesthetised and the ECG electrodes were implanted as described before. It was then transferred into the respirometer to recover from anaesthesia. The access hatch was screwed down firmly ensuring that the chamber was free from air bubbles. The main control valves were then set to the open circuit position and the fish was allowed to recover from anaesthesia with the respirometer being perfused with aerated water.

The oxygen electrode was calibrated in air saturated water and in zero  $PO_2$  solution (barium thiosulphate) prior to experiments with each new fish. The 100% saturation value calibration was frequently rechecked but the zero  $PO_2$  reading was very stable (being independent of membrane properties which are liable to variations) and was checked less frequently. The reading to which the 100% saturation calibration was set was calculated from the barometer pressure:-

$$(P - SVP) \times \frac{21}{100} = PO_2 \text{ mm Hg at 100\% saturation}$$

P = Atmospheric pressure mm Hg

SVP = Saturated vapour pressure of water mm Hg

$\frac{21}{100}$  = approximate fraction of oxygen in dry air.

Once the fish had recovered from anaesthesia the  $PO_2$  electrode was inserted into the respirometer and the first "respiration run" was commenced with the  $PO_2$  in the respirometer close to the saturation value.

Prior to the respirometer run the main control valves were turned to the closed circuit position and the electrocardiograph was set to start recording at an appropriate speed. After about 3 minutes the actual start of the run was marked on the ECG and the first  $PO_2$  reading was taken.  $PO_2$  readings were taken at 5 minute intervals for 45 minutes while the ECG was being recorded (i.e. 10  $PO_2$  readings per run). At the end of the run the control valves were turned to open circuit to allow replenishment of oxygen in the respirometer. If the oxygen consumption rate was low two runs were often made consecutively without replenishment of water but the  $PO_2$  in the chamber was never allowed to fall as low as 70% saturation when the effects of hypoxia could be expected to become manifest (Randall & Smith 1967).

The number of heart beats in alternate minutes on the ECG were counted and their mean was calculated to give the mean heart rate during the particular run. The  $PO_2$  readings were plotted graphically against time and a straight line was fitted to them by eye. Maximum deviations from the line never exceeded 2mm Hg so no difficulty was encountered in obtaining an accurate fit. The nominal starting and finishing  $PO_2$  were then read off the line for calculation of the rate of oxygen

consumption as follows:-

$$\frac{PO_2 \text{ start}}{PO_2 \text{ sat}} \times 100 = \%C_{\text{start}}$$

$$\frac{PO_2 \text{ end}}{PO_2 \text{ sat}} \times 100 = \%C_{\text{end}}$$

$PO_2 \text{ start}$  = partial pressure  $O_2$  mm Hg at start of run (nominal)

$PO_2 \text{ end}$  = partial pressure  $O_2$  mm Hg at end of run (nominal)

$\%C_{\text{start}}$  = per cent saturation at start of run.

$\%C_{\text{end}}$  = per cent saturation at end of run.

The per cent saturation figures ( $\%C$ ) were then converted to mg/litre (C) using the nomogram of Hart (1967). Then the oxygen consumption in mg per kilogram of fish per hour was:-

$$\frac{(C_{\text{start}} - C_{\text{end}}) 24.62 \times 1.333}{W 1000} = O_2 \text{ consumption mg/kg/hr}$$

24.62 = respirometer volume litres.

1.333 = corrects reading to 1 hour.

W = weight of fish in grams.

Runs were repeated on each fish for up to 6 days. Apart from avoiding the obvious effects of anaesthesia no effort was made to select times for runs when the fish was not excited or disturbed. The aim of this work was to investigate as fully as possible the bounds of variation in the relationship between heart rate and oxygen consumption. Often during a run the fish was quite active.

The Fish Bending Machine & Experiments on Dorsal aorta  
function

THE FISH BENDING MACHINE

As a basis for studying the influence of fish body movements on blood circulation a number of experiments on trout cadavers and artificial models were carried out on a fish bending machine which could simulate fish swimming movements.

One of the anticipated advantages of simulating fish swimming movements was the possibility of carrying out work at high "swimming speeds" which could not be sustained for more than a few seconds by an actual living fish. It was thus regarded as very important to be able to reproduce high swimming speeds which could not be investigated in any other way. Thus at the outset the specifications of the machine were laid down:-

1. A 30cm fish should be used; this is large enough to allow sufficiently precise dissection and cannulation of the blood vessels.
2. The maximum tail beat frequency attainable should be at least 12 hz.
3. The speed should be continuously variable over wide range of speeds.

The actual swimming wave to be used was derived from the literature and is discussed in this thesis in the analysis of dorsal aorta function (fig 38).

The design initially suggested was for a set of transverse slides to which the fish could be attached. These could be moved to and fro by a system of cranks or cams. The high

Figure 12. The fish bending machine used for simulation of fish swimming movements. A, electric motor. B, variable speed drive pulleys. C, speed control lever. D, crankshaft. E, slide bed. The fish is placed between the upright pins on the slides.

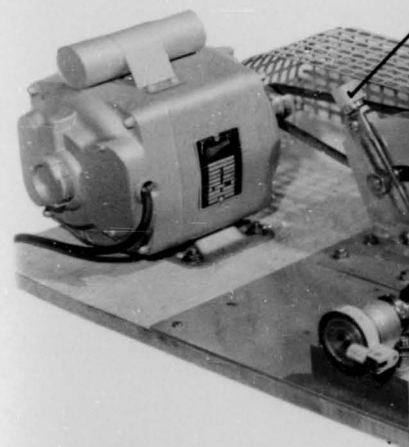
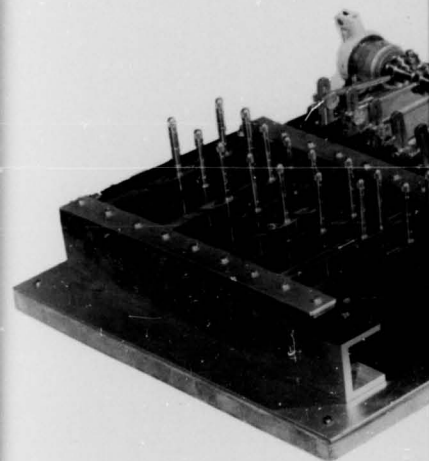



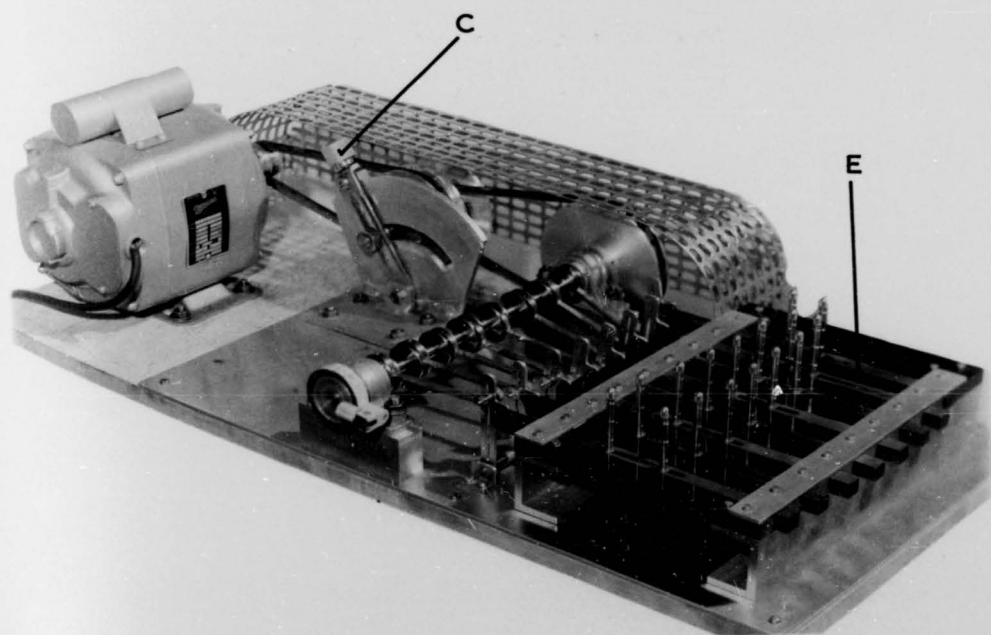
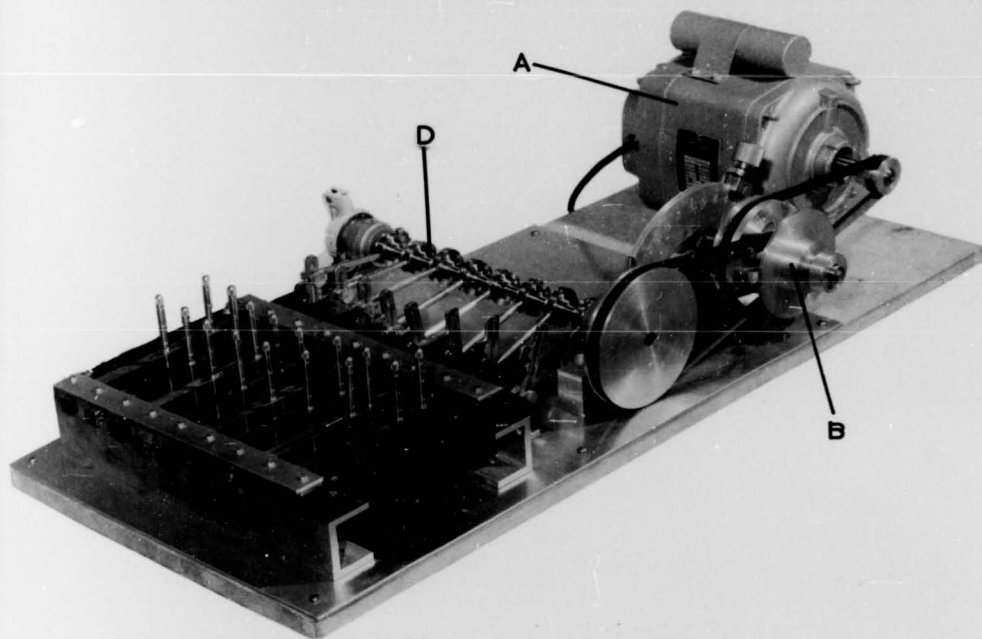

d for  
movements.  
ble speed  
rol lever.  
The fish  
t pins on

S/T

Figure 13. Fish bending machine; Plan and transverse section of the slide bed. Only one connecting rod and crank assembly is shown in the plan attached to the anterior slide. All the linkages and cranks for the slides are identical, the amplitude being adjusted by moving the gudgeon pin up or down the vertical lever as shown.

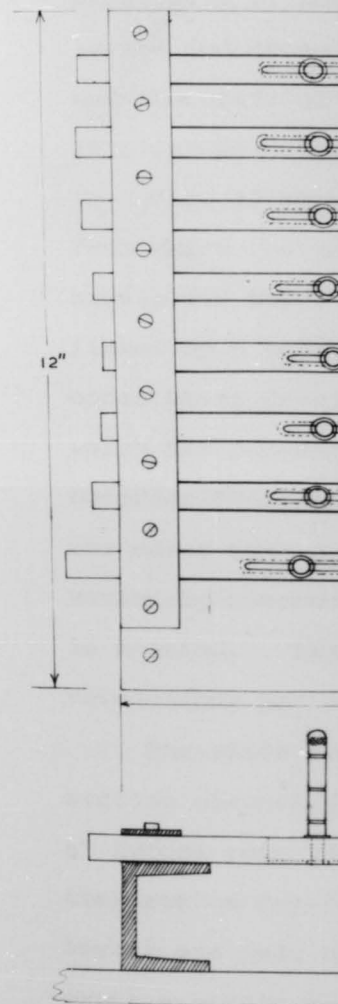

transverse  
one  
y  
the  
es and  
cal, the  
ng the  
cal

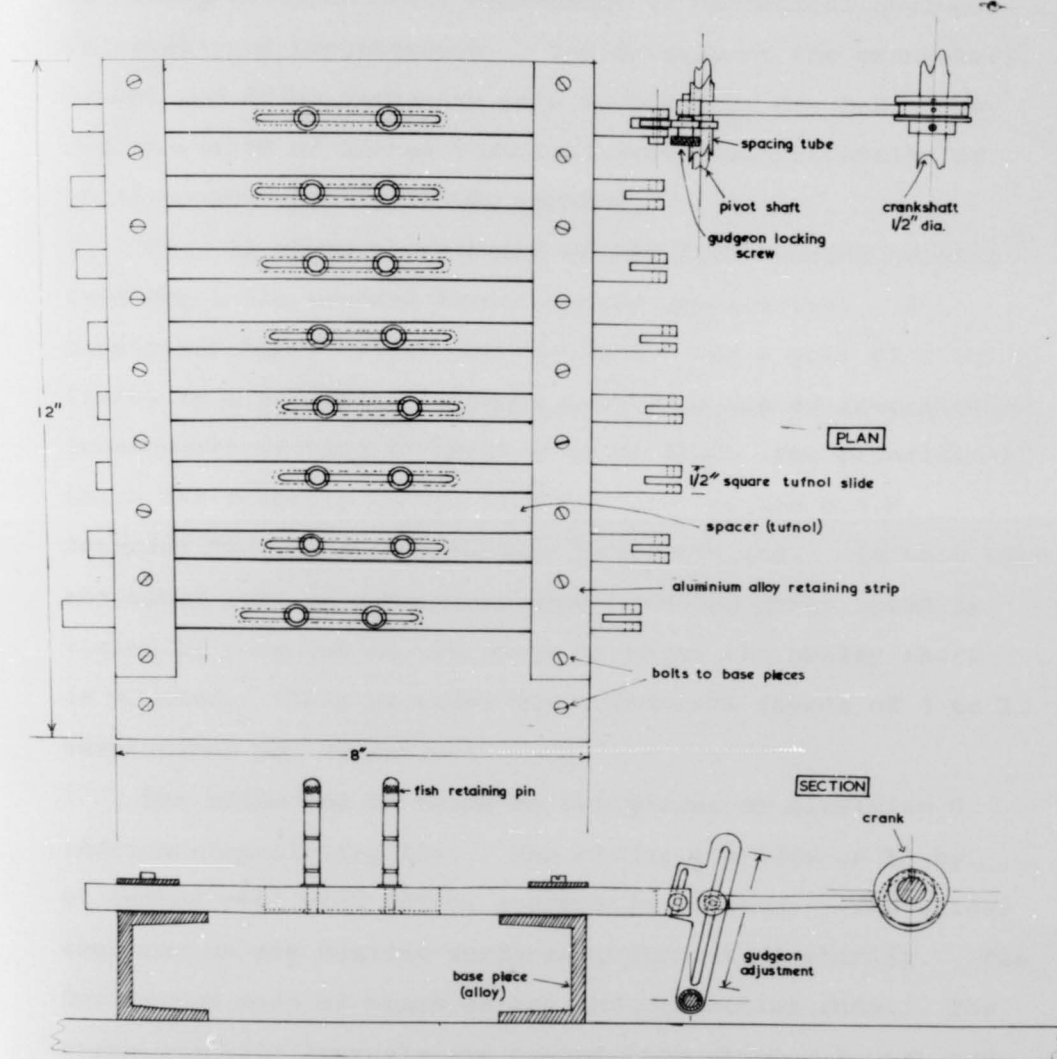

PL.

S/T

speeds required appeared to be major difficulty. The final design of the main bed of the machine and transverse slides was suggested by Mr. R. Vitols of the Textile Machinery Research Unit, Department of Mechanical Engineering, University of Loughborough. The details of the crankshaft, levers and drive mechanism were designed by Mr. B.E. Povey and the staff of Shared Technical Services, University of Stirling who also built the machine.

Fig. 12 shows photographs of the fish bending machine from which the general layout can be appreciated. A  $\frac{3}{4}$  horsepower motor drives the crankshaft via a pair of V belts linked by a pulley arrangement made of a set of interlocking cones which provide a variable speed drive (the principle of which has recently become most familiar in the D.A.F. motorcar "variomatic" automatic transmission). In this case the motor runs at a constant speed and the drive speed is varied by movement on the lever on which the pulley shaft is mounted. This provides for crankshaft speeds of 3 to 13 revolutions per second.

The slide bed is based on two pieces of aluminium U section channel (fig 13). The slides are made of  $\frac{1}{2}$ " by  $\frac{1}{4}$ " tufnol rods with tufnol spacers in between. The slides thus run on dry bearing surfaces quite satisfactorily. The levers are made of brass as are the connecting rods. The crank eccentric journals are turned from phosphor bronze and the crank big end bushes are steel. The phase angle of the eccentrics relative to the shaft is readily adjustable with set screws which lock the eccentric onto the shaft. The

amplitude of the slide movement is adjustable by altering the position of the connecting rod pivot on the lever. The position of the fish retaining pins on the slides can also be adjusted in order to centre the fish on the slide bed.

The machine is capable of reproducing a wide variety of transverse oscillatory movements (approximately sinusoid) in anything attached to the slides at frequencies of 3 to 13hz.

Two main series of experiments were carried out on the machine:-

1. Test on a cannulated dorsal aorta preparation in a dead fish.
2. Tests on an artificial model of the dorsal aorta.

Both sets of experiments were performed with the machine set up to reproduce the idealised swimming waveform of a 30 cm fish.

#### EXPERIMENTS ON TROUT DORSAL AORTA PREPARATIONS.

Fish of 30 cm  $\pm$  1cm were used in these experiments. A dissection was carried out from the ventral aspect to expose the dorsal aorta in the body cavity region and up to the confluence of the first two branchial arteries. The viscera and the ventral cranial region including the lower jaw were removed for this purpose. The fish was then attached ventral side uppermost to the slides on the bending machine by tying it with wires to the retaining pins. Care was taken to ensure correct alignment of the vertebral column in both horizontal and vertical planes. The third and fourth branchials, subclavian and anterior mesenteric arteries were

then ligatured. A 1.3mm O.D. flexible cannula was then inserted into the anterior part of the dorsal aorta where the first two branchial arteries join; the position used by Smith & Bell (1964) for dorsal aorta cannulation. This cannula was ligatured into place and at a distance of 5cm was connected to a 5mm bore tubing which supplied saline from a constant head device.

The caudal artery was exposed and cannulated using a 1mm diameter flexible cannula which was connected to a pressure transducer. This cannula fitted tightly in the caudal artery and its end could be pushed forward to measure pressures in the aorta in the trunk region. Occasionally a cannula was also inserted into the anterior mesenteric artery in order to monitor pressures at the anterior end of the aorta.

The aorta was thus perfused with saline with a head corresponding to the pressures measured by Stevens & Randall (1967a) and the output pressures could be measured during body movements reproduced by the machine.

Several technical problems emerged during this work:

If the inlet tubing from the reservoir was of a small diameter as soon as flow began a large head loss was noticed and the pressure actually applied to the aorta was considerably smaller than the static head apparently applied. This is to be expected from Bernoulli's theorem and in experiments with cannula tubing when flow rates are measured in terms of drop counts head losses in excess of 50% were noted. This may be the cause of unexpectedly low flow rates observed in in vitro gill perfusion experiments (Rankin 1970). This effect was

minimised in these experiments using a wide bore feed tube and keeping the small bore section as short as possible. Also the height of the constant head reservoir was raised to a level which produced the appropriate pressure in the dorsal aorta during flow.

The pressure transducer and attached cannula were chosen to have a high enough frequency response to allow measurement of the anticipated pressure pulses. However cannula movement during working of the machine very readily produced pressure pulses independent of any pumping activity in the dorsal aorta. Careful damping of the cannulae could minimise this effect but artefacts could never be satisfactorily distinguished from real pumping pulses of the aorta. As it proved impossible to reliably determine pulse pressures, the experiments turned to the determination of mean pressure changes, either using the pressure transducer or simply measuring the height of the saline column in the caudal cannula which was held vertically against a scale.

#### EXPERIMENTS ON DORSAL AORTA MODELS.

A 5mm i.d. transparent flexible plastic tube was used in this work to represent a fish dorsal aorta. In some preliminary experiments it was simply laid along the bed of the fish bender in a groove in a block of flexible rubber foam. The "anterior" end was put into a beaker of water and the "posterior" end was put into a measuring cylinder. It was ensured that the tube was filled with water and any pressure rise due to pumping activity when the bender was set into motion was noted as a rise in the water level in the measuring cylinder.

- Figure 14. A. The dorsal aorta model used in basic studies on the Burne pump mechanism. The elastic band inside the tube is anchored by sutures across the lumen of the tube near each end.
- B. The arrangement used for measurement of maximum output head from the dorsal aorta model.
- C. The arrangement used for measurement of flow from the dorsal aorta model at different pressure heads. The outflow volume from the displacement vessel was measured over a set time period in order to determine flow rates.

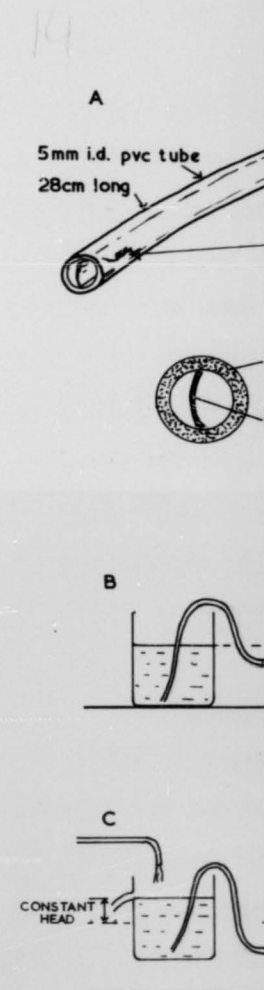



in basic  
mechanism.  
tube is  
the lumen

asurement  
the dorsal

asurement

ta model

. The

placement

set time

e flow rates.

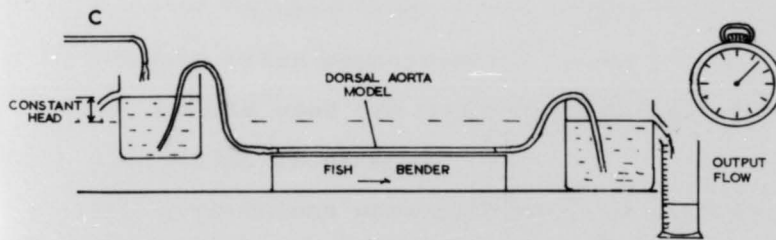
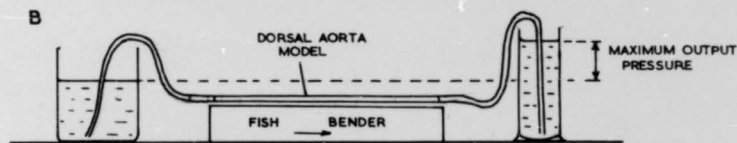
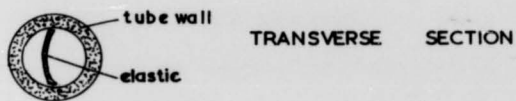
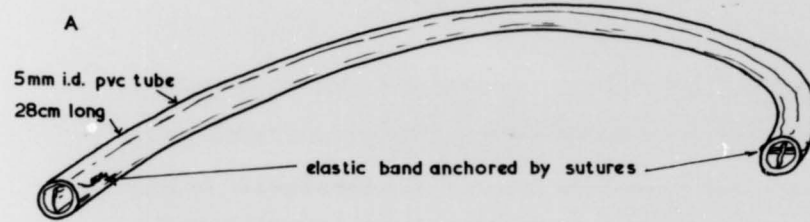

The basic work was carried out on a model consisting of the above tube with a flat rubber elastic band stretched along its bore dividing the lumen into two halves longitudinally (fig. 14). The maximum pressure difference this was capable of producing was determined in the measuring cylinder as above.

In normal function of the dorsal aorta a pressure difference is set up across it by the heart. This was simulated by setting up a constant head between the two ends of the tube. An Archimedian displacement vessel replaced the measuring cylinder at the "posterior" end and the overflow from this was measured during a timed period. The flow through the model was thus measured at zero, 20 mmH<sub>2</sub>O and 40 mm H<sub>2</sub>O pressure drop across its length at a wide range of oscillation frequencies. The "tail beat" frequency was monitored on the oscillograph using the tip of a water filled cannula from the pressure transducer attached to one of the slides.

#### Anatomical and Histological Techniques

The anatomy of the circulatory system and associated structures of rainbow trout were investigated using a variety of techniques often complementary to each other. Some of the main methods used are described below.

##### BASIC ANATOMICAL TECHNIQUES

Many dissections were carried out on whole fish or parts of fish in order to elucidate particular points. Conventional techniques were used with the aid of a binocular-zoom stereomicroscope. Preparations were often fixed and preserved in dilute formalin solution or in alcohol which was particularly

useful for clearing in the case of nerve dissection. Staining with osmium tetroxide was used in dissection of the nervous system.

#### INJECTION AND CASTING TECHNIQUES.

To facilitate dissection of the vascular system the blood vessels were often injected with "Silescol" silicone rubber moulding paste.

The heavily anaesthetised fish was injected intravascularly with Heparin usually by inserting a hypodermic needle into the ventricle. The structures to be studied were then partially exposed by dissection. The silicone rubber paste was then mixed with the catalyst and drawn into a 1ml disposable syringe. The part of the vascular system being investigated was injected using a 19 gauge needle. For the heart and afferent branchial arteries the ventricle was a convenient injection site. The efferent branchial arteries and dorsal aorta etc. could be injected by a needle inserted directly into the dorsal aorta. The major veins were injected via the posterior cardinal vein in the trunk region of the kidney. No ligatures were used but the needle was left in situ blocking the injection hole until the rubber began to harden. About one hour was allowed for the rubber to set and then dissection could proceed.

Casts of particular items of interest such as the heart and dorsal aorta were often removed for more detailed study and measurement. In this case the tissues were cleared from the cast with concentrated hydrochloric acid the residue being washed away with fine jets of water from a syringe needle.

Prolonged immersion of the rubber in acid tended to render it transparent so that it was found best to alternate short periods of immersion in acid with washing and dissection with fine instruments.

Colouring agents could also be added to the rubber. Eosin was quite successful but tends to diffuse out into surrounding tissues if the cast is left in situ; in this case pigments would be more appropriate than stains or dyes.

#### OSTEOLOGY

In investigating certain aspects of the caudal lymph heart anatomy and interpreting sections of the trunk region an understanding of the skeletal system was important. The skeleton was extracted by immersing the dead fish for about 15 minutes in boiling water after which it was relatively easy to dissect away the surrounding soft tissues. Immersion in alcohol was useful in removing fatty deposits around some structures.

#### THICK SECTIONS.

It was found that some fish about 25cm long which had been left in slightly acid formalin solution for more than 9 months had become entirely decalcified. Using a razor or sharp scalpel transverse sections about 2 to 3mm thick were cut. A series of these slices through an entire fish was particularly useful in the study of the lymph system which is difficult to see in ordinary dissection.

## HISTOLOGY.

All the basic histological techniques were carried out as described in Mahoney (1969).

Structures such as the dorsal aorta and the caudal lymph heart are in very close proximity to bone so the material had to be decalcified before sections could be cut. The tissue was immersed in Gooding and Stewart's fluid for 7 to 10 days and tested for decalcification as described by Mahoney.

In some cases sections were required of the heart ventricle or bulbus in the expanded state. For this, the chamber was excised and a blunted syringe needle was inserted through one opening and a ligature was placed round the needle. Another ligature closed off the other opening. Warm agar solution or "Vaseline" was then injected from a syringe in order to expand the chamber. The needle was withdrawn and its ligature was drawn tight. The heart chamber was then fixed and sectioned in the inflated state as for any other tissue.

All tissues in this work were fixed in formol-saline, imbedded in paraffin wax and sectioned according to standard procedures. Three staining techniques were used:-

Erlich's Haematoxylin and Eosin as general stain.

Van Gieson's stain which selectively stains collagen.

Orcein Elastica a specific stain for elastic tissue.

Procedures were as described by Mahoney (1969) except that Van Geison's stain was often couterstained with Erlich's haematoxylin.

Figure 15. The apparatus used for investigation of the bulbus arteriosus pressure-volume relationship.

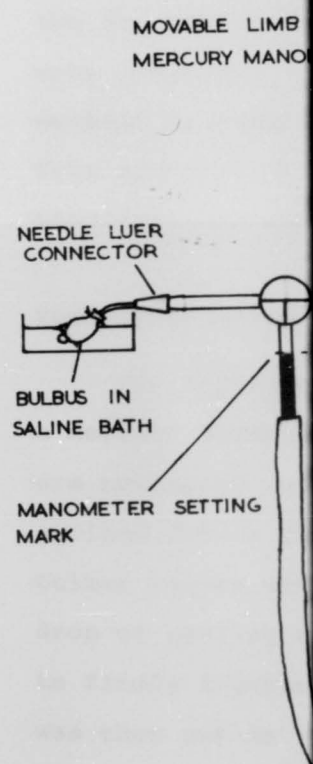

stigation  
essure-

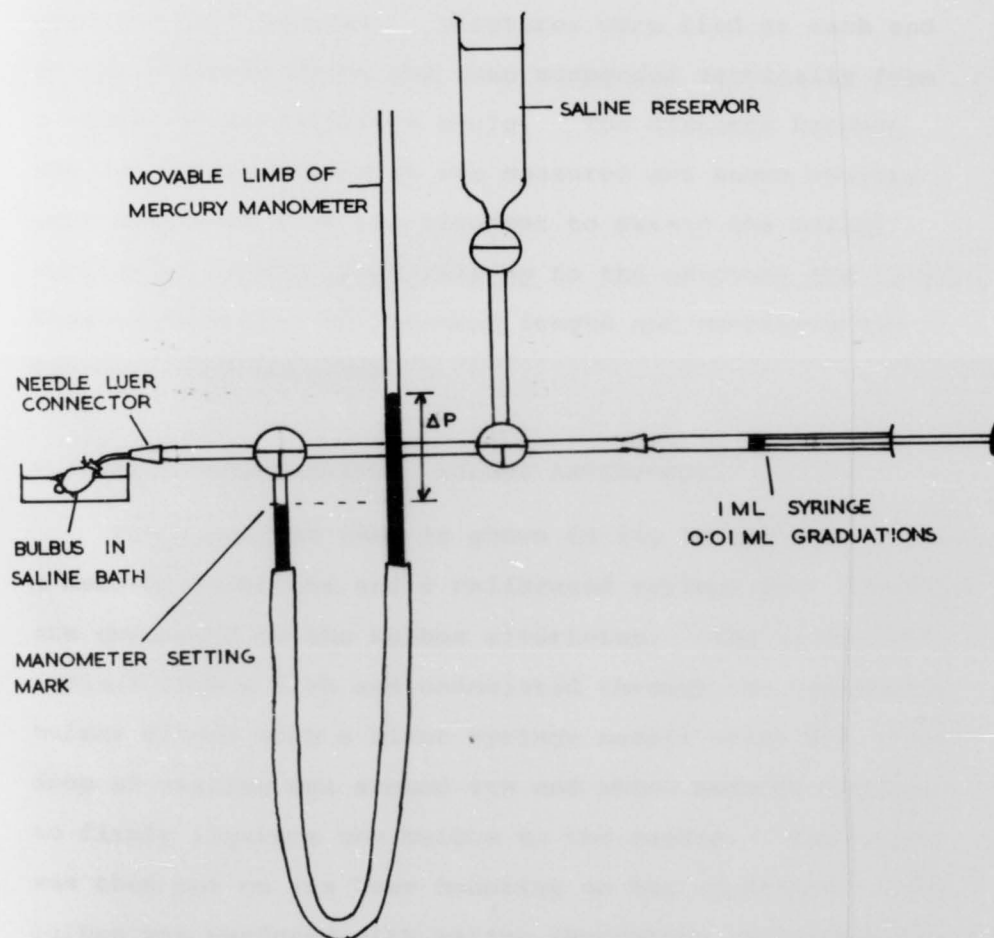

PL.

S  
T

## ELASTICITY MEASUREMENT - DORSAL AORTA LIGAMENT.

A fish was dissected to expose the dorsal aorta ligament. Two ligatures were tied around the ligament 5cm apart in the trunk region; these acted as markers. Then the section of ligament between the cranium and the first hypural arch was removed taking care to keep it moist with saline. Burnstock's (1967) trout saline was used for this purpose. Ligatures were tied at each end of the ligament which was then suspended vertically from a retort stand against a scale. The distance between the two marker ligatures was measured and known weights were suspended from the ligament to extend the marked section by regular intervals up to the original 5cm length. Thus measurements of ligament length and corresponding tensions were obtained.

## ELASTICITY MEASUREMENT - BULBUS ARTERIOSUS.

The apparatus used is shown in fig 15 and consists of a mercury manometer and a calibrated syringe both of which are connected to the bulbus arteriosus. The bulbus was excised from a fish and cannulated through the ventriculo-bulbar valves with a blunt syringe needle which had a small drop of sealing wax around its end which made it possible to firmly ligature the bulbus to the needle. The needle was then put on its Luer mounting on the apparatus. The bulbus was perfused with saline (Burnstock 1967) from the reservoir and it was ensured that the apparatus was free



from air bubbles. The ventral aorta end of the bulbus was then ligatured off, the manometer was set to zero pressure and the valve to the reservoir was closed off.

The experiment began with the bulbus quite flaccid. The piston of the syringe was advanced by 0.01ml and the free end of the manometer was moved to return the lower end of mercury to the zero reference mark and the height of mercury in the movable manometer limb was noted. This procedure was repeated for increasing volume increments up to 120mm Hg pressure. Then some measurements were taken with decreasing volumes down to the original volume. The cycle of expansion and contraction taking volume and pressure readings took 10 to 15 minutes.

#### Intact fish

Four intact rainbow trout were tested at 5.5°C. When the fish at rest the heart rate stabilized at 25 to 35 beats/min. (Table 1). Fig. 1a shows a typical ECG at rest and it can be seen that the heart to heart interval varies considerably. During periods of excitement or if the stomach was full, the resting heart rate was elevated for long periods up to a maximum rate of 45 beats/min. Bursts of spontaneous activity gave rise to maximum heart rates of about 60 beats/min. for periods of not more than one or two minutes. During a typical burst of this kind lasting about 15 seconds, the heart

## RESULTS, OBSERVATIONS &amp; ANALYSIS

Swimming tests and Heart rate Measurements.

In order to facilitate comparison of swimming performances all speeds are expressed in terms of specific swimming speed or body lengths per second (Bainbridge, 1958).

$$\text{specific speed (V/L)} = \frac{\text{velocity (cm/sec)}}{\text{body length (cm)}}$$

The analysis may be obscured if the heart rate is different in fish of different sizes but no such effect was observed in the narrow size range used. The results of Nomura et al (1972) for much larger rainbow trout confirm that any size effect is probably small. The results of individual speed trials in each experimental fish are given in Appendix I. The final statistically condensed data in the form of mean heart rates and regression equations is given in table I.

## THE RELATIONSHIP BETWEEN SWIMMING SPEED AND HEART RATE AT 6.5°C.

Intact fish

Four intact rainbow trout were tested at 6.5°C. With the fish at rest the heart rate stabilised at 25 to 35 beats/min. (Table 1). Fig. 16a shows a typical ECG at rest and it can be seen that the beat to beat interval varies considerably. During periods of excitement or if the stomach was full, the resting heart rate was elevated for long periods up to a maximum rate of 45 beats/min. Bursts of spontaneous activity gave rise to maximum heart rates of about 60 beats/min. for periods of not more than one or two minutes. During a typical burst of this kind lasting about 10 seconds, the heart

TABLE I. Comparison of heart rates in intact and vagotomised fish at 6.5°C and 15°C.

Condition of fish	Basal heart rate Beats/min.		Maximum heart rate Beats/min.		Regression line for intermediate heart rates.		
	Mean	S.D.	Mean	S.D.	Equation	Correlation coefficient	P
Intact 6.5°C	32.54	3.81	55.61	0.74	Log.H.R.= 1.3342 + 0.3038(V/L)	0.8965	<.001
Unilateral vagotomy 6.5°C	34.56	1.82	56.81	0.85	Log.H.R.= 1.3821 + 0.2658(V/L)	0.8669	<.1
Bilateral vagotomy 6.5°C	48.25	4.27	52.49*	3.70*	Log.H.R.= 1.6846 + 0.0363(V/L)*	0.3726*	<.1*
Intact 15 C	45.52	6.18	93.76	3.78	Log.H.R.= 1.5639 + 0.1937(V/L)	0.8290	<.001
Unilateral vagotomy 15 C	37.26	3.38	96.20	2.81	Log.H.R.= 1.4894 + 0.2505(V/L)	0.9617	<.001
Bilateral vagotomy 15 C	45.13	9.46	82.67	2.28	Log.H.R.= 1.5927 + 0.1826(V/L)	0.8292	<.001

H.R. = Heart rate. P = Level of significance of regression correlation.

\* These values were calculated by incorporating all the heart rate figures above 0.2(V/L).

Figure 16. ECGs of intact and bivagotomised rainbow trout at 6.5°C. The intact fish shows irregularity in the beat to beat interval whereas the bilaterally vagotomised fish has a regular cardiac rhythm.

INTACT



BIVAGOTOMISED



nised rainbow  
e fish shows  
beat  
rally  
lar cardiac

INTACT



BVAGOTOMISED



1 MIN

PL.

S/T

Fig. 17. Intact fish at 6.5°C. Heart rates during the course of three speed trials. Circles - 1.07(V/L). Triangles - 1.38(V/L). Squares - 1.66(V/L).

BEATS/MIN

70

t rates during  
rials. Circles -  
B(V/L). Squares -

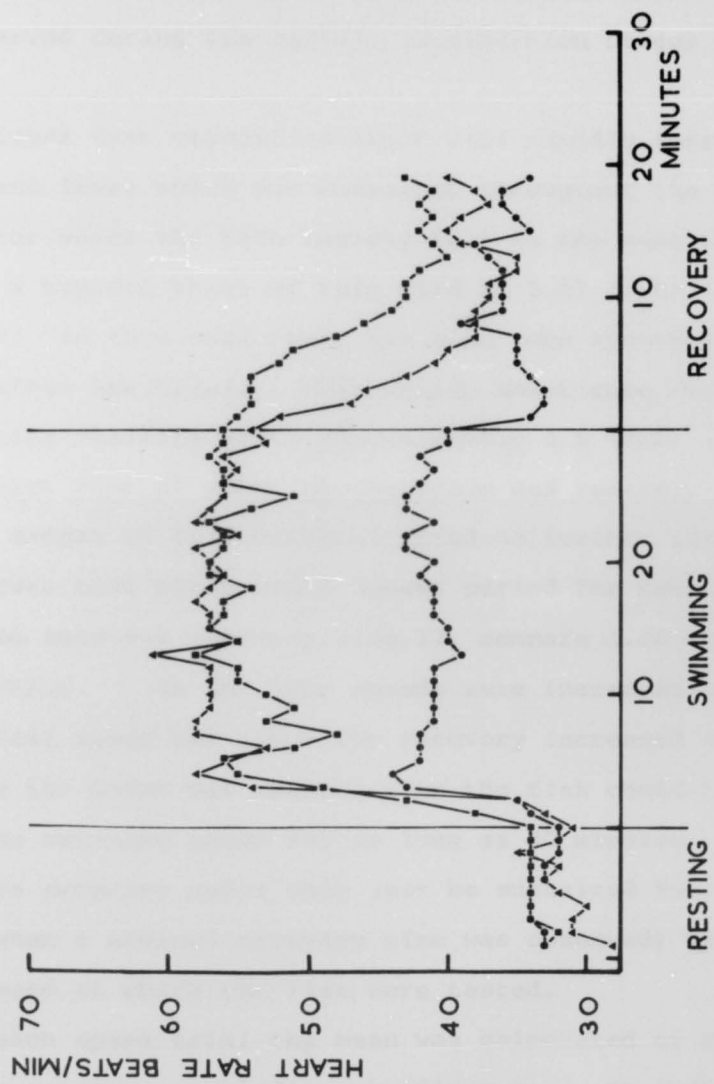

PL.

S/T

often slowed or stopped and the peak heart rate was reached approximately 30 seconds after the peak of activity.

Speed trials at below 0.6 (V/L) had no significant effect on the heart rate apart from the cardiac inhibition often observed during the initial acceleration stages of a test.

At higher test velocities heart rate rapidly increased to a uniform level which was sustained throughout the test period after which the rate rapidly fell to the resting levels. A typical trial of this kind at 1.07 (V/L) is shown in fig. 17; in this case there was also some spontaneous activity after the trial. This active heart rate increased with swimming velocity up to approximately 1.5 (V/L) when the maximum heart rate of about 56 beats/min was reached. In trials in excess of this critical speed no further increase in heart rate took place and a longer period for return to the resting rate was observed (fig 17, compare 1.38 (V/L) and 1.66 (V/L). As the test speeds were increased above this critical speed the times for recovery increased and eventually the point was reached when the fish could not sustain the swimming speed for as long as 30 minutes. This point where swimming could only just be sustained for 30 minutes (when a maximal recovery time was observed) was the maximum speed at which the fish were tested.

For each speed trial the mean was calculated of all the heart rate readings, excluding the first five, in order to discount the disturbances associated with the initial acceleration.



Fig. 18. 6.5°C. The relationships between heart rate and swimming speed.

A. Intact fish. Open circles are data from unilaterally vagotomised fish inserted for comparison but not used in the calculation of the lines shown.

B. Bilaterally vagotomised fish. The line shown is the mean basal heart rate; no significant relationship could be derived for the heart rates during swimming.

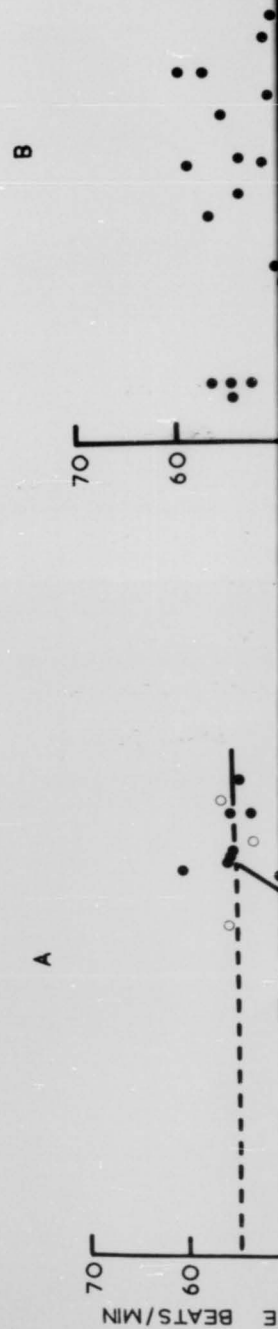

between heart

es are data

ed fish

not used in

s shown.

fish. The

l heart rate;

could be

during

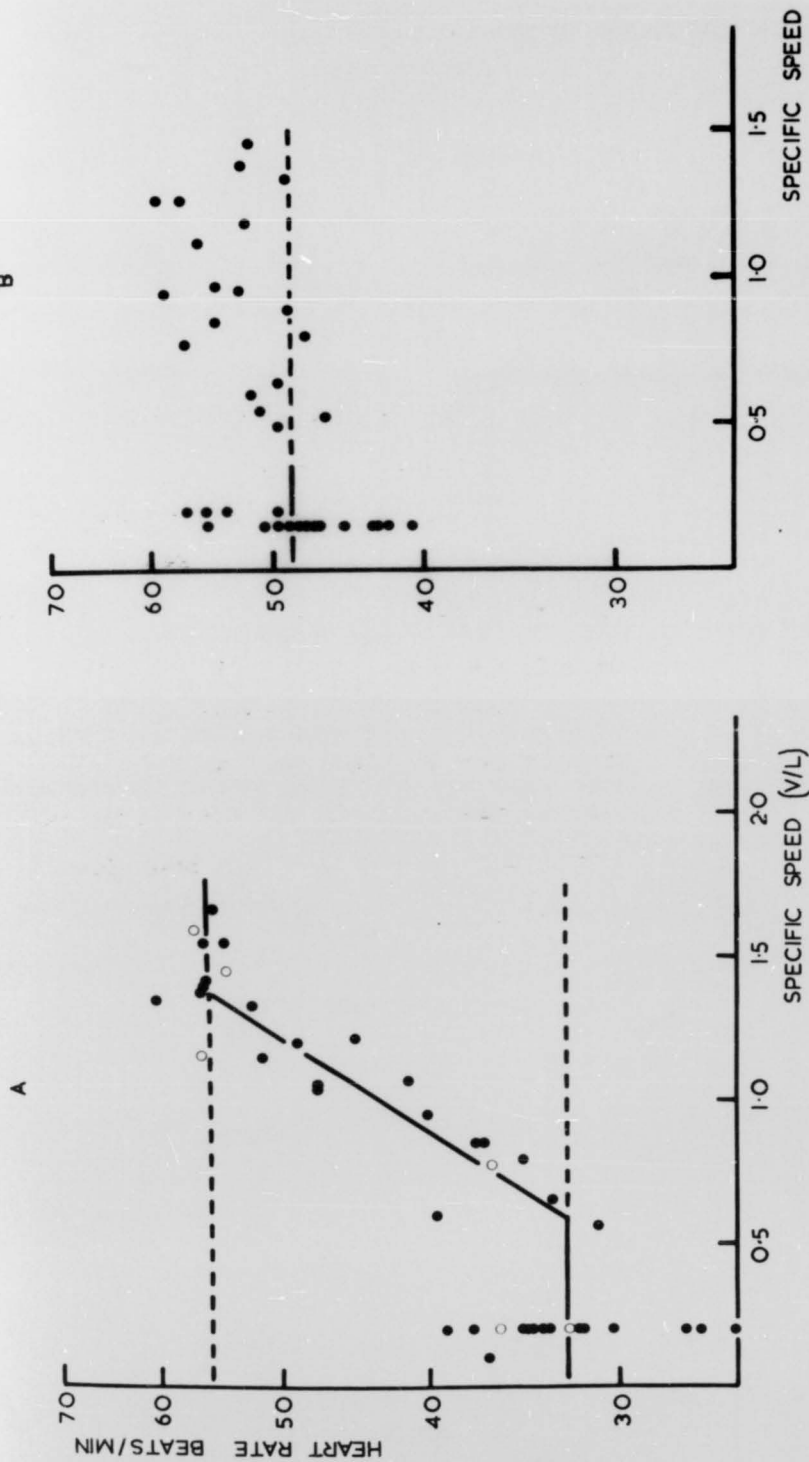

PL.

5/1

Figure 19. The relationships between swimming speed during a trial and the time taken during recovery for the heart rate to fall half way back to the level prior to exercise (50% recovery time).

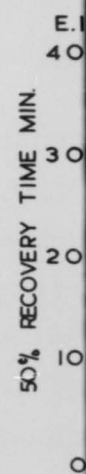
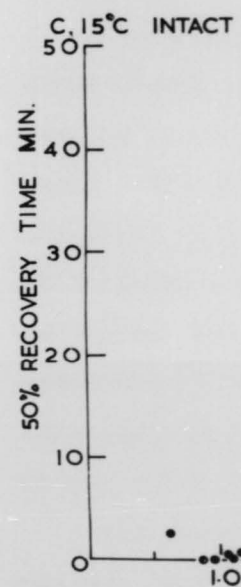
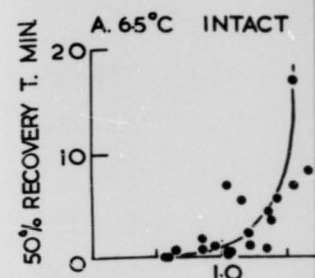

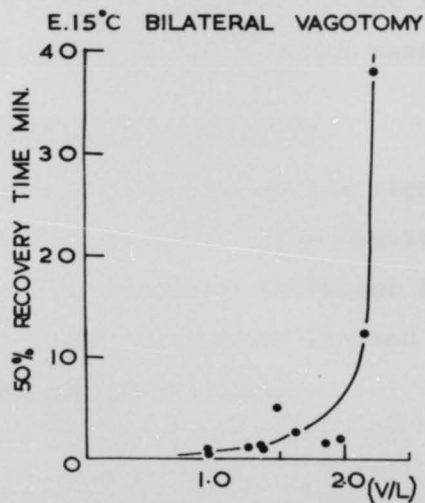
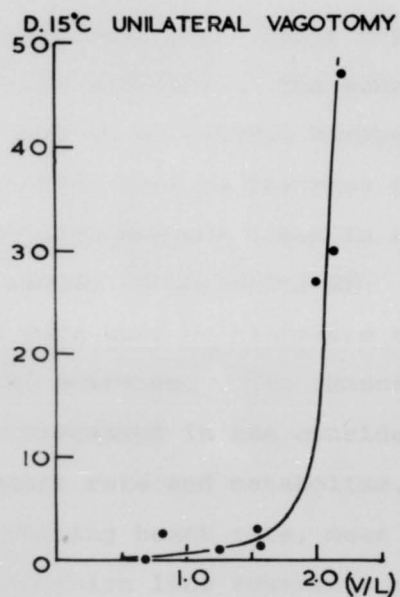
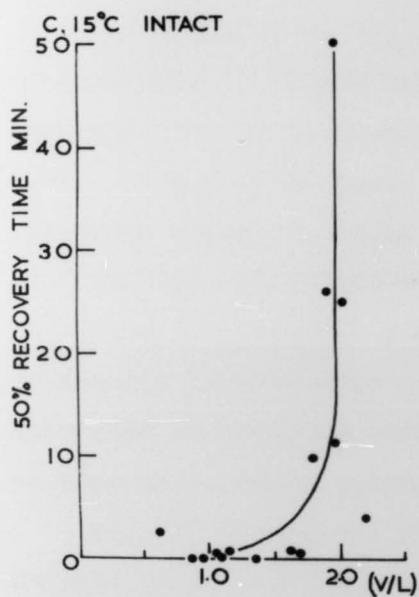
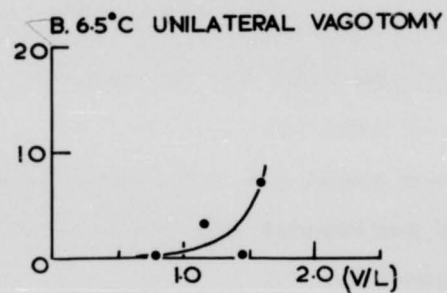
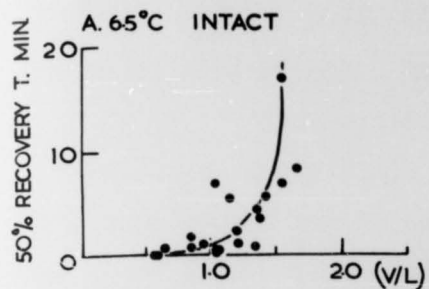

swimming speed  
 e taken during  
 e to fall half  
 t to exercise

The logarithms of these mean values are plotted against swimming speed in fig. 18a. The mean of the readings at rest for 20 to 30 minutes prior to each test are also plotted

The time taken after a speed trial for the heart rate to fall half way to the prior resting level was determined and the inter-relationship between this time for 50% recovery and trial speed is shown in fig. 19a.

For analysis in fig. 18a the velocity - heart rate relationship is broken into three segments. The mean resting level (0.2 (V/L)) is shown as an initial horizontal line. The maximum heart rate was taken as the mean of all the heart rates of trials with 50% recovery times in excess of 5 minutes (i.e. speeds in excess of the critical). The remaining intermediate points were used to calculate the regression line between the two extremes. The reasons for this kind of analysis will be discussed in the consideration of the relationship between heart rate and metabolism.

All the values for mean resting heart rate, mean maximum heart rate and the regression line equations are given in table 1. In contrast to the resting levels there was little variation in the maximum heart rate.

#### The effect of unilateral vagotomy

One fish was vagotomised on the right side only with a sham operation on the left. The results of swimming tests were in no way significantly different from those in the intact fish as shown in figures 18a and 19b and all the features of the ECG were normal.

Figure 20. Bilaterally vagotomised fish at 6.5°C.  
Heart rates during the course of three  
speed trials. Circles - 0.97 (V/L).  
Triangles - 1.12 (V/L). Squares -  
1.97 (V/L).

70  
60  
MIN

sh at 6.5°C.  
rse of three  
.97 (V/L).  
uares -

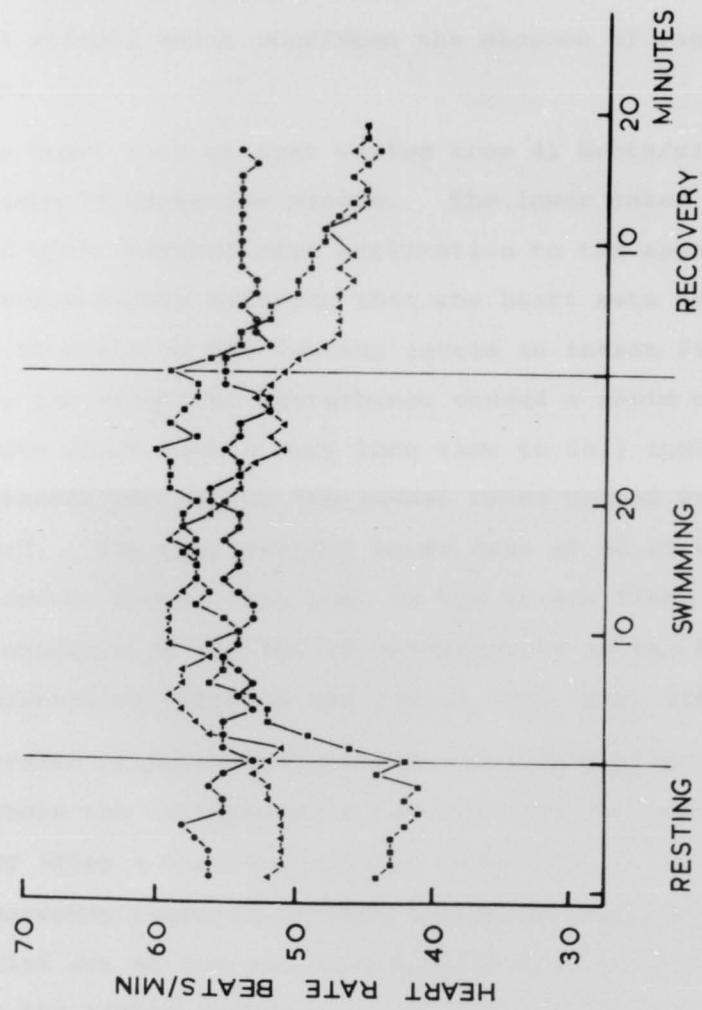

PL.

S/T

The effect of bilateral vagotomy

Bilateral vagotomies and swimming tests were carried out on two rainbow trout at 6.5°C. No cardiac inhibitory reflexes were observed in response to visual or other external stimuli which confirmed the absence of vagal function.

The heart rate at rest varied from 41 beats/minute to the maximum 56 beats per minute. The lower rates were only recorded after several days acclimation to the apparatus and then there was some evidence that the heart rate tended to decline to close to the resting levels in intact fish. However, the slightest disturbance caused a rapid rise in heart rate which took a very long time to fall again so that extended periods at the lowest rates proved impossible to record. The mean resting heart rate of 48.25 was significantly higher than that in the intact fish. There was no evidence in the ECG of irregularity in the beat to beat interval as noted in the intact fish (fig. 16b).

Cardiac response to exercise was variable and even in cases where the resting heart rate was low the pattern of recovery after a test was erratic (Fig. 20). Training was apparently required in that one or two tests had to be carried out at low swimming speeds before the fish could sustain the higher speeds without occasionally falling back in the water flow. The maximum speed attained, 1.47 (V/L), was slightly lower than that in the intact individuals. Heart rates during swimming activity were significantly



Figure 21. Intact fish at 15°C. Heart rates during the course of three speed trials. Circles - 0.62 (V/L). Triangles - 1.14 (V/L). Squares 1.97 (V/L).



t rates  
speed  
L).  
ares 1.97 (V/L).

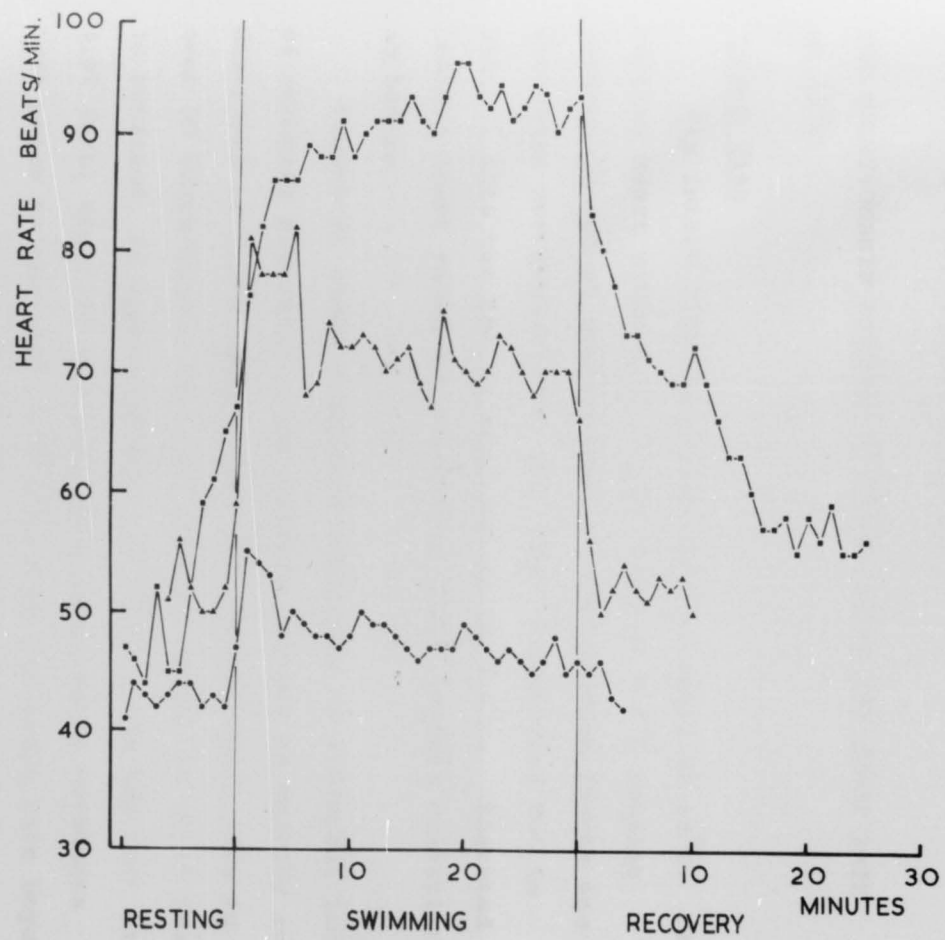

higher than at rest ( $P < .001$ ) but the correlation between heart rate and swimming speed was not significant and no coherent analysis could be made of recovery times or critical speeds. Thus the only line shown in fig. 18B is the mean resting heart rate.

THE RELATIONSHIP BETWEEN SWIMMING SPEED AND HEART RATE  
AT 15°C.

Intact fish

Six intact fish were subjected to tests at 15°C. The resting heart rates were higher than at 6.5°C ranging between 32 and 55 Beats/minute. The cardiac rhythm was irregular particularly at the lower frequencies but in general this was not as apparent as at 6.5°C. Elevated resting heart rates were observed under certain conditions as before.

Figure 21 shows 3 cardiac responses to different levels of swimming activity. The general pattern is exactly as described at 6.5°C except that the maximum heart rate is over 90 beats/minute and the critical speed, at which that is attained, is approximately 2.0 (V/L). In the test at 1.97 (V/L) the fish executed some spontaneous movements just prior to the test period so that the heart rate began to rise prematurely (Fig. 21). The steep increase in recovery times at 2.0 (V/L) is shown in figure 19c. The maximum time observed for complete recovery in heart rate from fatigue was 5½ hours.

Figure 22. 15°C. The relationships between heart rate and swimming speed. A - Intact fish. Open circles are data derived from unilaterally vagotomised fish inserted for comparison but not used in the calculation of the lines shown. B - Bivagotomised fish.

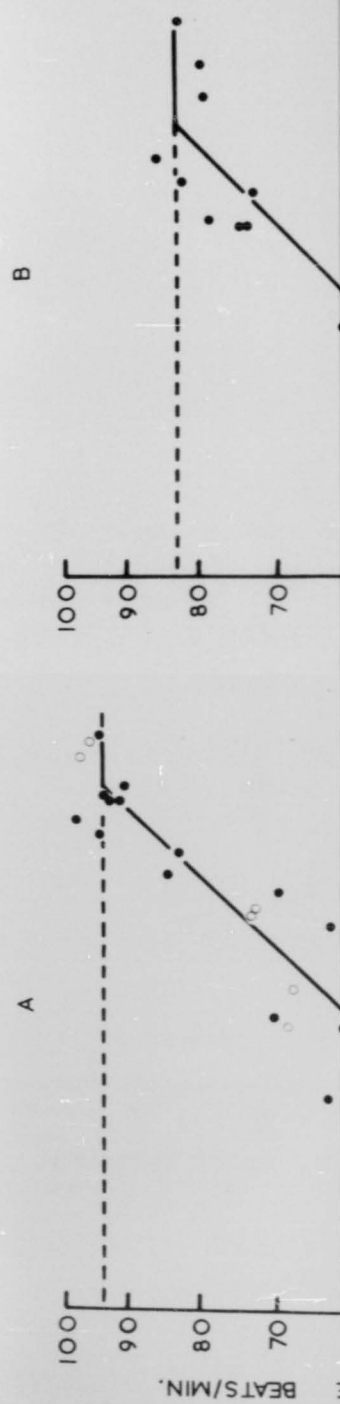

between heart  
A - Intact  
ta derived  
ed fish  
not used in  
s shown.

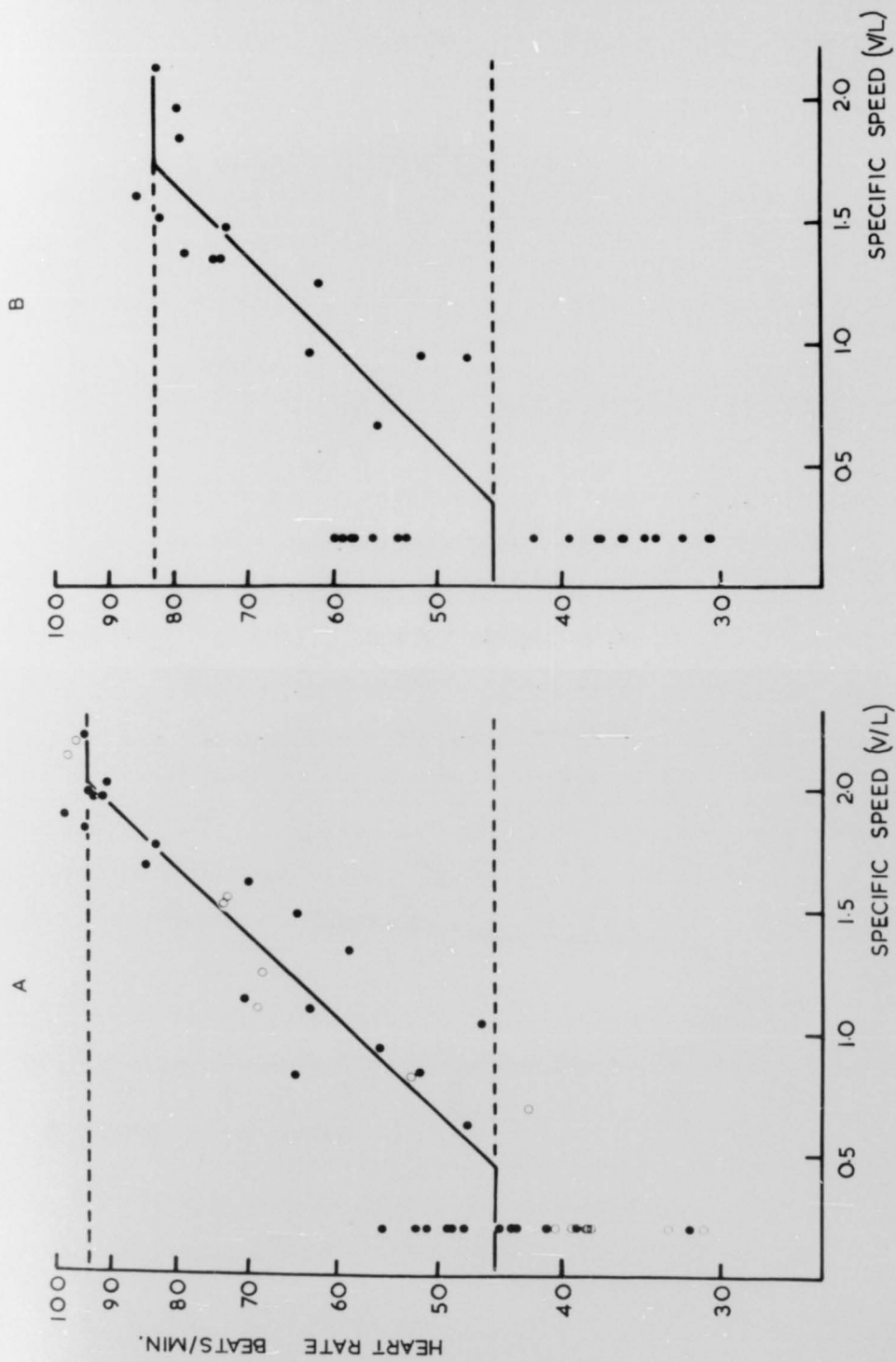

5/11

Figure 23. Bilaterally vagotomised fish at 15°C.  
Heart rates during the course of  
three speed trials. Circles -  
1.25 (V/L). Triangles - (V/L).  
Squares - 2.22 (V/L).

ART RATE BEATS/MIN  
08  
06  
001



h at 15°C.  
se of  
es -  
(L).

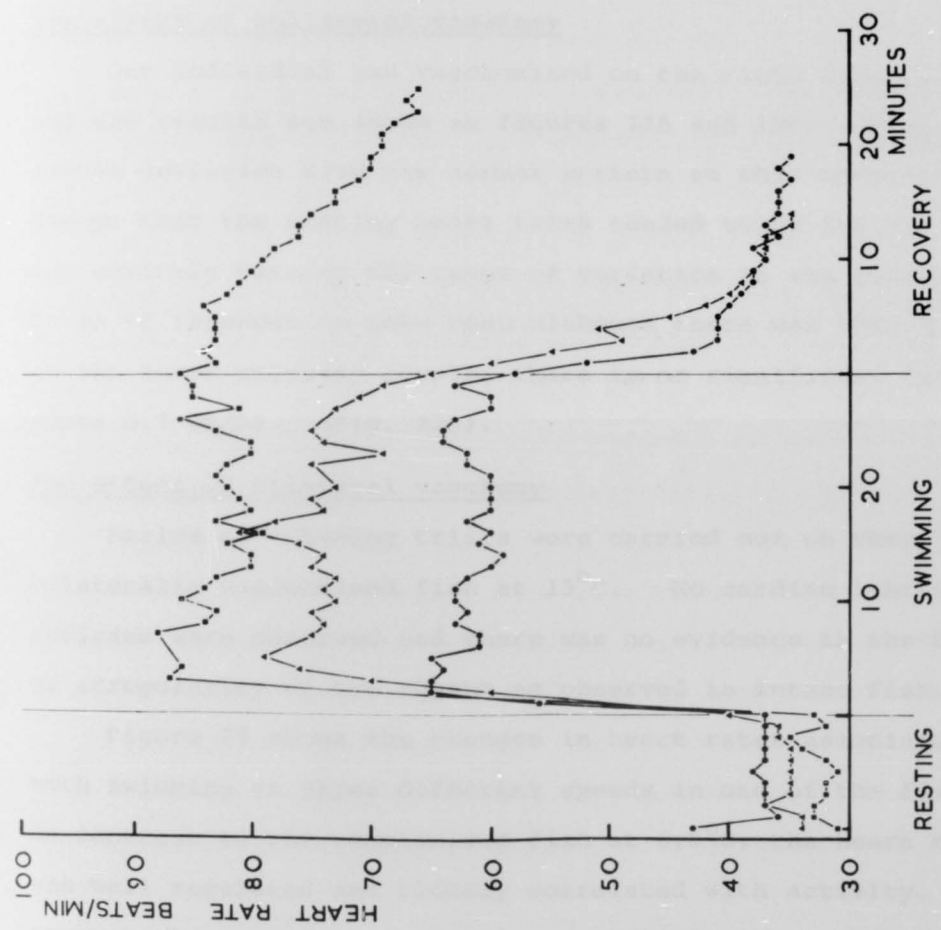

S/T

The relationship between heart rate and swimming speed was analysed as before and is shown in figure 22A. Despite large variations in resting heart rates the maximum frequencies are remarkably constant. The slope of the regression is not as steep as at  $6.5^{\circ}\text{C}$  (Table I).

#### The effect of unilateral vagotomy

One individual was vagotomised on the right side only and the results are shown in figures 22A and 19D. There was little deviation from the normal pattern at this temperature except that the resting heart rates tended to be low but were not entirely outside the range of variation in the intact fish. It is of interest to note that although there was this difference at the lower activity levels, there is no significant difference above 0.7 (V/L). (Fig. 22A).

#### The effect of bilateral vagotomy

Series of swimming trials were carried out on three bilaterally vagotomised fish at  $15^{\circ}\text{C}$ . No cardiac inhibitory reflexes were observed and there was no evidence in the ECG of irregularity of the rhythm as observed in intact fish.

Figure 23 shows the changes in heart rates associated with swimming at three different speeds in one of the fish. In contrast to the vagotomised fish at  $6.5^{\circ}\text{C}$ , the heart rate was well regulated and closely correlated with activity. However the mean maximum heart rate (83.88 beats per minute) was significantly lower than in the normals. The resting heart rate ranged from 31 to over 60 beats/minute, two fish having high resting frequencies and one a low resting rate. (Fig. 22B). The pattern of increase in recovery time at the critical speed of about 2.0 (V/L) was very close to that in normal fish. (Fig. 19e).



Thus the vagotomy did not have any significant effect at 15°C except that the maximum heart rate was depressed. This lowered maximum heart rate was further confirmed in two other vagotomised fish in which due to excessive spontaneous activity no reliable speed trials could be carried out.

#### CONCLUSIONS

At both 6.5°C and 15°C a general pattern of increase in heart rate with swimming speed was observed. These results will be discussed in detail in a general analysis of the relationship between heart rate and metabolism.

Unilateral vagotomy had no significant effect on heart rates during activity or on any cardiac response to stimuli. The significantly lower resting heart rates in unilaterally vagotomised fish at 15°C may be due to individual variation as heart rates of the same order were recorded in intact fish.

Bilateral vagotomy had distinctly different effects at the two temperatures. There was little effect on the general pattern of increase of heart rate with swimming speed at 15°C although cardiac inhibitory reflexes and associated periods of bradycardia were absent. At 15°C the maximum heart rates in bivagotomised fish were low. At 6.5°C the resting heart rates in bivagotomised fish were high and changes associated with swimming did not appear to be well regulated.

#### The effects of Feeding on Heart rate

##### INTRODUCTION

In the speed trials it was found that due to excitement or spontaneous activity of the fish high resting heart rates were often recorded in some fish. These were excluded from the analysis of the heart rate/swimming speed relationship.

Figure 24. 15°C. The relationship between heart rate and swimming speed in recently fed and starved fish compared with the normal group of intact fish at this temperature.

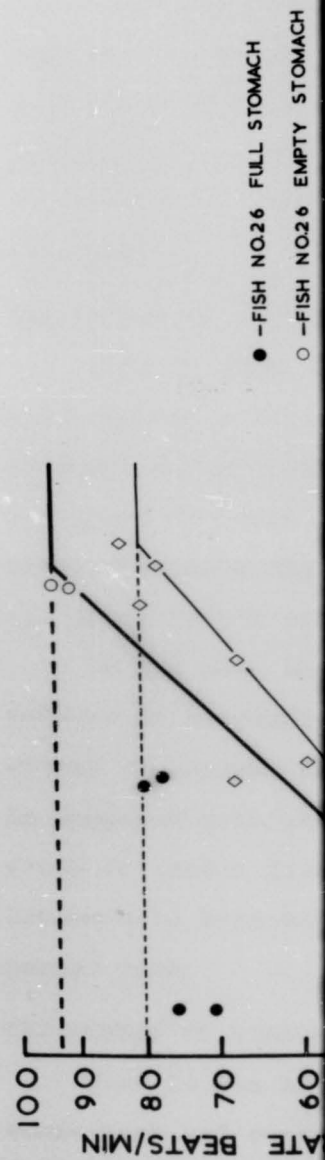

between heart  
recently fed  
with the normal  
temperature.

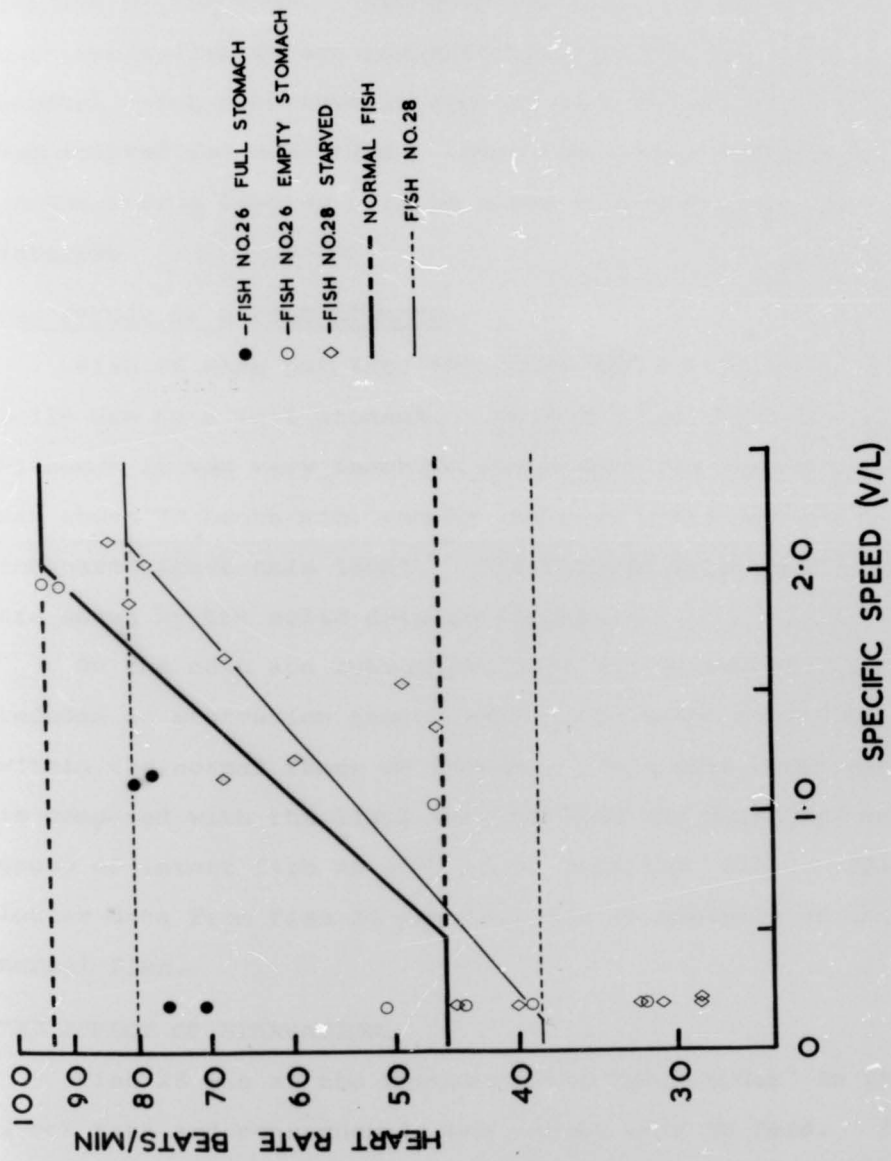

In some cases consistently abnormally high or low heart rates could be definitely attributed to the state of feeding of the fish. Two such cases for which sufficient data was collected are presented here; one fish with a full stomach which subsequently emptied and another fish which had starved for some time. Also the events occurring in an ECG during feeding will be shown as a related point of interest.

#### THE EFFECT OF A FULL STOMACH.

Fish 26 when put into the flume had an obviously distended belly due to a full stomach. On the first experimental day although it was very inactive and sedate its resting heart rate was above 70 beats/min. and in swimming tests the heart rate increased above this level. The results from this first day are shown by the solid dots in figure 24.

On the next and subsequent days its distended belly receded as starvation proceeded and the heart rate fell to within the normal range of values. This data (open circles) is compared with the lines derived from the main experimental group of intact fish at 15°C (i.e. from fig. 22A). This latter data from fish 26 was included in analysis on intact normal fish.

#### THE EFFECT OF STARVATION.

Fish 28 was at the bottom of the "peck order" in the stock tank and consequently was rarely able to feed. Its condition factor was 0.95 and analysis of lipid content of the tissue carried out by Mr. M.G. McLeod (Dept. of Biology, University of Stirling) indicated a condition equivalent to a

Figure 25. ECG during feeding in the flume test chamber. The fish took one floating food pellet at the point indicated.

E.C.G. DURING FEEDING ( FISH 27 15°C )

## E.C.G. DURING FEEDING ( FISH 27 15°C )

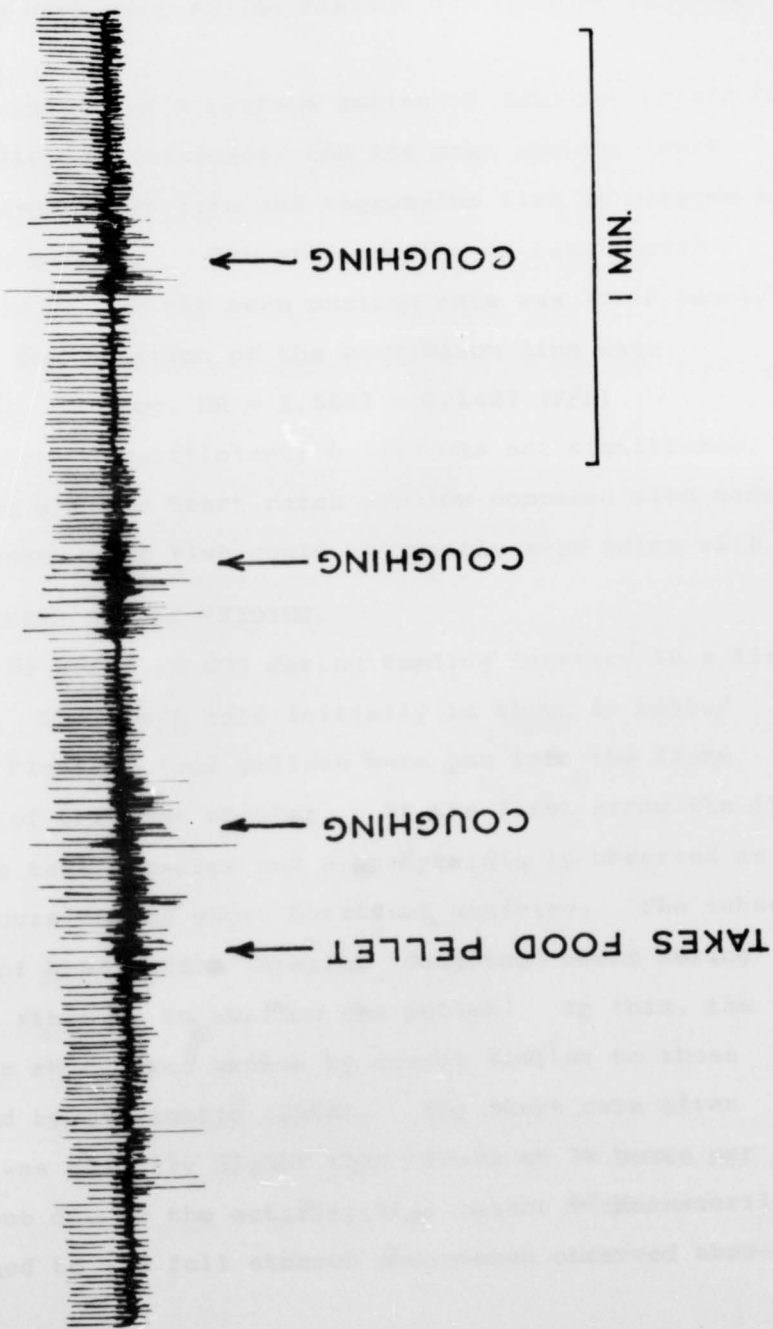

period of starvation of several weeks. Its general appearance with many scales missing and damaged fins was poor.

The results of a routine series of swimming trials is shown in fig. 24 (Diamonds) and the mean resting heart rate, maximum heart rate and regression line in between are plotted as before. The mean resting or basal heart rate was 38.28 and the mean maximum rate was 79.67 beats/minute. The equation of the regression line was:

$$\text{Log. HR} = 1.5657 + 0.1427 (V/L)$$

The correlation coefficient; 0.5412 was not significant. In general all the heart rates are low compared with normal fish although this fish could apparently swim quite well.

#### ECG PHENOMENA DURING FEEDING.

Fig 25 shows an ECG during feeding activity in a fish at 15°C. The heart rate initially is about 60 beats/minute. Floating food pellets were put into the flume upstream of the test chamber. At the first arrow the fish "rose" to take a pellet and a bradycardia is observed as often occurs during short bursts of activity. The subsequent periods of bradycardia labelled "coughing" occur during apparent attempts to swallow the pellet. In this, the opercular rhythm was broken by coughs similar to those described by Ballintijn (1969). The heart rate after feeding was slightly higher than before at 70 beats per minute but due to the activity this cannot be necessarily attributed to the full stomach phenomenon observed above.

Oxygen Consumption and Heart Rate Measurements

In the course of investigation of the relationship between heart rate and swimming speed elevated heart rates were often observed when the fish was at rest. It was assumed generally that this was attributable to the effects of a full stomach, recovery from activity, or other effects which might be likely to cause an elevated oxygen consumption. Also much of the analysis of the heart rate-activity studies implicitly assumes a uniform relationship between heart rate and oxygen consumption. The investigation in this section was proposed in order to test these assumptions.

RESULTS.

Measurements of oxygen consumption and heart rate were carried out on 6 rainbow trout at 15°C. The details of the fish, oxygen consumptions and mean heart rates are given appendix II. The logarithms of heart rate and oxygen consumption are plotted graphically in figure 26 and a calculated regression line (solid line) is drawn through the points. The equation of line was:-

$$\text{LogHR} = 0.4393 \text{ LogO}_2 + 0.8171$$

The correlation coefficient was 0.7788 which with n=46 is highly significant at the .001% level.

Also in figure 26 are shown two dotted lines which were calculated using the heart rate swimming speed relationship already derived (table I) and oxygen consumption - swimming speed relationships given in the literature. Two different sets of data were used. Webb (1971 b) measured O<sub>2</sub> consumption



Figure 26. The relationship between heart rate and oxygen consumption. The results of individual fish are plotted and a calculated overall regression line is drawn through the points (solid line). The dotted lines are "predicted" forms for this relationship using oxygen consumption data from the literature in conjunction with the heart rate-swimming speed data in this study.



art rate and  
results of  
and a  
on line is  
olid line).  
cted" forms  
oxygen  
iterature  
rt rate-  
study.

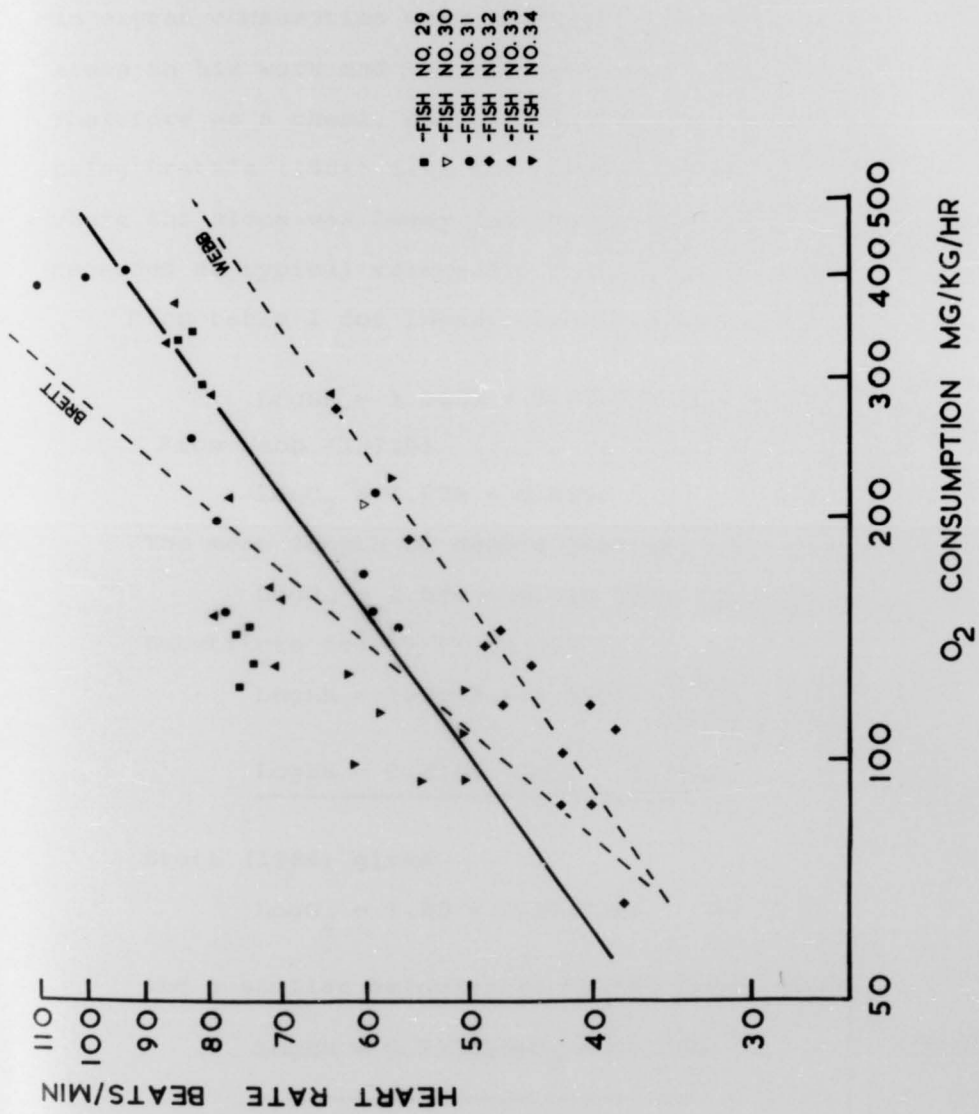

in rainbow trout from what is probably a very similar stock to that used in this work. However the slopes of increase in oxygen consumption with swimming speed are unusually steep in his work and the critical swimming speeds were low. Therefore as a check, calculations were also carried out using Brett's (1964) data for Onchorhynchus nerka at 15°C where the slope was lower and closer to what has come to be regarded as typical values for fish. (Tytler 1969).

From table I for intact rainbow trout at 15°C :

$$\text{LogHR} = 1.5639 + 0.1937 (V/L) \quad (1)$$

From Webb (1971b)

$$\text{LogO}_2 = 1.878 + 0.016V \quad (2)$$

The mean length of Webb's fish was 29.2 cm. Therefore

$$\text{LogO}_2 = 1.878 + 0.016 (V/L) 29.2$$

Substitute for (V/L) in (1)

$$\text{LogHR} = 1.5639 + 0.1937 \frac{\text{LogO}_2 - 1.878}{0.016 \times 29.2}$$

$$\underline{\text{LogHR} = 0.4146 \text{LogO}_2 + 0.7852} \quad (\text{Webb})$$

Brett (1964) gives

$$\text{LogO}_2 = 1.85 + 0.27 (V/L) \quad \text{at } 15^\circ\text{C}$$

and a similar calculation to the above gives

$$\underline{\text{LogHR} = 0.7174 \text{LogO}_2 + 0.2365} \quad (\text{Brett})$$

A statistical analysis was made of the variance ratio in order to determine whether there is any significant difference between these two "predicted" lines and the actual O<sub>2</sub>-HR relationship obtained. In order to carry this out the swimming speed values for the 15°C HR - (V/L) relationship were transformed

Figure 27. The data from figure 26 is shown with the limits on the oxygen consumption and heart rate inserted for comparison. The irregular quadrangle to the left of the dotted line within which most of the data points lie is termed "The quadrangle of scope".

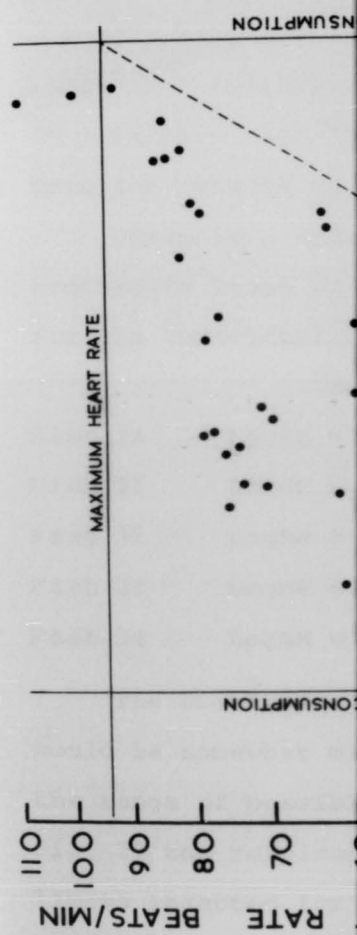

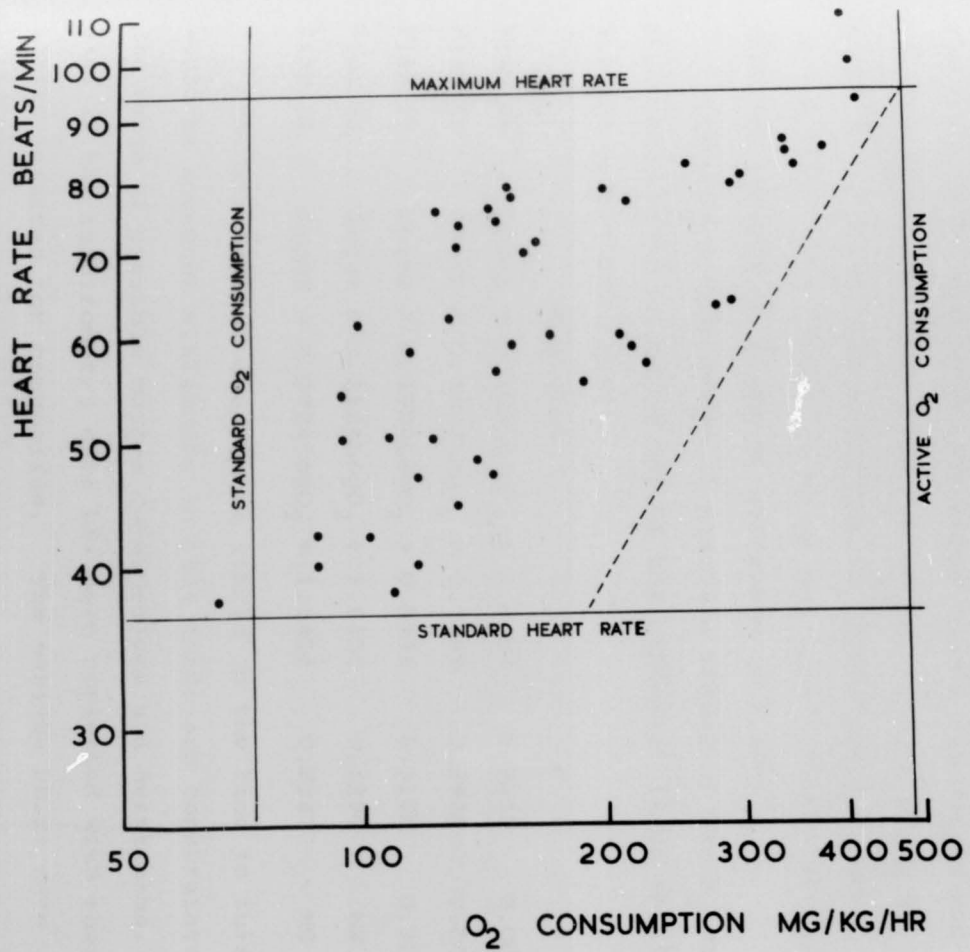

shown with  
 assumption  
 comparison.  
 the left  
 which most  
 aimed

into the corresponding oxygen consumptions using either the above "Webb" or "Brett" equations. The resulting transformed sums, squares etc. of X and Y values could be used in a standard analysis of covariance of two regressions calculation (F test) for comparison with the actual experimental results. The predicted line using Webb's figures is not significantly different from the actual line in terms of slope ( $P > 10\%$ ) but its elevation is significantly lower ( $P < 0.1\%$ ). The "Brett" line is not significantly different from the results in slope or elevation ( $P > 10\%$ ).

There is a wide range of possible slopes of the  $O_2$  HR regression lines as borne out by the different lines obtained for the individual fish:-

	Equation	r	P
Fish 29	$\text{LogHR} = 0.1091\text{LogO}_2 + 1.6397$	0.9233	0.001
Fish 31	$\text{LogHR} = 0.4807\text{LogO}_2 + 0.7389$	0.8539	0.001
Fish 32	$\text{LogHR} = 0.3704\text{LogO}_2 + 0.8796$	0.9158	0.001
Fish 33	$\text{LogHR} = 0.1124\text{LogO}_2 + 1.6125$	0.4530	NS
Fish 34	$\text{LogHR} = 0.0724\text{LogO}_2 + 1.5924$	0.2247	NS

The statistical confidence limits on the line in this case would be somewhat misleading in that there are constraints on the range of possible oxygen consumptions and heart rates. In fig. 27 the respirometry data has been replotted with these limits inserted for comparison. The maximum heart rate (93.76 beats/min) is the figure obtained from the intact group of fish in the swimming experiments at  $15^\circ\text{C}$  (Table I). The standard heart rate (36.64 beats/min.) is the heart rate obtained by extrapolating the active heart rate regression line to zero swimming speed (i.e. the antilogarithm of the regression

constant in equation (1) above). By analogy with the methods used for determination of standard oxygen consumption (Fry 1957) this represents the lowest possible heart rate in a resting fish. The standard oxygen consumption (72.5 mg/kg/hr) and the active oxygen consumption (480.0mg/kg/hr) are taken from Webb (1971b).

For any given heart rate there must be a maximum possible oxygen consumption which occurs when the cardiac stroke volume and the oxygen carrying capacity of the blood are both at a maximum (i.e. maximum  $O_2$  pulse). It was assumed that at maximum heart rate and active (maximum) oxygen consumption these optimal conditions were in existence. Thus a line could be plotted through this point which denotes the maximum oxygen consumption for any given heart rate:

$$O_2 \text{ consumption} \propto HR \quad (\text{if } O_2 \text{ pulse is constant at its maximum value})$$

In this case  $O_2$  consumption = 5.1195 HR.

From these basic considerations it can be seen that all the heart rate/oxygen consumption points should lie within the irregular quadrangle to the left of the dotted line figure 27. It is also probable that at high heart rates the oxygen consumptions by the myocardium would be elevated. This would mean that as heart rate increases so the minimum possible oxygen consumption by the fish must be above the standard oxygen consumption. This effect could not be quantified precisely but is probably small (Webb 1970) and has been omitted from the diagram.

In general the points fall within the quadrangle with the notable exception of two high heart rates (fish 31). This fish subsequently died from some unknown cause possibly the

effects of stress. Despite the varied conditions under which these fish were tested (active, resting, full stomach, empty stomach etc.) the points are not scattered throughout the available area. It seems that some optimization of performance may have taken place tending to aggregate the points along the diagonal of the quadrangle. In actual fact the diagonal is probably a good approximation to the heart rate/oxygen consumption relationship.

No correlation was noted between high or low heart rates and particular aspects of the fishes behaviour or any other phenomena.

#### Auxiliary Circulatory Pumps - Structure and Function

Any mechanism which could act as a pump tending to increase blood flow or pressure independently of the heart could have a profound effect on the functional characteristics of the circulatory system. This section of the thesis is devoted to an investigation of the structure and possible function of such mechanisms in rainbow trout.

#### LYMPH PROPULSORS.

A detailed anatomical account of the lymph system was outside the scope of the present study but measurements were taken of the diameters of the major lymph vessels in the trunk and tail regions from transverse sections through a 23 cm long fish:-

- lymphaticus lateralis - 0.2 mm
- lymphaticus caudalis - 0.3 mm
- lymphaticus dorsalis - 0.2 mm
- lymphaticus cardinalis - 0.15 mm

These are mean diameters as some of the vessels are elliptical in cross section.



Figure 28. Lateral view of the bones of the tail of rainbow trout showing the foramen hypurale through which the two chambers of the lymph heart are interconnected. Osteological terminology from Norden (1961). CFR - caudal fin ray, E - Epural, EHS - expanded haemal spine, ENS - expanded neural spine, H - hypural, U - Uroneural.

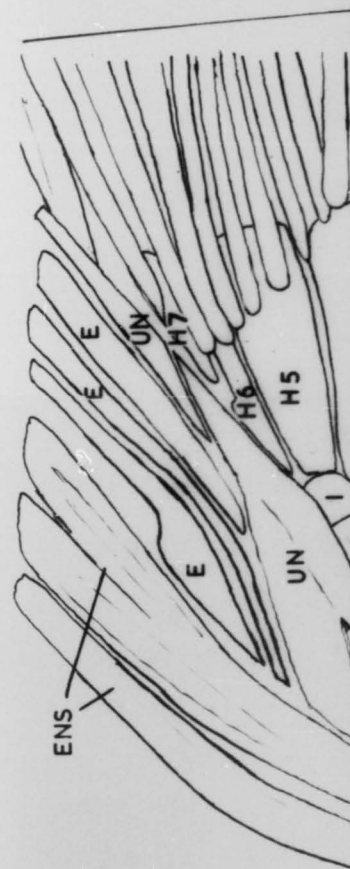

f the tail of  
oramen  
two chambers  
rconnected.  
om Norden  
ray, E -  
al spine,  
, H -

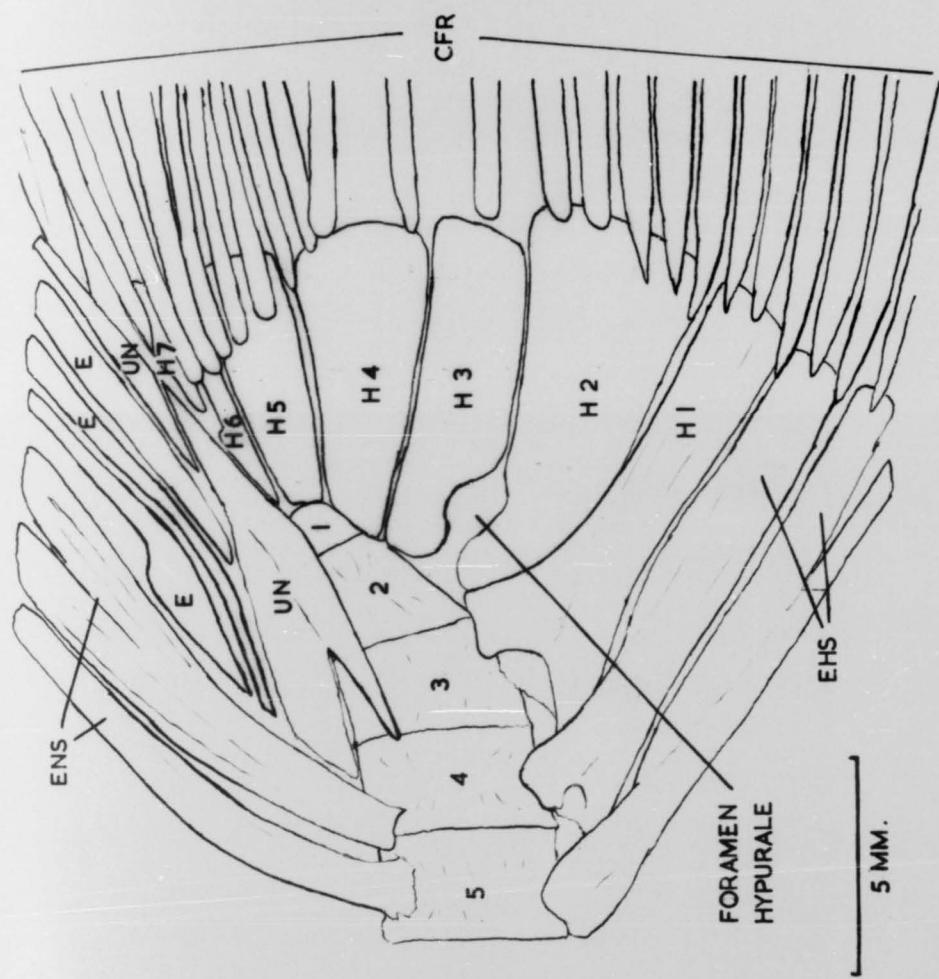
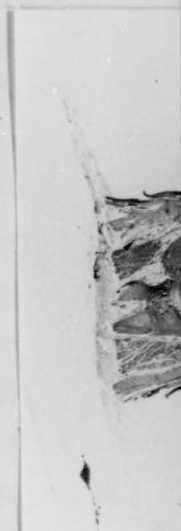

Figure 29. Horizontal longitudinal section through the caudal lymph heart (haematoxylin and eosin). CFM - caudal flexor muscle. CV - caudal vertebra, FH - foramen hypurale, H-hypural bone, LHC - lymph heart chambers.

Figure 30. Transverse section through the haemal canal in the caudal region. (Haematoxylin and eosin). C - centrum of vertebra, CA - caudal artery (injected with carbon/agar for positive identification), CL - caudal lymphatic, CV - caudal vein, HA - haemal arch, X - musculature cut away to allow penetration of the decalcifying fluid.



ection through  
ematoxylin and  
or muscle. CV -  
men hypurale,  
h heart

the haemal  
(Haematoxylin  
f vertebra,  
ed with carbon/  
cation),  
caudal vein,  
alature cut  
of the

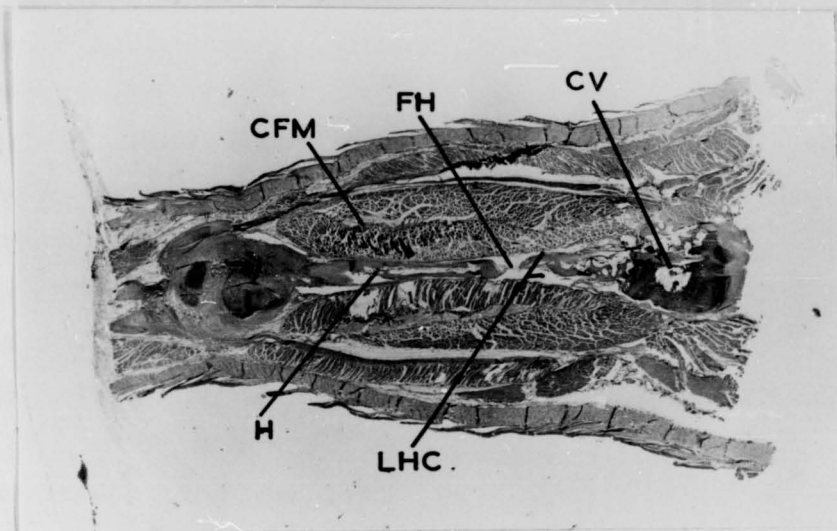

The anatomy of the caudal lymph heart was also investigated. Figure 28 shows the bones of the tail of rainbow trout with the foramen hypurale between the hypural bones through which the two chambers of the lymph heart are interconnected. The lymph heart consists of two small flattened sacs (about 2mm across in a 30cm fish) which lie on either side of the hypural bones below the end of the vertebral column. Figure 29 shows a longitudinal section through in the horizontal plane this region of the fish showing the two chambers and their interconnection. There is no specialised myocardium and the only musculature associated with the heart is that of the caudal fin. No independent pulsation of the heart was noticed. It is probable that any pumping action of the caudal lymph heart is due to the movement of the extrinsic muscles of the caudal fin and that during swimming activity the pumping would be of the same frequency as the tail beat frequency.

The volume of each chamber of the caudal heart was estimated from silicone rubber casts from a 30 cm fish at approximately 0.002ml.

In the caudal region below the vertebral column there is a caudal lymphatic vessel running ventral to the caudal vein and artery (fig 30). The caudal lymph heart appears to be connected to this and lymph probably flows from the lymph heart along the caudal lymphatic into the cardinal lymphatics to drain into the major veins close to the heart. However several complex connections with the caudal lymph heart were noted and the possibility of a direct flow of lymph into the caudal vein could not be excluded.

The lymph vessels are generally an order of magnitude smaller than the corresponding blood vessels so that as high pressures are unlikely in the lymph system the flow rates are probably small in comparison with blood flow.

Kampmeier (1969) reviews the literature on lymph systems of fish and suggests that an independently pulsatile caudal lymph heart is only found in eels and similar fish. Hyrtl (1843) observed no independent pulsations of the caudal lymph heart of trout which is confirmed by the present observations. However Grodzinski (1959) who studied the development of the caudal heart in sea trout observed rhythmic contractions of the chambers. It is probable that these independent pulsations do not continue in the adult. The close proximity of the caudal skeleton and musculature would preclude any really effective pulsations independent of the tail movements. Grodzinski also clearly shows that the caudal lymph heart empties directly into the caudal vein and does not indicate the presence of a caudal lymphatic. The silicone rubber injection mass used was too viscous for entirely satisfactory study of the delicate lymph vessels but definite points of difference from the sea trout embryo emerged particularly with respect to the caudal lymphatic.

From the functional point of view it can be stated in conclusion that the caudal lymph heart pumps per tail beat approximately 0.002ml of lymph ultimately into the venous system by a pathway which is as yet uncertain. The output at different swimming speeds can be calculated by simple multiplication of the volume by tail beat frequency using the swimming data of Bainbridge (1958). This predicted output is plotted against

swimming speed in fig 41 and compared with the cardiac output estimates of Stevens & Randall (1967b). It can be seen that the caudal lymph heart output is considerably smaller than the overall blood flow.

#### DORSAL AORTA LIGAMENT.

##### Anatomy

From the dissections of rainbow trout it was found that the position and connections of the dorsal aorta with other blood vessels are exactly as described by Gorkiewicz (1947) and Sikorawa (1947). However the uniform cylindrical form of the aorta as represented by these authors is a simplification.

Figure 31 shows a general view of the dorsal aorta as dissected from the ventral aspect. It lies on the ventral surface of the vertebral column dorsal to the kidney in the trunk region. It continues in the caudal region inside the haemal arches of the vertebrae, dorsal to the caudal vein. The aorta is flattened dorso-ventrally in the trunk region and narrows in width towards the tail where it becomes almost circular in cross section. Detailed measurements of diameters of the silicone rubber casts are shown in figure 32. The depth of the vessel is quite uniform throughout most of its length.

Figure 33 shows a cross section of the aorta in the trunk region and shows the ligament, with its attached "mesentery" or curtain. Staining with orcein (fig 34) shows that there are elastic fibres in the wall of the aorta but its distensibility is confined by the vertebrae and the kidney. It can also be seen that the ligament is rich in elastic fibres. The

Figure 31. General view of a dissection of the dorsal aorta from the ventral aspect showing the longitudinal ligament in situ. Efferent branchial arteries in the cranial region join the aorta which runs down the length of the body. The segmental arteries are not shown.

10 mm



ion of the dorsal  
pect showing the  
situ. Efferent  
cranial region  
down the length  
tal arteries



RAINBOW TROUT  
DORSAL AORTA

Figure 32. Measurements of width and depth of the dorsal aorta of a fish 18cm long. Measurements were taken at 5mm intervals along the length of a silicone rubber cast of the aorta from the point of anchorage of the ligament (0mm) to well into the caudal region. The width multiplied by depth gives an estimate change in cross sectional area.

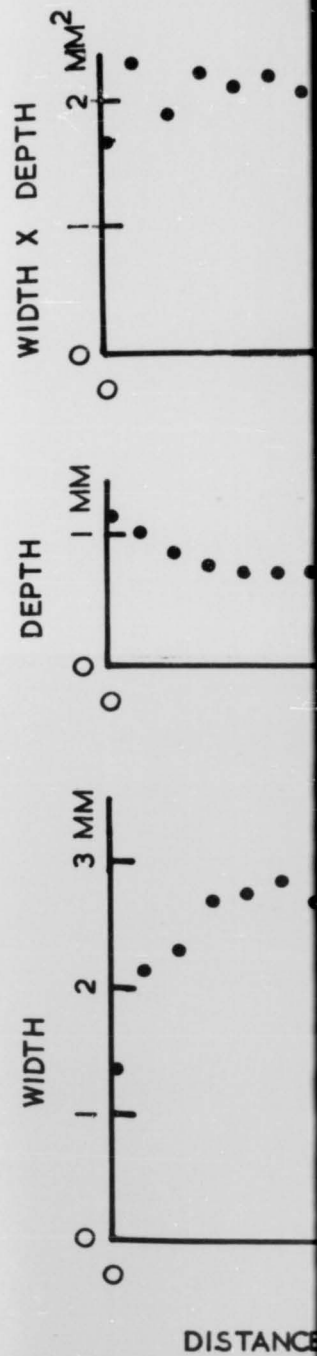

depth of the  
cm long.  
t 5mm intervals  
econ rubber  
e point of  
(0mm) to  
on. The  
gives an  
sectional

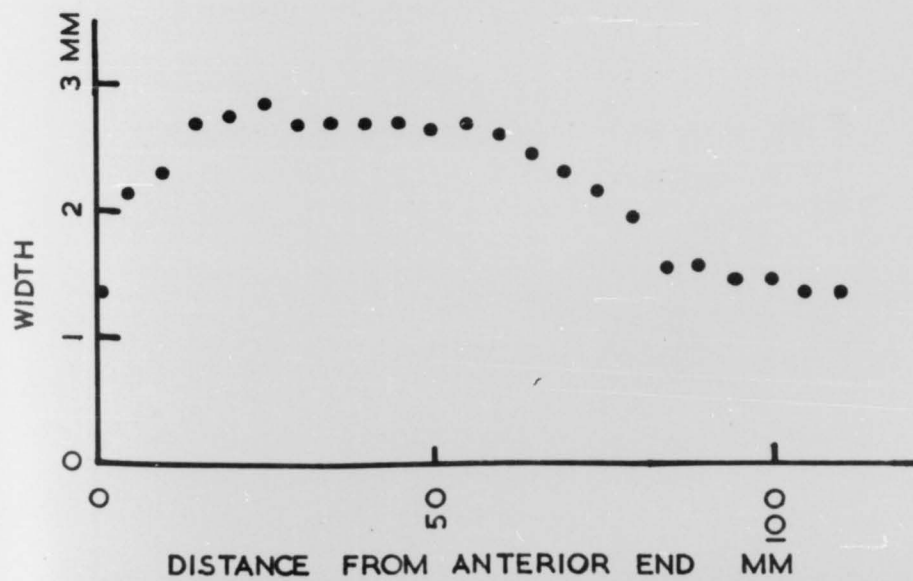
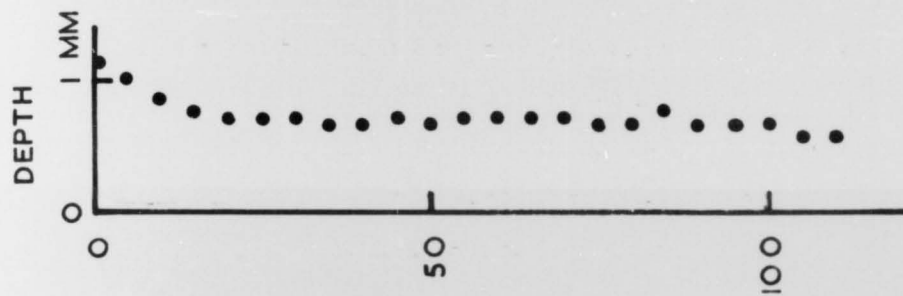
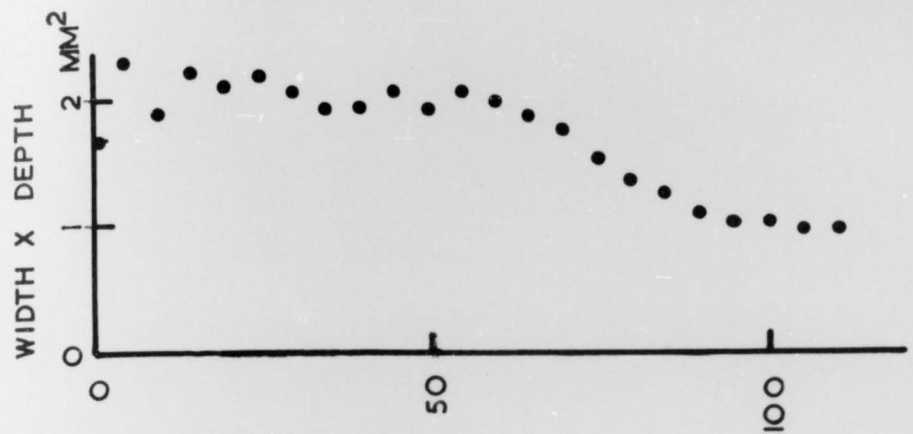
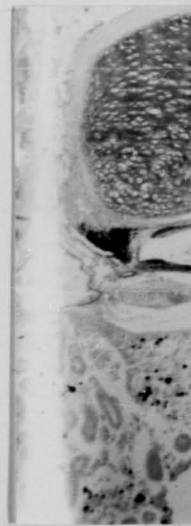

Figure 33. Transverse section through the vertebral column and dorsal aorta in the trunk region (haematoxylin and eosin). C - centrum, DA - dorsal aorta, DLL - dorsal longitudinal ligament, M - muscle, NA - neural arch, P - parapophysis, PCV - posterior cardinal vein, VLL - ventral longitudinal ligament (dorsal aorta ligament).

Figure 34. Transverse section of the dorsal aorta (orcein elastica). The orcein has selectively stained the elastic elements in the wall of the aorta and in the longitudinal ligament. Abbreviations as for fig. 33.

M  
NA

DA  
PCV



h the vertebral  
 n the trunk  
 eosin). C -  
 a, DLL - dorsal  
 - muscle, NA -  
 ysis, PCV -  
 VLL - ventral  
 rsal aorta

dorsal aorta  
 orcein has  
 lastic elements  
 and in the  
 reviations

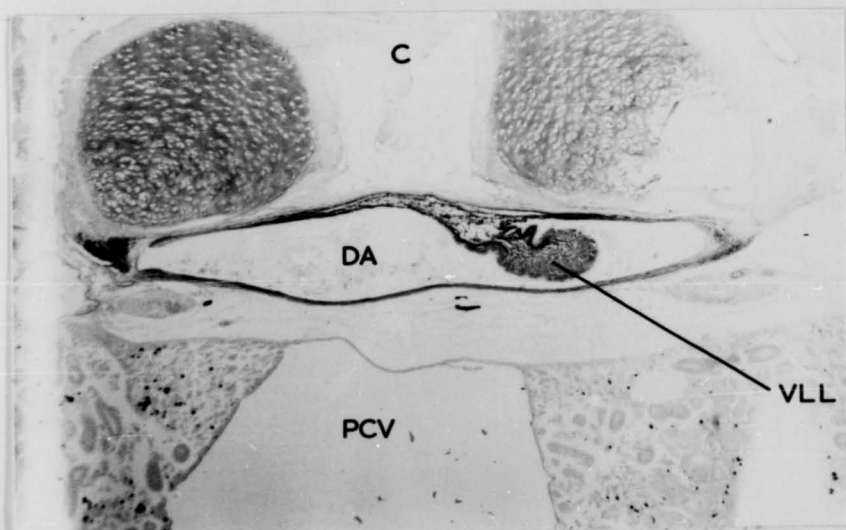
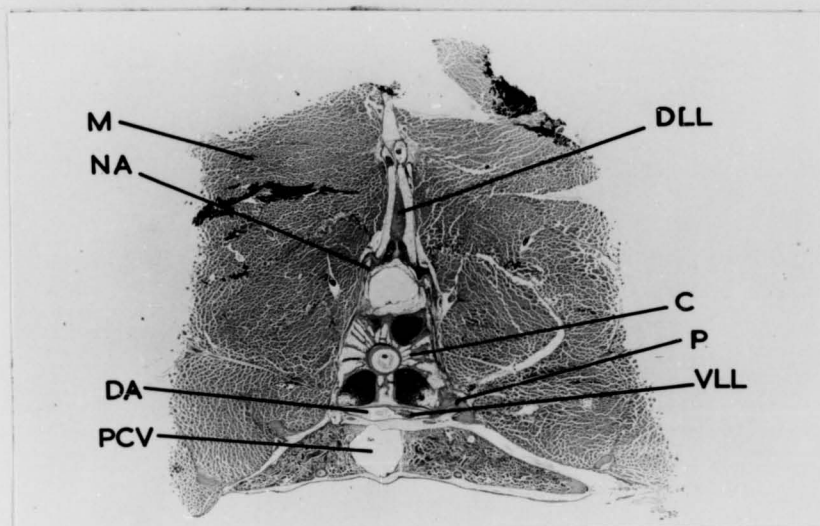

PL

S/T

Figure 35. Anterior end of a cast of the dorsal aorta and the efferent branchial arteries. Side elevation of the right side. 1,2,3,4 - efferent branchial arteries, CM - coeliacomesenteric artery, DA - dorsal aorta, DS - dorsal segmental artery, IC - internal carotid artery, ICA - intercostal artery, LA - lateral aorta, LS - lateral segmental artery, S - subclavian artery, X - point of anchorage of the aortic ligament to the basioccipital bone.



f the dorsal  
 ranchial arteries.  
 ght side. 1,2,3,4 -  
 ies, CM - coeliaco-  
 dorsal aorta,  
 erty, IC - internal  
 tercostal artery,  
 lateral segmental  
 erty, X - point  
 ic ligament to the

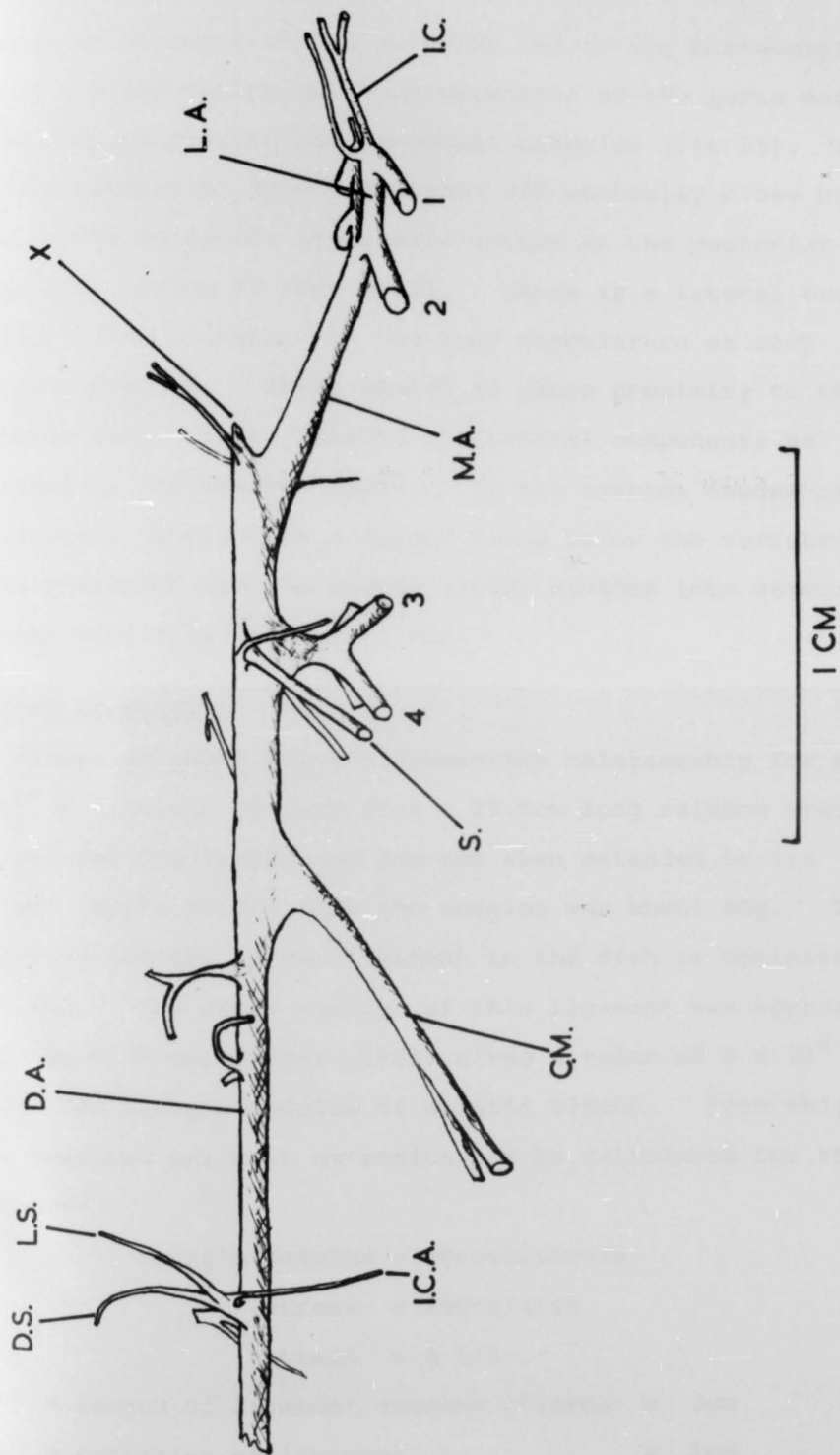
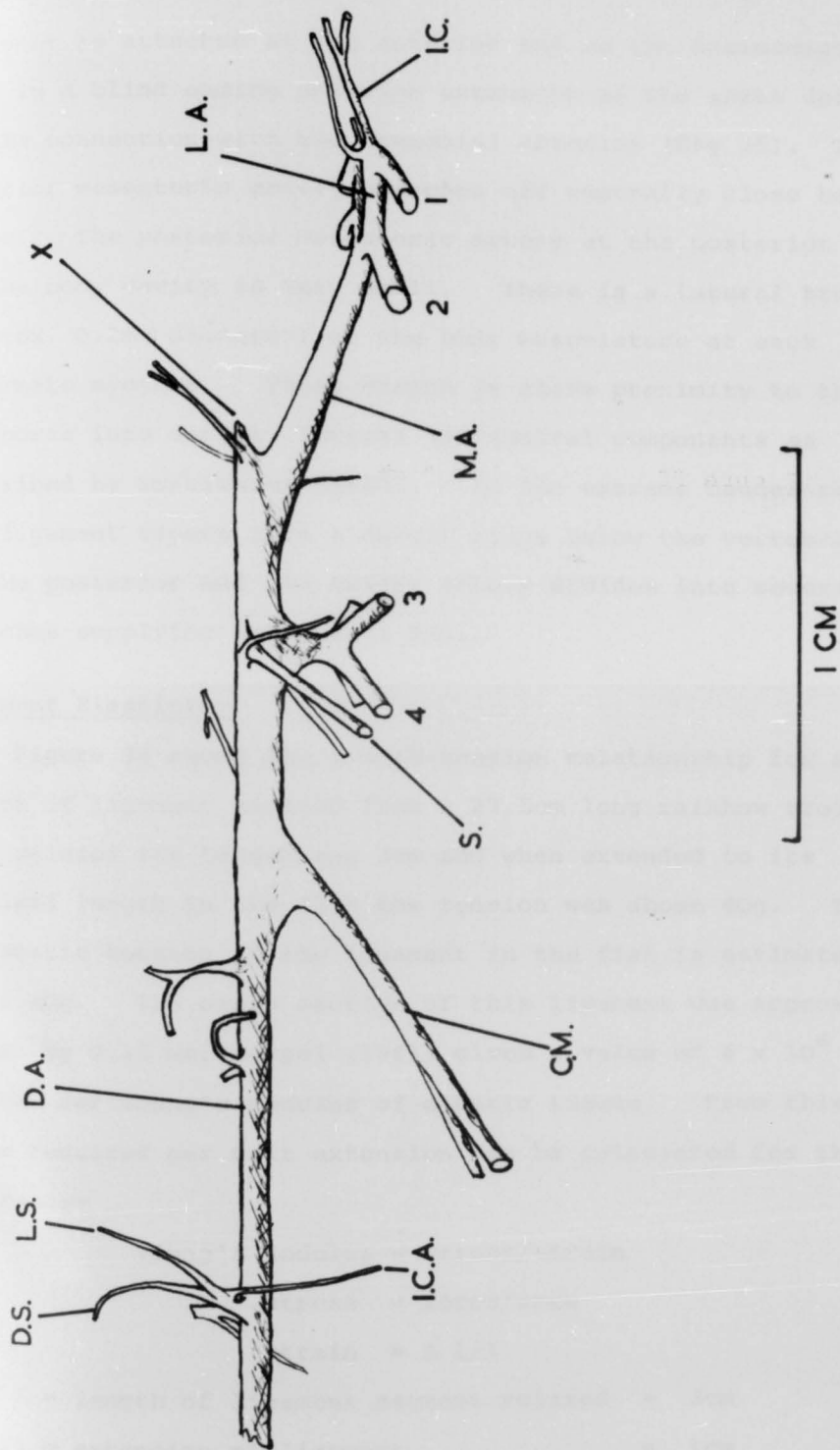

Figure 35. Anterior end of a cast of the dorsal aorta and the efferent branchial arteries. Side elevation of the right side. 1,2,3,4 - efferent branchial arteries, CM - coeliacomesenteric artery, DA - dorsal aorta, DS - dorsal segmental artery, IC - internal carotid artery, ICA - intercostal artery, LA - lateral aorta, LS - lateral segmental artery, S - subclavian artery, X - point of anchorage of the aortic ligament to the basioccipital bone.





the dorsal  
 branchial arteries.  
 right side. 1,2,3,4 -  
 es, CM - coeliaco-  
 dorsal aorta,  
 ery, IC - internal  
 ercostal artery,  
 lateral segmental  
 tery, X - point  
 c ligament to the



ligament is attached at its anterior end to the basioccipital bone in a blind ending anterior extension of the aorta dorsal to the connection with the branchial arteries (fig 35). The anterior mesenteric artery branches off ventrally close behind this point. The posterior mesenteric artery at the posterior end of the body cavity is very small. There is a lateral branch (approx. 0.2mm diameter) to the body musculature at each alternate myotome. These branch in close proximity to the vertebrae into dorsal, lateral and ventral components as described by Gorkiewicz (1947). In the extreme caudal region the ligament tapers into a dorsal ridge below the vertebrae. At the posterior end the caudal artery divides into several branches supplying the caudal fin.

#### Ligament Elasticity

Figure 36 shows the length-tension relationship for a 5cm length of ligament excised from a 27.5cm long rainbow trout. When relaxed its length was 3cm and when extended to its original length in the fish the tension was about 40g. Thus the static tension in the ligament in the fish is estimated as about 40g. The cross section of this ligament was approximately 0.75mm by 0.15 mm. Bergel (1961) gives a value of  $6 \times 10^6$  dyn/cm<sup>2</sup> for Young's modulus of elastic tissue. From this the force required per unit extension can be calculated for this ligament:-

$$\text{Young's Modulus} = \text{stress/strain}$$

$$\text{stress} = \text{force/area}$$

$$\text{strain} = \Delta l/l$$

$$l = \text{length of ligament segment relaxed} = 3\text{cm}$$

$$\Delta l = \text{extension of ligament} = 1\text{cm}$$

ligament is attached at its anterior end to the basioccipital bone in a blind ending anterior extension of the aorta dorsal to the connection with the branchial arteries (fig 35). The anterior mesenteric artery branches off ventrally close behind this point. The posterior mesenteric artery at the posterior end of the body cavity is very small. There is a lateral branch (approx. 0.2mm diameter) to the body musculature at each alternate myotome. These branch in close proximity to the vertebrae into dorsal, lateral and ventral components as described by Gorkiewicz (1947). In the extreme caudal region the ligament tapers into a dorsal ridge below the vertebrae. At the posterior end the caudal artery divides into several branches supplying the caudal fin.

#### Ligament Elasticity

Figure 36 shows the length-tension relationship for a 5cm length of ligament excised from a 27.5cm long rainbow trout. When relaxed its length was 3cm and when extended to its original length in the fish the tension was about 40g. Thus the static tension in the ligament in the fish is estimated as about 40g. The cross section of this ligament was approximately 0.75mm by 0.15 mm. Bergel (1961) gives a value of  $6 \times 10^6$  dyn/cm<sup>2</sup> for Young's modulus of elastic tissue. From this the force required per unit extension can be calculated for this ligament:-

$$\text{Young's Modulus} = \text{stress/strain}$$

$$\text{stress} = \text{force/area}$$

$$\text{strain} = \Delta l/l$$

$$l = \text{length of ligament segment relaxed} = 3\text{cm}$$

$$\Delta l = \text{extension of ligament} = 1\text{cm}$$

Figure 36. The length-tension relationship in a segment of the dorsal aorta ligament which was 5cm long in situ in the fish. The straight line is the theoretical relationship assuming that Hook's law is obeyed.

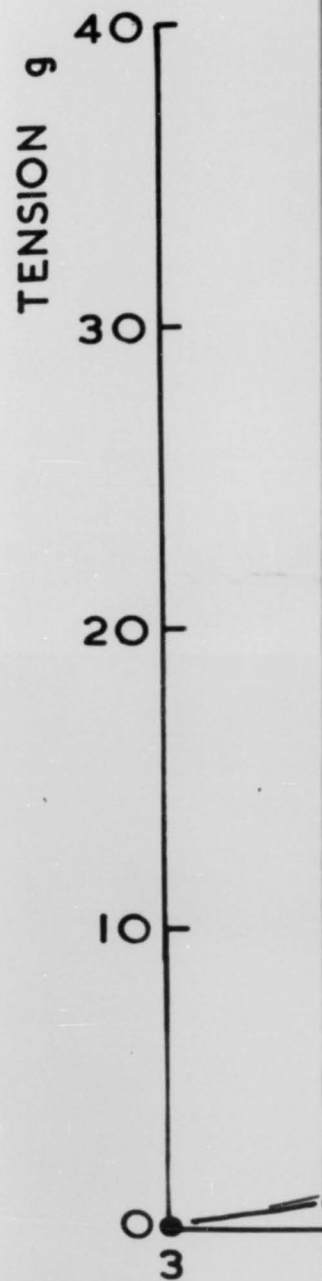

nship in a  
a ligament which  
e fish. The  
etical  
Hook's law

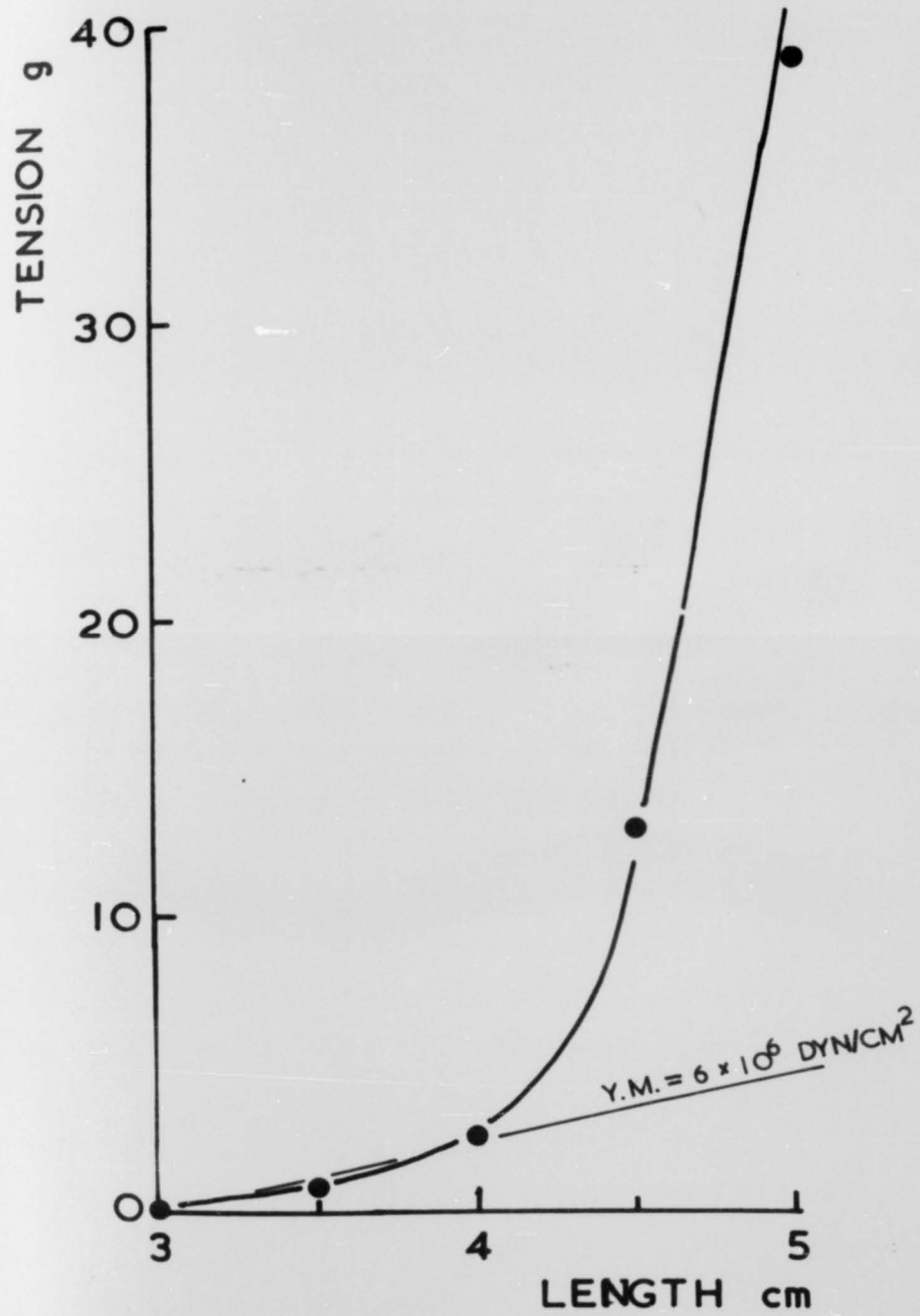

PL

S  
T

Figure 37. Function of the dorsal aorta ligament  
(After Burne 1909). In these plan  
views the arrows indicate the direction  
of movement of the swimming waves  
along the body. Blood is enclosed  
in alternate compartments on either  
side of the ligament and is carried  
caudad with the wave movement.

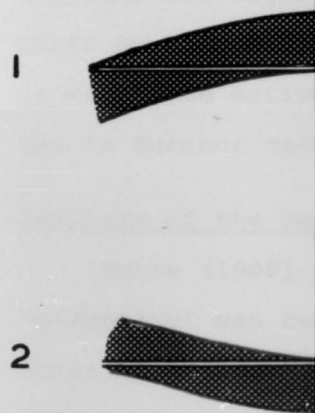

aorta ligament  
these plan  
the direction  
ng waves  
s enclosed  
on either  
is carried  
ment.

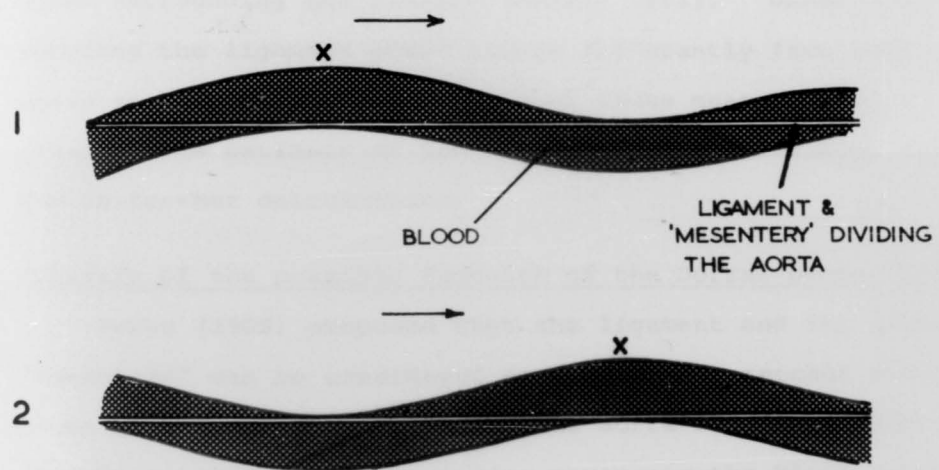

$$\frac{6 \times 10^6 \times 0.75 \times 0.15}{981 \times 3} = \text{Force /cm extension}$$

$$= 2.2 \text{ g/cm}$$

This rate of tension increase with length is plotted in figure 36 for comparison with the experimental values. It can be seen that at small extensions this ligament corresponds closely to Bergel's data but at the length in the living fish it is considerably stiffer than would be predicted.

The elasticity relations in natural fibres are complex (Alexander 1968) and can be modified by the nature of electrolytes surrounding the tissues (Bergel 1961). Under dynamic tensions the ligament would behave differently from under these sustained tensions. However these measurements do provide some estimate of the behaviour of the ligament for use in further calculations.

Analysis of the possible function of the Dorsal aorta ligament.

Burne (1909) proposed that the ligament and its attached "mesentery" can be considered as a curtain stretched along the lumen of the dorsal aorta. As the aorta bends with the Vertebral column during swimming movements the blood would be enclosed in successive compartments on either side of this curtain, corresponding to the series of waves executed by the fish. (figure 37). As these waves pass posteriorly along the body blood may be carried posteriorly along the aorta augmenting the circulation during exercise.

In the light of recent knowledge of swimming movements in rainbow trout and the above anatomical studies it is proposed to investigate theoretically the feasibility of Burne's hypothesis.



Figure 38. The idealised swimming waveform used in these studies for a 30cm long fish. The amplitude is 1 cm trunk region and 5cm at the tip of the tail. The wave shown as a dotted line is  $90^{\circ}$  behind the solid line.

veform used in  
long fish. The  
egion and 5cm  
The wave shown  
ehind the solid

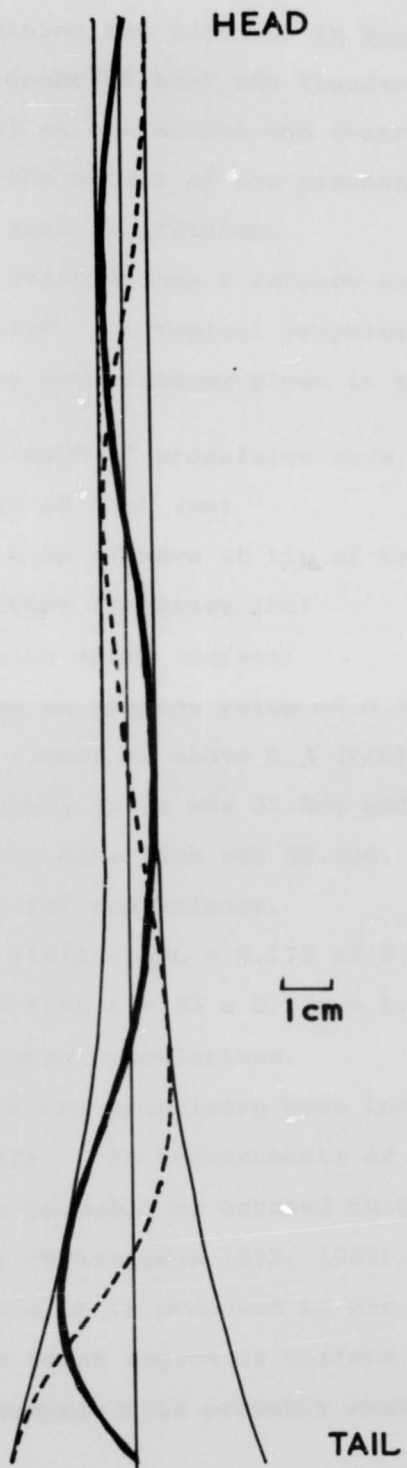

PL.

S/T

In closely examining the ligament in situ and with dye injections it seems doubtful that the ligament can act efficiently as a seal at the dorsal and ventral walls of the aorta. However at the outset of the present analysis it will be assumed that the seal is efficient.

As a basis for calculations a rainbow trout about 30cm long will be considered. A typical propulsive waveform for such a fish can be derived from figures given in the literature.

$\lambda$  = wavelength of propulsive wave (cm)

L = length of fish (cm)

A = amplitude of wave at tip of tail (cm)

f = tail beat frequency (hz)

V = swimming speed (cm/sec)

Webb (1971b) obtained an average value of  $0.76L$  for  $\lambda$  in trout of various sizes at speeds of above  $0.3 (V/L)$ . For a 30cm rainbow trout the actual value was 22.8cm and a theoretically derived figure for the same fish was 20.4cm.  $\lambda = 21.0\text{cm}$  will be assumed here for convenience.

Also from Webb (1971a)  $A/L = 0.175$  if f is greater than 5hz. Therefore for a 30cm fish  $A = 30 \times 0.175 = 5.25\text{cm}$ .  $A = 5.0\text{cm}$  will be assumed in these calculations.

The amplitude of the propulsive wave increases from head to tail (Bainbridge 1963). No measurements of this are available for trout but it can probably be assumed that trout is similar to Dace in this respect (Bainbridge 1958, 1963). Figure 38 shows the idealised waveform it is proposed to use in these studies. The amplitude in the trunk region is uniform (1cm). The error involved in this assumption is probably small: The dorsal

Figure 39. Plan of the dorsal aorta during one cycle of the ideal swimming wave. The scale is expanded 5 times in width relative to the longitudinal scale. The shading traces the history of one blood compartment assuming that Burne's hypothesis applies.



uring one  
g wave. The  
in width  
l scale.  
tory of one  
that Burne's

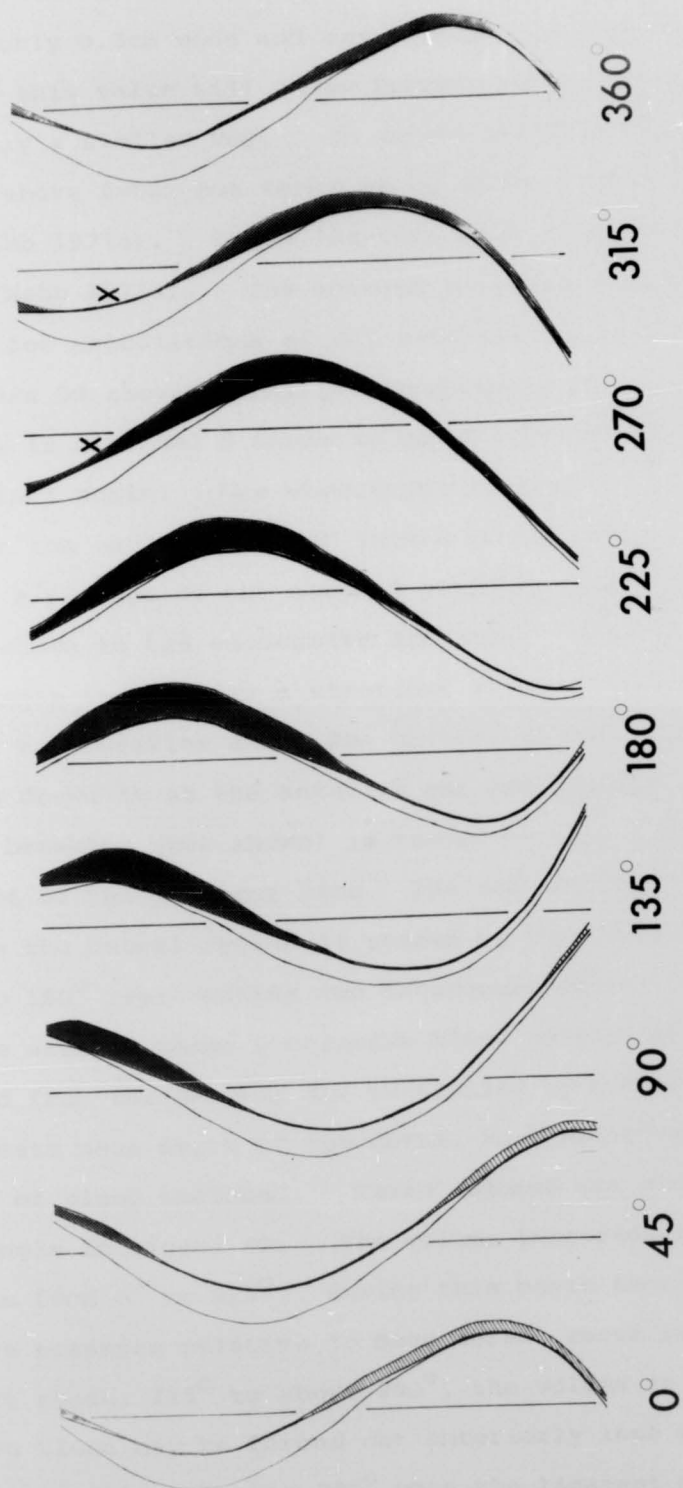

PL.

S  
H

aorta is only 0.3cm wide and any swimming wave amplitude in excess of this value will allow Burne's mechanism to work in essentially a similar way. In actual swimming fish  $\lambda$  is constant above  $f=5\text{hz}$  but tends to be smaller below this speed (Webb 1971a). Below  $1\text{hz}$  tail beat frequency  $\lambda$  is not uniform (Webb 1971a). The assumed waveform is probably adequate for calculations at all swimming speeds above  $f=1\text{hz}$ .

Figure 39 shows a plan of the dorsal aorta; for clarity the scale is expanded 5 times in width relative to the longitudinal scale. One wavelength is shown which corresponds to almost the entire "active" length of the ligament. One cycle of a passage of the assumed swimming wave down the body is shown in the successive diagrams. The position of the ligament is drawn as a stretched elastic line from the anterior to posterior end. The history of one compartment of blood is drawn in at the anterior end and ejected through the lateral branches (not shown) is traced by the shaded area to the right of the ligament line. The completion of the ejection phase in the caudal region is traced by the cross hatched area in  $0^\circ$  to  $180^\circ$  representing the subsequent cycle.

The area of these successive blood compartments was measured from the drawing and multiplied by 0.05cm, the approximate mean depth of the aorta, to give an estimate of the volumes of blood enclosed. These volumes are plotted against phase angle in figure 40. The volume increases as blood is drawn in from  $0^\circ$  to  $225^\circ$ ; during this phase there would be a negative pressure relative to mean dorsal aorta pressure. In the next phase,  $225^\circ$  to about  $290^\circ$ , the volume is decreasing but some blood may be forced out anteriorly into the branchial arteries. Only at about  $290^\circ$  when the ligament makes a seal

Figure 40. Estimated volumes of one blood compartment enclosed by the dorsal aorta ligament during one cycle of the Burne type pumping action.

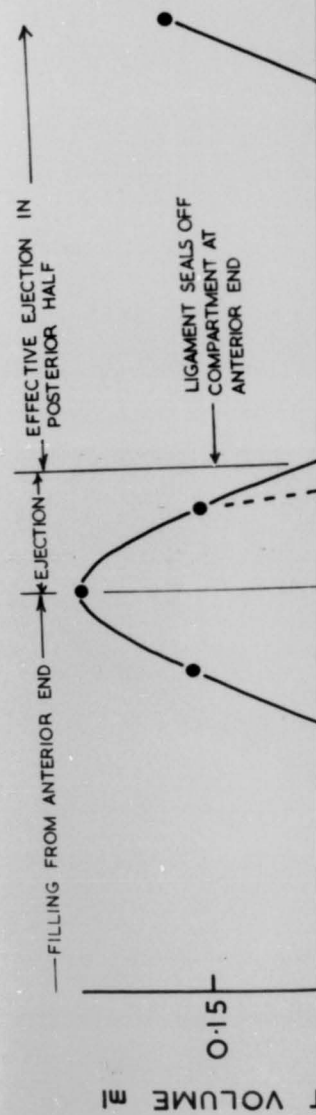

lood compartment  
ta Ligament during  
e pumping action.

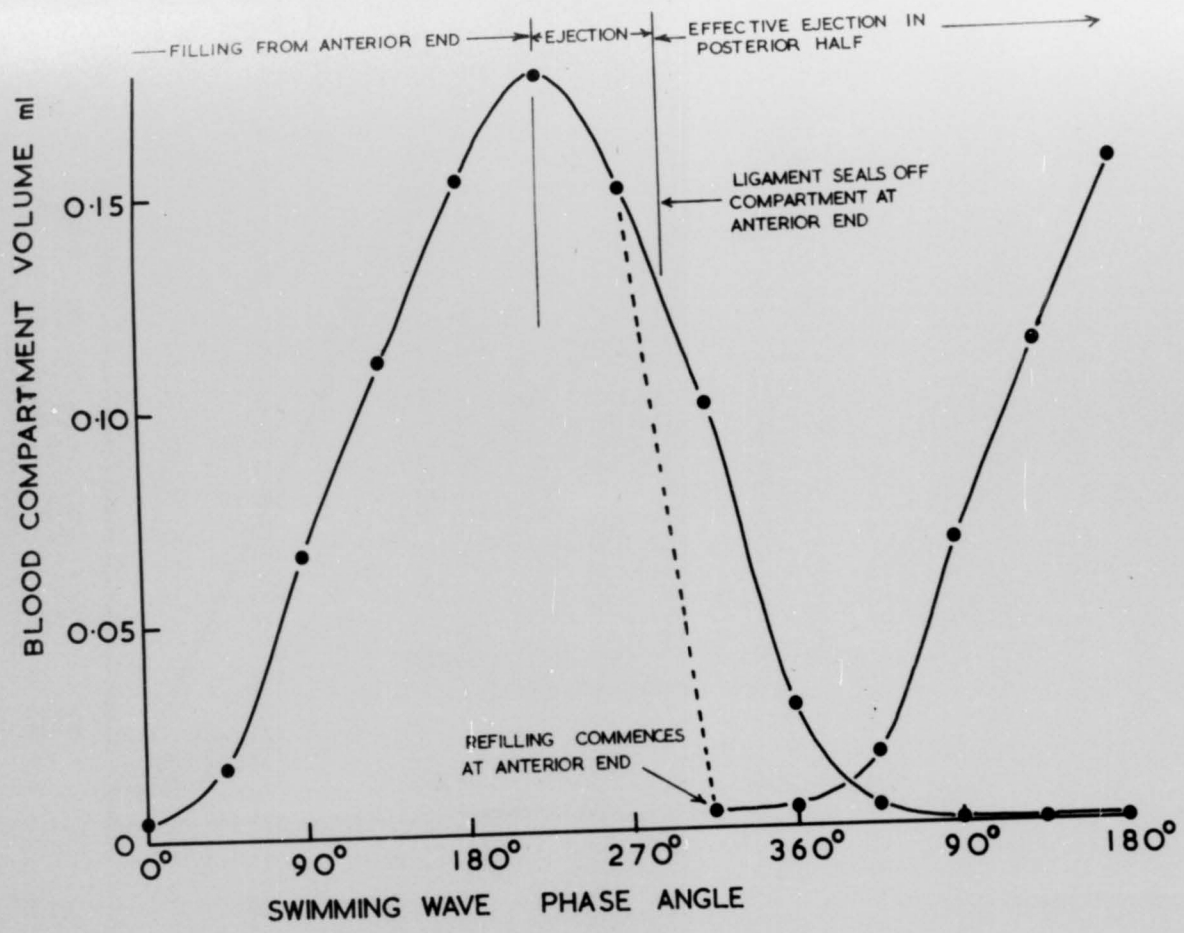

PL

3/1



of the dorsal  
the caudal lymph  
at frequencies  
output.

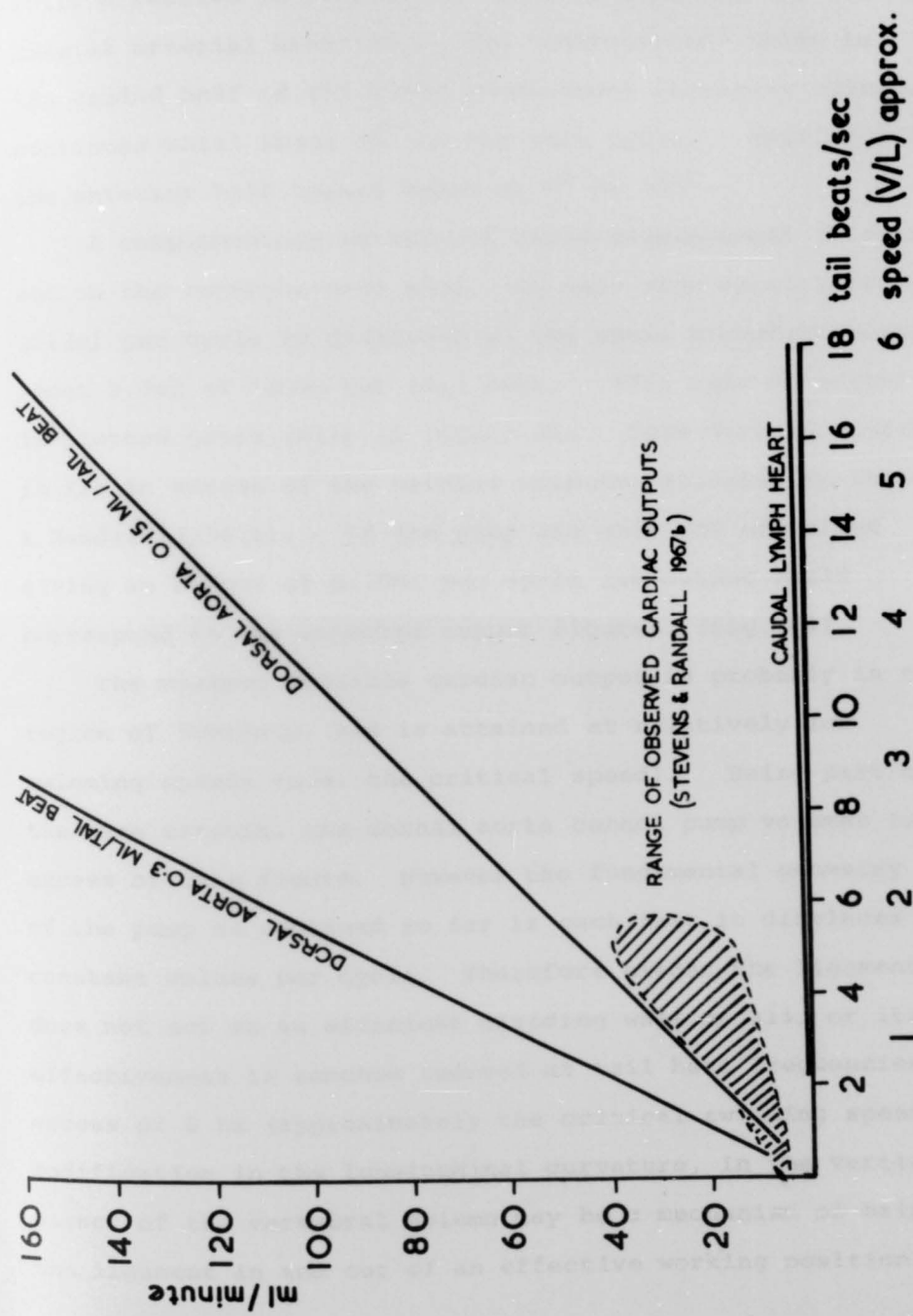

PL.

5/1

Figure 41. Theoretical volume outputs of the dorsal aorta pump mechanism and the caudal lymph heart at different tail beat frequencies compared with the cardiac output.

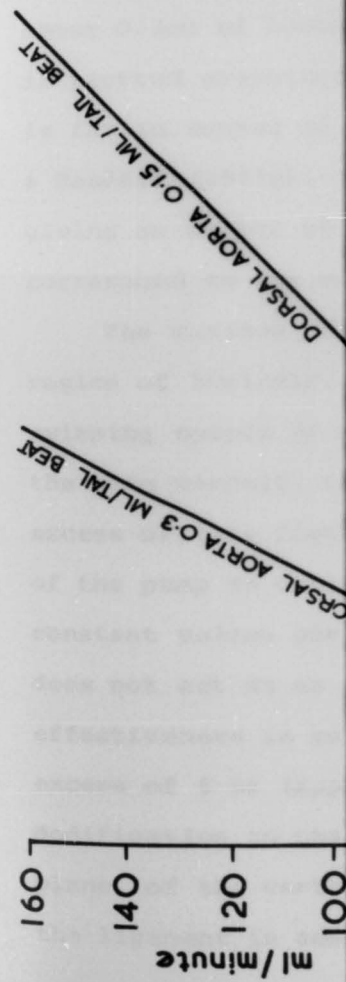

of the dorsal  
the caudal lymph  
at frequencies  
output.

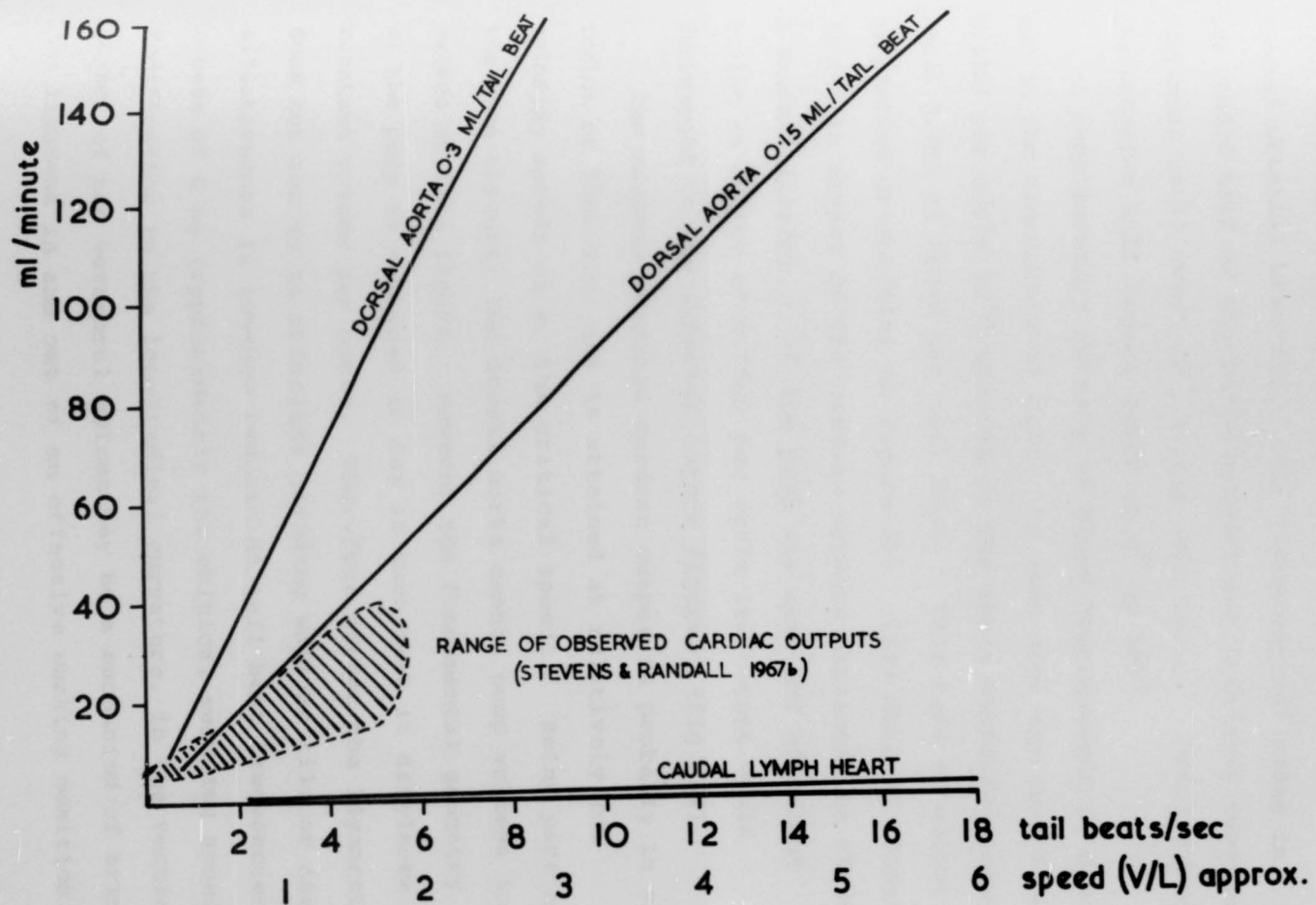

PL

1/15

at point X on the diagram (fig. 39) could the pump become fully effective in propelling blood posteriorly and into the lateral arterial branches. The "compression" phase in the caudad half of the blood compartment initially considered continues until about  $90^\circ$  in the next cycle. Refilling of the anterior half begins again at  $0^\circ$  or  $360^\circ$ .

A complementary pattern of blood displacement is carried out on the contralateral side. On each side approximately 0.15ml per cycle is displaced so the whole mechanism pumps about 0.3ml of blood per tail beat. This rate of output is plotted graphically in figure 41. This derived output is far in excess of the cardiac outputs estimated by Stevens & Randall (1967b). If the pump was only 50% efficient giving an output of 0.15ml per cycle its output would correspond to the expected output figures. (fig. 41).

The maximum possible cardiac output is probably in the region of 50ml/min. and is attained at relatively low swimming speeds (i.e. the critical speed). Being part of the same circuit, the dorsal aorta cannot pump volumes in excess of this figure. However the fundamental geometry of the pump as outlined so far is such that it displaces a constant volume per cycle. Therefore either the ligament does not act as an efficient dividing wall at all, or its effectiveness is somehow reduced at tail beat frequencies in excess of 6 hz (approximately the critical swimming speed). Modification in the longitudinal curvature, in the vertical plane, of the vertebral column may be a mechanism of bringing the ligament in and out of an effective working position.

Figure 42. (a) one half wavelength of the swimming wave in the aorta showing breakdown of the pump mechanism (scale expanded in width).

(b) The ligament and its attached mesentery as considered for calculations as a segment of a cylinder.

(b)

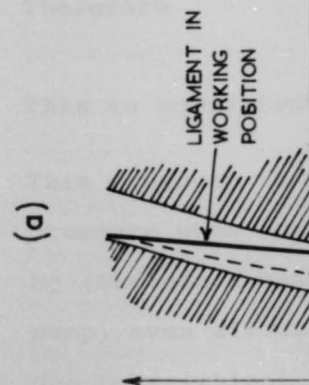

the swimming  
breakdown of  
expanded in

attached  
or calculations

(b)

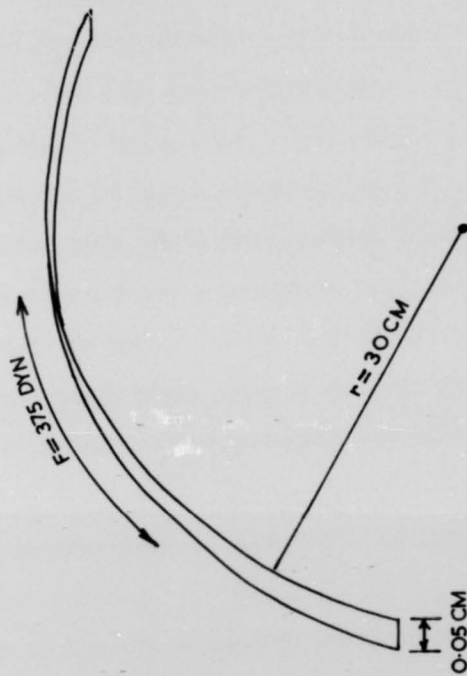

(a)

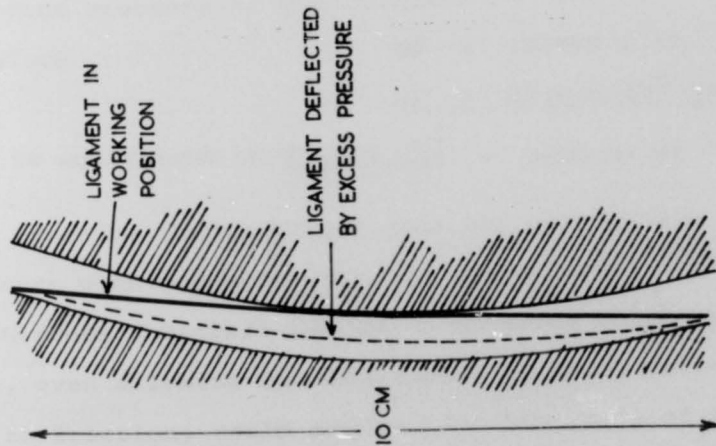

PL.

5/1

At high swimming speeds the pressure difference across the ligament may be sufficient to deflect it so that it becomes ineffective as a pump (fig. 42a). This would occur at a particular pressure produced at a particular speed which would be determined by the elastic properties of the ligament. This breakdown pressure can be calculated. Taking a segment of the ligament 10cm long ( $\lambda/2$  approx.) the pressure, BP required to stretch it by a minimal amount (say 0.1cm) will be taken as the breakdown pressure. From figure 36 the tension increase required to stretch a 10cm length of ligament in the fish by 0.1cm is 8g. The "curtain" dividing the dorsal aorta in one half wave length can be considered as part of the wall of a cylinder of approximately 30cm radius (r) (fig. 42b).

The circumferential tension in the wall of such a cylinder 1cm long = T.

$$T = 8 \times 981 \times 1/0.05 = 156960 \text{ dynes/cm (Alexander 1968)}$$

Therefore pressure in the cylinder =  $T r$

$$\text{Therefore } BP = 156960 \times 30$$

$$BP = 47.0 \times 10^5 \text{ dynes/cm}$$

$$\text{This is equivalent to } \frac{47.0 \times 10^5}{1.33 \times 10^3} = 3500 \text{ mm Hg}$$

This pressure is far larger than any conceivable physiological pressure when compared with the dorsal aorta pressure of 30 mm Hg (Stevens & Randall 1967b). It seems unlikely that the pump, even allowing for additional ligament deflecting forces due to friction, could suffer from breakdown of this type at high speeds.

In conclusion on theoretical grounds it appears unlikely that the pump could be fully efficient in the sense that Burne (1909) proposed over the full range of swimming speeds. If it is effective at low speeds this effectiveness must be reduced at high speeds in order to avoid massive pressure oscillations in the dorsal aorta.

Experiments with the Fish Bending Machine.

On the trout cadaver dorsal aorta preparation.

About 20 experiments were carried out on the fish bending machine using the dorsal aorta preparation. No convincing evidence of pumping activity could be found. No increase in mean output pressure from the caudal artery could be detected. Pressure oscillations coinciding with the tail beat frequency were measured up to  $\pm 20$ mm Hg about mean. These large oscillations were largely caused by movement of the cannula. With careful damping of the cannula smaller oscillations were detected but these could not be ascribed with any certainty to the dorsal aorta mechanism.

Some leakage of saline took place through the lateral segmental arteries but this was not large enough to exclude the measurement of quite high mean pressures in the aorta. Using the volume of saline in the caudal cannula held vertically the mean aorta pressure could be measured quite sensitively. Often a fall in this pressure was detected during "swimming movements". This was probably caused by increased flow through the segmental arteries. However in view of the pressure drop this increased flow was probably caused by the movement freeing more flow channels rather than a pumping action when a pressure rise would be detected.



Figure 43. Dorsal aorta model (tube and elastic) function curves derived from experiments with the fish bending machine. Lower graph - maximum output pressure at different "tail beat" frequencies. Upper graph - volume output at different frequencies with three different constant pressure drops across the pump mechanism (measured in mm of water).

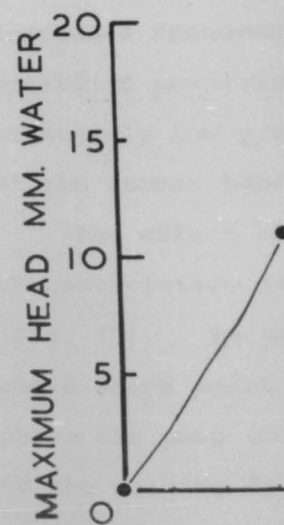
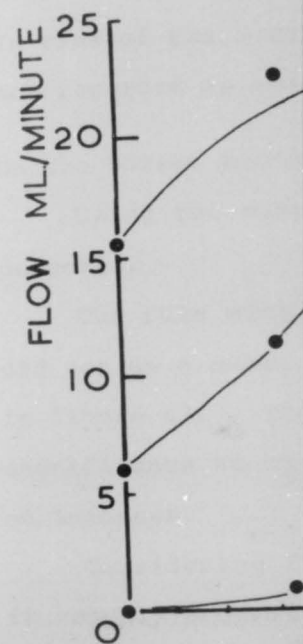

and elastic)  
from experiments  
nine. Lower  
pressure at  
frequencies.  
at at different  
different  
cross the pump  
(of water).

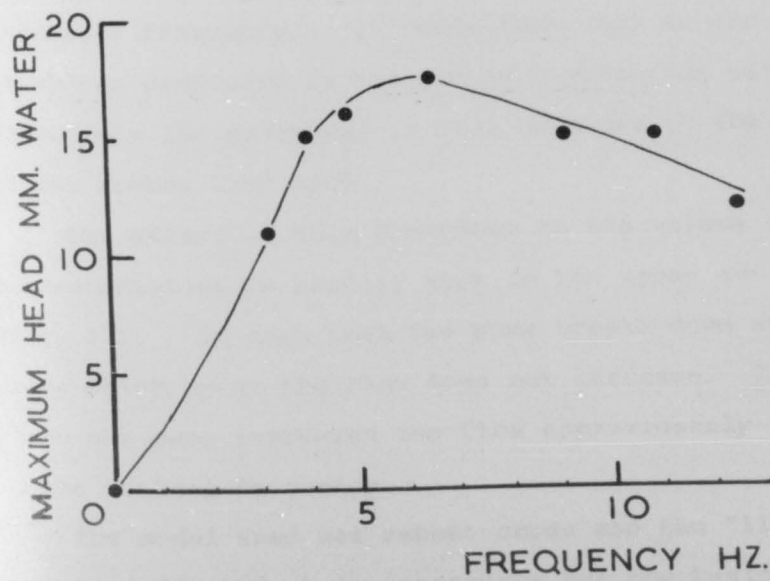
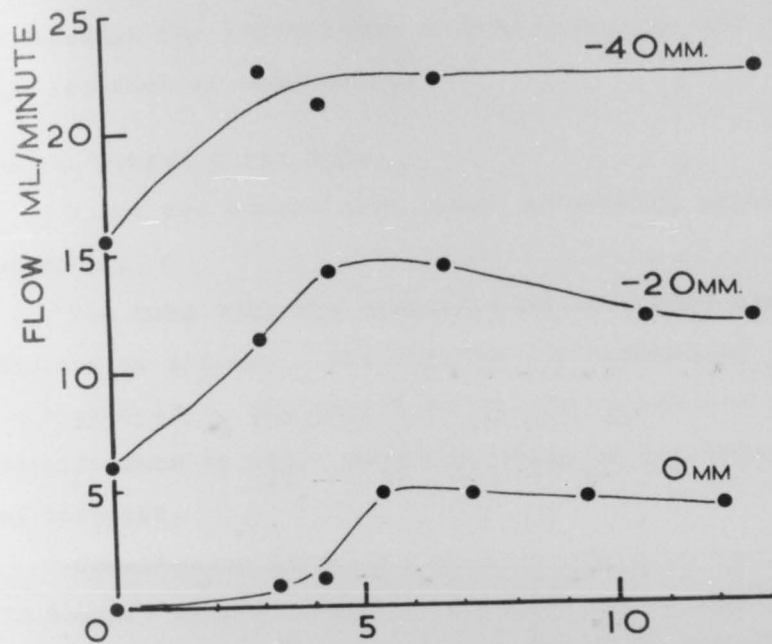

PL.

S/T

No pumping activity could be detected and the technique was not appropriate for the study of the nature of the oscillatory pressure pulse produced by the body movements. In view of the limitations of the technique the results are not regarded as conclusive.

On the Dorsal Aorta Model.

Using the simple tube model no pumping activity was detected.

The tube with the elastic band stretched along the lumen did act as a pump. The results are summarised graphically in figure 43. The magnitude of the values has no physiological significance at all; only the shape of the relationships is of interest.

Considering first the maximum pressure head produced, it is roughly proportional to frequency up to 5hz when break down takes place and the maximum pressure produced falls with increased frequency. It seems that this is the type of breakdown predicted in the theory section but which occurs at relatively low pressures in this case due to the extensibility of the rubber band used.

The effect of this breakdown on the volume flow characteristics is readily seen in the upper set of curves (fig. 43). In each case the pump breaks down at about 5hz above which point the flow does not increase. In its functional phase the pump increases the flow approximately in proportion to the working frequency.

The model used was rather crude and the "ligament" was readily deflected at low pressures but the basic principles of

the Burne type of mechanism were demonstrated. The geometry of the model was such that even under optimum conditions some leakage took place past the ligament.

#### Heart Structure

The main aim of this investigation of the heart anatomy was to elucidate the geometry and spatial relationships of the various mechanical elements which may be of importance in the interpretation of the hearts functional characteristics.

The gross morphology of the heart is probably best appreciated in figures 44 and 45 showing casts of the heart and the immediate major blood vessels. The ducti cuvierii and hepatic veins empty into the sinus venosus which is virtually incorporated into the posterior wall of the pericardium. The other chambers of the heart; the atrium lying dorsal to the ventricle and bulbus are freely suspended in the pericardial cavity; the bulbus being anchored anteriorly by the ventral aorta.

#### SINUS VENOSUS.

The walls of the sinus are thin and consist of connective tissue containing large amounts of collagen as shown by its red staining with Van Geison's stain. (fig.46b). There was no evidence of muscle fibres in the sinus wall. The sinus venosus is in fact little more than the confluence of the major veins entering the heart. The volume of the cast was estimated at approximately 0.08ml.

#### ATRIUM.

The castings of the atrium show the internal surface to be rather irregular. The very outer wall of the atrium consists of connective tissue including collagen and some

Figure 44. Silicone rubber cast of the heart chambers,  
lateral view. A - atrium, ABA - afferent  
branchial artery, BA - bulbus arteriosus,  
DC - ductus cuvieri, HV - hepatic vein,  
LPCV - left posterior cardinal vein,  
RPCV - right posterior cardinal vein, SV -  
sinus venosus, VA - ventral aorta.

Figure 45. Siliccon rubber cast of the heart chambers,  
dorsal view. Key as for fig. 44.



heart chambers,  
BA - afferent  
arteriosus,  
hepatic vein,  
portal vein,  
portal vein, SV -  
aorta.



heart chambers,  
. 44.



PL.

S/T

Figure 46. Section of part of the wall of the sinus venosus. (Van Geison's stain). The dense staining indicates the presence of large amounts of collagen.

Figure 47. Section of part of the wall of the atrium. (Haematoxylin and eosin). C - connective tissue in the sub-epicardial region. M - muscle bundles, E - erythrocytes.

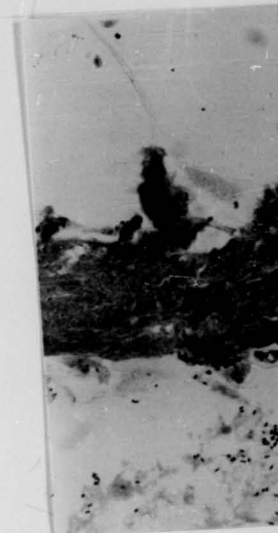

of the sinus  
) . The dense  
nce of large

of the atrium.  
C - connective  
region. M -  
ytes.

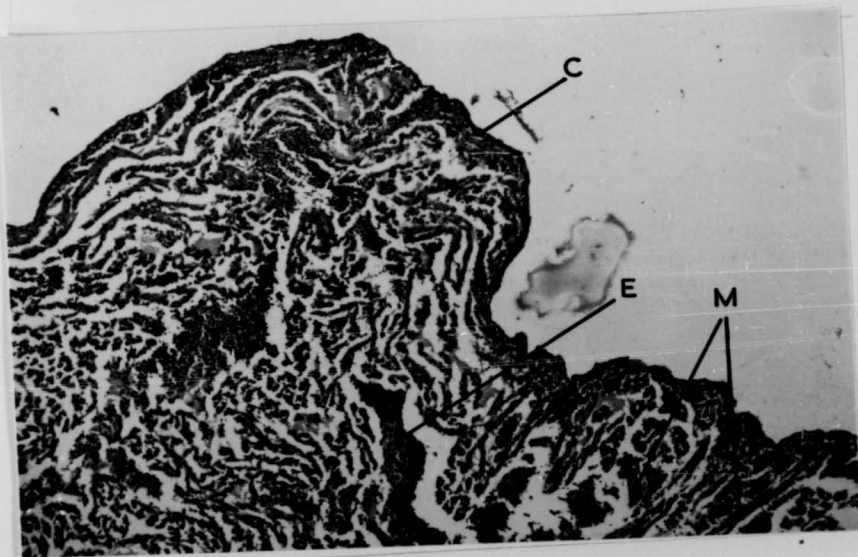
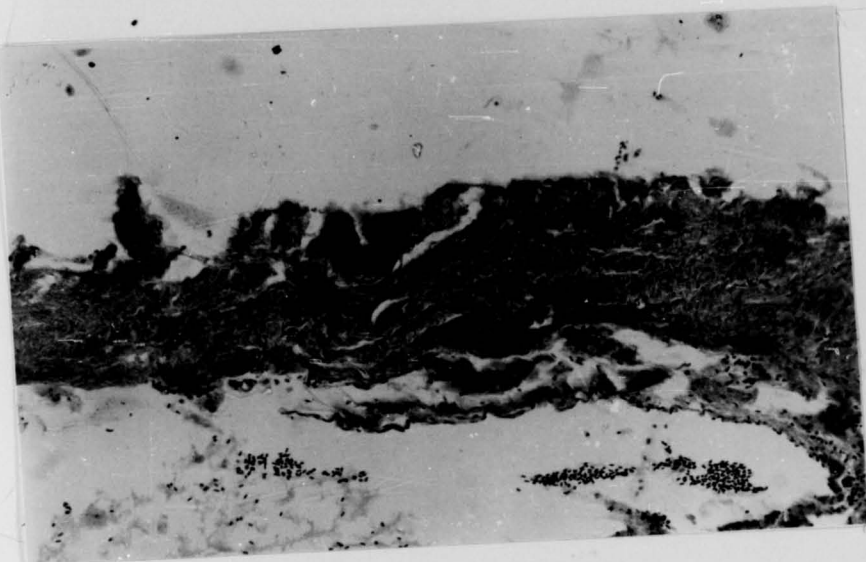

PL.

S/T



Figure 48. Longitudinal vertical section through the heart (Haematoxylin and eosin). A - atrium, BA - bulbus arteriosus, SC - stratum compactum of the ventricular myocardium, SM - spongy ventricular myocardium, SV - sinus venosus.

Figure 49. Section of the wall of the ventricle (Orcein elastica) showing elastic fibres in the outer part of the wall. EF - elastic fibres.

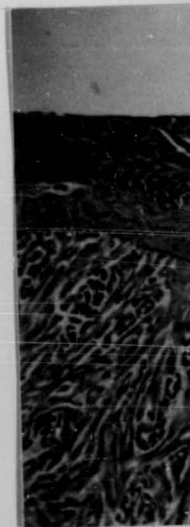
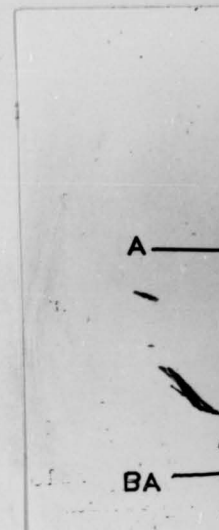

on through the  
(n). A -  
us, SC -  
us, SC  
tricular  
tricular  
sus.

ventricle  
lastic fibres  
ll. EF -

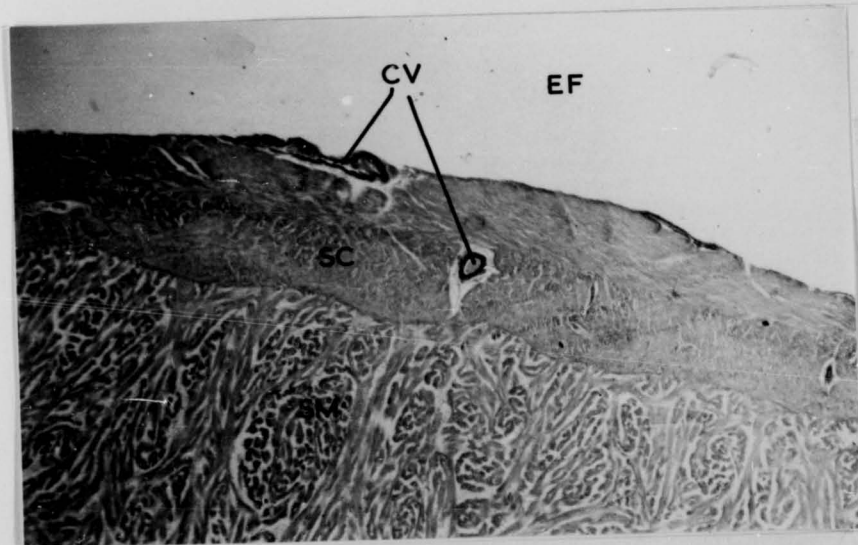
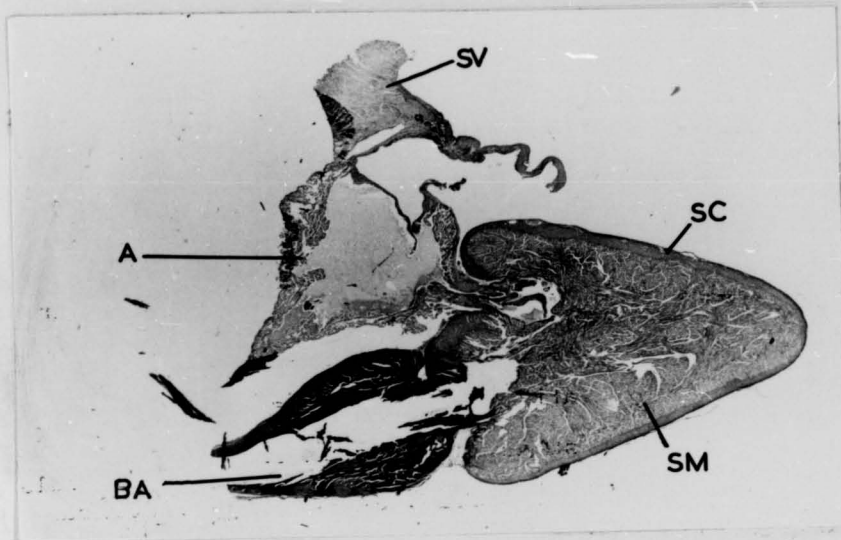

PL.

S/T

Figure 50. Section of wall of ventricle (Van Geison stain) showing collagen fibres in the outer part of the wall and coronary vessels. CF - collagen fibres, CV - coronary vessels.

Figure 51. Longitudinal section of a ventricle expanded to a dilated diastole with 'vaseline' (haematoxylin and eosin).

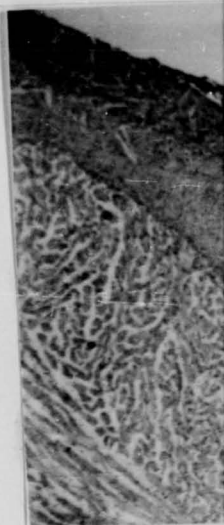

SM

e (Van  
gen  
the wall  
- collagen  
ls.

entricle  
ble with  
e eosin).

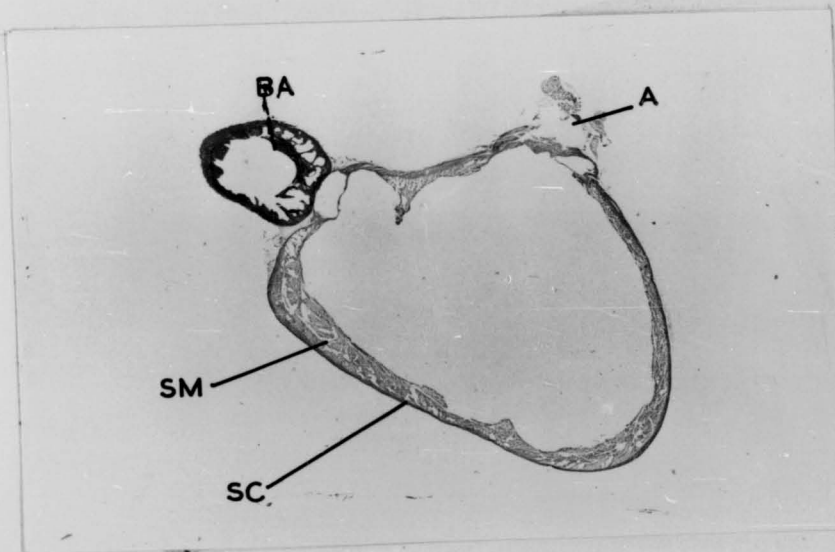
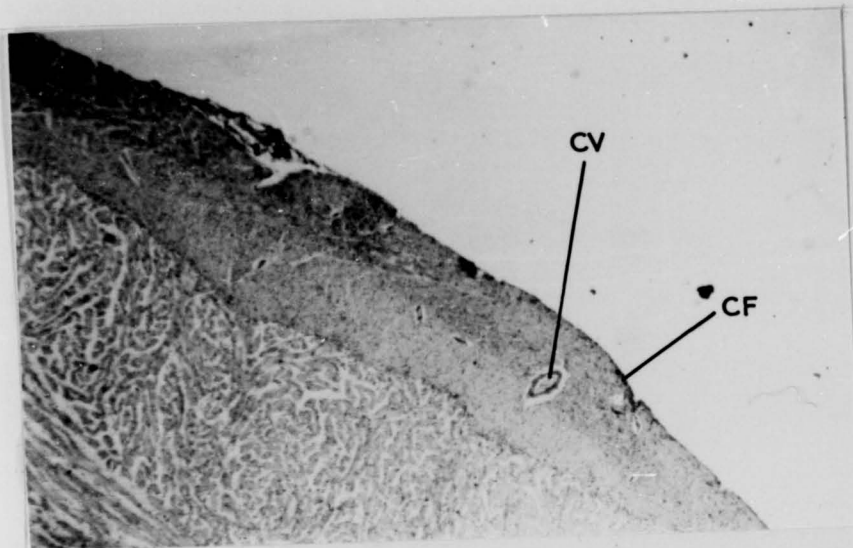

PL.

S/T

Figure 52. Silico rubber cast of the bulbus arteriosus. VA - ventral aorta, LR - casts of longitudinal ridges. R - basal region with large numbers of radial fibres giving a spongy appearance.

Figure 53. Transverse section of bulbus arteriosus towards the anterior half showing elastic fibres. (Orcein elastica). CF - circumferential fibres, LE - longitudinal elements, RF - radial fibres.

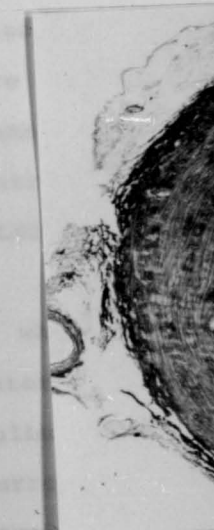

bulbus  
orta,  
ridges.  
numbers  
pongy

s  
rior half  
cein  
ential  
lements,

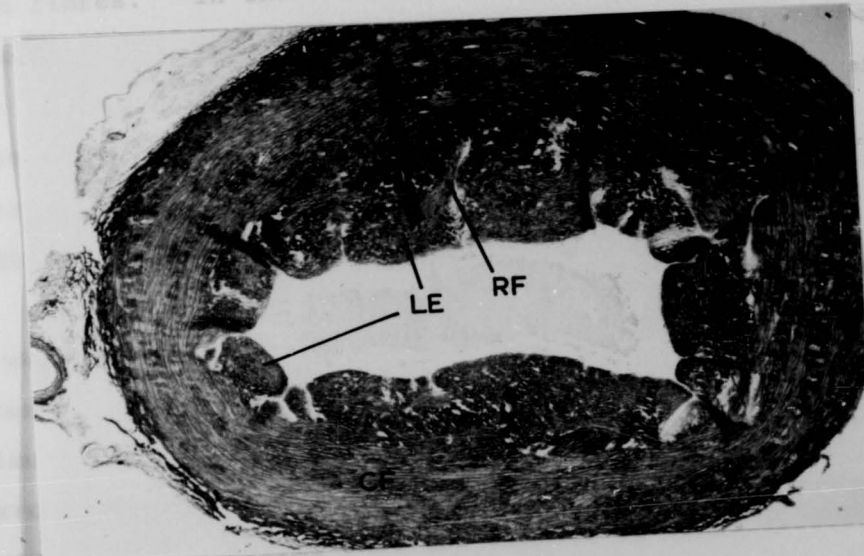
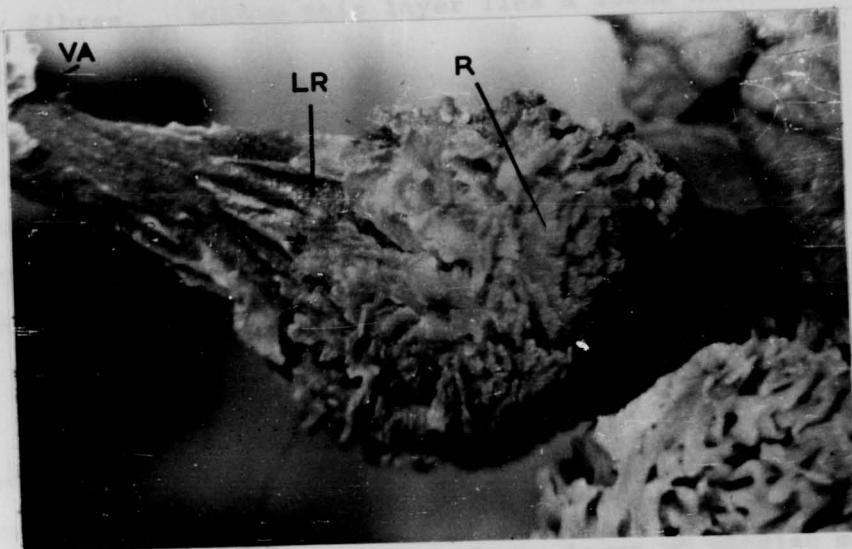

PL.

S/T

elastic fibres. Within this layer lies a loose network of cardiac muscle fibres many of which traverse the lumen of the atrium (fig. 47). A pair of simple flap valves guard the sino-atrial opening. No coronary blood vessels are present in the atrial wall.

#### VENTRICLE.

The ventricle is pyramid shaped and in ordinary sections there is little evidence of a lumen (fig. 48). In the very outer layers of the ventricular wall there is some connective tissue; collagen and elastic fibres (figs. 49 and 50). The coronary blood vessels also run in this outer layer. Inside the connective tissue there is a dense layer of cardiac muscle known as the stratum compactum. The rest of the ventricular myocardium is the spongy layer which extends to almost completely occlude the lumen when the heart is contracted (fig. 48). The casts in particular show that the fibres of this layer extend across the lumen and the blood runs between all these fibres. In the sections of the ventricle expanded with "Vaseline" it can be seen that the spongy layer fibres become more orientated and an open lumen appears in the centre of the chamber. (fig. 51). Valves are present at the atrio-ventricular and ventriculo-bulbar interconnections.

#### BULBUS ARTERIOSUS.

The bulbus is an onion shaped chamber the anterior end of which merges into the ventral aorta. The coronary artery entering the heart runs along the ventral surface of the bulbus. Simple dissection reveals a series of longitudinal furrows on the inner wall of the bulbus and the silicone rubber cast (fig 52) confirms that the chamber is trabeculated.

Figure 54. Transverse section of the bulbus arteriosus (Haematoxylin and eosin). The main atructural elements are shown as in fig. 53 and the smooth muscles are shown. AD - adventitia.

Figure 55. Transverse section of the bulbus arteriosus expanded with agar. (Haematoxylin and eosin).





albus  
(e eosin).  
s are  
smooth  
ventitia.



albus  
ar.

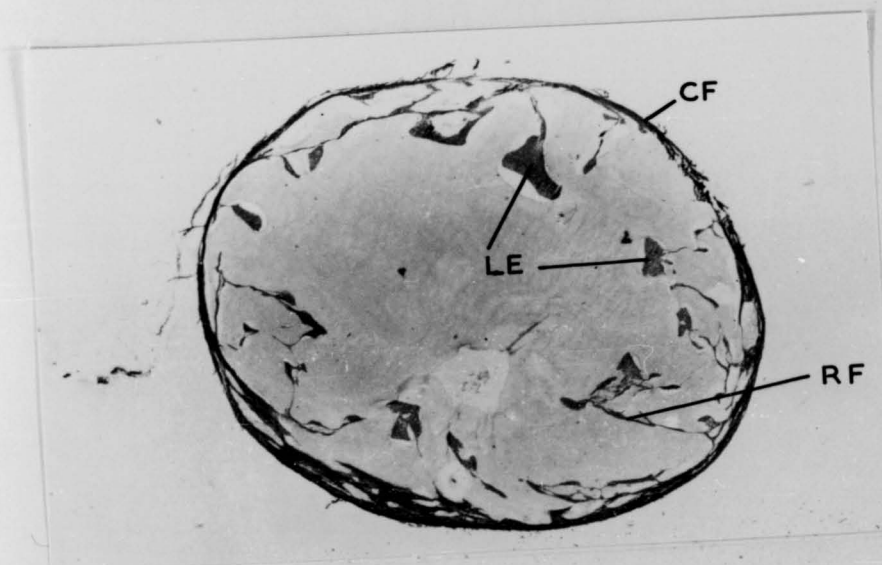

PL.

S/T

Figure 56. Isometric projection drawings of the bulbus arteriosus as reconstructed in the expanded and contracted states.

1 - anterior wall of pericardium,  
2 - wall of ventricle, 3 - ventriculo-bulbus valve, 4 - adventitia, 5 - main longitudinal element, 6 - radial element, 7 - compact layer of media with primarily circumferential fibres.

## Bulbus Arteriosus

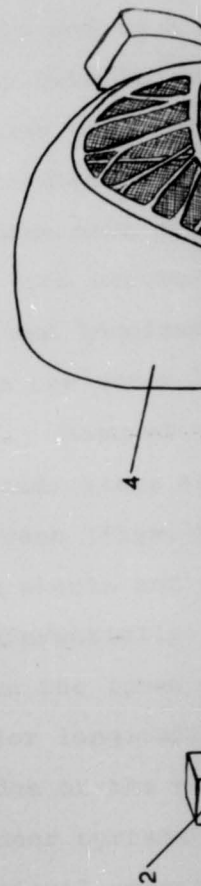

gs of the  
structed in  
states.  
rdium,  
ventriculo-  
a, 5 - main  
radial  
of media with  
fibres.

### Bulbus Arteriosus

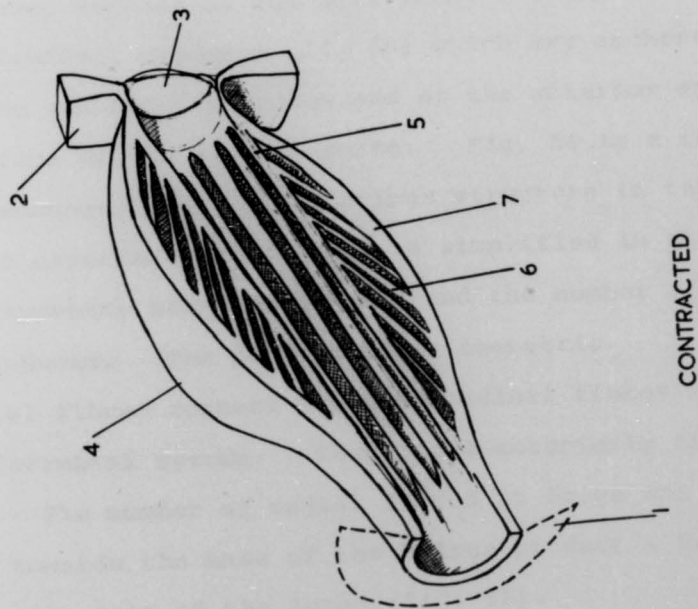
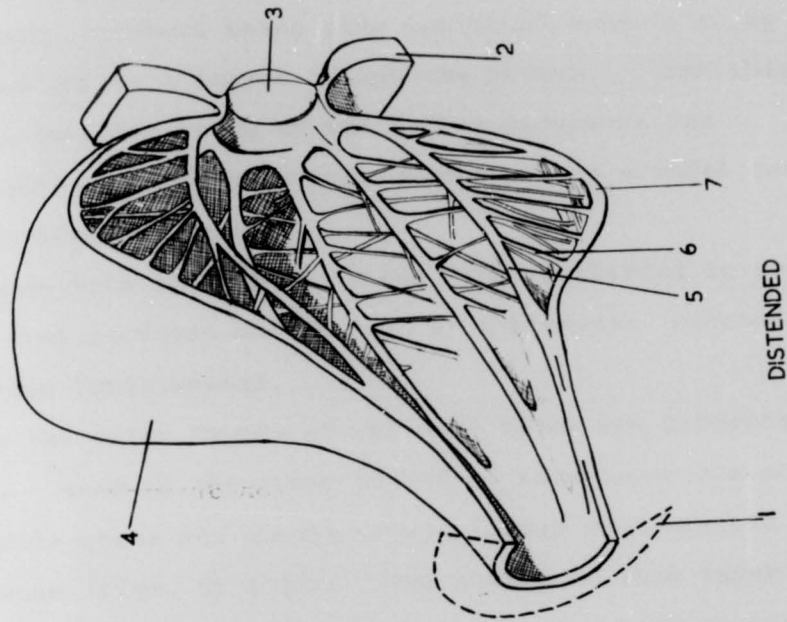

Trabeculation appears to be a significant feature of the trout heart chambers being also exhibited especially by the ventricle and to a lesser extent the atrium. For this reason a detailed study of the bulbus structure was undertaken which could to some extent act as a model for the other cardiac chambers.

Three main systems of fibres were identified in the bulbus from sections and studies of the casts: circumferential, radial and longitudinal.

In the outer layers of the wall there are circumferential fibres. Many of the outer fibres of this layer are collagen and inside there are smooth muscle fibres with elastic fibres in between (figs. 53 & 54). The fibres in this layer tend to run in whorls and spirals but the main axes tend to lie circumferentially.

On the inner surface of the wall there are approximately 10 major longitudinal elements (fig 55) which are anchored at the edge of the ventricular valves and at the anterior end on the inner surface of the ventral aorta. Fig. 56 is a three dimensional reconstruction of the bulbus structure in the contracted and expanded states. It is simplified in that exact radial symmetry has been assumed and the number of radial elements is reduced. The projection is isometric.

The radial fibres connect the longitudinal fibres to the outer circumferential system. They slope anteriorly towards the outside. The number of radial fibres is large and particularly towards the base of the bulbus produce a fragmental appearance to the cast of the lumen (fig. 52).

Figure 57. The relationship between pressure and volume in the bulbus arteriosus of a 20cm rainbow trout. Results of two consecutive expansion and contraction cycles are shown.

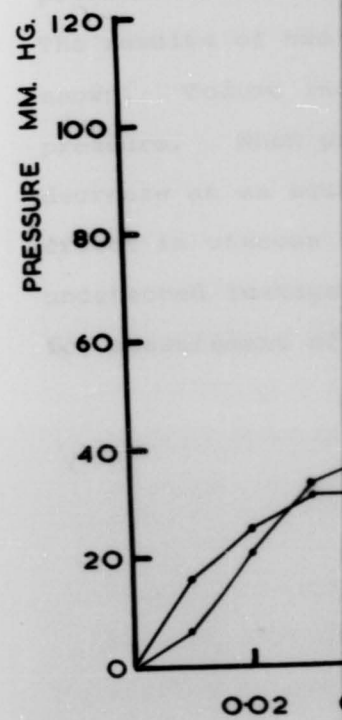

Pressure and  
Tonus of a  
muscle of two  
contraction

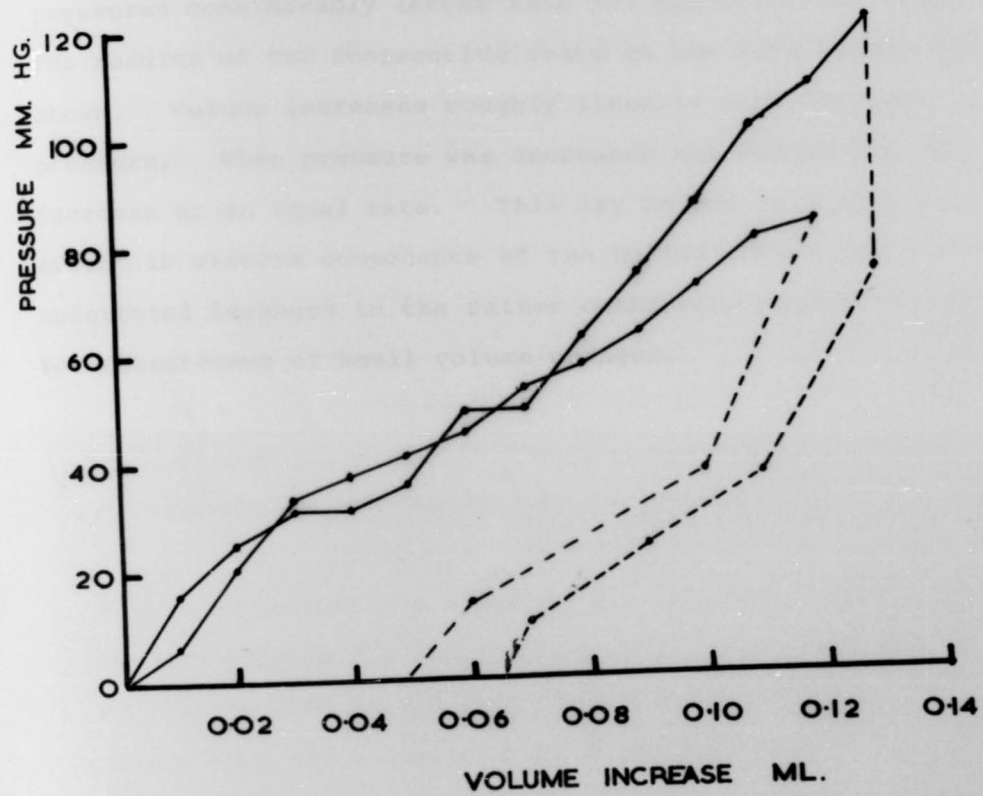

PL.

S/T

## BULBUS PRESSURE - VOLUME RELATIONS.

Some simple measurements of the pressure-volume relationship were made in the bulbus of a 20cm fish. The results are shown graphically in figure 57. Measurements were taken for increasing and decreasing pressure over a range of pressures considerably larger than the physiological range. The results of two consecutive tests on the same bulbus are shown. Volume increases roughly linearly with increase in pressure. When pressure was decreased the volume did not decrease at an equal rate. This may be due to a hysteresis effect in viscous components of the bulbus structure or due to undetected leakages in the rather cumbersome apparatus used for measurement of small volume changes.

## DISCUSSION

Heart Rate in Relation to Metabolism

One of the main themes of this study has been the regulation of heart rate in relation to changes in respiratory transport requirements imposed upon the circulatory system. The heart rate has been measured under various conditions in which something is also known of the changes in metabolic rate. From this basis estimates can be made of the contribution of heart rate changes, to changes in oxygen transport to the tissues.

## THE EFFECT OF SWIMMING ACTIVITY.

Brett (1964) carried out extensive studies on oxygen consumption in relation to swimming activity in Onchorhynchus nerka and showed that the logarithm of oxygen consumption is proportional to swimming speed:

$$\text{LogO}_2 = a + b (V/L) \quad (1)$$

It was shown that the value of the constant b varied between 0.34 at 5°C and 0.17 at 24°C. Tytler (1969) in similar studies on Melanogrammus aeglefinus, a marine fish, showed that the value of b could be expected to be close to 0.3 in a wide variety of fish at their respective optimum temperatures. The data of Rao (1968) and Kutty (1968) for rainbow trout yield values of b of the order of 0.2. However Webb (1971) gives a value of 0.47 at 15°C for hatchery reared rainbow trout. The critical speeds in Webb's work are low and it is possible that this is connected with the high b value. Morgan (1974) also found low critical speeds in hatchery reared brown trout but the b value was 0.25. Webb (1971) suggested that the low



swimming speeds in his work were due to lack of exercise and the effect of hatchery rearing techniques. Dickson and Kramer (1971) confirm this view in their findings that maximum swimming speeds in wild rainbow trout were approximately 25% higher than in hatchery fish. The critical speeds found in the present study; 1.5(V/L) at 6.5°C and 2.0(V/L) at 15°C, correspond closely to the values obtained by Webb (1971) and Morgan (1974) and are probably typical of many hatchery reared fish.

For the purposes of discussion a convenient value of 0.3 will be assumed as the value of  $b$  for rainbow trout at all temperatures. If the amount of oxygen transported per heart beat (the  $O_2$  pulse) remains constant then in the swimming trials the heart rate should increase logarithmically with swimming speed with a  $b$  value of 0.3 up to the critical speed where no further increase in oxygen transport to the tissues can take place.

For the intact group of fish at 6.5°C the mean basal heart rate was 32.54. Therefore if the  $O_2$  pulse remains constant:-

$$\text{Log HR}_t = 1.5124 + 0.3(V/L) \text{ at } 6.5^\circ\text{C} \quad (2)$$

Where  $\text{HR}_t$  = the theoretical heart rate if the  $O_2$  pulse remains constant at the value at rest. The critical speed (the point where the 50% recovery time curve rises steeply) was 1.5(V/L).

In the intact group of fish at 15°C the mean basal heart rate was 45.52. Therefore if the  $O_2$  pulse remains constant:-

$$\text{LogHR}_t = 1.6582 + 0.3(V/L) \text{ at } 15^\circ\text{C} \quad (3)$$

and the critical speed at this temperature was 2.0(V/L).

Figure 58. Changes in heart rate with specific speed at 6.5°C and 15°C.  $HR_t$  is the theoretical heart rate if the  $O_2$  pulse remains constant at its value at  $O(V/L)$  and is compared with the actual observed heart rates (HR).

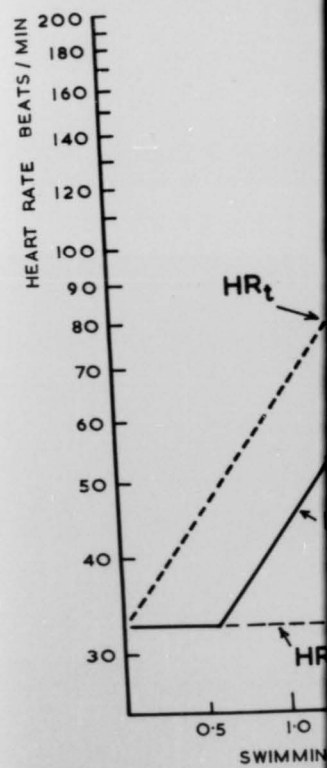

specific  
 $HR_t$  is the  
the  $O_2$  pulse  
value at  
the actual

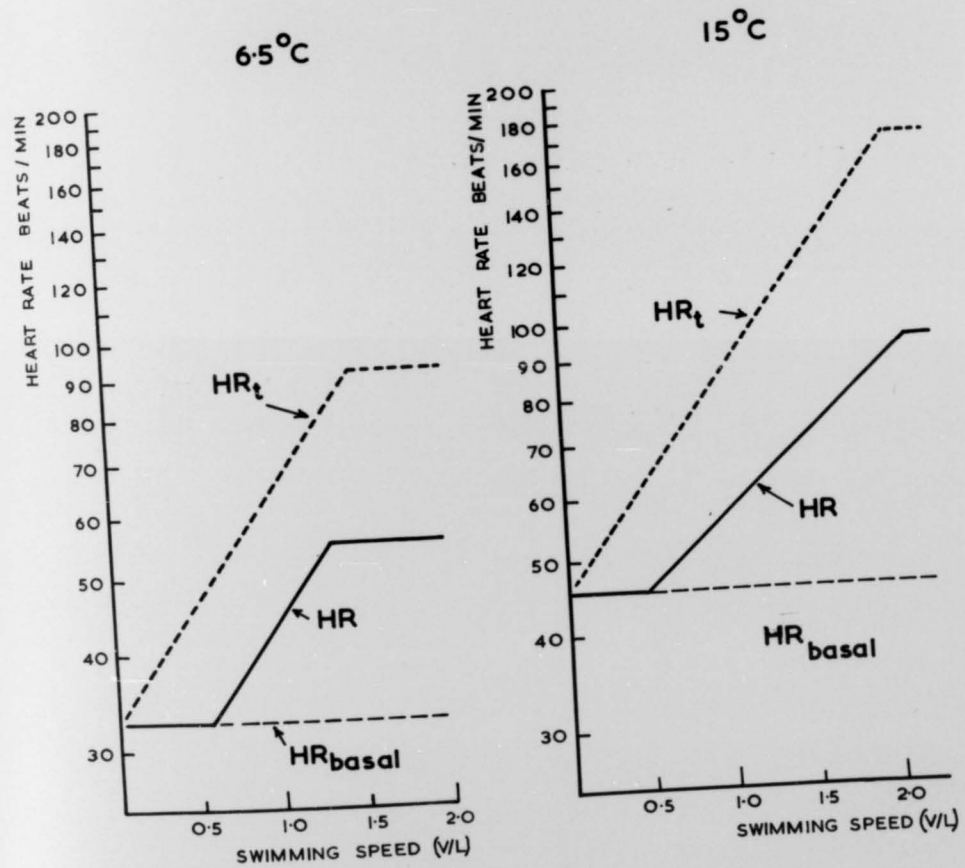
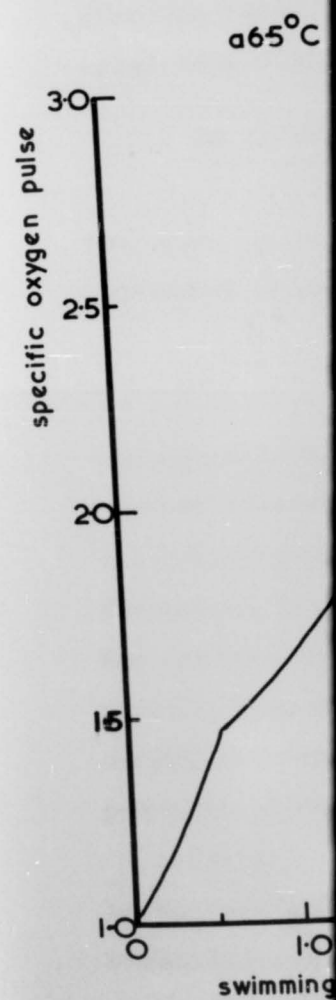
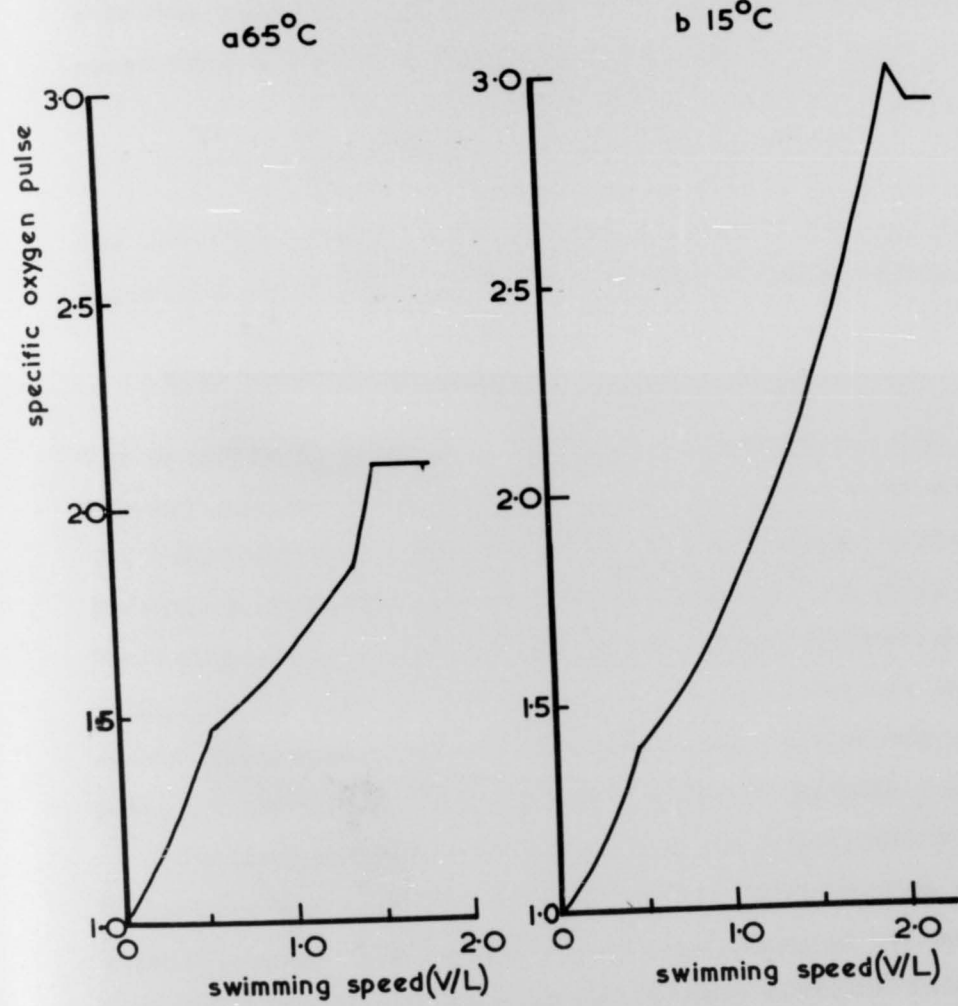

Figure 59. The specific  $O_2$  pulse in relation to swimming speed at  $6.5^\circ C$  and  $15^\circ C$ . The specific  $O_2$  pulse is a measure of the change in amount of oxygen carried to the tissues per heart beat.



relation to  
and 15°C.  
a measure of  
oxygen  
heart beat.



PL.

S/T

These two constant  $O_2$  pulse heart rate relationships are plotted in figure 58 and are compared with the actual changes in heart rate obtained in the experiments. The difference between the two lines represents a deficit in oxygen transport measured in terms of heart beats. This difference is a measure of how much the oxygen pulse changes over the range of swimming speeds. For any given swimming speed this difference can be expressed as:-

$$\frac{HR_t - HR + HR_{\text{basal}}}{HR_{\text{basal}}} = \text{Specific } O_2 \text{ pulse.} \quad (4)$$

The specific oxygen pulse is then defined as the  $O_2$  pulse expressed in units of its value at zero swimming speed.

$$\text{i.e. specific } O_2 \text{ pulse} = \frac{\text{Actual } O_2 \text{ pulse}}{O_2 \text{ pulse at zero (V/L)}}$$

The specific  $O_2$  pulse as calculated from equation (4) is plotted against swimming speed in figure 59 at both experimental temperatures. It can be seen that  $O_2$  pulse increases throughout the range of swimming speeds up to critical speed. The inflections in the lines are due to the discontinuous relationship used in the analysis of heart rate and the slight discrepancy between critical speed as defined and the point at which mean maximum heart rate is reached.

Sutterlin (1969) suggested that the relationship between heart rate and swimming speed in brown trout assumes a sigmoid form. The general pattern of increase in heart rate observed in the current experiments confirms this view, but using graphical methods (Ricklefs 1967) none of the commonly used growth-type curves would fit satisfactorily so the discontinuous relationship was adopted with defined basal

and maximum heart rates.

At 6.5°C there was no change in heart rate until a speed of about 0.6(V/L) was reached when the O<sub>2</sub> pulse was 1.5 times the resting value. Then both O<sub>2</sub> pulse and heart rate increased up to the critical speed at 1.5(V/L). At this point the recovery time curve (figure 19) rises steeply and it is assumed that both heart rate and O<sub>2</sub> pulse are maximal at speeds in excess of the critical. Actual energy expended in swimming continues to increase with increase in swimming speed and the resultant oxygen debt is reflected in the time taken for recovery after exercise at high speeds. At the critical speed heart rate increase had accounted for 39% of the estimated increase in oxygen transport and the specific oxygen pulse was 2.1.

In the experiments at 15°C the heart rate began to increase at 0.45(V/L) at a specific O<sub>2</sub> pulse of 1.36. At 2.0(V/L), the critical speed, the change in heart rate had accounted for 36% of the overall increase in estimated cardiac output and the specific oxygen pulse was 2.9.

#### THE GENERAL RELATIONSHIP BETWEEN HEART RATE AND OXYGEN CONSUMPTION.

The experiments on simultaneous determination of heart rate and oxygen consumption were designed to throw further light on the inter-relationship between these parameters. It was confirmed that the relationship between heart rate and oxygen consumption is in fact quite close to that which was predicted from the heart rate/swimming speed relationship using oxygen consumption figures from the literature. This implies that any relationship between heart rate and oxygen

consumption is not greatly affected by muscular swimming movements. There was a considerable scatter in the results (figures 26 and 27) but the deviations in individual cases could not be correlated with any obvious presence or absence of activity during the period of recording.

It is evident that large changes in oxygen pulse can take place in rainbow trout so that, particularly at medium and low oxygen consumptions, a wide range of options in heart rate/O<sub>2</sub> pulse combinations presents itself to the fish in order to attain any particular rate of oxygen transport. The options lie within the irregular quadrangle in figure 27 which is also reproduced in figure 60. Some degree of aggregation of the points does occur towards the diagonal line suggesting some sort of optimisation of cardiac performance. From the experimental results there is a highly significant relationship between heart rate and oxygen consumption at 15°C:-

$$\text{LogHR} = 0.4393 \text{ LogO}_2 + 0.8171 \quad (6)$$

where HR = heart rate beats/minute

O<sub>2</sub> = oxygen consumption mg/kg/hr

$$\text{or } \text{LogO}_2 = \frac{\text{LogHR} - 0.8171}{0.4393} \quad (7)$$

$$\text{taking antilogs } O_2 = \frac{(\text{HR})^{\frac{1}{0.4393}}}{(6.563)} \quad (8)$$

$$O_2 = \frac{0.0138 \text{HR}^{2.2763}}{1} \quad (9)$$

$$\text{By definition } O_2^{\text{pulse}} = \frac{O_2}{60 \text{ HR}} \text{ mg/kg} \quad (10)$$



Figure 60. The relationship between heart rate and oxygen consumption. The experimentally derived relationship compared with other simplified approximations described in the text.

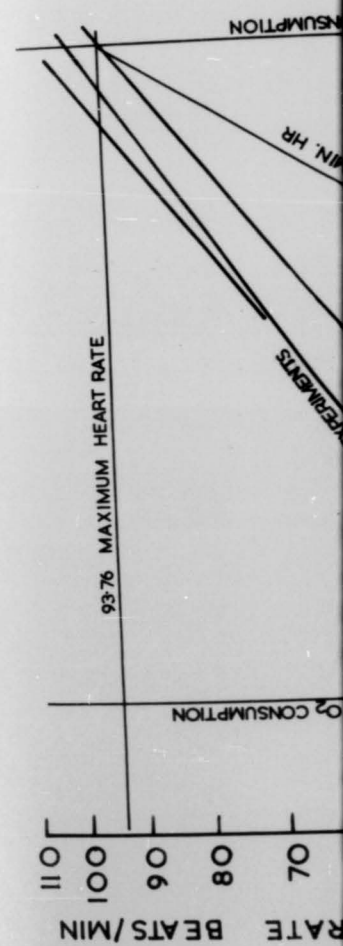

heart rate and  
experimentally  
pared with  
ations

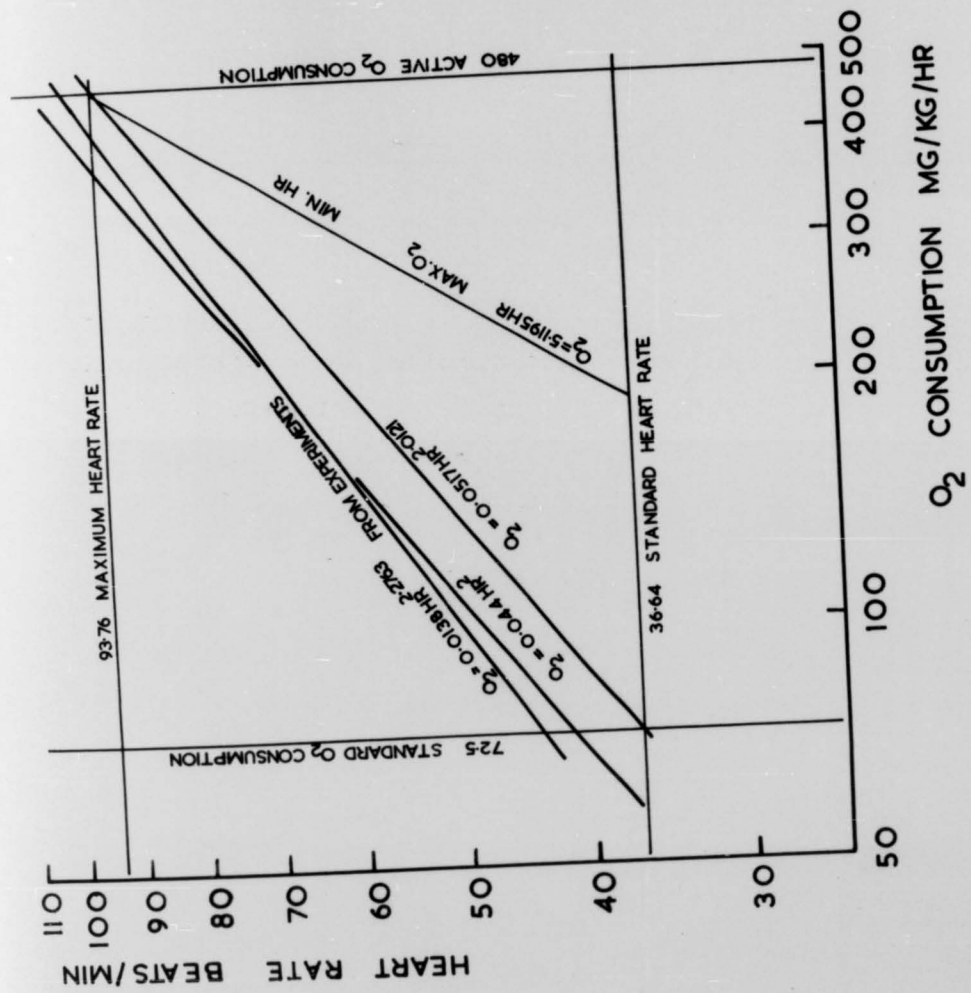

PL.

5/1

Figure 61. The relationship between  $O_2$  pulse and heart rate.  $O_2\text{pulse} = 0.00023\text{HR}^{1.2763}$  is the experimentally derived relationship and is compared with a simple linear approximation.

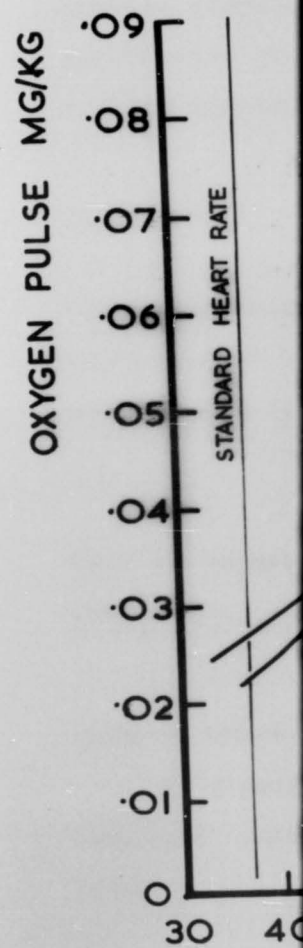

$O_2$  pulse and  
 $.00023HR^{1.2763}$  is  
d relationship  
mple linear

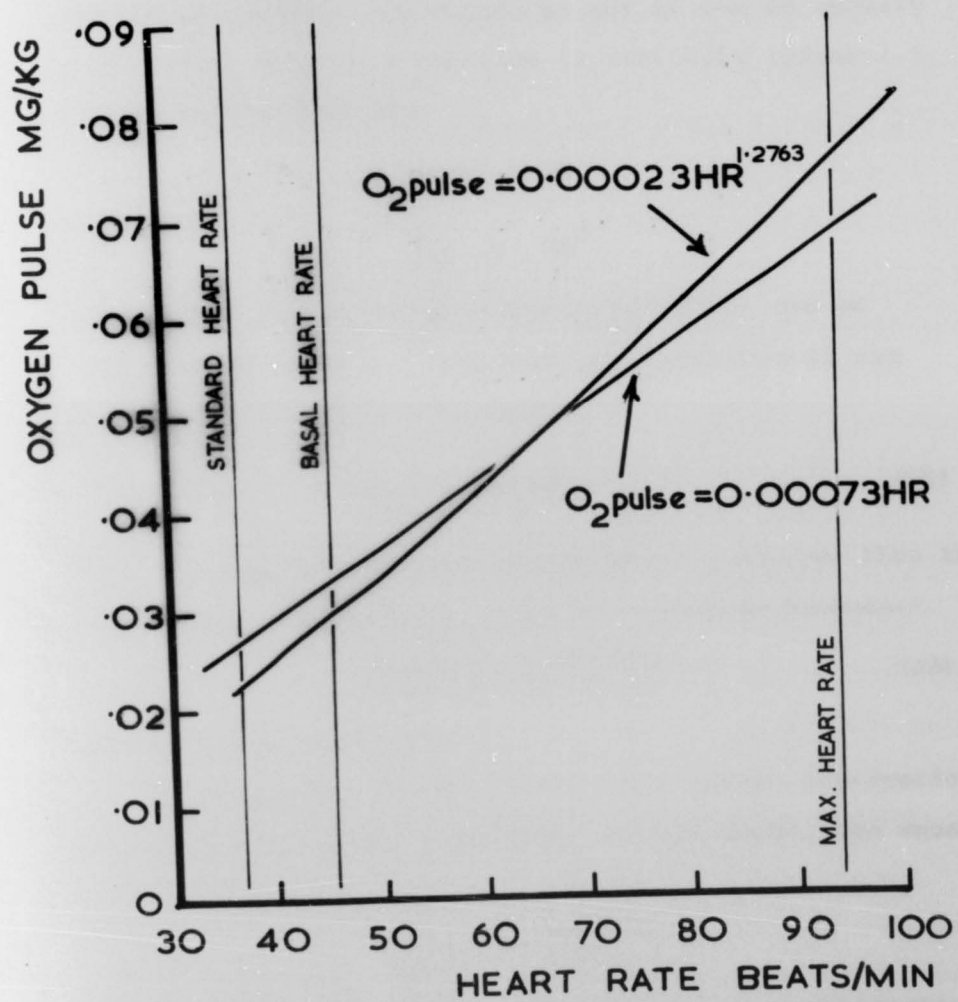

PL.

S/T

Therefore 
$$O_2 \text{ pulse} = \frac{0.0138 \text{HR}^{2.2763}}{60 \text{HR}}$$

or 
$$O_2 \text{ pulse} = \frac{0.00023 \text{HR}^{1.2763} \text{ mg/kg}}{1} \quad (11)$$

This relationship between  $O_2$  pulse and heart rate is plotted graphically in figure 61 and it can be readily appreciated that this function is virtually linear i.e. to a close approximation:-

$$O_2 \text{ pulse} \propto \text{HR}$$

Then

$$O_2 \propto \text{HR}^2$$

Examining equation (9) the exponent (2.2763) can be approximated to 2.0. The best approximation if the exponent is fixed at 2 becomes:-

$$O_2 = 0.044 \text{HR}^2 \quad (12)$$

This is compared with the experimentally derived line in figure 60. The oxygen pulse relationship becomes:-

$$O_2 \text{ pulse} = 0.00073 \text{HR} \quad (13)$$

This is shown in figure 61.

In figure 60 the diagonal of the oxygen consumption and heart rate scope quadrangle is also shown, the equation being

$$O_2 = 0.0517 \text{HR}^{2.0121}$$

Which also corresponds closely to a square relationship between oxygen consumption and heart rate.

The increase in  $O_2$  pulse from standard to maximum heart rate in the respirometry experiments is 3.3 using the statistically derived  $O_2/HR$  relationship, and 2.6 using the  $O_2 \propto HR^2$  approximation. These correspond quite closely to the maximum specific  $O_2$  pulse (2.9) determined in the  $15^\circ C$  swimming experiments.

It is evident that changes in the  $O_2$  pulse are important in varying the oxygen transport capability of the blood system. Stevens & Randall (1967b) measured dorsal and ventral aorta  $PO_2$  in rainbow trout swimming at moderate speeds and found no significant changes during or after exercise. Thus unless there are large changes in blood oxygen carrying capacity the  $O_2$  pulse corresponds closely to changes in stroke volume. It is probable therefore that cardiac stroke volume is proportional to heart rate. This would suggest that a relatively simple mechanism of control of cardiac output can be envisaged. However Bennion (1968) has shown that adrenaline can have different effects on heart rate and stroke volume in rainbow trout. At  $15^\circ C$  stroke volume is increased and heart rate decreased by increases in concentrations of adrenaline. Also during hypoxia (Holeton & Randall 1967) decrease in heart rate is offset by increase in stroke volume. Therefore any tendency to a constant ratio between stroke volume and heart rate appears to be readily modified. It is highly probable that much of the observed variation in the relationship between heart rate and swimming speed is due to changes in the stroke volume-heart rate relationship.

The Root and Bohr effects on the blood oxygen dissociation curve can be quite large (Randall 1970, Eddy 1971) which could radically alter the blood oxygen carrying capacity. It is difficult to estimate the magnitude of changes that are likely to occur due to metabolites such as lactic acid in the blood, but Holeyton & Randall (1967) obtained an oxygen capacity value of 9.00 vol.% and Irving, Black and Safford (1941) a value of 13.8 vol.%. A change in oxygen capacity from 13.8 vol.% to 9.00 vol.% would require a 50% increase in heart rate in order to maintain a given rate of oxygen transport. These effects are particularly likely to become evident during swimming at high speeds or recovery when oxygen debt has been incurred. After exercise at high speeds anomalies in the respiratory quotient are likely to occur as carbon dioxide is expired in a series of complex interactions in the blood pH-carbonate-buffering system associated with the release of lactic acid (Morgan 1973). High heart rates are then likely although oxygen consumption may be quite low. Due to the possible variations in the mechanical function of the heart and changes in the blood it is hardly surprising that in individual fish often no significant correlation between heart rate and oxygen consumption could be found.

In general terms it can be assumed that the mean changes in  $O_2$  pulse in the present study correspond closely to changes in cardiac stroke volume. On this basis the cardiac stroke volume approximately doubles at  $6.5^{\circ}C$  and approximately trebles at  $15^{\circ}C$  between minimum and maximum

This is rather smaller than the five-fold increase estimated by Stevens & Randall (1967b). In their experiments the increase in oxygen consumption was rather high for the low swimming speeds attained which could elevate the estimate of stroke volume change based on the Fick principle. Also the present estimate in the swimming trials is very sensitive to changes in the assumed  $b$  value; larger values such as that obtained by Webb (1971b) would yield larger changes in the stroke volume.

From the present respirometer experiments a general and simple relationship has been derived between oxygen consumption and heart rate, so the question arises as to the reasons for a discontinuous relationship between heart rate and swimming speed. In fish respirometry studies (Fry 1957) problems have been encountered in establishing a basal metabolic rate analogous to that used in human and mammalian physiology. This is largely, to express it simply, because fish cannot be persuaded to lie still. Therefore the convention has been adopted to determine metabolic rates at different known levels of activity and to extrapolate a series of these measurements to zero activity. This extrapolated value is defined as the standard metabolic rate. Brett & Glass (1973) point out that in tunnel respirometer experiments on Sockeye salmon, velocities below 0.5 to 1.0 (V/L) were useless because metabolism from spontaneous activity was usually in excess of that from the low imposed velocities. Thus in this and other respirometry studies the measurements at low velocities are excluded



when fitting a line for extrapolation to standard metabolic rate. It is this convention in effect which has been followed in the current work in calculating the regression line between the basal and maximum heart rate. The lowest swimming speed used in the regression line (about 0.5 (V/L) is the lowest water velocity in which the fish would swim uniformly. On this basis the regression line only was used in the calculation of predicted oxygen consumption/heart rate relationships (fig. 26).

The observed mean basal heart rate was above the standard heart rate. The standard heart rate (or metabolic rate) is by definition the heart rate (or metabolic rate) at zero swimming velocity and consequently the lowest possible mean heart rate for a fish. In a real situation with a fish at rest, the heart rate may be close to the standard rate but any deviation from this must necessarily be towards a higher heart rate. Thus over a series of experiments the mean basal heart rate (or metabolic rate) will always be in excess of the standard. To a certain extent therefore the basal heart rate plateau in the heart rate/swimming speed relationship (figures 18 and 22) reflects a real change in the oxygen consumption characteristics which is often ignored in the derivation of general metabolic relationships such as that of Brett & Glass (1973).

#### EFFECT OF TEMPERATURE.

The general heart rate and swimming speed relationships at the two temperatures have already been discussed but some comment can be made on the actual values of the

different heart rates. The  $Q_{10}$  for the temperature effect on the heart rate between  $6.5^{\circ}\text{C}$  and  $15^{\circ}\text{C}$  was 1.95 for the maximum, 1.65 for the basal heart rate and 1.99 for the standard heart rate. These values are lower than those found in experiments on relatively rapid changes in temperature in Ophiodon elongatus (Stevens et al. 1972), Cyprinus carpio and Barbus fluviatilis (Labat 1966) where  $Q_{10}$ s of up to 5 are common. This confirms that acclimation to temperatures takes place in terms of heart rate as well as metabolic rate.

Dickson and Kramer (1971) measured active and standard metabolic rates in the rainbow trout acclimated to  $5^{\circ}$ ,  $10^{\circ}$ ,  $15^{\circ}$ ,  $20^{\circ}$  and  $25^{\circ}\text{C}$ . In hatchery fish the active oxygen consumptions were 384mg/kg/hr and 576mg/kg/hr at  $5^{\circ}\text{C}$  and  $15^{\circ}\text{C}$  respectively ( $Q_{10} = 1.5$ ). The standard oxygen consumptions were 36 and 78mg/kg/hr at  $5^{\circ}\text{C}$  and  $15^{\circ}\text{C}$  ( $Q_{10} = 2.16$ ). The  $Q_{10}$  for standard heart rates in the present study corresponds quite closely to this standard oxygen consumption  $Q_{10}$  but the maximum heart rate increases rather more than the active oxygen consumption.

The  $Q_{10}$  is a crude means of comparison of rates at different temperatures but is of interest to note from the limited data available that in general changes in heart rates with temperature are of the same magnitude as corresponding changes in oxygen consumption.

#### EFFECT OF FEEDING AND STARVATION.

The high heart rates found in the fish with a stomach full of food are probably due to high oxygen consumptions. That

oxygen consumptions can be elevated due to food in the gut has been noted previously (Beamish 1964) and it has become usual to starve fish prior to measurement of standard oxygen consumption in order to obtain uniform results. The mean heart rate of fish 26 (fig 24) with a full stomach was approximately 73 beats per minute which using equation (12) gives:-

$$O_2 = 0.044 \times 73^2$$

$$O_2 = 230\text{mg/kg/hr}$$

This is approximately 3.5 times the standard oxygen consumption. Beamish (1964) obtained oxygen consumptions in fed fish of 3.0 times the standard in brook trout (Salvelinus fontinalis) at 10°C and values from under 2.0 times to 5 times the standard in the White Sucker (Catostomus commersoni) according to the temperature and season. Muir & Niimi (1972) measured corresponding values of 3 to 4 times the standard in aholehole (Kuhlia sandvicensis) when fed to satiation. Thus it seems that the high heart rate in fish 26 can be attributed to a high metabolic rate, when the stomach is full, due to effects such as specific dynamic action (Muir & Niimi 1972). By 48 hours after the last meal the heart rate in fish 26 had fallen to normal values which corresponds to the sort of time scale for oxygen consumption to decline during the stages of initial starvation (Beamish 1964, Muir & Niimi 1972, Glass 1968).

Throughout the heart rate work it was found that at a given temperature the maximum heart rates were remarkably constant. The only exception to this was fish 28 which was in poor condition and had probably effectively starved for some time and had low heart rates. This may have been due to a low metabolic rate but there is little evidence that this is so. Fry (1957) reports that rainbow trout starved for 100 days at 11°C did not have significantly different active metabolic rates from a fed control group of fish. Beamish (1964) shows that standard and routine metabolic rates fall rapidly in the first few days of starvation; subsequently there was no further decrease in the standard level although routine oxygen consumption continued to decrease. Glass (1968), Muir & Niimi (1972) and Dickson & Kramer (1971) all confirm this view and it seems that no further fall in metabolic rates can be expected in fish starved for periods longer than five days. Thus in theory some of the normal group of fish which were observed under experimental conditions for up to six days almost certainly had the lowest possible metabolic rates. The metabolic rate of fish 28 is unlikely to have been lower than that of some of the normal fish and the lower heart rate must have been due to some more complex effect such as a direct effect of starvation on the myocardium. In view of the uncertain history of fish 28 comment is probably best confined to a statement that fish in very poor condition may exhibit abnormally low heart rates the precise reasons for which are obscure.

The Role of the Vagus Nerve in the Control  
of Cardiac Function during Activity

INTRODUCTION.

Three kinds of nerve fibres may be found in the cardiac branch of the vagus; cholinergic inhibitory elements, adrenergic excitatory fibres and afferent sensory fibres. The evidence in the literature on the latter two is sparse but the inhibitory function of the vagus is well established.

In this thesis the role of the vagus nerve in cardiac regulation was investigated by sectioning the nerve in some fish for comparison with their intact counterparts. In order to provide controls in case the surgical intervention itself had an effect independent of removal of nerve function, one fish at each temperature was vagotomised on one side only with a sham operation on the other side. At 6.5°C the unilaterally vagotomised fish was in no way significantly different from the intact fish. At 15°C all the cardiac responses were normal except that the basal heart rate was significantly lower. However this resting rate (37.26) was not lower than the standard heart rate of the intact fish (36.64) so the rate was one which might be expected in a particularly placid fish. Basal heart rates of the same order were also recorded in intact fish. Basically it seems that the operation and the subsequent recovery period had no effect on the fish which could obscure interpretation of the data from vagotomised fish.

CHOLINERGIC INHIBITORY INNERVATION.

Von Skramlick (1935) reviewed much of the early work on fish circulation and proposed the general principle that

in fish due to the absence of a sympathetic innervation to the heart it is controlled largely by inhibitory effect of the vagus which works in antagonism to an intrinsic tendency for cardiac acceleration. It is now generally accepted that acetylcholine is the transmitter substance in this parasympathetic inflow to the fish heart (Campbell 1970) although Jullien & Ripplinger (1957) presented evidence showing that the actual substance is probably not acetylcholine but something very similar.

The high heart rates in vagotomised fish at 6.5°C (fig. 18B & table I) are what might be expected from the work of Von Skramlick when the inhibitory effect of the vagus is removed. The irregularity in the heart beat in intact fish (fig. 16a) may be evidence of modulation of a continuous inhibitory tonus as suggested by Labat (1966). This fluctuation in tonus may be linked with the synchronisation of heart beats with breathing movements but Randall & Smith (1967) have shown that in trout in well oxygenated water there is no such synchrony.

In contrast to the very regular heart beat in vagotomised trout in this study and the vagotomised carp of Labat (1966), Jullien & Ripplinger (1957) found that in tench vagotomy gave rise to a slow and arrhythmic heart beat which returned to regularity after atropine treatment. They suggested that in vagotomised fish tonically active vagal postganglionic cells inhibit the heart muscle and that normally these neurons are inhibited by pre-ganglionic neurons. Laurent (1962) and Gannon (1971) have also demonstrated the presence of postganglionic cells in the cardiac nerve.

At 15°C bivagotomy had no effect on the general patterns of change in heart rate. The only significant difference from intact fish was the lower maximum heart rate (Fig 22B, Fig. 23, table I). This lowered maximum heart rate may be attributable to inhibitory post-ganglionic neurons but no cardiac arrhythmias of the type noted by Jullien & Ripplinger (1957) were observed in the vagotomised fish.

The normal heart rates in the bivagotomised fish at 15°C gives rise to the paradox that the intrinsic heart rate (in the absence of vagus function) is higher at 6.5°C than 15°C. Bennion (1968) showed by *in vitro* studies on the trout heart that at 6°C adrenaline had a tachycardiac effect whereas at 15°C this effect was absent although stroke volume was increased. Thus the catecholamines which are likely to be released into the circulation during disturbance in the experimental situation could elevate the heart rate at 6.5°C but have no effect on heart rate at 15°C. Thus it is suggested that the high resting heart rates at 6.5°C were due to high levels of circulating catecholamines. This effect would gradually decline as the fish became used to the apparatus which would explain the observed gradual fall in heart rate. The tachycardia which can be very readily evoked by the slightest disturbance may be due to renewed secretions of catecholamines. In the intact fish these effects would presumably be masked by the bradycardiac effect of the vagus.

In the resting vagotomised fish at  $6.5^{\circ}\text{C}$  the heart rate was not maximal and some increase was observed during exercise. These increases must have been of aneural origin possibly again due to catecholamine secretion during activity as observed by Nakano & Tomlinson (1967). At  $15^{\circ}\text{C}$  it is evident that a large degree of cardiac regulation can take place in the absence of vagus function (fig. 23). Some adaptation to the vagotomised condition may have occurred during the period of recovery from the operation (Labat 1966). However this result at  $15^{\circ}\text{C}$  confirms the findings of Stevens and Randall (1967a) who found no effect on the changes in heart rate during swimming rainbow trout when the inhibitory function of the vagus had been blocked by injection of atropine. They conclude that there is no continuous vagal tonus to the heart in rainbow trout; their experiments were carried out at  $10^{\circ}$  to  $12^{\circ}\text{C}$  and they did not take the fish up to the maximum sustainable speed.

Throughout the experiments on intact fish short periods of cardiac inhibition were often observed, in response to external stimuli (figure 9) or during activity such as feeding (figure 25). These effects were abolished by vagotomy and were taken as evidence of the success of the operation (Labat 1966). Most authors who have worked on fish circulation have noticed this phenomenon and Lutz (1930) points out that in the dogfish reflex cardiac and respiratory inhibition can be evoked by sensory stimulation of almost every part of the fish. Despite having been described long ago



(McWilliam 1885, Mills 1886) the functional significance of these cardiac inhibitions remains obscure. Lutz (1930) suggests that this may be an emergency function in case of injury especially in the gill region. Johansen & Martin (1965) in their review suggest that it may be of importance in providing protection for the thin-walled gill vessels during periods of increased pressure in the branchial region. Many of the stimuli which evoke cardiac inhibition such as a rise in branchial arterial blood pressure (Mott 1951) and low buccal cavity  $PO_2$  (Randall & Smith 1967) are of physiological significance and would play a role in regulation of circulation. Phenomena such as the cardiac inhibition during feeding may be a purely incidental result of the simplicity of the control system.

#### EXCITATORY INNERVATION.

It has been generally accepted for over a century that the fish are unique among vertebrates in lacking sympathetic innervation to the heart. Gannon & Burnstock (1969) point out that this view has persisted despite numerous observations in the literature of reflex cardioacceleration in intact fish which were usually explained in terms of modulation of the vagal inhibition.

Using fluorescent histochemical techniques Gannon & Burnstock (1969) have demonstrated an adrenergic innervation of the heart in trout from fibres running in the vagus nerve.

They also demonstrated that electrical stimulation of the vagus could cause cardiac excitation or inhibition according to the pulse frequency used. Campbell (1970) reviews this and other scattered evidence and concludes that there probably is a cardiac excitatory function of the vagus and that the adrenergic fibres originate from the sympathetic ganglia. Gannon (1971) has carried out further detailed studies on the excitatory innervation in rainbow trout and demonstrates a similar adrenergic cardiac innervation in the eel (Anguilla australis).

More recently Cobb & Santer (1972) also found that stimulation of the vagus in plaice could cause cardiac excitation as well as inhibition. Santer (1972) applied the histochemical techniques to the plaice heart that were used on the trout by Gannon & Burnstock (1969) and Yamauchi & Burnstock (1968). He could find no evidence in plaice of adrenergic elements as demonstrated in trout and concluded that the stimulatory effect of the vagus in plaice is cholinergically mediated. Saito (1973) found cardiac excitatory effects during and after vagus stimulation in the carp. These effects together with the more typical inhibitory effects were abolished by atropine which again suggests a cholinergically mediated acceleratory mechanism. There was no evidence of sympathetic innervation of the cardiac pacemaker fibres and Saito suggested that the excitatory phenomenon was caused by effects associated with the deterioration of the experimental preparation. It seems probable that there are great interspecific differences in the autonomic nervous system of fish and this may be at the root of much of the controversy regarding sympathetic

Figure 62. Dissection from the ventral aspect of part of the right sympathetic cord. The cords run on either side of the dorsal aorta in the trunk region and in the cranial region a series of ganglia are connected with the cranial nerves. This dissection shows that the ramus communicans to the vagus nerve is very close to the cranium.

FLOOR OF  
CRANIUM

SYMPATHETIC  
GANGLIA

DORSAL  
AORTA

ral aspect of  
hetic cord.  
side of the  
k region and  
series of  
h the cranial  
n shows  
ns to the  
e to the

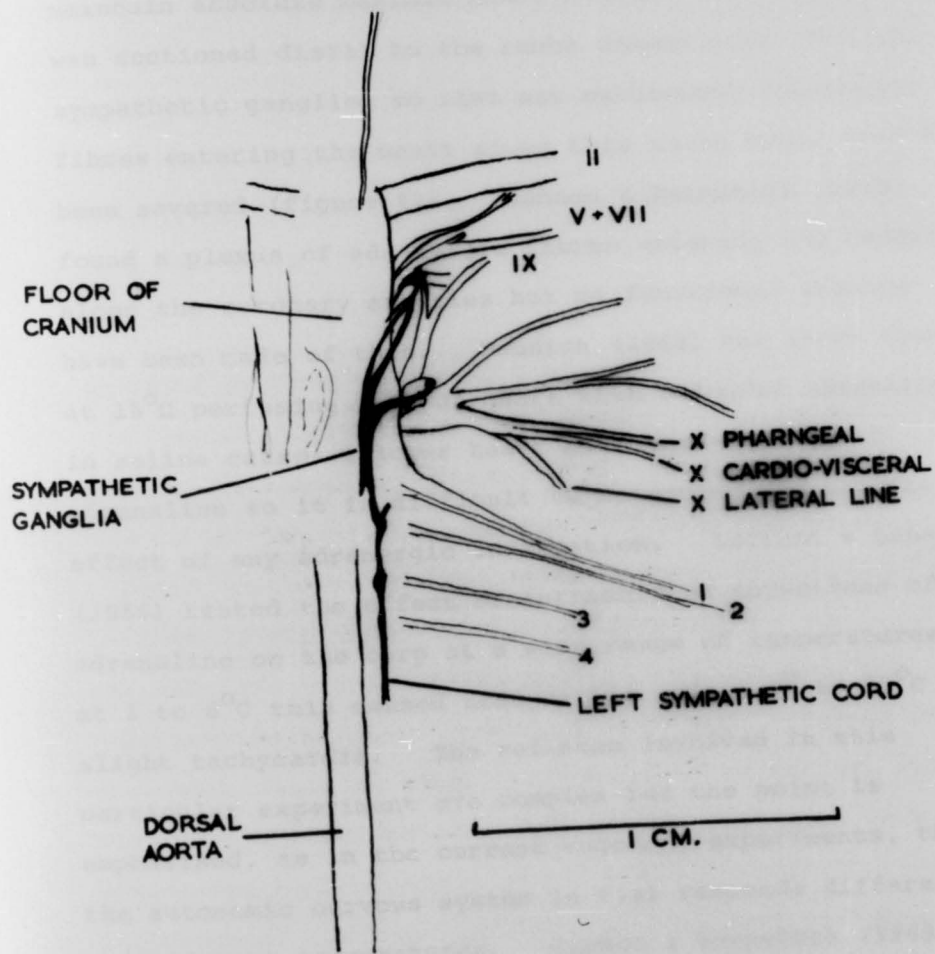

innervation of the heart.

In the present work the low maximum heart rate in vagotomised fish at 15°C may be evidence of a stimulatory function of the vagus which is required in order to maintain absolute maximum heart rates. The vagus nerve was sectioned distal to the ramus communicans from the sympathetic ganglion so that any excitatory adrenergic fibres entering the heart along this route would also have been severed (figure 62). Gannon & Burnstock (1969) found a plexus of adrenergic fibres entering the ventricle along the coronary arteries but no functional studies have been made of this. Bennion (1968) has shown that at 15°C perfusing a trout heart with 0.1 µg/ml adrenaline in saline causes a lower heart rate than 0.01 µg/ml adrenaline so it is difficult to determine the precise effect of any adrenergic innervation. Laffont & Labat (1966) tested the effect of intracardiac injections of adrenaline on the carp at a wide range of temperatures; at 1 to 8°C this caused bradycardia and at 9° to 20°C a slight tachycardia. The reflexes involved in this particular experiment are complex but the point is emphasised, as in the current vagotomy experiments, that the autonomic nervous system in fish responds differently at different temperatures. Gannon & Burnstock (1969) carried out their work on a trout heart preparation at 7° to 15°C and Gannon's (1971) experiments on trout were at 8° to 11°C. As both these works demonstrated cardiac excitatory effects in the trout heart it seems probable that at both 6.5°C and 15°C some degree of cardiac excitatory function of the vagus can be expected.

The evidence that (fig. 24) starved rainbow trout may have low heart rates suggests that the low maximum rate in vagotomised fish is due to the fact that these fish did not feed during the post-operative recovery period. The unilaterally vagotomised fish which went through exactly the same procedure had a normal maximum heart rate which counters this suggestion. Despite this, it is felt that before a continuous vagal excitatory effect during swimming can be postulated with certainty, detailed research is required on this phenomenon.

#### AFFERENT SENSORY INNERVATION.

Lutz (1930) showed that cardio-inhibition could be evoked by mechanical or electrical stimulation of the ventricle; a reflex which involved afferent as well as efferent pathways in the cardiac branch of the vagus. Laurent (1962) showed that the afferents in the cat-fish are relatively large myelinated fibres and that the efferents are fine non-myelinated fibres. Laurent carried out experiments on these two innervations and was able to show distinct pulses of afferent activity which were associated with specific events in the cardiac cycle. Inflation of the auricle elicited inhibitory efferent pulses to the heart and he suggested that this could form a response to increases in venous return which would reduce cardiac output and correct for the surge in blood flow. This reflex seems to work in opposition to the Starling's

law reflex intrinsic to the heart whereby output increases in response to increase venous return.

Randall (1966) could find no evidence of afferent activity in the vagus nerves of tench and goldfish although he was able to detect the efferent pulses to the heart. The precise nature of any afferent cardiac innervation in trout heart is obscure and the present experiments do not show any direct evidence as to its function. It is probably appropriate merely to note the possibility of an afferent component in discussing the role of the vagus in the trout.

#### STROKE VOLUME CONTROL.

In the above discussion of the vagus function only effects on heart rate have been considered. This has been partly to simplify the arguments and also because there is little information on stroke volume control by the vagus nerve. Under conditions of hypoxia in trout a bradycardia develops but stroke volume increases in such a way that only minor changes in cardiac output are observed (Randall 1970). This sort of effect and observations on stroke volume relations in the isolated heart (Bennion 1968) suggest that often stroke volume and heart rate are independently variable.

Stroke volume is very much dependent on venous return characteristics but it can be assumed that an inotropic effect on the heart would ultimately cause an increase in cardiac output. Jullien & Ripplinger (1957) in experiments on the tench showed that vagal stimulation has a negative inotropic effect which is a consequence of the negative

chronotropic effect. They also showed that a distinctly separate set of fibres in the vagus had a negative tonotropic effect which made the heart elongate. Campbell (1970) suggested that this latter effect was an artefact of the kymograph recording procedure used.

Jullien & Ripplinger (1957) found that the ventricle could only respond to stimulation by complete systoles; i.e. an "all or nothing" response due to the syncytial structure of the myocardium. This would suggest that the ventricular output is largely determined by the in flow of blood from the atrium which can respond to stimulation with differing forces of contraction. However Breton et al. (1964) obtained graded responses of the ventricle to different levels of stimulation the nature of which varied considerably according to how fresh the experimental preparation was.

The work of Gannon (1971) on rainbow trout is probably of most relevance to the present study. He electrically paced isolated atria and ventricles at low voltages which were of insufficient strength to stimulate intramural nerves. These intramural nerves could then be stimulated by increasing the voltage of the driving pulses. The effect of pharmacological agents could also be observed and the inotropic responses in the preparation beating at a constant rate were readily reproducible. The atria were shown to possess both cholinergic inhibitory and adrenergic augmentor innervations. The ventricles possessed only an adrenergic augmentor innervation and were insensitive to acetylcholine. There was also evidence of post-ganglionic inhibitory neurons which were stimulated by nicotine; this confirms some of the



observations of Jullien & Ripplinger (1957).

In general there is little evidence of distinct mutually independent cardiac chronotropic and inotropic effects of the vagus in fish; these two effects are probably simultaneous. This would tend to confirm the general relationship that stroke volume is proportional to heart rate which was found in the metabolic studies. There is no actual inhibitory innervation in the ventricle so its output is controlled to some extent by the flow of blood from the atrium which has a dual innervation. It seems that any apparent independence of heart rate and stroke volume is a function of the interaction between the heart chambers and the characteristics of blood flow, especially venous return.

#### Auxiliary pumps and their Influence on Circulation

The results of the experiments with vagotomised fish indicate that a considerable degree of cardiac regulation can take place in the absence of vagus function. This has directed attention to a consideration of aneural means of cardiac regulation.

Bennion (1968) carried out experiments on the in vitro heart of rainbow trout at 6°C and 15°C. He showed that the heart obeys Starling's law in that as the input (venous) pressure is raised stroke volume, heart rate and apparent stroke work increase. Any mechanism which could increase venous return would tend to increase cardiac output. Auxiliary blood pumping mechanisms which come into operation during swimming activity could explain some of the changes in heart rate during swimming.

## LYMPH PROPULSORS

Several propulsive mechanisms have been described in the lymph system which may ultimately contribute to the venous return flow. Marshall-Hall (1831) described the caudal heart in the common eel and noted that it pulsed at a rate of 160 beats per minute as compared with the pulmonary heart beat of 60 per minute. This appears to be the only quantitative information on the function of the caudal lymph heart; this figure being quoted by all subsequent authors up to Kampmeier (1969) who reviews the lymphatic system of fishes. Surveying the function of the caudal heart in different species Kampmeier concludes that the caudal heart is not independently pulsatile in trout and that it probably responds passively to the movements of the caudal fin musculature. Some early authors, Marshall-Hall (1831) and Owen (1866) state that the caudal heart of the eel pumps blood and indeed Owen uses the term "venous heart". Robin (1880) in a very detailed account definitely confirms that this organ in the eel pumps lymph as it does in salmonids. Grodzinski (1959) shows that the caudal lymph heart in sea trout is embryologically of venous origin and on its initial contractions during development empties itself of blood and becomes a lymph heart.

The volume of each lymph heart chamber (0.002ml from the present study) is of the same sort of size as reported in the Conger eel (Conger vulgaris) (Robin 1880). The estimated output of the caudal heart, assuming passive function with the tail beat at 2(V/L) is approximately 0.7ml/minute

as compared with a pulmonary cardiac output in the region of 30ml/minute (Stevens & Randall 1967b) (fig 41). Perhaps the most significant output of the caudal lymph heart might occur during a burst of swimming with a tail beat frequency of 15hz for example. Then the caudal heart output would be 0.03ml/sec. During a burst of swimming the pulmonary heart is often inhibited and would be working initially at the resting stroke volume of 0.15ml with about one beat per second. The extra 0.03ml in the venous return could contribute to a cardiac stimulation. In general however during swimming, blood pressure rises, plasma filters into the lymph system (Wardle 1971), the blood volume falls and haemoconcentration takes place (Stevens 1967). The flow of lymph from the caudal lymph heart is probably only significant in the context of relative lymph and blood volume regulation. In circumstances where large caudal heart outputs into the veins might be expected an increased reversed flow of plasma into the lymph system also occurs due to high blood pressures.

Other lymph propulsor mechanisms may be active in the cranial region (Kampmeier 1969) and the chambers of these sinuses are much larger than the caudal lymph heart. Any pumping action is probably linked with the breathing movements. In some fish these chambers exert a suction action on the lymph system drawing lymph forward along the rigid walled neural lymph duct (Wardle 1971). In salmonids the neural lymph duct is blocked and lymph return

must be through the flaccid peripheral lymph vessels which would restrict any suction effect. Wardle suggests that lymph return in salmonids is due largely to the high arterial pressure in these fish. It seems probable that no significant increase in venous pressure independent of pulmonary heart function could be attributed to function of propulsors in the lymph system except possibly in the initial stages of a burst of swimming activity.

#### DORSAL AORTA LIGAMENT.

In teleost fishes longitudinal ligaments have been observed immediately dorsal and ventral to the vertebral column. Franz (1898) in embryological studies on trout and salmon noticed that the *ligamentum longitudinale ventrale* lies within the lumen of the dorsal aorta. Burne (1909) observed the presence of the elastic ventral longitudinal ligament in the dorsal aorta of shad (*Alosa alosa*) and suggested that it may form the basis of a blood pumping mechanism linked with the fish's swimming movements (fig. 37). Antoniu-Murgoci (1940) describes the aortic cord or ligament in Acipenserids and states that it is made up of elastic fibres and is highly mobile. De Kock & Symmons (1959) described the longitudinal ligaments in herring and discussed the possible circulatory function of the ventral ligament in the aorta in terms of Burne's hypothesis. Dornesco & Santa (1963) give a description

of the structure of the dorsal aorta in the carp. They found a median septum attached to the dorsal wall of the aorta which projected into the lumen but not further than 20 to 30% of the diameter. The depth of this ligament or septum varied being deepest where it connected two adjacent vertebrae. The ventral longitudinal ligament in carp thus does not divide the lumen of the aorta and its main function seems to be as a structural component of the vertebral column.

The ligament is not present in the dorsal aorta of pike or perch. Observations of the presence or absence of the ligament in the dorsal aorta of different fish are sparse so no reliable comment can be made on its phylogeny. In considering its function it should be noted however that many fish do not have this structure in their dorsal aorta.

The present study has shown that a characteristic of the Burne mechanism is that the pump output is directly proportional to the tail beat frequency (figure 41). The theoretical output is somewhat larger than the estimated cardiac outputs but the discrepancy may not be significant. Maximum cardiac output and blood flow is reached at the critical swimming speed. During swimming above this speed the output of the Burne type pump would tend to far exceed the cardiac output. This would result in massive pressure oscillations unless the pump mechanism breaks down. It was shown that the pressure at which spontaneous breakdown would occur in a Burne type pump is very high. It is possible that a specific mechanism may alter the curvature of the vertebral column to take the ligament out of its

operative position with an effective seal against the ventral wall of the aorta. The onset of white muscle activity during swimming at high speeds may act in this way.

It was concluded from the theoretical analysis that an efficiently functioning Burne type pump over the full range of swimming speeds is probably undesirable. The experiments with the fish-bending machine, although unsatisfactory in many ways, showed no positive evidence of pumping activity in a trout cadaver. This, and close investigation of the aorta perfused with dyed saline suggested that any pumping activity is probably inefficient.

The dorsal aorta is rather more complicated than a simple tube in that the outflow is largely through lateral arterial branches and a taper along the length allows for this. The residual output through the caudal artery might be quite small and possibly difficult to measure with the techniques used in the fish bending experiments.

Assuming that the Burne type of positive displacement pump mechanism does not apply to the dorsal aorta of trout the ligament almost certainly does have some influence on blood flow. An impeller type of pumping action may take place with lateral accelerations being imparted to the blood. The position of the ligament against the lateral wall of the aorta on the inside curve of a swimming wave may inhibit retrograde flow from the segmental musculature as it contracts. The carp which does not have a ligament of this type has valves at the openings of the segmental arteries (Dornesco & Santa 1959) which may fulfill this

Figure 63. Model of the fish circulatory system  
(after Satchell 1971). CG -  
capacitance of the ventral aorta and  
afferent branchial arteries. CP -  
capacitance of the dorsal aorta and  
peripheral vessels.

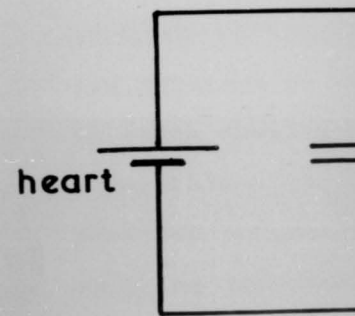

after

atory system  
CG -  
al aorta and  
ies. CP -  
l aorta and

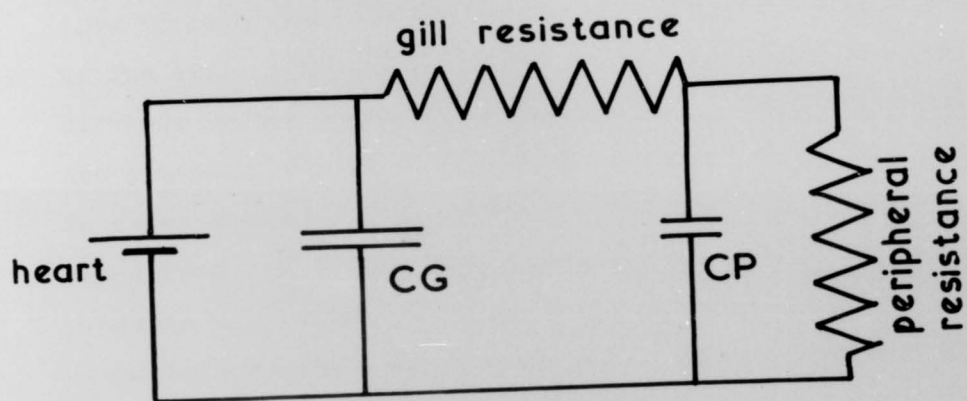

after Satchell (1971)

PL.



function.

During swimming, the movement of the ligament even if it does not have any directed pumping action is likely to impose pressure oscillations on the blood in the dorsal aorta. At anything above low swimming speeds these oscillations would be of a higher frequency than the heart beat. Satchell (1971) discusses the compliance effects in the arterial system of fishes using an electrical analogy. He points out that in order to maintain blood flow through gills the capacitance (compliance) efferent to the gills (CP) must be small relative to the capacitance afferent to the gills (CG). (figure 63). These capacitances are required to smooth the blood flow and pressure pulses. In trout despite the presence of the bulbus arteriosus capacitance, the smoothing of flow is not complete and the pressure pulses in the dorsal aorta increase during swimming (Stevens & Randall 1967). Using the electrical analogy further:-

$$r \propto \frac{1}{f R C} \quad (\text{Brophy 1966})$$

where

- r = ripple factor
- f = pulse frequency
- R = resistance
- C = capacitance

The movement of the dorsal aorta ligament is likely to effectively increase f and then r would decrease i.e. the pressure oscillations would decrease in amplitude.

This effect would be particularly advantageous as increase in CP, the dorsal aorta and peripheral capacitance, is restricted. The smoothing of the pressure oscillations would result in an increase in efficiency of exchange with blood in the muscle capillaries.

Despite these considerations the fact remains that the tension in the dorsal aorta ligament is far larger than is required for any blood circulatory function and any such role may be secondary to that as a structural component of the axial skeleton.

#### CONCLUSIONS.

Satchell (1971) discusses various auxiliary mechanisms of venous return in fish but most of the information is on elasmobranchs. Sutterlin (1969) described some valves in the veins of the caudal region of trout and showed that these may promote venous return during activity.

Considering all the possible auxiliary pumping mechanisms in trout which may come into play during swimming activity it seems that no large increase in venous pressure can be expected. However the heart responds to quite small increases in venous pressure e.g. an increase in input pressure from 2mm to 6mm Hg approximately doubles the cardiac output (Bennion 1968).

#### Functional Morphology of the Heart

##### BULBUS ARTERIOSUS.

One of the characteristic features of the anatomy of the teleost heart is the bulbus arteriosus which is distinguished from the conus arteriosus of the elasmobranchs

Figure 64. Diagrammatic longitudinal (A & B) and transverse (C & D) sections of the bulbus.



Figure 64. Diagramatic longitudinal (A & B) and transverse (C & D) sections of the bulbus.

PROBLEM

A

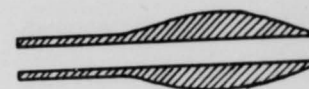

C

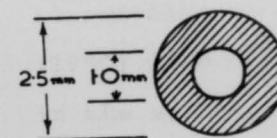

CIRCUMFERENCE

INNER 3.14

OUTER 7.85

## PROBLEMS IN WINDKESSEL DESIGN

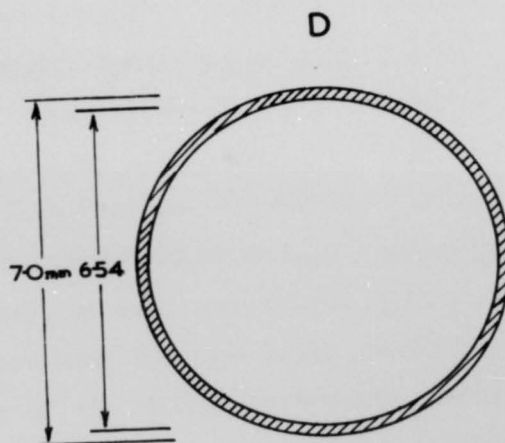
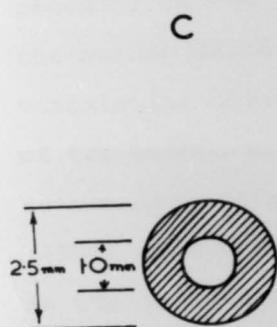
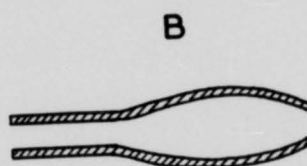
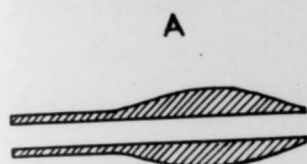

CIRCUMFERENCE  
 INNER 3.14 MM  
 OUTER 7.85 MM

CIRCUMFERENCE  
 INNER 20.55 MM  
 OUTER 22.00 MM

STRAIN  
 INNER 5.54  
 OUTER 1.80

(A & B) and  
 ons of the

PL.

by the nature of its walls and by the fact that it does not contract rhythmically (Parsons 1930). The myocardium does not extend into the bulbus which is made up of elastic and smooth muscle fibres and acts as a passive elastic chamber which helps to smooth the pressure pulse from the heart.

The windkessel function of the bulbus has been demonstrated in vivo particularly by Johansen (1962) and Stevens et al (1969). The intravascular pressure pulse during ventricular systole is converted to a slow rising pressure in the bulbus arteriosus. Elastic rebound of the bulbus maintains ventral aortic blood flow during ventricular diastole. This effect depends on the ability of the bulbus to expand elastically under pressure to accommodate relatively large volumes of blood. Mott (1950) made radiological observations on the circulation in the eel and noted that the most remarkable feature in connection with the heart beat was the large amplitude of changes in the diameter of the bulbus arteriosus (from 3mm to 5mm diameter).

In considering the design of a windkessel chamber certain problems become immediately apparent. Figure 64a shows a longitudinal section through a typical trout bulbus arteriosus and it is evident that if the elastic wall was of a uniform material the thick part in the bulbus region would not deform at all but the ventral aorta would dilate preferentially.. Figure 64 shows an alternative design with a uniform thickness. In this, due to the large diameter in the bulbus region and consequential larger tension in the

wall the bulbus would dilate as planned but as the diameter increased so the wall would become thinner and the possibility of a "blowout" arises. This system also has the disadvantage of a considerable "deadspace" or residual volume of blood when relaxed.

Figure 64 C and D show transverse sections of the bulbus of a 30 cm trout in the contracted and extremely expanded states respectively, if it is assumed that the wall is made of a uniform material. The strain on the fibres adjacent to the lumen is far larger than on the outer fibres. This is a basic problem if wall thicknesses are large compared with the radius. Returning to figure 56 it can be seen that in trout this problem is avoided by the fact that the inner fibres do not follow the outer ones as the bulbus expands. The inner longitudinal fibres arch outwards and help support the outer wall by connections with the radial fibres. If the radial fibres were exactly radially orientated their extensions would be very large but as they slope in the longitudinal axis this extension is minimised. It can be appreciated that the complex structure of the bulbus serves to equalise the strain in all the structural elements of the chamber wall. Collagen, a relatively inextensible material is confined to the outer layers where least extension takes place; this is typical of most blood vessels.

The amount by which the bulbus sustains flow in the ventral aorta during ventricular diastole can be estimated by assessing the volume change of the bulbus between systolic

and diastolic pressures. From figure 57, the bulbus pressure-volume relationship, the volume increase of the bulbus per mm Hg pressure increase is approximately 0.0013ml. This fish weighed 85gm so that assuming that the volume change is proportional to the weight of the fish the corresponding volume change in a 300 gm fish is:-

$$\frac{300}{85} \times 0.0013 = 0.0046 = 0.005 \text{ ml/mm Hg approximately}$$

This is approximately the size of fish used by Stevens & Randall (1967a, b) in their studies of the blood system during swimming in rainbow trout. The effect of the bulbus on flow can then be assessed using the blood pressure and cardiac output figures from that study.

At rest the ventral aorta systolic pressure was 40mmHg and the diastolic 32mm Hg.

Therefore pressure pulse = 40 - 32 = 8mmHg

Therefore the volume change in the bulbus = 8 x 0.005 = 0.04 ml

The corresponding cardiac stroke volume was 0.15 ml.

Therefore the proportion of flow in the dorsal aorta which takes place due to elastic rebound of the bulbus is:

$$\frac{0.04}{0.15} \times 100 = 27\% \text{ approximately}$$

At the highest swimming speeds studied by Stevens & Randall the ventral aorta systolic and diastolic pressures were 58 and 45 mmHg respectively.



Therefore the pressure pulse =  $58 - 45 = 13$  mmHg

Therefore the volume change in the bulbus =  $13 \times 0.005 = 0.065$  ml.

The cardiac stroke volume at this point was 0.70ml.

Therefore the proportion of blood flow due to bulbus rebound is:

$$\frac{0.065}{0.70} \times 100 = 9\% \text{ approximately}$$

Thus the bulbus arteriosus appears to be particularly important at low cardiac outputs in sustaining ventral aorta blood flow during ventricular diastole. Stevens et al (1969) by direct measurement of blood flow in Ophiodon elongatus showed that 29% of blood flow took place during this phase due to the action of the bulbus Arteriosus.

In the present work no account has been taken of the effects of the difference between the static and dynamic elasticity of the bulbus. In view of the few experiments carried out and assumptions used extending bulbus elasticity measurements on a small fish to much larger fish the above estimates can only be taken as an indication of the orders of magnitude involved. The smooth muscle in the bulbus could also modify the distensibility of the bulbus under different conditions. It is probable that the smooth muscle acts in a similar way to that of the ventral aorta studied by Kirby & Burnstock (1969). They showed that the ventral aorta of trout would contract in response to electrical stimulation and administration of catecholamines or acetylcholine.

The response to catecholamines was often absent and it was suggested that the ventral aorta smooth muscle tonus is largely cholinergically controlled in fish. Contraction took place over a period of about 30 seconds and relaxation took 5 to 10 minutes.

It has been shown that the trabeculae are probably an important functional feature of the bulbus arteriosus. However Gegenbaur (1866) points out that in teleost evolution there is a trend from the ridged to the smooth condition of the bulbus wall. Parsons (1930) states that in trabeculate forms the conus wall is very compact but that in the smooth types the bulbus wall is composed of a loose spongework through which there are many interstices. Parsons uses the term "trabeculae" to refer to prominent longitudinal ridges apparent in simple dissection of the bulbus. He regarded salmon as an intermediate form in that the anterior end of the bulbus is divided by trabeculae but at the base there is a transition to the smooth type. Re-examination of the cast of the trout bulbus (fig 52) shows that at the anterior end prominent longitudinal ridges are apparent but towards the base there is a spongy appearance where the radial fibres predominate. Haberich (1965) states that the demonstration of the trabecular structure of the heart is difficult since the meshwork immediately collapses upon dissection. The injection techniques used in the present study enable some relationships to be perceived which are otherwise difficult

to investigate. It is apparent from these studies that in the "smooth" regions of the bulbus wall the combination of many radial elements with the longitudinal fibres is an extension of the strain equalising features of the structure.

#### VENTRICLE

Johansen (1965) states that the most noticeable difference from most higher vertebrates in the ventricles of fishes and amphibians is the almost entire lack of a spacious central lumen. This was noted in the present study on trout; there being an outer compact muscle layer and an inner spongy mass. In amphibia it has been shown that the trabeculation is important in maintaining separation of venous and arterial blood. This function is obviously not required in fish so underlying mechanical reasons for trabeculation must be considered. Johansen and Hol (1964) maintained that the myocardial arrangements in lower vertebrates facilitates ventricular function by reducing strain on individual muscle fibres enabling contraction of a relatively small heart through large size ranges. A rigorous analysis of the ventricular function based on the Laplace Law intended by these authors does not appear to have been completed. Indeed the study of the dynamics of the heart as a muscle system in mammalian physiology continues to use approximations of simple geometry, isotropic wall material and uniform fibre arrangement (Talbot & Gessner 1973). Some progress has been made to analysis of a natural fibre arrangement in

the canine left ventricle (Streeter et al 1969).

By simple analogy the rather qualitative analysis of the bulbus structure can be applied to the ventricle. A fragmented structure of the inner muscle is important in reducing the strain on the individual fibres of the inner layers. The trabeculation tends to equalise the amount of extension in all the muscle fibres and then they can all contract at very similar velocities which would tend to increase efficiency. It seems possible that as the ventricle contracts the outer compact muscle layer would squeeze the inner spongy mass which would not be doing any useful work towards the end of systole. At low stroke volumes if the ventricular amplitudes are small, most of the work may be done by the compact muscle layers and any increase in stroke volume would involve progressive recruitment of the fibres of the spongy muscle as contractile amplitudes increase. Only the compact muscle layer receives a coronary blood supply and the spongy muscle is supplied by diffusion from the chamber cavity (Ostadal & Schlieber 1971). This raises the possibility of an interesting parallel with the swimming musculature where only the red muscle which works continuously for long periods has a good blood supply. However Ostadal and Schlieber showed that in many fish the outer compact layer is absent, this was related to weight rather than phylogenetic relationships. Fish with a small body weight have a myocardium consisting almost entirely of the sponge like mass with no outer compact layer or coronary vessels; the plaice is an example of such a fish (Santer & Cobb 1972).

It is also of interest to note that no adrenergic nerve supply reaches the plaice ventricle (Santer 1972). This may be associated with the lack of coronary blood vessels along which adrenergic fibres apparently reach the ventricle in trout (Gannon & Burnstock 1968).

It appears in general that the thick stratum compactum with a good coronary blood supply is correlated with an ability to pump at high rates with a relatively high blood pressure. The blood pressure in trout is rather higher than in plaice (Wardle 1971).

#### ATRIUM

The atrium has no outer stratum compactum which is probably correlated with the relatively low pressures generated by this chamber. The myocardium is diffuse probably again to provide for large amplitudes of contraction. The atrium must be readily distensible in order to be filled by the low venous return pressures. The pressures generated during atrial systole need only be large enough to dilate the ventricle. In the section on the role of the cardiac innervation it was pointed out that the atrium has a more sophisticated control innervation than the ventricle. It is possible that the ventricular output is determined largely by simple intrinsic responses to a controlled inflow from the atrium.

#### SINUS VENOSUS

The sinus venosus has a volume of about 0.08ml which when compared with the likely cardiac stroke volumes indicates that at low cardiac outputs it can store 50% of the stroke volume and at high cardiac outputs this falls to

about 10%. Thus during atrial systole the sinus cannot be just emptied into the atrium but considerable volumes of blood must be drawn from the major veins. The sinus venosus can hardly be regarded as a functional chamber of the heart in the sense that the atrium and ventricle alternately fill and empty passing on discrete volumes of blood. The sinus is little more than the confluence of the major veins. The venous pressure is always positive in rainbow trout (Stevens & Randall 1967a) and is sufficient to produce a regular flow of blood through the relatively narrow veins by a vis a tergo effect there being little evidence for a vis a fronte as in elasmobranchs (Satchell 1971).

#### Conclusions

In the course of these studies information has been accumulated on the changes in heart rate associated with different activities and metabolic rates. Nomura et al (1972) have telemetered ECG's from rainbow trout in hatcheries and were able to correlate heart rate with patterns of activity in raceways between ponds. Knowledge of the relationship between heart rates and metabolism could enable assessment of metabolic rates in free-living fish using this telemetric technique. Caution would have to be exercised in interpretation of results because the range of possible oxygen consumptions for a given heart rate is large. Minimum estimates of metabolic rates in free-living fish have been derived from telemetric studies of swimming activity (Holliday et al 1974) and laboratory studies of trout metabolism (Morgan 1974).

Using information on heart rates maximum oxygen consumption values could be accurately defined. Phenomena such as cardiac inhibitions which were observed by Nomura et al (1972) could provide a means of assessing the sensory input to the fish. Despite the variation in basal heart rates it should be possible from ECGs to quantify the effort expended in short bursts of activity. This could be done by observing the period over which maximum heart rate is sustained and the time for subsequent recovery when the fish is at rest. As a measure of metabolic rate, heart rate would have a large range of error if used for overall energy budget calculations but could provide useful information on short term changes. The effect of variation in environmental water temperatures and  $PO_2$  etc. would have to be taken into account.

In consideration of the control of circulation this study has assessed certain aspects of the overall picture (figure 1). The importance of the lymph volume has been demonstrated by Wardle (1971) but the present studies indicated that the flow rates returning to the veins are small relative to blood flow. Taylor et al (1968) developed a mathematical model to simulate the cardiovascular-respiratory dynamics of rainbow trout using largely the data of Randall & Stevens (1967 a,b.). In these equations they used a figure for the effective volume of the body compartment blood which was 1.5 times the total blood volume. The magnitude of this figure was

not very critical but this does suggest that fluxes between lymph and blood are of significance in short term (0.01 minute intervals) cardiovascular dynamics as well as in longer term blood volume regulation.

The fact that vagotomy had a different effect at different temperatures is of particular importance. Bennion (1968) noted complementary differences in the isolated trout heart at different temperatures. It seems that any work on the role of the autonomic nervous system and associated pharmacology must take into account the temperature. The study of fish physiology then appears to become disproportionately complex but some assessment of temperature as a variable in basic physiological processes is essential.

The model of Taylor et al (1968) predicts cardiovascular-respiratory changes during swimming and uses three controlling system equations:-

respiratory ventilation volume  $\propto$  fall in venous  $PO_2$

cardiac output  $\propto$  respiratory ventilation volume

effective gill area  $\propto$  change in cardiac output

They suggest that increase in metabolic rate reduces venous  $PO_2$  which via receptors in the veins entrains changes in ventilation volume, cardiac output and gill perfusion pathways. The model depends on monitoring venous  $PO_2$ ; no satisfactory simulation could be achieved using arterial or venous  $PCO_2$  or arterial  $PO_2$  as a feedback reference.



There is little anatomical or physiological evidence for receptors in the venous circulation. The most clearly demonstrated blood  $PO_2$  receptor site is in the pseudobranch (Laurent & Rouzeau 1972) which is in the efferent (arterial) circulation of the first branchial arch. Davis (1971) shows that the gill circulation of rainbow trout can be extensively manipulated without affecting circulatory and ventilatory responses unless the first branchial arch circulation was disturbed so as to divert blood away from the pseudobranch. The model of Taylor *et al* successfully predicts the behaviour of the cardiovascular system assuming continuous flow characteristics. However there is no reason to suppose that the control equations used are anything more than empirical descriptions of physiological events with no actual analogous control mechanisms being implied. The model clarifies certain aspects of respiratory exchange but as far as the control of cardiac output is concerned it is probably far too simple. For example, the pseudobranch gives rise to different efferent neural activity in response to various physiological parameters of the blood;  $PO_2$ ,  $PCO_2$ , pH, hydrostatic pressure, osmotic pressure and  $Na^+$  ions. (Laurent & Rouzeau 1972, Laurent 1967).

Vagotomy at  $15^{\circ}C$  had little effect on heart rates during exercise which suggests that there is considerable redundancy in the circulatory control mechanisms.

The possible role of auxiliary pumps increasing venous return was extensively discussed. It may be possible to explain the responses to exercise observed in vagotomised fish in terms of the effect of catecholamines circulating in the blood. Nakano & Tomlinson (1967) measured levels of catecholamines in blood and various tissues of rainbow trout during and after activity. It seems probable from this that catecholamines could be secreted rapidly enough to explain the increase in heart rate at the onset of exercise. It is however doubtful if they could be removed from the circulation rapidly enough to explain the rapid fall in heart rate after moderate exercise which occurs even in the absence of vagus inhibitory function (Figures 19 & 23). Catecholamines influence various parts of the circulatory system in such a way that observed changes in circulation can be explained in terms of their interaction with these receptor sites. (Randall & Stevens 1967). The fundamental problem remains that little is known of the mechanism controlling secretion or removal of catecholamines from the circulation. Nakano & Tomlinson (1967) point out that the fall in catecholamine concentrations in the anterior kidney was insufficient to account for all that appeared in the circulation. Either the rate of production equalled the rate of secretion or these substances were secreted elsewhere. There was some evidence that noradrenaline is secreted in the heart from the sympathetic system. Vagotomy excludes the possibility that this could be derived from fibres in the vagus in the present study but

the coronary adrenergic plexus (Gannon & Burnstock 1969) may be implicated. In the absence of any evidence of how catecholamine secretion is controlled, theories of circulatory homeostasis based on responses to injected drugs or the response of *in vitro* isolated preparations must remain essentially speculative. Anatomical and histochemical studies have been carried out on the chromaffin tissue in a shark (Gannon & Campbell 1972) and the plaice (Grove *et al* 1972) with a view to understanding its secretion into the circulation but no defined conclusions can be drawn which would be of direct application to rainbow trout. The role of catecholamines other than in the control of circulation is also a factor which should be considered e.g. the role of adrenaline in carbohydrate metabolism (Nakano & Tomlinson 1967, Wardle 1972).

Neurohypophysial and adrenal cortical hormones have vassopressor influences on the circulatory system and can affect blood flow patterns in the gills (Perks 1969, Rankin & Maetz 1971). However the primary importance of these hormones is probably in regulation of electrolyte exchange. In this connection the diversion of blood flow towards or away from the "chloride" cells of the gills by virtue of effects on the branchial vasculature may be of significance. Considerable fluxes of water and ions take place between the internal and external milieux in rainbow trout during swimming activity (Wood & Randall 1973 a,b,c.) and it is against this complex background (the details of which are outside the scope of the present thesis) that

endocrine influences on circulation must be considered.

Saunders and Sutterlin (1971) studied the effect of section of the IX and X cranial nerves on cardiac and respiratory responses to hypoxia in the Sea raven (Hemipterus americanus) and showed that this procedure had little effect on the observed responses. Section of the IX nerve also denervates the pseudobranch. In the case of hypoxia the responses may be explained by the activity of sensor "end buds" in the buccal cavity which are innervated by the V cranial nerve. (De Kock 1963). Efferent activity in the branchial elements of the V and VII nerves could account for changes in breathing. There was evidence of peripheral vasomotor reflexes involving autonomic pathways other than the IX and X nerves. The origin of the vasomotor supply to the ventral aorta in trout for example (Kirby & Burnstock 1969) has not been ascribed to any particular cranial nerve. It seems probable that sectioning only the cardio-visceral branch of the vagus has left many vasomotor pathways intact and the activity of these may explain some of the circulatory changes observed in the present work.

The work carried out on the anatomy of the heart did not extend to a full analysis of mechanical relationships of the structural elements that might be hoped for. In the context of overall cardiovascular function an estimate was made of the probable influence of the bulbus arteriosus on ventral aorta flow. The small estimated volume of the sinus venosus emphasises that any increase in cardiac output

is very dependent on increase in venous return. The heart cannot draw on blood stored in the sinus venosus in order to make a significant increase in output beyond one or two beats. A study of how the volume of each chamber of the heart varies at different rates of cardiac output would be of particular interest especially when considering the function of the ventricular myocardium with its two distinct layers. The simple static views obtained in the present study are of limited value as little is known of the mean amplitude about which the heart contracts at different stroke volumes. Radiological techniques such as those used by Mott (1950) and Johansen & Hol (1964) may be appropriate but observation of a perfused isolated heart would also be of value.

The amount of information available on circulatory physiology in fish is rapidly increasing each year and it is becoming possible to reach a general understanding of various phenomena. However as noted at several points in this thesis, interspecific differences between the fishes are great and generalisations are often inapplicable in particular instances. This is of great interest in comparative studies but when applying physiological knowledge in fish husbandry for example the characteristics of each species must be independently assessed. This thesis concentrated on rainbow trout on which much work has been carried out and numerous problems emerged; as attention is directed to some of the less well known species careful consideration must be given to the most efficient means of consolidation of information for the purpose required.

REFERENCES

- ALEXANDER, R.McN. (1968). *Animal Mechanics*. London: Sidgwick & Jackson.
- ANTONIU-MURGOCI, A. (1940). *Contributiuni la studiul Acipenseridelor diu Romiñia*. - Thèse-Jassy. cited by Dornesco & Santa (1963).
- ARNOLD, G.P. (1969). A flume for behaviour studies of marine fish. *J. exp. Biol.* 51, 671-679.
- BAINBRIDGE, R. (1958). The speed of swimming of fish as related to size and to the frequency and amplitude of tail beat. *J. exp. Biol.* 35, 109-133.
- BAINBRIDGE, R. & BROWN, R.H.J. (1958). An apparatus for the study of the locomotion of fish. *J.exp.Biol.* 35, 134-137.
- BALLINTJIN, C.M. (1969). Muscle co-ordination of the respiratory pump of the carp (*Cyprinus carpio* L.) *J.Exp.Biol.* 50, 569-591
- BEAMISH, F.W. (1964). Respiration of fishes with special emphasis on standard oxygen consumption. II. Influence of weight and temperature on respiration of several species. *Can.J.Zool.* 42, 177-194.
- BELL, W.N. & TERHUNE, L.D.B. (1970). Water tunnel design for fisheries research. Fisheries Research Board of Canada Technical Report No. 195.
- BENNION, G.R. (1968). The control of the function of the heart in teleost fish. M.Sc. Thesis University of British Columbia cited by Randall (1970).
- BERGEL, D.H. (1961). The static elastic properties of the arterial wall. *J. Physiol.* 156, 445-457.

- BLAŽKA, P., VOLF, M. & ČEPELA, M. (1960). A new type of respirometer for determination of the metabolism of fish in an active state. *Physiologia. Bohemoslov.* 9, 553-558.
- BRETON, D., CORABOEUF, E., DIETRICH, J. & OBRECHT, G. (1964) Activité mécanique cardiaque chez trois poissons; un sélacien, la petite roussette (Scyliorhinus canicula. L.); Deux téléostéens: Le congre (Conger conger, L.) et le muge (Mugil chelo, Cuvier). (Sommaton et tétanus; relation amplitude de fréquence contraction-fréquence, dépression ou potentiation post-stimulatives. *Bull. Cent. Etud. Rech. sci., Biarritz.* 5, 7-66.
- BRETT, J.R. (1964) The respiratory metabolism and swimming performance of young sockeye salmon. *J. Fish.Res.Bd. Can.* 21, 1183-1226.
- BRETT, J.R. & GLASS, N.R. (1973) Metabolic rates and critical speeds of sockeye salmon (Onchorhynchus nerka) in relation to size and temperature. *J.Fish.Res.Bd. Can.* 30, 379-387
- BROPHY, J.J. (1972). Basic electronics for scientists. 2nd. ed. McGraw-Hill.
- BURNE, N. (1909) Elastic mechanisms in fish and snake. 1. Ligamentum longitudinale ventrale of a Shad. (Clupea alosa). *Proc. Zool. Soc.* 201-203.
- BURNSTOCK, G. (1958). The effect of drugs on spontaneous motility and a response to stimulation of the extrinsic nerves of the gut of a teleostean fish. *Brit. J. Pharmacol.* 13, 216-225.
- CAMPBELL, G. (1970). Autonomic Nervous Systems. In *Fish Physiology*, (ed. W.S. Hoar & D.J. Randall) vol. IV pp. 109-132. New York: Academic Press.

- COBB, J.L.S. & SANTER, R.M. (1972). Excitatory and inhibitory innervation of the heart of the plaice (Pleuronectes platessa): anatomical and electrophysiological studies. *J. Physiol* 222, 42-43P.
- DAVIS, J.C. (1971). Circulatory and ventilatory responses of rainbow trout (Salmo gairdneri) to artificial manipulation of gill surface area. *J. Fish.Res.Bd. Can.* 28, 1609-1614.
- DE KOCK, L.L. (1963). A histological study of the head region of two salmonids with special reference to pressure and chemoreceptors. *Acta. Anat.* 55, 39-50.
- DE KOCK, L.L. & SYMMONS, S. (1959). A ligament in the dorsal aorta of certain fishes. *Nature, Lond.* 184, 194.
- DICKSON, J.W. & KRÄMER, R.H. (1971). Factors influencing scope for activity and standard metabolism of rainbow trout (Salmo gairdneri) *J. Fish.Res.Bd. Can.* 28, 587-596.
- DONALDSON, L.R. & OLSON, P.R. (1957). Development of rainbow trout brood stock by selective breeding. *Trans. Amer. Fish. Soc.* 85, 93-101.
- DORNESCO, G.T. & SANTA, V. (1963). La structure des aortes et des vaisseaux sanguins de la Carpe (Cyprinus carpio L.) *Anat. Anz.* 133, 136-145.
- EDDY F.B. (1971). Blood gas relationships in the rainbow trout, (Salmo gairneri). *J.exp.Biol.* 55, 695-711.
- FRANZ (1898). Über die Entwicklung von Hypochorda und Ligamentumlongitudinale ventrale bei Teleostiern. *Morph. Jahrb.* 25, 143-155.
- FRY, F.E.J. (1957). The aquatic respiration of fish. In *Physiology of Fishes*, vol. I. (ed. M.E. Brown) New York: Academic Press.



- GANNON, B.J. (1971) A study of the dual innervation of the teleost heart by a field stimulation technique. *Comp. Gen. Pharmacol.* 2, 175-183.
- GANNON, B.J. & BURNSTOCK, G. (1969) Excitatory adrenergic innervation of the fish heart. *Comp. Biochem. Physiol.* 29, 763-773.
- GANNON, B.J. & CAMPBELL G.D. (1972). Monoamine storage in relation to cardiac regulation in the Port Jackson shark Heterodontus portusjacksoni. *Z. Zellforsch.* 131, 437-450.
- GEGENBAUR, C. (1866) Zur vergleichenden anatomie der herzens. *Jena. Z. Naturw.* 2,
- GLASS, N.R. (1968). The effect of time of food consumption on the routine oxygen consumption of largemouth bass (Micropterus salmoides) *Ecology* 49, 340-343.
- GORKIEWICZ, G. (1947). Les vaisseaux sanguins des muscles du tronc de la truite (Salmo irideus Gibb) *Bull. int. Acad. pol. Sci. Lett.* 1947BII, 241-261.
- GRODZINSKI, Z. (1947). The main blood vessels of the brain in rainbow trout. *Bull.int.Acad.pol.Sci.Lett.* 1947BII 99-132.
- GRODZINSKI, Z. (1959). The development of the lymph heart in the sea trout. Salmo trutta. *Bull.Acad.Polanaise Sci. Ser.Sci.Biol.* 7, 305-311.
- GROVE, D.J., STARR, C.R., ALLARD, D.R. & DAVIES, W. (1972). Adrenaline storage in the pronephros of the plaice, Pleuronectes platessa L. *Comp.gen.Pharmac.* 3, 205-212.
- HABERICH F.J. (1965). The functional separation of venous and arterial blood in the univentricular frog heart. *Ann.N.Y.Acad.Sci.* 127, 459-476

- HART, I.C. (1967). Nomograms to calculate dissolved oxygen contents and exchange (mass transfer) coefficients. *Water Res.* 1, 391-395.
- HEATH, A.G. & PRITCHARD, A.W. (1962). Changes in the metabolic rate and blood lactic acid of bluegill sunfish, *Lepomis macrochirus*, Raf following severe muscular activity. *Physiol. Zool.*
- HOLETON, G.F. & RANDALL, D.J. (1967). The effect of hypoxia upon the partial pressure of gases in the blood and water afferent and efferent to the gills of rainbow trout. *J.exp.Biol.* 46, 317-327.
- HOLLIDAY, F.G.T., TYTLER, P. & YOUNG A.F. (1974). Activity of trout (*Salmo trutta*) in Airthrey Loch, Stirling and Loch Leven, Kinross. I.B.P. symposium on Loch Leven. Research (Stirling). *Proc.R.Soc.Edinb.* (in press).
- HYRTL (1843). cited by Kampmeier (1970).
- IRVING, L., BLACK, E.C. & SAFFORD, V. (1941). The influence of temperature upon the combination of oxygen with the blood of trout. *Biol. Bull.* 80, 1-17.
- JOHANSEN, K. (1962). Cardiac output and pulsatile aortic flow in the teleost *Gadus morhua*. *Comp. Biochem. Physiol.* 7, 169-174.
- JOHANSEN, K. (1965), Cardiovascular dynamics in fishes, amphibians and reptiles. *Ann.N.Y.Acad.Sci.* 127, 414-442.
- JOHANSEN, K. & HOL. R. (1964). Some functional aspects of ventricular structure in the lower vertebrate heart. cited by Johansen (1965).
- JOHANSEN, K. & MARTIN, A.W. (1965). Comparative aspects of cardiovascular function in vertebrates. In *Handbook of Physiology*, Section 2, Circulation, 3, 2583-2614. Ed. W.F. Hamilton. Washington D.C. : American Physiological Society.

- JULLIEN, A. & RIPPLINGER, J. (1957). Physiologie du coeur des poissons et son innervation extrinsèque. *Annls. scient. Univ. Besançon Zool. et Physiol.* 9, 35-92.
- KAMPMEIER, O.F. (1970). Evolution and comparative morphology of the lymphatic system. Springfield Illinois : Charles C. Thomas.
- KIRBY, S. & BURNSTOCK, G. (1969). Comparative pharmacological studies of isolated spiral strips of large arteries from the lower vertebrates. *Comp. Biochem. Physiol.* 28, 307-320.
- KONAIR, St. (1947). Le système des principaux vaisseaux sanguins du tube digestif de la truite (Salmo irideus) et de barbeau (Barbus fluviatilis).
- KOZIOL, St. (1947), Vascularization du labyrinthe de la truite arc en ceil (Salmo irideus Gibb). *Bull.int.Acad. pol.Sci.Lett.* 1947BII, 63-73.
- KUTTY, M.N. (1968), Respiratory quotients in goldfish and rainbow trout. *J.Fish.Res.Bd Can.* 25, 1689-1728.
- LABAT, R. (1966). Électrocardiologie chez les poissons Téléostéens: Influence de quelques facteurs écologiques. *Annales de Limnologie.* 2, 1-175. Faculté des Sciences de Toulouse. Station Biologique du Lac d'Orédon.
- LAFFONT, J. & LABAT, R. (1966). Action de l'adrenaline sur la fréquence cardiaque de la Carpe commune: Effet de la température du milieu sur l'intensité de la reaction. *J. Physiol. Paris.* 58, 351-355.
- LAURENT, P. (1962). Contribution à l'étude morphologique et physiologique de l'innervation de coeur des téléostéens. *Archs.Anat.microsc.Morph.exp.* 51, 337-458.

- LAURENT, P. (1967). Le pseudobranchie des Téléostéens: preuves electrophysiologique de ses fonctions, chémoreceptrice et baroreceptrice. C.R.Acad.Sci.Paris. 264, 1879-1882.
- LAURENT, P. & ROUZEAU, J.D. (1972). Afferent neural activity from pseudobranch of teleosts. Effects of PO<sub>2</sub>, pH, osmotic pressure and Na<sup>+</sup> ions. Respiration Physiology 14, 307-331.
- LUTZ, B.R. (1930). Reflex cardiac and respiratory inhibition in the Elasmobranch, Scylium canicula. Biol.Bull. 60, 170-178
- MAHONEY, R. (1966). Laboratory techniques in Zoology. London: Butterworths.
- MARSHALL HALL (1831). A critical and experimental essay on the circulation of the blood. London.
- McWILLIAM, J.A. (1885). On the structure and rhythm of the heart in fishes with especial reference to the heart of the eel. J.Physiol. 6, 192-245.
- MILLS, D. (1971). Salmon and trout: a resource, its ecology, conservation and management. Edinburgh: Oliver & Boyd.
- MILLS, T.W. (1886). The heart of fish compared with that of Menobranchus with special reference to reflex inhibition and independent cardiac rhythm. J.Physiol. 7, 81-95.
- MORGAN, R.I.G. (1973). Some aspects of metabolism in brown trout and perch. PhD Thesis University of Stirling.
- MORGAN, R.I.G. (1974). The energy requirements of trout and perch populations in Loch Leven, Kinross. I.B.P. Symposium on Loch Leven Research (Stirling). Proc.R.Soc. Edinb. (inpress).

- MOTT, J.C. (1950). Radiological observations on the cardiovascular system in Anguilla anguilla. J.exp. Biol. 27, 324-333.
- MOTT, J.C. (1951). Some factors affecting the blood circulation in the common eel (Anguilla anguilla). J. Physiol.Lond. 114, 387-398.
- MOTT, J.C. (1957). The cardiovascular system, In the Physiology of Fishes. Ed. M.E. Brown. 1, 81-108. New York: Academic Press.
- MUIR, B.S. & NIIMI A.J. (1972) Oxygen consumption of the euryhaline fish aholehole (Kuhlia sandvicensis) with reference to salinity, swimming, and food consumption. J.Fish.Res.Bd Can. 29, 67-77.
- NAKANO, T. & TOMLINSON, N. (1967). Catecholamine and carbohydrate concentrations in rainbow trout (Salmo gairdneri) in relation to physical disturbance. J.Fish.Res.Bd Can. 24, 1701-1715.
- NANDI, J. (1962). The structure of the interrenal gland in teleost fishes. Univ. Calif. Publs. Zool. 65, 129-212.
- NOMURA, S., IBARAKI, T., HIROSE, H. & SHIRAHATA, S. (1972) Application of back-pack cardiotelemeter for fishes. I. Heart rate and cardiac reflex in fishes during unrestrained swimming. Bull.Jap.Soc.scient.Fish. 38, 1105-1117.
- NORDEN, C.R. (1961). Comparative osteology of representative salmonid fishes with particular reference to the grayling (Thymallus arcticus) and its phylogeny. J.Fish.Res.Bd. Can. 18, 679-791.

- OECHMICHEN, E. (1958). Locomotion des Poissons. In  
Traité de Zoologie. (Ed. P. Grassé) 13 (1). Paris:  
Masson et Cie.
- OŠTÁDAL, B. & SCHIEBLER, T.H. (1971). Über die terminale  
strombahn in fischerzen. Z.Anat.Entwickl.-Gesch.  
134, 101-110.
- OWEN, R. (1866). On the anatomy of vertebrates. Vol. I  
Fishes and Reptiles. p468. London: Longmans, Green &  
Co.
- PARSONS, C.W. (1930). The conus arteriosus in fish.  
Q.J. Microscop.Sci. 73, 145-176.
- SMITH, L.S., BELL, G.R. (1964). A technique for prolonged  
blood sampling in free swimming salmon. J.Fish.Res.  
Bd.Can. 21, 711-717.
- RANDALL, D.J. (1966). The control of cardiac activity in the  
tench (Tinca tinca) and the goldfish (Carassius  
auratus). Physiol.Zool. 39, 185-192.
- RANDALL, D.J. (1970). The circulatory system. In Fish  
Physiology, (ed. W.S. Hoar & D.J. Randall) vol IV  
133-172. New York: Academic Press.
- RANDALL, D.J., HOLETON, G.F., & STEVENS, E.D. (1967).  
The exchange of oxygen and carbon dioxide across the  
gills of rainbow trout. J.exp.Biol. 46, 339-348.
- RANDALL, D.J. & SMITH, J.C. (1967). The regulation of  
cardiac activity in fish in a hypoxic environment.  
Physiol.Zool. 40, 104-113.
- RANDALL, D.J. & STEVENS, E.D. (1967). The role of adrenergic  
receptors in cardiovascular changes associated with  
exercise in salmon. Comp. Biochem. Physiol. 21, 415-424.

- RANKIN, J.C. & MAETZ, J. (1971). A perfused teleostean gill preparation : Vascular actions of neurohypophysial hormones and catecholamines. *J. Endocrinol.* 51, 621-635.
- RAO, R.M.M. (1968). Oxygen consumption of rainbow trout (*Salmo gairdneri*) in relation to activity and salinity. *Can.J.Zool.* 46, 781-786.
- RICHARDS, F.B. & FROMM, P.O. (1969). Patterns of blood flow through filaments and lamellae of isolated-perfused rainbow trout (*Salmo gairdneri*) gill. *Comp. Biochem. Physiol.* 29, 1063-1070.
- RICKLEFS, R.E. (1967). A graphical method of fitting equations to growth curves. *Ecology* 48, 978-983.
- ROBIN, M.C. (1880), Note sur quelques caractères et sur le couer caudal des anguilles des congres et des leptocéphales. *J.Anat. Physiol. Paris.* 16, 593-628.
- SAITO, T. (1973), Effects of vagal stimulation on the pacemaker action potentials of carp heart. *Comp. Biochem. Physiol.* 44A, 191-199.
- SANTER, R.M. (1972). Ultrastructural and histochemical studies on the innervation of a heart of a teleost. *Pleuronectes platessa* L. *Z.Zellforsch.* 131, 519-528.
- SANTER, R.M. & COBB, J.L.S. (1972). The fine structure of the heart of the teleost. *Plexuronectes platessa* L. *Z. Zellforsch.* 131, 1-14.
- SATCHELL, G.H. (1971). *Circulation in Fishes.* Cambridge Monographs in Experimental Biology No. 18: Cambridge University Press.

- SAUNDERS, R.L. & SUTTERLIN, A.M. (1971). Cardiac and respiratory response to hypoxia in the sea raven, Hemipterus americanus, and an investigation of possible control mechanisms. J.Fish.Res.Bd. Can. 28, 491-503.
- SIKORAWA, L. (1947). The bordering region of the head and trunk of Salmo irideus Gibb. (with special references on its vascular system). Bull.int. Acad.Pol.Sci. Lett. 1947BII 299-308.
- SMITH, L.S. & BELL, G.R. (1964). A technique for prolonged blood sampling in free swimming salmon. J.Fish.Res. Bd. Can. 21, 711-717.
- STEVENS, E.D. (1968). The effect of exercise on the distribution of blood to various organs in rainbow trout. Comp. Biochem. Physiol. 25. 615-625.
- STEVENS, E.D., BENNION, G.R., RANDALL, D.J. & SHELTON, G. (1972). Factors affecting arterial pressures and blood flow from the heart in intact unrestrained Lingcod, Ophiodon elongatus. Comp. Biochem. Physiol. 43A, 681-695.
- STEVENS, E.D. & RANDALL, D.J. (1967a). Changes in blood pressure, heart rate and breathing rate during moderate swimming activity in rainbow trout. J.exp.Biol. 46, 307-315.
- STEVENS, E.D. & RANDALL, D.J. (1967b). Changes in gas concentrations in blood and water during moderate swimming activity in rainbow trout. J.exp.Biol. 46, 329-337.



- STREETER, D.D., SPOTNITZ, H.M., PATEL, D.P., ROSS, J. & SONNENBLICK, E.H. (1969). Fiber orientation in the canine left ventricle during diastole and systole. *Circ. Res.* 24, 339-347.
- SUTTERLIN, A.M. (1969). Effects of exercise on cardiac and ventilation frequency in three species of freshwater fish. *Physiol. Zool.* 42, 36-52.
- TALBOT, S.A. & GESSNER, U. (1973). *Systems physiology*. New York: Wiley.
- TAYLOR, W., HOUSTON, A.H. & HORGAN, J.D. (1968). Development of a computer model simulating some aspects of the cardiovascular respiratory dynamics of the salmonid fish. *J.Exp.Biol.* 49, 477-493.
- TYTLER, P. (1968). Relationship between oxygen consumption and swimming speed in the Haddock. (Melanogrammus aeglefinus.) *Nature, Lond.* 221, 274.
- VON SKRAMLICK, E. (1935). Über der Kreislauf bei den Fischen. *Ergebn. Biol.* 11, 1-130.
- WARDLE, C.S. (1971). New observations on the lymph system of the plaice Pleuronectes platessa and other teleosts. *J.Mar.Biol.Ass. U.K.* 51, 977-990.
- WARDLE, C.S. (1972). The changes in blood glucose in Pleuronectes platessa following capture from the wild; a stress reaction. *J.Mar.Biol.Ass.U.K.* 52, 635-653.
- WEBB, P.W. (1970). Some aspects of the energetics of swimming of fish with special reference to the cruising performance of rainbow trout. Ph.D. thesis, University of Bristol.
- WEBB, P.W. (1971a). The swimming energetics of trout. I. Thrust and power output at cruising speeds. *J.exp.Biol.* 55, 489-520.

- WEBB, P.W. (1971b). The swimming energetics of trout. II. Oxygen consumption and swimming efficiency. *J.exp.Biol.* 55, 521-540.
- WOOD, C.M. & RANDALL, D.J. (1973a). The influence of swimming activity on sodium balance in the rainbow trout (*Salmo gairdneri*). *J.comp. Physiol.* 82, 207-233.
- WOOD, C.M. & RANDALL, D.J. (1973b). Sodium balance in the rainbow trout (*Salmo gairdneri*) during extended exercise. *J. comp. Physiol.* 82, 235-256.
- WOOD, C.M. & RANDALL D.J. (1973c). The influence of swimming activity on water balance in the rainbow trout (*Salmo gairdneri*). *J.comp. Physiol.* 82, 257-276.
- YAMAUCHI, A. & BURNSTOCK, G. (1968). An electron microscope study on the innervation of the trout heart. *J.Comp. Neurol.* 132 567-588.

APPENDIX I

RESULTS OF SWIMMING TRIALS

6.5°C INTACT FISH

Fish Ref. No.	Length cm	Trial Ref. No.	Speed		Heart rate		50% recovery time mins.
			cm/sec	(V/L)	mean	S.D.	
2	27.0	I	41.8	1.55	56.08	4.26	6.8
		IVa	5.0	0.2	39.03	2.01	-
		IV	16.2	0.6	39.63	2.73	0.0
		IVb	5.0	0.1	37.46	1.53	-
		Va	5.0	0.2	34.63	1.35	-
		V	25.65	0.95	40.13	3.83	1.0
		VIa	5.0	0.2	31.83	0.77	-
		VI	32.4	1.2	48.63	3.57	2.2
		VIIa	5.0	0.2	33.40	1.10	-
		VII	36.45	1.35	60.44	2.64	4.2
		VIIIa	5.0	0.2	31.66	1.80	-
VIII	28.4	1.05	47.40	6.00	0.5		
IXa	5.0	0.2	30.40	1.13	-		
IX	22.95	0.85	37.00	2.86	0.6		
Xa	5.0	0.2	26.57	0.93	-		
X	17.55	0.65	33.28	2.09	0.6		
XIa	5.0	0.2	31.90	1.52	-		
XI	41.8	1.55	54.46	3.96	17.0		
3	24.5	Ia	5.0	0.2	27.18	1.74	-
		I	25.2	1.15	51.37	1.30	5.4
		IIa	5.0	0.2	25.13	1.80	-
		II	20.8	0.85	37.31	1.95	1.5
6	24.5	Ia	5.0	0.2	34.37		-
		I	26.2	1.07	41.26	1.06	0.4
		IIa	5.0	0.2	37.45		-
		II	29.8	1.21	44.74	2.75	1.0
		IIIa	5.0	0.2	31.64		-
		III	33.8	1.38	56.29	1.96	3.5
		IVa	5.0	0.2	31.95		-
		IV	19.6	0.79	34.74	3.18	-
		V	14.0	0.57	31.04	3.62	0.0
		VIIa	5.0	0.2	33.70		-
VII	40.1	1.66	55.26	1.89	8.1		
VI	34.4	1.4	56.20	2.27	-		
7	24.1	IIa	5.0	0.2	34.86	0.37	-
		II	25.0	1.04	47.31	1.35	0.3
		III	32.0	1.33	53.24	2.17	0.8
		IV	34.3	1.42	56.04	1.37	5.5

6.5°C UNILATERALLY VAGOTOMISED FISH

9	24.2	Ia	5.0	0.2	32.47	1.31	-
		I	28.0	1.16	56.26	1.72	3.3
		IIa	5.0	0.2	35.47	2.54	-
		II	18.6	0.77	36.41	1.57	0.2
		IIIa	5.0	0.2	35.75	1.38	-
III	38.4	1.59	56.81	0.85	7.1		
IV	35.2	1.45	54.11	2.45	0.2		

PL

## 6.5°C-BILATERALLY VAGOTOMISED FISH

Fish Ref. No.	Length cm	Trial Ref. No.	Speed		Heart rate		50% recovery time mins.
			cm/sec	(V/L)	mean	S.D.	
8	25.1	IIa	5.0	0.2	56.85	0.80	-
		II	16.57	0.77	56.74	0.66	-
		IIIa	5.0	0.2	53.62	0.44	-
		III	31.9	1.27	59.07	1.11	-
		IV	23.85	0.95	58.64	1.38	-
		IVa	5.0	0.2	55.07	0.26	-
		Va	<5.0	0.15	50.60	1.59	-
		V	16.2	0.64	49.54	0.64	-
		VIa	5.0	0.15	55.17	1.64	-
		VI	24.4	0.97	54.17	0.94	-
		VIIa	<5.0	0.15	43.45	0.56	-
		VII	13.05	0.52	46.08	1.14	-
		VIIIa	<5.0	0.15	48.06	3.89	-
		VIII	28.1	1.12	55.65	2.87	-
10	25.5	IXa	<5.0	0.15	43.17	2.41	-
		IX	22.1	0.80	47.70	1.14	-
		Xa	<5.0	0.15	40.67	2.35	-
		X	31.9	1.27	56.89	1.91	-
		Ia	5.0	0.2	49.56	0.96	-
		I	21.65	0.85	54.35	0.57	-
		IIa	5.0	0.2	48.00	0.57	-
		II	24.4	0.96	52.27	0.87	-
		IIIa	<5.0	0.15	47.77	0.67	-
		III	13.9	0.54	52.00	0.87	-
IVa	<5.0	0.15	49.63	0.72	-		
IV	30.4	1.19	51.96	0.54	-		
Va	<5.0	0.15	46.53	0.57	-		
V	34.1	1.34	48.91	0.99	-		
VIa	<5.0	0.15	48.88	0.66	-		
VI	15.3	0.60	51.46	0.57	-		
VIIa	<5.0	0.15	47.00	1.01	-		
VII	35.6	1.39	52.41	0.93	-		
VIIIa	<5.0	0.15	46.66	0.66	-		
VIII	12.5	0.49	49.41	1.01	-		
IXa	<5.0	0.15	43.91	0.69	-		
IX	22.6	0.89	48.67	0.68	-		
Xa	<5.0	0.15	42.23	0.73	-		
X	36.4	1.47	51.43	0.84	-		

## 15°C INTACT FISH

11	28.2	Ia	5.0	0.2	55.17	2.28	-
		I	37.6	1.34	58.72	4.27	0.0
		IIa	5.0	0.2	47.75	1.61	-
		II	45.9	1.63	70.08	7.18	0.8
13	27.8	Ia	5.0	0.2	52.07	1.56	-
		I	35.3	1.1	63.08	3.81	0.0
		IIa	5.0	0.2	48.85	1.57	-
		II	41.3	1.49	64.11	2.93	-
		III	49.5	1.78	79.75	3.62	9.9
14	24.5	IV	61.6	2.22	94.44	1.45	4.0
		I	41.3	1.69	84.33	2.51	0.4
		II	45.2	1.84	94.67	3.33	-
		III	46.5	1.90	98.22	2.82	26.0

15°C-INTACT FISH (cont.)

Fish Ref. No.	Length cm	Trial Ref. No.	Speed		Heart rate		50% recovery time mins.
			cm/sec	(V/L)	mean	S.D.	
18	26.0	I	52.5	2.02	90.31	3.24	25.0
		IIIa	5.0	0.2	43.77	1.63	-
		III	16.0	0.62	47.41	1.42	2.5
		Va	5.0	0.2	41.14	1.39	-
		V	51.0	1.96	93.06	2.17	93.0
		IVa	5.0	0.2	49.12	2.56	-
		VI	29.7	1.14	70.71	1.97	0.5
		VIIa	5.0	0.2	43.35	2.35	-
		VII	21.8	0.84	51.64	4.32	0.0
VIII	24.4	0.94	55.40	3.0	0.0		
21	25.5	Ia	5.0	0.2	44.72	1.38	-
		I	21.0	0.82	64.67	4.08	-
26	27.5	IIIa	5.0	0.2	39.00	0.93	-
		III	28.5	1.04	46.19	1.74	0.5
		IVa	5.0	0.2	43.95	1.81	-
		IV	54.3	1.97	91.19	2.59	11.5
		IVb	5.0	0.2	31.75	-	-
		VIa	5.0	0.2	51.06	1.39	-
		VI	54.9	1.99	93.81	4.3	-

15°C UNILATERALLY VAGOTOMISED FISH

16	27.0	Ia	5.0	0.2	38.3	1.89	-
		I	22.2	0.82	52.48	3.40	2.4
		IIa	5.0	0.2	37.93	2.15	-
		II	33.9	1.25	68.58	2.99	1.0
		IIIa	5.0	0.2	33.06	1.57	-
		III	41.3	1.53	73.36	8.14	3.0
		IVa	5.0	0.2	31.00	1.45	-
		IV	53.9	2.0	95.31	3.21	27.0
		Va	5.0	0.2	39.38	2.82	-
		V	42.1	1.56	72.72	2.65	1.1
		VIa	5.0	0.2	39.67	5.08	-
		VI	57.8	2.14	97.46	2.24	30.0
		VIIa	5.0	0.2	40.50	0.80	-
		VII	18.6	0.69	42.56	2.08	0.0
		VIIIa	5.0	0.2	38.27	1.44	-
VIII	59.3	2.2	95.72	2.51	47.0		

15°C BILATERALLY VAGOTOMISED FISH

22	25.7	I	38.3	1.52	82.00	2.13	0.0
		IIa	5.0	0.2	53.57	2.62	-
		IIIa	5.0	0.2	61.83	1.40	-
		IVa	5.0	0.2	52.59	1.53	-
		Va	5.0	0.2	52.53	2.62	-
		VII	17.0	0.66	55.48	2.46	0.0
		VIIIa	5.0	0.2	59.56	1.13	-
		VIII	24.6	0.96	63.00	6.16	0.0
		24	25.7	Ia	5.0	0.2	34.63
I	24.25			0.94	47.46	3.40	1.0
IIa	5.0			0.2	35.85	1.23	-
II	34.8			1.35	74.56	2.77	1.6

15°C BILATERALLY VAGOTOMISED FISH (cont.)

Fish Ref. No.	Length cm	Trial Ref. No.	Speed		Heart rate		50% recovery time mins.
			cm/sec	(V/L)	mean	S.D.	
24	25.7	IIIa	5.0	0.2	30.54	1.06	-
		III	38.0	1.48	72.70	7.60	5.0
		IVa	5.0	0.2	34.45	1.18	-
		IV	47.5	1.85	79.10	3.78	1.7
		Va	5.0	0.2	30.61	1.17	-
		V	50.7	1.97	79.45	2.40	2.1
		VIa	5.0	0.2	32.16	1.03	-
		VI	57.1	2.22	82.87	2.38	38.0
		VIIa	5.0	0.2	42.07	4.84	-
		VII	24.5	0.95	51.33	6.88	0.2
		VIIIa	5.0	0.2	35.92	1.26	-
		IXa	5.0	0.2	37.17	1.56	-
		IX	32.0	1.25	61.69	1.64	1.2
		Xa	5.0	0.2	39.46	2.15	-
		X	34.8	1.35	73.15	3.89	1.2
		XIa	5.0	0.2	37.39	1.58	-
XI	55.0	2.14	82.48	2.21	12.3		
25	27.0	I	37.2	1.38	78.57	2.66	1.0
		IIa	5.0	0.2	60.03	1.33	-
		II	43.4	1.61	85.58	1.81	2.6
		IIIa	5.0	0.2	51.59	2.74	-
		IVa	5.0	0.2	56.08	1.61	-
		Va	5.0	0.2	59.25	1.25	-

N.B. Trial reference numbers with suffixes a or b refer to periods of 'rest' in a flow of 5.0cm/sec or less. The error in these low speed estimates is  $\pm 1$ cm/sec. Because of this, and due to uncertainties in the precise fish activity level (see discussion) an approximate specific speed of 0.2 or 0.15(V/L) is given. These speed values are not used in any further calculations.

APPENDIX II

RESULTS OF RESPIROMETER EXPERIMENTS - OXYGEN CONSUMPTION & HEART RATES

Fish Ref. No.	Length cm	Weight g	Trial Ref. No.	Heart rate mean	S.D.	O <sub>2</sub> consumption mg/kg/hr
29	25.0	211.3	1	79.96	3.51	295.2
			3	85.10	4.51	341.8
			4	75.30	1.64	124.3
			5	73.95	2.44	147.6
			6	81.30	5.26	349.6
			7	75.73	2.05	144.5
			8	73.41	1.33	132.1
			30	26.2	212.6	2
31	25.6	212.2	1	81.70	4.03	255.3
			2	78.50	1.97	201.2
			3	77.17	2.90	154.7
			4	59.00	6.22	154.7
			5	60.00	5.54	170.2
			6	56.59	1.74	147.0
			7	58.73	6.80	216.6
			8	91.96	1.64	417.7
			9	109.20	3.72	402.3
			10	99.17	2.86	410.0
32	26.3	225.1	1	55.22	8.31	189.6
			2	47.00	2.94	145.9
			3	46.86	5.31	116.7
			4	42.04	4.37	102.1
			5	39.86	1.96	87.5
			6	40.00	1.38	116.7
			7	38.06	1.91	109.4
			8	37.82	2.24	65.7
			9	42.30	3.47	87.5
			10	44.39	2.76	131.3
			11	48.39	2.67	138.6
			12	62.83	7.62	277.1
33	26.5	237.8	2	69.77	2.00	158.8
			3	71.18	1.50	165.7
			4	70.61	3.35	131.2
			5	78.71	1.63	151.9
			6	63.37	3.00	289.9
			7	76.61	2.10	214.0
			8	79.17	2.69	289.9
			9	84.00	3.92	379.7
			10	85.59	4.29	338.3
			34	26.8	242.7	1
2	61.87	3.12				128.5
3	61.52	4.22				88.0
4	54.26	2.26				94.0
5	50.25	2.86				122.1
6	50.18	2.30				94.0
7	58.30	1.79				115.0
8	50.29	1.40				108.3

APPENDIX III

Some of the work described in this thesis has been reported  
in the following article:-

PRIEDE, I.G.(1973). The effect of swimming activity and  
section of the vagus nerves on heart rate in Rainbow  
trout. J.exp.Biol. (in press)



Attention is drawn to the fact that the copyright of this thesis rests with its author.

This copy of the thesis has been supplied on condition that anyone who consults it is understood to recognise that its copyright rests with its author and that no quotation from the thesis and no information derived from it may be published without the author's prior written consent.