

A Host-Host-Pathogen Model with Vaccination and its Application to Target and Reservoir Hosts.

Rachel Norman¹ and Roger G Bowers²

1. Department of Computing Science and Mathematics
University of Stirling
Stirling
FK9 4LA
2. Department of Mathematical Sciences
University of Liverpool
Maths and Oceanography Building
Liverpool
L69 3BX

Corresponding Author: Rachel Norman
Department of Computing Science and Mathematics
University of Stirling
Stirling
FK9 4LA
Telephone: +44 01786 467466
Fax +44 1786 464551
email: rachel.norman@cs.stir.ac.uk

Short title: Vaccination in two-host systems.

A Host-Host-Pathogen Model with Vaccination and its Application to Target and Reservoir Hosts.

Abstract

In this paper we present a simple theoretical framework which allows us to study the impact of constant vaccination rates in a system in which two species interact through a shared pathogen. We look at this firstly in purely theoretical terms to determine which equilibria will be stable for which parameter combinations. We then consider two special cases and determine the long term population dynamical consequences of differing vaccination strategies. In particular we describe systems for which there is a wildlife host reservoir and a domestic (target) host. We find that when the target host cannot maintain the disease alone, and the presence of the reservoir causes the target host to be eradicated by the disease, vaccinating the target species allows coexistence of the two species with the pathogen, but will not allow disease eradication. It is then shown that this result holds both when vaccination occurs at a fixed rate and when a proportion of the population is vaccinated at birth.

Keywords: vaccination; target; reservoir; disease: mathematical model;

1. Introduction

Mathematical models have been used extensively to study the effects of vaccination on the dynamics of an infection within a host population. Initially, this work has concentrated on human disease due to both the public health implications of such studies and the data available in this area. Recently, however, similar modelling techniques have been applied to the vaccination of both domestic and wild animals. This is particularly important in the context of emerging diseases of domestic hosts or humans, which often have a known or suspected wildlife reservoir. It has been shown recently that 62% of all human pathogens also infect animals and 77% of livestock pathogens and 91% of domestic carnivore pathogens infect multiple hosts (Cleaveland et al 2001). Examples include tick borne encephalitis in humans and rodents, rabies in dogs and foxes (Europe) or in wild dogs (Africa) and bovine tuberculosis in cattle and badgers.

However just because two hosts can both be infected by a pathogen does not necessarily mean that there is transmission between these species. There has been recent discussion about the identification of reservoirs of infection (Haydon et al 2002). In this paper we will only consider pathogens that can be transmitted between species. Indeed the model we will present here assumes that the only contact between the species is via infection i.e. the species are not in competition for resources. In order to control the disease in this case, we will determine which species should be the aim of our control strategy or whether we need to treat both species. In this paper we will only consider control through vaccination.

Whilst previous models have studied the effect of vaccinating one species, there have been few studies of host- host pathogen models which include vaccination (except see Kribs-Zaleta and Velasco-Hernandez 2000). However, host-host pathogen models have been used to study other aspects of species interactions (e.g. Holt and Pickering 1985, Begon and Bowers 1994 Bowers and Turner 1997). The aim of this paper is to build a theoretical framework that will allow us to study the impact of vaccination, at a fixed rate, on a system in which two species interact through a shared pathogen where the transmission is density dependent. We will then go on to look at two case studies in

which one host is the target, i.e. the host in which we wish to control the disease and the other host is a reservoir for the disease. In this case our definitions of target and reservoir are as taken from Haydon et al 2002. Finally, we will consider vaccinating a proportion of one of the species at birth and use a technique developed by Roberts and Heesterbeek (2003) to determine the threshold level of vaccination required to control the disease.

2. The model and results:

In this case we are considering two hosts which have density dependent growth rates and a disease which is directly transmitted. The model is represented in a flow diagram in figure 1 and described by the following equations:

$$\frac{dY_i}{dt} = \beta_{ii} X_i Y_i + \beta_{ij} X_i Y_j - \Gamma_i Y_i \quad (1)$$

$$\frac{dZ_i}{dt} = \mu_i Y_i + \nu_i X_i - b_i Z_i - \gamma_i Z_i \quad (2)$$

$$\frac{dH_i}{dt} = r_i H_i \left(1 - \frac{H_i}{K_i} \right) - \alpha_i Y_i \quad (3)$$

$$i, j = 1, 2 \quad \Gamma_i = \alpha_i + b_i + \mu_i \quad r_i = a_i - b_i$$

Here H_i is the total host population density for species i , and Y_i and Z_i are the densities of infected and immune hosts of species i respectively. The density of susceptible hosts of species i is given by $X_i = H_i - Y_i - Z_i$. It should be noted that transmission of the disease is assumed to be density dependent. The reason for this is twofold, firstly this is consistent with other two host models that have been analysed (eg. Begon and Bowers 1995) and secondly it is likely to be biologically realistic for wildlife disease systems where contact saturation has probably not occurred. The vaccination rate of species i is given by ν_i and the other parameters are defined in Table 1. This is a simple method of including vaccination which does not allow for vaccine efficacy or waning- except implicitly in the loss of immunity - which have been shown to have a potentially disruptive effect on vaccination programmes (e.g Arino et al 2004). However this is a baseline model which will give us results on which to build more complex vaccine mechanisms later (see discussion).

Asymptotic analysis of this model shows that there are 7 possible equilibria labelled $(Y_1, Z_1, H_1, Y_2, Z_2, H_2)$ in this case (although we have no proof that the last is unique- see discussion below). See appendix A for the full details of the analysis.

There are three trivial equilibria, one where no individuals of either species are present ($E1=(0,0,0,0,0,0)$) and two where either species is alone and uninfected at its carrying capacity ($E2=\left(0, \frac{v_1 K_1}{v_1 + b_1 + \gamma_1}, K_1, 0, 0, 0\right)$ and $E3=\left(0, 0, 0, 0, \frac{v_2 K_2}{v_2 + b_2 + \gamma_2}, K_2\right)$). These are never stable unless one, or both, of the species has negative growth rate, $r_i < 0$, i.e., they have disease free death rates that are higher than their birth rates ($b_i > a_i$) and we shall ignore this possibility. In other words we assume that all populations are viable in the absence of the disease (see Appendix A for all of the mathematical detail underlying our arguments.)

The equilibrium where both species are present at their carrying capacities ($E4=\left(0, \frac{v_1 K_1}{v_1 + b_1 + \gamma_1}, K_1, 0, \frac{v_2 K_2}{v_2 + b_2 + \gamma_2}, K_2\right)$) is stable if and only if $r_i > 0$ and $R_i < 1$ for $i=1$ and 2 , where $R_i = \frac{\beta_{ii} K_i (b_i + \gamma_i)}{\Gamma_i (b_i + v_i + \gamma_i)}$, and

$$(1 - R_1)(1 - R_2) > R_{12} R_{21} \quad (4)$$

$$\text{Where } R_{ij} = \frac{\beta_{ij} K_i (b_i + \gamma_i)}{\Gamma_j (b_i + v_i + \gamma_i)}.$$

Here, R_i is one of two effective reproduction numbers, it is made up of two factors, the basic reproductive number of the infection within species i multiplied by the factor by which vaccination reduces the reproduction number. The cross species reproduction number is given by R_{ij} and is made up of two similar factors. The first is the number of new infections that would occur if we added on infected individual of species j

into a totally susceptible population of species i $\left(\frac{\beta_{ij}K_i}{\Gamma_2}\right)$. This is then multiplied by the factor by which vaccination reduces the reproductive rate.

Therefore $R_i < 1$ is the condition for the disease to die out if species i was alone with the disease. The presence of two species together gives us the second, more complicated condition for the disease to die out. For both of these inequalities their biological interpretation is that there are not enough individuals present in the population for the disease to persist, either for each species alone, or both for species in combination.

The equilibrium where species 1 is present alone with the disease ($E5=(Y_1^*, Z_1^*, H_1^*, 0, 0, 0)$) is biologically relevant and stable if

$$r_1 > 0, R_1 > 1, r_2 < \frac{\alpha_2 \beta_{21} Y_1^*}{\beta_{21} Y_1^* M_2 + \Gamma_2 \phi_2} \quad \text{and} \quad A_1 B_1 > C_1 \quad (5)$$

Where, $A_1 = \beta_{21} Y_1^* + \Gamma_2 - r_2 + \nu_2 + b_2 + \gamma_2$,

$$B_1 = \beta_{21} Y_1^* (\mu_2 + b_2 + \gamma_2 + \alpha_2 - r_2) + (\Gamma_2 - r_2)(\nu_2 + b_2 + \gamma_2) - r_2 \Gamma_2,$$

$$C_1 = (b_2 + \gamma_2)(\beta_{21} Y_1^* (\alpha_2 - r_2 M_2) - \Gamma_2 r_2 \phi_2), \quad Y_1^* = \frac{1}{M_1} \left(H_1^* - \frac{K_1}{R_1} \right), \quad \phi_1 = \frac{b_1 + \nu_1 + \gamma_1}{b_1 + \gamma_1},$$

$$M_1 = \frac{b_1 + \gamma_1 + \mu_1}{b_1 + \gamma_1} \quad \text{and} \quad H_1^* = \frac{K_1}{2} \left(1 - \varepsilon_1 + \sqrt{(\varepsilon_1 - 1)^2 + 4 \frac{\varepsilon_1}{R_1}} \right) \quad \text{with} \quad \varepsilon_1 = \frac{\alpha_1}{r_1 M_1}.$$

(with similar definitions for species 2). Biologically these four conditions have different interpretations. The first two conditions mean, as discussed earlier, that population 1 must be able to persist in the absence of the disease and that the disease must be able to persist in species one in the absence of species 2 respectively. If the final condition ($A_1 B_1 > C_1$) is not satisfied then we have stable limit cycles about this equilibrium rather than a stable equilibrium. The third condition is more difficult to interpret biologically but represents the interaction between the two species. Effectively it says that if the transmission from species 1 to species 2 is high then it can overpower the growth rate of species 2 and cause it to die out.

If we replace 1s with 2s and vice versa we get the conditions for stability of the equilibrium with species 2 alone with the disease (E6).

If the conditions described above hold for both species 1 and species 2 simultaneously then both equilibria where one species is present alone with the pathogen (E5 and E6) are stable and the long term outcome is determined by the initial conditions (contingency).

When we consider the existence and stability of the infected coexistence equilibrium (E7) when the disease is endemic in both species, it should be noted that, with appropriate modifications, the results presented here are entirely consistent with that of the model without immunity or vaccination presented by Greenman and Hudson (2000). In that paper they have shown that it is possible under some parameter regimes to have more than one biologically relevant coexistence equilibrium, and even more than one stable coexistence equilibrium. In which case the initial conditions determine which equilibrium is stable. Whilst the existence of these complexities is interesting, we shall ignore the detail of them for the purposes of this paper since it turns out that they are not relevant in the context of our (numerical) examples. We therefore make the simplifying assumption that when none of the other equilibria are stable then either the equilibrium with both species coexisting with the disease is stable or we have stable limit cycles in the area of parameter space in which we are interested.

These results are summarised in terms of the different regions of parameter space in table 2.

We can represent all of the inequalities described in table 2- or rather the corresponding equalities- by curves in parameter space and we are interested in how they relate to one another and how they are affected by changes in the parameters, in particular the vaccination parameters. We will study these curves from two different points of view, that is, in K_1 - K_2 space and in $\nu_1 - \nu_2$ space. In each case we keep the values of all other parameters fixed.

K_1 - K_2 space:

If we define $R_i = \frac{\beta_{ii}K_i(b_i + \gamma_i)}{\Gamma_i(b_i + \nu_i + \gamma_i)}$ then the boundary curves can be seen in figure 2.

The shape of the boundary to uninfected coexistence can be either concave or convex but always passes through the points where $R_i = 1$ i.e. $\left(\frac{\Gamma_1(b_1 + \nu_1 + \gamma_1)}{b_1 + \gamma_1}, 0\right)$ and

$\left(0, \frac{\Gamma_2(b_2 + \nu_2 + \gamma_2)}{b_2 + \gamma_2}\right)$. Clearly other choices of parameter value would mean that the lines

which separate species i alone with the disease from infected coexistence need not appear on the diagram at all, since they can be negative (they can also be very large). However, they are always straight lines with equations

$$K_i = S_i = \frac{\beta_{ii}B_i^2}{\varepsilon_i\Gamma_i\phi_i - B_i\beta_{ii}(\varepsilon_i - 1)} \quad (6)$$

where $B_i = \frac{M_i r_j \Gamma_j (v_j + b_j + \gamma_j)}{\beta_{ji}(\alpha_j(b_j + \gamma_j) - r_j(b_j + \gamma_j + \mu_j))} + \frac{\Gamma_i \phi_i}{\beta_{ii}}$ is constant with respect to K_i

and the other parameters are defined above or in table 1. These equations come from

setting $r_2 = \frac{\alpha_2 \beta_{21} Y_1^*}{\beta_{21} Y_1^* M_2 + \Gamma_2 \phi_2}$, substituting in for Y_1^* and subsequently H_1^* and then

rearranging in terms of K_1 .

Effect of vaccination:

If we wish to consider the effects of vaccination on these boundaries then we see that as we change ν_i they will move; however their shape will not change. If we firstly look at the $R_i = 1$ boundaries we see that they increase with increasing ν_i and do not depend on ν_j ; therefore increasing the level of vaccination increases the region in which uninfected coexistence occurs. However, the effect of vaccination on the S_i lines is not so straightforward. In fact it is possible to either increase or decrease S_i whilst increasing either ν_i or ν_j . This depends on the relative sizes of the other parameter values.

It is therefore sensible to redraw these curves using different axes which allow the direct study of vaccination. We consider all other parameter values to be fixed, including the K_i s, and see what these boundaries look like in $v_1 - v_2$ space.

$v_1 - v_2$ **space.**

In this case, the curves are more complicated because they change according to what happens when there is no vaccination, i.e., at the origin.

The simplest lines to draw are those which are equivalent to the threshold host density lines ($R_i = 1$). These can be rewritten in terms of a threshold vaccination rate (v_{iT}) given by

$$v_{iT} = (b_i + \gamma_i) \left(\frac{\beta_{ii} K_i}{\Gamma_i} - 1 \right) \quad (7)$$

There are five possible scenarios

1. Uninfected coexistence (E4) at the origin.

Here $R_1 < 1$, $R_2 < 1$ and $(1 - R_1)(1 - R_2) > R_{12}R_{21}$.

This is the trivial example. In this case the disease would not persist in the absence of vaccination and so vaccinating has no effect.

2. Infected coexistence (E7) at the origin

Here $R_1 > 1$, $R_2 > 1$, $r_2 > \frac{\alpha_2 \beta_{21} Y_1^*}{\beta_{21} Y_1^* M_2 + \Gamma_2 \phi_2}$, $r_1 > \frac{\alpha_1 \beta_{12} Y_2^*}{\beta_{12} Y_2^* M_1 + \Gamma_1 \phi_1}$ and $(1 - R_1)(1 - R_2) < R_{12}R_{21}$.

If we have infected coexistence at the origin then the boundaries are given in figure 3. We can see that this is a simple picture. The only possible types of long term behaviour are infected or uninfected coexistence separated by a hyperbola in $v_1 - v_2$ space. This curve always has negative gradient. The only possible effect of vaccinating or increasing vaccination rates is to cause the pathogen to die out in a system in which, without vaccination, the disease would have persisted in the presence of both hosts. In the case of figure 3 the shape of the curve implies that we would have to vaccinate both

species in order to eradicate the disease. However it would be possible to choose parameters for which the threshold in v_i is zero (or negative) and so we would only have to vaccinate one species in order to eradicate the disease (see Figure 4).

3. Species 1 alone with the pathogen (E5) at the origin

$$\text{Here } R_1 > 1 \text{ and } r_2 < \frac{\alpha_2 \beta_{21} Y_1^*}{\beta_{21} Y_1^* M_2 + \Gamma_2 \phi_2}$$

If we have species 1 alone with the pathogen at the origin then the boundaries are shown in figure 5. In this case we can see that the shapes of the curve are more complicated. At the origin there is apparent competition between the two species mediated by the pathogen and species 2 is eradicated due to the disease being maintained in species 1. In this case vaccination of either species can cause the two species to coexist with the disease. If we vaccinate species 2, this protects the species directly and allows the population of species 2 to persist. If however we vaccinate species 1, we will be lowering the incidence of the disease in species 1 and will eventually reduce it to a level which is tolerable to species 2. Infected coexistence could be reached by vaccinating either species alone or by vaccinating both species. It is possible in this case that infected coexistence is a sufficiently good outcome and we simply wish to use vaccination to help species 2 re-establish itself (or invade). However, if we wish to eradicate the disease and allow both species to persist at their carrying capacities we must vaccinate both species in order to get the populations into the uninfected coexistence regions.

4. Species 2 alone with the pathogen (E6) at the origin

$$\text{Here } R_2 > 1 \text{ and } r_1 < \frac{\alpha_1 \beta_{12} Y_2^*}{\beta_{12} Y_2^* M_1 + \Gamma_1 \phi_1}$$

If we have species 2 alone with the pathogen at the origin then the boundaries are shown in figure 6. In this case the dynamics parallel those discussed above.

5. Contingency at the origin

$$\text{Here } R_1 > 1, r_2 < \frac{\alpha_2 \beta_{21} Y_1^*}{\beta_{21} Y_1^* M_2 + \Gamma_2 \phi_2}, R_2 > 1 \text{ and } r_1 < \frac{\alpha_1 \beta_{12} Y_2^*}{\beta_{12} Y_2^* M_1 + \Gamma_1 \phi_1}.$$

If we have contingency at the origin then the boundaries are shown in figures 7a and 7b. In this case we start off in a situation where either species could persist alone with the disease, in the absence of vaccination and the species that ‘wins’ is determined by the initial conditions. If we consider vaccinating only species i ($i=1,2$) then we give species i the advantage and that species can persist in the absence of species j under certain sufficiently high vaccination rates. However, when the vaccination rate of species i is increased further then the two species can persist together for the reasons discussed above. If we vaccinate both species it is again possible to achieve uninfected coexistence.

3. The case studies: A target-reservoir system.

We will now apply these results to a general system of biological interest. In line with the paper by Haydon et al 2002 a target population is defined as the population of concern or interest to us. Pathogens will persist in populations larger than the critical community size and these populations will be termed maintenance populations. All other potentially susceptible host populations that are epidemiologically connected to the target population are non-target populations and constitute the reservoir. A reservoir is one or more epidemiologically connected populations or environments in which the pathogen can be permanently maintained and from which infection is transmitted to the defined target population (Haydon et al 2002). In practical terms reservoirs will generally become important either when the target population cannot maintain the disease alone or when control in the target population means that the amount of between species infection is large compared to the within species infection. In terms of the model presented here, we will consider two particular scenarios. (i) A system in which, in the absence of vaccination, neither species alone would allow the disease to persist but when the two species are present together they allow coexistence of the pathogen with both hosts. (ii) A system in which in the absence of vaccination, the target host alone would not permit the disease to persist but the presence of the second reservoir host causes the target species to die out. We will look at each of these cases separately.

Case 1: The disease cannot persist with either species alone.

This is a special case of scenario 2. It is not a true target- reservoir system as defined above because the pathogen could not persist with either species alone but their combined presence allows persistence. However, it is a simple example and will be useful for the case which follows.

In this system since the disease cannot persist with either species alone then we know that

$$R_i < 1 \quad i=1,2 \quad \text{with} \quad R_i = \frac{\beta_{ii}K_i(b_i + \gamma_i)}{\Gamma_i(b_i + \nu_i + \gamma_i)}$$

This implies that $\nu_{iT} < 0$ and we have eradication of the disease even when there is no vaccination. We will assume that we are starting with no vaccination in either species. This is not essential, but facilitates the description of what happens when we increase the vaccination rates.

In addition to the above conditions, we know that the disease can persist when both species are present together which means that we have

$$(1 - R_1)(1 - R_2) < R_{12}R_{21} \quad (8)$$

Note that this is the opposite of the condition for stability of equilibrium E4 (equation 4). Here all of the effective reproductive numbers depend inversely on ν_i . In order to eradicate the disease we must reverse inequality (8) so that the coexistence equilibrium is no longer stable and the equilibrium in which both species coexist at their carrying capacities becomes stable. Increasing ν_i causes both R_{ij} and R_i to decrease, this means that $(1 - R_i)$ increases and so the inequality will eventually be reversed. However, we can see that it does not matter which species we vaccinate, we can vaccinate one, or the other, or both and we will eventually be able to eradicate the disease. This is illustrated in figure 4.

Case 2: Species one eradicated

This is a special case of scenario 5. In this example, the disease could not persist in species one alone but the presence of species 2 allows it to persist and the consequence is that species 1 dies out. This is an extreme case of the target- reservoir system.

Here we must have $R_1 < 1$ (i.e., $\nu_{1T} < 0$) and the $(0, 0, 0, Y_2^*, Z_2^*, H_2^*)$ equilibrium (E6) stable and hence and $R_2 > 1$ (i.e., $\nu_{2T} > 0$) and

$$r_1 < \frac{\alpha_1 \beta_{12} Y_2^*(\nu_2)}{\beta_{12} Y_2^*(\nu_2) M_1 + \Gamma_1 \phi_1(\nu_1)} \quad (9)$$

Where, $Y_2^* = \frac{1}{M_2} \left(H_2^* - \frac{K_2}{R_2} \right)$, $\phi_2 = \frac{b_2 + \nu_2 + \gamma_2}{b_2 + \gamma_2}$, $M_2 = \frac{b_2 + \gamma_2 + \mu_2}{b_2 + \gamma_2}$ and

$$H_1^* = \frac{K_1}{2} \left(1 - \varepsilon_1 + \sqrt{(\varepsilon_1 - 1)^2 + 4 \frac{\varepsilon_1}{R_1}} \right) \text{ with } \varepsilon_2 = \frac{\alpha_2}{r_2 M_2}.$$

Again, we will assume that there is no vaccination initially. We can see from this that ϕ_i increases as we vaccinate species i and again, the R_i terms depend inversely on vaccination of species i . This means that there is an increase in H_2^* with an increase in ν_2 and then, ultimately a decrease in Y_2^* (see Appendix B for full details). If we rearrange inequality (9)

$$Y_2^* > \frac{\Gamma_1 r_1 \phi_1}{\beta_{12} (\alpha_1 - r_1 M_1)} \quad (10)$$

we can see that there is a threshold value for Y_2^* . Eventually increasing the vaccination rate (from our initial rate of zero) for species 2 reduces Y_2^* below this threshold and so the $(0, 0, 0, Y_2^*, Z_2^*, H_2^*)$ equilibrium is no longer stable. We then get coexistence of both species with the pathogen. At this point we still have $R_2 > 1$. However if we then continue to increase ν_2 then we can decrease R_2 sufficiently until this threshold is also reversed. We are then back in case 1 and if we continue to increase the vaccination rate of species 2 then we can reverse inequality (8) and eradicate the disease.

Alternatively, if we vaccinate species 1 then the only effect on inequality (9) is to increase ϕ_1 . However, if we increase ν_1 sufficiently then we can reverse inequality (9). We then get both species coexisting with the pathogen. In this case, however, it is not possible to increase ν_1 enough to eradicate the disease since species 2 can maintain the disease alone.

This means that in a system which fits this description, vaccinating the target species will have some benefit, allowing it to persist where it would not without

vaccination, but will not ultimately eradicate the disease. However, vaccinating the reservoir species makes it possible to eradicate the disease. This is illustrated in figure 8. It is likely to be more practical to vaccinate species 1 at least initially to get to coexistence but we then have to vaccinate species 2 if we wish to eradicate the disease.

4. Proportional vaccination:

Thus far we have modelled vaccination as a continuous fixed rate. An alternative is to use proportional vaccination; this will also allow us to use the method of Roberts and Heesterbeek (2003) to determine the proportion of a species which we need to vaccinate in order to eradicate the disease. The simplest approach in this case is to assume that we vaccinate at birth (Anderson and May 1991) and therefore a proportion of those born are born into the immune class. It should be noted that this assumes that there is no waning of immunity and that vaccinated individuals are immunologically the same as those which have recovered from the disease, again this is done for simplicity and more complex mechanisms will be added to the model in later papers. Equation 2 now becomes

$$\frac{dZ_i}{dt} = \mu_i Y_i - b_i Z_i - \gamma_i Z_i + p_i \left(a_i - \frac{r_i H_i}{K_i} \right) H_i$$

Where a_i is the per capita birth rate for species i and p_i is the proportion of species i which is vaccinated at birth. The remaining equations are unchanged. Regardless of our method of analysis we find that with one species we need

$$p > \left(1 - \frac{1}{R_0} \right) \frac{(b + \gamma)}{b} \text{ in order to eradicate the pathogen where}$$

$R_0 = \frac{\beta K}{\Gamma}$ and γ is the rate of loss of immunity. This result is consistent with the results of Woolhouse et al 1997, it should be noted that if there is no loss of immunity, i.e., if $\gamma = 0$ then $p > \left(1 - \frac{1}{R_0} \right)$ which is the more traditionally quoted formula.

If we have two species interacting via a pathogen and we are going to treat one of them, Roberts and Heesterbeek (2003) have developed a method of analysis to determine what proportion of the host to be treated, we need to vaccinate to eradicate the disease. It should be noted that we have to modify their results slightly by including the factor $\frac{b+\gamma}{b}$, in order to take into account the fact that there is loss of immunity (see below).

Firstly we form the next generation matrix for our particular system, following the method of Diekmann and Heesterbeek (2000)

$$K = \begin{pmatrix} \frac{\beta_{11}K_1}{\Gamma_1} & \frac{\beta_{21}K_1}{\Gamma_1} \\ \frac{\beta_{12}K_2}{\Gamma_2} & \frac{\beta_{22}K_2}{\Gamma_2} \end{pmatrix}$$

Then, the modified version of Roberts and Heesterbeek's method states that if we are vaccinating species 2, for example, then we need

$$p_2 > \left(1 - \frac{1}{T_2}\right) \left(\frac{b_2 + \gamma_2}{b_2}\right)$$

for eradication of the pathogen, where

$$T_2 = e_2^T K(I - (I - P_2)K)^{-1} e_2 \quad \text{with } e_2 = \begin{pmatrix} 0 \\ 1 \end{pmatrix}, \quad I = \begin{pmatrix} 1 & 0 \\ 0 & 1 \end{pmatrix} \quad \text{and } P_2 = \begin{pmatrix} 0 & 0 \\ 0 & 1 \end{pmatrix}$$

For the system presented here

$$T_2 = \frac{\beta_{12}\beta_{21}K_1K_2 + \beta_{22}\beta_{11}K_2\left(\frac{\Gamma_1}{\beta_{11}} - K_1\right)}{\beta_{22}\beta_{11}\left(\frac{\Gamma_2}{\beta_{22}}\right)\left(\frac{\Gamma_1}{\beta_{11}} - K_1\right)}$$

and

$$T_1 = \frac{\beta_{12}\beta_{21}K_1K_2 + \beta_{22}\beta_{11}K_1\left(\frac{\Gamma_2}{\beta_{22}} - K_2\right)}{\beta_{22}\beta_{11}\left(\frac{\Gamma_1}{\beta_{11}}\right)\left(\frac{\Gamma_2}{\beta_{22}} - K_2\right)}$$

This formula can also be derived by rearranging the equivalent of inequality (4) with proportional vaccination in one species. For a parameterised system we can therefore estimate the proportion of species 2 which would have to be vaccinated for the pathogen to be eradicated. However, it can be shown that p_1 does not lie between 0 and 1, when we are in case 2. These results confirm that we cannot eradicate the pathogen by vaccinating species 1 alone under those circumstances (appendix C). It should be noted that this approach is limited in that it does not allow vaccination of both species.

5. Discussion

In this paper we have looked at the effect of vaccination on a host-host pathogen system. We made some deliberately simplifying assumptions in this model so that the effect of vaccination is the same as that of natural immunity through exposure, also the vaccination strategy was either to vaccinate at a fixed rate, or to vaccinate a fixed proportion of individuals at birth. More complicated vaccination strategies or mechanisms which can now be added to this baseline model include waning of immunity or imperfect vaccines (e.g. Moghadas 2004), pulse vaccination (e.g. Zhou and Liu 2003, D’Onofrio 2002) and ring vaccination (e.g. Del Valle et al 2005).

In our analysis we determined the different possible types of long term behaviour and the conditions, in terms of the parameters which allow each possibility to occur. These were then presented as joint threshold curves in $\nu_1 - \nu_2$ space, which allow us to determine the long term effects of vaccinating each of the two species individually, or both species together. Vaccination can have two effects. The first is to protect a species directly and hence allow it to increase in density. The second is to reduce the disease in the second species and hence reduce the amount of apparent competition that the original species is subject to, again allowing it to increase in density.

We then looked at two case studies to help us to determine the effect of vaccination in the case when we have a target – reservoir system. It was found that in the case where the target cannot sustain the disease alone and the reservoir can, if when we put the two species together and the target species is eradicated, then it is possible to allow the two species to coexist with the disease by vaccinating the target species, but it is not possible to eradicate the disease unless we also vaccinate the reservoir species. However, we could both allow coexistence of both species with the pathogen and then, for high enough vaccination rate, eradicate the disease if we only vaccinate the reservoir species. This result also holds if the vaccination is added to the model as proportional vaccination at birth.

Unfortunately, since for these types of systems, the target host is most likely to be a domestic species and the reservoir host is most likely to be a wild species then it may not be practical to vaccinate the reservoir and so, the best case may be to achieve

coexistence of the two species with the pathogen. On the other hand, if we were considering, for example, red and grey squirrels with a parapoxvirus (Tompkins et al 2003), then red squirrels could be considered the target and grey squirrels the reservoir. In this case vaccinating either species would be difficult since they are both wild, but in fact, because they are initially more abundant, then vaccinating the reservoir species might be easier, at least in the first instance.

It is also clear that vaccination campaigns may have to change over time in response to the consequent changes in abundance of each species. This has not yet been addressed with this model.

The model and results presented here are general and could be applied to any directly transmitted pathogen which infects two hosts, or indeed could be applied to a pathogen which infects two related species of the same host, e.g. a susceptible and resistant species of host. We have presented an analysis of the model that could then be used as a baseline to answer specific questions about what the best vaccination approach is for any particular system for which parameter estimates are available.

References:

Anderson, RM and May RM (1981) The Population Dynamics of Microparasites and their Invertebrate Hosts *Phil Tran R Soc Lond B* 291: 451-524.

Anderson RM and May RM (1991) *Infectious Diseases of Humans, Dynamics and Control*. Oxford Science Publications.

Arino, J., Cook, K.L., Van der Driessche, P., Venasco-Hernandez, J (2004) An Epidemiology Model that Includes a Leaky Vaccine with a General Waning Function. *Discrete and continuous dynamical systems- series B* 4(2) 479-495.

Begon, M and Bowers, RG (1995) Host-host Pathogen Models and Microbial Pest Control: The Effect of Host Self Regulation. *J Theor Biol* 169: 275-287

Bowers, RG and Turner J (1997) Community Structure and Interplay Between Interspecific Infection and Competition. *J. Theor. Biol* 187: 95-109.

Cleaveland, S, Laurenson, MK and Taylor, LH (2001) Diseases of Humans and their Domestic Mammals; Pathogen Characteristics, Host Range and the Risk of Emergence. *Phil.Trans R Soc Lond B Biol Sci* 356: 991-999.

Del Valle, S, Hethcote, H, Hyman, JM and Castillo-Chaves, C (2005) Effects of Behavioural Changes in a Small Pox Attack Model. *Mathematical Biosciences* 195(2) 228-251.

Diekmann, O and Heesterbeek, JAP (2000) Mathematical Epidemiology of Infectious Diseases, Model building, analysis and interpretation. Chichester, UK. Wiley.

D'Onofrio A (2002) Pulse Vaccination Strategy in the SIR Epidemic Model: Global Asymptotic Stable Eradiction in the Presence of Vaccine Failures. *Mathematical and Computer Modelling*. 36(4-5) 473-489.

Haydon, DT, Cleaveland, S, Taylor, LH and Laurenson, MK (2002) Identifying Reservoirs of Infection: A Conceptual and Practical Challenge. *Emerging Infectious Diseases* 8(12): 1468-1473.

Holt RD and Pickering J (1985) Infectious Disease and Species Coexistence: a Model in Lotka – Volterra Form. *Am Nat* 126: 196-211.

Kribs-Zaleta, CM, Velasco-Hernandez, JX (2000) A Simple Vaccination Model with Multiple Endemic States. *Mathematical Biosciences* 164(2) 183-201.

Moghadas, SM (2004) Modelling the Effect of Imperfect Vaccines on Disease Epidemiology. *Discrete and continuous dynamical systems- Series B* 4(4) 999-1012.

Roberts MG and Heesterbeek JAP (2003) A New Method for Estimating the Effort Required to Control an Infectious Disease. *Proceedings of the Royal Society of London, B*. 270: 1359-1364.

Tompkins, DM, White AR and Boots, M (2003) Ecological Replacement of Native Red Squirrels by Invasive Greys Driven by Disease. *Ecology Letters* 6(3): 189-196.

Woolhouse, MEJ, Haydon, DT and Bundy, DAP (1997) The Design of Veterinary Vaccination Programmes. *The Veterinary Journal* 153: 41-47.

Zhou, YC and Liu HW (2003) Stability of Periodic Solutions for an SIS Model with Pulse Vaccination. *Mathematical and Computer modelling*. 38(3-4) 299-308.

Appendix A:

In order to look at the long-term behaviour of this system (equations 1-3) we need to calculate the possible equilibria. These are calculate by setting the derivatives of equations (1)-(3) with $i,j=1,2$ equal to zero. This gives us the following equations:

$$\begin{aligned}
 \beta_{11}X_1Y_1 + \beta_{12}X_1Y_2 - \Gamma_1Y_1 &= 0 \\
 \mu_1Y_1 + \nu_1X_1 - b_1Z_1 - \gamma_1Z_1 &= 0 \\
 r_1H_1\left(1 - \frac{H_1}{K_1}\right) - \alpha_1Y_1 &= 0 \\
 \beta_{22}X_2Y_2 + \beta_{21}X_2Y_1 - \Gamma_2Y_2 &= 0 \\
 \mu_2Y_2 + \nu_2X_2 - b_2Z_2 - \gamma_2Z_2 &= 0 \\
 r_2H_2\left(1 - \frac{H_2}{K_2}\right) - \alpha_2Y_2 &= 0
 \end{aligned} \tag{A1}$$

Solving these equations gives us 7 biologically relevant (i.e. positive) solutions, each of which will be discussed below. Once we have determined formulae for each equilibrium we look at when it is stable. In order to determine this we study the eigenvalues of the Jacobian evaluated at the equilibrium in question. If these eigenvalues have negative real parts then the equilibrium is stable.

The general form of the Jacobian for equations (1)-(3) is as follows:

$$\begin{pmatrix}
 \beta_{11}(H_1 - 2Y_1 - Z_1) & -\beta_{11}Y_1 - \beta_{12}Y_2 & \beta_{11}Y_1 + \beta_{12}Y_2 & \beta_{12}(H_1 - Y_1 - Z_1) & 0 & 0 \\
 -\beta_{12}Y_2 - \Gamma_1 & \mu_1 - \nu_1 & -\nu_1 - b_1 - \gamma_1 & \nu_1 & 0 & 0 \\
 -\alpha_1 & 0 & r_1 - \frac{2r_1H_1}{K_1} & 0 & 0 & 0 \\
 \beta_{21}(H_2 - Y_2 - Z_2) & 0 & 0 & \beta_{22}(H_2 - 2Y_2 - Z_2) & -\beta_{22}Y_2 - \beta_{21}Y_1 & \beta_{22}Y_2 + \beta_{21}Y_1 \\
 0 & 0 & 0 & -\beta_{21}Y_1 - \Gamma_2 & \mu_2 - \nu_2 & -\nu_2 - b_2 - \gamma_2 \\
 0 & 0 & 0 & -\alpha_2 & 0 & r_2 - \frac{2r_2H_2}{K_2}
 \end{pmatrix}$$

We will now consider each equilibrium and its stability, as discussed in the text, in turn.

- 1) $(0,0,0,0,0,0)$ is the simplest possible equilibrium, to see when this is stable we use the following Jacobian:

$$\begin{pmatrix} -\Gamma_1 & 0 & 0 & 0 & 0 & 0 \\ \mu_1 - \nu_1 & -\nu_1 - b_1 - \gamma_1 & \nu_1 & 0 & 0 & 0 \\ -\alpha_1 & 0 & r_1 & 0 & 0 & 0 \\ 0 & 0 & 0 & -\Gamma_2 & 0 & 0 \\ 0 & 0 & 0 & \mu_2 - \nu_2 & -\nu_2 - b_2 - \gamma_2 & \nu_2 \\ 0 & 0 & 0 & -\alpha_2 & 0 & r_2 \end{pmatrix}$$

It can be seen that, given all other parameters positive for biological realism, the eigenvalues of this Jacobian would only be negative when $r_i < 0$, with $i = 1, 2$ in other words when the net growth rate of both of the host species is negative.

2) The equilibrium where species 1 is alone at its carrying capacity is given

by $\left(0, \frac{\nu_1 K_1}{\nu_1 + b_1 + \gamma_1}, K_1, 0, 0, 0\right)$. Its stability is determined by the following Jacobian

$$\begin{pmatrix} \beta_{11}\left(K_1 - \frac{\nu_1 K_1}{\nu_1 + b_1 + \gamma_1}\right) - \Gamma_1 & 0 & 0 & \beta_{12}\left(K_1 - \frac{\nu_1 K_1}{\nu_1 + b_1 + \gamma_1}\right) & 0 & 0 \\ \mu_1 - \nu_1 & -\nu_1 - b_1 - \gamma_1 & \nu_1 & 0 & 0 & 0 \\ -\alpha_1 & 0 & -r_1 & 0 & 0 & 0 \\ 0 & 0 & 0 & 0 - \Gamma_2 & 0 & 0 \\ 0 & 0 & 0 & \mu_2 - \nu_2 & -\nu_2 - b_2 - \gamma_2 & \nu_2 \\ 0 & 0 & 0 & -\alpha_2 & 0 & r_2 \end{pmatrix}$$

This equilibrium is stable if $R_1 < 1$ and $r_2 < 0$ that is, if species 2 has negative net growth rate.

3) Similarly, the equilibrium where species 2 is alone at its carrying capacity is given by

$\left(0, 0, 0, \frac{\nu_2 K_2}{\nu_2 + b_2 + \gamma_2}, K_2\right)$ and is only stable when species 1 has a negative growth rate.

4) The equilibrium where both species are present at their carrying capacity is given by

$\left(0, \frac{\nu_1 K_1}{\nu_1 + b_1 + \gamma_1}, K_1, 0, \frac{\nu_2 K_2}{\nu_2 + b_2 + \gamma_2}, K_2\right)$. In this case the Jacobian is:

$$\begin{pmatrix} \beta_{11}\left(K_1 - \frac{\nu_1 K_1}{\nu_1 + b_1 + \gamma_1}\right) - \Gamma_1 & 0 & 0 & \beta_{12}\left(K_1 - \frac{\nu_1 K_1}{\nu_1 + b_1 + \gamma_1}\right) & 0 & 0 \\ \mu_1 - \nu_1 & -\nu_1 - b_1 - \gamma_1 & \nu_1 & 0 & 0 & 0 \\ -\alpha_1 & 0 & -r_1 & 0 & 0 & 0 \\ \beta_{21}\left(K_2 - \frac{\nu_2 K_2}{\nu_2 + b_2 + \gamma_2}\right) & 0 & 0 & \beta_{22}\left(K_2 - \frac{\nu_2 K_2}{\nu_2 + b_2 + \gamma_2}\right) - \Gamma_2 & 0 & 0 \\ 0 & 0 & 0 & \mu_2 - \nu_2 & -\nu_2 - b_2 - \gamma_2 & \nu_2 \\ 0 & 0 & 0 & -\alpha_2 & 0 & -r_2 \end{pmatrix}$$

which has eigenvalues $-\nu_1 - b_1 - \gamma_1$, $-\nu_2 - b_2 - \gamma_2$, $-r_1$, $-r_2$ and the eigenvalues of

$$\begin{pmatrix} \beta_{11} \left(\frac{K_1(b_1 + \gamma_1)}{\nu_1 + b_1 + \gamma_1} \right) - \Gamma_1 & \beta_{12} \left(\frac{K_1(b_1 + \gamma_1)}{\nu_1 + b_1 + \gamma_1} \right) \\ \beta_{21} \left(\frac{K_2(b_2 + \gamma_2)}{\nu_2 + b_2 + \gamma_2} \right) & \beta_{22} \left(\frac{K_2(b_2 + \gamma_2)}{\nu_2 + b_2 + \gamma_2} \right) - \Gamma_2 \end{pmatrix}. \text{ Clearly the first four solutions are negative}$$

so we only need to consider the eigenvalues of the remaining 2x2 matrix. In that case we

find that if we write $R_i = \frac{\beta_{ii} K_i (b_i + \gamma_i)}{\Gamma_i (b_i + \nu_i + \gamma_i)}$ then we get the following characteristic equation:

$$\lambda^2 + \lambda(\Gamma_1(1 - R_1) + \Gamma_2(1 - R_2)) + \Gamma_1 \Gamma_2 ((1 - R_1)(1 - R_2) - R_{12} R_{21}) = 0$$

which gives eigenvalues with negative real parts if and only if $R_i < 1$ for $i=1$ and 2 , and

$$(1 - R_1)(1 - R_2) > R_{12} R_{21}.$$

5) The equilibrium where species 1 persist alone with the disease is given by

$(Y_1^*, Z_1^*, H_1^*, 0, 0)$ where H_1^* is the positive solution of

$$\frac{H_1^{*2}}{K_1^2} + \frac{H_1^*}{K_1} (\varepsilon_1 - 1) - \frac{\varepsilon_1}{R_1} = 0 \text{ where } \varepsilon_1 = \frac{\alpha_1}{r_1 M_1} \text{ and } M_1 = \frac{b_1 + \gamma_1 + \mu_1}{b_1 + \gamma_1}. \text{ In other words}$$

$$H_1^* = \frac{K_1}{2} \left(1 - \varepsilon_1 + \sqrt{(\varepsilon_1 - 1)^2 + 4 \frac{\varepsilon_1}{R_1}} \right) \text{ which is always positive. In addition we have}$$

$$Y_1^* = \frac{1}{M_1} \left(H_1^* - \frac{K_1}{R_1} \right) \text{ and } Z_1^* = \frac{\mu_1 Y_1^*}{b_1 + \gamma_1} + \frac{\nu_1 \Gamma_1}{\beta_{11} (b_1 + \gamma_1)}, Y_1^* \text{ can be shown to be positive if and}$$

only if $R_1 > 1$ and if Y_1^* is positive then so is Z_1^* .

When we consider stability, the Jacobian is as follows:

$$\begin{pmatrix} \beta_{11}(H_1^* - 2Y_1^* - Z_1^*) - \Gamma_1 & -\beta_{11}Y_1^* & \beta_{11}Y_1^* & \beta_{12}(H_1^* - Y_1^* - Z_1^*) & 0 & 0 \\ \mu_1 - \nu_1 & -\nu_1 - b_1 - \gamma_1 & \nu_1 & 0 & 0 & 0 \\ -\alpha_1 & 0 & r_1 - \frac{2r_1 H_1^*}{K_1} & 0 & 0 & 0 \\ 0 & 0 & 0 & -\beta_{21}Y_1^* - \Gamma_2 & -\beta_{21}Y_1^* & \beta_{21}Y_1^* \\ 0 & 0 & 0 & \mu_2 - \nu_2 & -\nu_2 - b_2 - \gamma_2 & \nu_2 \\ 0 & 0 & 0 & -\alpha_2 & 0 & r_2 \end{pmatrix}$$

When we calculate the eigenvalues of this matrix we can split it into two 3x3 matrices.

After some simplification we get the following:

$$\begin{vmatrix} -\beta_{11}Y_1^* - \lambda & -\beta_{11}Y_1^* & \beta_{11}Y_1^* \\ \mu_1 - \nu_1 & -\nu_1 - b_1 - \gamma_1 - \lambda & \nu_1 \\ -\alpha_1 & 0 & r_1 - \frac{2r_1H_1^*}{K_1} - \lambda \end{vmatrix} = 0 \quad (\text{A2})$$

and

$$\begin{vmatrix} -\beta_{21}Y_1^* - \Gamma_2 - \lambda & -\beta_{21}Y_1^* & \beta_{21}Y_1^* \\ \mu_2 - \nu_2 & -\nu_2 - b_2 - \gamma_2 - \lambda & \nu_2 \\ -\alpha_2 & 0 & r_2 - \lambda \end{vmatrix} = 0 \quad (\text{A3})$$

If we first consider the eigenvalues of A2 we find that this is the Jacobian we would have if we simply considered the single host system. The eigenvalues therefore have negative real parts if and only if $R_1 > 1$.

If we consider A3 we get the following characteristic equation:

$$\lambda^3 + A\lambda^2 + B\lambda + C = 0$$

where

$$A = \beta_{21}Y_1^* + \Gamma_2 - r_2 + \nu_2 + b_2 + \gamma_2$$

$$B = \beta_{21}Y_1^* (\mu_2 + b_2 + \gamma_2 + \alpha_2 - r_2) + (\Gamma_2 - r_2)(\nu_2 + b_2 + \gamma_2) - r_2\Gamma_2$$

$$C = (b_2 + \gamma_2)(\beta_{21}Y_1^* (\alpha_2 - r_2M_2) - \Gamma_2r_2\phi_2)$$

The Routh Hurwitz conditions say that the solutions of this cubic will have negative real parts if $A, B, C > 0$ and $AB > C$. It can be shown that if $\beta_{21}Y_1^* \alpha_2 > \beta_{21}Y_1^* r_2M_2 + \Gamma_2r_2\phi_2$ then $A, B, C > 0$. It has not yet been possible to show that $AB > C$. This implies the possibility of limit cycles.

- 6) The equilibrium with species 2 present alone with the disease will be stable under the same conditions as above, with the 1s and 2s in the subscripts interchanged.

When the conditions shown in 5) and 6) are both satisfied at the same time then (modulo the possibility of cycles) both equilibria are stable and the outcome is contingent on the initial conditions.

Due to the algebraic intractabilities involved in this analysis we assume that if none of the above equilibria are stable then either the coexistence equilibrium is stable or we have

stable limit cycles with both species present with the disease (but see main text for more detail).

Appendix B

We are in a system in which $R_1 < 1$ and the $(0,0,0, Y_2^*, Z_2^*, H_2^*)$ equilibrium is stable and hence $R_2 > 1$ and $r_2 < \frac{\alpha_2 \beta_{21} Y_1^*}{\beta_{21} Y_1^* M_2 + \Gamma_2 \phi_2}$

Where, $Y_1^* = \frac{1}{M_1} \left(H_1^* - \frac{K_1}{R_1} \right)$, $\phi_1 = \frac{b_1 + \nu_1 + \gamma_1}{b_1 + \gamma_1}$, $M_1 = \frac{b_1 + \gamma_1 + \mu_1}{b_1 + \gamma_1}$ and

$$H_1^* = \frac{K_1}{2} \left(1 - \varepsilon_1 + \sqrt{(\varepsilon_1 - 1)^2 + 4 \frac{\varepsilon_1}{R_1}} \right) \text{ with } \varepsilon_1 = \frac{\alpha_1}{r_1 M_1} \beta_{12} Y_2^* \alpha_1 > \beta_{12} Y_2^* r_1 M_1 + \Gamma_1 r_1 \phi_1$$

We wish to determine what happens as we increase the rate at which we vaccinate species 2. i.e as ν_2 increases. We can see immediately that R_2 decreases as we vaccinate species 2 and that this means an increase in H_2^* . We must now determine what happens to Y_2^* as a consequence of this. From $Y_2^* = \frac{r_2 H_2^*}{\alpha_2} \left(1 - \frac{H_2^*}{K_2} \right)$ (which comes from setting the derivative of equation 3 to zero) we can see that if $H_2^* = 0$ then $Y_2^* = 0$, as H_2^* increases then so does Y_2^* until $H_2^* = \frac{K_2}{2}$ after which Y_2^* decreases with increasing H_2^* . Therefore if $H_2^* > \frac{K_2}{2}$ then increasing ν_2 will cause a decrease in Y_2^* . However if $H_2^* < \frac{K_2}{2}$ then increasing ν_2 will cause an initial increase in Y_2^* before a decrease occurs. This may seem counter intuitive since if we vaccinate a species we should expect a decrease in the density of infectious individuals. However if we look at the circumstances under which $H_2^* < \frac{K_2}{2}$ we find that this occurs iff

$$4 \frac{\varepsilon_2}{R_2} - 2\varepsilon_2 + 1 < 0$$

One cause of this would be high K_2 . If we increase the vaccination rate under these circumstances, then the total population increases rapidly and there is a consequent increase in the density of infecteds but the prevalence of infection decreases, so that overall, the result is what we expect intuitively. Eventually, if ν_2 is high enough then Y_2^* will decrease.

If we then look at how this eventual decrease in Y_2^* affects the stable equilibrium we need to consider inequality (5). For this inequality to hold in the first place we must have $\alpha_1 > r_1 M_1$, we can therefore rearrange it to get

$$Y_2^* > \frac{\Gamma_1 r_1 \phi_1}{\beta_{12} (\alpha_1 - r_1 M_1)} > 0$$

and, as discussed in the main text, once Y_2^* drops below this threshold then the $(0, 0, 0, Y_2^*, Z_2^*, H_2^*)$ equilibrium becomes unstable and we get coexistence of both species with the pathogen.

Appendix C

We wish to prove that when we are in case 2 then we cannot have $0 < p_1 < 1$ and therefore we cannot eradicate the disease by vaccinating species 1. Here

$$p_1 = \left(1 - \frac{1}{T_1}\right) \left(\frac{b_1 + \gamma_1}{b_1}\right) \text{ and } T_1 = \frac{\beta_{12}\beta_{21}K_1K_2 + \beta_{22}\beta_{11}K_1\left(\frac{\Gamma_2}{\beta_{22}} - K_2\right)}{\beta_{22}\beta_{11}\left(\frac{\Gamma_1}{\beta_{11}}\right)\left(\frac{\Gamma_2}{\beta_{22}} - K_2\right)}.$$

Now, in case 2 we have $R_1 < 1$ and $R_2 > 1$ which means that, without vaccination we have $\Gamma_1 > \beta_{11}K_1$ and $\Gamma_2 < \beta_{22}K_2$.

$$\text{Now } p_1 = \left(1 - \frac{1}{T_1}\right) \left(\frac{b_1 + \gamma_1}{b_1}\right) = \left(\frac{b_1 + \gamma_1}{b_1}\right) \left(\frac{\beta_{12}\beta_{21}K_1K_2 + (\beta_{11}K_1 - \Gamma_1)(\Gamma_2 - \beta_{22}K_2)}{\beta_{12}\beta_{21}K_1K_2 + \beta_{11}K_1(\Gamma_2 - \beta_{22}K_2)}\right)$$

We therefore want to know if

$$\left(\frac{b_1}{b_1 + \gamma_1}\right) > \left(\frac{\beta_{12}\beta_{21}K_1K_2 + (\beta_{11}K_1 - \Gamma_1)(\Gamma_2 - \beta_{22}K_2)}{\beta_{12}\beta_{21}K_1K_2 + \beta_{11}K_1(\Gamma_2 - \beta_{22}K_2)}\right) > 0$$

The denominator of this term can be either positive or negative.

If $\beta_{12}\beta_{21}K_1K_2 + \beta_{11}K_1(\Gamma_2 - \beta_{22}K_2) > 0$ then we need to know if

$$\left(\frac{b_1}{b_1 + \gamma_1}\right) (\beta_{12}\beta_{21}K_1K_2 + \beta_{11}K_1(\Gamma_2 - \beta_{22}K_2)) > \beta_{12}\beta_{21}K_1K_2 + (\beta_{11}K_1)(\Gamma_2 - \beta_{22}K_2) - \Gamma_1(\Gamma_2 - \beta_{22}K_2)$$

and if $\beta_{12}\beta_{21}K_1K_2 + (\beta_{11}K_1 - \Gamma_1)(\Gamma_2 - \beta_{22}K_2) > 0$

The second inequality holds but the first does not since the $-\Gamma_1(\Gamma_2 - \beta_{22}K_2)$ is positive

and so increases the right hand side and the $\frac{b_1}{b_1 + \gamma_1}$ term decreases the left hand side.

This means that when $\beta_{12}\beta_{21}K_1K_2 + \beta_{11}K_1(\Gamma_2 - \beta_{22}K_2) > 0$ we cannot find a value of p_1 which allows us to eradicate the pathogen.

Similarly when $\beta_{12}\beta_{21}K_1K_2 + \beta_{11}K_1(\Gamma_2 - \beta_{22}K_2) < 0$ then we need to know if

$$\left(\frac{b_1}{b_1 + \gamma_1}\right) (\beta_{12}\beta_{21}K_1K_2 + \beta_{11}K_1(\Gamma_2 - \beta_{22}K_2)) < \beta_{12}\beta_{21}K_1K_2 + (\beta_{11}K_1)(\Gamma_2 - \beta_{22}K_2) - \Gamma_1(\Gamma_2 - \beta_{22}K_2)$$

and $\beta_{12}\beta_{21}K_1K_2 + (\beta_{11}K_1 - \Gamma_1)(\Gamma_2 - \beta_{22}K_2) < 0$ in this case it is clearly the second inequality which does not hold since both terms in the brackets are negative and so the whole of the left hand side is positive.

We therefore, cannot find a value of $0 < p_1 < 1$ for which we can eradicate the disease for a system described by case 2, or indeed any system where species 1 could not maintain the disease alone and species 2 can.

Table 1. Definition of parameters used in equations (1) – (3)

Parameter	Definition
β_{ii}	Within species transmission rate
β_{ij}	Between species transmission rate (species j to species i)
α_i	Per capita disease induced death rate for species i
b_i	Disease free per capita death rate for species i
μ_i	Per capita rate of recovery to immunity
Γ_i	$\alpha_i + b_i + \mu_i$
v_i	Per capita rate of vaccination of species i
γ_i	Per capita rate of loss of immunity
K_i	Carrying capacity of species i
a_i	Per capita birth rate
$r_i = a_i - b_i$	Intrinsic population growth rate of species i

Table 2

Areas of parameter space and the stable equilibrium for that region:

Area of parameter space	Stable Equilibrium
$a_1 < b_1$ $a_2 < b_2$ in other words $r_1 < 0$ $r_2 < 0$	E1
$a_1 > b_1$ $a_2 < b_2$ in other words $r_1 > 0$ $r_2 < 0$	E2
$a_1 < b_1$ $a_2 > b_2$ in other words $r_1 < 0$ $r_2 > 0$	E3
$r_1 > 0$ $r_2 > 0$ and ...	
$R_1 < 1$, $R_2 < 1$ and $(1 - R_1)(1 - R_2) > R_{12}R_{21}$	E4
$R_1 > 1$, $r_2 < \frac{\alpha_2 \beta_{21} Y_1^*}{\beta_{21} Y_1^* M_2 + \Gamma_2 \phi_2}$ and $A_1 B_1 > C_1$	E5
$R_1 > 1$, $r_2 < \frac{\alpha_2 \beta_{21} Y_1^*}{\beta_{21} Y_1^* M_2 + \Gamma_2 \phi_2}$ and $A_1 B_1 < C_1$	Stable cycles about E5
$R_2 > 1$, $r_1 < \frac{\alpha_1 \beta_{12} Y_2^*}{\beta_{12} Y_2^* M_1 + \Gamma_1 \phi_1}$ and $A_2 B_2 > C_2$	E6
$R_2 > 1$, $r_1 < \frac{\alpha_1 \beta_{12} Y_2^*}{\beta_{12} Y_2^* M_1 + \Gamma_1 \phi_1}$ and $A_2 B_2 < C_2$	Stable cycles about E6
$R_1 > 1$, $R_2 > 1$, $r_2 < \frac{\alpha_2 \beta_{21} Y_1^*}{\beta_{21} Y_1^* M_2 + \Gamma_2 \phi_2}$ and $r_1 < \frac{\alpha_1 \beta_{12} Y_2^*}{\beta_{12} Y_2^* M_1 + \Gamma_1 \phi_1}$	Contingency, so either E5 or E6 is stable (or cycles), the initial conditions determine which one.
$R_1 > 1$, $R_2 > 1$, $r_2 > \frac{\alpha_2 \beta_{21} Y_1^*}{\beta_{21} Y_1^* M_2 + \Gamma_2 \phi_2}$, $r_1 > \frac{\alpha_1 \beta_{12} Y_2^*}{\beta_{12} Y_2^* M_1 + \Gamma_1 \phi_1}$ and $(1 - R_1)(1 - R_2) < R_{12}R_{21}$	Coexistence equilibrium assumed to be stable, or cycles about a coexistence equilibrium.

Figure legends:

Figure 1: Flow diagram to illustrate interactions in the model.

Figure 2: Graph to show the boundaries between different types of long term behaviour in $K_1 - K_2$ space. The dotted lines represent the lines $K_i = H_{iT}$. The straight solid lines represent the lines given by equation (6) and the solid curve comes from making inequality (4) into an equality and rearranging to find K_2 in terms of K_1 . For this graph

we have $\beta_{11} = 0.1; \beta_{12} = 0.05; \alpha_1 = 0.5; b_1 = 1; \mu_1 = 1; \nu_1 = 0; \gamma_1 = 0; r_1 = 1; \beta_{22} = 0.25; \beta_{21} = 1;$
 $\alpha_2 = 3; b_2 = 1.5; \mu_2 = 1; \nu_2 = 0; \gamma_2 = 0; r_2 = 1.5;$

Figure 3: Graph to show the effect of changing vaccination rates on the long term behaviour of the system if we have infected coexistence when there is no vaccination in either species. In this case, the dotted lines represent the threshold vaccination rate for the two species when alone with the pathogen. The solid curve comes from making inequality (4) into an equality and rearranging to find ν_2 in terms of ν_1 . In this case the parameters are:

$\beta_{11} = 0.05; \beta_{12} = 0.03; \alpha_1 = 3; b_1 = 1; \mu_1 = 1; K_1 = 300; \gamma_1 = 0; r_1 = 1; \beta_{22} = 0.075; \beta_{21} = 0.02;$
 $\alpha_2 = 4; b_2 = 2; \mu_2 = 1; K_2 = 200; \gamma_2 = 0; r_2 = 2;$

Figure 4: Graph to show the effect of changing vaccination rates on the long term behaviour of the system if we have infected coexistence when there is no vaccination in either species if we have $H_{iT} > K_i$ for $i=1,2$. The solid curve comes from making inequality (4) into an equality and rearranging to find ν_2 in terms of ν_1 . In this case the parameters are:

$\beta_{11} = 0.05; \beta_{12} = 0.03; \alpha_1 = 3; b_1 = 1; \mu_1 = 1; K_1 = 80; \gamma_1 = 0; r_1 = 1; \beta_{22} = 0.075; \beta_{21} = 0.02;$
 $\alpha_2 = 4; b_2 = 2; \mu_2 = 1; K_2 = 80; \gamma_2 = 0; r_2 = 2;$

Figure 5: Graph to show the effect of changing vaccination rates on the long term behaviour of the system if species 1 is alone with the pathogen when there is no vaccination in either species. In this case the dotted line represents the threshold vaccination rate for species 1 when alone with the disease. The solid straight line represents inequality (5), made into an equality and rearranged to give ν_2 in terms of ν_1 . The solid curve comes from making inequality (4) into an equality and rearranging to find ν_2 in terms of ν_1 . In this case the parameters are:

$\beta_{11} = 0.05; \beta_{12} = 0.2; \alpha_1 = 0.5; b_1 = 1; \mu_1 = 1; K_1 = 1000; \gamma_1 = 0; r_1 = 0.75; \beta_{22} = 0.1; \beta_{21} = 0.3;$
 $\alpha_2 = 2; b_2 = 2; \mu_2 = 1; K_2 = 100; \gamma_2 = 0; r_2 = 0.5;$

Figure 6: Graph to show the effect of changing vaccination rates on the long term behaviour of the system if species 2 is alone with the pathogen when there is no vaccination in either species. This is found in the same way as figure 3. In this case the parameters are:

$\beta_{11} = 0.05; \beta_{12} = 0.01; \alpha_1 = 7; b_1 = 1; \mu_1 = 1; K_1 = 250; \gamma_1 = 0; r_1 = 0.75; \beta_{22} = 0.03; \beta_{21} = 0.02;$
 $\alpha_2 = 0.5; b_2 = 2; \mu_2 = 1; K_2 = 500; \gamma_2 = 0; r_2 = 2;$

Figure 7a and b: Graph to show the effect of changing vaccination rates on the long term behaviour of the system if there is contingency when there is no vaccination in either species. (b) is a close up a the region of parameter space close to the origin. In this case the dotted lines represent the threshold vaccination rates for each species when alone with the disease. The solid lines represent inequality (5), made into an equality for $i,j=1,2$ and rearranged to give v_2 in terms of v_1 in each case. In this case the parameters are:

$$\beta_{11} = 0.06; \beta_{12} = 0.125; \alpha_1 = 3.5; b_1 = 0.5; \mu_1 = 1; K_1 = 3000; \gamma_1 = 0; r_1 = 0.5; \beta_{22} = 0.05; \beta_{21} = 0.2; \\ \alpha_2 = 3; b_2 = 1; \mu_2 = 1; K_2 = 1500; \gamma_2 = 0; r_2 = 0.75;$$

Figure 8: Graph to show the effect of changing vaccination rates on the long term behaviour of the system if species 2 is alone with the pathogen when there is no vaccination in either species if we have $H_{1T} > K_1$ and $H_{2T} < K_2$. This is derived in the same way as figure 3. In this case the parameters are:

$$\beta_{11} = 0.05; \beta_{12} = 0.01; \alpha_1 = 7; b_1 = 1; \mu_1 = 1; K_1 = 150; \gamma_1 = 0; r_1 = 0.75; \beta_{22} = 0.03; \beta_{21} = 0.02; \\ \alpha_2 = 0.5; b_2 = 2; \mu_2 = 1; K_2 = 500; \gamma_2 = 0; r_2 = 2;$$

Figure 1

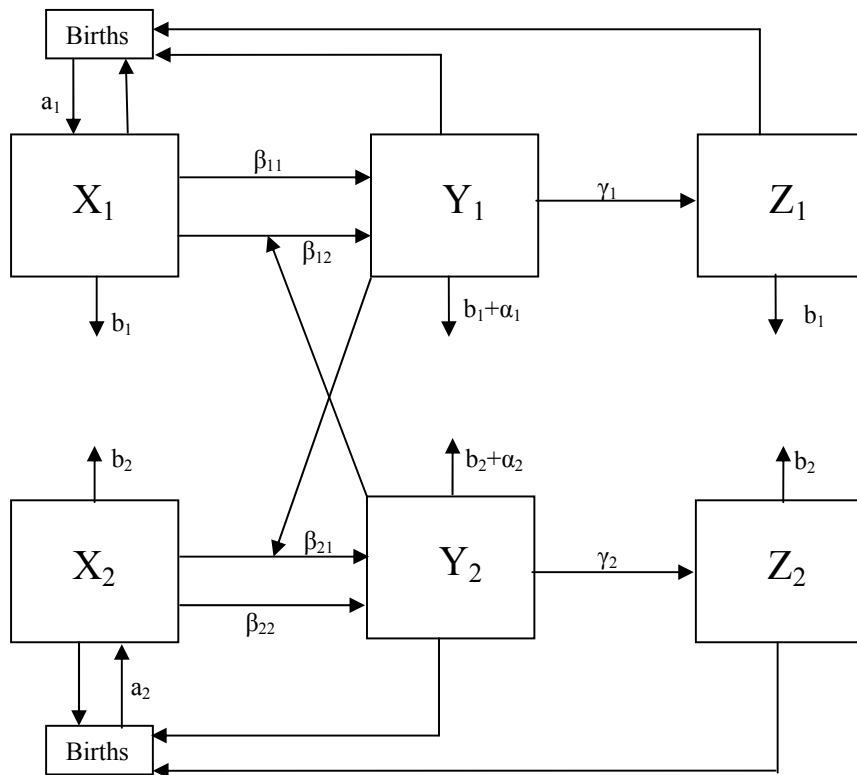

Figure 2

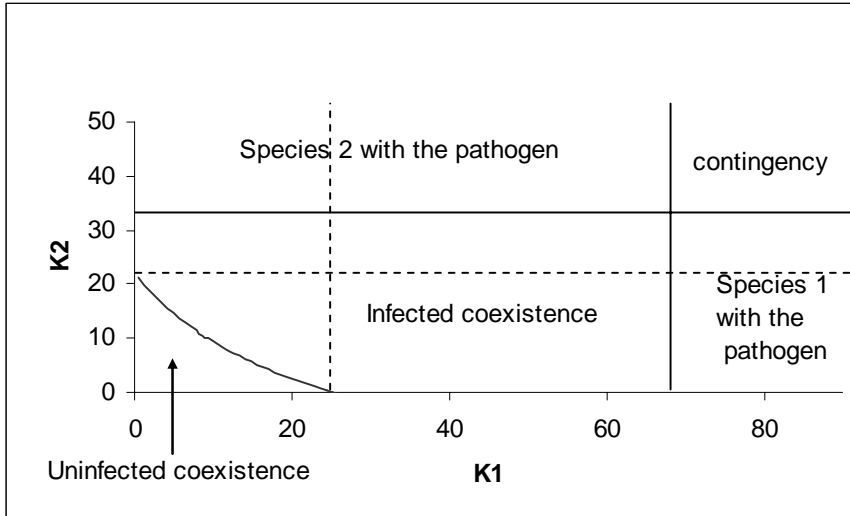

Figure 3

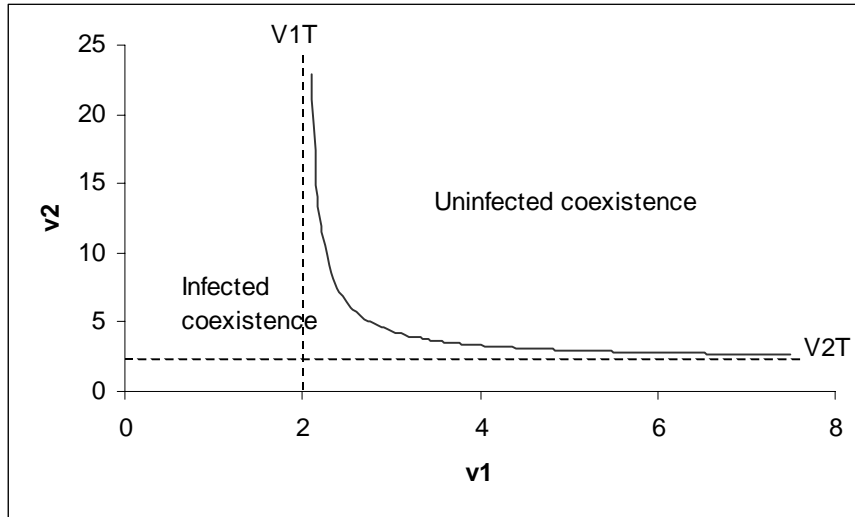

Figure 4

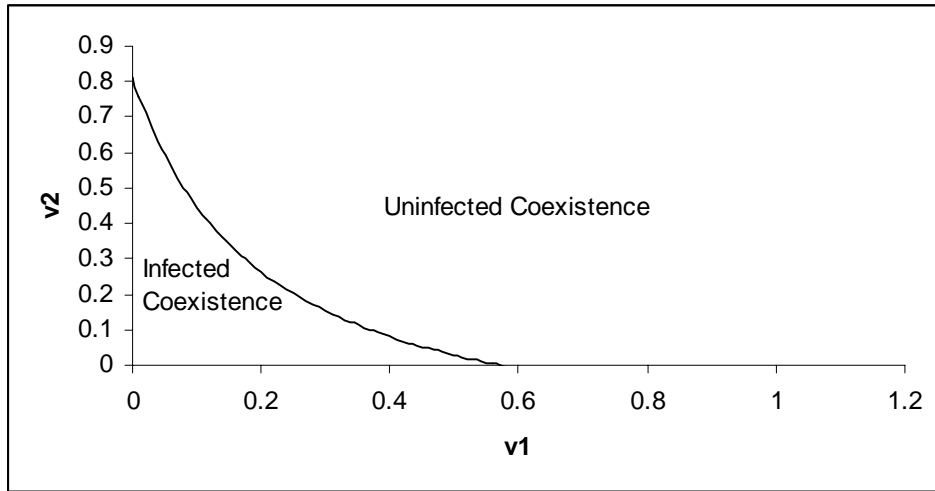

Figure 5

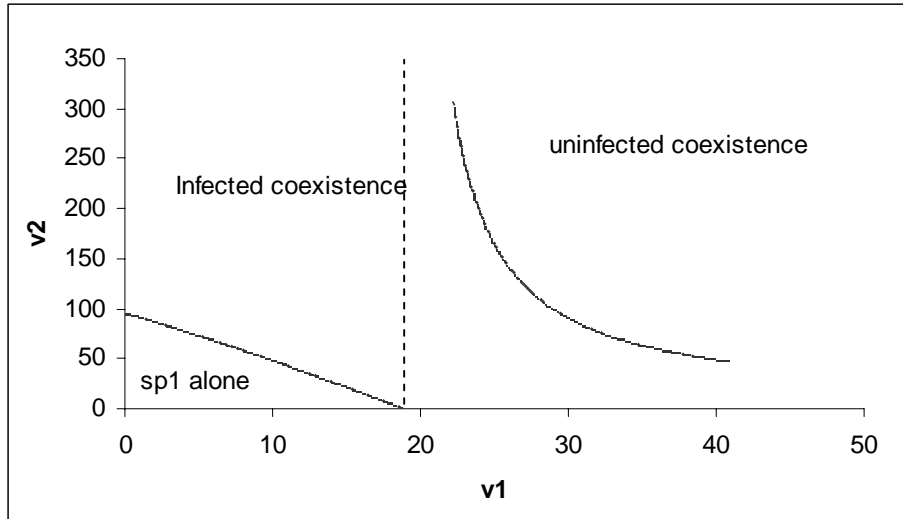

Figure 6

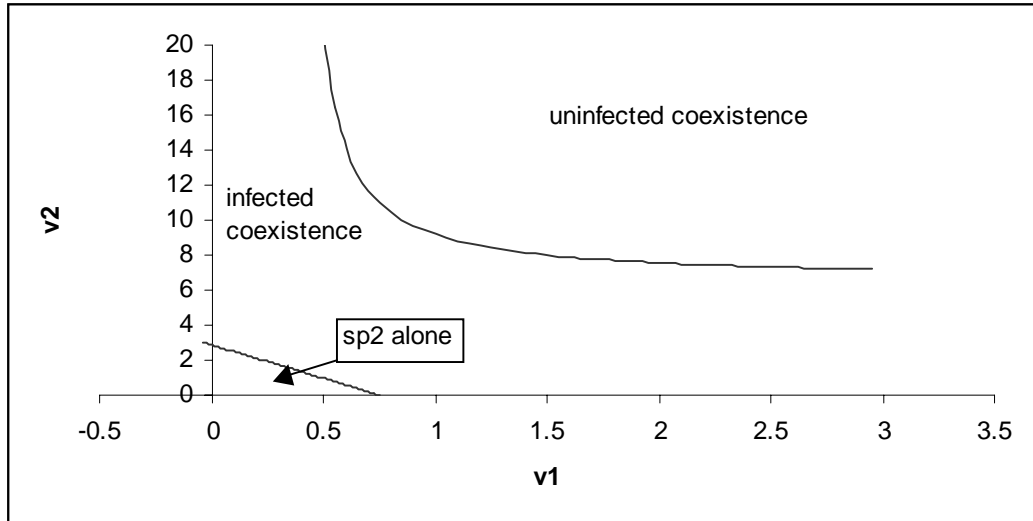

Figure 7a

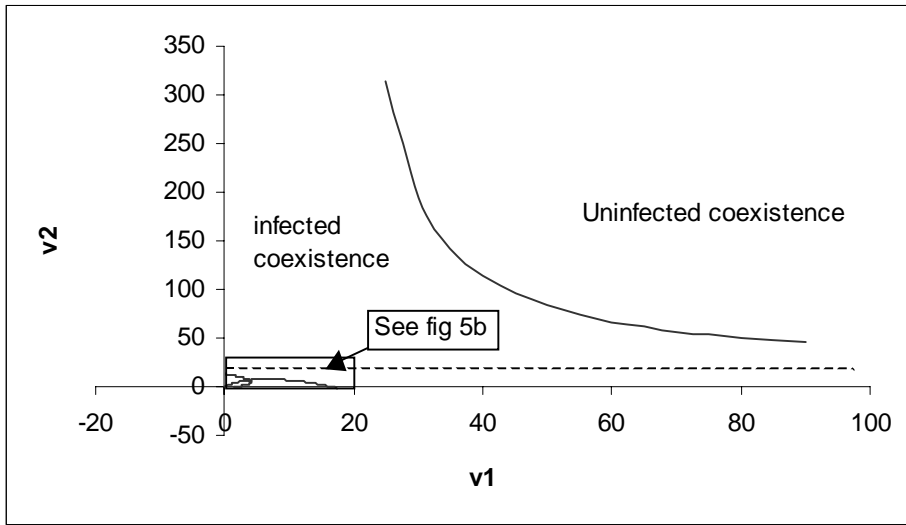

Figure 7b

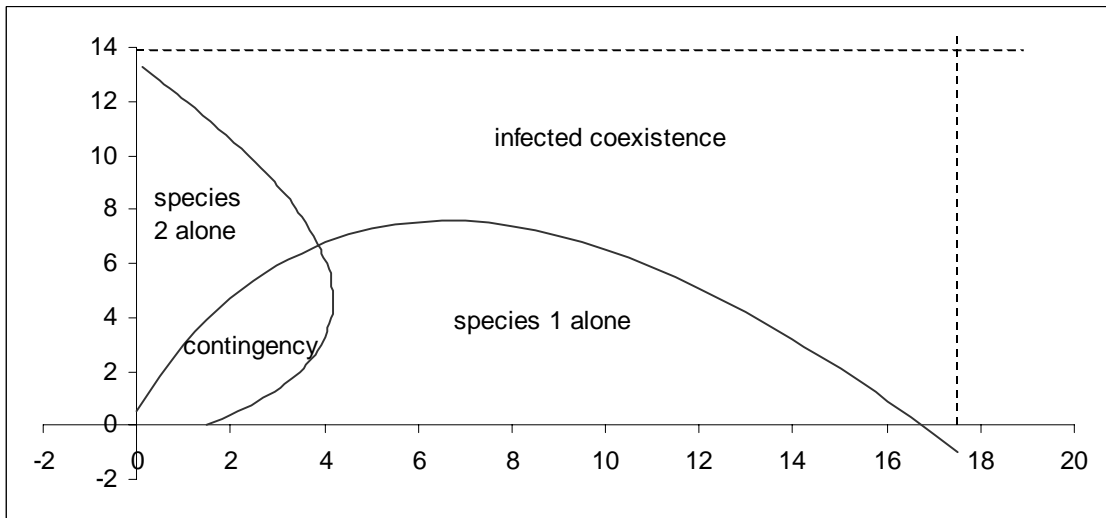

Figure 8

