

3562352700

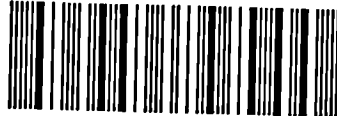

Thesis 1152

DETECTING THE MYTH: AN APPLICATION OF C. G. JUNG'S  
ANALYTICAL PSYCHOLOGY TO FILM ANALYSIS

LUKE JAMES HOCKLEY

Submitted for the degree of Doctor of Philosophy

University of Stirling  
Stirling  
Scotland

May 1988

4/89.

## Dedication

To my parents Ronald and Jennifer Hockley,  
who have always supported and encouraged me.  
Thanks for helping me to think freely.

ACKNOWLEDGEMENTS

I would like to thank Dr. John Izod and Mr. Richard Kilborn for their careful supervision of this thesis and for the many insightful comments which they have made.

To Gareth Evan Palmer. The music, the whisky, and the fighting were great, without them there could have been no thesis. Also to Jan, the best cook in "the known universe".

A special thanks to Eleanor Murrey who typed many of the initial drafts, and to all those who helped with the proof reading and advice, especially Father Andrew Campbell, O.S.B.

I also acknowledge the generous financial support of the British Academy, the Stirlingshire Educational Trust and the Sir Richard Stapley Educational Trust.

CONTENTS

	<u>Page</u>
ACKNOWLEDGEMENTS	(i)
ILLUSTRATIONS, TABLES AND DIAGRAMS	(iv)
ABSTRACT	(v)
INTRODUCTION	1
PART ONE : AN INTRODUCTION TO THE ANALYTICAL PSYCHOLOGY OF C. G. JUNG, WITH REFERENCE TO ITS APPLICATION IN THE ANALYSIS OF FILMS	10
Chapter One:       An Investigation Into C. G. Jung's Psychology of Consciousness	11
Chapter Two:       C. G. Jung's Psychology of the Unconscious and Film Theory	52
Chapter Three: <u>Tightrope</u>	84
PART TWO : THE MODEL: A THEORETICAL SYSTEM FOR THE APPLICATION OF C. G. JUNG'S ANALYTICAL PSYCHOLOGY TO FILM ANALYSIS	104
Chapter Four:       The Origins of the Archetype	105
Chapter Five: <u>Blade Runner</u>	138
Chapter Six:        The Symbolic Search	159
Chapter Seven:     Individuation and the Detective	184
PART THREE : A FINAL CASE STUDY: <u>TRANCERS</u> THE INDIVIDUATION OF JACK DETH	226
Chapter Eight:     Archetype's Image and Archetypal Pattern	227
Chapter Nine:      Archetype's Image and Mythologem	252
Chapter Ten:       Mythology and Mythologem	274
Chapter Eleven:    Archetypal Pattern and Mythology	294
Chapter Twelve:   The Process of Individuation	314
CONCLUSION	329

ILLUSTRATIONS, TABLES AND DIAGRAMS

	<u>Page</u>
The Psyche: The Ectopsychic System	40
The Psyche: The Ectopsychic and Endopsychic Systems	47
The Psyche: The Ectopsychic, Endopsychic Systems and the Objective Psyche	55
Yin and Yang	61
The Uroboros	72
Kalachakra Mandala	79
The Conventional Method for Classification of Archetypes	123
An Alternative Method for Classification of Archetypes	124
A Model of Stein's Method of Archetypal Classification	125
Analytic Model in Skeleton	129
Analytical Model and its Central Guiding Questions	136
Schematic Diagram of the Individuation Process	193
A Table of Anima Images	202
A Diagram Illustrating the Detective's Psyche	214
The Phases of Individuation, A Revised Schematic/Diagram	216
Ego to Self	219
An Infilled Cross Design	221
The Hero's Quest Motif	257
The Separation of Sky and Earth in the Egyptian Cosmology	260
People Shape the World in the Polynesian Creation Myth	261
A Plan of the City of Atlantis	298
The City Centre of Paris, France	300
The City Centre of Palmanova, Italy	301
Finnish Stone Maze, 19th Century British Turf Maze, Maze in Tiles at Chartres Cathedral	309
A Table of Some of the Opposition in <u>Trancers</u> as they relate to the concept of <u>Enantiodromia</u>	316

ABSTRACT

This thesis applies the analytical psychology of C. G. Jung to the study of films. The thesis is in three parts. Part One forms an introduction to the theory of analytical psychology and makes the initial links to film theory. Part Two involves the development of a model for systematically applying the theory and Part Three is a detailed analysis of one film.

Part One

In Chapter One Jung's theories about conscious behaviour are explored, some initial points of contact are made with film analysis, and a variety of films are used to illustrate the relevance of the theory. Chapter Two finds areas of correspondance between Jung's theories of the unconscious and film theory. This is a bridging of what had previously been regarded as separate critical traditions. Chapter Three is a detailed analysis of Tightrope (Dir. R. Tuggle, Warner Brothers, 1984) which demonstrates the applicability of analytical psychology in the analysis of films.

Part Two

Chapter Four presents more theory about the nature of archetypes, and from this a model is derived. This model enables the central tenets of analytical psychology to be used for the analysis of films. This is demonstrated in Chapter Five which is an analysis of the detective film Blade Runner (Dir. R. Scott, Columbia, 1982). Chapter Six explores the function of the symbol in film, especially how it relates to the development of the narrative and to the psychological growth of the film's central characters. Chapter Seven is the last of the theoretical chapters and indicates how the individuation process can be applied to films. The figures of the shadow and the femme fatale are regarded as having a particular generic and cultural importance.

Part Three

The remaining chapters are a detailed examination of Trancers (Dir. C. Band, Lexyen Productions, 1984), in which the model established in Chapter Four is used to facilitate the analysis of the film. This reveals that beneath the visual and narrative surface of the film there exists a series of mythological and psychological structures. Ultimately the film is regarded as an expression of collective latent unconscious psychological needs.

1.

INTRODUCTION



INTRODUCTION

Part One of this thesis is an introduction to the analytical psychology of C. G. Jung and a demonstration of its applicability to film analysis. Part Two is the extraction from this of a model for applying the psychological theory, a critique and development of Jung's theories and a further more detailed application of them in film analysis. Finally Part Three is the extensive analysis of one film which demonstrates the application of analytical psychology.

In contrast to the psychological theories of Sigmund Freud, Jung has found little appeal and, perhaps, even less academic acceptance. There are various reasons for this imbalance, however the volume of Jung's work (there are currently over twenty volumes in the Collected Works) and the impenetrability of his writing are two contributory factors. It therefore comes as little surprise to discover that analytical psychology has not been extensively applied to the analysis of films, and the notable exceptions to this exist mainly in article form, for example Roth's 'Raiders of the Lost Archetype: the Quest and the Shadow'.<sup>1</sup> The problem with articles is that they do not provide the opportunity for a detailed discussion of their subject matter, and consequently the applicability of Jung's theories to the analysis of films remains largely unproven.

The one book which does extensively apply Jung's insights is Clarke Branson's Howard Hawkes: A Jungian Study.<sup>2</sup> This recent work was published in 1987, although at the time of writing it is unavailable in Britain. The book provides a very useful reference point as it includes a Jungian analysis of all

---

<sup>1</sup> Roth, L., 'Raiders of the Lost Archetype: the Quest and the Shadow', Studies in the Humanities, Vol.10, June (1983).

<sup>2</sup> Branson, C., Howard Hawkes: A Jungian Study, (Los Angeles, 1987).

Hawkes' films. While such an undertaking is to be warmly welcomed, the book does possess limitations.

First it deals primarily with the psychology of the auteur, that is it treats the films of Hawkes as ways of analysing his psyche. Depending on what it is you want to prove, this may be a valid way of approaching the films, but it leaves unanswered the question of if, and how, films function psychologically, preferring rather to see the films as reflections of Hawkes' psyche. The second reservation about this book is that Branson applies the theory of analytical psychology in a fairly simplistic and non-systematic way.<sup>1</sup> While the central tenets of Jungian theory are observed, little attempt is made to develop either the theory of film or psychology, and the resulting analysis can seem weak and unsubstantial.

This problem is not limited to Branson, and the dangers of this approach can be seen in Andrew Gorden's analysis of the film Star Wars (Dir. G. Lucas, Twentieth Century Fox, 1977). In this apparently Jungian based analysis of the film's psychological and mythological themes Gorden notes,

'As the servant of the Emperor, Vader is a feminized father, and Luke fears he will become just like his father. Already both have been symbolically castrated through the loss of their right hands. Giving in to the Emperor, being seduced by "the Dark Side", represents for Luke submitting to all the forces he fears inside himself, including the desire to make love to and kill his father'.<sup>1</sup>

This curious mixture of Freudian, Adlerian and Jungian psychologies misrepresents all of them, and the reason for this is that Gorden lacks a system for applying psychology in analysis. As a result his interpretive claims are distinctly wayward. If a clear Jungian method of mythological amplification had been adopted, then the inadequacies of regarding the Emperor

---

<sup>1</sup> Gorden, A., 'Return of the Jedi: the End of the Myth', Film Criticism, Vol. 8(2), Winter, 1984): p51

as the dark side of the force, and Vader as a 'feminized father' would have been revealed and avoided.

Now that the need for a system for applying analytical psychology is evident, any pronouncements which Jung had to make about film would carry particular weight. Unfortunately Jung wrote very little about the psychological analysis and attributes of films, although he did feel that analytical psychology was well suited to the psychological analysis of 'artistic' products. He frequently wrote about literature and art,<sup>II,III</sup> and he also found parallels between the psychological study of art and the analysis of dream imagery. In the following passage he is writing specifically about the psychological analysis of literature, but he could equally well be referring to any creative product, for example films.

'It is obvious enough that psychology, being a study of psychic processes, can be brought to bear on the study of literature, for the human psyche is the womb of all arts and sciences... Psychology and aesthetics will always have to turn to one another for help, and the one will not invalidate the other.<sup>1</sup>

When Jung did comment on film he was well disposed towards it, and saw it as a highly valuable medium which represented psychological characteristics. Jung saw film like all media as an essentially psychological event, but he felt that films were particularly suited to give expression to the objective psyche,<sup>IV</sup> or collective unconscious.

'The movies are far more efficient than the theatre; they are less restricted, they are able to produce amazing symbols to show the collective unconscious, since their methods of presentation are so unlimited'.<sup>2</sup>

The above quote is from the seminars on dream analysis that Jung gave in 1928. If he felt the movies at that time to possess unlimited methods of

---

<sup>1</sup> C. W. 15: 133-135

<sup>2</sup> Jung, C. G., Seminars on Dream Analysis, edited McGuire, W., (London, 1984): p12

presentation then he must have been delighted at the way in which cinema technology was to help in creating increasingly imaginary and remote filmic worlds. It is no accident that this passage occurs during a seminar on dream analysis for there are many points of contact between the analysis of dreams and the analysis of films. This is not in any way meant to suggest that films are dreams,<sup>V</sup> only that similar procedures can be adopted for analysing both media.

While Jung wrote very little about the psychological analysis or properties of films (there are only a handful of references in the twenty volumes of the Collected Works) he did make some more general comments about how he thought analytical psychology should develop. He felt that it should leave the confines of the consulting room and affect the everyday lives of people and the development of cultures. In 1929 he wrote a paper called The Problems of Modern Psychotherapy and in it he noted that,

'...analytical psychology has burst the bonds which till then had bound it to the consulting-room of the doctor. It goes beyond itself to fill the hiatus that has hitherto put Western civilization at a psychic disadvantage as compared with the civilizations of the East... at a higher cultural level we must forgo compulsion and turn to self-development. For this we must have a way, a method, which, as I said, has so far has been lacking. It seems to me that the findings and experiences of analytical psychology can at least provide a foundation...'<sup>1</sup>

Perhaps initially it is difficult to see how analytical psychology can be applied to the analysis of films. As a result of this, it is important to gradually make connections between the two fields, so that a relationship is established which is mutually beneficial. However the guidelines mentioned by Jung in the previous passage should also be followed, so that while film theory and analytical psychology are brought into a relationship

---

<sup>1</sup> C. W. 16: 174

with each other it is the 'experience of analytical psychology' which provides the foundation.

In response to these needs, the first chapter of the thesis provides a basic introduction to analytical psychology's theory of consciousness, and the first tentative links to film analysis are established. This theory is also placed in the context of twentieth century psychology, so that the specific emphases of analytical psychology become apparent. This chapter also contains a brief biography of Jung which identifies some of his personal preoccupations and life themes, because these were factors which intimately affected the development of analytical psychology.

The second chapter extends the presentation of analytical psychology to include its theories of how the unconscious functions. Constant reference is made to film theory, although not to practical film analysis, so that further connections are made between the two subjects. So in these first two chapters the applicability of Jungian theory to the study of film is demonstrated at both practical and theoretical levels.

Part One concludes with an application of the theory established in the previous two chapters to the detective film, Tightrope (Dir. R. Tuggle, Warner Brothers, 1984). The brief examination serves two purposes. First it indicates that analytical psychology can be effectively used in film analysis, and secondly it reveals the need of a more systematic approach for the application of Jung's theories.

Having identified the need for a systematic approach, the focus in Chapter Four becomes more specific. There is a detailed presentation of archetypal theory and, from this theoretical base, a model is presented which assists in the application of analytical psychology to film analysis. In the fifth

chapter the model is used to assist in the Jungian interpretation of a film, which shows the value of the model in revealing concealed archetypal, mythic and symbolic structures. The film chosen for this is Blade Runner (Dir. R. Scott, Columbia, 1982).

Part Two ends with two theoretical chapters which are derived from the model and which provide an in-depth understanding of its psychological basis. They also continue to explore the relationship of analytical psychology and film theory. The first of these chapters deals with symbols, their function and occurrence in films. The second is concerned with Jung's theory of individuation, and as this is the factor which unites analytical psychology, it is of prime importance to the theoretical model. It also regards individuation as a process which occurs at both individual and collective levels.

The final section of the thesis, Part Three, is an extensive application of the model. It consists of a detailed analysis of one film, Trancers (Dir. R. Band, Lexyen Productions, 1984) and during this analysis the theory of the previous chapters is applied. It demonstrates that there exist in this film concealed levels of cultural expression which are not revealed by using conventional film analysis techniques, and ultimately this film is regarded as a manifestation of collective, although concealed, unconscious needs. These latent needs can only be revealed with recourse to analytical psychology as this exposes these shared unconscious structures.

In the film analyses there is an emphasis on detective films because they provide particularly rich examples of archetypal and mythological material. The further reasons for their selection will become apparent as the thesis progresses, and without wanting to prejudice the later development of the argument, it is interesting to note that Jung was also interested

in the detective story and found it ideally suited to psychological analysis.

'In general, it is the non-psychological novel that offers the richest opportunities for psychological elucidation. Here the author, having no intentions of this sort, does not show his characters in a psychological light and thus leaves room for analysis and interpretation, or even invites it by his unprejudiced mode of presentation. Good examples of such novels are... that most popular article of literary mass-production, the detective story...'<sup>1</sup>

Trancers is emphatically a 'non-psychological' film in that it is a low budget film produced for the home video market, although it did also go on general release. As such it is a produce of mass culture, and a psychological analysis of it provides interesting insights into the latent cultural psychology.

From the preceding remarks it can be seen that the aim of this thesis is to explore the possibilities of applying analytical psychology in film analysis, and to discover if this reveals anything about films that might be missed by conventional film analysis techniques. Of course this application of analytical psychology to films provides only one perspective on the film text, but for film analysis it is a new point of view. The approach does not claim to provide all the answers to the problems of film analysis, and it would be unwise to assert that it is better or worse than many other methods for analysing films. What can be said is that it is a new and different method, and it provides an additional framework in which to critique films.

---

<sup>1</sup> C. W. 15: 137

INTRODUCTION NOTES

- I. c.f. Branson, p207-219. The Jungian analysis of Gentlemen Prefer Blondes, (Dir. H. Hawkes, Twentieth Century Fox, 1953) illustrates many of the shortcomings inherent in Branson's approach.
- II. c.f. C. W. 15 (The Spirit in Man, Art and Literature).
- III. Extracts and references to the Collected Works of C. G. Jung, edited Read, H., Fordham, M., and Adler, G., translated Hull, R., will take the following format. First the prefix C. W., then the volume number followed by the paragraph number, e.g. C. W. 10: 193. Unless otherwise stated the volume cited from will be the latest revised edition available.
- IV. The term 'objective psyche' is used by Jung in his later writings as a replacement for the more popular conception of the 'collective unconscious'.
- V. One of the earliest film theoreticians to find links between the psyche and films was Munsterberg. As early as 1916 he found a connection between the needs of the soul (which has the same Etymological root as psyche) and films. 'In both cases the act which in the ordinary theatre would go on in our mind alone is here in the photography projected into the pictures themselves. It is as if reality has lost its own continuous connection and become shaped by the demands of our soul.' Munsterberg, H., The Film a Psychological Study: the silent photoplay in 1916, (New York, 1970), p41.

It is also interesting that the psychologist James Hillman describes dreams and analysis as the 'work of soul making'. c.f. Hillman, J., The Dream and the Underworld, (New York, 1979), p137-138.



PART ONE

AN INTRODUCTION TO THE ANALYTICAL PSYCHOLOGY OF C. G. JUNG,  
WITH REFERENCE TO ITS APPLICATION IN THE ANALYSIS OF FILMS

Chapter One

An Investigation Into C. G. Jung's  
Psychology of Consciousness

## INTRODUCTION

This chapter is concerned with introducing the analytical psychology of C. G. Jung. It aims to examine Jung's psychology of consciousness and regards this as an integral part of his theory of personality types. There are three principal sections to this chapter. The first section provides a psychological context for Jung's theories and in this process three major theories are discussed, these are: behaviourism, psychodynamic theories, humanism. The second section provides a personal context for Jung's psychology and consists of a brief biographical background against which to place his theories. The third and final section which is concerned with presenting Jung's theory of consciousness, is subdivided into two sections. The first of these is an account of the functions of consciousness (the ectopsychic system) and the second is an exploration of the more concealed levels of conscious functioning (the endopsychic system). Throughout this chapter reference is made to a variety of films and the intention is to indicate the general applicability of Jungian psychology for discussing the general psychological attributes of film, and in so doing to form an association between analytical psychology and film theory. In the next chapter the presentation of Jungian theory is extended to include Jung's psychology of the unconscious, and the applicability of this psychology to film theory is further explored.

Before embarking on a detailed introduction to C. G. Jung's analytical psychology, it is important to briefly examine some of the other mainstream twentieth century psychological theories. This will situate analytical psychology in its cultural/psychological context. Within twentieth century psychological thought there are three principal categories, and these are: behaviouristic, psychodynamic and humanistic.

PSYCHOLOGICAL CONTEXT OF ANALYTICAL PSYCHOLOGY: BEHAVIOURISM

Perhaps the simplest of these three theories is the behaviouristic. This school of psychology studies only what it thinks is unambiguously observable with the additional intention of measuring whatever behaviour is observed. (In Russia this school was closely identified with Ivan Pavlov's work on conditioned reflexes, while in America it was J. B. Watson who launched the behaviouristic movement in 1913. Two men who gained much respect in this field were Clark Hull and B. F. Skinner). Underpinning the behaviourist school of thought is the idea that all human behaviour can ultimately be reduced to the relationship between stimulus and response, and this is the so called 'S. R. psychology'. The consequence of this position is that behaviour is seen as the result of stimuli (S) which are active in the environment, both present and past, and it is these stimuli which form the response (R). As Skinner has commented,

'The important fact is that such contingencies, social or nonsocial, involve nothing more than stimuli or responses; THEY DO NOT INVOLVE MEDIATING PROCESSES. We can not fill the gap between behaviour and the environment of which it is a function through introspection because, to put the matter in crude physiological terms, we do not have nerves going to the right places.'<sup>1</sup>

A serious shortcoming of this theory is that it omits the potential for both introspection and consciousness.<sup>I</sup> To be more accurate, human consciousness is reduced to the now infamous 'black box'. This theory regards the S. R. paradigm as a closed system and within this system it tries to make connections between S. and R., that is the input and the output. The way in which this is achieved is by setting up a series of parameters that link the S. and R., the study of which is called axiomatics.<sup>II</sup> O'Neil has commented on the S. R. paradigm and notes that,

---

<sup>1</sup> Skinner, B. F., Reflections on Behaviourism and Society, (New Jersey, 1978): p50-51

'The essence of behaviour is ultimately reducible to S. and R. like the popular image of the near archetypal white rat daintily pressing the food bar in the operant conditioning chamber because such responses are rewarded by appetitive stimuli which increase the probability that the bar pressing response will recur.'<sup>1</sup>

It is an inevitable consequence of the behaviourist argument that the existence of free will is ruled out, and because of this a huge body of psychological and philosophical thought finds it necessary to reject this approach. Even so others feel that it may be retained as an investigative methodology. For while the work of the behaviourist movement has been criticised as, 'an elegant but superficial pursuit of trivial problems couched in arid language and too artificial to have relevance for "real life" problems of either animals or people',<sup>2</sup> it has contributed much to mainstream psychology through factual physiological information, new concepts or models and new methods of investigation.

### PSYCHODYNAMIC THEORIES

In some ways the psychodynamic theories are parallel to those of behaviourism. (The term psychodynamic has a variety of meanings, in this thesis the term is being used to describe and encompass all 'theories which represent symptomatic behaviour as determined by an interplay of forces within the mind of an individual subject without involving awareness. This is exemplified by Freudian psychoanalytic theory...'<sup>3</sup> As O'Neil has noted<sup>III</sup> the psychodynamic theories can be seen as a subset of behaviourist theories, and all that is required to facilitate this is the introduction of another term into the S. R. equation. This term is represented by the letter 'O'

---

<sup>1</sup> O'Neil, T. R., The Individuated Hobbit, (London, 1979): p7

<sup>2</sup> Fontana Dictionary of Modern Thought, (London, 1983): p57

<sup>3</sup> Fontana Dictionary of Modern Thought: p507

which stands for the 'organismic variable'. Thus the equation now stands - S. O. R., this means that a stimulus is given to an organism and this results in a response from the organism. This response may vary from organism to organism, and hence the use of the term 'organismic variable'.

An example of this S. O. R. model in operation might be the Rorschach's, or ink blot, test. Here the test is given (S) to the human (O) who produces a response (R), as this response varies from subject to subject the change is attributed to a variable in the organism (O). This variable may then be named. Thus it can be seen that the S. R. paradigm of pure, or formal behaviourism can be extended to embrace psychodynamic theories.

In one sense it is slightly misleading to think of psychodynamic theories as encompassing behaviourism, for the earliest of the psychodynamic theories pre-dates behaviourism's formal birth. Also the S. O. R. model was not presented until 1926 some 25 years after Freud's The Psychopathology of Everyday Life. However it seems helpful to impose this S. O. R. model in order to clarify what are fairly difficult concepts.

Within the psychodynamic model O'Neil comments that, 'a man's behaviour is the product of the dynamic interaction of internal organismic forces - the outcome of a battle of constructs. These "psychodynamics" result in the unique dimensions of personality'.<sup>1</sup> It was Freud who first noted a variety of clinical symptoms which had no apparent medical origin and he called these 'psychoneuroses proper'. In doing this he was going against the mainstream of psychological and medical thought, eventually distancing himself even further from the medical establishment by claiming that these

---

<sup>1</sup> O'Neil: p9

psychoneuroses proper, were the result of the now well known Oedipal situation. In this situation the child is sexually attracted to the parent of the opposite sex, and the inability to deal with this impossible situation may result in neuroses in later adult life. To place this hypothesis within the S. O. R. model requires once more a slight adjustment to the equation. 'S' now represents the crisis in adult life, 'R' represents the neurotic symptoms and 'O' is the organism. The algebraic result is thus  $S(O)R^{IV}$  or, a certain set of environmental stimuli (the Oedipal situation), mediated by some unknown variables seems to result in a neurosis.

Determining what (O) is, is very difficult. However Freud gradually managed to build up a series of theoretical constructs. Two concepts, which are central to psychodynamic theory, he called consciousness and unconsciousness, and he assumed these to be theoretical levels of the mind. The concepts of id, ego and superego are other theoretical constructs which again provided Freud with a framework for discussing human psychology. For him the ego is the controlling centre of the personality and it is concerned with facing up to demands of the real world, dealing with both impulses from the id and requirements of the superego. The id acts to curtail pain and amplify pleasure, the so called 'pleasure principle', by giving free rein to primitive impulses and as such it conflicts with the 'reality principle' of the ego and the demands of the superego. The superego is the moral part of the personality which strives for perfection rather than pleasure and is an assimilation of environmental moral values.

There seem to be two central concepts in Freudian theory and both of these reveal the way in which it is a subset of behaviourist theories.

'(1) Man is essentially hedonistic, motivated by the 'pleasure principle'; even his most noble works may be no more than sublimated release of sexual energy in a socially acceptable activity; and (2) man's behaviour is determined by his instinctive drives and the ways in which these are directed and apportioned in early childhood.'<sup>1</sup>

There are two points of similarity between behaviourism and Freudian psychodynamic theory. First, the 'pleasure principle' is like the law of affect which states that if an action is pleasurable it is likely to be repeated, (as in the white rat pressing the food bar). Secondly, there is the concept of determinism which means that all behaviour is learnt and all responses are the result of triggering signals in the environment. Of course the difference is that the psychodynamic theorists are willing to employ the construct of the organismic variable (O) to explain behaviour which classical behaviourists are not.

#### A Filmic Example of S. R. and S. O. R. Responses

One of the functions of this thesis is to make connections between psychology and film theory, or more explicitly, between analytical psychology and films. Even at this early stage in the argument it is useful to begin this process of connecting up between the psychology and its application. The film Terminator, (Dir. J. Cameron, Orion, 1984) provides a good, if somewhat extreme film example of both the S. R. and S. O. R. models in operation. To some extent all robot films can be regarded as explicit, although exaggerated, examples of the behaviourist paradigm, but the Terminator is a particularly good example as it does incorporate both S. R. and S. O. R. models. It also displays the terminator's decision-making and responding processes in a particularly visual way.

---

<sup>1</sup> O'Neil: p11



The film features Arnold Schwarzenegger as a cybernetic organism robot which has been sent back from the future to 1984. His mission is quite simply to kill Sarah Conner and in an attempt to achieve this and discover her address, he goes to the telephone book. Unfortunately, there is more than one Sarah Conner so he tears out the page with all the listed Sarah Conners printed on it. His response to the stimulus name Sarah Conner is to kill the person possessing that name, so he proceeds to kill in telephone book order, all the Sarah Conners. The terminator makes no attempt to question any of his victims, he has no capacity for consciousness, no creativity, no introspection, he just has an uncontrolled killing response to the Sarah Conner stimulus. Later in the film there is an even clearer example of the S. O. R. model in operation. The terminator is repairing itself in a hotel bedroom when it hears a knock on the door. This stimulus causes a table of possible responses to flash up in the computer brain and these are superimposed onto the screen.

'Yes    No  
 Or what  
 Go away  
 Please come back later  
 Fuck you ars hole'.

(Terminator)

The computer brain, which in this example is the organismic variable, selects the last of these as the most suitable response to the stimulus and accordingly the terminator speaks the line. Clearly the S. O. R. model has its uses, but as its application in this film indicates, it is also severely limited. It is not intended to suggest that just because the film is simplistic so too the S. R. and S. O. R. models must also be simplistic. Rather the film represents a Reductio ad absurdum of these models and in so doing acts as an illustration of the tendency within these positions to over emphasise the mechanical and rationalistic aspects of human psychology.

HUMANISTIC THEORIES

The third and final of the three psychological theories is the humanistic theory, which recently seems to have gained popularity, and perhaps the reason for this is that the Freudian/Behaviouristic view of human nature seems both somewhat pessimistic and deterministic. One of the key founders of humanistic psychology is Abraham Maslow whose aim was to make the subject of psychology applicable to the everyday lives of ordinary people. Consequently humanism is highly critical of any branch of psychology which may seem dehumanising because of its interest in statistics on white rats! It is also interesting to note that two of humanism's central tenets are in direct contradiction to Freudian and Behaviouristic schools and theories:

'(1) Motivation, we are not solely the result of reinforcement of innate drives - we are being pulled upward to a final goal not just pushed rudely by our past. (2) Since not all behaviour is directed by reinforcement or early toilet training or whatever, then the concept of free will can exist. We are to some extent the captains of our own souls.'<sup>1</sup>

The concept of 'motivation' is generally one of self fulfilment, and this is termed by Maslow and Rogers 'self-actualisation'. This term represents the human potential of achieving stability and stasis in life. Self actualised people are able to accept their own peculiarities and accept others without prejudice or an irrational judgementalism, they are not so likely to twist 'life experiences' just to flatter their own egos. However they are not 'perfect' people precisely because they are aware of their own independence and are therefore self-reliant. Most people never achieve the desired state of self-actualisation, being drawn, or pulled, away from the path of self-actualisation; and the degree to which one is distanced from

---

<sup>1</sup> O'Neil: p12

this path is termed incongruence or alienation. To a certain extent there is a parallel between incongruence and C. G. Jung's concept of the 'complex', because for Jung a complex is regarded as a frustration of the individuation process, and this is his equivalent to self-actualisation.

#### JUNG: A BRIEF BIOGRAPHICAL/PERSONAL CONTEXT

Before embarking on the theory of C. G. Jung's analytical psychology, which could be classified as a psychodynamic theory with strong humanist overtones, it is important to briefly mention a few of Jung's biographical details, as this provides a personal context to the development of his theories.

Carl Gustav Jung was born on the 25th July 1875 at Kesswil in Switzerland. At this time the traditional protestant values of personal integrity, hard work, honesty and social progress dominated the Swiss social and cultural life and, as Jung's father was a protestant minister, he was brought up particularly immersed in these values. Jung came from a comparatively small family which may have been due to a breakdown of his parent's marriage, and Carl was only their second son, his elder brother having died at birth. He had only one sister, Johanna Gertrude, who was nine years younger than himself.

Of Jung's early years little is known. His father was moved from Kesswil to a new parish at Laufen and at the age of eighty-three Jung still spoke of being able to remember the vicarage, 'I recall the vicarage, the garden, the laundry house, the church, the castle, the Falls, the small castle of Wörth, and the sexton's farm.'<sup>1</sup> In his autobiography, Memories, Dreams,

---

<sup>1</sup> Jung, C. G., Memories, Dreams, Reflections, (London, 1963): p21

Reflections, he also writes about being able to remember some sense impressions which belong to his time as a baby, and it is typical of Jung that he recalls sensations not thoughts or people.

'I am lying in a pram, in the shadow of a tree. It is a fine, warm summer day, the sky blue, and golden sunlight darting through green leaves. The hood of the pram has been left up. I have just awakened to the glorious beauty of the day, and have a sense of indescribable well-being.'<sup>1</sup>

Despite this 'sense of indescribable well being' there is a tension between Jung's mother and father and for a while this resulted in their temporary separation. At the same time Jung contracted eczema and in later life concluded, 'My illness, in 1878, must have been connected with a temporary separation of my parents'.<sup>2</sup>

At the age of six Jung went to school, again little is known of this period but apparently he was vigorous in his religious devotions<sup>V</sup> which perhaps indicates an intuitive awareness of the importance of ritual. He also ritualistically carried an oval stone, collected from the Rhine, which he painted in two different colours and only later in life did he discover that in some cultures this is a symbol of the soul. Perhaps the most important event while he was at school was that he was sexually assaulted, but it is difficult to ascertain the details because the incident does not occur in Memories, Dreams, Reflections, however it is mentioned in one of Jung's letters to Sigmund Freud,

'Actually - and I confess this to you with a struggle - I have a boundless admiration for you both as a man and a researcher, and I bear you no conscious grudge. So the self-preservation

---

<sup>1</sup> Jung, Memories, Dreams, Reflections: p21

<sup>2</sup> Jung, Memories, Dreams, Reflections: p23

complex does not come from there; it is rather that my veneration for you has something of the character of a "religious" crush. Though it does really not bother me, I still feel it is disgusting and ridiculous because of its undeniable erotic undertone. This abominable feeling comes from the fact that as a boy I was the victim of a sexual assault by a man I once worshipped.<sup>1</sup>

The exact date of the assault is unknown and whether the assault affected Jung and Freud's friendship is also uncertain, but the incident must have been important for Jung to mention it twenty years later.

At the age of eleven Jung entered the Basel Gymnasium, to him this proved to be a splendid but foreign world, and here he attended classes in divinity, mathematics, languages and art. At all these subjects he was a failure and most masters thought of him as stupid, and it was during this time that Jung developed what he terms his personalities one and two. Bearing in mind Jung's breakdown in 1913, some commentators have suggested that this forming of two personalities may have been the beginnings of schizophrenia. However Jung has always denied this, and he describes the two personalities in the following manner; number one was:

'... the son of my parents, who went to school and was less intelligent, attentive, hard-working, decent, and clean than many other boys. The other was grown up - old, in fact - sceptical, mistrustful, remote from the world of men, but close to nature, the earth, the sun, the moon, the weather, all living creatures... and suddenly overpowered by a vision of the whole cosmos, so that he could only marvel and admire, forgetful of himself. Here lived the "the other," who knew God as a hidden, personal, and at the same time suprapersonal secret.'<sup>2</sup>

Even at this early age it is clear that the image of God and its cosmological and numinous significance was of great importance for Jung. Indeed in his writings these concepts become of great consequence, the Imago Dei

---

<sup>1</sup> Jung, C. G., Freud, S., Freud/Jung Letters, (London, 1979), 49J

<sup>2</sup> Jung, Memories, Dreams, Reflections: p61-62

being one of the most important archetypes, or patterns in the collective and unconscious mind. Jung continued to have these religious or mystical experiences although they were confined to his number two personality; and perhaps the most striking of these is when,

'I saw before me the cathedral, the blue sky; God sits on His golden throne, high above the world - and from under the throne an enormous turd falls upon the sparkling new roof, shatters it, and breaks the walls of the cathedral asunder'.<sup>1</sup>

Jung had expected divine punishment for such a 'blasphemous' vision, however he received the opposite, an experience of grace, and responded emotionally to this numinous experience of the God Image,

'Instead of the expected damnation, grace had come upon me, and with it an unutterable bliss such as I had never known. I wept for happiness and gratitude'.<sup>2</sup>

Here it is possible to see the beginnings of an emphasis that runs throughout Jungian psychology which stresses the importance of sensation, experience, emotion and numinosity.

Jung just managed to pass his high school exams and immediately enrolled at the Medical School of Basel University. Unfortunately his father died in January 1896 and this brought severe financial pressures on Jung, but despite this he did well at university and went on to study for a doctorate. At this time his principal interest was in spiritualism as 'objective psychic phenomena'<sup>VI</sup> and for two years he attended the seances held by his cousin, the medium Helene Preswerk. He also took extra classes with Professor Wille in psychiatry and during the course of his reading he read Lehrburch der Psychiatrie by Krafft-Ebing. Straight away Jung applied for

---

<sup>1</sup> Jung, Memories, Dreams, Reflections: p50

<sup>2</sup> Jung, Memories, Dreams, Reflections: p50

a post at the Berghölzli Psychiatric Hospital in Zurich where Ebing was working, and he was accepted.

He seems to have found a great deal of freedom at Berghölzli although Ellenberger has described life there as a 'psychiatric monastery'.<sup>VII</sup> On rising at 6.30am there were first rounds followed by a staff meeting at 8.30am and there were no secretaries and the food was plain. Regular special meetings were called and evening rounds started at 5.30pm and were often not over until 10.00pm. In these conditions Jung was able to study patients suffering from dementia praecox, recently renamed by Bleuler (who was also at Berghölzli), schizophrenia. Here Jung formed his first tentative ideas on the complex and worked on word association tests as an objective way of uncovering complexes or repressions in the personal unconscious. He finished his thesis on Psychology and Pathology of So-called Occult Phenomena<sup>VIII</sup> and quickly afterwards, on 14th February 1903, married Emma Rauschenbach. However Jung felt that the work at Berghölzli was flawed because it took no account of the psychology of the individual, and instead it concentrated on obvious clinical symptoms and universal treatments. As he comments, 'From the clinical point of view which then prevailed, the human personality of the patient, his individuality, did not matter at all'.<sup>1</sup>

Jung was searching for, and beginning to develop an individual psychology and as early as 1900 he had read Freud's The Interpretation of Dreams. In 1903 Jung re-read the book and became excited; it seemed to him that the repressive mechanisms which Freud found in dreams he had also discovered with his word association tests. Jung commenced a lively and regular correspondence with Freud which, as has already been seen, assumed the

---

<sup>1</sup> Jung, Memories, Dreams, Reflections: p135

nature of an almost religious devotion to Freud. Despite this appearance of devotion, Jung maintained an independent mind and while continuing to publicly defend Freud, he created his own set of theoretical constructs,<sup>XI</sup> which were closely related to and, no doubt, inspired by Freud's thought.

Eventually Freud became the unquestioned father of the Viennese analysts, and after a few years collected around himself a group of highly respectable converts to the new psychoanalysis. However given Jung's independence this apparently comfortable psychoanalytic family could not maintain the pretence of unity. In June 1913 Freud finally felt unable to tolerate Jung's increasingly public divergence from his thought, and he wrote to one of the leading psychoanalysts, Abraham, saying, 'Jung is crazy but I have no desire for separation and should like to let him wreck himself first'.<sup>1</sup> However, before this on April 24th, Freud had already written to Abraham commenting, 'You were certainly just as surprised as I was how meticulously Jung carried out our own intentions; somehow we shall get rid of him and perhaps of the Swiss altogether'.<sup>2</sup> In the October of 1913 Jung, due to various manipulative pressures did leave the Freudian family. He wrote to Freud saying,

'It has come to my ears through Dr Maeder that you doubt my bona fides... Since this is the gravest reproach that can be levelled at anybody, you have made further collaboration impossible. I therefore lay down the editorship of the *Jahrbuch* with which you entrusted me'.<sup>3</sup>

Despite writing on several occasions, Jung was never to hear from Freud again. Quite why the schism finally occurred is uncertain, perhaps unconscious unsolved difficulties in the personalities of both Freud and Jung

---

<sup>1</sup> Brome, V., Jung, Man and Myth, (London, 1980): p151

<sup>2</sup> Brome: p153

<sup>3</sup> Jung, Freud, The Freud Jung Letters, 357J



were a contributing factor. However the conventional view of this issue is that they finally reached an impasse over the subject of sexuality, and indeed concerning sexuality, there is a clear difference between Jungian and Freudian models. Freud claimed that all neuroses were the result of sexual conflicts within the Oedipal Situation, but as far back as 1906 Jung was writing that, 'On the basis of my own findings I was still unable to feel that all neuroses were caused by sexual repression or sexual traumata'.<sup>1</sup>

During 1907-13 Jung published various papers including the Studies in Word Association, Psychophysical Research and the Psychogenesis of Mental Disease. He also published Wandlungen und die Symbole der Libido (1912). In English this was published as 'The Psychology of the Unconscious', and in it there is the first use of the term 'analytical psychology' as opposed to Freud's psychoanalysis. The first chapter dealt with thinking, intensive and directed, and the expression of images, symbols and myths in dreams and mythology. The significance of this book lies in the fact that it is Jung's first published work to mention the importance of comparative mythology, symbols and comparative religion. The book drew on such diverse sources as Gilgamesh, The Odyssey, The Bible, The Upanishads, Goethe, Nietzsche and other various philosophers, historians and theologians. It is not surprising that in this book there are the clear beginnings of Jung's thought on the important concepts of the collective unconscious and the psyche.

Jung grew to place more and more emphasis on myth, especially myth as an expression of the collective unconscious. As Anthony Storr puts it 'he

---

<sup>1</sup> Jung, Memories, Dreams, Reflections: p171

became certain that man must not be alienated from the myth-creating substratum of the mind which was shared by the normal person and the psychotic.<sup>1</sup>  
This awareness led Jung to ask the question,

'But in what myth does man live nowadays? In the Christian myth, the answer might be. "Do YOU live in it?" I asked myself. To be honest, the answer was no... "But then what is your myth - the myth in which you do live?"'<sup>2</sup>

This self questioning led Jung into a deep introspection and he eventually decided to open himself to the force of the unconscious, both collective and personal. Perhaps it is at this point that his psychosis proper began, and he describes the experience of this moment in Memories, Dreams, Reflections as falling into the unconscious, 'Suddenly it was as though the ground literally gave way beneath my feet, and I plunged down into dark depths'.<sup>3</sup>

This deliberate freeing of the unconscious resulted in a large number of dreams and in patterns of regressive behaviour. Jung began to recover memories and feelings from childhood, and he took to building a toy village. He spent much of the day walking along the shore of the lake searching for suitably shaped pebbles, naturally he asked himself the question, 'Why am I doing this?'. His reply was uncertain, 'I had no answer to my question, only the inner certainty that I was on the way to discovering my own myth'.<sup>4</sup>  
Jung never directly answers the question of what his own myth is but during the years of his psychosis he wrote only one book entitled, The Transcendent Function (1916).<sup>X</sup> Jung uses this term to indicate the process by which opposites are held in tension, especially the oppositions between conscious

---

<sup>1</sup> Storr, A., Jung, (London, 1973): p33

<sup>2</sup> Jung, Memories, Dreams, Reflections: p195

<sup>3</sup> Jung, Memories, Dreams, Reflections: p203

<sup>4</sup> Jung, Memories, Dreams, Reflections: p198

and unconscious. Perhaps his own myth is the myth of the unconscious. In other words, if a myth is something which holds an age old truth, then what Jung discovered was the true possibility of a life led in harmony with the unconscious. His myth is the truth of the unconscious.<sup>XI</sup>

By the time of Jung's psychosis, Antonia Wolff was living with the Jung family. She had first come to Jung for analysis in 1910, and he gradually came to rely on her more and more until eventually she came to live with the family. From the outset there was a considerable degree of intimacy between Carl and Antonia, but it is uncertain whether Emma guessed the truth for herself or if a jealous woman in a fit of anger disclosed that Carl and Toni were sleeping together.<sup>XII</sup> Emma suffered a great deal from her husband's affair, feeling that Toni's presence was detrimental to the family, and at this time she commenced a secret correspondence with Freud, who was a great admirer of hers. It is also possible that the tension generated when Jung discovered about the secret exchange of letters may have contributed to the split from Freud, and it would certainly seem as if the presence of Toni was one of the factors in Jung's psychosis. However, by 1916 Jung was recovering from his illness, although full recovery may not have occurred until 1929.

The period between 1920 and 1944 Jung spent travelling in the search for primitive cultures and fresh sources of mythological material. He visited Africa twice and India and New Mexico once. Wherever he went he became deeply involved with local rituals, even to the extent of endangering his own life and those of his travelling companions. After the first Africa trip Jung returned to Switzerland and started to build Bollingen. This was a circular stone house, inspired by the shape of the native African huts he had seen. It was built by the edge of a lake and, over the years, he gradually complicated the design by adding a tower and withdrawing room.

Jung's son Gustav has remarked, 'I had always been interested in building - I helped my father build Bollingen - but he wasn't really building. He was playing with sand castles'.<sup>1</sup> Thus Jung had returned once more to his childhood, to a form of play therapy. During his psychosis he had built a small village and now as a therapeutic exercise he built his own home. In the garden of Bollingen he erected a triangular stone pillar. He had ordered a square column but was delighted with the triangle that arrived, and again he took to a form of play as he carved inscriptions into the three faces of the stone. One face reads:

'Here comes the mean uncomely stone  
Tis very cheap in price!  
The more it is despised by fools  
The more loved by the wise'.

The inscription refers to the lapis stone used by the alchemists, and it was thought that this stone would aid in the transmutation of base metals into gold, the transformation of poverty into riches. The highly symbolic nature of alchemical practices was something which attracted Jung for many years,<sup>XIII</sup> and it seems fitting that in his own home he should erect a memorial to the stone of transmutation. Another hobby of Jung's, which is of particular relevance to this thesis, was reading detective fiction and Jaffe has pointed out that for Jung there was a connection between the alchemical figure of Mercurius and the detective.

'Reading detective stories was another pastime, and now in his seventies they lay around everywhere literally accumulating in piles on the top floor of the house...' "For Jung, Miss Jaffe said, "the figure of the detective was a modern version of the alchemical Mercurius, solver of riddles and he was entertained by his heroic deeds".'<sup>2</sup>

Jung also seems to have found a connection between the

---

<sup>1</sup> Brome: p200-201

<sup>2</sup> Brome: p249

detective figure and the psychiatrist. If the psychiatrist is thought of as someone on the search for the truth about the human condition, or as someone who solves the riddle posed by the human psyche, then this connection becomes clearer.

'He would sit there sucking away at his water-cooled pipe, oblivious to everything except the search for whodunnit. He commented, "It was so nice to have someone else solve the problem in a way which was entertaining and sent you to sleep instead of boring you and driving you mad".'<sup>1</sup>

It was on March 20th 1952 that Toni Wolff died. Towards the end of her life she had become a bitter and disillusioned woman and Jung had greatly reduced the amount of time he spent with her - in fact he did not even attend her funeral service. Three years later in the summer of 1955 Emma Jung died, Carl was greatly distressed and walked round the house sobbing that 'she was a queen'. Ruth Bailey was with the family at Emma's death and commented,

'Jung was very distressed - all white and tense - and not speaking. I remember shortly afterwards he came striding through the room in which all the family sat - silent, knitting, all afraid to say a word to him'.<sup>2</sup>

After Emma's death Jung alternated between periods of retreating into himself and vigorous debate. At one moment he would enjoy his solitude, the next he was enthusiastically defending his work in An Answer to Job (1952)<sup>XIV</sup> and attacking the Jewish theologian, Martin Buber. However Jung's health was deteriorating and after constant minor illness Jung died quietly on June 6th 1961, the time 4.00pm. He was resting in bed when his housekeeper arrived. Jung's last words were to her, 'Let's have a really good red wine tonight'. She left him to go to the cellar and by her return

---

<sup>1</sup> Brome: p257

<sup>2</sup> Brome: p260

his heart had stopped beating. He had died alone, peacefully and naturally of old age.

Post Script - Apocrypha

There is a story, which may have apocryphal elements, that two hours after Jung's death there was a violent thunderstorm and lightning struck the poplar tree under which Jung used to sit. The lightning apparently bounced down the trunk and was strong enough to dislodge some of the stones on the lower parapet of the house. 'Aniela Jaffe said: "From the open wound it had burned into the bark, I cut out a strip of bast. Then the gardener stopped up the wound with pitch and the tree is still alive today".'<sup>1</sup> Further, when Laurens van der Post was making a film about the life of Jung he went to the place of Jung's death at Kusunacht. At the moment he started to speak about the death, another thunderstorm occurred. Post commented in his biography of Jung,

'...the lightning struck in the garden again. The thunder crashed out so near and loud that I winced, and to this day the thunder is there in the film for all to hear... I am compelled to mention it because it would seem as if it is some sort of testimony of how that great spirit lives on and will continue to show the way towards the transfiguration of life until the end of space and time'.<sup>2</sup>

Having established the psychological context and biographical context, including the very important friendship and schism with Freud, it now seems appropriate to commence a brief investigation into Jungian theory to discover just what it is which made Jung so sure that Freudian sexual theory could not explain the totality of the human psychology. To begin with we shall examine Jung's personality theory and the concept of the psyche.

---

<sup>1</sup> Brome: p273

<sup>2</sup> Post, L. van der, Jung and the Story of our Time, (London, 1976): p265

JUNG'S THEORY OF CONSCIOUSNESS AND THE THEORY OF TYPES

The personality theory of C. G. Jung, the so called 'theory of types' or 'typology', is important because all of Jung's psychological thought is in some way connected to the concepts of personality, growth and development. Just how connected and cohesive Jung's thought is will become clear as further aspects of his theory are introduced. Further it is part of the intention of this thesis to examine the psychological function of characters within the detective film genre. To do this analysis effectively it seems important to have a psychological model for both the evaluation of characters in the film and the psychological characteristics of the societies which produce the films. Thus the specific applicability of this personality theory and the wider theoretical constructs of analytical psychology will be at their clearest, and most obvious, during the practical analysis of the detective films. These analyses occur later in the thesis after sufficient Jungian theory has been exposed, nevertheless constant tangential references to film theory will be made where these seem relevant.

To return to the theory: In his writings on the psychology of types, Jung is dealing with the psychology of consciousness and not the psychology of the unconscious. In this theory Jung identified two forms of approach that people adopt to the world, and these represent two quite opposite ways of reacting to conscious sense data.

'...there is a whole class of men who at the moment of reaction to a given situation at first draw back a little as if with an unvoiced "No", and only after that are able to react; and there is another class who, in the same situation, come forward with an immediate reaction, apparently confident that their behaviour is obviously right. The former class would therefore be characterized by a certain negative relation to the object, and the latter by a positive one... the former class corresponds to the introverted and the second to the extraverted attitude'.<sup>1</sup>

---

<sup>1</sup> Jung, C.G., 'Modern Man in Search of a Soul', (London, 1933). This edition (London, 1985): p98

The result of this is that with the extravert his attention is directed away from the inner world to the outside world. He is interested in events, people, whatever is happening around him, and in fact he is dependent upon these occurrences. While everyone is affected and orientated by data from the outside world the extravert relies heavily upon this information and cannot function without it. Thus the extraverted type is characterised by an outward flow of psychic energy.

An example of an extraverted type would be the character of Jake la Motta in Martin Scorsese's film Raging Bull, (Dir. M. Scorsese, Warner, 1980). This character has no apparent capacity for introspection and so all his energies are directed outward in a physical and aggressive attempt to attack the world. In the boxing ring he permits himself to be struck, just to prove that he can cope with pain, before finally destroying his opponent. At his home he constantly beats his wife for almost no reason at all. The film represents a cycle of impulsive and aggressive behaviour in which Jake shows no capacity for caring about anyone - not even himself. An example of this cycle occurs when he abuses his wife and as a result of this she leaves home only to return to yet another beating. Finally she leaves him, apparently for good, but her return seems almost inevitable. On another occasion Jake smashes his world championship belt to sell the jewels, when the intact belt was worth more than the dislodged gems.

The film ends with Jake a sad and broken club owner rehearsing the lines of his act into a mirror. His face is distraught, he is overweight and even the lines of speech are devoid of feeling. Jake still seems incapable of any form of introspection or self awareness. Scorsese ends the film with an ironic quotation from the gospel of Saint John, 'The Man replied, "Whether or not he is a sinner, I do not know, all I know is this: once I was blind and now I can see".' (John 9). The irony of this is that



Jake still has no sight either into the outer world or into the inner world of his unconscious. It is interesting to note that the real Jack la Motta served as an advisor to Scorsese.

The introvert represents the antithesis of the extravert position and is characterised by a withdrawal into the psyche and an inward flow of psychic energy. Typically the introvert lacks confidence in people and objects, he also has difficulty with relationships, preferring instead to withdraw into himself, and in so doing tends to appear antisocial. In contrast to the activity and dominance of the extravert the introvert is quiet and passive, preferring reflection to activity. It is when either introversion or extraversion become habitual that Jung feels it is justifiable to characterise the person as either an introvert or an extravert type.

In the film Equus, (Dir. S. Lumet, United Artists, 1977) there is a portrayal of an individual who has become almost totally introverted. The film's central character, Alan Strang, is so obsessed with his own fantasy world that he seems to have lost touch with reality. Alan believes that in horses there lives a god spirit whose name is Equus - this being the Latin for horse. He creates a complicated ritual of nocturnal horse riding in which a wooden stick, called the 'man bit', is placed between the naked rider's teeth. Alan also talks to Equus in a Christian phraseology, for example 'gentle Equus meek and mild' and 'Two shall be one', that is the horse and the rider. In his fantasy world Alan not only identifies himself with the horse; (at one point he makes a rope bridle which he wears as he beats himself) but also identifies the horse with Christ. An important moment in the narrative is when Alan enacts a corrupted version of the Christian eucharist using sugar cubes which both he and the horse eat.

Alan's psychic energy is totally directed towards the development of his own inner fantasy world and as such he is psychologically unable to cope with outer reality. For example, when he attempts to make love in the horse stables, the 'Temple of Equus', with Jill Mason he is unable to do so. His devotion has made him impotent and it is really only with Equus that Alan desires total intimacy. Unable to cope with the mixture of reality and fantasy, he calls on Equus, the 'all seeing God' to blind him and kill him. Still naked Alan hacks out the eyes of six horses and in so doing blinds Equus. As the psychiatrist in the film indicates Alan is psychotic, but he is still a clear example of how dangerous it can be to become totally introverted.

#### THE RELATIONSHIP OF INTROVERT TO EXTRAVERT

Frieda Fordham has noted that different cultures value these extraverted and introverted attitudes differently:

'In the West we prefer the extravert attitude, describing it in such favourable terms as outgoing, well-adjusted... in the East, at least until recent times, the introverted attitude has been the prevailing one. On this basis one may explain the material and technical development of the Western Hemisphere as contrasted with the material poverty but greater spiritual development of the East'.<sup>1</sup>

One of Jung's major contributions to psychology has been to show that the introverted position is not pathological<sup>XV</sup> (that is detrimental to psychological well-being) but is an integral part of the psychological character of everyone. Jung did not conceive of pure introvert and extravert types. He regarded the extravert as also having an introverted attitude, and vice versa, although one of the types assumes the dominant attitude and the other forms the subordinate, or inferior, attitude. Thus if someone has

---

<sup>1</sup> Fordham, F., An Introduction to Jung's Psychology, (London, 1953): p30

a balanced attitude they possess both introverted and extraverted attitudes in a state of tension with each other, each attitude competing for the energy of the ego.

As Fordham has also noted there is a tendency for the two types to communicate badly with each other,

'Unfortunately the two types misunderstand one another and tend to see only the other's weakness, so that to the extravert the introvert is egotistical and dull, while the introvert thinks the extravert superficial and insincere'.<sup>1</sup>

In personal relationships the situation is further complicated because often the opposite types attract each other, as unconsciously the extravert may seek to find an introverted type in an effort to balance their own subordinate attitude. Thus there seems to be a strangely contradictory sense in which oppositions are needed, because they bring with them balance and stability.

Clearly, by themselves these notions of extravert and introvert are only of a limited use, however they form the basis of Jung's personality theory. To see how Jung extended this theory into a useable and complex system it is necessary to return to the time he spent working at the Berghölzli hospital.

Here he was able to study the fantasy material produced by patients suffering from various forms of schizophrenia, and during this period he also studied his own dreams and attempted an in-depth analysis of his own personality. From these observations he formulated a more complex theoretical framework and devised a series of terms for speaking about the psyche. By

---

<sup>1</sup> Fordham: p33

the term 'Psyche' Jung meant the totality of the self, in other words all that makes us human whether this is conscious and unconscious. It is now proposed to study the model and language that Jung devised, and to do so in detail.

### The Psyche

One of the first and most basic distinctions that Jung made was between the conscious and unconscious mind,

'Whatever we have to say about the unconscious is what the conscious mind says about it. Always the unconscious psyche, which is entirely of an unknown nature, is expressed by consciousness and in terms of consciousness, and that is the only thing we can do'.<sup>1</sup>

It is important to note that Jung is claiming the only clues we have about the unconscious are derived from a conscious expression of unconscious contents. Thus the unconscious is the primary experience which finds expression in the secondary experience of consciousness. In seventeenth and eighteenth century French and English psychology there was an attempt to form concepts about consciousness based only on information gathered by the senses, and so at this period in history consciousness was thought to be composed of only stimulus sense data. This concept found expression in the often cited phrase, 'Nihil est intellectu quod non fuerit in sensu'.<sup>XVI 2</sup>

It is interesting to note the position adopted by Freud on the nature of the unconscious is somewhat similar, as he postulated theories about the unconscious which came only from conscious sense data. For example, he assumed that dreams are not a matter of chance but rather they are associated with conscious thoughts and problems. However for Jung the unconscious is paramount, as it is only through its manifestation in dreams,

---

<sup>1</sup> C. W. 18: 8

<sup>2</sup> Leibniz, C., Nouveaux Essais sur l'Entendement Humain, Bk.11, Ch. 1, Sec.2

myths, symbols etcetera that anything of its elusive character can be discerned, and so Jung claimed the primacy of the unconscious. He believed that man is not born with an unstructured mind, in fact rather the opposite is true, and even the youngest baby has a series of conditioning psychological structures which he claims are located in the unconscious mind, but find expression through consciousness.

'Thus man is born with a complicated psychic disposition that is anything but a tabula rasa. Even the boldest fantasies have their limits determined by our psychic inheritance, and through the veil of even the wildest fantasy we can still glimpse the dominants that were inherent in the human mind from the very beginning'.<sup>1</sup>

Jung subdivided the psyche into what he termed the endopsychic and ectopsychic systems. The term ectopsychic system corresponds roughly to what Jung referred to as the conscious psyche. To be more exact the term refers to the system of relationships that exist between the conscious part of the psyche and the stimuli which originate in the environment, that is to say outside the psyche. It is therefore a system which helps orientate the psyche with external facts from the senses. The endopsychic system represents the system of relationships between the conscious and unconscious parts of the psyche. It is now proposed to examine the functioning of these two systems.

### The Ectopsychic System

The ectopsychic sphere is composed of four sections, sensation, thinking, feeling and intuition. Ever since the inception of these terms there has been a degree of misunderstanding as to exactly what Jung intended. As these are to become terms in this thesis and as they are central to ana-

---

<sup>1</sup> C. W. 8: 719

lytical psychology it may prove useful to have a brief definition and clarification of their Jungian meaning. First sensation:

'By sensation<sup>XVII</sup> I understand what the French psychologists call "la fonction du réel", which is the sum-total of my awareness of external facts given to me through the function of my senses... Sensation tells me that something is: it does not tell me what it is and it does not tell me other things about that something; it only tells me that something is'.<sup>1</sup>

An example of a sensation type can be found in King Kong (Dir. D.O'Selznick, RKO, 1933). In this film the giant ape Kong operates almost totally on the level of sensation, in other words he just responds to situations as they are. For example when Kong is taken to New York he searches the city for Anne, who was going to be his bride. At one point Kong reaches inside a bedroom and finds a woman, but when he recognises that it is not Anne he lets her fall to her death. As Kong operates at the level of sensation he has no evaluative functions, apparently he is aware that things exist but he has no sense of their value, which explains why he ruthlessly discards the woman. Eventually Kong does find Anne and he climbs with her to the top of the Empire State Building. Here he is attacked by airplanes and realising that his death is imminent, and in a moment of sensual awareness, Kong puts down the girl, after which he falls to his death. Standing beside Kong's corpse, Denham remarks, 'It was not the aircraft which killed Kong, it was beauty that killed the beast'. Perhaps in Jung's terms it was sensation which overwhelmed the beast, or rather it was the final understanding that he could not get beyond sensation.

Now that Jung's definition of 'sensation' has been demonstrated and juxtaposed with a filmic example, it is possible to venture deeper into the ectopsychic system. The next step inward moves past the mere collection

---

<sup>1</sup> C. W. 18:21

of data from the environment, which was the sensation stage, and deals with the psyche's ability to organise this data according to name and category. The term which Jung uses for this process is 'thinking'.<sup>XVIII</sup>

The Psyche: The Ectopsychic System

(Based on the model used by Jung in 1935 Tavistock Lectures)

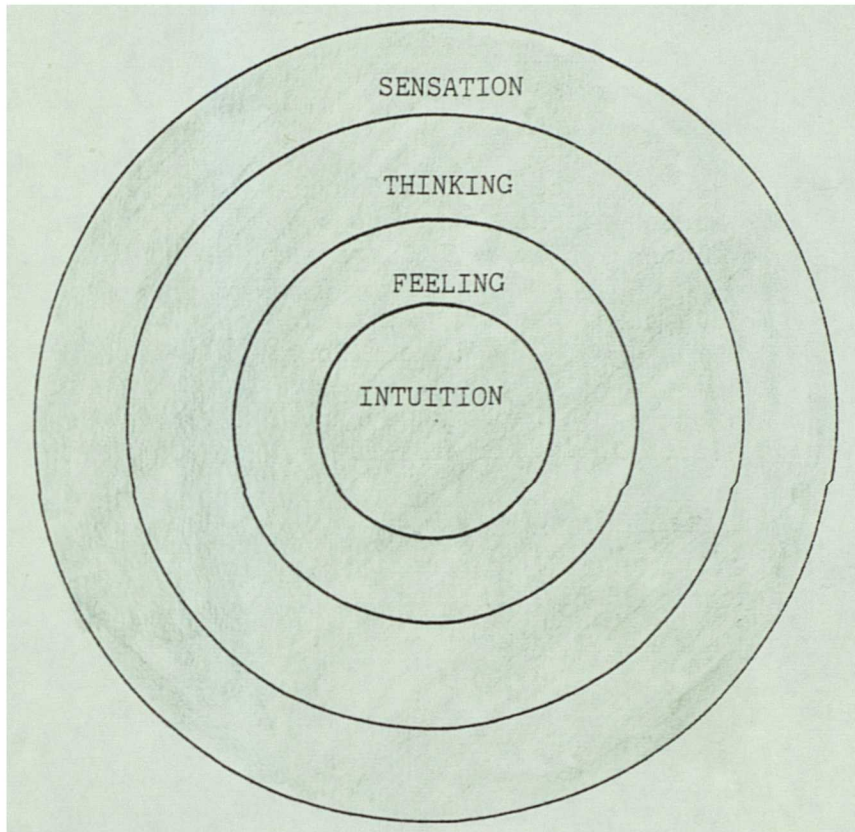

'Thinking in its simplest form tells you what a thing is. It gives a name to the thing. It adds a concept because thinking is perception and judgement'.<sup>1</sup>

In the film Star Trek the Motion Picture (Dir. R. Wise, Paramount, 1979), there is an example of an extreme thinking type. The character Spock is the Chief Science Officer of the Starship Enterprise, and an insight into his dependence upon thinking is given through his 'catch phrase', 'that is

---

<sup>1</sup> C. W. 18:22

illogical', which indicates a reliance on rationality, and it is an inevitable consequence of this emphasis that feelings and emotions are devalued. To make this extreme intellectual position acceptable Spock is represented as being a Vulcan, and his pointed ears and slanted eyebrows serve as a constant visual reminder of these alien origins. The viewer's initial encounter with Spock takes place as he is participating in a ceremony on the planet Vulcan, the purpose of which is to initiate him into the realm of total logic. An important part of the ritual is cited below,

High Priestess, 'Our ancestors cast out their animal passions here on these sands. Our race was saved by the attainment of Kolinahr'.

Acolyte, 'Kolinahr: through which all emotion is finally shed'.

High Priestess, 'You have laboured long Spock... Now receive from us this symbol of total logic'.

Star Trek, the Motion Picture

Unfortunately Spock is to be frustrated in his aspirations to enter the realm of total logic. The reason for this is that his mother was human, and so his Vulcan ancestry has become polluted with the capacity for feelings and emotions, and consequently he is unable to receive the symbol.

The film seems to be aware that while thinking is a vital human function, it must always be supported with the other elements in the ectopsychic system, and later in the film Spock achieves this realisation for himself. This moment of insight occurs when he comes into contact with a living machine called Vger and he comments, 'Yet with all its pure logic Vger is barren, cold, no mystery, no beauty, I should have known... this simple feeling is beyond its comprehension'. With this insight Spock elevates himself above the level of a 'living machine' and accepts his 'polluted' human blood.



Going deeper into the ectopsychic system the third function which Jung distinguishes is feeling. At this point Jung becomes slightly more controversial for he claims that feeling is as rational as thinking<sup>XIX</sup> and for him feeling is a way of evaluating an experience or object's worth or value. As he comments,

'Feeling informs you through its feeling-tones of the values of things. Feeling tells you for instance whether a thing is acceptable or agreeable or not. It tells you what a thing is worth to you... Now the "dreadful" thing about feeling is that it is, like thinking, a rational function'.<sup>1</sup>

The final and deepest function of the ectopsychic system is altogether more difficult to describe as it is concerned with an area of the psyche that is largely unknown. As Jung's critics have been quick to point out, at this point his theory seems to become somewhat 'mystical', which if we are dealing with the unknown, is perhaps not surprising. Quite why 'mystical' should be used as a pejorative term is uncertain, however this may be an indication of the amount of support for behaviouristic theories. It would appear that when Jung talks of intuition,<sup>XX</sup> he is claiming that it is a form of perception, although it is perception not via the senses but through the unconscious.

'That is what is called intuition, a sort of divination, a sort of miraculous faculty... you "get an idea", you "have a certain feeling", as we say, because ordinary language is not yet developed enough for one to have suitably defined terms. The word intuition becomes more and more a part of the English language, and you are very fortunate because in other languages that word does not exist'.<sup>2</sup>

An example of a typical intuitive type can be found in the film 2010 (Dir. P. Hyams, MGM, UA, 1984). In this film the central character, Dr Heywood Floyd, constantly relies upon his intuition to inform him about

---

<sup>1</sup> C. W. 18: 23

<sup>2</sup> C. W. 18: 24

what is happening in the world. Dr Floyd is on a mission to rescue the abandoned space ship Discovery, and to activate the shutdown HAL 9000 computer. His speech is full of references to things which he 'feels' or 'thinks' are true, and it is his intuition which tells him that these things are real. For example, he remarks, 'I tell you there's some kind of life...I also think it knows we're here' and, 'We have so much to ask. I've a feeling that the answers are bigger than the questions'. In both these examples, which are typical of his speech, Dr Floyd has no rational evidence for his assertions he just 'knows' and this leads one of his crew, Tanya Kirbuk, to remark, 'Dr Floyd, you're not a very practical man'.

After the HAL 9000 has been reactivated Dr Floyd has a vision in which one of the dead members of the Discovery, David Bowman, appears to him. The apparently dead Bowman asks him to 'Please believe me' and to leave the planet Jupiter which they are orbiting within two days because, 'something is going to happen, something very wonderful'. Dr Floyd is somewhat shaken by this communication but is able to cope, but to do so he relies upon his intuitive faculties, and in fact he has no option but to do this because the appearance of Bowman is not understandable within any other terms. As Jung comments, intuition is 'divination', a 'miraculous faculty'. Dr Floyd takes this divination very seriously and overcoming many difficulties leaves the area within the two day deadline. In the film intuition is validated because on the second day Jupiter explodes forming a new sun and on a nearby planet a whole new process of life begins. There is quite literally another creation, the universe is reborn, as Floyd in his concluding speech remarks, (we) 'looked up and realised we were only tenants of this world. We have been given a new lease by the landlord'.

To return to the ectopsychic system, its four functions of thinking, feeling, sensation, intuition, actually form the basis of Jung's complicated person-

ality theory which is called the 'theory of types', or more accurately 'typology'. Jung claimed that in a given individual one of the four functions would be dominant, for example thinking. Thus this person could be classified a 'thinking type'. However every 'type' is composed of two of the four elements in the ectopsychic system, thus there is a secondary or inferior function to the personality, and for the thinking type this is feeling. However it should be stressed that just because an individual is a thinking type with an inferior feeling function, it does not mean that this individual's sensation and intuition elements are lost. Quite the opposite, in fact they form active elements within the psyche and exist in a state of tension with the dominant attitude and functions and the inferior elements. Jung terms this whole approach to personality theory 'dynamics' thereby indicating the state of flux, tension and development that the psyche is in.

### The Endopsychic System

So far this chapter's consideration of the psyche has been concerned with the ectopsychic system, however these conscious functions are supported, or are in tension with a variety of unconscious elements, which are the property of the endopsychic system. Like the ectopsychic system there are four elements to the endopsychic system, and these four elements each get progressively more and more difficult to understand as they get deeper into the psyche.

The first, and outermost, of the four functions identified by Jung is memory. For Jung this is connected with things that may at one time have been conscious but have now faded away, that is to say with things that at one time belonged to personal consciousness but have now been 'forgotten'.

Thus this type of memory is principally a collection of repressed, hence unconscious, personal events.

'What we call memory is this faculty to reproduce unconscious contents, and it is the first function we can clearly distinguish in its relationship between our consciousness and the contents that are actually not in view'.<sup>1</sup>

The second endopsychic function is more difficult to describe and it is called by Jung 'The subjective components of conscious functioning'.

'Every application of a conscious function, whatever the object might be, is always accompanied by subjective reactions which are more or less inadmissible or unjust or inaccurate. You are painfully aware that these things happen to you, but nobody likes to admit that he is subject to such phenomena'.<sup>2</sup>

These subjective components get left or pushed into the darker or shadow side of the psyche and this repression helps in coping with these 'undesirable thoughts'. The concept of the shadow is an integral part of Jung's personality theory, for as well as possessing dominant and inferior functions a given individual will also have a shadow side. This is the negative side of the personality and Jung describes it as, 'The sum of all the unpleasant qualities one wants to hide, the inferior, worthless and primitive side of man's nature, the "other person" in one, one's own dark side'.<sup>3</sup>

The shadow is so much an "other person" that it may assume a character and life all of its own and this is often clearly observed in mythological material. For example when the hero is forced to fight some species of evil monster, or when the detective combats a particularly evil criminal, both the monster and criminal may be projected personifications of the hero's shadow.

---

<sup>1</sup> C. W. 18:39

<sup>2</sup> C. W. 18:40

<sup>3</sup> Samuels, A., Shorter, B., Plant, A., A Critical Dictionary of Jungian Analysis, (London, 1986): p138

An example of this type of projected personified shadow can be observed in the film Tightrope, (Dir. R. Tuggle, Warner, 1984). In this film police detective Wes Bloch is attempting to catch a killer of prostitutes who is loose in the city of New Orleans. Each time the murderer strikes, he handcuffs his victims, and ties them with red ribbon, he then rapes them and finally kills them. Throughout the process in an effort to conceal his identity, he wears a mask. The first time the viewer sees the killer his face is concealed in shadow and it is possible to regard the killer as the detective's shadow (one of the characters in the film even remarks to Bloch of the killer, 'He said you were just like him'). The notion of the killer as the detective's shadow is reinforced in the film when Detective Wes Bloch goes to visit a criminal psychiatrist who comments, 'Once you started going after him you became closer to him than anyone else'. She adds,

'There's darkness inside all of us Wes; you, me and the man down the street. Some have it under control, some act it out, the rest of us try to walk a tightrope between the two'.

#### Tightrope

It would seem that Bloch's shadow, his darker side, is out of control and it is not until the end of the film that he is able to capture and destroy his shadow. The final battle is a protracted one and it is not until the killer's body is crushed by a train that he is destroyed, even so the killer/shadow leaves his severed arm still gripping Bloch's throat. To further support this interpretation of the killer as the detective's shadow it is interesting to note that the killer is in fact an ex-policeman. The message of the film, in Jungian terms seems clear: embrace your shadow and walk the tightrope.

The Psyche: The Ectopsychic and Endopsychic Systems

(Based on the model used by Jung in 1935 Tavistock Lectures)

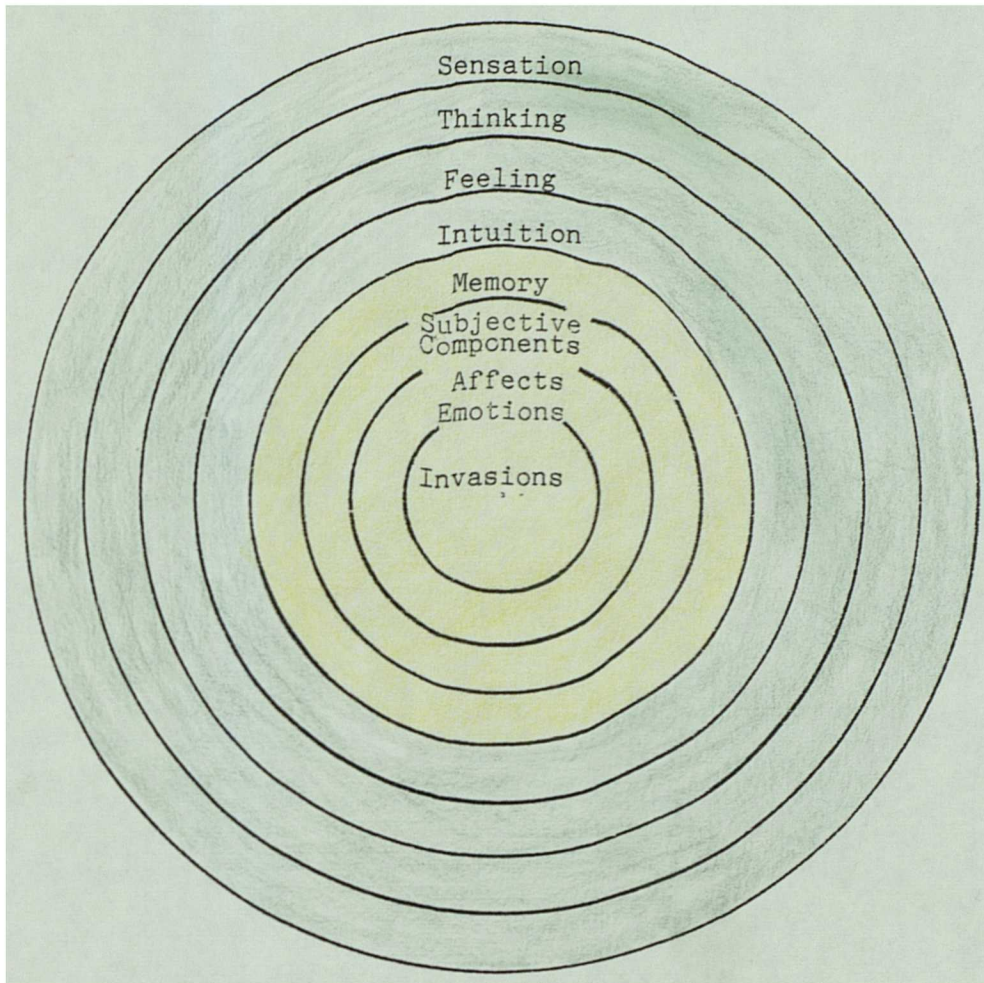

The third endopsychic component is where the affects and emotions occur, and here the psyche is losing control over its conscious sections. To refer back to memory, everyone knows how easy it is to 'deliberately forget' events. This is of course a moment when the unconscious asserts itself and an individual temporarily loses control over their functions. With emotions and affects Jung claims that it is no longer possible to speak of functions but only of events. In other words the functions have become experiential.

'The primitive does not say he got angry beyond measure; he says a spirit got into him and changed him completely. Something like that happens with emotions; you are simply possessed, you are no longer yourself, and your control is decreased practically to zero. That is a condition in which, the inner side of a man takes hold of him, he cannot prevent it'.<sup>1</sup>

<sup>1</sup> C. W. 18:42

Good examples of this state might be when an individual is obsessed with an idea or cause, when someone is unaccountably moody, or perhaps when someone first falls in love. In all these cases the emotions well up and like a rising river they spill over the banks of the unconscious and into consciousness and the psyche is swept along, caught in this sudden flood of emotions and affects.

To return to the film Tightrope, before the film started Detective Wes Bloch was outside the world of prostitution. However after his wife left him he became a 'vice cop' and he got drawn deeper and deeper into the sexual underground. As mentioned above, in Jungian terms, the killer represents the detective's shadow and as Wes gets progressively involved with the prostitutes so he adopts the sexual perversions of their killer. As the film's narrative develops Bloch's shadow gradually takes control of his consciousness and he becomes intertwined with the murder investigation, as each prostitute he has sex with is then murdered by the killer/shadow. Tightrope seems to depict Bloch's growing loss of self control and as the film unfolds his shadow assumes a dominance which results in his sexual exploits becoming both more aggressive and perverted. This point is illustrated by the following conversation which takes place between Wes and his girl friend.

Beryl - "Do you investigate many sexual crimes?"

Bloch - "Why?"

Beryl - "Just wondered if they'd affected you"

Bloch - "They did want me to treat my wife a little more tenderly"

Beryl - "How did she respond?"

Bloch - "She said she wasn't interested in tenderness..."

#### Tightrope

The film's constant reference to sexually perverted practices indicates the move Wes has made away from the world of tenderness to the world of bondage prostitution. It is only after he has realised how he has been affected by

this realm that he is able to 'cast out' the spirit, that has possessed him, and embrace his shadow. Of course it is shortly after this moment of self realisation that he is able to capture and destroy the killer/shadow.

The final and fourth endopsychic factor is termed by Jung 'invasion'. Here the consciousness is not just partly out of control but is totally powerless because it has been invaded with the full strength of the unconscious psyche. This condition, which is characterised by extreme emotions, is not necessarily pathological - that is detrimental to psychological well being. The condition is just a forceful assertion of the unconscious and these events may indeed lead to a neurosis. As Jung comments,

'These phenomena are not in themselves pathological; they belong to the ordinary phenomenology of man, but if they become habitual we rightly speak of a neurosis. These are the things that lead to neurosis; but they are also exceptional conditions among normal people'.<sup>1</sup>

### CONCLUSION

This brief introduction to Jungian personality theory is important because in one way or another all Jung's theories are related to the growth of the personality, or if it is preferred, the development of the psyche. Thus these personality theories form a useful theoretical framework for presenting the wider and more complicated aspects of analytical psychology. Further, if a hero, or any character's motivation is to be understood then some awareness of his psychological character is necessary. Again to place the characters within their psychological cultural context some knowledge of personality theory, which applies on a cultural as well as individual scale, is important. Such terms as sensation, intuition and shadow will

---

<sup>1</sup> C. W. 18: 43



prove central concepts in discussing filmic characters in their cultural/mythological context.

This chapter has sought to examine Jung's psychology of consciousness and to see this in relation to his typological theory.

Expressed in a summarised form the Jungian model of the psyche has the following elements:

Ectopsychic System - The most conscious levels of the psyche:

- 1) Sensation - information that world objects exist, that things are.
- 2) Thinking - naming and organising the sense data.
- 3) Feeling - as rational as thinking, an evaluation of an event's worth to us.
- 4) Intuition - perception not via the conscious but the unconscious.

Endopsychic System - The deeper and more unconscious levels of the psyche:

- 1) Memory - the recall of repressed 'forgotten' personal events.
- 2) Subjective components - the shadow, the negative aspects of an individual's personality, often personified as a separate individual.
- 3) Emotions and affects - partial loss of the conscious self as the unconscious takes over or possesses the psyche.
- 4) Invasion - total loss of control over the psyche as it is overwhelmed by the unconscious.

This state is often highly emotional although it is not necessarily pathological.

CHAPTER ONE NOTES

- I. Behaviourists have been anxious to defend themselves on this charge and for an example of this c.f. Skinner, B. F., About Behaviourism, (New York, 1974).
- II. B. F. Skinner's theory of learning and Chomsky's theory of language acquisition (L.A.S.) can both be considered as 'black box' theories.
- III. c.f. O'Neil: p8
- IV. c.f. O'Neil: p11
- V. Brome, V., Jung, Man and Myth, (London, 1980): p38
- VI. c.f. C. W. I: 1-150
- VII. Brome: p72
- VIII. c.f. C. W. I: 1-150
- IX. Jung, Memories, Dreams, Reflections: p171
- X. c.f. C. W. 8: 131-193
- XI. c.f. C. W. 9,I: 302
- XII. Brome: p131
- XIII. c.f. C. W. 12, 13, 14
- XIV. c.f. C. W. 11
- XV. For much of his work on this area Jung drew on Eastern sources.  
c.f. C. W. 11 passim
- XVI. 'There is nothing in the mind that was not in the senses'.
- XVII. c.f. C. W. 6: def 47
- XVIII. c.f. C. W. 6: def 53
- XIX. C. W. 6: def 44
- XX. C. W. 6: def 35

Chapter Two

C. G. Jung's Psychology of the Unconscious  
and Film Theory

This chapter seeks to build upon the foundations laid by the previous chapter, by expanding both the presentation and application of C. G. Jung's analytical psychology. In the preceding chapter Jung's psychology of consciousness, including the personality theory, was examined and its relevance and applicability to the analysis of film was demonstrated. This chapter explores Jung's concept of the unconscious and does so with specific reference to his concepts of the objective psyche, archetypal patterns, symbols, dreams and the individuation process. The aim of this chapter is to continue the process of connecting up between analytical psychology and films. However unlike the previous chapter, this is not achieved at the level of practical film analysis, but by demonstrating points of correspondence between film theory and the theory of analytical psychology.

There is the question as to why films should be regarded as a particularly apt medium for expressing the objective psyche. It was mentioned in the introduction to the thesis (p 4) that Jung considered film to be an especially versatile medium and because of this the number and variety of imaginary, fantasy or fictional worlds that can be created is huge. It is also a specifically visual medium and as such has, at least some, affinities with the dream, which is the most intimate way in which the objective psyche expresses itself. This is not a particularly new insight for film theory as over thirty years ago Parker Tyler noted,

'Briefly movies, similar to much else in life, are seldom what they seem. In this sense - being, to begin with, fiction - movies are dreamlike and fantastic... These assumptions are simple: (a) the existence of the unconscious mind as a dynamic factor in human action and (b) the tendency of screen stories to emphasize - unintentionally - neurosis and psychopathic traits discovered and formulated by psychoanalysis'.<sup>1</sup>

---

<sup>1</sup> Tyler, P., The Magic and Myth of the Movies, (London, 1971): p28

While Tyler is writing from within a broadly Freudian position, his general observations are still applicable, although as Parts Two and Three of the thesis will demonstrate the situation is more complicated than he suggests.

#### THE OBJECTIVE PSYCHE AND ARCHETYPAL PATTERNS

So far this thesis has not considered what is the most important element in analytical psychology that is, the postulated existence of the 'collective unconscious'. (Jung later withdrew this term and renamed this construct the 'objective psyche',<sup>I</sup> and it is this revised term that this thesis will retain). At the centre of the endopsychic system Jung thought that there existed a central unconscious collective core. This unconscious core is the repository for the psychological experience of mankind, and it also contains the plan or pattern for mankind's psychological development. For Jung the collective, as in this collective core, is the antithesis of the individual, or rather the collective is that from which man must separate himself if he is to become fully individual and hence fully human. Thus the objective psyche contains both the entire psychological record of mankind and the information necessary for individuation, or separation, from that collective.

It should again be stressed that knowledge of the objective psyche can only be obtained through the ectopsychic system, or if it is preferred - through the conscious senses. So within the psyche there are two different unconscious elements; there is the personal unconscious and the wider objective psyche. While these elements are in theory separate, in practice they inter-relate and inter-react to such an extent that it is not always a simple task to decide what material is personal, and what belongs to the wider collective objective psyche.

To illustrate this point there follows a diagram which is a development of those in the previous chapter, and it has been extended to show the ectopsychic and endopsychic elements in relationship to the objective psyche.

The Psyche: The Ectopsychic, Endopsychic Systems and  
the Objective Psyche

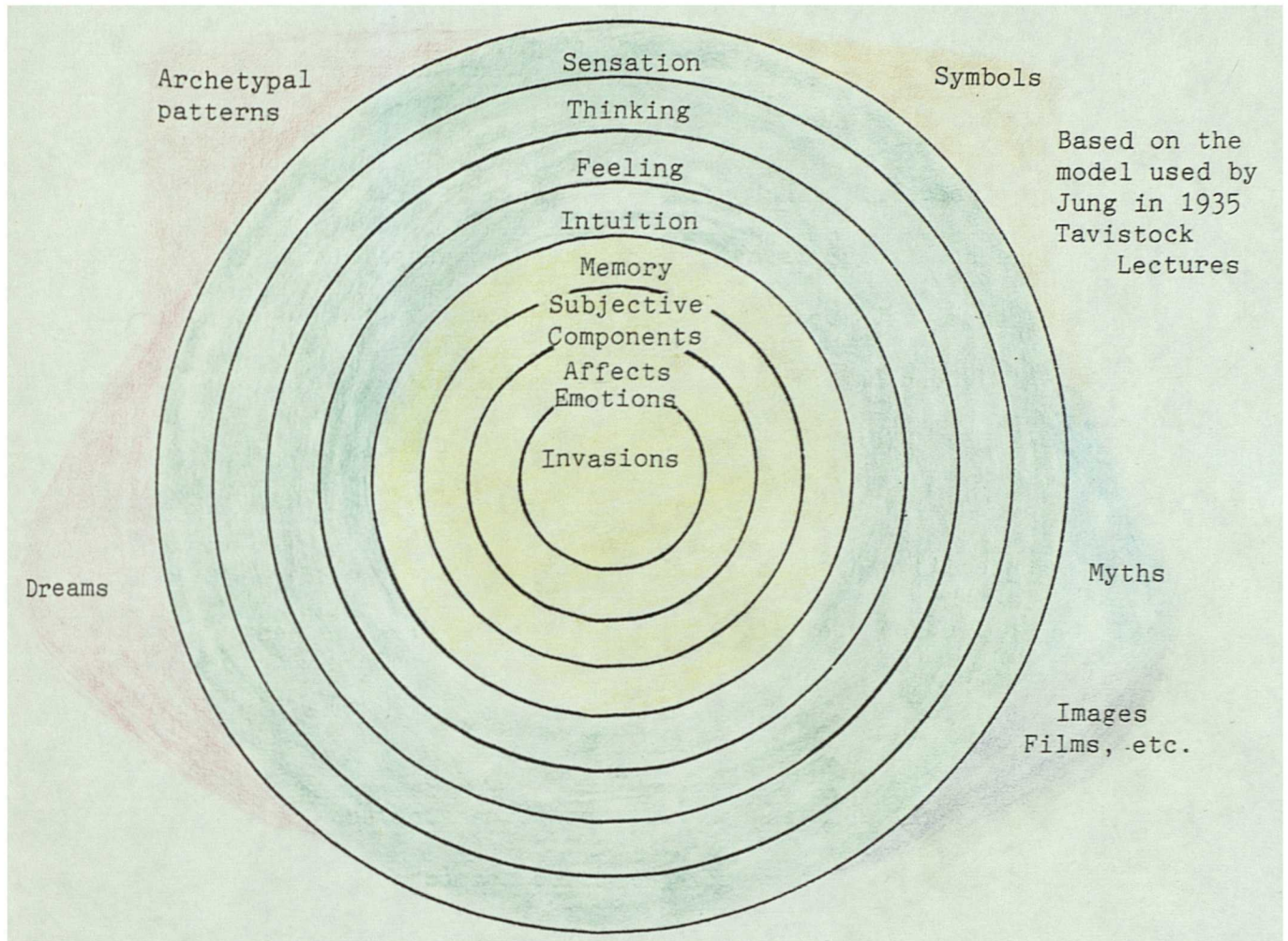

Some film theoreticians have sought to find an expression of the objective psyche (collective unconscious) in films, and the underlying assumption of this is that films are an expression of shared latent psychological needs. For example Carpenter claims that television has played a vital role in revealing this process, 'When Hollywood films were films, they were lived; as late television shows, they can be studied, seen for what they are: part of our collective unconscious.'<sup>1</sup>

<sup>1</sup> Carpenter, E. C., Oh what a blow that Phantom gave us, (London, 1976): p56

To return to the psychological theory it is important to note that Jung's hypothesis of the objective psyche is the result of empirical research in a variety of areas. For example he observed his own dreams and those of his patients at Berghölzli; he analysed fantasies and delusions and he became interested in comparative religion and mythology. Out of this welter of material Jung eventually noticed that in all these areas there seemed to be certain recurring myth themes or patterns.

To an extent there is a relationship between Jung's interest in mythological material and anthropology, for both treat myth as an expression of latent structures and needs within a given culture. Jarvie has recognised in films the expression of these latent structures and needs, 'Apart from anthropological field work, I know of nothing comparable from the point of view of getting inside the skin of another society as viewing films made for the home market'.<sup>1</sup> The assumption seems to be that films possess something of the nature of myths in that they reflect concealed and hidden societal structures.

Again some film theoreticians regard films not as individual, and therefore 'authored' products but as cultural expressions of a 'fundamental motif' which is the 'common property of all mankind'. As Monaco has commented, 'The "auteur theory" as applied to cinema is thus not only historically inaccurate but also fundamentally misleading. Movies are not "authored" but are rather reflections of shared thoughts and structures'.<sup>2</sup>

---

<sup>1</sup> Jarvie, I. C., Towards a Sociology of the Cinema, (London, 1970): p4

<sup>2</sup> Monaco, P., 'Film as Myth and National Folklore', In: The Power of Myth in Literature and Film, ed. Carrabino, V., (Tallahassee, 1980): p39

With regard to these recurring myth themes or patterns, it should be stressed, at this point, that what is inherited or passed on in the objective psyche is not its content in images, but its pattern. For example the form 'hero' is a pattern, but its content, that is its image, may vary from culture to culture and age to age. At one moment it may be a medieval knight, the next a detective and then a space warrior. The pattern, 'hero', remains constant, but its image is constantly renewed. The reason for this distinction will become clear later in the thesis, at this stage it is sufficient to note it and to note Jung's keenness to stress the distinction between pattern and image.

'The autonomous contents of the unconscious, or, as I have called them, dominants, are not inherited ideas but inherited possibilities, not to say compelling necessities, for reproducing the images and ideas by which these dominants have always been expressed... It matters little if the mythological hero conquers now a dragon, now a fish or some other monster; the fundamental motif remains the same, and that is the common property of mankind, not the ephemeral formulations of different regions and epochs'.<sup>1</sup>

For Jung myths, symbols and religious experiences are all connected to the objective psyche, but rather than regard the objective psyche as an expression of these elements, he inverted this and thought of religious experience as only available from the objective psyche as are myths, symbols, et cetera. Thus myths are a manifestation of the objective psyche, as is religious experience. As he commented,

'He will have set his hand, as it were, to a declaration of his own human dignity and taken the first step towards the foundations of his consciousness - that is, towards the unconscious, the only available source of religious experience. This is certainly not to say that what we call the unconscious is identical with God or is set up in his place. It is simply the medium from which religious experience seems to flow.'<sup>2</sup>

---

<sup>1</sup> C. W. Vol.8: 718

<sup>2</sup> C. W. 10: 565



The dominants referred to by Jung,<sup>II</sup> are more regularly termed by him archetypes. This term has passed from being a technical psychological term into common usage and in this transition its meaning has changed. More often than not, the terms 'archetype' and 'stereotype' are treated as interchangeable but in analytical psychology the term 'archetype' refers to the structuring potentials latent in the objective psyche. These potentials govern the psychological life of an individual, regulating the development and balance of the psyche to ensure that the psyche remains healthy and adjusted to life in the world. Whereas 'stereotype' implies a conformity, or caricature of an original 'type'.

As an individual develops, so he or she moves through different archetypal phases, the so-called 'mid life crisis' is an obvious example of one such phase. Thus throughout life many different archetypal patterns are brought into play, much as the body at puberty automatically starts hormonal changes, so too the psychic system may at certain times produce archetypal guidance. The archetypes may be thought of as a controlling or regulating potential which develops, or unfolds, over a period of time. The archetype therefore links together body and psyche and as such is a psychosomatic concept.<sup>III</sup>

In his book The Long View, Basil Wright has commented on the psychosomatic dreamlike nature of films and as such seems to regard films as expressions of the objective psyche. For Wright, films indicate a link between body or 'outer world' and psyche or 'inner world', and he comments that the film seems to be one way in which the objective psyche expresses its archetypal guiding images,

'I wish Jung had paid more attention to cinema, especially in terms of those filmic illogicalities which are often, ... only acceptable in terms of (a) dream... but can, perhaps, be accepted as signals reaching us from inner rather than outer space'.<sup>1</sup>

---

<sup>1</sup> Wright, B., The Long View, (London, 1976): p11

Archetypes are recognisable in our outward and everyday behaviour, which of course includes film making, especially when this is connected with what Jung calls 'universal events' for example, birth, death or marriage. It is at these moments that the archetypes of the objective psyche are at their most active, and may therefore be most clearly observed. Typically they assume such figures as the hero or shadow, but Jung is always at pains to indicate that these images, the visualisations of one archetypal pattern or another, do not reveal the whole nature of an archetype. They merely represent one of the pattern's many facets, and what an archetype is remains ultimately inexpressible.

'We must, however, constantly bear in mind that what we mean by "archetype" is in itself irrepresentable, but has effects which make visualisations of it possible, namely, the archetypal images and ideas. We meet with a similar situation in physics: there the smallest particles are themselves irrepresentable but have effects from the nature of which we can build up a model. The archetypal image, motif or mythologem, is a construction of this kind.'<sup>1</sup>

These archetypal patterns wait to be released in the psyche, and they are released in the form of creative acts, symbols, myths, dreams, and films. These expressions of the objective psyche are capable of a wide degree of variation, this variation being dependent upon an individual's own life experiences and cultural expectations.

Monaco has commented that films too contain collective unconscious meanings and as such are expressions of the objective psyche. He further claims that much as an individual's own life experience causes a variation in the contents of archetypal expression, so too cultural changes cause filmic contents as archetypal expressions, to vary. Thus analysis of these filmic contents may reveal their underlying psychological nature.

---

<sup>1</sup> C. W. 8: 417

'Latent collective meanings of films reveal themselves through analysis of surface film contents... In some instances, however, the repetition or stylization of certain such devices and techniques in the popular films of a nation may reveal important psychological tendencies'.<sup>1</sup>

Archetypal experiences are characterised by a strange sense of energy and power which is called by Jung, who borrowed the term from Rudolff Otto, a 'numinous' experience. The strength of the numinous experience may be so strong that during the event the person who is undergoing the encounter may think his or her self mentally ill. As a result of this contact with the objective psyche, he or she may also need help to understand the highly symbolic and mythological images that have been liberated. If, as Jung claims, the unconscious is indeed the repository for the psychological experience of all mankind, then we should not be surprised that the objective psyche communicates in an archaic language, a language that is permeated with the myths and symbols of mankind's past.

Jung further claims that the archetypal forms remain constantly in everyone's psyche, often lying dormant waiting for a stimulus and for liberation.

'Archetypes are like river-beds which dry up when the water deserts them, but which it can find again at any time. An archetype is like an old water-course along which the water of life has flowed for centuries, digging a deep channel for itself. The longer it has flowed in this channel the more likely it is that sooner or later the water will return to its old bed'.<sup>2</sup>

To give archetypal expression to something is to interact with both collective and historical images in such a way that the oppositions contained within the unconscious find expression. For Jung the unconscious is com-

---

<sup>1</sup> Monaco, P., Cinema and Society: France and Germany during the Twenties, (New York, 1976): p84

<sup>2</sup> C. W. 10: 395

posed almost entirely of oppositions, e.g. conscious/unconscious, thinking/intuition, light/dark, individual/collective, and the index of the Collected Works even contains a special index of oppositions.<sup>IV</sup> It is not the function of the archetypes to directly unite these opposites but rather to acknowledge that opposition does exist, and in so doing to bring them in a fresh state of creative tension with the rest of the psyche. Thus opposites are united but not integrated, and the Buddhist symbol of Yin and Yang is an example of light and darkness, male and female principles, being united but not integrated. They are one, yet the principal oppositions remain separate.

#### Yin and Yang



The dwarf Plan-ku, holds the Yin-Yang symbol. From: Mythology: an illustrated encyclopedia, Cavendish, R., editor, (London, 1980): p80

As all psychic imagery is to some extent archetypal so dreams, films, myths and other psychic events may have numinosity. As mentioned, this is the 'power' that is felt as the objective psyche expresses itself through the might of the archetype and its associated imagery. More literally, numinosity can be an experience of God. Somehow it is possible to get from contact with the unconscious a religious experience, or as Jung would more cautiously put, an experience of the image of God, the Imago Dei. As he comments,

'It would be a regrettable mistake if anybody should take my observations as a kind of proof of the existence of God. They only prove the existence of an archetypal God-image, which to my mind is the most we can assert about God psychologically'.<sup>1</sup>

To return briefly to film theory, Parker Tyler has written in his book The Magic and Myth of the Movies, that it is vital,

'...to conceive the supernatural fables of Hollywood as bona fide creative offerings, destined to be accepted as true or untrue representations of the orders of reality - part of such orders being of course the spiritual orders'.<sup>2</sup>

It would seem that there is a correspondence between Parker Tyler's concept of 'spiritual orders' and the Jungian Imago Dei, and a common understanding of numinosity seems to help validate this link. Parker Tyler proceeds to argue that for any manifestation of spirit to be accepted in a film there must also be a common audience presupposition concerning the validity of such spiritual events. Which is to say that there is an unconscious psychological need for spiritual or numinous experiences which to some extent films both express and gratify, 'In other words, some basic and common spirituality must exist to support belief in any manifestation of spirit, no matter how outrageous or symbolic in form'.<sup>3</sup>

However for Jung the psyche and its constituent parts, including the objective psyche, are not just symbolic but are real, and they form part of a categorised and analysable system whose effects can be repeatedly seen. Therefore on the subject of God he is able to write,

---

<sup>1</sup> C. W. 11:102

<sup>2</sup> Tyler, P., Magic and Myth of the Movies, (London, 1971): p57

<sup>3</sup> Tyler, P.: p89

'The idea of God is an absolutely necessary psychological function of an irrational nature, which has nothing whatever to do with the question of God's existence. The human intellect can never answer this question, still less give any proof of God. Moreover such proof is superfluous, for the idea of an all-powerful divine Being is present everywhere, unconsciously if not consciously, because it is an archetype'.<sup>1</sup>

So the question as to whether God exists or not is for Jung irrelevant. For him it is sufficient to say that an archetypal experience of the Imago Dei exists and characterises archetypal expression. This experience of the numinous is an important psychological event and it should not be surprising to find expressions of the objective psyche which are characterised by a religious nature. (The use of the term 'religion' presupposes that it is taken in the widest possible sense to include any experience of the divine whether this occurs within a world religion or not). In fact it is possible to say that any analysis of the archetypal which fails to take into account the numinous may be flawed, and flawed in quite a fundamental way.<sup>V</sup>

However Jung took this concept of the archetype even further. He felt that in the final analysis archetypes serve as the models or patterns for everything within the human realm. Thus all ideas creative, scientific, political, mathematical or whatever are archetypal, and the outer world, the world of the ectopsychic system, becomes a creation of the deep structures of the psyche, of archetypal forces and patterns. From this premise it would be expected to find the collective archetypal patterns of the unconscious clearly stamped onto the conscious world, and to restate once more this fundamental notion; the unconscious expresses itself only through conscious images and forms. Jung has commented on this and notes that,

---

<sup>1</sup> C. W. 7: 110

'All the most powerful ideas in history go back to archetypes. This is particularly true of religious ideas, but the central concepts of science, philosophy, and ethics are no exception to this rule.... For it is the function of consciousness not only to recognize and assimilate the external world through the gateway of the senses, but to translate into visible reality the world within us'.<sup>1</sup>

At this stage it is important to mention two of the most important archetypes named by Jung, the so-called contrasexual archetypes of anima and animus. He defines the anima as the inner figure of woman in man and the animus as the inner figure of man in woman, and in some ways these figures are quite alike. To start with both are archetypes and because of their contrasexual nature they can be seen as opposites and because they are archetypes they are regarded as being in a state of tension with ego-consciousness. In other words the inner anima, or woman in man, is in tension with his conscious masculine sexuality, but it is precisely because the anima and animus are archetypes that it would be naive to regard them as merely existing in a state of contrasexual tension. As already mentioned archetypes have a structuring potential, and the images that these archetypes clothe themselves with are termed 'psychopompi'. They are figures which guide the soul, or inner self, especially at times of initiation or personal crises, for example birth, death, weddings, adolescence, old age and during other rites of passage.<sup>VI</sup>

Because of their archetypal qualities the forms of anima and animus have found expression in many collective images. For example the anima is released in such figures as Aphrodite, Helen of Troy, and the animus can be recognised as Hercules and Romeo. However these figures can often assume a more symbolic form, and it is important to note that the anima has a dark and threatening aspect so she can find expression in the image of the

---

<sup>1</sup> C. W. 8:342

gorgon and the dragon as well as in such symbols as the moon and the fertility goddess. The animus may conversely appear as the sun, a lion or perhaps a sword, again all highly symbolic images. It is precisely because the archetype does adopt so many guises that it is difficult to understand and comprehend, and constant reference must be made to mythology and other expressions of the unconscious in an attempt to find new parallels and fresh contexts for the expression of these archetypes. When dealing with the collective expressions of the objective psyche it is only sensible to look for other expressions of these archetypes in the hope that they will help us to understand. This can be achieved by referring to a variety of myths with similar themes because, as Jung notes, the cores of all myths and religions are archetypal.

'In spite or perhaps because of its affinity with instinct, the archetype represents the authentic element of spirit, but a spirit which is not to be identified with the human intellect since it is the latter's spiritus rector. The essential content of all mythologies and all religions... is archetypal'.<sup>1</sup>

At this point it may be useful to have a summary of the key points concerning archetypal functioning.

### Summary

- 1) In the objective psyche are archetypes, these are the structuring potential for the psyche and evolve over a period of time. They are liberated at times of personal crisis and transition and operate in a compensatory fashion.
- 2) When the archetypal patterns are freed they assume the form of images and symbols, they are concerned with the uniting of opposites within the psyche.
- 3) All conscious events are, in the final analysis, archetypal and thus are expressions of the collective.

---

<sup>1</sup> C. W. 8: 406



THE SYMBOLIC FUNCTION

It is not only through the archetypes that the objective psyche communicates but, as has already been stressed, through many other conscious visual forms. One area identified by Jung for special study was the symbolic. He was interested in the way in which symbols could be regarded as unconscious communications, and it would be reasonable to claim that all communications from the unconscious have a symbolic attitude. This stress on the value of symbols was one of the many factors which led to his break with Freud. As Jung states in the quote below he differed with Freud both over the definition of symbols and their function within the psyche.

'Those conscious contents which give us a clue to the unconscious background are incorrectly called symbols by Freud. They are not symbols, however, since according to his theory they have merely the role of signs or symptoms of the subliminal processes. The true symbol differs essentially from this, and should be understood as an intuitive idea that cannot yet be formulated in any better way'.<sup>1</sup>

Thus the symbol comes from the unconscious and is a means of expressing a concept or truth that has been grasped by the intuitive part of the endopsychic system but has yet to find conscious expression. Parker Tyler has noted that films, as a collective product, may express symbolic truths and as such they illustrate insights which have been comprehended intuitively and which find their concrete cultural expression in films. 'Many modern movies illustrate the latter-day vestiges of very remote but serious beliefs of mankind that now have the appearance of mere symbolic fantasy'.<sup>2</sup> Jung also regards symbols and symbolic products as part of the objective psyche's self balancing system, and as already mentioned, it is the archetypes which regulate the psyche.

---

<sup>1</sup> C. W. 15: 105

<sup>2</sup> Tyler, P.: p91

Further, it may be that films as collective psychological expressions of symbols, have a role in this regulating process. Archetypes achieve this regulation of the psyche by making ego-consciousness aware of opposites in the psyche and the very act of this recognition unites these differences. As part of this regulation process the objective psyche liberates symbols, and these may be released in a dream, or virtually any creative art, including film making. These symbols function in what Jung has termed a 'compensatory fashion', as a result of this conscious cultural attitudes are balanced by opposite compensatory expressions from the unconscious. As he comments,

'From the activity of the unconscious there now emerges a new content, constellated by thesis and antithesis in equal measure and standing in a compensatory relation to both. It thus forms the middle ground on which opposites can be united'.<sup>1</sup>

Jung regards the whole process of symbolic compensatory regulation as so vital that he remains concerned for individuals, or cultures, who are no longer in contact with the symbolic dimensions of their lives. To ignore symbols is to ignore the collective aspects of the unconscious, and to ignore the unconscious is to live in bleak isolation.

'Anyone who has lost the historical symbols and cannot be satisfied with substitutes is certainly in a very difficult position today: before him there yawns the void, and he turns away from it in horror. What is worse, the vacuum gets filled with absurd political and social ideas, which one and all are distinguished by their spiritual bleakness'.<sup>2</sup>

The content of a symbol, that is what it means, is often far from clear, and it is precisely because it is a communication from the unconscious that its meaning remains shrouded in an essential mystery.<sup>VII</sup>

---

<sup>1</sup> C. W. 6: 825

<sup>2</sup> C. W. 9, I: 28

while at the same time it possesses universal imagery, and thus a symbol addresses itself to the needs of a specific individual or culture but does so in a universal language. If sufficiently analysed and reflected upon, symbols can be seen as aspects of images that control and which give order to human life, and their source can be traced to the archetypes, through which the symbol finds expression.

Monaco has suggested that film is, in effect, a symbolic communication from the unconscious and as such its collective appeal is due to a shared psychological and symbolic base. He claims that in films it is possible to recognise the expression of a shared cultural and psychological need. To translate this into the language of analytical psychology, films represent a compensatory communication, from the objective psyche, which functions as part of a collective unconscious psychological regulatory process. As he has noted,

'Film communicates by the elaboration of precise, symbolic visual material that creates both a mood and a story. The result is a medium whose primary appeal is psychological. And the psychology of the most popular movies must be collective... The symbolism of a popular movie must be such as to create the basis of a shared, collective psychological appeal to at least a portion of the mass audience'.<sup>1</sup>

While Monaco has every justification for claiming is that the 'psychology of the most popular movies must be collective', the situation is more complicated than this statement implies. For example the function of symbols in film is not to create 'both a mood and a story', rather they transcend the limitations and oppositions of the narrative<sup>VIII</sup> thereby helping to imbue it with a mythological dimension. Also the symbol is emphatically not a precise formulation but instead it is associated with

---

<sup>1</sup> Monaco, (1976): p75

the archetypes, and possesses an imprecise numinous quality which is essential to its function. Once robbed of this mystery the symbol ceases to have value and it has lost its symbolic power, and therefore there is a sense in which symbol, just like an archetype, is ultimately unknowable.

'A symbol loses its magical or, if you prefer, its redeeming power as soon as its liability to dissolve is recognized. To be effective, a symbol must be by its very nature unassailable. It must be the best possible expression of the prevailing world view, an unsurpassed container of meaning; it must be sufficiently remote from comprehension to resist all attempts of the critical intellect to break it down; and finally, its aesthetic form must appeal so convincingly to our feelings that no arguments can be raised against it on that score'.<sup>1</sup>

Thus there is a sense in which any analysis of a symbol is doomed to certain failure on at least two accounts. First a symbol can never be fully understood, and secondly the more a symbol is understood the less value it has for us.

So while the ultimate nature of a symbol must remain a mystery there are generalisations which can be made concerning it. For example the symbol is an intervention of the objective psyche to solve a problem of consciousness. So it is possible to speak of unifying symbols, these are symbols which bring together apparently disparate elements, and become living symbols which are intimately connected with our conscious situation. It is a consequence of this symbolic activity that symbols are not sterile, but very much alive and active parts of the psyche. As Jung comments, 'The symbol is thus a living body, corpus et anima; hence the "child" is such an apt formula for the symbol'.<sup>2</sup>

---

<sup>1</sup> C. W. 6:401

<sup>2</sup> C. W. 9,I: 291

In attempting to discover the meaning of a symbol, the symbol should be firmly placed in its archetypal context as a corrective or compensatory regulation from the objective psyche. Specific reference should also be made to the environment, that is the dream, myth or film, in which the symbol occurs, and there should be an attempt to view the symbol as part of a unified symbolic structure that operates within that environment. It should be possible with reference to historical, mythic and symbolic parallels to create a model within which a given symbol/symbolic structure can at least be partly understood. However it should always be remembered that the meaning of a symbol is liable to change and ultimately understanding of a symbol will remain incomplete. Despite this, with recourse to the mythological process, the relatively fixed meaning of many recurring archetypal symbols can be observed.

#### THE FUNCTION OF DREAMS

As mentioned one of the ways in which the unconscious images, symbols and archetypes may be seen and understood is through dream analysis. For Jung the dream is a manifestation of the unconscious and therefore it contains within its highly symbolic, and mythic images, a compensatory communication from the objective psyche. In this sense Freudian and Jungian schools are clearly differentiated. As Jung wrote,

'As against Freud's view that the dream is essentially a wish-fulfillment, I hold... that the dream is a spontaneous self-portrayal, in symbolic form, of the actual situation in the unconscious'.<sup>1</sup>

To once more juxtapose Jungian and film theory: Jarvie has commented in his book Cinema and Society, that,

---

<sup>1</sup> C. W. 8: 505

'... movies find their relationship to society in oblique symbolism. The most fruitful source of insight into an individual's latent concerns is the dream. One of the most striking characteristics of film is its relationship to the dream'.<sup>1</sup>

To return specifically to Jung, he later came to see dreams as active elements in the psyche. Rather than just indicating the situation in the unconscious, the dream provides the compensatory images and in so doing attempts to rectify any imbalance that there may be in the psyche, 'The dream rectifies the situation. It contributes the material that was lacking and thereby improves the patient's attitude. That is the reason we need dream-analysis in our therapy'.<sup>2</sup>

Basil Wright, like Jarvie cited above, draws parallels between the dream and film and he does so with specific reference to Jungian theory. Again, as with most writers cited, Wright's emphasis is on film as an expression of latent or unconscious needs and as such film is endowed with a compensatory function. For Wright, film is in some way connected to the objective psyche,

'If, as he (Jung) suggests, dreams are capable of arousing in individuals "not only the contents of personal conflicts but also manifestations of the collective unconscious", might not films, if only to a degree, have something of the same ability?'.<sup>3</sup>

While Jung accepted that compensation was the principal way in which the objective psyche operated he was also anxious to note that what is being compensated at any given time is not always apparent. Therefore great patience is required if dream images are to be decoded and understood. It is also worth noting that he felt dreams not only indicate the present

---

<sup>1</sup> Jarvie, I. C., Towards a Sociology of the Cinema, (London, 1970): p7

<sup>2</sup> C. W. 8: 482

<sup>3</sup> Wright: p9

situation of the unconscious but also show the way in which the psyche ought to develop, and so they have an anticipatory nature which assumes a highly symbolic form. As he notes below,

'The Snake in the first mandala dream was anticipatory, as is often the case when a figure personifying a certain aspect of the unconscious does or experiences something that the subject himself will experience later. The snake anticipates a circular movement in which the subject is going to be involved; i.e., something is taking place in the unconscious which is perceived as a circular movement, ...'.<sup>1</sup>

### The Uroboros

The snake or dragon consumes and recreates itself in a circular movement.

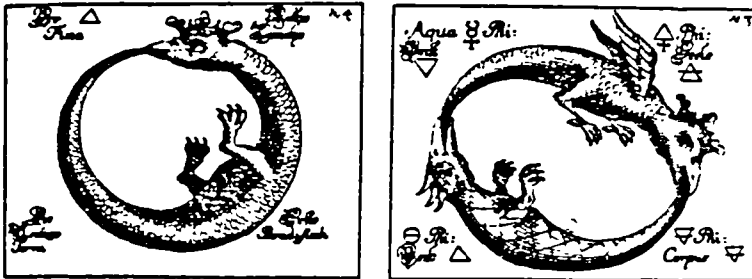

From: C. W. 12: 126 'Eleazar Uraltes chymisches Werk' (1760)

While acknowledging this anticipatory quality in dreams Jung also stresses that dreams should not be thought of as clear prophetic statements, rather they indicate in a very general way a path for the development of the psyche. Dreams can be thought of as anticipatory in much the same way that an artist's sketch anticipates the final painting, the final painting being fuller, in a more vivid colour and with the composition subtly changed.

While most dreams appear to have a constructive compensatory nature there are certain types of dreams which are destructive in their compensatory effects, and as such they accomplish their role in a most unpleasant, although necessary, fashion. These dreams may assume the quality of what

---

<sup>1</sup> C. W. 12: 129

Jung terms 'Big Dreams', which come to represent either major changes in an individual's life, or the close of a stage in psychological development.

'The "big" or "meaningful" dreams come from this deeper level (the unconscious). They reveal their significance - quite apart from the subjective impression they make - by their plastic form, which often has a poetic force and beauty. Such dreams occur mostly during the critical phases of life...'<sup>1</sup>

Whatever the specific nature of dreams their images are perhaps most aptly seen as the best possible expression of psychological facts, or truths which are latent in the unconscious.

'Dreams contain images and thought associations which we do not create with conscious intent. They arise spontaneously without our assistance... Therefore the dream is, properly speaking, a highly objective, natural product of the psyche, from which we might expect indications, or at least hints, about certain basic trends in the psychic process'.<sup>2</sup>

It would seem from this comment that Jung regards dreams as presenting an accurate picture of the unconscious, just as it is.

To a certain extent here is another point of contact between film and Jungian theory. Just as dreams give an impression of reality, which contains many symbolic-mythic and coded compensatory signals, so too film may have something of this quality. As already noted films contain symbols and myths, and they too operate as carriers of this psychological information in a compensatory way. In one sense films present a picture of conscious 'reality', in another sense films present a symbolic and mythic picture of an unconscious reality. As Wright comments,

'The magico-mythological element of the motion picture, as opposed to the scientific-technological aspect, involves a double aspect of reality. A film can give an impression of

---

<sup>1</sup> C. W. 8: 555

<sup>2</sup> C. W. 7: 210



actuality - a reality which we accept as being in line with our daily experience of the world. But a film can also give an impression of super-reality - the reality of one of those dreams whose circumstance we do not accept as part of our daily experience, but whose intensity seems to produce a conviction of reality superior to actuality itself. (Such<sup>1</sup> indeed must, in part, be the experience of the visionary)'.<sup>1</sup>

This inevitably raises the question of how films and dreams, which are both notoriously difficult to understand, can be comprehended.

Jung himself admits that the interpretation of a dream is a difficult task and he suggests that the analyst should approach the dreams with no preconceived ideas about what they might mean. From this basis the patient should be encouraged to make free associations with the dream images in an attempt to discover their personal meaning. However understanding the dream process is a multifaceted procedure, for the dream is not concerned with the intellect alone but with the totality of the psyche. As such, and as manifestations of the objective psyche, dreams have a collective symbolic and archetypal quality which can only be understood with reference to the appropriate historical and mythological parallels, and this is especially true for the so-called big dreams.

'Such reflections are unavoidable if one wants to understand the meaning of "big" dreams. They employ numerous mythological motifs that characterize the life of the hero, of that greater man who is semi-divine by nature. Here we find the dangerous adventures and ordeals such as occur in initiations. We meet dragons, helpful animals, and demons; also the Wise Old Man, the animal-man... they have to do with the realization of a part of the personality that has not yet<sup>2</sup> come into existence but is still in the process of becoming'.<sup>2</sup>

Perhaps the same method of mythological reinforcement could profitably be used in film analysis? If dreams and films are closely related then the

---

<sup>1</sup> Wright: p8

<sup>2</sup>C. W. 8: 558

method used by analytical psychology of mythological parallels, which reinforce the central myth theme, would seem a valid approach. Monaco, like Wright, has found resemblances between myth and film and in a sense both regard film as a culturally shared dream which, magically, transcends reality to super-reality in an expression of latent unconscious needs.

'Myth represents the reflection of a certain kind of thinking that creates a particular mode of being. This may be true of the cinema as well. It is not so much that the cinema creates a "reality lived," but rather that it transcends reality (quasi-magically) while maintaining a close connection to the pictorial accuracy often associated with reality'.<sup>1</sup>

Thus in attempting to understand these recurring archetypal forms and images in films and dreams the analyst should refer to that great storehouse of the archetypal, the myth, and to do so is to intuitively recognise the collective nature of these images. Finding expression in these dreams are not only an individual's present psychological needs and future development, but also the collective needs of mankind, of which the individual is in reality a microcosm. If an individual does possess a 'collective unconscious', or objective psyche, then that is truly larger than the individual psyche, and it should not be surprising that his dreams reflect both individual and collective needs. This is also in accord with the principles of opposition, compensation and regulation that have already been discussed. As Jung notes,

'...we have to go back to mythology, where the combination of snake or dragon with treasure and cave represents an ordeal in the life of the hero. Then it becomes clear that we are dealing with a collective emotion, a typical situation full of affect, which is not primarily a personal experience but becomes one only secondarily. Primarily it is a universally human problem which, because it has been overlooked subjectively, forces itself objectively upon the dreamer's consciousness'.<sup>2</sup>

---

<sup>1</sup> Monaco, P., (1980): p37

<sup>2</sup> C. W. 8: 555

At this juncture it may be helpful to summarise the key points concerning symbols and dreams.

### Summary

1. Symbols and dreams are communications from the objective psyche and are part of its regulating system.
2. Symbols are vital for a healthy psychic life, both individually and culturally.
3. Symbols can never be fully understood, to do so would destroy their 'magical' or redeeming qualities.
4. Any attempt to comprehend a symbol or a dream must involve placing it in its archetypal and mythic context.
5. Dreams and symbols function in a compensatory fashion, and dreams may have an additional anticipatory nature.
6. Dreams deal with collective emotions that become personal only secondarily.

### THE INDIVIDUATION PROCESS

So far in this very brief introduction to Jung's psychology, account has been taken of his personality theory, symbols, dreams and archetypes, and these have been shown as parts of an inter-related system. However there is one important concept which has not been examined, and it is particularly significant because it can be thought of as the concept which unifies analytical psychology; it is termed by Jung the 'individuation process'. The Critical Dictionary of Jungian Analysis commences its definition of individuation by describing it as, 'A person's becoming himself, whole, indivisible and distinct from other people or collective psychology (though also in relation to these)'.<sup>1</sup> This is a good basic definition, for the

---

<sup>1</sup> Critical Dictionary of Jungian Analysis, (London, 1986): p76

individuation process is about becoming a whole person, or if preferred, fully human, but there always exists a tension between the notions of individual and community. For a person individuality is asserted by the objective psyche from within, and at the same time by the community from without. However the shortcoming of the previous quote is that it gives no indication of what the individuation process involves or how it occurs.

It will be remembered that Jung postulated the existence of an archetypal core at the centre of the endopsychic system called the objective psyche, and this core has a structuring potential. He claims that if mankind becomes aware of this core and listens to its messages then the human psyche, and hence all human life, would be relatively free from problems. If only consciousness did not create so much noise and thereby intrude upon the inner life then the structuring potential, which contains the material for the individuation process, could be freely released. As he notes,

'We must be able to let things happen in the psyche. For us, this is an art of which most people know nothing. Consciousness is forever interfering, helping correcting and negating, never leaving the psychic processes to grow in peace. It would be simple enough, if only simplicity were not the most difficult of things'.<sup>1</sup>

Throughout Jung's life his psychology was concerned with ways of using consciousness to express the unconscious, and with the ways in which the unconscious makes itself known in myths, dreams, creativity, meditation, Eastern and Western religions, symbols, etcetera. He developed a therapeutic technique in which the client was encouraged to draw, paint, or write poetry in an effort to represent and discern the unconscious process

---

<sup>1</sup> C. W. 13: 20

of individuation, which runs throughout all humanity and which the conscious mind so easily, and with such detrimental effects, represses.

Even though the individuation process is a vital process for human life, there is a possibility that individuation may be misinterpreted as an elitist process only for a few gifted, creative individuals. Indeed Jung's study of Christ's individuation<sup>IX</sup> may have unwittingly contributed to this point of view. In fact individuation is available for everyone, although not all undertake to travel its demanding and treacherous path, and individuation is for all because it is a natural process - it is the way in which the psyche realises its full human and collective potential. As Jung has written,

'In so far as this process, as a rule, runs its course unconsciously as it has from time immemorial, and means no more than that the acorn becomes an oak, the calf a cow, and the child an adult. But if the individuation process is made conscious, consciousness must confront the unconscious and a balance between opposites must be found. As this is not possible through logic, one is dependent on symbols which make the irrational union of opposites possible. They are produced spontaneously by the unconscious and are amplified by the conscious mind'.<sup>1</sup>

The role of the individuation process is to cause the union of opposites, or rather to acknowledge the existence of opposition within the psyche and in so doing to unite this opposition. At the moment that this process of uniting occurs, the psyche liberates symbols of wholeness, of completion and balance. These images can manifest themselves in dreams, or in paintings or in any media which seems appropriate to the individual who is experiencing the pull towards individuation. Jung termed these images mandalas, and they often assume the form of a circle squared, or surrounded by a square, the circle being subdivided into regular divisions of four. (c.f. illustration below).

---

<sup>1</sup> C. W. 11: 755

Perhaps the most important opposition exists between ego-consciousness and the unconscious. The union of conscious and unconscious is so important that Jung termed it the 'Transcendent Function' and it represents the way in which, through individuation, the psyche transcends the immediate desires of ego-consciousness to embrace the collective. There is the danger that individuation could be thought of as no more than acceptance of one's own personal qualities - what it is that makes 'me' an individual. However Jung went to great lengths to indicate that this is not the case.

'Individualism means deliberately stressing and giving prominence to some supposed peculiarity, rather than to collective considerations and obligations. But individuation means precisely the better and more complete fulfilment of the collective qualities of the human being...'<sup>1</sup>

### The Mandala

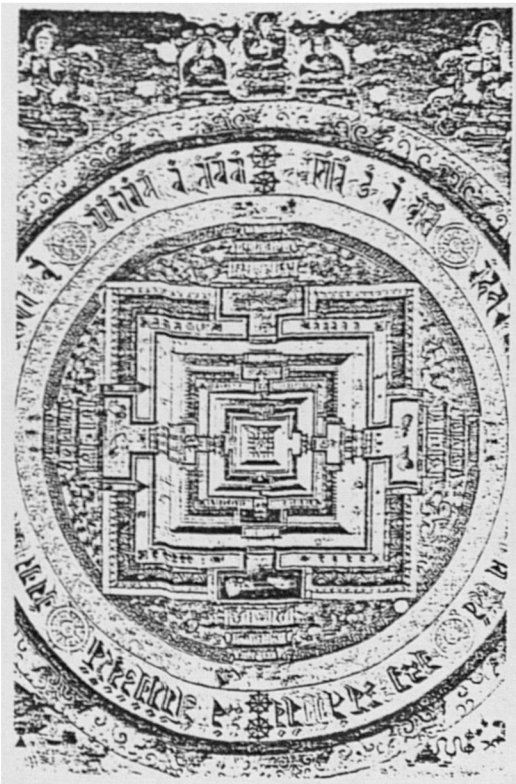

Kalachakra Mandala. From:  
The Kalachakra Tantra: rite of initiation, Gyatos, T. Translated Hopkins, J., (London, 1985): p80

---

<sup>1</sup> C. W. 7:267

However with this desire for the fulfillment of collective qualities come certain potential dangers. To accept the unconscious is to accept the shadow side, the repressed and evil aspect of the human psyche, and it also involves accepting the anima/animus, by realising that within each individual there is a strong contrasexual element that needs to be integrated with ego-consciousness. It is also to open oneself to an experience of the collective myths, fantasies, symbols of mankind, and to experience the numinosity of archetypal power. It is to accept that, temporarily, at least, ego-consciousness has lost control.

Individuation is not about becoming a perfect person but is about accepting the imperfections and oppositions that are latent in the psyche; and to accept the shadow and the anima is to accept that the psyche is not perfect,

...

'... there is no light without shadow and no psychic wholeness without imperfection. To round itself out, life calls not for perfection but for completeness; and for this the "thorn in the flesh" is needed, the suffering of defects without which there is no progress and no ascent'.<sup>1</sup>

The dangers of the individuation process are twofold, first there may be a narcissistic preoccupation with the psyche. Secondly, and more importantly, the trauma that an individual undergoes while being exposed to the unconscious may result in anti-social behaviour or even psychotic breakdown. This indicates the importance of the analyst's role, as someone must be able to understand and interpret the wealth of symbolic and mythic material that is freed as the unconscious is embraced.

If the analyst is to understand the visual communications of the unconscious, and to understand how the individuation process is expressed, then

---

<sup>1</sup> C. W. 12: 208

it is vital to have, as the clinical psychiatrist has, constant recourse to myths, symbols, folklore and to the many other ways in which the objective psyche makes itself known. For it is only by creating mythological parallels that the highly coded and symbolic communications of the unconscious can be understood, as Jung notes,

'... I consider it impossible for anyone without knowledge of mythology and folklore and without some understanding of the psychology of primitives and of comparative religion to grasp the essence of the individuation process, which, according to all we know, lies at the base of psychological compensation'.<sup>1</sup>

There is one further and very important point that is implicit in all that has been said about the individuation process. Individuation is something that happens on a cultural scale as well as to the individual. If the individual is really a microcosm of humankind then it should be expected that a change so radical as individuation affects not only himself but the entire culture. According to this model cultures individuate, they become aware of the diversity and opposition within them, and they come to accept their shared collective unconscious qualities.

'Every advance in culture is, psychologically, an extension of consciousness, a coming to consciousness that can take place only through discrimination. Therefore an advance always begins with individuation, that is to say with the individual, conscious of his isolation, cutting a new path through hitherto untrodden territory... If he succeeds in giving collective validity to his widened consciousness, he creates a tension of opposites that provides the stimulation which culture needs for its further progress'.<sup>2</sup>

This chapter has sought to find some points of contact between the analytical psychology of C. G. Jung and film theory. While some points of correspondence have been found, this amounts to little more than finding points of contact between the two theoretical systems. There are two

---

<sup>1</sup> C. W. 8: 553

<sup>2</sup> C. W. 8: 111



logical developments from this position. The first is to apply Jungian theory in a film analysis. Derived from this is a second step which is the development and testing of a model designed to overcome any difficulties encountered in the analysis. The model should serve to deepen the understanding and application of the psychological theory and thereby reveal deeper and previously unexplored levels of the film.

CHAPTER TWO NOTES

- I. c.f. C. W. 7: 103n
- II. c.f. page 57
- III. c.f., Dictionary of Analytical Psychology: p26
- IV. There are some points of contact between Jung's notion of opposition and Levi-Strauss' concept of binary opposition. Both regard opposites as fundamental to the structure of myth but for Levi-Strauss these oppositions serve to pull apart the myth. [c.f. Levi-Strauss, C., Mythologiques: Le cru et le cuit, (Paris, 1964)].
- V. c.f. Jaffé, A., The Myth of Meaning in the Work of C. G. Jung, (Zurich, 1983): p52
- VI. For a detailed anthropological account of what constitutes a 'rite of passage' c.f. Gennep, A. V., Rites of Passage, Translated Vizedom, M. B., Caffee, G. L., (London, 1960).
- VII. The notion of mystery in this context is not unrelated to the concept of numinosity explored above, c.f. p61
- VIII. c.f. Chapter Six, The Symbolic Search
- IX. C. W. 11: 296-448

Chapter Three

Tightrope

The Detective and His Shadow

## INTRODUCTION

The aim of this chapter is to apply the general theoretical framework of analytical psychology that has been detailed in the previous two chapters. Already in the thesis points of contact have been found between Jungian psychological theory and films, and it is now proposed to present a Jungian psychological analysis of one of the films that was briefly mentioned in Chapter One. This film is Tightrope (Dir. Richard Tuggle, Warner, 1984) and it will be shown that beneath the surface narrative of Tightrope there exists a complicated psychological and mythological framework.

The chapter will start with a synopsis of the plot and then progress to examine the psychological nature of the characters in Tightrope, special reference will be made to the relationship between the detective and the criminal. This relationship will be seen as integral to the detective's individuation process, although no reference will be made to the latter and more complex developments of individuation, such as the anima and mana-personality stages.<sup>1</sup> Underneath this surface of character and narrative, the analysis will reveal a series of mythological and archetypal patterns. The analysis moves between film, psychology, and mythology using each of these elements to inform about the other. This presents a diverse, yet unified, structure, as Hillman comments,

'We seek to reflect back and forth between the two, myth and psyche, using them to provide insights for each other, preventing either from being taken on its own terms only'.<sup>1</sup>

Following this methodology constant reference is made not only to the film, but also to the mythology and psychology which lies beneath the film, and both these elements are used to inform about the film's images.

---

<sup>1</sup> Hillman, J., The Dream and the Underworld, (New York, 1979): p24

Perhaps at this stage it is wise to sound a note of caution. The following analysis is not a hunt for archetypes and symbols, but it explores the images of the film letting, these suggest their own archetypal and mythological connections. With these words of caution in mind it seems appropriate to progress to the film itself.

### PLOT SYNOPSIS

The plot of the film is on the surface very simple. A series of murders are committed, each victim is a prostitute and is tied with handcuffs and red ribbon before being raped and then strangled. The detective Wes Bloch is in charge of the investigation, however, as the film progresses he gradually becomes more and more involved with the murders, for each prostitute that he visits, both professionally and privately, is murdered. During this time Bloch meets Beryl, who is a woman's self defence tutor, and she begins to provide for him a sense of stability in the midst of the chaos of his investigation. Eventually Bloch succeeds in discovering the criminal, who turns out to be an ex-policeman. In the final sequence of the film the murderer is trapped and after a lengthy chase Bloch captures him and in the ensuing struggle the murderer falls under a moving train and is killed.

### THE FILM'S CONTEXT

The opening shot of the film provides the context for the rest of the imagery. This initial shot is at night, and the camera is flying over the city. It crosses a wide river and gradually moves over the city lights. The sound track is filled with seedy jazz music, which is later used in the film to characterise the underworld of prostitution. Thus the nocturnal imagery for the film is established, as the murders in the film are all

committed at night and Bloch's trips to visit the prostitutes of New Orleans are also confined to the night. This opening shot, is mirrored by the final shot of the film which is also a view of the city at night. From beginning to end the film is wrapped in darkness. Intermittently it returns to daylight for some of Bloch's work in the police station and at home, but as soon as he revisits the prostitutes then the film is once more plunged into the murky depths of the night-like underworld.

In mythological terms this is perhaps a representation of the underworld of Hades, or hell and the film depicts murder and perverted sexual acts as belonging to this realm. In psychological terms it seems to represent the shadow of the psyche, which is often characterised by negative and destructive imagery. (This concept of the shadow will be explored in detail below). It is therefore no surprise that after the initial shot of the film there is a sequence in which a female prostitute is murdered. The sequence starts in a dark, night-time street, the lighting is very low key and this emphasises the underworld, threatening aspects of the killer. However, before the murder and rape are committed the scene is cut to show Bloch in a daylight street, playing with his children and befriending a stray dog.

From these opening moments an opposition is established. On the one hand there is the night-time world of prostitution and crime, and balanced against this is the daytime world of the detective's family and of regular police investigation. To simplify, the daytime world represents the 'normal' or 'good' aspects of Bloch's life, and in psychological terms these can be thought of as belonging to ego-consciousness. However in contrast to this is the night-time world, which represents the 'evil' or repressed shadow world of Bloch's unconscious. The only person who moves

between these two worlds is Bloch, which does seem to suggest that he has an affinity with them both. At home he is a father and lover of animals, having four dogs as pets, yet in the underworld he moves from prostitute to prostitute in his search for the killer and also on his personal sexual search. This duality is the prerogative of Bloch, who remains always alone. At home he has no wife, and at work he does not have a partner. Whether he is in the daylight world or in the underworld he remains isolated.

#### BLOCH'S PERSONA

Associated with the daylight world of ego-consciousness is Bloch's persona. It will be remembered that the persona is the outer mask that is worn to face the world. In other words, it is a necessary image of oneself behind which it is possible to hide, and Bloch seems to identify strongly with his persona. As mentioned above he is essentially a loner. This is of course part of the stereo-typical persona for the detective, and in Tight-rope it is combined with an almost fanatical loyalty to the work of detection, although not necessarily to the police force. Again this emphasises Bloch's isolated nature, for while he does work for a police department, he only occasionally uses his colleagues, and remains essentially by himself.

Also associated with Bloch's persona are his police handcuffs. Throughout the film handcuffs are used to symbolise both policemen and control. On the one hand they indicate his persona role as a policeman yet on the other they show his attachment to the underworld and to the shadow-criminal, as both Bloch and the killer use handcuffs during sex with the prostitutes. So there is a sense in which the outer image of the persona pre-figures the inner image of the shadow.

It is necessary for Bloch to realise this, because if psychological growth is to be achieved then not only is it important to have a strong persona, but it is also vital to have the capacity for introspection. Without this capacity for an inner life the persona remains in a stark isolation and the shadow becomes suppressed. This carries with it its own set of dangers, and as Jung commented,

'Mere suppression of the shadow is as little of a remedy as beheading would be for a headache. To destroy a man's morality does not help either, because it would kill his better self, without which even the shadow makes no sense. The reconciliation of these opposites is a major problem, and even in antiquity it bothered certain minds'.<sup>1</sup>

So Bloch's task can be thought of as twofold. First he must pass the persona phase and secondly he must accept his shadow. This will result in the expansion of ego-consciousness and the recognition that the psyche does possess collective qualities. It may also lead to relationship, for the detective no longer sees himself as an isolated individual but as a collective person. This process, which equates with the early stages of individuation, can be seen in Tightrope, and it is explored in detail above. At present it is sufficient to note that Bloch's awareness of his shadow occurs at the same time as his new relationship with Beryl.

The danger in this necessary introspective attitude, is that Bloch may get drawn into the shadowy underworld of the unconscious, a world that like his mythological ancestors Theseus and Pirithous, he may be unable to return from. Yet it is to this world that the shadow calls him, and it is to this call that Bloch responds. That Bloch is called into the underworld is evident both in his professional duties as a policeman and in his personal sexual life. (Although as will be seen these two elements are inter-linked). Bloch's sexual life not only involves him in visiting the prostitutes whom he interviews as a policeman, but also includes various forms of

---

<sup>1</sup> C. W. 11: 133



perverted sex, for example the use of handcuffs, and this sexual perversion also indicates an association with the underworld. As Hillman comments,

'So, Heraclitus, as one psychologist to another, across the centuries I read you as saying that for this troublesome distinction between emotion and soul, between the perspective of vitality (Dionysos) and the perspective of the psyche (Hades), sexual fantasy holds a secret... The Hades within Dionysos says that there is an invisible meaning in sexual acts, a significance for soul in the phallic parade, that all our life force, including the polymorphous and pornographic desires of the psyche, refer to the underworld of images'.<sup>1</sup>

It is this that Bloch has to recognise, that all life forces refer to the underworld of the psyche and that these must be eventually accepted and integrated into ego-consciousness.

#### Shadow and Persona

At this point it is important to explicitly state that within the mythology of Tightrope the criminal can be regarded as an outer personification of the detective's inner shadow. Once this is recognised it becomes clear that the detective is not only on an outer search to discover the murderer of the prostitutes, but he is also on an inner search to discover and to recognise and accept his shadow. Therefore there is a sense in which, for the detective, the inner and outer worlds are one.

In the first chapter of this thesis the exploration of the relationship between the detective and the shadow was started. However for the sake of completeness and clarity some of what was stated in these chapters will be repeated here, as this information relates to, and came from, Tightrope.

---

<sup>1</sup> Hillman, (New York, 1979): p44-45

There are several points in the film when the affinity between the detective and the criminal becomes clear. Or, to use the language of analytical psychology, it is possible to see that the persona of the detective conceals beneath it the shadow of the criminal.

In the first of these instances the detective Bloch is shown talking to a criminal psychiatrist who comments,

'Once you started going after him you became closer to him than anyone else. There's a darkness inside all of us Wes, you, me and the man down the street. Some of us have it under control, some act it out, the rest of us try to walk a tightrope between the two'.

#### Tightrope

This insight is reinforced by one of the characters in the film who remarks to Bloch of the killer, 'He said you were just like him'. It is interesting that this sequence with the psychiatrist follows one in which Bloch falls asleep clutching a photograph of himself and his wife on their wedding day. It is almost as though he is holding on to an image, or illusion of the past instead of acknowledging his own shadow qualities in the present.

Maybe this lack of awareness about his shadow is why his wife left him, however the viewer can only conjecture on this point. But the following dialogue between Beryl and Wes Bloch seems to hint that this was the reason for his wife's departure. (Again this was also cited in Chapter One).

Beryl: "Do you investigate many sexual crimes?"  
 Bloch: "Why?"  
 Beryl: "Just wondered if they'd affected you"  
 Bloch: "They did make me want to treat my wife a little more tenderly"  
 Beryl: "How did she respond?"  
 Bloch: "She said she wasn't interested in tenderness..."

#### Tightrope

The film also makes it clear that Bloch only became involved with the underworld of prostitution after his wife left him. This is evident when

he remarks to Beryl, about a prostitute whom he recognises in the street, 'I only made those sort of friends after my wife left'. It seems that in psychological terms Bloch has not yet recognised what parts of his psyche belong to ego-consciousness and what parts are projections from his objective psyche. He has not yet recognised that the shadow criminal is in fact part of himself. As Jung has commented,

'Again, the view that good and evil are spiritual forces outside us, and that man is caught in the conflict between them, is more bearable by far than the insight that the opposites are the ineradicable and indispensable pre-conditions of all psychic life, so much so that life itself is guilt'.<sup>1</sup>

Later in the film the association between Bloch and his shadow is made more explicit. In this sequence Bloch dreams that a black masked figure attempts to strangle Beryl, his girl friend. After a struggle, she manages to pull the mask off to reveal Bloch's own face, and at this point he wakes up sweating with fear, and this seems to make it clear that the shadow is a projection of the negative aspects to the detective's psyche. Just as the detective wears his persona as a mask to the outer world, so too the shadow wears a mask, and it is this which Bloch must learn to recognise if he is to accept his shadow side. In Tightrope the shadow quite literally assumes a variety of masks including a black mask, a grotesque mardi-gras mask, and a clown's make up, and it is almost as though by this act the shadow is parodying the persona of the detective.

It is also clear in the film that Bloch is afraid of his shadow. First the shadow represents the opposite of all that his persona and professional life stand for. The detective is concerned with law and order, while the shadow personifies the opposite of these qualities. Again in the sequence

---

<sup>1</sup> C. W. 14: 206

mentioned above, Bloch wakes up in fear, fear of what it is impossible to be sure, but as his dream was about himself as the shadow-criminal it seems reasonable to assume that it is this that worried him. Further supporting the interpretation that Bloch is indeed worried about his own shadow side, is the following conversation with Beryl,

Beryl: "I'd like to find out what's underneath the front you put on".

Bloch: "Maybe you wouldn't like what you find".

Tightrope

The message seems to be that Bloch has not yet come to terms with his own shadow, and perhaps it is this which makes him unable to form close relationships outside of his immediate family.

It is here in over identification with the persona and a refusal to accept his shadow that the danger for Bloch exists. For by identifying with the persona the inner world is ignored. But rather than vanishing, the inner world grows in strength; like water behind a dam it becomes fuller and fuller until one day it will overflow its banks, and flood into ego-consciousness, causing possible disaster. (In psychological terms this is a psychoneurosis).

That Bloch is overly identifying with his persona is evident when instead of spending time with his children he abandons them to start the murder investigation. Again, in the middle of the film, instead of spending time with Beryl, he quickly leaves her to return to his police work, and to the underworld. Here in the darkness he thinks himself safe, as one of the prostitutes comments, 'You can't ever get close to a cop'. Yet it is here that he is at his closest to the shadow, and on one occasion the shadow even watches him having sex with one of the prostitutes. Contrary to what he thinks, Bloch's real safety exists in the daylight world and in a rela-

tionship with Beryl, and in the film's imagery this is shown by placing Beryl almost exclusively in daylight settings. This puts her in the position of a compensatory opposite to the prostitutes who are seen in daylight only as corpses. It is almost as though, like some underground monster, they cannot survive in the rays of the sun, whereas Beryl belongs exclusively to this diurnal world.

The film is showing the complex psychological dialogue that takes place between ego-consciousness and the shadow. Bloch is faced with a dilemma: either he can succumb to the enticements of the underworld, or he can return to the daylight world having accepted his shadow, and in so doing having prepared for his relationship with Beryl.

That Bloch is in fact attracted to the underworld, is gradually revealed throughout the narrative. Initially the view of the film is presented with the image of Bloch as a model policeman. He responds quickly to a call for him to come to the police station, and yet he also spends time at home playing with his children. He is apparently as concerned about his family life as his work, yet even here the speed at which he goes to work, pausing to say only the briefest of goodbyes, hints that his devotion to duty is overly zealous.

The suspicion that behind this exterior of devotion lies something corrupt, is confirmed when Bloch is shown about to have oral sex with the female partner of the first murdered prostitute. It is interesting to note that Bloch accidentally leaves behind his tie, which in a symbolic way seems to show how Bloch is bonded, or tied, to the underworld. As both the narrative and the murder investigation unfold, Bloch visits more and more prostitutes, and he becomes so involved with the prostitutes and the murder

enquiry that the viewer is tempted to think that perhaps the murderer is Bloch. However by the end of the film Bloch is able to confront the shadow-killer, and it becomes clear that Bloch is not the murderer after all.

The final confrontation between Bloch and the criminal takes place at night. This whole sequence is given a highly mythological, and almost cosmological atmosphere as bolts of lightning and thunder explode in the sky. This is reminiscent of a scene near the beginning of the film where one of Bloch's fellow police officers remarks to him, while looking at a new moon, 'Do ya thing it brings out the crazies?', to which Bloch replies, 'Yeh. Always'. Both of these sequences have a curiously overt mythological tone to them, which sets them apart from the other narrative elements. Coming as they do, one at the beginning of the film, the other at the end they enfold the narrative of the film, which seems to support the view that Tightrope has a pronounced mythological element.

This battle between the detective and the killer takes place in an atmosphere that is charged with the electricity of the sky. In this sequence the detective chases the intruder through a graveyard and as he physically wrestles with the killer, Bloch pushes him under a moving train. Throughout the earlier part of this sequence, Bloch is kept in a spot light from an aerial helicopter while the shadow-killer tries to hide himself in the darkness of the graves.

Seemingly the killer is still trying to hide in the shadows of the underworld, after all Hades is the god of the dead, so it is perhaps appropriate that the killer should try to conceal himself amongst the graves. But even here, in the domain of Hades, the detective is apparently protected by the mandala-like circle of white light cast by the helicopter. Bloch in the

underworld is surrounded by light, this is noticeably different to the earlier images in the film, where he is completely immersed in its darkness.

Much as the circular light from the new moon initiated the investigation so the circular light from the helicopter's search beam apparently closes it. Both of these seem to be symbolic moments in the film, one indicating the start of the detective's quest and the other heralding its closure.

After Bloch has pushed the killer under the train, in other words when he is no longer in fear of his shadow, he is able to leave the body of the criminal behind, and rather than going down to the station to fill out a series of reports he is able to just walk into the night time city with Beryl. In fact this picture of Bloch and Beryl arm in arm, forms the final image of the film, from here the camera pulls back into the night sky to finish the film in the way in which it started, with a view of the nocturnal city. It seems as though the detective has accepted that he like everyone else has a shadow side, and this recognition enables him to continue his relationship with Beryl.

What follows, in summary form, is the sequence of events which represent the psychological transformation of Bloch.

- |                             |  |
|-----------------------------|--|
| 1. Bloch's wife leaves him  | He enters the underworld   |
| 2. First murder             | Becomes involved with the case   |
| 3. Following murders        | Becomes entangled with the underworld  |
| 4. Bloch meets Beryl        | Bloch is forced to look beneath his persona, and begins to accept the shadow |
| 5. Final murder             | Bloch is able to solve the case and hence regain control over his psyche     |
| 6. Destroys shadow-criminal | Bloch is able to leave the underworld with Beryl                             |

Thus in the circular construction of the film a stability is established, before the film started, Bloch had a wife and two children, and now at the end of the film the situation is almost the same. What has changed is that now Bloch has apparently come to terms with at least some of the darker side of his own psyche.

### ILLUSION

At this point, having discussed the images of the archetypes persona and shadow in Tightrope, it now seems appropriate to look deeper into the film's mythology. This chapter will now examine two important mythological motifs for the film, these are the illusion motif and the binding motif.

Occurring throughout the film is the idea that both murder and sex are illusory. For example, none of the murders was ever shown on screen, and there is a sense in which they are illusions, after all the viewer never actually sees them happening. Similarly, with the prostitutes, the actual sexual act is never shown, all that the viewer sees is the prelude to sex. So, like the murders, by their absence from the film, they assume an illusory quality. The prostitutes also sell illusory sex, including oral sex and hand sex, and their role in the film is to provide illusory sex and be the victims of illusory killings. In a way, they do not have the status of characters but are rather relegated within the film to the level of functionaries. They are identified by the particular sexual act that they perform, in other words, they have become totally identified with their personas and as such remain entrapped within the underworld context. The illusory, or shadowy, qualities, of both the murders and the sexual acts also seems to support the idea that Bloch is on a search for his shadow.



The functionary, and illusory, prostitutes are in sharp contrast to the other woman in the film, Beryl. Beryl, unlike the prostitutes lives in the daylight world, where she has a job teaching a woman's self-defence class, and so by doing this job she, like Bloch, is associated with the shadow side of the psyche.

The strongest contrast between Beryl and the prostitutes, exists in the way in which Bloch treats them sexually. With the prostitutes Bloch has whatever form of sex that they are offering, which may include bondage, using handcuffs and once he has had sex he is then able to leave the prostitute behind. (Even if he does later have to return to a different prostitute for a different service). These sexual practices are in contrast to the way in which he treats Beryl. The first time that Beryl and Bloch make love, Beryl picks up a pair of handcuffs that are beside the bed. Bloch explains that he only uses them when he needs control, and when he feels threatened, as Beryl comments, 'With these no one can get to you, eh?'. After this she, in an almost sacrificial gesture, offers her hands to be handcuffed by Bloch. Perhaps she is also informing Bloch that he has reason to feel threatened. Whatever, Bloch refuses to handcuff her as apparently she is not to be subjected to the same sort of illusory sexual control that the prostitutes are placed under.

This is in contrast to an earlier scene when Bloch and Beryl are both using the same large exercise machine. Here the imagery is given a highly sexual, although comical tone, with the close ups of interlocking levers, thrusting pistons, and synchronised movements between Beryl and Bloch. What is important is that, at this stage in their relationship, the sexual imagery is only illusory and mechanical, and as such in tone it properly belongs to the underground image world of the prostitutes. It is partly in recognition

of the fact that sex with 'real' women can not be illusory and mechanical that Bloch declines to use the handcuffs.

However Bloch still seems afraid, but of what the viewer can not be sure. Perhaps he is aware that real sex, with a real woman, involves a degree of commitment and trust that he does not have to have, and indeed is unable to have, with the prostitutes. The prostitutes are almost like sex machines, not unlike the exercise machine used by Bloch and Beryl, whereas, in contrast, Beryl is a person, and in making love to her he will have to let her past his persona and trust her with his whole self.

So it can be seen that making love to Beryl is for Bloch, almost an initiatory ritual, in which he accepts his shadow side and is therefore able to completely trust someone, no matter how imperfect he may still feel. In her willingness to have sex with Bloch, Beryl is both affirming and forcing Bloch to accept his shadow side, and it is shortly after this that Bloch has the dream where he is the shadow killer. It is with this insight that Bloch is then able to swiftly solve the case, and face the shadow-criminal.

#### THE UNDERLYING MYTHOLOGICAL THEME: BINDING

Part of the methodology of analytical psychology involves the uncovering of mythological parallels to the images under consideration. This enables the analyst to reflect between image, myth and psychology letting them inform about the other. To some extent this has been happening throughout the chapter, for example the underworld of crime has been seen as similar to the mythological underworld, which is the domain of Hades. However there is one theme in particular for which it may prove useful to examine a mythological parallel, and this is the binding, or bondage theme.

The image of binding is of central importance throughout the film, as it seems to act as a metaphor for Bloch's need for control. In a situation where Bloch feels threatened then he, like the shadow-criminal, handcuffs his sexual partner. However, when he thinks he does not need, or is unable to have, control, then his sexual practices return to normal, as when he makes love to Beryl.

When looking at mythological parallels to this image the Scandinavian myth of Tyr stands out as being particularly relevant. In this myth an animal, called the Fenris Wolf, is threatening the lives of the gods. The only hope that they can see is to find some way of tying up the wolf. Eventually a harmless looking magic cord is found and the Fenris Wolf agrees to let himself be bound round the neck, but only on the condition that Tyr puts a hand in the wolf's mouth. Tyr does this, and as the wolf is killed, Tyr loses his hand.

Branson has commented on this myth and notes that 'BINDING thus becomes important in Northern symbolism. In a way of initiation, men attending certain assemblies were bound and thus humbled for the occasion',<sup>1</sup> and here what is significant is the mythological insight that binding can be a form of initiation. For Bloch almost the opposite is true, or rather binding initiates him into the underworld and not binding returns him to the 'normal' world. This insight is supported by the film, as once Bloch has had sex with Beryl without using the handcuffs, he does not recommence his sexual visits to the prostitutes. The reason for this is that he has been initiated out of the underworld.

---

<sup>1</sup> Branson, C., Howard Hawkes; A Jungian Study, (Los Angeles, 1987): p42

Another point of correspondence between the Frenis Wolf myth and Tightrope is the severed hand. In the Frenis Wolf myth it is Tyr who loses his hand, but in Tightrope it is the shadow-criminal who has his arm severed. This happens in the closing moments of the film, when Bloch pushes the body of the killer under the train and the arm is severed from the body, still grasping Bloch's throat. It is also interesting to note that just as the Frenis Wolf was strangled by the magic cord, so too the killer in Tightrope strangles his victims.

To some extent both Tightrope and the myth of Tyr seem to deal with initiation and the shadow. In Tightrope Bloch is first initiated into the underworld of the unconscious, and there by virtue of his struggle with the shadow, he assimilates it into ego-consciousness. In the film this re-initiation or return to ego-consciousness is symbolised by the killing of the shadow figure and the establishment of the relationship with Beryl.

#### CONCLUSION

This analysis has used analytical psychology as a method for analysing film. This has been most notable in revealing the criminal to be a projection and personification of the detective's shadow. It has also been shown that the film contains concealed mythological references and also possesses a hidden structure of symbolic transformation. (This being Bloch's initiation).

A logical extension of this analysis is to develop a more systematic approach for applying the psychology. This would allow a clearer distinction to be made between the archetypal pattern, image, myth, symbol and psychological theory, and in turn this would enable a clearer exposition

of the film's mythological and psychological insights. In response to this now identified need, such a model will be presented in the following chapters. This model, along with additional psychological theory, will be applied and tested as the thesis progresses, and consequently what follows in the subsequent chapter is a further investigation into the central area of archetypal theory, from which a suitable model for applying analytical psychology to film analysis is derived.

CHAPTER THREE NOTE

- I. Once sufficient theory has been amassed then the later stages of the individuation process will be applied, c.f. Chapter Five, Blade Runner: p158, Chapter Seven, Individuation and the Detective: p184, Part Three passim.

PART TWO

THE MODEL:

A THEORETICAL SYSTEM FOR THE APPLICATION OF  
C. G. JUNG'S ANALYTICAL PSYCHOLOGY TO FILM ANALYSIS

Chapter Four

The Origins of the Archetype



## INTRODUCTION

This chapter is concerned with one specific area of analytical psychology; the theory of the archetype. This theory will be presented in four main sections. The first of the sections examines the development of Jung's ideas and seeks to explore his changing understanding of what an archetype is, and this includes a brief excursion into what causes an archetype to occur. The second section is a critique of archetypal theory by four critics: Hobson, Glover, Fordham and Dry. Their arguments are presented, and the validity of their criticisms as they relate to the archetypal hypothesis is evaluated. The third section is concerned with how it is possible to order or structure archetypes. Three possible methods are discussed and a preferred method is selected. The fourth and final section is the creation of an original model for the application of analytical psychology to the analysis of images. This model draws on the theory established in this and the preceding chapters, representing it in a fashion which is more suited to practical analysis, and is followed by a brief examination, or overview, of the model's operation. In the next chapter the model is further explored and tested by using it to examine the themes, myths, symbols and archetypes in the film Blade Runner (Dir. R. Scott, Columbia, 1982) and to locate all these areas within the context of analytical psychology.

ARCHETYPES - A DEFINITION OF THE TERM AND THE DEVELOPMENT OF THE  
HYPOTHESIS

Before embarking on an exploration of Jung's definition of the archetype it may be helpful to briefly examine a few precursors to his theory of the archetypal. These precursors are principally concerned with theories of innate structuring, or organising, potentials which were thought to be inherent in the universe. Plato conceived of a system in which 'original ideas', existing before the world was created, dwelt in the minds of the gods, and from those 'ideas' came all matters and reason.<sup>I</sup> These ideas can be regarded as collective in that they contain within them 'common qualities', thus the 'original idea' 'dog' has many shared 'common qualities' with all other dogs. These 'original ideas' are archetypal in that they provide the basic ordering system for the universe. In the eighteenth century Kant conceived of a series of innate fundamental categories, within an a priori schema, by which the world could be organised. It is interesting that these categories are dynamic and enter into the constitutions and composition of their material, much as an archetype may mould its subject. As Kant argues,

'First, then, if we have a proposition which in being thought is thought as NECESSARY, it is an A PRIORI judgement; .... Secondly, experience never confers on its judgements true or strict, but only assumed and comparative UNIVERSALITY, through induction'.<sup>1</sup>

The important points are that these categories are necessary and that they assume a 'comparative universality'. Finally in the nineteenth century Schopenhauer wrote about a system of prototypes, which he regarded as the original and unchanging form of all things. That he influenced Jung can be seen constantly in Jung's writings.<sup>II</sup>

---

<sup>1</sup> Kant, I., Critique of Pure Reason, Translated Smith, N. K., (London, 1929),  
B4

In trying to define exactly what is meant by the term archetype, it seems important to have some understanding of how Jung's thoughts in this area developed. As his understanding of what was meant by an archetype, or archetypes, evolved over the period 1912 to 1919, so this investigation into the archetypal will commence with his thought in 1912.

The archetypal hypothesis was initially formed from self analysis and from therapeutic work with the principally psychotic patients at Burgholzli Hospital. It seemed to Jung that the images produced by the patients, as well as the images in his own dreams, fell into relatively fixed groups or patterns. Further these patterns seemed to correspond to similar patterns in myths, fairystories, legends, etceter, and this material which was the product of so called 'spontaneous image' creations, did not seem to originate solely from the individual but, as Samuels notes, seemed to,

'... reflect universal modes of human experience and behaviour. Jung designated these Primordial Images using this term from 1912 onwards, in spite of numerous changes and modifications in the theory'.<sup>1</sup>

Jung also satisfied himself that no theory of human migration could adequately explain the apparently recurring patterns and motifs which appear transculturally and transhistorically.

'These fantasy-images undoubtedly have their closest analogues in mythological types. We must therefore assume that they correspond to certain collective (and not personal) structural elements of the human psyche in general, and, like the morphological elements of the human body, are inherited. Although tradition and transmission by migration certainly play a part, there are, as we have said, very many cases that cannot be accounted for in this way and drive us to the hypothesis of "autochthonous revival." These cases are so numerous that we are obliged to assume the existence of a collective psychic substratum. I have called this the collective unconscious'.<sup>2</sup>

---

<sup>1</sup> Samuels, A., Jung and the Post-Jungians, (London 1985): p24

<sup>2</sup> C. W. 9,I: 262

This view is very different to the Freudian notion of the unconscious which regards the unconscious as being composed of merely repressed personal material; within the Jungian model this forms only one aspect of the unconscious and was termed by Jung the 'Personal Unconscious'. Further the 'personal unconscious' is always viewed in the context of the wider more autonomous objective psyche.

At this stage in the definition of the archetypal two factors can be isolated. First the universality of archetypal images, and secondly their collective quality. To these conditions two further factors can be added, one: depth, and two: autonomy. The term depth indicates the belief that these images form the lowest or most basic levels of the objective psyche and are the patterns for the construction and regulation of the unconscious. The term 'autonomy' on the other hand indicates the existence of these patterns outside of specific cultures and personal psychologies.

Five years later in 1917 Jung's thought had developed and he now believed that the objective psyche expressed itself through a series of interrelated dominant images. These recurring dominant images he called 'nodal points', and they formed the archetypal cores around which other, subsidiary archetypes, gathered. As Samuels comments, the archetypal centres were regarded as:

'... Special nodal points around which imagery clustered... The important thing to note in the move from primordial image to dominant is that the innate structure... is regarded as more and more powerful, to the point where it becomes actor rather than acted upon'.<sup>1</sup>

It was not until 1919 that Jung introduced the term 'archetype'. At this

---

<sup>1</sup> Samuels: p24

time he was particularly aware that any theory of how images, or information is passed on through time, is in danger of succumbing to the Lamarkian fallacy. This states that, '... the evolutionary origin of adaptations lies in the adaptation of individuals during development and the hereditary TRANSMISSION OF THESE ACQUIRED ADAPTATIONS...' <sup>1</sup> (My caps). With regard to psychology, this fallacy would suggest that memories of specific ancient experiences, (the acquired characteristics), are inherited from generation to generation. This would fit very neatly with archetypal theory, but unfortunately it is wrong and the current view in psychoneurology is that mental imagery is not inherited. However, it is acceptable to say that a form or pattern, although not its contents, is inherited. (A concrete example of this distinction will be given shortly). As the analytical psychologist Samuels has noted,

'The archetype is seen as a purely formal skeletal concept, which is then fleshed out with imagery, ideas, motifs and so on. The archetypal form or pattern is inherited but the content is variable, subject to environmental and historical changes'.<sup>2</sup>

This distinction between form and content became important for Jung as did the transcultural and transhistorical aspects of the archetype, and this is demonstrated in the following comments.

'The concept of the archetype, which is an indispensable correlate of the idea of the collective unconscious, indicates the existence of definite forms in the psyche which seem to be present always and everywhere... This collective unconscious does not develop individually but is inherited. It consists of pre-existent forms, the archetypes, which can only become conscious secondarily and which give definite form to certain psychic contents'.<sup>3</sup>

---

<sup>1</sup> Smith, M., The Theory of Evolution, (London, 1958). This edition, (London, 1966): p13

<sup>2</sup> Samuels: p25

<sup>3</sup> C. W. 9, I: 89-90

'The archetypal representations (images and ideas) mediated to us by the unconscious should not be confused with the archetype as such. They are very varied structures which all point back to one essentially "irrepresentable" basic form. The latter is characterized by certain formal elements and by certain fundamental meanings, although these can be grasped only approximately'.<sup>1</sup>

A concrete example of this distinction between archetypal form, which is more accurately termed 'pattern', and its contents, or 'image' would be the figure of the hero. Here the hero represents the archetypal pattern and this pattern assumes a variety of images; the warrior-hero, the intellectual-hero, the detective-hero, etcetera. So while the form, hero, remains constant, the content, in this example the image of the detective, is influenced by cultural factors. Therefore, when looking at this as a cultural pattern the analyst should be able to trace a constant hero pattern or form, and developing hero image. Both of these factors, the constant pattern and changing image, indicate a culture's psychological condition. That is to say that the psychological condition of a culture calls forth both the relevant archetypal patterns and moulds the image in which these patterns find expression. As Jung has observed,

'Contents of an archetypal character are manifestations of processes in the collective unconscious. Hence they do not refer to anything that is or has been conscious, but to something essentially unconscious. In the last analysis, therefore, it is impossible to say what they refer to... The ultimate core of meaning may be circumscribed, but not described. Even so, the bare circumscription denotes an essential step forward in our knowledge of the pre-conscious structure of the psyche, which was already in existence when there was as yet no unity of personality (even today the primitive is not securely possessed of it) and no consciousness at all'.<sup>2</sup>

This means that the basic archetypal forms or patterns can be detected over periods of time, even if their subsidiary contents vary. (Though of

---

<sup>1</sup> C. W. 8: 417

<sup>2</sup> C. W. 9, I: 265

course neither image nor pattern may be fully understood). It is the role of the analyst to strip away the layers of cultural encoding to reveal the basic archetypal forms, and to then discern the relationship of these forms to the culture. If a psychological understanding of culture is to be achieved, then the analyst must examine both form and content, pattern and image: the totality of the archetypal core.

#### THE ARCHETYPAL CORE: ITS DYNAMIC AND FORMAL ASPECTS

So far within the archetypal core four key elements have been identified; universality, collectivity, depth and autonomy. It is suggested that if these elements are to be comprehended within the cultural context reference must be made to the archetypal core's dynamic and formal aspects. By 'dynamic' is meant the energy of the archetypal pattern which is its motivating force. It is this force which propels both the psyche and culture in a predetermined fashion: that is towards an integration of ego-consciousness with the unconscious. As Whitmont notes, 'The objective psyche, as an a priori datum, imposes upon our subjective selves the forms and limitations which determine the quality of our experiences'.<sup>1</sup>

Of more immediate concern to this chapter is the objective psyche's formal aspects which are the representational experiences, or images, of the archetypal patterns. Whitmont has identified three key points at which these representational experiences occur. These are times at which the pattern and its image are activated and can therefore be detected. (It should be noted that whilst Whitmont is writing about the personal clinical situation,

---

<sup>1</sup> Whitmont, E. C., The Symbolic Quest: basic concepts of analytical psychology, (Princeton, 1978): p79

his observations are equally valid for the larger cultural macrocosm).

- 1) '... in the analytical situation when complexes have been understood and dealt with but when a step beyond the understanding of their personal genesis is required'.  
(In other words as part of a normal maturation or life growth process).
- 2) 'Archetypal images may appear spontaneously when inner or outer events which are particularly stark, threatening or powerful must be faced...'
- 3) 'In cases of imminent or acute psychosis and in cases of demonic or religious "possession," the objective psyche takes over...' (At this point as the objective psyche is composed, in part, of the archetypal core, archetypal patterns and images will be seen in profusion).<sup>1</sup>

If a culture is undergoing any of the above changes then it would be expected to provide the cultural analyst with a particularly rich period of archetypal imagery. While it is possible to start with a known psychosis and from this make some deductions about the expected type of imagery, the conventional Jungian analytic procedure is the reverse. That is it starts with whatever images the objective psyche presents, these are then placed in relationship to the patient or culture and from this the analyst deduces the psychological conditions of the subject. As Whitmont comments, '..Our source of current mythological representation describes a situation in terms of psychic inner truth and reality'.<sup>2 III</sup>

However it is important to note that even towards the end of his life Jung was still anxious to state that total understanding of an archetype, and hence its full psychological comprehension, can never be achieved. An archetype in its fullest sense can never be fully understood, or comprehended.

---

<sup>1</sup> Whitmont: p73-74

<sup>2</sup> Whitmont: p77



'Not for a moment dare we succumb to the illusion that an archetype can be finally explained and disposed of. Even the best attempts at explanation are only more or less successful translations into another metaphorical language. (Indeed, language itself is only an image.) The most we can do is to dream the myth onwards and give it a modern dress. And whatever explanation or interpretation does to it, we do to our own souls as well, with corresponding results for our own well-being. The archetype - let us never forget this - is a psychic organ present in all of us'.<sup>1</sup>

By 1946 Jung was still making a very strong distinction between archetype and image, or form and content, and he also continued to stress the dynamic aspect of the archetype. Thus there was an emphasis on the way in which the form determines the development of the psyche.

'Now the archetypes do not represent anything external, non-psychic, although they do of course owe the concreteness of their imagery to impressions received from without. Rather, independently of, and sometimes in direct contrast to, the outward forms they may take, they represent the life and essence of a non-individual psyche. Although this psyche is innate in every individual it can neither be modified nor possessed by him personally. It is the same in the individual as it is in the crowd and ultimately in everybody. It is the precondition of each individual psyche, just as the sea is the carrier of the individual wave'.<sup>2</sup>

In fact Jung develops this thought even further and goes on to regard archetypes as the ultimate structuring potential for both the individual and humankind. This seems not only to validate the analysis of archetypal patterns and their images but adds a sense of urgency and import to that role.

'... our personal psychology is just a thin skin, a ripple upon the ocean of collective psychology. The powerful factor, the factor which changes our whole life, which changes the surface of our known world, which makes history, is collective psychology, and collective psychology moves according to laws entirely different from those of our consciousness. The archetypes are the great decisive forces, they bring about the real events, and not our personal reasoning and practical intellect... the archetypal images decide the fate of man'.<sup>3</sup>

---

<sup>1</sup> C. W. 9, I: 271

<sup>2</sup> C. W. 16: 354

<sup>3</sup> C. W. 18: 371

To summarise the current findings of this chapter:

- 1) There is an archetypal core, which is the collective term for all the archetypes, and this core is composed of dynamic and formal aspects.
- 2) The archetypal patterns liberated from this core indicate the psychological condition of the culture which frees them.
- 3) The general characteristics of archetypes are that they possess: depth, collectivity, autonomy and universality.
- 4) It is the archetypal patterns and not the contents (images) which possess the attributes listed in (3) above.
- 5) Archetypes also transcend historical and cultural boundaries.
- 6) The archetypal patterns and not contents determine the development of a patient/culture and cause them to take account of the objective psyche.

#### A CRITIQUE OF ARCHETYPAL THEORY

The concept of the archetype is central to analytical psychology. It is also going to assume an increasingly dominant role in this thesis, and because of this it seems wise to pause for a moment to take account of some of Jung's critics. What follows is a brief examination of four of his critics, and these particular critics have been chosen because they have stressed how unlikely the existence of the archetype is. The first of these four, Hobson, suggests that there are four criteria for defining an archetypal image. These criteria, he claims, have been derived from guidelines latent in Jung's writing, and he further claims that these four criteria are almost impossible to satisfy. As all these criteria must be applicable to a certain image before it can be called archetypal, it is his contention that archetypes remain at best highly improbable. The four criteria he has

isolated are:

- A) The material must be specific, occur regularly in different peoples and also occur as personal material.
- B) The image must appear in different cultures and at different times.
- C) There must be similar meaning whenever and wherever the image appears.
- D) There must be no possibility of the image being acquired through acculturalisation.<sup>1</sup>

To take the criticisms, or points, one at a time:

A) It is correct that archetypal material must be specific and must also occur regularly in different peoples. However it is not vital that it should also occur in the material of one person, although it would be expected that archetypal material would occur both culturally and individually. Or to use the technical terms both as phylogenous material and ontogenous material.<sup>IV</sup> However this is not a prerequisite for an archetype.

B) Here Hobson seems confused because it is not the image that must appear in different cultures and at different times, but the pattern. In his defence Hobson is quick to indicate that Jung is all too often unfortunately vague in using terms like form, motif, etcetera. While this is true it is normally possible to determine how Jung was intending the term to be used. For example with the term 'form', on the few occasions when confusion may arise, it is often possible to work out whether Jung is referring to the form of the image (detective) or the form of the archetypal pattern (hero). Although in fairness to Hobson, it should be admitted that Jung's semantic laxity can sometimes raise difficulties in interpreting specific passages.

---

<sup>1</sup>Extracted from Samuels: p33

C) Again Jung does not require that 'there must be a similar meaning', although it would be expected to find readings in which there was a degree of general agreement. Jung always remained open to the possibility that images may change their meanings, and it is the intent of the pattern which remains constant.

D) This point remains accurate and valid, and the qualifications to this point have already been discussed above.

Unfortunately for Hobson's arguments his points seem to rely upon a deliberately extreme interpretation of Jungian theory, and in taking an essentially static position in what is in essence a developing organic theory based on a developing life process, he seems to misrepresent some of Jung's central arguments.

The second of the four critics is Glover and he has three key points of attack against archetypal theory:

- A) Why should 'old' be regarded as wise and venerable? Also wisdom grows with the development of conceptual forms. And phylogenetically old was once ontogenetically young and, in fact, crude.
- B) Archetypal material simply consists of the left over parts of a child's pre-reality thinking, residues of primary process activity, e.g. pain, pleasure, gratification.
- C) Innate structures in the psyche lead simply to repetitions and cannot be cumulative.<sup>1</sup>

A) In answer to the first of these criticisms it should be pointed out that archetypes are not necessarily regarded by Jung as wise or venerable. They are regarded as providing the basic patterns for the structuring of human development. Thus the argument that 'phylogenetically old was once

---

<sup>1</sup> Extracted from Samuels: p34

ontogenetically young' is interesting but irrelevant, because the argument still remains that the basic patterns for the development of mankind would be present regardless of individual age, or the age of the species. The way in which these patterns found expression in the images of the developing species would of course vary, and it would be expected that these images would become more and more sophisticated, (i.e. more and more sophistic) as mankind developed.

B) The second of Glover's points is more difficult to deal with. To argue from Glover's position requires that the internal experiences, such as pleasure and pain assume a structured form. However it should be noted that these internal functions, pleasure and pain, must possess an external component. In other words internal and external forms interrelate. Thus the autonomy of the archetypal structures which, as mentioned are the property of the psyche, are lost. These pieces of 'pre-reality thinking' do not have the structuring autonomous power of archetypes, therefore the residues of 'primary process of activity' cannot be archetypes.

C) Glover's third point is easier to criticise. He has unfortunately failed to realise that while the archetype is a fixed pattern it is also, as Samuels notes,

'a structuring potential which evolves towards its goal over time. A simple analogy would be the way in which genetically inherited phenomena emerge during maturation - such as bodily changes which occur at the appropriate point in time. It would not be argued that the gene is unimportant because of this'.<sup>1</sup>

Again it would appear that while some of Glover's criticisms are interesting none of them seem particularly damning to the archetypal hypothesis.

The third of the critics, M. Fordham, is in fact an analytical psychologist.

---

<sup>1</sup> Samuels: p35

He is concerned about the emphasis which is placed on historical and mythological material.

'A patient who produces archetypal material with striking alchemical parallels is not practising in the alchemical laboratory, nor is he living in the religious and social setting to which alchemy was relevant. Therefore, it can become unrealistic... if this is thought of as alchemical ... the patient becomes more divorced than before from his setting in contemporary life'.<sup>1</sup>

Once again many of Fordham's criticisms become invalid when it is realised that he is talking about image and not pattern. In this case it is the image of alchemy he writes about and not the more basic pattern, which is the individuation process. Providing that the analyst is using these images, and indeed associated images, to gain further information about the nature and operation of the archetypal pattern, then the mythological approach is valid. If however the images are seen as separate or divorced from the pattern, then the method is open to Fordham's criticisms. Given Fordham's criticisms it is curious to note that he finds 'pre-cursors of his own theories of infancy in cosmic egg creation myths'!<sup>V</sup>

The last of these four critics, Dry, has similar concerns to those of Fordham. She too is concerned about the emphasis that is given to myth, legend and fairytale, and remains unconvinced by apparent connections between children's fantasies, their imagery and any archetypal patterns. She even goes so far as to question if there is any point in invoking the collective unconscious in the shape of the hero myth.

'She prefers to suggest that the myth is a secondary elaboration of the primary infantile experience. She is therefore not at all in agreement with the idea of archetype as a blueprint for experience'.<sup>2</sup>

---

<sup>1</sup> Fordham, cited Samuels: p35

<sup>2</sup> Samuels: p36

While Dry does not recognise the structuring potential of the archetypal pattern, neither does she provide a coherent criticism nor an alternative model. The flaws in regarding archetypes as remnants of infantile experiences have already been demonstrated, c.f. Glover, point (B).

To summarise: out of the four critics who have been evaluated, none of them brings a sufficiently strong criticism to invalidate the archetypal hypothesis. In fact some of their criticisms have helped to strengthen the hypothesis and have drawn attention to the importance of including mythological material in archetypal analysis. They have also somewhat unwittingly high-lighted the vital distinction between image and pattern. It should be restated that any mythological material which is brought to bear on an archetypal analysis is valid only in as much as it relates to the basic archetypal pattern and not to other images belonging to a different pattern. It is therefore valid, indeed essential, to use mythological material from a variety of cultures and periods in history, in archetypal analysis, with the provision that these images relate to the same pattern. Therefore references should constantly be made to the archetypal pattern under analysis and to how this pattern relates to the patient or culture.

#### THE CLASSIFICATION OF ARCHETYPES

Up to this point in the chapter, archetypes have been treated as belonging to one common core, and this core was seen to be the possessor of both dynamic and formal energies. In fact this core is composed of various discrete or individual archetypes which, whilst interrelated, possess in their individuality the attributes of the larger core, and Jung also noticed a tendency for these individual archetypes to become personified. Given the variety and complexity of archetypal patterns and images it seems important

to have some method for their organisation. Without this there is the danger of confusion, and of becoming lost in the uncharted waters of the unconscious. There exists a variety of ways or systems which can be used to organise archetypes, and this chapter will now examine three such systems and select the most appropriate system for future use in the thesis.

Perhaps the most conventional, or traditional, way to organise the archetypes is to start from the outside, that is to start from the world and work inwards to the unconscious. The first archetype in this system is therefore the persona. The term 'persona' originally referred to the mask worn by Roman actors, and Jung used this term to mean the mask that we put over our inner selves to encounter the outer world.

'the persona... is the individual's system of adaptation to, or the manner he assumes in dealing with, the world. Every calling or profession, for example, has its own characteristic persona... A certain kind of behaviour is forced on them by the world, and professional people endeavour to come up to these expectations. Only, the danger is that they become identical with their personas - the professor with his textbook, the tenor with his voice. Then the damage is done; henceforth he lives exclusively against the background of his own biography... One could say, with a little exaggeration, that the persona is that which in reality one is not, but which oneself as well as others think one is'.<sup>1</sup>

Continuing on the inward journey the next archetype is the shadow, otherwise termed the inferior function. The previous chapter has already explored a lot of shadow related material, so this theoretical approach indicates the foundations of what has gone before and anticipates future developments in its application to the analysis of films. The term 'shadow' represents all that man dislikes about his or her own psyche, hence it is the 'inferior' part of the personality. The danger is that because the shadow is so intensely disliked it may form a separate splinter personality, and this is

---

<sup>1</sup> C. W. 9, I: 221



what occurred in Tightrope,<sup>VI</sup> (Dir. R. Tuggle, Warner, 1984). In the following two extracts Jung explains the shadow's negative qualities.

'I should only like to point out that the inferior function is practically identical with the dark side of the human personality. The darkness which clings to every personality is the door into the unconscious and the gateway of dreams, from which those two twilight figures, the shadow and the anima, step into our nightly visions or, remaining invisible, take possession of our ego-consciousness'.<sup>1</sup>

'The shadow personifies everything that the subject refuses to acknowledge about himself and yet is always thrusting itself upon him directly or indirectly - for instance, inferior traits of character and other incompatible tendencies'.<sup>2</sup>

Finally, and most removed from the outerworld, are the contrasexual archetypes the animus and anima. According to Jung the animus represents what is masculine in woman and the anima the feminine in man.

'Anima and animus may appear as human figures, but they may be more accurately seen as representative of archetypal patterns. For example, anima speaks of imagination, fantasy and play, while animus refers to focused consciousness, authority and respect for facts. Nowadays, it is widely regarded as fallacious to link such psychological traits to sex. Anima and animus can be understood as representing alternative modes of perception, behaviour and evaluation'.<sup>3</sup>

Overleaf is a diagram of this system and this will add clarity to this method of classification.

Another widely used method for ordering archetypes,<sup>VII</sup> is to divide the archetypal core into four main categories.

---

<sup>1</sup> C. W. 9, I: 222

<sup>2</sup> C. W. 9, I: 513

<sup>3</sup> Samuels, A., Shorter, B., Plant, F., The Father. Contemporary Jungian Perspectives. Ed. Samuels, (London, 1985): p250

Conventional Method for Classification of Archetypes

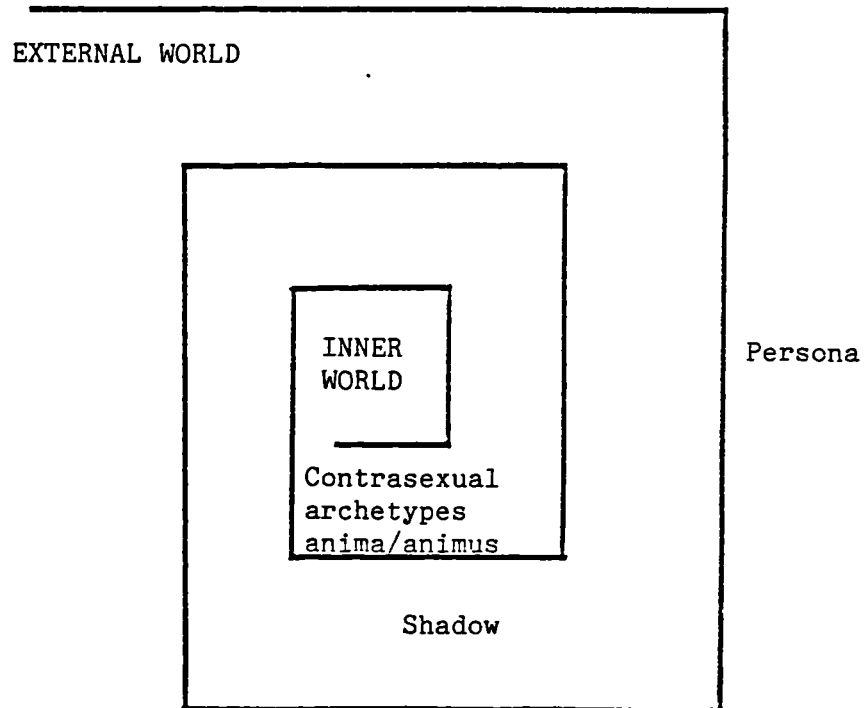

'First there are the "shallow" archetypes such as persona and shadow, then "archetypes of the soul" (animus and anima), then "archetypes of the spirit" (wise old man and woman), and, finally, the Self'.<sup>1</sup>

The main problem with this method is its rigidity and its use of ill defined terms like spirit and soul. Also the term spirit could perhaps better be applied to the contrasexual archetypes rather than the wise old man or woman. Again a diagram follows overleaf, representing the above cited system of classification.

---

<sup>1</sup> Samuels, A., Jung and the Post Jungians, (London, 1985): p32

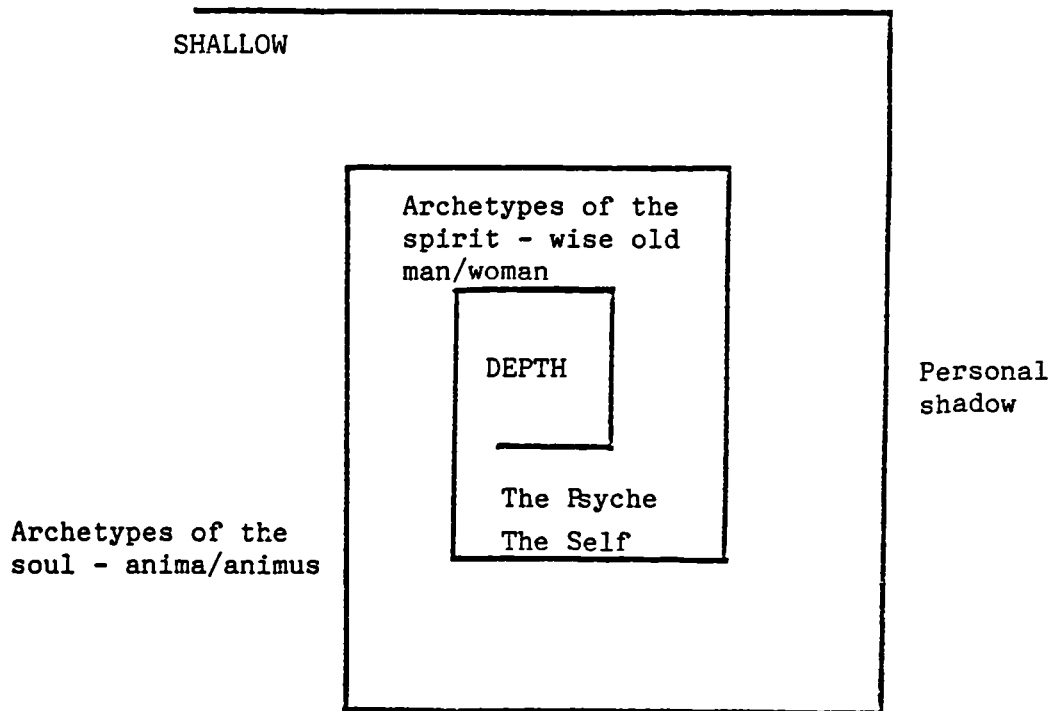
Alternative Method for the Classification of Archetypes

There exists the danger with these concrete approaches that the archetypes are dealt with in a strict and predictable order. For example: persona, shadow, anima/animus, Self. This seems an overly simplistic interpretation of Jung's thought and fails to take into account his insistence that every situation be treated as fresh and original.

A less formal system for classifying archetypes, which also overcomes these limitations, involves first finding an archetypal theme, and then seeing how various archetypal patterns and their associated imagery gather round it. An example of such an archetypal theme might be the creation myth. This myth possesses a different tone when viewed in differing cultures. It would also be expected that the myth would attract different collections of archetypes and these archetypes would vary according to the specific psychological needs of the culture. The psychotherapist Stein developed this

system of archetypal themes in his paper 'Introducing not Self'.<sup>VIII</sup> Here he spoke of single archetypes and also aggregates of archetypes, anima/animus, shadow, etcetera, which he regards as the composites of single archetypes.

'I therefore make a distinction between discrete archetypes as such, and more or less abstract aggregates like animus, anima, shadow... The refutation of the linear arrangement in preference to a framework of planes permits... archetypal images to be placed on the lower, earlier, more archaic, more consolidated, more resistant level of the self... it is postulated that individual constituents arrange themselves in pairs of opposites... archetypes as the constituents of the self are interrelated and this interrelatedness is teleological, i.e., serves the well-being of the individual as a whole .

This method for classifying archetypes is illustrated in the following diagram.

A Model of Stein's Method of Archetypal Classification - With Example

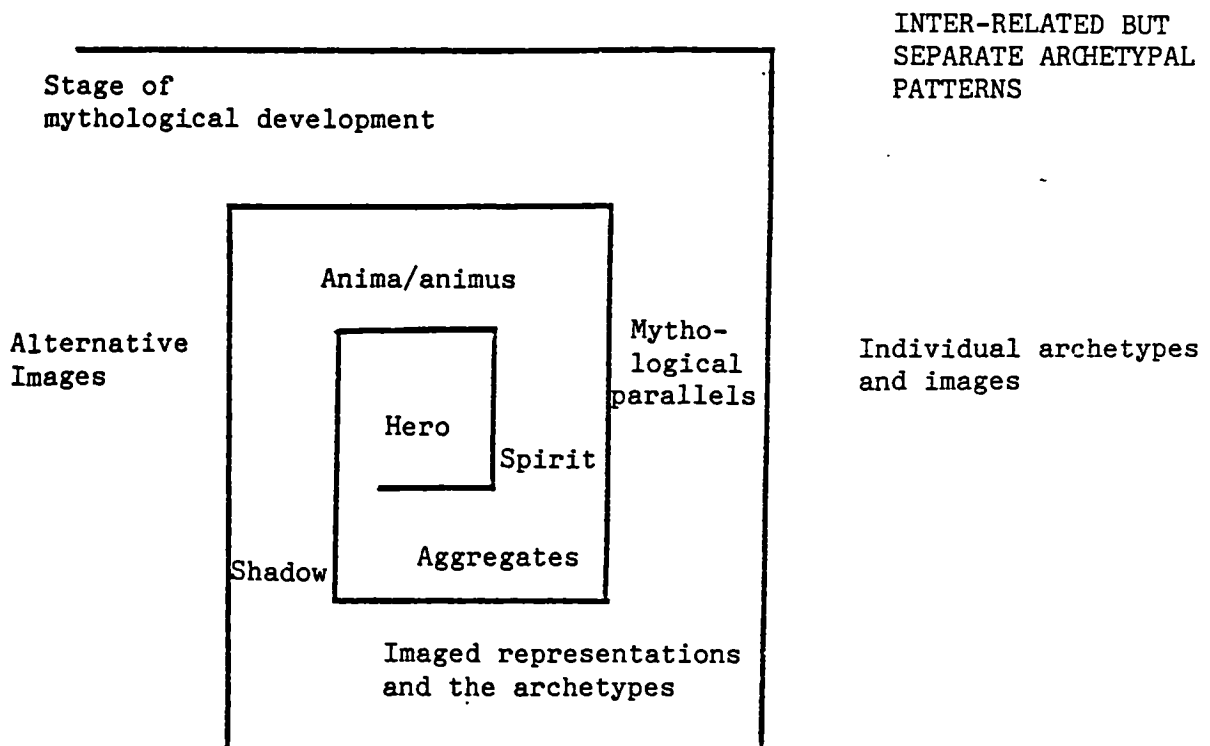

<sup>1</sup> Stein, L., 'Introducing not Self', Journal of Analytical Psychology, Vol. 12: 2 (1967): p102-103

What is important is the fluid or organic nature of this model, and this allows a variety of archetypal images to cluster around the same pattern. For the analyst this is a useful way of approaching archetypes as it allows a number of different archetypal images, possibly from different cultures and historical periods, to constellate around one central archetypal pattern. This should lead to a fuller understanding of the formal and dynamic aspects of the pattern, and it will allow the analyst to gain a deeper knowledge of the archetypal forces, and hence a deeper knowledge of the patient or culture.

First it will be helpful to recap on the main findings of this chapter, as this leads to an increased awareness of how the model incorporates these themes, and how the somewhat complicated process of analytical psychology can be used in film analysis.

### Summary

- 1) The objective psyche consists, in part, of an archetypal core which contains archetypal patterns.
- 2) These archetypal patterns contain the structuring potential for the psyche, which is the individual process.
- 3) These patterns which are transpersonal, transhistorical, and transcultural are expressed in a variety of images which differ from age to age and culture to culture.
- 4) In trying to organise archetypal forms it is most useful to select an archetypal theme, and to then see how various images cluster around it.
- 5) These images can then be analysed to reveal their composition which is of both aggregate and discrete archetypal patterns, symbols and mythologems.

- 6) The opposites of the archetypes, symbols and themes should be explored.
- 7) The archetypes, symbols and mythologems are interrelated and teleological, i.e.: they serve the well-being of the psyche. Therefore these factors are interrelated because they are all part of the individuation process.

#### A MODEL FOR THE APPLICATION OF ANALYTICAL PSYCHOLOGY IN THE ARCHETYPAL ANALYSIS OF IMAGES

The final part of this chapter is concerned with the creation and evaluation of a model which helps the critic to conduct a broadly archetypal analysis. However before the model is presented, its aims and a brief example of its operation will be discussed.

The task of creating a model from analytical psychology which includes all the above points, is complicated by Jung's general remarks about the nature of the unconscious. For example,

'The unconscious is the matrix of all metaphysical statements, of all mythology, of all philosophy (so far as this is not merely critical), and of all expressions of life that are based on psychological premises'.<sup>1</sup>

Given the encompassing nature of this statement it is difficult to see how any model could be of use. The psychiatrist M. L. von Franz would agree with this and has made the following observation,

'Many people have criticised the Jungian approach for not presenting psychic material systematically. But these critics forget that the material itself is a living experience charged with emotion, by nature irrational and everchanging, which does not lend itself to systematization except in the most superficial fashion'.<sup>2</sup>

---

<sup>1</sup> C. W. 11: 899

<sup>2</sup> von Franz, M. L., 'The Process of Individuation', in: Man and His Symbols, Ed. Jung, C. G. and von Franz, M. L., (London, 1964). This edition, (London, 1978): p167

It is the intention of this section of the chapter to demonstrate that Franz is in fact mistaken and it is possible to produce a more concrete, yet still organic, model which allows for the changing nature of the material itself. It is hoped that this can be achieved in a more than 'superficial fashion'.

The model is supposed to provide a guide for the analysis of spontaneous image creations, and to do this according to the theory and practice of analytical psychology. It is also supposed to assimilate the previous points concerning archetypal theory, and to place them into a slightly more practical and concrete form. It is hoped that this will be achieved despite the dangers of exclusion and oversimplification. (How this model assimilates the theoretical findings of the chapter will be discussed shortly).

The model in its current form, illustrated below, is not supposed to include such areas as: psychology of the author, (although with the relevant type of theory it could be extended to include this aspect), the narrative of the film, (although in analysing narrative elements such as myth themes and symbols the narrative would be examined *passim*). Neither is the model supposed to examine any specifically filmic techniques such as camera-work or editing. However potentially a consideration of these factors could be derived from an analysis of the film's 'language' which is taken to also include the *mise-en-scene*, the characters, and so on.<sup>IX</sup> How these elements relate to the wider myth/psychological themes and how they are connected to specific filmic devices such as editing will become clear during the application of the theory in film analysis. Indeed the term 'mythology' could be used to include the above elements of cinematic construction, but, if such an extension was made, it would be necessary to demonstrate how this mythology of form relates to the central mythologem. However, due in part to the

limitations of space, it is not the intention of this thesis to extend the model in any of the above ways, but to keep it at a more simple and accessible level. Now that its boundaries have been determined it seems appropriate to discover what is contained within them.

Analytical Model

	Archetypal Pattern	Mythologem
Archetype's Image		
Mythology		
Individua- tion Process		

The model consists of a grid of six active squares, the outer squares being used only to label the axes. It is designed to show the changing, or organic, relationships which exist between the different elements of archetypal analytical analysis, and it is hoped that this will reflect Stein's observation that all the parts of the analytic system are interrelated. This should result in a flexible yet formalised approach to the analysis.



The archetypal pattern column will be examined first, and as can be determined from the model it will be seen in relationship with the rows labelled, archetype's image, mythology, and individuation.<sup>X</sup> However it seems important to approach this exercise with a cautionary note. When imposing a formal scheme on something as organic as an archetype it is important to stress once more that archetypes are ultimately unknowable. So no matter how integrated the analysis is, archetypes will essentially remain mysterious. As Jung comments,

'No archetype can be reduced to a simple formula. It is a vessel which we can never empty, and never fill. It has a potential existence only, and when it takes shape in matter it is no longer what it was. It persists throughout the ages and requires interpreting ever anew. The archetypes are the imperishable elements of the unconscious, but they change their shape continually'.<sup>1</sup>

It is not the intention of this model to reduce the archetype to a 'single formula', but to regard it as part of an integrated system, and for this chapter's method the system is composed of five elements; archetype's image, archetypal pattern, mythology, mythologem and the individuation process. First a consideration of the archetype's image as it relates to the concept of the archetypal pattern.

Initially it is important to discover exactly what pattern or patterns are being expressed. For example is it the hero, the father, the trickster or perhaps the wise old man, and what shape (images) do these patterns take in the film? This then raises the question of what these patterns are in opposition to, and both Jung and Stein stress the importance of opposites which are then reconciled as part of the individuation process. Thus the central or key questions for this square are: What archetypal patterns are revealed, how are they expressed and what are they in opposition to?

---

<sup>1</sup> C. W. 9, I: 301

To progress to the relationship between archetype's image and mythology, in this section the analyst would look at two factors. First what is the mythology of the film - how is its general imagery characterised and how does this relate to the archetypal patterns and images? Secondly and more importantly he would look for the historical parallels to the images, and these parallels are valid only if they relate to the archetypal pattern.

As Jung notes,

'The history of religion in its widest sense (including therefore mythology, folklore, and primitive psychology) is a treasure-house of archetypal forms from which the doctor can draw helpful parallels and enlightening comparisons for the purpose of calming and clarifying a consciousness that is all at sea. It is absolutely necessary to supply these fantastic images that rise up so strange and threatening before the mind's eye with some kind of context so as to make them more intelligible. Experience has shown that the best way to do this is by means of comparative mythological material'.<sup>1</sup>

If in the above suggestion Jung's advice is followed, then it is the role of the analyst to discover as many mythological parallels to the film's central archetypal pattern as possible. The myths may appear to differ widely but, providing they inform about the movement and direction of the central archetypal pattern then they are valid. Perhaps the central questions raised in this square are: what are the mythological parallels to the uncovered pattern, and how do these parallels inform as to the impetus of the central archetypal pattern?

The last of the squares in this row should prompt the analyst to consider what stage the individuation process in the film has reached, he or she should also note how this is reflected in the archetypal pattern and observe what oppositions are being unified. As already stated opposition is vital to the Jungian argument, and because of this it is always important to search

---

<sup>1</sup> C. W. 12: 38

for opposition but to then see how the individuation process overcomes these apparent differences. As Samuels has commented,

'For Jung, bipolarity is the essence; it is a necessary condition for psychic energy... Jung suggests that it is fruitless to search for the primary member of a pair of opposites - they are truly linked and cannot be separated; they involve each other... It is certainly true that Jung was influenced by Hegel, that he did conceive of psychological process in terms of discrimination and then synthesis of opposites. 'The experience of synthesising the opposites involves a process of balancing or self-regulation. Jung refers to this as compensation... Compensation may initially appear in the negative guise of symptoms. It is not to be thought of as implying that balance is regularly or easily attainable'.<sup>1</sup>

Once this column is completed, the analyst will have examined the following aspects of the film: the interrelationship of the archetypal pattern and its associated imagery, the historical parallels to this pattern and their imagery, seen how both the images and patterns relate to the individuation process, and noted how this process is visualised in the material under consideration.

The second column is concerned with the relationship between the mythologem and the archetype's image and the mythology and the individuation process.

The first of these relationships from the model is between the mythologem and the archetype's image. At this point the analyst should be attempting to discern the main theme of the myth and to see how this is connected to the images of the archetypes in the film. However it is important to stress that it would not be expected to find an uncomplicated statement of the mythologem clearly exposed and stated in the film, because, as Whitmont states,

---

<sup>1</sup> Samuels, A., Jung and the Post Jungians, (London, 1985): p92-93

'To act out a mythologem literally would be stark madness. It is always a question of how much may be realized in terms of what is humanly, practically and ethically possible. Hence the archetypes too may have to be resisted and bargained with - in order to assimilate them in forms of what is realistically possible, but never are they to be lightly disregarded'.<sup>1</sup>

As a result of this the mythologem may be well concealed amongst the images, and it may become necessary to 'strip away' much of the film's language, symbolism and mythology to reveal the naked central myth theme. This is not an easy skill, and can best be acquired through a diverse knowledge of mythological themes, as this way the analyst becomes familiar with the recurring motifs.<sup>XI</sup> Thus the central questions for this square are simply: What is the main myth theme and what are its auxiliary themes?

The result of this interaction between the mythologem and the archetype's images, must be the production of mythological images. The archaic themes, which are the property of the mythologem should constantly be expressed and re-expressed in fresh and appropriate imagery. As Jung comments,

'We have to imagine a millennial process of symbol-formation which presses towards consciousness, beginning in the darkness of prehistory with primordial or archetypal images, and gradually developing and differentiating these images into conscious creations'.<sup>2</sup>

Continuing this concept of 'symbol formation' in the penultimate square the analyst is prompted to examine the interaction between the mythologem and the mythology. The reason behind this is that when the myth theme and the mythology interact, the ancient symbols, which belong to the depths of the objective psyche, may be released. To once again quote Whitmont,

---

<sup>1</sup> Whitmont: p128

<sup>2</sup> C. W. 11: 469

'Thus we are forced to resort to a cognitive mode which our rational development has tended to by-pass: the symbolic mode, which in the historical development of the human mind is found to be the active element in the formation of recurrent mythological images... This mythologem-forming symbolic approach is thus an approach to reality, especially to psychic or transpersonal or cosmic reality, which concedes our inability to know this reality in intellectual terms'.<sup>1</sup>

Thus the questions for this square are: what symbols are liberated in this myth, how do they relate to the archetypal pattern and the individuation process, and what oppositions are contained with these symbols?

Finally the mythologem needs to be viewed as an integral part of the individuation process. As von Franz has observed,

'... beneath the surface a person suffering from a deadly boredom that makes everything seem meaningless and empty. Many myths and fairy tales symbolically describe this initial stage in the process of individuation'.<sup>2</sup>

However the mythologem may also describe a more advanced stage of the individuation process. Thus it becomes necessary to discover the correlations between the individuation process and the way in which it is reflected in the mythologem, mythology, archetypal pattern and archetype's image.

Once this is achieved it should render a detailed understanding of the stage that individuation has reached and how this is visually depicted. So the question for this square is quite simply: how do the myth themes relate to the individuation process?

Once this column is completed the analyst will have examined the myth theme and seen this in tandem with the mythology of the film, and observed the resulting symbols. He or she will then have seen how this theme, the

---

<sup>1</sup> Whitmont: p34

<sup>2</sup> von Franz: p170

symbols and the mythology all interrelate and find expression in the imagery of the individuation process.

In conclusion this has been a very short introduction to the model, and it was only intended to give a general overview, or context, for the model. As a development of this, the next chapter is a brief example of how the model actually works when it is applied in practical film analysis, and after the film analysis there are two further theoretical chapters. The first of these chapters is on the symbol, and the second examines the individuation process. Once these are completed there will be a detailed practical application of the model, and its associated theory, to one film. This results in an extensive archetypal Jungian analysis of the film's imagery and intent. XII

Before advancing to the initial film analysis it will prove helpful to recap on the model, and to restate the central questions that each square raises.

The Analytical Model and its Central Guiding Questions

	Archetypal Pattern	Mythologem
Archetype's Image	What archetypal patterns are revealed, how are they expressed, and what are their opposite patterns?	What is the main myth and what are its auxiliary myth themes?
Mythology	What are the mythological parallels to the uncovered pattern, how do these parallels inform as to the impetus of the central archetypal pattern?	What symbols are liberated in this myth, how do they relate to both the archetypal pattern and individuation process? What oppositions do they contain?
Individuation Process	What oppositions are being unified in the individuation process?	How do the myth themes relate to the individuation process?

CHAPTER FOUR NOTES

- I. c.f. C. W. 8: 154
- II. c.f. C. W. 14: 129  
9I: 123f  
12: 149
- III. It is this conventional procedure which will be adopted by this thesis.
- IV. These are terms which psychology has adopted from biology where individual development is termed ontogeny and the evolution of the species and lineages is phylogeny.
- V. c.f. Fordham, (1957): p118-119. Cited, Samuels: p35
- VI. c.f. Previous chapter, Tightrope: The Detective and His Shadow: p84
- VII. c.f. Samuels: p32
- VIII. c.f. Stein, L., 'Introducing not Self', Journal of Analytical Psychology, Vol. 12: 2 (1967).
- IX. Here there are some similarities to the idea in Gestalt psychotherapy of working in the 'Here and Now'. This technique involves using only material that is available to the patient 'now', consequently use is made of dream analysis, word association etcetera. It is from this material that latent, deeper, unconscious associations are formulated. In the same way this model starts with the surface of the film and from this reveals deeper unconscious structures.
- X. It is not vital to proceed in this order; the analyst should be free to use the squares in the order which seems most appropriate for the material. However it is important to use all six squares.
- XI. This idea has a parallel in genre theory, in which a single film is viewed in the context of a variety of similar films and from this the 'conventions' of the genre arise. c.f. Grant, B. K., editor, Film Genre: Theory and Criticism, (Metuchen, 1977): p31
- XII. c.f. Part Three, Trancers: p226



Chapter Five

Blade Runner

INTRODUCTION

This chapter is an illustration of the model as it has been established in the previous chapter. It will demonstrate how the model can be used in film analysis, and consequently it will show the relevance of analytical psychology in this type of psychological film analysis. The film that has been chosen is Blade Runner (Dir. Ridley Scott, Columbia, 1982). This science fiction detective film is well suited as an example for the model, because it is rich in symbolic, mythic and archetypal themes. However before commencing the analysis of the film proper, there is a summary of the film's narrative.

Blade Runner is set in Los Angeles, 2019 and its narrative is structured and centred round Chinatown. The hero-detective Decker, is brought out of his retirement from the police 'Blade Runner Section', to capture and destroy, or 'retire', some escaped replicants. Replicants are biogenetic robots, supposedly perfect humans which have been created for specific tasks. For example there are warrior replicants and whore replicants, but whatever their role they all lack the capacity to feel. They are unable to have emotional experiences, and in this respect they are very much less than human. The replicants have escaped from the 'off world colonies' because they discovered that their life expectancy is only four years, and they plan to persuade their 'maker' Tyrell, to extend their longevity. Decker hunts down and retires all but one replicant, Rachel. Rachel has mysteriously started to develop and experience emotions, and Decker too finds his feelings getting out of control. Eventually they fall in love, and escape together to live in the open countryside of 'the north'.

ARCHETYPAL PATTERN AND ARCHETYPE'S IMAGE

In Blade Runner the central archetypal pattern seems to be the hero archetype, and this is expressed in the questing image of Decker as the hero-detective. On one level Decker is on a quest to retire the replicants, who after all are only imperfect copies of humans. On another more symbolic level he seems to be searching for different aspects of his psyche, and perhaps these different elements symbolise his own imperfections. In the Jungian model for the development of the psyche which was established in the previous chapters, there are four main elements. These are: sensation, thinking, feeling and intuition, and an important part of individuation is to recognise these different elements so that they can be assimilated into ego-consciousness. In the narrative of Blade Runner these elements seem to be personified by the replicants and it is Decker's task to first identify, and then retire them. As this task is associated with consciousness, that is the ectopsychic system, and because Decker is a hero, he is in opposition to the unconscious, indeed this opposition is inextricably bound up with the development of the psyche. One aspect of this unconscious opposition is personified in Rachel - Decker's anima. Perhaps Blade Runner can be regarded as a story of the hero Decker's symbolic search to unite these opposites and embrace his anima. As Jung has commented,

'The persona, the ideal picture of a man as he should be, is inwardly compensated by feminine weakness, and as the individual outwardly plays the strong man, so he becomes inwardly a woman, i.e., the anima, for it is the anima that reacts to the persona'.<sup>1</sup>

However before individuation can be achieved, and Decker can accept his anima, it is important for him to recognise that the psyche exists in a state of opposition. For Decker this realisation starts when he first

---

<sup>1</sup> C. W. 7: 309

meets Rachel, whom her maker Tyrell describes as, 'More than human'. It seems as though she is a projection of the positive aspects of Decker's anima, and that he has begun to realise that there is more in the psyche than just consciousness.

Decker next discovers that Rachel is a replicant. Yet at the same time she is a projection of his anima, and as a result of this he is bonded with, or at least attracted to her. He is also aware that he is beginning to change and this is obvious in his remark, 'Replicants weren't supposed to have feelings, neither were Blade Runners. What the hell was happening to me?' However before he can really accept and integrate the feeling dimension of his psyche, he must first move past the sensation side of his character. This sensation side is personified by the replicant Zhora, and Decker proceeds to 'retire' her. He now no longer needs to dwell on sensation, but can move deeper into the ectopsychic system where he fully enters the feeling stage and comments, 'There it was again. Feeling in myself for her, for Rachel'.

Before it is possible for Decker to integrate his anima, he must move from the feeling phase through the thinking stage, and he achieves this via the process of intellectual detective work. Now he is in a position to realise that the anima possesses negative as well as positive qualities. This is a stage of real insight for the psyche, because these negative qualities need to be accepted before the anima can be integrated into ego-consciousness. Decker psychologically achieves all this when he 'retires' the replicant Pris. She is a violent negative anima expression who unsuccessfully attempts to kill Decker by crushing his head between her legs. Perhaps it would be more accurate to say that she attempts to destroy the psyche that Decker symbolises.

Finally Decker must reject the totality of his stereo-typical hero persona, and this involves the destruction of his 'old warrior self'. He is then able to progress to the final intuitive phase which involves the integration of the anima, and results in wholeness of the psyche. The warrior self is personified by the replicant Roy, and Decker has to quite literally battle with him before Roy is finally destroyed. Decker is then able to escape with his anima/Rachel in the potential to live in wholeness and peace.

It will be seen as the analysis progresses that this initial reading of the archetypal pattern/image interaction is corroborated and extended by the myth themes, mythology and symbols. For clarity the development of the hero, Decker is summarised below.

#### Development of Hero Decker

- Hero - meets anima - Rachel
- Hero - Retires sensation self in Zhora
- Hero - Comes to terms with intellectual phase in development
- Hero - Retires anima's negative aspects in Pris
- Hero - Overcomes the old warrior self and moves through to intuitive phase
- Hero - Integrates his anima, Rachel

While discussing the archetypes in Blade Runner it is important to notice the appearance of what may be the wise old man archetype. This archetype guides the hero offering him advice and here he seems to be personified in the figure of Gaf. The character of Gaf is somewhat ambiguous, his age is uncertain, but he is older than the hero and probably of oriental extraction. He does not offer direct spoken advice to Decker and throughout the film he always remains one step ahead of Decker and, with apparent power of foresight seems to know at any time where the hero can be found. On the archetype of the wise old man, Jung comments,

'But figuratively speaking, he is the "informing spirit" who initiates the dreamer into the meaning of life and explains its secrets according to the teachings of old. He is a transmitter of the traditional wisdom. But nowadays the fatherly pedagogue fulfills this function only in the dreams of his son, where he appears as the archetypal father figure, the "wise old man".'<sup>1</sup>

If Gaf does not communicate through speech he does communicate via his symbolic paper origami creations.<sup>1</sup> His silence shrouds him in an air of mystery and calls to mind the saying, 'Those who know do not speak; those who speak do not know'.<sup>2</sup> This type of ambiguity serves to introduce one of the film's central themes - illusion. While Gaf does not speak, he still has great insight, it is as though his wisdom may be heard in his silence. It is also worth noting that his almost totally symbolic communications give him a proximity to the objective psyche which, it will be remembered, communicates through symbols.

#### ARCHETYPE'S IMAGE AND MYTHOLOGEM

The basic theme to the narrative seems to be the quest, but it is the quest for new life from old, for a rebirth of the psyche. The image of the quest is one metaphor of the individuation process and this indicates a link between the mythologem and archetypal pattern. Decker is engaged on the retirement of the old psyche and subsequent resurrection of the new, potentially individuated, Self. Therefore the myth theme can be extended to include a progression from life, to a death of the old life, to a new life. The narrative articulates this theme at its closure when Decker remarks of the replicant Roy, 'His questions were the same as ours. Where have we come from? Where are we going? How long have we got?' And in the world of symbols these themes of life and death are connected. As Jung notes,

---

<sup>1</sup> C. W. 12: 159

<sup>2</sup> Tao Te Ching, in From Primitives to Zen, Ed. Eliade, M., (London, 1977). This edition, (London, 1983): p600

'For in the secret hour of life's midday the parabola is reversed, death is born. The second half of life does not signify ascent, unfolding, increase, exuberance, but death, since the end is its goal. The negation of life's fulfilment is synonymous with the refusal to accept its ending. Both mean not wanting to live, and not wanting to live is identical with not wanting to die. Waxing and waning make one curve'.<sup>1</sup>

As already mentioned there is a secondary myth theme, illusion, and it is hoped to demonstrate that this is connected to the themes of life and death. From the beginning of the film Ridley Scott concentrates on pictures. There is the giant Coca-Cola advert with an oriental woman drinking coke<sup>II</sup> which recurs throughout the film, there is also the photograph which forms the vital clue in tracking down a replicant, and the old pictures which sit on Decker's piano. In a sense none of these images are real. They are representations of reality which have an ambiguous illusory quality and are almost pictures of the mind - not unlike the film itself. Continuing this theme, in order to help the replicants feel human they are given memories, and so theirs becomes a life of illusion, they have no real memories and no feelings, they are empty. The replicant Pris is like a toy doll,<sup>III</sup> she even moves like one in an animated clockwork fashion. Zhora performs with her snake in a sleazy Chinatown bar, where she performs as an erotic dancer selling the illusion of sex, and while Roy has seen many fantastic sights he is unable to possess that wonder, because he has no feelings, he is hollow or soulless. While not a replicant, Sebastian too is an illusion, he appears to be in his fifties, in fact he is twenty five and suffers from a disease called the 'Medusila Syndrome'.<sup>IV</sup>

This concern with paradox and illusion, or ambiguity, providing true understanding and insight is central to oriental philosophy. (Perhaps this goes some way to explaining why the film is set in Chinatown, and this also

---

<sup>1</sup> C. W. 8: 800

provides another link to the wise old man, Gaf). As the Tao comments,

'Everything is its own self; everything is something else's other... where there is life, there is death; and where there is death, there is life... whether in construction or in destruction, all things are in the end brought into unity...' <sup>1</sup>

This is like the previous passage of Jung where he noted that, 'not wanting to live is identical with not wanting to die', <sup>2</sup> and indicates how the themes of life and death and illusion are connected. It further extends both the themes by joining them in the concept of unity.

Thus the central mythologem and the archetype's images are united in the life, death, life, or rebirth, theme and the illusion theme, both of which stress the ambiguous and transitory nature of life. Again both of these themes find an expression in the subsidiary image of the quest, which is the search for the replicants and the search through illusion for reality - even if this reality is ultimately an illusion. The quest is also an allegory for the individuation process which is of course clearly connected to the rebirth theme, and for Decker individuation is intimately bound up with his search which takes him into the depths of the unconscious. It seems that for him part of individuation is a coming to terms with the ambiguity of his life and therefore with the ambiguity of his reality.

#### MYTHOLOGY, THE ARCHETYPAL PATTERN AND IMAGES

The question raised in this section is: what mythological parallels can be found for the rebirth and illusion themes, how do these inform us as to the archetypal pattern and its images? Here it is interesting to note that

---

<sup>1</sup> Eliade, (1977): p602-603

<sup>2</sup> C. W. 8: 800



throughout Blade Runner there is almost constant rain, and nearly always the viewer can see or hear rain falling. This may provide a clue as to where to look for the mythological parallels to the mythologem, and perhaps there is a connection between the constant rain in Blade Runner and flood myths.

For example there is the Hindu myth of how Manu survived the flood:

'When he was washing himself, a fish came into his hands. It spake to him the word "Rear me, I will save thee!" "Wherefrom wilt thou save me?" "A flood will carry away all these creatures: from that I will save thee"... he attended to (the advice of the fish) by preparing a ship; and when the flood had risen, he entered into the ship... The flood swept away all creatures, and Manu alone remained here'.<sup>1</sup>

There is also the Babylonian flood-creation myth told to Gilgamesh, after he had crossed over the sea of death, by Ut napishtim. (Even in the telling of the story death and creation are linked).

'The wide land was shattered like a pot! For one day the south storm blew, submerging the mountains, overtaking the people like a battle... When the seventh day arrived the flood (carrying) south storm subsided in battle... And all mankind had returned to the clay... The dove was sent forth, but came back; there was no resting place for it and she turned round...'<sup>2</sup>

One final example of the flood-creation myth is the Noah myth, and here, as in the myths cited above, the already created world is wiped out by a flood. The now purged earth is then repopulated by the animals and people saved in the ark or ship.

'The waters rose and covered the mountains to a depth of more than twenty feet. Every living thing that moved on the earth perished - birds, livestock, wild animals, all the creatures that swarm over the earth, and all mankind... Then God said to Noah, "Come out of the ark, you and your wife and your sons and their wives. Bring out every kind of living creature that is with you -the birds, the animals, and all the creatures

---

<sup>1</sup> Eggeling, J., Trans. The Sacred Books of the East, (Oxford, 1882): p216-218

<sup>2</sup> Speiser, E. A., trans. Ancient near Eastern Texts, (Princeton, 1950): p60-72

that move along the ground - so they can multiply on the earth and be fruitful and increase in number upon it".<sup>1</sup>

It will no doubt be remembered that, as in the Gilgamesh flood creation myth, a dove is sent from the ark. The symbolism of the dove will be explored in detail in the myth/mythology section. But it is worth noting that the dove,<sup>V</sup> along with the water symbolism, provides a link to the initiation ritual of baptism. In this Christian ritual water is thought of as washing away the old life so that one can be 'born again' into a new life in Christ, and it was at the baptism of Jesus that the Holy Spirit descended in the form of a dove. 'As soon as Jesus was baptised, he went up out of the water. At that moment heaven was opened, and he saw the Spirit of God descending like a dove and lighting on him'.<sup>2</sup>

The Christian tradition is not alone in possessing an initiation ritual using water. For example there is Diksha a Hindu initial ritual of rebirth,<sup>VI</sup> and from a Western source there is the Irish myth of Cuchulainn's initiation.<sup>VII</sup> But these are only two possible myths from many.

In the search for parallels to the central myth it is interesting and helpful to briefly examine the storm images from Shakespear's King Lear. The central and pivotal act of the play occurs during a storm and Lear, at this point, is a broken man. He has fallen from monarchy to the state of naked humanity, however he will move through this phase to achieve a greater depth of human understanding. The ambiguity to this situation is that when Lear was a ruling monarch he in fact controlled nothing while here, in his madness, he calls upon the elements to destroy the world.

---

<sup>1</sup> The Bible. New International Version. Genesis 7: 20-21, and 8: 15-17, (London, 1979)

<sup>2</sup> The Bible, Matthew 3: 16

'Blow, winds, and crack your cheeks! rage! Blow!  
 You cataracts and hurricanes spout  
 Till you have drenched our steeples, drown'd the cocks!  
 You sulphurous and thought-executing fires, ...  
 Strike flat the thick rotundity of the world!<sup>1</sup>

This type of apocalyptic imagery is similar to that at the start of Blade Runner where, despite the rain, jets of fire leap into the sky.<sup>VIII</sup> Lear needed the storm to wash away the old psyche, or in apocalyptic imagery to destroy the old Lear, so that a different person could emerge the other side of the storm. It would seem that this is not unlike Decker's need for psychological development, and the storm imagery of King Lear is similar, albeit more violent, to the rain imagery in Blade Runner and to that of the parallel myths cited above.

It would seem that the themes of Blade Runner are concerned not only with individual renewal but also with creation/recreation on a cosmic scale. the fact that rain is constantly falling over the city may symbolise this universal dimension. As if to emphasise this the film opens with a night shot of rain and lightning over all the city. Thus a hero, Decker, is elected to face in microcosm the life, death, life process of his personal individuation, so that he is able to aid in the macrocosm of the culture's individuation process. Much as the Christ hero died to save the world so Decker dies to the old self to aid his society. Interestingly at the end of the film Roy, the warrior, extracts a nail from a piece of wood and plunges it into the palm of his hand, deliberately creating the marks of the stigmata. And Decker, as already noted, has to pass on to the next stage leaving the dead and crucified Roy behind.

---

<sup>1</sup> Shakespeare, W., King Lear Act III, Scene II, line 1-9

MYTHOLOGY AND MYTHOLOGEM

It seems appropriate to start this section with a reminder of the importance of symbols, and later in the thesis there will be a detailed theoretic assessment of their significance. Until then the following quotation may prove helpful.

'We only understand that kind of thinking which is a mere equation, from which nothing comes out but what we have put in. That is the working of the intellect. But besides that there is thinking in primordial images, in symbols which are older than the historical man, which are inborn in him from the earliest times, and, eternally living, outlasting all generations, still make up the ground work of the human psyche. It is only possible to live the fullest life when we are in harmony with these symbols; wisdom is a return to them'.<sup>1</sup>

In the following analysis of the symbols in Blade Runner it is hoped to demonstrate that while all symbols contain a variety of possible interpretations, and by their nature seek to reconcile opposites, it is possible to detect a unifying theme. The symbolic theme in Blade Runner supports the mythologem in that it is permeated with symbols concerned with growth through contradiction, for example, death to life, or reality to illusion.

The first symbol to be identified in Blade Runner is the constant rain;<sup>IX</sup> this symbol has already been analysed in some depth and it has been shown how the narrative can be connected to the flood creation myths. Decker, like all others in the city, suffers from the effects of the rain, and if he is to survive this symbolic flood then he must move forward in his individuation. One of the symbols for Decker's ongoing individuation is the eye, and through several close-ups the film draws attention to this key symbol. (Eyes are very important in Blade Runner because, with the use of 'void comp' equipment, they are the way in which a replicant can be detected). Eyes indicate sight, but in the world of symbols opposites are uni-

---

<sup>1</sup> C. W. 8: 794

fied and the eye indicates outward conscious sight but inward blindness. In other words Decker has no 'insight'.

It is a cliché that 'eyes are the windows of the soul' but in the case of the replicants this observation seems valid. They have no soul, no feelings, no emotion, they are outwardly human but inwardly cold and alien. A mythological echo of this ambiguity is found in Psalm 15, 'They have mouths, but cannot speak, eyes but cannot see'.<sup>1</sup> (Again the wise old man in his strange silence is called to mind). Because of their inability to feel, the replicants are blind to reality, much as Decker is blind to the reality of life's ambiguities and illusions. If he is to progress with individuation, he must accept the paradoxical and illusory aspects of his psyche, and this involves accepting the objective psyche with its symbolic communications. (It will be remembered that symbols paradoxically seek to reconcile oppositions, and that ultimately their interpretation is subjective).

It may prove illuminating to briefly return to King Lear where Gloucester, because of his blindness to what happens in the world, has his eyes gouged out and he comments, 'I have not way and therefore want no eyes; I stumbled when I saw'.<sup>2</sup> It would seem that Decker needs this type of insight. Again, but this time returning to oriental sources, the Buddha comments, 'The eye, O priests, is on fire; forms are on fire; eye-consciousness is on fire; impressions received by the eye are on fire'.<sup>3</sup> This seems applicable to the film's imagery especially at the start of the film,<sup>X</sup> and it indicates a need for a change in Decker's conscious awareness. Images and forms received from the eye are on fire, the old illusions are destroyed and hence the illusions can be transcended in an acceptance of their illusory qualities. The ambiguous

---

<sup>1</sup> The Bible, Psalm 115, Verse 5

<sup>2</sup> Shakespeare, King Lear, Act IV, Scene I, line 19

<sup>3</sup> Buddha, The Fire Sermon. From: The Teachings of the Compassionate Buddha, ed. E. A. Burtt, (New York, 1955). This edition, (New York, 1982): p97

qualities remain, despite being covered in flames.

It is with this realisation that Decker starts his quest in Chinatown. In detective films this is traditionally a place of crime, wisdom, treachery and yet security. The detective seems peculiarly at home in such a place, perhaps due to its closeness to the 'mystical east'. In Blade Runner's Chinatown the atmosphere is claustrophobic and polluted, the people talk in 'city speak', a babbling conglomeration of Western and Eastern languages. The chaos in the city calls to mind the Biblical myth of the tower of Babel.<sup>XI</sup> This Babylonian imagery provides a link back to the flood creation myths, two of which came from Mesopotamia, and forward into the film's developing imagery, as the first place Decker visits on his quest for individuation is the Ziggurat of the Tyrell Corporation.<sup>XII</sup>

The Ziggurat, a typical Babylonian religious building, with its stepped sides symbolically depicts man's upward climb to search for spiritual truth. However its highest point, the roof, is empty, ultimately nothing is found - Imago ignota. Inside the Tyrell building the atmosphere of Mesopotamian religion is continued with a pyramidal background and a warm yellow light.<sup>XIII</sup> The atmosphere is charged with the numinous. It is in this semi-divine environment that Decker first meets Rachel, who as discussed above, represents a projection of his anima's positive aspects. By series of close-ups our attention is also drawn to an owl, the first of three important and symbolic animals in Blade Runner.

It is worth noting how dominant this theme of illusion is in Blade Runner. Even two of the important symbolic animals, the snake and the owl, are replicants, in other words they are unreal animals. This is made explicit in the close-up of the owl<sup>XIV</sup> where again it is the strangeness of the eye which reveals the owl as a replicant.

The own contains in its symbolism wisdom and its opposite: foolishness.

However it may also symbolise death,

'On a Sumerian tablet dating from 2300-2000 B.C. a nude goddess is depicted flanked on either side by an owl. She is believed to be the goddess of death... In Semitic countries the owl is usually regarded as ominous and in Persia is spoken of as "the angel of death..."'<sup>1</sup>

As might be expected the owl also symbolises the opposite of death, new life and procreation. '... in Israel little grey owls are considered good omens when they appear near the crops'.<sup>2</sup> In addition Chetwynd draws attention to the goddess Athene, whose closest animal was the owl, and he adds that Athene is the, 'personification of the anima'.<sup>3</sup> Thus the reading of Rachel as Decker's anima seems reinforced, and it would further appear that the symbolic structure is in accord with the mythologem and archetypal pattern.

The second important symbolic animal that is encountered is the snake. After Decker has recognised his replicated anima, he returns into the city to start the individuation process and retire those now redundant parts of his psyche. He first finds Zhora the sensation aspect of his ego, and she is depicted as being a dancer with a snake in an erotic cabaret show. Clearly there is reference to the Eden myth and the figure of Eve, and Zhora like Eve is associated with the snake. However the symbolism of the snake is varied. For example, it can move on both land and water, which are images of the conscious and unconscious respectively. The flying snake may symbolise the liberated anima, and there is also the Gnostic image of the Uroboros, which depicts a snake eating its tail. The opposition in the Uroboros is clear, like Decker the snake renews its self by destroying the old self, by eating its body, and for Decker this self destruction takes

---

<sup>1</sup> Warner, R., Encyclopedia of World Mythology, (London, 1970): p220

<sup>2</sup> Warner: p220

<sup>3</sup> Chetwynd, T., A Dictionary of Symbols, (London, 1982): p36

the form of retiring replicants. Again apparent contradictions in the symbol in fact inform as to the archetypal pattern and mythologem.

The next important symbolic animal does not occur until the end of the film when Roy the warrior dies. It is at this moment that he releases a dove.<sup>XV</sup> The symbol of the dove unites several of the subthemes in Blade Runner. First it unites the flood creation myths as both Noah and Gilgamesh send out doves from their arks in search of dry land. This idea of recreation is carried through into the concept of baptism where the holy spirit is received, and as already mentioned at Jesus' Baptism this took the form of a dove. Thus the dove symbolises both rebirth into new life and the holy spirit. It is interesting to note that the Greek word for spirit, also meaning either wind or air, is pneuma. (This will be returned to shortly). The Hebrew word for the same concept is Ruach, and it was this Ruach that hovered over the surface of the deep in the first Genesis creation myth, and the Latin for the concept of spirit is anima. So through the symbol of the dove it is discovered that anima is the concept which unites the themes of creation, death, life and rebirth.

#### INDIVIDUATION PROCESS

It should be clear by now that the process which unifies all the themes, symbols and concepts in Blade Runner, is the individuation process. This is represented in the theme of the quest, in the creation-recreation myths and in the initiation myths. What follows is an analysis of Decker's individuation process and what stage he has reached by the end of the film. After Roy releases the spirit/dove, Decker is free to accept his anima. Apparently he does this and the final shots of the film are of Decker and



Rachel flying through the air, or Pneuma/Ruach.<sup>XVI</sup> Perhaps they have become as 'one in the spirit', and it has also stopped raining as now they are in the temperate regions of the, seemingly individuated, psyche. At this point it is also revealed that Rachel, unlike the other Nexus six replicants, does not have an incept date, consequently no one knows how long she will live. Perhaps the message is that the spirit lives eternal.

To give added weight to this reading which equates the closing of the narrative with the completion of a stage in the individuation process, it is proposed to briefly examine the creations of Gaf, the wise old man character in Blade Runner. Gaf creates three small pieces, these are: a bird, a matchstick man, a unicorn, and they are left by him at different points in the film. (The bird and unicorn are origami pieces while the matchstick man is made from a match. With the origami pieces there may be an extra reference to the creation myths, as it is from only one square of paper each that the bird and unicorn are created). The creation of the bird comes first and it seems to refer to Decker's potential freedom, it also pre-echoes the symbolism of the dove which occurs at the end of the narrative. The matchstick man may refer to Decker having to accept the many aspects of the psyche which make him human. However the unicorn is the most interesting symbol and this occurs almost immediately after the dove at the end of the film.

According to Jung, 'In Christian picture-language the unicorn, as well as the dove, is a symbol of the spermatoc Word or Spirit'.<sup>1</sup>

Gaf seems to have known the need for Decker's individuation, as when he visited Decker's flat, he did not retire Rachel who was sleeping there, but instead left a symbol of Decker's future life in the spirit.<sup>XVII</sup>

---

<sup>1</sup> C. W. 5: 492

However the symbol of the unicorn is more complicated than this, and as Jung notes,

'The horn of the unicorn acts as an alexipharmic, because it expels the poison from the water, and this refers allegorically to the baptism of Christ... rightly is it applied to Christ baptized, who, like the chosen son of unicorns, sanctified the streams of water to wash away the filth of all our sins'. XVIII, XIX

But in this final section of the film there remains an ambiguity, has Decker really achieved individuation or not? From the above reading it is tempting to conclude that he has reached the anima stage of individuation but this is by no means certain. Rachel, as a personification of his anima, still exists as a separate entity, she does not yet live in him. Also Decker still tries to tell Rachel what to do, 'trust me' he requests, so rather than trusting in her, he trusts himself and requires her to do the same. There is a sense in which he seems stuck at the anima stage, perhaps he is on the road to individuation but not at its end - his quest has yet to be completed. At this point in his life Decker seems content to live with illusion, he exchanges the illusions of the city for the illusion of super lush countryside valley. (The first 'natural' sequence of the film). Perhaps this environment is better suited to the anima nature of the woman/spirit Rachel? As already stated Decker does not know how long Rachel will live. Is he anxious about this? Does this indicate some future development in their relationship? These questions remain unanswered and perhaps that is right, for when dealing with symbols and the unconscious there is always ambiguity.

However, by the end of the film the tone seems optimistic, Decker has done well on his quest, he has progressed well down the road, who is to say he

---

<sup>1</sup> Caussin; N., De Symbolica Aegyptiorum Sapientia, Polyhistor Symbolicus Electorum Symbolorum, et Parabolarum historicum Stromata, (Paris, 1618 and 1631): p348, cited in, C. W. 12: 522f

will not achieve individuation? As the Tao remarks,

'The valley spirit never dies.  
It is named the Mysterious Female.  
And the Doorway of the Mysterious Female  
Is the base from which Heaven and Earth sprang.  
It is there within us all the while;  
Draw upon it as you will, it never runs dry'.<sup>1</sup>

### CONCLUSION

In the film it is the symbolic images, of water, baptism, cleansing, (here symbolised in Christ) which are brought forth and joined in the theme of rebirth. All the different strains in the film seem united in the main theme which is a representation of the individuation process. It would also appear that the analytical archetype model has enabled the discovery of a series of latent mythological themes. These themes connect in a coherent, but hidden manner, with the symbolic structure of the film, and this provides Blade Runner with a unified but concealed form. Further, underlying all these elements, the model has identified a representation of one stage in the individuation process, and has revealed the contrasexual archetype anima, as vital to the successful completion of individuation. It has also been demonstrated how this links to the subsidiary theme of illusion. Ultimately the hero is seen as someone who experiences, on the behalf of a society, the individuation process. On a cultural scale this indicates a latent unconscious need for individuation which the film, in some small way, both compensates for,<sup>XX</sup> and expresses.

One of the interesting areas in Blade Runner is the role that symbols have within the film. The next chapter, which explores this theme, is a theoretical examination of how analytical psychology regards the symbol. The

---

<sup>1</sup> Tao de Ching, in Eliade (1977): p595

chapter also applies this theory directly to film analysis, and consequently both the theoretical base and practical application of the model are developed.

CHAPTER FIVE NOTES

- I. Origami being the traditional Japanese pastime of paper folding.
- II. c.f. Appendix I, f
- III. c.f. Appendix I, c
- IV. Medusa too was concerned with illusion. She was the only mortal of the three Gorgan sisters and all who saw her turned to stone, as a result she could only be looked at safely via a mirror. Only her reflection, that is her illusion, was safe.
- V. c.f. Appendix I, g
- VI. c.f. Eliade, M., Birth and Rebirth, (New York, 1958): p54
- VII. c.f. Eliade, (1958): p85
- VIII. c.f. Appendix I, a
- IX. For a detailed discussion of what constitutes a symbol, c.f. The Symbolic Search: p159
- X. c.f. Appendix I, a
- XI. c.f. Genesis 11
- XII. c.f. Appendix I, b
- XIII. c.f. Appendix I, c
- XIV. c.f. Appendix I, d
- XV. c.f. Appendix I, g
- XVI. c.f. Appendix I, h
- XVII. It seems only reasonable to indicate that on a few occasions the unicorn can symbolise evil, but here that does not seem to be the case. (c.f. C. W. 12: 525).
- XVIII For a detailed account of the unicorn's symbolic role, c.f. C. W. 12: 518-554
- XIX. As a point of information there is some evidence to suggest that the fish Manu hooked, cited above was unicorned. c.f. C. W. 12: 533
- XX. In as much as all communications of the objective psyche exist in a compensatory attitude to ego-consciousness, so too this film should be regarded as compensatory, to the collective ego-consciousness.

Chapter Six

The Symbolic Search

INTRODUCTION

This chapter has two functions. First it provides a detailed examination of what analytical psychology means by the term 'symbol' and secondly it applies this theory to the analysis of two detective films. In the first section the general context for understanding the symbol is established and this leads to a specific psychological consideration of how symbols relate to the objective psyche. Having established this theoretical base, which provides some of the background to the analytical model presented in Chapter Four, it is possible to progress to the application of this theory in film analysis. The two films chosen are Sleuth (Dir. J. L. Mankiewicz, Fox, Rank, 1972) and Woman in the Window (Dir. F. Lang, RKO, 1944). The analysis of specific symbolic passages in these films indicates how they give expression to apparent oppositions within the narrative, and also how they prepare the way for the psychological development of the film's central characters.

A CONTEXT FOR THE UNDERSTANDING OF SYMBOLS

For contemporary Western man a mechanistic rationalism provides the dominant structure for his thought. This structure emerged in the Sixteenth and Seventeenth Centuries and with it came the dominant image of the 'world machine'. In this image the world was conceived in mechanistic terms and thought of as a large and intricate piece of celestial engineering. This view pervades the scientific discoveries of Galileo, the philosophical dualism of Descartes and later the observations of Newton and Darwin.<sup>1</sup> It also extends to the modern psychologies of psychoanalysis, behaviourism and cognitive psychology. As a result of this the behaviourist Skinner is able to write, 'What we need is a technology of behaviour... comparable in power and precision to physical and biological technology'.<sup>1</sup>

However there is a growing dissatisfaction with the mechanistic paradigm and recently it has been extensively criticised by such writers as Bateson, (1972, 1979), Sheldrake, (1981), Capra, (1975, 1982). What is emerging from their criticisms is a new holistic systemic paradigm. From the Jungian perspective this insight comes as no surprise. As Capra has commented,

'Indeed, it seems that Jung's approach was very much on the right lines and, in fact, many of the differences between Freud and Jung parallel those between classical and modern physics, between the mechanistic and holistic paradigm'.<sup>2</sup>

Throughout his writings Jung is anxious to stress that rationalism is an attitude which lacks both the capacity for introspection and symbol formation. The reasoning behind this generalisation is that the symbol can only be formed, or released, from the unconscious when an introverted non-

---

<sup>1</sup> Skinner, B. F., Beyond Freedom and Dignity, (New York, 1975): p3

<sup>2</sup> Capra, F., The Turning Point, (London, 1982). This edition, (London, 1987): p397



rationalistic approach is adopted. This is consistent with his insight that the objective psyche provides the basis for psychological development and regulation. Consequently if a psychologically healthy life is to be pursued, then attention must be paid to our inner lives.

In the following quote Whitmont states the classical Jungian position.

(It is important to note that when he uses the term 'image' he is referring specifically to the symbolic image).

'Not only is the presence of the image not pathology but the loss of awareness of the image dimension (which is the loss of contact with inner reality, as we shall see) gives rise to pathology'.<sup>1</sup>

What Whitmont means by this is that an awareness of symbols is essential to psychological development. Thus from the perspective of analytical psychology it is important to adopt, at least to some degree, an introverted attitude, as this is how the symbol is released into ego-consciousness.

Jung constantly stresses the poverty of rationalistic reasoning and is insistent that in the final analysis it is only the symbol which can connect man with his deepest and most fundamental problems. As he comments,

'Reason must always seek the solution in some rational, consistent, logical way, which is certainly justifiable enough in all normal situations but is entirely inadequate when it comes to the really great and decisive questions. It is incapable of creating the symbol because the symbol is irrational. When the rational way proves to be a CUL DE SAC - as it always does after a time - the solution comes from the side it was least expected'.<sup>2</sup>

Jung was also concerned that while the old symbols were dying, society was not generating new symbols which could take their place. He felt that some-

---

<sup>1</sup> Whitmont, E. C., The Symbolic Quest, (Princeton, 1978) p27

<sup>2</sup> C. W. 6: 438

how Western society had disconnected itself from the unconscious, and that rationalism was to blame for this occurrence. Therefore a vital part of Jung's endeavours was to reconnect modern man with his psychological heritage, that is with the objective psyche.

'I am convinced that the growing impoverishment of symbols has a meaning. It is a development that has an inner consistency. Everything that we have not thought about, and that has therefore been deprived of a meaningful connection with our developing consciousness, has got lost'.<sup>1</sup>

The principal way he found of discovering this lost heritage was through myths, and also through the symbols contained within these myths. Jung was able to find a series of myth motifs, whose archetypal patterns he felt were latent in the objective psyche. And in clinical work it became the task of the analyst to help the patient recognise these myths and to assimilate their archetypal patterns and the symbols into ego-consciousness.

It is because of the above considerations that in the analytic model established in Chapter Four, the symbol is not seen in isolation. Rather it is seen as part of a mythological and psychological process. The advantage of this is that it responds to the need for a holistic approach and uses the environment of the myth to assist in understanding the symbol's meaning, while analytical psychology assesses its function.

Initially it might seem from Jung's remarks that he believed contemporary Western society to be devoid of symbolic products, but this was not the case. What he claimed was that the conscious life of Western society is sterile, but under the surface, in the unconscious there is a hidden life and it is here that the myths and symbols survive. This explains the apparent contradiction of finding symbols in films, in a society that from

---

<sup>1</sup> C. W. 9, I: 28

the Jungian perspective is essentially without symbols. The films seem to have become expressions of the objective psyche, and it is a consequence of this that the psychology of the society is reflected in its films. As Jung has poetically commented,

'Since the stars have fallen from heaven and our highest symbols have paled, a secret life holds sway in the unconscious. That is why we have a psychology today, and why we speak of the unconscious... Our unconscious, on the other hand, hides living water, spirit that has become nature and that is why it is disturbed. Heaven has become for us the cosmic space of the physicists, and the divine empyrean a fair memory of things that once were. But "the heart glows," and a secret unrest gnaws at the roots of our being'.<sup>1</sup>

#### THE SYMBOL AND THE OBJECTIVE PSYCHE

In examining how symbols operate within the psyche, it is important to first provide some indication of what analytical psychology means by this term. For Jung the symbol is quite different from its everyday counterpart the sign, and perhaps the main distinction between the two is that a sign indicates something which is immediately present while a symbol refers to something which is outside of the moment, it is unknown and contains unconscious elements. An alternative way of making this distinction would be to say that a sign is an image which is understood by ego-consciousness while a symbol is an image which as yet remains uncomprehended by ego-consciousness. The ego is attracted to the symbol, and is able to grasp part of its meaning, but total comprehension of the symbol lies beyond its range. As Jung notes,

'A term or image is symbolic when it means more than it denotes or expresses. It has a wider "unconscious" aspect - an aspect that can never be precisely defined or fully explained. This peculiarity is due to the fact that, in exploring the symbol, the mind is finally led towards ideas of a transcendent nature, where our reason must capitulate'.<sup>2</sup>

---

<sup>1</sup> C. W. 9, I: 50

<sup>2</sup> C. W. 18: 417

Here the most important point is that symbols 'lie beyond the grasp of reason' and hence they cannot be fully understood by the rational part of the psyche, which is ego-consciousness. In fact if an attempt is made to rationally understand a symbol, then it may become corrupted and cease to be effective. As Jung has observed,

'A symbol loses its magical or, if you prefer, its redeeming power as soon as its liability to dissolve is recognised. To be effective, a symbol must be by its very nature unasailable'.<sup>1</sup>

Of course symbols may be used by the conscious, or rational, part of the psyche. Many religions in their highly conscious symbolic imagery demonstrate this type of conscious symbolic construction, and one example of this is the elaborate and highly structured nature of the Christian eucharist. Here the signs of bread and wine are transformed to symbolise the 'real presence' of the body and blood of Christ. So within a consciously constructed ritual the process of symbolic transformation takes place, that is the move from sign to symbol occurs.<sup>II</sup> (However even here it is important to note that complicated unconscious factors such as 'projection' and 'participation mystique' are brought into operation by the priest and congregation, and without this these symbols would lose much of their value).

Within analytical psychology it is not the normal practice to regard symbolic imagery as available for the manipulation of ego-consciousness, and the reason for this is that the symbol is composed of unconscious elements. Instead symbols are regarded as spontaneous communications from the unconscious, that is both the personal unconscious and the objective psyche. This distinction between the two types of unconscious is important because it is possible for an individual to release a symbol that has meaning only

---

<sup>1</sup> C. W. 6: 401

for them. As an example an apple may assume a symbolic significance for an individual although other people may be quite unaware of these special individual symbolic associations, and as a result of this they will remain mystified as to why the apple is held in such high esteem. These individual symbols may present themselves in a variety of ways including dream imagery, painting, film, etcetera, and from these representations it may be possible to draw conclusions about their creator's personal unconscious. For example from the symbols found in a film, or series of films, it could be possible to make some deductions about the director's psyche.<sup>III</sup> This type of symbol is properly the property of the personal unconscious, and as such is not really of relevance to this thesis. Here what is of concern, are the more general, or 'universal' symbols which originate from the objective psyche.

An example of this type of universal symbol is water, and within its symbolic breadth it contains a diversity of meanings for example; baptism, purification, castration, regeneration, the objective psyche, danger, death etcetera. Jung has placed a special significance on these types of symbols and he regards them as fundamental to our humanity, that is vital to the successful progress of the individuation process.

'But besides that there is thinking in primordial images, in symbols which are older than historical man, which are inborn in him from the earliest times, and, eternally living, outlasting all generations, still make up the groundwork of the human psyche. It is only possible to live the fullest life when we are in harmony with these symbols; wisdom is a return to them'.<sup>1</sup>

As can be seen from the previous quote Jung regards the process of symbol formation, and subsequent liberation, as psychologically important. The

---

<sup>1</sup> C. W. 8: 794

symbol may be formed from either inner unconscious images or it can be a translation of everyday images. In the latter case objects which surround us in the world are abstracted and become transformed into the property of the unconscious. (Like the bread and wine mentioned in the Christian Eucharist). As a result of this, these images become symbols of an inner life, rather than signs of an outer world.

Further it is part of the work of the individuation process to incorporate both types of symbols into the functioning of ego-consciousness. In other words as part of the individuation process the individual has to become aware, that is conscious, of his or her own processes of symbolic formation, liberation and transformation. However even once these symbols have been brought into ego-consciousness they remain ultimately unknowable.

'Moreover apperception translates the observed fact into a seemingly (incommensurable) medium - into a psychic event, the nature of which is unknowable. Unknowable, because cognition cannot cognize itself - the psyche cannot know its own psychic substance'.<sup>1</sup>

These psychic events whose ultimate nature is unknowable have become transformed into psychological symbols. The symbols are not synonymous with rational thought, in fact they seek to communicate what rational thought, that is ego-consciousness, cannot communicate. As symbols they are neither rational or irrational, but rather they are non-rational; and they are a way of presenting concepts which apparently lie beyond the reasoning abilities of ego-consciousness. These non-rational communications which the conscious mind is unable to understand, belong to the intuitive and unconscious parts of the psyche and as Jung has commented,

---

<sup>1</sup> C. W. 18: 419

'But the (psychic) event can also manifest its unconscious aspect - and this is usually the case - in a dream. The dream shows this aspect in the form of a symbolic image and not as rational thought'.<sup>1</sup>

In turn these 'symbolic images' are liberated by and from the objective psyche. Here it can be seen why Jung preferred the term 'objective psyche' to the more popular notion of the collective unconscious. The objective psyche is objective because it is independent of the personal unconscious and ego-consciousness, also it liberates symbols which offer 'objective' advice and guidance to the psyche. It is this advice, if it is heeded by ego-consciousness, which assists in the progress of the individuation process.

The symbol, as the property of the unconscious, communicates what ego-consciousness cannot. Therefore the symbol originating from the depths of the unconscious exists in a compensatory attitude to ego-consciousness<sup>IV</sup> and possesses both a universal or collective meaning, and a personal meaning, as each individual liberates the symbols they need for their own individuation. As Jung writes,

'The symbol is thus a living body, corpus et anima; hence the "child" is such an apt formula for the symbol... In this sense I hold Kerenyi to be absolutely right when he says that in the symbol the world itself is speaking. The more archaic and "deeper," that is the more physiological, the symbol is, the more collective and universal, the more "material" it is'.<sup>2</sup>

It will be remembered that the individuation process involves the integration of the conscious and unconscious aspects of the psyche into a unified whole. As the objective psyche is a constructive element in individuation, its symbolic communications should be both observed and encouraged, for by

---

<sup>1</sup> C. W. 18: 420

<sup>2</sup> C. W. 9,I: 291

attending to the symbolic function the psyche can proceed with its individuation. In other words the symbol can be thought of as something which combines both the conscious and unconscious elements. While it emanates from the objective psyche, it must also be partly comprehensible to ego-consciousness, otherwise it could have no meaning, yet at the same time its fullest meaning will always remain hidden in the depths of the unconscious. As Jung has commented, 'The symbol is the middle way along which the opposites flow together in a new movement, like a watercourse bringing fertility after a long drought'.<sup>1</sup>

The objective psyche appears in a variety of forms, not just as a symbol, and as a result of this it can prove very difficult to recognise. It may appear in archetypal dreams disguised as an 'evil woman' or a 'wise old man' or maybe a 'speaking animal'.

However underlying these appearances of the objective psyche, there is a general principle which aids the analyst in his/her attempts to recognise and understand its actions. This general principle is relevant to an understanding of the symbol because, as mentioned, symbols originate from the objective psyche. The Jungian analyst Whitmont has commented on this principle by saying that,

'At best we can speak of it indirectly by describing human behaviour - the behaviour of others and also our own subjective experience, as if a potential, encompassing wholeness were ordering the action of the parts'.<sup>2</sup>

Therefore one of the important functions of the objective psyche is that it orders and liberates the potential for a wholeness of the psyche, which is

---

<sup>1</sup> C. W. 6: 443

<sup>2</sup> Whitmont: p15



the individuation process.<sup>V</sup> Symbols play a vital role in individuation as they form the bridge between the unconscious and conscious parts of the psyche. Thus the potential for a united psyche is presented symbolically.

Before proceeding to the analyses of symbols in films there is a brief summary of the key points of this chapter. This both crystallises the central concerns of this section and points towards the analyses of the films by giving a hint of what might be found there.

### Summary

- 1) The symbol is different from the sign, one of the distinctions is that the symbol cannot be comprehended by ego-consciousness.
- 2) Symbols take an active role in the individuation process, and guide in a compensatory manner. (They may also symbolise wholeness of the psyche - the mandala).
- 3) Symbols are the products of the unconscious and expose levels of the unconscious which would otherwise remain hidden.
- 4) The symbol can never be fully understood.

THE SYMBOL IN FILM

This section of the chapter applies the theory of the symbol, which was discussed in the previous section, and does so in an effort to critically analyse the role that symbols have within film. It will show that the symbol is a uniting force which draws together and expresses tensions within the film text. Either it acts as a summary of what has gone before, or prepares the ground for what is to come. As the symbol by its nature contains opposition, that is it mediates between consciousness and the unconscious, the known and the unknown, it may fulfill both of the described roles. In other words it is possible for the symbol to represent the fundamental oppositions within the film, be they oppositions of myth, narrative or psychology.

The above points will be demonstrated by examining a passage from two detective films. These passages will then be placed in the context of the larger film text, while at the same time there will be an exploration of the symbol's mythological heritage. This will result in placing the symbol within both its filmic and mythological contexts and, in keeping with the analytical model, these factors will be seen within the framework of analytical psychology which will provide an additional method by which the function of the symbol can be described.

In this section the first film to be examined is Sleuth (Dir. J.L. Mankiewicz, Fox, 1972). The passage that will form the centre for this analysis is the opening sequence in which Milo Tindel (Michael Caine) attempts to find Andrew Wyke (Laurence Olivier) who has concealed himself at the centre of a labyrinth. However first there is a brief plot synopsis as this will provide a background for the extracted sequence.

Milo Tindel arrives at an English country house in search of Wyke and his intention is to ask permission to marry his wife, Taya whom Wyke is no longer seeing. Wyke persuades Tindel that in order to keep his would-be-  
 bride in the style to which she is used he will need vast financial resources and suggests an insurance fraud as a means of raising the money. He describes a plan in which Tindel dressed as a clown, is to rob his safe. He could then fence the jewels and Wyke could claim the insurance. Tindel agrees to this, but Wyke's real plan is to use the imaginary robbery as a way of murdering Tindel. Wyke shoots Tindel with a blank, although Tindel does not realise this and passes out. Two days later Tindel returns disguised as a police inspector to extract his revenge by playing an equally macabre game. Here he has framed Wyke for the murder of Taya. Eventually he reveals himself, and is then really shot by Wyke, who then hears the police sirens at his door. The last words of the film are uttered by the dying Tindel, 'Andrew, don't forget be sure to tell them it was just a bloody game'. The curtain comes down, and the final act of the narrative is over.

As mentioned, the specific passage under consideration is the opening sequence of the film. Here Tindel enters a labyrinth in the garden of Wyke's house. Its entrance is guarded by a large stone snake and its paths contain many stone statues of mythological beasts and large reflecting mirrors. Eventually he finds his way to a hedge which is swung open by Wyke to reveal the centre of the maze, what Wyke calls his 'outdoor inner sanctum'. And this further establishes the numinous quality of this space. Throughout this search there is a voice over of Wyke narrating the end of a detective story that he is writing, and so, in typical symbolic fashion, the end of one narrative marks the start of another.

In many ways the symbolic image of the labyrinth prefigures much of what is to happen in the film. The viewers are alerted to expect a narrative which like the labyrinth, will possess many intricate pathways, concealed alleys with hidden horrors, and they are not disappointed. In fact the viewer of the film is encouraged to participate in the game of unravelling the maze like narrative, which is not unlike the more macabre intellectual games that are played on screen. Indeed the viewer becomes a type of detective and so in a way he joins the Master Game player Wyke and his apprentice Tindel. (Perhaps the best player is the viewer who having solved the puzzle of the narrative, and thereby vicariously played the game with his own psyche, is free to leave the cinema).

Within mythology the labyrinth is associated with death and this is also true in Sleuth in which the narrative revolves around murder, both real and illusory. This association between death and the labyrinth is evident in many myths, not least of which is the famous myth of Theseus and the Minator. Another is the Melanesian myth in which the souls of the dead are carried across the waters of death to approach the entrance to the underworld.

'... it (the soul) perceives a female guardian sitting before the entrance, drawing a labyrinth design across the path, of which she erases half as the soul approaches. The voyager must restore the design perfectly if he is to pass through it to the Land of the Dead. Those who fail, the guardian eats'.<sup>1</sup>VI

From this it can be seen that at least one way of entering the underworld, which psychologically is the underworld of the objective psyche, is via a labyrinth. Both Tindel and the film's viewer are initiated into the world and this is signalled by the gruesome games that are played and the murder that is committed. It is clear that this type of deathly deception is the property of Hades.

---

<sup>1</sup> Campbell, J., Primitive Mythology, (New York, 1959). This edition, (London, 1984): p68-69

From a mythological and symbolic perspective it is no surprise that the entrance to the labyrinth in Sleuth is guarded by a large stone snake. Traditionally the snake is the sacred animal of the labyrinth<sup>VII</sup> although it was later replaced by the pig, the bull and finally the horse. This association is very ancient and Campbell cites an example of this relationship between the snake and the labyrinth from paleolithic symbolism.

'The symbolism of the serpent of eternal life appearing in the paleolithic period as the reverse of a plaque bearing on its obverse the labyrinth of death...'<sup>I.VIII</sup>

The labyrinth in Sleuth is therefore a complex symbol which contains within its paths two principal oppositions which are death and life. The initiate must learn its paths, for the point of a labyrinth is to find the way to its centre, and to then search for the exit. In other words the point of the labyrinth is to enter it, only to leave it again. In psychological terms the symbolic act of entering the labyrinth, and the labyrinth itself, are symbols of the individuation process.<sup>IX</sup> And the paths represent the difficult and quasi magical mythological underworld that all who accept the work of individuation enter. Colli has brought together many of the elements that Sleuth also brings together, most notably the ideas of game playing, numinosity and the labyrinth. He comments that,

'The geometric form of the labyrinth with its unfathomable complexity, invented through a bizarre but perverse game of the intellect, alludes to ruin, to the world peril that lies in wait for man when he dares to confront the animal god'.<sup>2</sup>

Entering the labyrinth is to enter the underworld of the objective psyche, and for Tindel this involves accepting his shadow qualities, which are the

---

<sup>1</sup> Campbell, J., Primitive Mythology, (New York, 1959): p388

<sup>2</sup> Colli, G., The Birth of Philosophy, (Milan, 1975): p29

numinous qualities of the animal god.<sup>X</sup> Within the labyrinth in Sleuth these shadow qualities are first symbolised by the archaic stone statues of gorillas and ogres which act as references to the ancient dark-side of man, and by the mirrors which symbolically show that Tindel is going to experience a new image of himself, which is the as yet unrealised shadow of his psyche. As Chetwynd has commented,

'The ego confronts its own Shadow as a figure thrown upon the wall or reflected in the glass, projected into the outside world. Symbolism does not distinguish clearly between reflections and shadows - children sometimes share the confusion on this point'.<sup>1</sup>

In Sleuth it gradually becomes clear that Tindel is assimilating his shadow qualities, indeed it is almost as though they have begun to possess him. This is evident when he returns disguised as Inspector Dopler (almost the German for double) and proceeds to play at Wyke's expense a new shadow-game. Tindel is able to control his shadow and has no desire to kill Wyke and only wishes to extract his revenge, but Wyke is not equally in control and becomes boastful about his psychological gamesmanship.

'Let me tell you Inspector that I have played games of such complexity that Jung and Einstein would have been proud to have been asked to participate in them. I have achieved flights of the mind and flights of the psyche.'

#### Sleuth

However Wyke's shadow possesses him and he passes into the psychological area of affect and invasion. Perhaps the reason for this is that he has not yet realised that the games of the psyche are not illusory but real, just as individuation is a 'real' process. In the same way Tindel had to recognise that the distorted image of himself in the mirrors of the maze was not an illusion but an image of a part of his psyche, of his shadow. However ultimately Wyke is overwhelmed by his shadow. Much as the Cretan

---

<sup>1</sup> Chetwynd, T., A Dictionary of Symbols, (London, 1982): p261

labyrinth claimed Icarus, its creator's son, so too this labyrinth claims as its victim the gamemaster's apprentice.

To conclude, from the above analysis it can be seen that the symbol of the labyrinth prefigures much of the film's later imagery. It does this in three ways: first it prepares the viewer for a complex and 'deceptive' narrative, secondly it mythologically indicates a descent into the underworld and thirdly it psychologically symbolises the onset of one stage in the individuation process.

The second film that will be examined, Woman in the Window, (Dir. F. Lang, RKO, 1944) is in many ways different from Sleuth. This Film Noir which is stereotypically set amid wet night time city streets seems very distant to the English Country House which provided the setting for Sleuth. But underneath this apparent diversity the two films share much in common and when it is remembered that they share the same mythologem, namely the quest motif, and that they are both broadly detective films then these underlying affinities seem less surprising.

Woman in the Window starts with Richard Wanley, (Edward G. Robinson) a professor of criminology, giving a lecture on the ethics of crime. On leaving the lecture and going to his club he notices in a window a painting of a beautiful woman. He arrives at his club and discusses the picture with his friends who eventually leave and Wanley falls asleep while reading the Song of Songs. On waking he goes outside for a last look at the picture and to his surprise the real woman, Alice, (Joan Bennett), appears. From here on Wanley is drawn deeper and deeper into the underworld. First Alice persuades him to help her murder her husband. Wanley does this but gradually becomes involved with the official police investigation, and ends

up helping them to solve the crime that he has committed. At the same time he and Alice are being exploited by a blackmailer, (Dan Duryea). Wanley plans a second murder, which fails, and Alice poisons herself. At this point Wanley wakes up to discover that the whole episode has been an unpleasant dream.<sup>XI</sup>

As in Sleuth the passage that will be analysed occurs near the beginning of the film, and it is the section in which Wanley falls asleep and the dream sequence is started. The indication to the film's viewer that a dream sequence has started is a dissolve between Wanley reading the Song of Songs to him being woken up by a steward of the club. There is also his comment to the steward, 'Will you remind me when it's ten thirty? Sometimes I'm inclined to lose track of time'. As the verbal clues to the dream sequence are so subtle and as this type of dissolve is a normal cinematic device to indicate the passing of time, it would seem that Lang intends to keep the viewer, along with Wanley, ignorant that the film is an extended dream sequence. The consequence of this is that it increases identification with the criminal, and this difficult situation is resolved by making the film a dream and therefore 'unreal'. As the dream sequence starts, Wanley leaves his club and goes to examine the portrait in the window. Here his face is shown beside a reflection of the painting and there follows a shot which is just a close-up of the painting and this is joined by the reflection of the real Alice. Thus the portrait and reflection of its subject are combined, in a highly cinematic way, into one composite image.

In interpreting the above passage symbolically it helps to remember that this is supposed to be a dream, and in a way this takes the film even further away from any 'reality'. Not only is the film a fiction but it is a



fiction which represents a dream, which is to say that it is at two removes from reality. In the terms of analytical psychology it would be reasonable to suggest that Alice is a projection of Wanley's anima. She possesses many typical anima attributes which include being attractive, highly sexual, her night time appearances, and living in the underworld.<sup>XII</sup> In many ways she is the typical femme fatale figure who lures an innocent and weak man to his eventual destruction, and in this case she persuades Wanley to commit a murder.

Developing the idea that Alice is a projection of Wanley's anima it is interesting to note that Hillman has observed that the figures we meet in dreams are aspects of our own psyche.

'What walks through my dreams is not actual other persons or even their soul traits mirrored in me (ikons or simulacra of them), but the deep, subjective psyche in its personified guises'.<sup>1</sup>

Therefore what this sequence psychologically deals with, as does the rest of the film, is the union of opposites the CONIUNCTIO of anima and ego. This idea is mythologically hinted at in Wanley's selection of the Song of Songs as his reading. Here the lonely professor reaches for the most erotic and sensual book in the Bible. It is as though he knows he must delve into his female numinous qualities, and so delve into his objective psyche. Only after selecting this book does he fall asleep. It is almost as though he is giving himself permission to dream, that is permission to enter into a fantasy world which is the property of the objective psyche.<sup>XIII</sup> This is reminiscent of a passage in the Song of Songs in which the bridegroom falls asleep to awaken his heart.

---

<sup>1</sup> Hillman, J., The Dreams of the Underworld, (New York, 1979): p98

'I slept but my heard was awake.  
 Listen! My lover is knocking:  
 Open to me, my sister, my darling,  
 my dove, my flawless one'.<sup>1</sup>

However the process of anima assimilation is difficult because it involves entering the darkness of the underworld so that the darkness, and its contents, can be assimilated into ego-consciousness. Just as Milo entered the labyrinth in Sleuth so Wanley enters the darkness of a nightmarish dream to face the femme fatale, which is to face his anima. As Jung notes,

'Filling the conscious mind with ideal conception is a characteristic of Western Theosophy, but not the confrontation with the shadow and the world of darkness. One does not become enlightened by imagining figures of light, but by making the darkness conscious'.<sup>2</sup>

The pain and difficulty of this encounter is also present in the Song of Songs. As Edinger notes,

'The encounter in the garden includes pain as well as pleasure. The Bridegroom is wounded:

"You ravish my heart,  
 My Sister, my promised bride,  
 You ravish my heart  
 with a single of your glances".

... One aspect of the coniunctio is that opposites are seen by each other... which has a wounding or violating effect'.<sup>3</sup>

The wounding of Wanley is that he is driven to commit a murder, while Alice's wound is her death. But of course the whole episode, initiated when Wanley falls asleep is a dream and therefore unreal. Much as the games played in Sleuth were an illusion so too the fatal attractions of Alice prove to be illusory because after all they were only a dream. However the dream is an important part of the objective psyche's life, it is

---

<sup>1</sup> The Bible, Song of Songs, New International Version, (London, 1978), 5:2

<sup>2</sup> C. W. 13: 335

<sup>3</sup> Edinger, E. F., The Bible and the Psyche, (Toronto, 1986): p141-142

an active participant in the work of soul making which Jung called individuation. As he noted what may be an illusion or dream for us may be very real to the psyche.

'But what is "illusion"? By what criterion do we judge something to be an illusion? Does anything exist for the psyche that we are entitled to call illusion? What we are pleased to call illusion may be for the psyche an extremely important life-factor... Nothing is more probable than that what we call illusion is very real for the psyche...' <sup>1</sup>

According to Hollywood logic the dream in Woman in the Window made the murder unreal, but from the psychological viewpoint the opposite is true. As Tyler notes, 'But the fact is that in making the professor's crime occur in his dream its psychological reality, its mental precipitation, this alone, is established'. <sup>2</sup>

This analysis of the opening moments of the dream sequence has shown that the symbols which occur during this moment, and their associated mythological and psychological themes, prepare the way for the later narrative transformations. In part this is the function of all opening sequences, but what is significant about this sequence is that it is the symbols and myths which almost foretell the psychological destiny of Wanley. In other words throughout the film there is a process of symbolic transformation which equates with the development of the narrative. As in Sleuth the symbols contain, and express, the oppositional themes of the film, for example; illusion/reality, male/female. The concatenation of these elements combined with their gradual assimilation into ego-consciousness (coniunctio) is seen as an integral part of Wanley's individuation.

---

<sup>1</sup> C. W. 16: 111

<sup>2</sup> Tyler, P., Magic and Myth of the Movies, (London, 1971): p167

CONCLUSION

The analysis of the symbolic passages in Sleuth and Woman in the Window has shown that the symbols give expression to apparent oppositions within the narrative. The symbols are also, integrally linked to the individuation processes of the films' central characters, and as such they indicate the psychological development of the characters. Now that the theory and application of the symbol has been demonstrated, it is appropriate to progress to the remaining area of the analytical model, and to explore its theoretical basis and application. This area, which is of central importance to analytical psychology, is the individuation process.

CHAPTER SIX NOTES

- I. c.f. Capra, F., The Turning Point, (London, 1982). This edition, (London, 1987). *passim*.
- II. For a full account, c.f. Collected Works, Vol. 11: 296-448. (Transformation Symbolism in the Mass).
- III. For an accessible and detailed example of this type of analysis, c.f. Branson, C., Howard Hawkes, a Jungian Study, (Los Angeles, 1987). Also c.f., Introduction.
- IV. The assumption which underlies analytical psychology is that the objective psyche gives direction to psychological growth. One of the ways which it achieves this is by liberating images, through dreams and other creative activities, which are in opposition to ego-consciousness. Thus someone with a mother complex might find their objective psyche liberating images of the father, or perhaps more subtly, the anima. As these images are the opposite of what ego-consciousness expects they are said to exist in a compensatory attitude, or opposition, to ego-consciousness.
- V. A specific symbol of wholeness identified by Jung is the mandala. This is an image of balance and represents the integration of the conscious and unconscious aspects of the psyche, c.f. C. W. 12: 122-331, The Symbolism of the Mandala.
- VI. For another labyrinth that also leads to the underworld, and from a separate culture, c.f. Beckwith, M. W., Hawaiin Mythology, (Yale, 1940): p157
- VII. c.f. Campbell, J., Primitive Mythology, (New York, 1959). This edition, (London, 1984): p197
- VIII. There are numerous myths which regard the snake as a symbol of life, c.f. Campbell, J., Primitive Mythology, (London, 1984): p388. There is also the interesting Hindu myth in which the giant snake Vasuki is used to turn a mountain to churn up the ocean and produce soma, which is the elixir of immortality. However as might be expected in symbolism, it also produces a deadly poison.
- IX. The image of the labyrinth as a symbol of individuation is explored in detail below, c.f. Chapter Eleven, Archetypal Pattern and Mythology, p305-312
- X. There is an interesting literary parallel to this in Hermann Hesse's novel, Steppenwolf. In this novel Harry Haller believes himself to possess a personality which is half man and half wolf. In the search for enlightenment (individuation - here the integration of his shadow) he enters a magic theatre for which the entrance fee is his sanity and also the life of his love Hermanie whom he kills. This magic theatre is very like a magic labyrinth, and the theatre's many pathways and doors conceal projections of Haller's character, some of these are beautiful while others are ugly and painful. Unfortunately for Haller he never succeeds in dissolving these projections and integrating their contents into ego-consciousness. Consequently he appears not to progress with his individuation, as he notes at the end

of the novel, 'I would traverse not once more, but often, the hell<sup>1</sup> of my inner being. One day I would be a better hand at the game'. The title sequence of Sleuth is a series of miniature 'magic' theatres each containing a reconstructed scene from one of Wyke's fictional murder stories. And like Haller in Steppenwolf, Tindel enters into the fictional world of drama and illusion to discover some previously hidden aspect of himself.

- XI. The elements of Woman in the Window are very similar to a film that Lang was to direct a year later (Scarlet Street, Diana Productions-Universal, 1945). Both are set in the darkness of the city and make use of the classic city streets, hideous rooms full of bizarre objects and typically the lighting is low key high contrast. In both films Edward G. Robinson plays a sexually frustrated lonely man who becomes the victim of a femme fatale played by Joan Bennett. This preoccupation of Lang's is interesting and it indicates either some outworking of his own psychology or more likely, it is an expression of a collective psychological need. (c.f. C. W. 10: 195). The evidence for this is the large number of other films which have broadly similar plot themes and situations. For example, Laura, (Dir. O. Preminger, Twentieth Century Fox, 1944) and Double Indemnity, (Dir. B. Wilder, Paramount, 1944). Parker Tyler also notes that this upsurge in films of this type reflects '... the inevitable albeit sub-conscious interest aroused in the public by the conception of war as murder and, following this line of thought, the conception of murder as psychological...'<sup>2</sup>
- XII. This is a filmic example of the anima qualities established in Chapter Two, p64-65. The idea of the femme fatale as a projection of the detective's anima is developed in the next chapter, Individuation and the Detective, p206-211.
- XIII. Again the magic theatre of Steppenwolf is called to mind.

---

<sup>1</sup> Hesse, H., Steppenwolf, (Germany, 1927). This edition, (London, 1986). Translated, Creighton, B.: p253

<sup>2</sup> Tyler, P., Magic and Myth of the Movies, (London, 1971): p166

Chapter Seven

Individuation and the Detective

INTRODUCTION

Individuation and the Detective represents the final chapter of Part Two of this thesis and is also the last of the purely theoretical chapters. It develops the theoretical basis of Section One, and provides a specific examination of the individuation process as by utilising the model established earlier in Part Two. This chapter also seeks to find further points of contact between the theory of analytical psychology and filmic material. Specifically examined is the process of individuation as it relates to the hero-detective.

This chapter consists principally of two sections. First there is a general, and brief, introduction to the individuation process. This is a development of the concept as introduced in Chapter Two. Secondly there is a detailed exploration of individuation in which the process is divided into a total of eight key phases. Each phase is examined and, if relevant, its relationship to the detective film is developed. This is especially true for the sections on shadow, anima and mana personality.



WHAT IS THE INDIVIDUATION PROCESSAn Overview

In many ways the individuation process can be thought of as the theoretical construct which unites the apparently disparate elements of analytical psychology. For Jung individuation is no more than a natural biological process which is inherent in all mankind; in fact it means only that each individual achieves his or her full human potential. The chemical controls for the individuation process lie dormant in the molecular base of human biology, and throughout the course of a life time the archetypal sage gradually unfolds.<sup>I</sup> As Humphrey has noted,

'I cannot hope to summarise here the extensive research through which Jung claimed to have established the existence of particular archetypes. But, assuming the phenomenon to be genuine, I would propose a biological function for archetypal dreams: they will give the dreamer advance knowledge of certain universally significant human experiences, experiences of which he as a natural psychologist cannot afford to remain ignorant'.<sup>1</sup>

The chemical base, of biological controls which regulates the archetypal individuation process is in the deoxyribonucleic acid (D.N.A.). So in a biological sense archetypes may be reducible to their biochemical origins; however, in psychological terms they remain 'living', dynamic and organising structures.<sup>II</sup>

Most Jungians regard the individuation process as something which is confined to the latter half of human life, that is after thirty five, and they claim that only then are the archetypal patterns constellated and the contents of the unconscious and objective psyche released. However later Post-Jungian thought regards the first half of life, which is characterised by the awareness of ego identity, as an integral part of individuation.

---

<sup>1</sup> Humphrey, N., Consciousness Regained: chapters in the development of the mind, (Oxford, 1983): p91

'The first half (of life) is characterized by the need for a differentiation from the unconscious matrix, the indistinct uroboros from which the individual psyche gradually emerges. What encourages the formation of a conscious centre of the personality, the ego, is called by Neumann the tendency towards centroversion, the "innate tendency of a whole to create unity within its parts and to synthesize their difference in unified systems".' <sup>1</sup>

As mentioned, some theoreticians regard the centroversion stage as a precursor to individuation. However, it seems more satisfactory to regard individuation as a total life process which spans from birth, or possibly conception, to death. During the second half of life the process of centroversion continues, so that the ego comes to take an active role in the synthesising of opposites and in the differentiation of the conscious and unconscious parts of the psyche. As Carotenuto observes,

'The task of the second half of life is the harmonization at a higher level of the various parts of the personality; it is the conscious realization of the tendency towards centroversion of which the ego is no longer the passive object but the conscious protagonist. The extreme differentiation of consciousness, with the deep split that it creates within man, is also the means for beginning that search for totality which according to Jung characterizes the process of individuation'.<sup>2</sup>

The individuation process is concerned with overcoming the 'deep split' between conscious and unconscious elements in the psyche, that is caused by the act of differentiation. In fact individuation is concerned with the reconciliation of all opposites and opposition within the psyche, its ultimate aim being to stabilise the psyche as a complete whole, that is as an integrated person. An example of this reconciliation of opposites is the way in which the contrasexual archetype of anima, or animus, is integrated and reconciled with physical conscious sexuality.

---

<sup>1</sup> Carotenuto, A., The Vertical Labyrinth, (Canada, 1985): p119

<sup>2</sup> Carotenuto: p120

As can be imagined the path that the individuation process maps out for humanity is not an easy one. Hence in the symbolic language of the unconscious it often assumes the image of a winding road, a labyrinth or a quest. As already demonstrated<sup>III</sup> the detective's search for truth, which is in essence a quest myth, is also a metaphor of the individuation process. As Jung notes,

'But the right way to wholeness is made up, unfortunately, of fateful detours and wrong turnings. It is a longissima via, not straight but snakelike, a path that unites the opposites in the manner of the guiding caduceus, a path whose labyrinthine twists and turns are not lacking in terrors'.<sup>1</sup>

While the individuation process is about becoming whole, it is not about becoming perfect, because the process is concerned with the integration of opposites into the whole, and not the removal of opposition. For example it is concerned with the acceptance of the shadow, not with an attempt to repress it, nor in some act of attempted psychological surgery to amputate this seemingly troublesome part of the psyche. Individuation is about realising the fullness of human potential, and this includes an acceptance of humanity's darker side. As Hillman has commented,

'The process of individuation or the work of soul-making is the long therapeutic labour of lifting repression from the inhumane aspects of human nature... Self-realization involves the realizing in consciousness of the psychopathic potential one prefers to call inhumane'.<sup>2</sup>

The term individuation may also be slightly misleading because while individuation is about the realisation and development of an individual's own unique potential it also involves the acceptance of collective ties. The archetypes which govern our life are, by their biological nature, collective and it is important to accept this collectivity, because contrary to

---

<sup>1</sup> C. W. 12: 6

<sup>2</sup> Hillman, J., Re-Visioning Psychology, (USA, 1975): p188

what might be expected, acceptance does not remove individuality but increases it.

'... we do not sufficiently distinguish between individualism and individuation. Individualism means deliberately stressing and giving prominence to some supposed peculiarity, rather than to collective considerations and obligations. But individuation means precisely the better and more complete fulfillment of the collective qualities of the human being, since adequate consideration of the peculiarity of the individual is more conducive to better social achievement than when the peculiarity is neglected or suppressed'.<sup>1</sup>

To recap, for Jung the process of individuation is primarily about awareness or realisation of the latent unconscious elements in the human psyche, and this involves the acceptance of contradiction, opposition and of individual's psychological complexes. In this action of self-realisation, an individual's level of conscious awareness is raised as he or she becomes aware of previously concealed elements in their psyches. This increase in conscious awareness does not resolve the problems or oppositions in the psyche, but rather it transcends them. As consciousness is increased so more complexes are transcended and both individual and collective qualities can be realised. As Jung comments,

'Self-reflection or - what comes to the same thing - the urge to individuation gathers together what is scattered and multifarious, and exalts it to the original form of the One, the Primordial Man. In this way our existence as separate beings, our former ego nature, is abolished, the circle of consciousness is widened, and because paradoxes have been made conscious the sources of conflict are dried up'.<sup>2</sup>

However it would be a mistake to think of the individuation process as a panacea. As Jung has commented above, and as shall be further demonstrated later in the chapter, individuation is a treacherous and lengthy quest.

---

<sup>1</sup> C. W. 7: 267

<sup>2</sup> C. W. 11: 401

As a quest it is concerned with identifying problems, or, to be more technical, complexes, and in their conscious realisation, not their removal. The result of this is that the psyche can more readily comprehend and work with a given complex. Individuation should not be thought of as an easy option, but as a life process in whose participation there is no choice. Being human means experiencing and living the difficulties of individuation.

'The serious problems of life, however, are never fully solved. If ever they should appear to be so it is a sure sign that something has been lost. The meaning and purpose of a problem seem to lie not in its solution but in our working at it incessantly. This alone preserves us from stultification and petrification'.<sup>1</sup>

While individuation can be conceived as the process to which all the elements of analytical psychology are devoted, it would be incorrect to regard individuation as somehow superior or separate from the archetypes. It is in fact the archetypes which govern or control the process, and as Hillman comments below, Jungians in their emphasis on visual and mytho-symbolic material tend to literalise processes. In reality individuation is not a literal process it is the fulfilment of archetypal intent, and as such individuation provides one useful and theoretical way of examining the workings of the psyche. For most Jungians and Post-Jungians it is the principal method and this explains why the model in Chapter Four has individuation as its central process. However the model has been carefully constructed so that the primacy of archetypal intent is preserved and the symbols, myths, and individuation are regarded as expressions of this primary purpose. To return to Hillman, he comments:

---

<sup>1</sup> C. W. 8: 771

'Where existentialists neglect process, Jungians literalize it. Because the process of individuation is an archetypal fantasy, it is of course ubiquitous and can be "demonstrated" in texts and cases, just as any archetypal fantasy has its manifestation in historical events. But this process is not the axiomatic law of the psyche, the one purpose of ensouled beings... Individuation is a perspective. It is an ideational tool: we do not see individuation, but by means of it'.<sup>1</sup>

#### OVERTURE TO A DETAILED EXAMINATION OF THE INDIVIDUATION PROCESS

For general purposes the individuation process can be divided into four sections and these are: formative, dispositive, perfective, and differentiative. The formative phase represents the progress of ego-centroversion in which the ego is established and separated from the general matrix of the unconscious. As such it is an important phase in individuation, but for this chapter's method the remaining three phases are of more importance because they deal with the development of the ego. The dispositive phase consists of disposing of the persona, which is the psychological protection we have to both the outer world and the inner world of primordial images. The perfective phase is concerned with the making conscious of the unconscious clusters of archetypal patterns, and this involves recognition of their existence and their compensatory nature. The final differentiation phase consists of differentiating between conscious and unconscious parts of the psyche. This stage is not as simple as it may appear because an apparently conscious event, for example the intense dislike of someone or something, may in fact prove no more than the projection of an inner unconscious complex. The process of differentiation is vital, for without an awareness of the critical distinction between the conscious and unconscious the synthesis of these opposites, which occurs later in individuation, cannot be achieved.

---

<sup>1</sup> Hillman, (1975): p147

Differentiation is principally a cognitive process, although it is not exclusively rational, for throughout this phase there exists a dialogue between the ego and the unconscious, and whenever the unconscious is present then symbols, myths and dreams etcetera will also occur. As has already been argued, these unconscious communications are not totally available to a rational analysis as they represent trans-rational truths, or more accurately truth not yet grasped by the conscious part of the psyche. The Jungian Moreno has commented on this phase and emphasises the importance of understanding, and active participation, during differentiation.

'First we must understand the meaning of the fantasies produced, then we must experience them to the full, which demands not only perception, discussion, and passivity, but above all active participation'.<sup>1</sup>

The process of analysis, as demonstrated by this thesis, is therefore equivalent to Moreno's stage of understanding the fantasies. As already mentioned the very act of understanding, or making conscious, these fantasies helps the cultures or individuals concerned to transcend the oppositions contained within the collective objective psyche, and this explains Jung's term for the increase in consciousness - the 'Transcendent Function'.

Throughout differentiation, as consciousness is increased, so the centre of the personality moves from the outer ego to the inner psyche, and the constellation of this new archetype of the Self represents the final phase in individuation. This is another way of saying that throughout individuation the ectopsychic system becomes aware of and assimilates the inner endopsychic system. While individuation may assume many forms, as individuals and communities each experience it within their own unique environment, there is one pattern which recurs repeatedly and it seems to represent

---

<sup>1</sup> Moreno, A., Jung, Gods and Modern Man, (USA, 1970): p37

the norm, on both cultural and personal scales. This typical developmental pattern is illustrated below.

Schematic Diagram of the Individuation Process

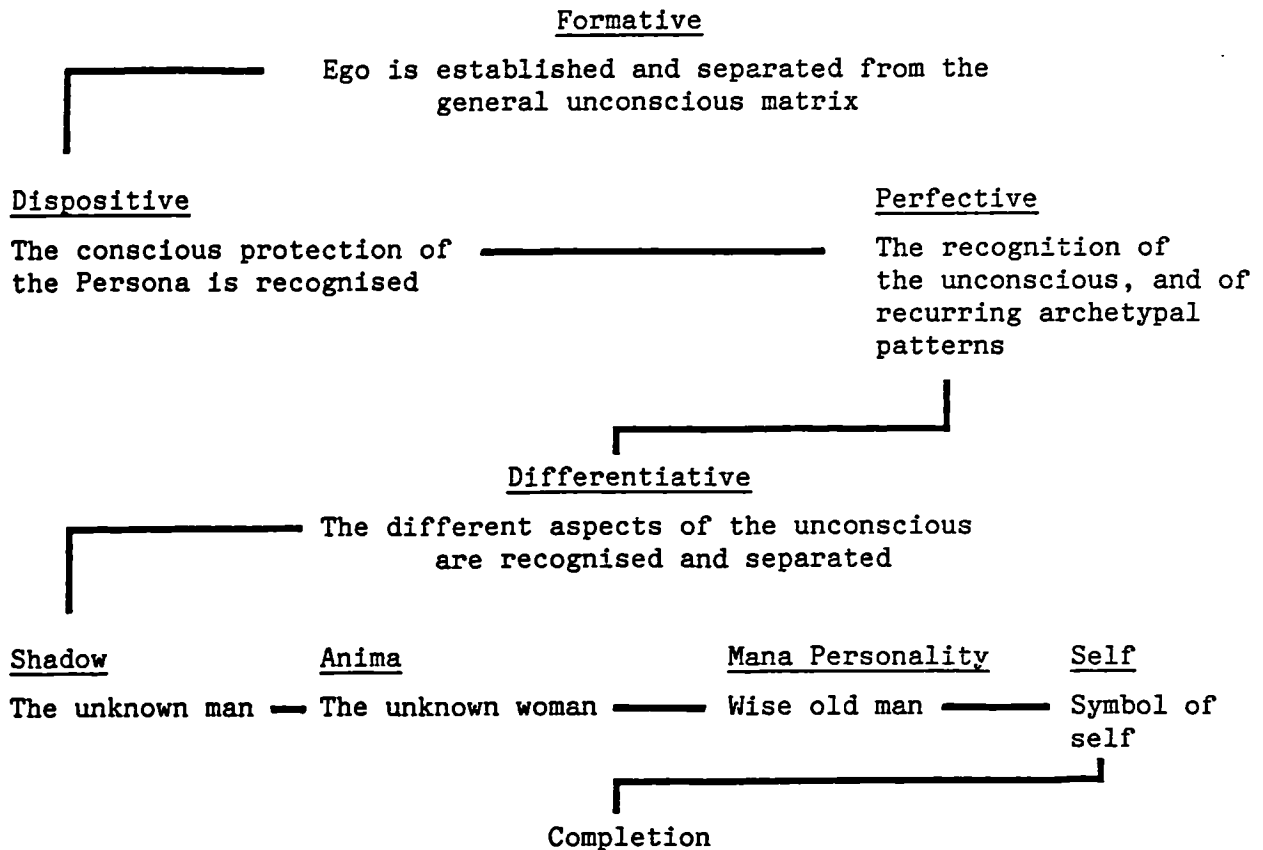

A DETAILED EXAMINATION OF THE INDIVIDUATION PROCESS

The Dispositive Phase

The first stage in the dispositive phase is recognition that every individual and indeed culture possesses a persona. The term persona refers to the mask, or personality that is worn to confront the world with.<sup>IV</sup> Jung regards the persona as an archetype, and when an individual recognises it as such, the mask is removed to reveal the true nature of the unconscious, however dark and seemingly unpleasant this may be. Thus once the persona has been consciously identified it can be disposed of, or rather, as there



is no longer any need for it, it is transcended. As Jung notes,

'... whoever looks into the mirror of the water will see first of all his own face. Whoever goes to himself risks a confrontation with himself. The mirror does not flatter, it faithfully shows whatever looks into it; namely, the face we never show to the world because we cover it with the persona, the mask of the actor. But the mirror lies behind the mask and shows the true face'.<sup>1</sup>

As the psyche is regulated by the principle of opposition, the persona should be seen as in opposition to something and, according to Jung, during the dispositive phase there is an anticipation of the later anima differentiation. Once the persona is recognised, then the mask is removed to reveal the outer layers of the unconscious, first the shadow appears and at the same moment the anima is projected onto the outer world. Thus it is vital to pass through the perfective phase and to recognise this anima projection, for without this the shadow cannot be identified nor the anima integrated. As Jung has commented,

'The persona, the ideal picture of a man as he should be,<sup>v</sup> is inwardly compensated by feminine weakness, and as the individual outwardly plays the strong man, so he becomes inwardly a woman, i.e., the anima, for it is the anima that reacts to the persona. But because the inner world is dark and invisible to the extraverted consciousness, and because a man is all the less capable of conceiving his weaknesses, the more he is identified with the persona, the persona's counterpart, the anima, remains completely in the dark and is at once projected, so that our hero comes under the heel of his wife's slipper'.<sup>2</sup>

#### Differentiation - The Shadow

In the previous quote Jung remarked that the 'inner world is dark and invisible to extraverted consciousness'. The result of this is that if anyone is to look into the inner world, then ego-consciousness must shift its emphasis from extraversion to introversion. As already mentioned, the

---

<sup>1</sup>C. W. 9, I: 43

<sup>2</sup>C. W. 7: 309

unconscious can only be understood or comprehended in the language of consciousness, so the result of the inner journey is an increase in conscious awareness. In other words the 'vocabulary' of consciousness is expanded to include the findings of this introspective quest.

The first archetype that is encountered after the persona on this inward journey is the archetype of the shadow,<sup>VI</sup> and many Jungian theoreticians regard the recognition of the shadow as the first true step in individuation. It will be recalled that the shadow may be defined as the negative side of being human, the aspect of humanity which ego-consciousness has pushed into darkness. However, as might be expected from the psychological principle of opposition, the shadow may have good qualities, and it also contains parts of the personality which, due to personal circumstances, have never been developed.

'If the repressed tendencies, the shadow as I call them, were obviously evil, there would be no problem whatever. But the shadow is merely somewhat inferior, primitive, unadapted, and awkward; not wholly bad. It even contains childish or primitive qualities which would in a way vitalize and embellish human existence, but it is not done.

The shadow principally belongs to the personal unconscious, that is to the part of the psyche which has been conditioned through personal environmental circumstances. However it is an archetype and as such it possesses a collective and numinous quality. Of course numinosity is by no means a universally good quality and when the shadow, after a period of cultural repression, breaks out then the numinosity which archetypes carry with them contributes to the 'evil' of the now rampant archetype. During a period of repression the shadow builds in strength until the dam of consciousness can no longer contain it, and it breaks forth in an uncontrollable surge.

---

<sup>1</sup> C. W. 11: 134

Examples of the shadow occurring on such a dramatic cultural scale must include the Nazi's Jewish persecution, the medieval witch hunts and the Ku Klux Klan's persecution of non-whites.<sup>VII</sup> To once more cite Jung,

'... it is a frightening thought that man also has a shadow-side to him, consisting not just of little weaknesses and foibles, but of a positively demonic dynamism. The individual seldom knows anything of this; to him, as an individual, it is incredible that he should ever in any circumstances transcend himself. But let these harmless creatures form a mass, and there emerges a raging monster; and each individual is only one tiny cell in the monster's body, so that for better or worse he must accompany it on its bloody rampages and even assist it to the utmost'.<sup>1</sup>

If the archetypes are left latent or repressed in the psyche then the damage caused by not integrating the archetypes is formidable. It might be thought that not accepting the shadow is something which is contained or limited to an individual's psyche. However this is not the case for there is a tendency for these autonomous elements, the archetypes, to become personified. This personified image may be contained within an individual's psyche or it may be projected onto the outer world, which inevitably affects his or her relationship to this outer world. As Moreno comments, 'The unconscious does the projection and the projection changes the world into a replica of one's own unknown face, which isolates the subject from his environment'.<sup>2</sup>

#### THE DETECTIVE AND HIS SHADOW

As has already been shown the criminal can be regarded as a personified projection of the hero-detective's shadow. In fact the criminal can represent almost any aspect of the detective's psyche.<sup>VIII</sup> Once this dialogue between criminal and detective, or shadow and ego-consciousness, is recognised, it should not be surprising to find the detective is closely asso-

---

<sup>1</sup> C. W. 7: 35

<sup>2</sup> Moreno, (1970): p41

ciated with Film Noir. Further the high contrast, and hence deep shadow lighting which characterises Film Noir is particularly suitable for a symbolic portrayal of this relationship. In fact later detective films have emulated this lighting technique not only as a generic convention but with an intuitive awareness of the shadow's importance. Perhaps the two most notable films of this style are Hammett, (Dir. W. Wenders, Warner Brothers, 1982) and Farewell My Lovely, (Dir. D. Richards, Fox, Rank, 1975).

As the previous quote noted it is the projection of the shadow which isolates the subject from his or her environment, and for the detective this means that he is isolated from the underworld in which crime occurs. In the detective film the detective's isolation from the environment is normally achieved in one of two ways. First the narrative may centre around a location in which he is a stranger, for example Chinatown. Alternatively it may be just a crime-ridden city where any force for good is alien, and hence separate from the criminal underworld. The second way this alienation can be achieved is to give the detective a physical or psychological handicap. For example he could be physically confined to a wheelchair or psychologically 'crippled' suffering from forgetfulness or over-intellectualisation. In later developments of detective mythology, the detective often belongs to a police force, which, as part of the state apparatus, removes him from the anarchic world of crime. Although even here he is often portrayed as a maverick cop who is in a state of tension with the official structures of law enforcement, (e.g. Dirty Harry, Dir. D. Siegel, Warner Brothers, 1971). So while the detective is physically set apart from the world of crime he is psychologically part of that world, for in actuality the underworld is little more than a shadow-toned projection of his own unconscious. Thus there exists a dynamic tension between the projected world of crime and the detective's own ego/shadow dialogue.

This tension, and indeed all the factors cited above, can be viewed as integral parts of the individuation process. For example the detective in pursuing the criminal is actually chasing his own shadow. Also the crimes that he is trying to solve operate as metaphors for his own psychological complexes, and like the archetypes these have been projected onto the underworld. However the cultural and sociological dimension to this projected mythology should not be ignored. The hero-detective actually stands as a representation of collective ego-consciousness, although he is imbued with further archetypal qualities. Likewise the criminal represents not only the hero's shadow but also a collective darkness which we, like the detective, quite literally project.

During the differentiation phase of individuation the detective must first recognise that the criminal is a projection of his own unconscious shadow qualities. So too, culturally, the world of crime, and the criminal need to be recognised as projections of our cultural unconscious and cultural shadow. The desire not to recognise these projections is termed by Jung 'Resistance', and it is an attempt to stop the natural functioning of the archetypes and as such is a complex. However the difficulty is that complexes are not easy to recognise,

'... the cause of emotion seems to lie, beyond all possibility of doubt, in the other person. No matter how obvious it may be to the natural observer that it is a matter of projections, there is little hope that the subject will perceive this himself. He must be convinced that he throws a very long shadow before he is willing to withdraw his emotionally-toned projections from their object'.<sup>1</sup>

Once the shadow has been identified then the question of how this part of the personality can be coped with is raised. There are three possible

---

<sup>1</sup> C. W. 9, II: 16

solutions to this problem: repression, suppression and assimilation.

Given the mostly unpleasant nature of the shadow,<sup>IX</sup> it may prove tempting to opt for either repression or suppression, and the difference between these two options is defined by Jung as follows:

'Repression is a sort of half-conscious and half-hearted letting go of things, ... a looking the other way in order not to become conscious of one's desires... Suppression amounts to a conscious moral choice .. (it) may cause worry, conflict and suffering, but it never causes a neurosis. Neurosis is always a substitute for legitimate suffering'.<sup>1</sup>

It has already been mentioned how dangerous it can be to repress the shadow, as while it is being repressed it grows in strength like a malignant tumour and starting from a single cell it grows to infect the whole body. The same is true of suppression, this too causes an intensification of the shadow side and prevents further progress with individuation. The result is like throwing away a whole cart of fruit because one apple has gone rotten.

The question seems to be not how can the shadow side be disposed of, but rather, how can we exist with the dark side without becoming dark ourselves? As opposition is both a regulating law and source of energy for the psyche, so shadow and ego, light and dark have to co-exist in, what is admittedly, a precarious unity. Thus the shadow should not be repressed but recognised and accepted as part of the psyche. If the individuation process is conceived of as a labyrinth-like series of paths which gradually lead deeper and deeper into a mountain, then the recognition (differentiation) of the shadow and its acceptance (assimilation) takes us one stage further on the mysterious quest of individuation. One stage closer to the centre of the maze wherein lies the final secret of individuation. As Jung notes,

---

<sup>1</sup> C. W. 11: 129

'The shadow is a tight passage, a narrow door, whose painful constriction no one is spared who goes down to the deep well. But one must learn to know oneself in order to know who one is. For what comes after the door is, surprisingly enough, a boundless expanse full of unprecedented uncertainty, with apparently no inside and no outside, no above and no below, ... It is the world of water, where all life floats in suspension; where the realm of the sympathetic system, the soul of everything living, begins; where I am indivisibly this and that; where I experience the other in myself and the other-than-myself experiences me'.<sup>1</sup>

In accord with Stein's method of classification of archetypes, the shadow is not conceived of as a discrete archetype but as an aggregate. Here the persona or outer man, prefigures the inner man of the shadow, and the persona and the shadow alike herald the arrival of the anima or inner woman who is the archetype of the spirit. As those on the quest meander deeper into the labyrinth so the archetypes encountered, or constellated, become more powerful and numinous. In each stage the archetype is differentiated into, and by, ego-consciousness, every archetype assimilating and transcending the previous one until finally a total synthesis is achieved, the archetype of the Self is established and the individuation process is completed.

### Summary

- 1) The archetype of the shadow contains both positive and negative qualities; it is also the property of both the personal and collective unconscious.
- 2) There is a tendency for the shadow to become projected and personified - in the case of the detective the shadow is personified in the figure of the criminal.
- 3) Rather than repressing or suppressing the shadow it must be assimilated into the functioning of ego-consciousness.

---

<sup>1</sup> C. W. 9, I: 45

DIFFERENTIATION - THE CONTRASEXUAL ARCHETYPE

On the inner journey of individuation the next archetype to be encountered and assimilated into the psyche is the contrasexual archetype; that is anima or animus. In the case of the anima this archetype forms the female part of man's psyche, as once again in accord with the psychological principle of opposition, man carries within himself the image of the unknown woman. (Of course the reverse is true for women who carry with them an unknown masculine aspect. However as this chapter deals principally with the psychology of the masculine detective this discussion will centre around the figure of the anima which the detective carries as a part of his psyche.

While the anima is female she does not represent the totality of feminine influences on man. For example both mothers and wives exert a strong influence on men, but they are not the anima, although they may have anima qualities projected onto them. Rather Jung defines the anima as an archetype, an imprinted pattern of the human ancestral experience of the female.<sup>X</sup>

'Every man carries within him the eternal image of woman, not the image of this or that particular woman, but a definite feminine image. This image is fundamentally unconscious, an hereditary factor of primordial origin engraved in the living organic system of the man, an imprint or "archetype" of all the ancestral experiences of the female... an inherited system of psychic adaptation... The same is true of the woman: she too has her inborn image of man'.<sup>1</sup>

Thus the anima and the animus not only show themselves projected onto the personal world but also reveal themselves on a universal scale. To have any understanding of the anima it is important to know of its universal significance in mythology, comparative religion, literature, film, and

---

<sup>1</sup> C. W. 17: 338



wherever an anima manifestation can be recognised. What follows is a very brief table indicating some of the images that the anima and animus may assume. Like the shadow, the contrasexual archetype possesses both positive and negative qualities; and as archetypes they dwell in a realm which is numinous, magical and dangerous. The anima especially possess the secret knowledge of hidden wisdom (Sophos) which the detective needs if his quest for individuation is going to be successful.

Anima Images - Good	Bad	Good or Bad	Qualities
Beautiful woman Angel ( <u>Angulos</u> - messenger) Nymph Sophia ( <u>Sophos</u> - wisdom)	Ugly woman Serpent Witch Siren Lorelei Femme fatale	Animals Birds High Priestess Moon and lunar images	Moody, vague, Prophetic Feeling for nature Personal love
Animus Images - Good	Bad	Good or Bad	Qualities
Physical man Romantic man Man of action Spiritual man	King of Dead Handsome stranger Death Robber Murderer Bluebeard	Sun and solar images King Father	Cold, obstinate, 'I am right' Arrogance Fatalistic, 'All I want is love'

Extracted from Man and His Symbols, editor Jung, C. G., (London, 1964).

This edition, (London, 1978): 180-198

The question of how the anima can be differentiated and then assimilated, as once again repression and suppression are not viable options, is more difficult than it was with the shadow. In the occidental world there is no education on how to recognise or identify the anima. There are a variety of reasons for this but an excessive reliance upon rationalism must be one

of the contributory factors. The masculine origins of the Western intellectual tradition have established a critical mode of analysis which both excludes 'feminine' intuitive/feeling qualities and at the same time develops the already dominant thinking aspect of the psyche.

It would seem that the shadow is easier to recognise, and perhaps two world wars have helped this, but Western man still has to suppress his so-called 'feminine' traits. Further, anima projections are often so strong that they are not recognised as projections, and information about the nature of the anima, which would dissolve the projection, is highly specialised. The information belongs to the realm of myth, art and religion, hence it is accessible to only a few, and so the cultural individuation process, in as much as it operates at all, remains largely unarticulated.

This inevitably raises the question of whether individuation can be achieved without a conscious knowledge about the process. Presumably individuation can be achieved on an intuitive level, however this is not the norm and for individuation to proceed on a cultural scale it is vital that the shadow, contrasexual archetype and the other archetypes, are recognised and assimilated as conscious parts of the culture. With specific reference to the contrasexual archetype this does not mean that men should be 'effeminate' nor women overtly 'masculine'. Rather for men it means paying special attention to their repressed 'feminine-anima' qualities which will manifest themselves in such areas as creativity and spirituality. For women the process of animus assimilation entails an awareness of women's capacity for decision making, positive assertion and a growth in self identity.

Within the process of anima assimilation there are three stages which can be identified, these are: objectification, division and separation. Each

of these stages is discussed below and seen in relationship to the wider process of individuation. Special attention is paid to the hero-detective's anima assimilation as it is represented in film.

Anima or Animus Assimilation:    1. Objectification

During this phase it is the role of ego-consciousness to identify and accept the functioning of the contrasexual archetype. The more personally this archetype is taken the better because as Moreno comments, '... the ego has to get the right idea of the power and factors ruling the "other world," the world of the unconscious'.<sup>1</sup> For the hero-detective this process involves him in accepting, and then using the 'female side' of his personality. This 'female side' corresponds to the positive attributes of the anima, thus many of these helpful and attractive qualities can be observed in the behaviour pattern of the detective.

For example the detective's reliance upon the hunch, seems to place a value on 'intuitive functioning' which in western culture is traditionally mythologised as a female anima attribute. The hunch is of course associated with the detective's search for truth, as mentioned the Greek for truth or wisdom is Sophos, and the mythological roots of this anima association with Sophos can be found in the proto-typical detective story of Sophocles's Oedipus Rex. During this myth Oedipus goes to consult the Delphic oracle who will give him an honest, if ambiguous, answer to any question that he asks of her. The Delphic oracle, being an anima projection, has of course good and bad qualities, and the fateful end to the myth is well known. What is significant is the association between the proto-detective figure of Oedipus

---

<sup>1</sup> Moreno: p54

and the anima projection of Sophos which takes the form of the oracle. It is also interesting to note that the oracle lived in a cave and the Greek word used by Sophocles for this case is Stormion, which means either a small mouth or vagina. At the centre of this Stormion rests the Omphalos the centre of the world - literally its navel. It is there, in a vagina, at the centre of a cosmological mandala that Oedipus arrives to search for Sophos. So from the beginnings of the detective mythology the hero, and hero-detective, have found that truth is associated with the anima and with female sexuality, and as shall be later demonstrated the same is true for the detective as he appears in films.

Once the detective has identified the anima aspects of his personality he is then equipped to continue on his inner journey and further explore the maze-like world of the unconscious. In the early detective film the detective exists in the world of consciousness which may be imaged as country house as in The Kennell Murder Case, (Dir. M. Curtiz, Warner Brothers, 1933). But by the time of Film Noir in the nineteen forties the detective has truly descended into the underworld, into the depths of his own unconsciousness.

#### Anima or Animus Assimilation: 2. Division

This phase of individuation involves the division of the ego from the contents of the anima. The hero-detective has to consciously realise the process by which he arrives at his intuitive hunches. During this phase of assimilation it is important for the hero to first accept his anima (objectification) to then isolate it, (division) and it is only then that assimilation can be achieved. The danger in dividing the ego from the anima contents is that the anima may be projected in some concealed way. This

makes the now disguised anima projection difficult to identify and so its integration with ego-consciousness becomes more difficult.

'Just as we tend to assume that the world is as we see it, we naïvely suppose that people are as we imagine them to be. In this latter case, unfortunately, there is no scientific test that would prove the discrepancy between perception and reality. Although the possibility of gross deception is infinitely greater here than in our perception of the physical world, we still go on naïvely projecting our own psychology into our fellow human beings. In this way everyone creates for himself a series of more or less imaginary relationships based essentially on projection'.<sup>1</sup>

A simpler way of stating the above is, 'Projections change the world into the replica of one's unknown face'.<sup>2</sup> The detective projects his anima onto the world revealing his unknown face and in this case the negative aspects of the anima are projected and personified in the figure of the femme fatale. So in the detective film, especially nineteen forties Film Noir, both the aspects of the anima can be identified. The good aspect reveals itself in the detective's intuitive hunches and the negative qualities of the anima are projected onto the figure of the femme fatale. Thus the psychological principle of opposition and regulation is maintained.

At this point it seems appropriate to refer back to the section of this chapter on the Delphic oracle. In this proto-typical detective mythology an association between feminine sexuality and truth was observed, and the same observation seems to remain valid for the detective myth's later incorporation in film. David Thomson, amongst other writers, has indicated the mystical, sexual and numinous aspects of the femme fatale,

'She sauntered into innocent or weak lives, asking for a light but requiring the soul. She spread langour, a mystically ultimate sophistication of depravity, her silky legs and the legend that some crime undertaken in

---

<sup>1</sup> C. W. 8: 507

<sup>2</sup> C. W. 9, II: 17

the dark would be as thrilling and as sweet as the unlimited, intricate experience she offered herself'.<sup>1</sup>

Despite the somewhat sensationalistic style adopted by Thomson he has clearly identified both the spiritual and sexual natures of the femme fatale. In these respects he finds her mythological ancestry in such figures as the Sirens and Lorelei who seductively lured men to their death.

However it is important to stress that the femme fatale is only secondarily a sexual figure; primarily she is a personified projection of an archetype and because of this she is attractive as a numinous, or religious figure, and Jung has even referred to the anima as the archetype of the spirit. As noted above in the Oedipus myth there is a relationship between truth and sexuality and here too, in the femme fatale, sexuality and spirituality are interwoven. Just as the Delphic oracle needed a cave, or vagina, to live in so the detective's negative anima projection seems to need the darkness of Film Noir's city streets. As Place notes,

'The characters and themes of the detective genre are ideal for film noir. The moral and physical chaos is easily expressed in crime: the doomed, tortured souls seem to be at home in the violent, unstable milieu of the underworld. The dark woman is comfortable in the world of cheap dives, shadowy doorways and mysterious settings'.<sup>2</sup>

Film Noir as principally a technical style is established by high contrast lighting, extensive use of 'night time' locations and often a city environment. As Place has commented, these elements seem to combine to give the archetype of the anima, a sensual woman a powerful, or numinous portrayal. 'Visually, film noir is fluid, sensual, extraordinarily expressive,

---

<sup>1</sup> Thomson, D., Deadlier than the Male, (London, 1982), from 'The Movie', Vol.3: p590

<sup>2</sup> Place, J., 'Women in Film Noir', from, Women in Film Noir, Edited Kaplan, E. A., (London, 1978): p41

making the sexually expressive woman, which is its dominant image of women, extremely powerful'.<sup>1</sup>

Before the advent of Film Noir the femme fatale as portrayed in film was only a minor figure, the fore-runner of which can be recognised in the gangster's moll. Throughout the nineteen thirties the femme fatale figure becomes more and more important and this is particularly true of two of Sternberg's films, The Devil is a Woman (Dir. J. Sternberg, Paramount, 1935) and The Blue Angel (Dir. J. Sternberg, UFA/Paramount, 1930). Even the titles of these films indicate the presence of the anima, and of course the 'star' of both these films is one of the most apparently alluring of all the femme fatales - Marlene Dietrich.

In The Blue Angel, Marlene Dietrich plays an attractive cabaret performer called Lola Lola, who succeeds in seducing the local school teacher, Professor Immanuel Roth. He falls in love with her and she willingly accepts his proposal of marriage. It appears that all is going well and that they will both live a happy life, but in the scene following the wedding breakfast the Professor is portrayed as a broken man. He is stripped of his albeit pompous, dignity and is forced to work in the cabaret selling pictures of his wife. (Something he had vowed never to do). He appears not to have heeded the warning in the song Falling in Love Again which Lola Lola sang for him,

'Men cluster to me  
Like moths around a flame  
And if their wings burn  
I know I'm not to blame.

The Blue Angel

---

<sup>1</sup> Place: p36

After this he sinks even lower and has to become a clown, not a clown in his own right but an object of ridicule for the cabaret magician, who conjures up eggs and then breaks them over the Professor's head. His final ignominy is to return to the town where he was school master and while he is on stage to suffer the taunts of the crowd. At this point Lola Lola takes a lover and unable to cope the Professor returns to his old school room to die clutching his desk. It would seem that his relationship with the femme fatale has robbed him of his desire to live.

The plot of The Devil is a Woman is similar to The Blue Angel in that the femme fatale figure, Concha Perez, again played by Marlene Dietrich, succeeds in ruining the lives of the men she seduces. In this film Don Pascal is led up the garden path as Concha Perez extracts huge sums of money from him, before finally vanishing. She repeats this escapade a number of times before Don Pascal becomes disenchanted with her, and vows never to see her again. However she still succeeds in engineering a duel between him and his closest friend, in which he is seriously wounded. So as in The Blue Angel the anima projection of the femme fatale manages to destroy the lives of those who try and possess her.

However it is principally in the nineteen forties and in Film Noir that the femme fatale comes to the fore. For example, Veronica Lake in This Gun for Hire, (Dir. F. Tuttle, Paramount, 1942); Rita Hayworth - The Lady from Shanghai, (Dir. O. Welles, Columbia, 1947); Hazel Brooks - Sleep my Love, (Dir. D. Sirk, United Artists/Triangle, 1947). The list could easily be continued and it serves to indicate the preponderance of anima images in film. Another example of the nineteen forties Film Noir femme fatale film, already examined, is The Woman in the Window, (Dir. F. Lang, RKO, 1944).<sup>XI</sup>

To briefly restate the plot, Richard Wanley a criminal psychologist, played



by Edward G. Robinson, is seduced by a portrait of the beautiful Alice. When he eventually meets her he goes back to her apartment where after being attacked, he ends up killing her ex lover. As the investigations of the police progress and as an attempt to kill a blackmailer fails, Wanley decides to kill himself by taking an overdose of pills. However at this moment he is wakened by a waiter and the viewer realises that the whole drama has been a nightmare dream by Wanley.

It is no accident that Lang situates the whole drama, and consequently the femme fatale figure, within a dream. By doing this he emphasises the psychological, as opposed to purely dramatic function, of the femme fatale, and enveloped by a dream she becomes almost as elusive and illusory as her portrait. It does seem as though there is a correlation between the appearance of Film Noir and the femme fatale. The key to understanding this exists in the previously cited occurrence of the anima's negative qualities in the Oedipus myth. It is quite simply that the negative anima needs darkness, sexuality and truth before she can exist. As Thomson remarks, 'The femme fatale was always a phantom that man invoked to justify their own fears'.<sup>1</sup> Thomson is mistaken in claiming that the femme fatale is evoked to justify men's fear. Rather she is an expression of a deep mistrust of the unconscious and of the anima, which is a mistrust of man's own 'feminity'. So on a cultural scale societies project a collective archetypal anima on the screen, and the femme fatale is at once a representation of the detective's anima and of a cultural anima. As Place notes, 'Myth not only expresses dominant ideologies - it is also responsive to the repressed needs of the culture. It gives voice to the unacceptable archetypes as well .

---

<sup>1</sup> Thomson: p593

<sup>2</sup> Place: p36

To return to the theory of analytical psychology, and especially the individuation process, it is vital that once the projections of the unconscious have been identified that they are dissolved - that is, removed. Not to dissolve a projection is to continue living in a world that is formed from unconscious images. This in fact represents the antithesis of individuation whose aim is to expand conscious awareness through making conscious the latent unconscious elements in man's psyche. So the detective must recognise that just as the 'criminal-shadow' is part of his psyche, so too is the 'femme-fatale-anima'. He has to accept and embrace his anima otherwise he will remain possessed by some unknown, unnamed inner force that maintains mastery of his conscious mind.

Anima or Animus Assimilation: 3. Separation

During this phase it is important to stress that separation does not involve separation from the collective. Rather, as with all the stages in the individuation process, the collective nature of the individual is acknowledged while still asserting a person's original and distinctive characteristics. As Jung comments, 'Individuation does not shut one out from the world, but gathers the world to oneself'.<sup>1</sup>

'The fact that individual consciousness means separation and opposition is something that man has experienced countless times in his long history. And just as for the individual a time of dissociation is a time for sickness, so it is in the life of nations. We can hardly deny that ours is a time of dissociation and sickness... The word "crisis," so often heard, is a medical expression which always tells us that the sickness has reached a dangerous climax'.<sup>2</sup>

However the crisis event may also represent a positive stage in the individuation process. Originally the word crisis referred to the place that

---

<sup>1</sup> C. W. 8: 432

<sup>2</sup> C. W. 10: 290

winner of the Greek Olympic games would stand to receive their medals, thus the crisis was a place of honour, respect and achievement. In individuation the separation of the anima, which may result in a 'crisis', points towards the goal of this phase which is the conquest of the anima as autonomous complex and its transformation into a relationship with consciousness. The result of this is that the ego becomes the recipient of the anima properties and the detective is now able to move forward into a new phase of individuation in which the femme fatale is absent.

Whether the detective's individuation as it is represented in film moves past this point is uncertain. In fact some Post-Jungians, Hillman and Samuels, regard the individuation process as a life long dialogue between consciousness and the objective psyche and to this extent individuation may never be fully achieved, for after all the objective psyche represents the totality of man's unconscious experience and programming. They have also suggested that it is only in death that total individuation is possible. Whatever, the fact that the detective film genre does not encompass the whole individuation process should not present a problem. For it is clear from the specific analysis of films, and from general comments on the detective's individuation process that he is an incarnation of the hero and as such is inevitably involved with the mythic, archetypal process of individuation.

It is interesting to note that in many ways narrative elements and the mise-en-scene of the detective film seem to represent different aspects of the detective's psyche - the film often centering around, or, being confined by, one specific location. This may be a country house, a church, or in the case of later detective narratives, the city, and this confinement represents, symbolically, the boundaries of the detective's psyche. Contained

within his psyche there is a persona, which may be that of the 'Gentleman-detective' or the 'Thinking detective', or later the so-called 'Hardboiled-detective', and his shadow is projected and personified in the figure of the criminal. As previously mentioned his anima is personified and projected onto the figure of the femme fatale and the crimes that are committed can be regarded as complexes that exist within the detective's psyche.

So the detective's search for truth is in fact a metaphor of his search for individuation. Thus the solving of a crime symbolically represents the resolution of a complex and a movement into the next stage of individuation. It may also be possible to regard the very location of the detective's search, that is the criminal underworld, as an image of the underworld of the detective's psyche, that is of the objective psyche. The images of the detective film are regarded both as projections of the detective's psyche and as collective societal projections. To this extent the inner and outer worlds, that is the unconscious and the projected unconscious, are indivisible. The way in which the images and mythology of the detective film are representations of his psychic reality is illustrated overleaf.

To return specifically to the theory of analytical psychology, it is important to stress, once more, that the phase of anima assimilation does not treat the anima archetype as a discrete archetype but regards it as related to the other archetypes of the objective psyche. As such the arrival of the anima was pre-figured in the persona and shadow stages, and its own arrival prepares the way for the final phases of individuation. These phases take the questing hero on his search for truth and meaning even further into the unknown depths of the objective psyche, to a place where the figure of the wise old man dwells.

A Diagram Illustrating the Detective's Psyche

Both in terms of Analytical Psychology and of its Mythological  
Filmic Expression

FIELD OF COLLECTIVE CONSCIOUSNESS

Consciousness - Mythology, day

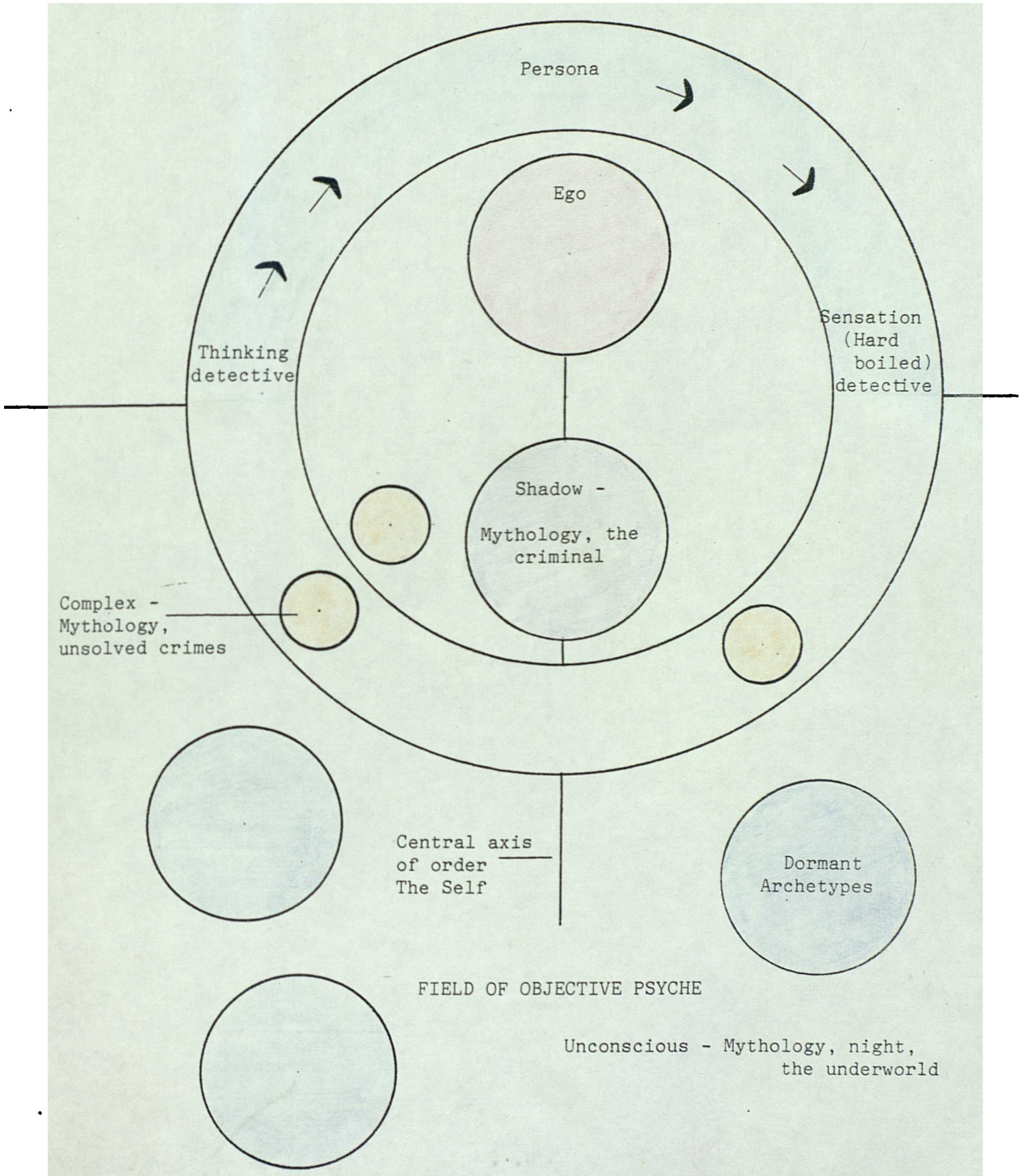

'Only when all props and crutches are broken, and no cover from the rear offers even the slightest hope of security, does it become possible for us to experience an archetype that had up till then lain hidden behind the meaningful nonsense played out by the anima. This is the archetype of meaning, just as the anima is the archetype of life itself'.<sup>1</sup>

Overleaf is a revised schematic diagram of the individuation process. This will help clarify what new elements have been added in the discussion of the phases of individuation.

### DIRECTIVE PHASE

#### Mana Personality

This phase in individuation marks the appearance of mana personalities. The word 'mana' is a term that Jung borrowed from anthropology and is Melanesian in origin. It refers to a compelling 'supernatural' power which comes from the inhabitants of the spirit world. A current English word which is equivalent to this term is charisma which means: of the spirit.

'Mana suggests the presence of an all-pervading vital force, a primal source of growth or magical healing that can be likened to a primitive concept of psychic energy'.<sup>2</sup>

This mana energy should not be confused with numinosity which refers only to the divine presence associated with archetypal functioning. Mana energy is rather the quasi divine power which belongs to the magician, priest, doctor, trickster, saint or any who integrates the anima, either in actuality or in a mythical sense. Figures possessing a mana personality are characterised by wisdom, knowledge, insight, reflection, readiness to help those in peril. However these characters have an ambivalent attitude and,

---

<sup>1</sup> C. W. 9,I: 66

<sup>2</sup> Samuels, A., Shorter, B., Plant, A., A Critical Dictionary of Jungian Analysis, (London, 1986): p89

The Phases of Individuation - Revised Schematic/Diagram

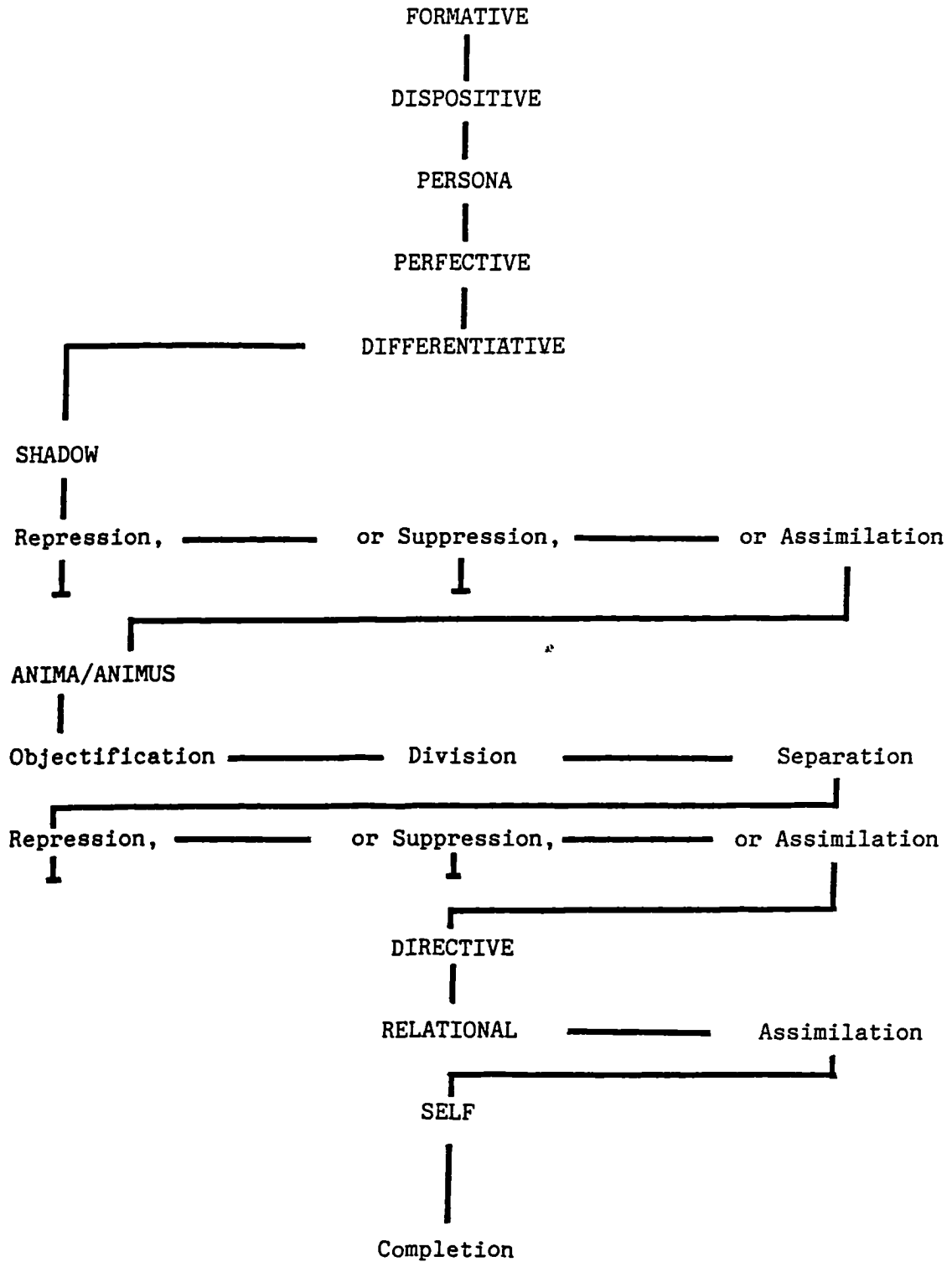

depending upon decisions made by the individuating ego, they can work for either good or bad.

The principal stage at which these mana personalities occur comes after the anima and animus have been divested of their own magical force. The mana figures, which occur at this post anima point, appear as spiritual personalities, often in the same gender as the individual experiencing the mana energy. Typically they occur as a wise old man or woman, the great mother or father (Jung himself had a relationship with such a figure called Philemon whom he both painted and spoke with repeatedly<sup>XII</sup>). Jung comments that these mana personalities adhere to,

'... the desired "mid-point" of the personality, that ineffable something betwixt the opposites, or else which unites them, or the result of conflict, or the product of energetic tension: the coming to birth of personality, a profoundly individual step forward, the next stage'.<sup>1</sup>

It is curious that detective films are characterised by a strange lack of mana personalities. This is especially interesting when other films, which share what is the same mythologem - the quest - are populated almost to excess with such figures. For example in George Lucas' Star Wars trilogy there are the figures of Obi Wan Kenobi and Yoda. Quite why within the particular mythology of the detective quest such figures should be so rare, is uncertain. Of course they do occur and the character of Gaf in Blade Runner, (Dir. R. Scott, Columbia, 1982) is such a figure, and perhaps the emergence of these characters is one way in which the genre will develop. In fact if the detective genre is not to stagnate, then, according to Jungian method, such a development is essential. It is also possible that the detective's genre association with Chinatown may point to a location

---

<sup>1</sup> C. W. 7: 382



from which these mystical spiritual mana personalities will arrive, as Chinatown has been traditionally associated with the mysterious and quasi-magical aspects of the detective's life.

To return to the theory of this phase, the mana personalities occur whenever the ego is consciously confronted with an image of the Self. Again this phase and its associated archetypes are regarded as part of a relational system. While the archetypal process of individuation has been outlined in a linear fashion, the individuation process is much more akin to a spiral. In this spiral the different phases of the process lie above and below each other, all inter-relating as parts of a complicated system. In fact the popular puzzle of the Rubick's cube can serve as a useful illustration of the individuation process.

In this illustration, diagrammed overleaf, the cube represents the psyche and the colours on the cube the archetypal patterns. As the puzzle starts, all the colours are mixed up, and gradually, through various transformational twists and turns, it is possible to complete one face. This represents the completion of one phase in individuation, for example the assimilation of the shadow. In completing this phase all the archetypes have been used and all are rotating around a central axis which is the archetype of the Self. Gradually each face of the cube is completed, but only at the expense of undoing previous work, as the first completed face must be undone before the next two can be completed - and so it continues. At the end of the puzzle each side is separate but still connected to the other faces. In other words a balanced relational system has been created, one in which opposition is transcended by completion of the archetype of the Self. As Moreno notes,

'The integration of the mana-personality through conscious assimilation of its contents leads us back to ourselves as an actual living "something" poised between two world pictures and their discerned potentialities. This "something" is a virtual center that claims everything. Jung calls this center the self. The self is, therefore, the new archetype which will finally solve the problem of individuation'.<sup>1</sup>

### Ego to Self

A representation of the interrelated yet separate nature of the archetypes engaged in the individuation process.

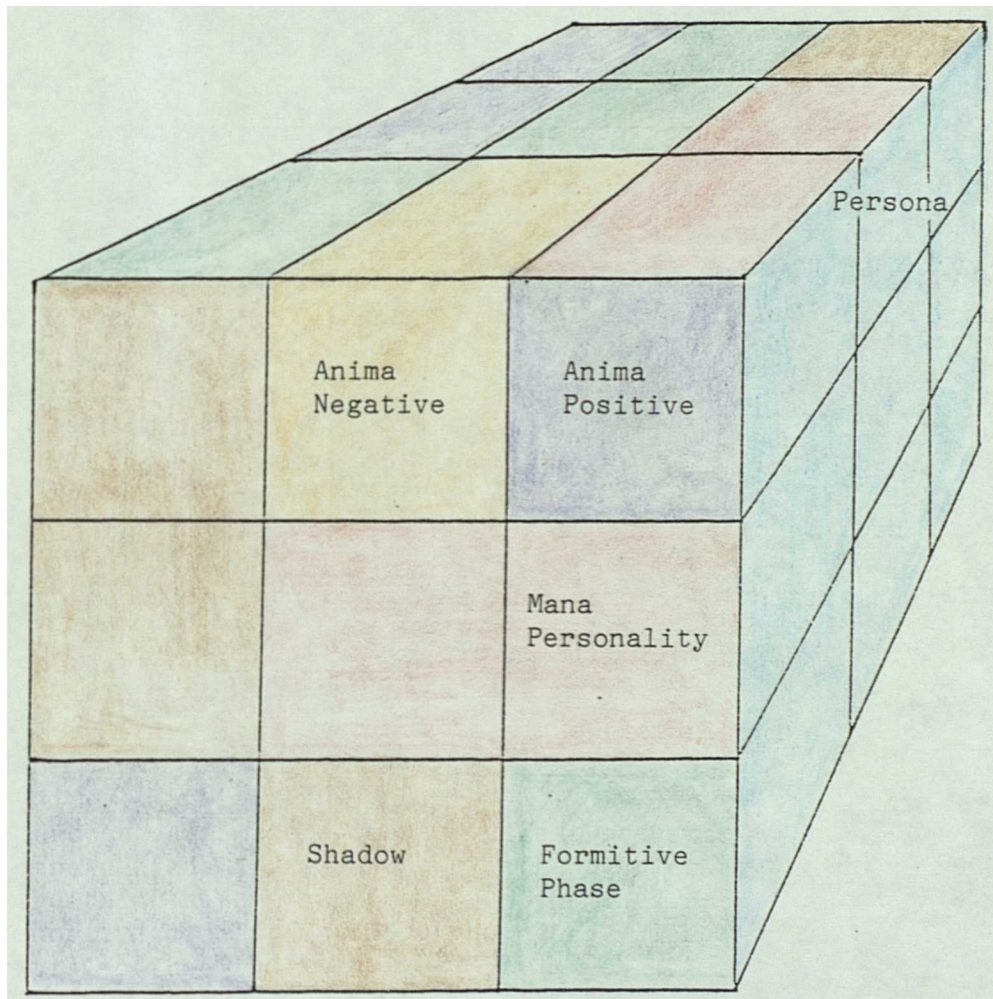

<sup>1</sup> Moreno: p60

THE ARCHETYPE OF THE SELF

The final stage in the individuation process is, as mentioned by Moreno, the constellation of the archetype of the Self. Even though the detective does not reach this stage it still seems important to include this theory. The reasons for this are two-fold. First individuation is regarded as a process which culminates in the emergence of this archetype, and without this information the whole procedure seems somewhat pointless. It would be like running a race without knowing why you were running it, or where you were running to. So for a complete and comprehensible theory of the individuation process to be established information about the Self must be included. Secondly information about the Self helps to place the detective within the correct psychological perspective, and lets the analyst see how far down the path of individuation he has progressed. Without knowledge of the Self, a highly misleading picture would be formed. This information also helps the analyst to predict the future psychological development of this figure.

To progress with the theory, the archetype of the Self is the centre of everything in the psyche, both conscious and unconscious, good and evil, feminine and masculine etcetera. As such, the Self unites these opposites and operates as the centre of the entire psychic system. The Critical Dictionary of Analytical Psychology defines the Self as:

'An archetypal image of man's fullest potential and the unity of the personality as a whole. The Self as a unifying principle within the human psyche occupies the central position of authority in relation to psychological life and, therefore, the destiny of the individual'.<sup>1</sup>

---

<sup>1</sup> Samuels, A. et al., A Critical Dictionary of Jungian Analysis: p135

However the archetypes of the Self cannot be considered apart from the archetype of the Imago Dei for there is close relationship between these two archetypes and perhaps the link is a common numinosity. As von Franz has commented,

'The goal of individuation as pictured in unconscious images, represents a kind of mid-point or centre in which the supreme value and the greatest life intensity are concentrated. It cannot be distinguished from the images of supreme value of the various world religions'.<sup>1</sup>

Historically Jung discovered the archetype of the Self as a spiritual concept in the oriental religious traditions of Hinduism and Buddhism. It seems that the Hindu teaching on ātman particularly influenced Jung's thought. This concept teaches the 'divine being pervades the whole world and is found eternally within the individual. Divine being is thus the supreme Self'.<sup>2XIII</sup> Within the Hindu tradition the Self is represented by images of wholeness or completion such as squared circles or quaternities and Jung has termed these images mandalas. For him they represent the Self as the centre of a balanced psychic system, and they denote that the individuation process is coming to an end. 'The mandala as the centre is the exponent of all paths. It is the path to the centre. To individuation'.<sup>3</sup>

The concept of the Self as equivalent to the Imago Dei is not foreign to occidental thought and can be found within the Christian tradition. The first chapter of Genesis comments,

So God created Man  
in his own image,  
In the image of God  
he created him;  
male and female  
he created them'.<sup>4</sup>

---

<sup>1</sup> von Franz, M. L., C. G. Jung His Myth in Our Time, (Germany, 1974): p73

<sup>2</sup> Smart, N., The Religious Experience of Mankind, (USA, 1969): p125

<sup>3</sup> Jung, C. G., Memories, Dreams, Reflections, (London, 1963): p195-196

<sup>4</sup> The Bible, New International Version; (London, 1979), Genesis 1: 67

Again in the Christian tradition the quaternity of the cross forms the basis for many mandala like patterns and often these patterns are in-filled by a meandering line which represents the psychic growth of individuation. Further Jung has affirmed the relationship between individuation and the Imago Dei by commenting, 'Individuation is the life in God, as mandala psychology clearly shows'.<sup>1</sup>

An Infilled Cross Design

Revealing the process of psychic growth

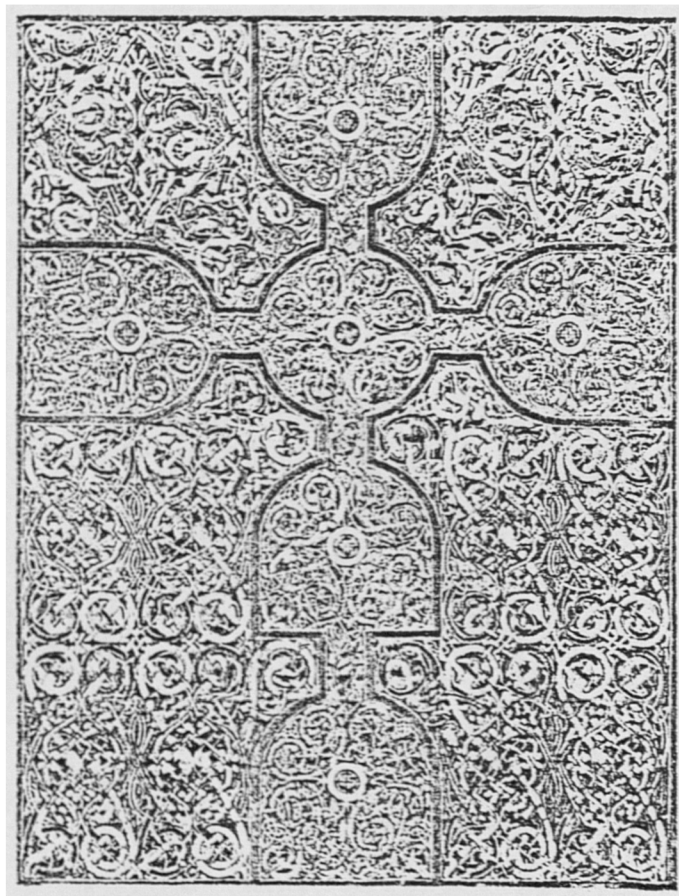

From: Man and His Symbols, (London, 1964)  
This edition, (London, 1978): 160

---

<sup>1</sup> C. W. 18: 1624

To return to a definition of the Self, Jung goes further than merely regarding the Self as the centre or axis of the psyche.

'The self is not only the centre, but also the whole circumference which embraces both conscious and unconscious; it is the centre of this totality, just as the ego is the centre of consciousness'.<sup>1</sup>

It is part of the individuation life process that the Self must be first recognised and then realised as the centre of the psyche, but there can never be more than a hope of integrating part of the vast totality of human existence, which is the Self, within the limited sphere of human consciousness. So the relationship between ego-consciousness and the Self is a life long dialogue whose eventual outcome is uncertain, and all that can be predicted with certainty is the inevitability of the dialogue.

It has been shown in the above discussion that a clear distinction between the theory of analytical psychology and the function it studies is not possible, nor is it desirable. The developing psychology of Jung is a reflexive psychology. This means that it accepts as a psychological truth and necessity that the theory will be changed by what it studies, and that in turn its subject matter will be changed by the theory. Thus the theory and subject are bound together in an organic, self developing and regulating system, which is a perfect paradigm for the relationship between ego-consciousness and the unconscious.

To conclude this chapter are two quotations, both of which acknowledge the inter-relationship of theory and subject in analytical psychology, and which stress the importance of the individuation process.

---

<sup>1</sup> C. W. 12: 44

'He (the analyst) is not just working for this particular patient, who may be quite insignificant, but for himself as well as his own soul, and in so doing he is perhaps laying an infinitesimal grain in the scales of humanity's soul. Small and invisible as the contribution may be, it is yet an opus magnum... The ultimate questions of psychotherapy are not a private matter - they represent a supreme responsibility'.<sup>1</sup>

'Mankind is the only form of life yet known that can bear the tension of these two universes (conscious and unconscious), and perhaps bring them into harmonious relationship. Through the work of mankind the universe may become more conscious of itself. And the ONLY known carrier of this immense process is the individual human being, toiling in the personal and unique process of individuation'.<sup>2</sup>

This chapter has examined the process of individuation and has shown that it is the central, uniting concept of analytical psychology. The different phases of individuation have been seen in relationship to a variety of films, which has further strengthened the links between Jungian and film theory. Now that the theoretical basis for the model, established in Chapter Four, has been completed, it is appropriate to use the model to provide the framework for an indepth film analysis. Responding to this need, Part Three of the thesis is a detailed demonstration of the model. This both tests the model and provides a final in-depth example of how analytical psychology can be used for film analysis.

---

<sup>1</sup> C. W. 16: 449

<sup>2</sup> Hall, J. A., The Jungian Experience: analysis and individuation, (Canada, 1986): p124

CHAPTER SEVEN NOTES

- I. c.f. C. W. 11: 444
- II. c.f. Stevens, A., Archetypes: A Natural History of the Self, (London, 1982): p72-73. (Also c.f. Note X).
- III. c.f. The analyses of Tightrope (Chapter Three: p84) and Blade Runner (Chapter Five: p138), Chapter Six: p159.
- IV. This section builds on the already established idea of the persona. For a more comprehensive definition c.f. Chapter Three: p84 and Glossary. To see the concept of the persona applied in film analysis c.f. Chapter Eight: p227.
- V. The opposite is true for women, here the ideal picture of a woman is compensated with a masculine weakness in the animus.
- VI. This is a development of the earlier examination of the shadow as presented in: Chapters Three: p90-96; Four: p122; Six: p174-176. It summarises the theoretical basis for the archetype of the shadow and places it in relationship to the anima and persona. This prepares the way for the analysis of Trancers (Section Three) in which the archetype of the shadow is important, c.f. Chapter Eight: p242-246.
- VII. c.f. Man and His Symbols: p181-182.
- VIII. c.f. Chapter Three: p84.
- IX. c.f. Chapter Four: p122
- X. Some Biologists claim that archetypes are contained within the DNA code and this explains how these patterns remain independent of culture and history, c.f. Stevens: p239 and p297.
- XI. For a more detailed analysis c.f. Chapter Six, The Symbolic Search: p177-180.
- XII. c.f. Memories, Dreams, Reflections: p207, p215, p252.
- XIII. For a more comprehensive account of the Hindu teachings on ātman c.f. Chandogy Upanishad, VI, B.



PART THREE

A FINAL CASE STUDY:

TRANCERS, THE INDIVIDUATION OF JACK DETH

Chapter Eight

Archetype's Image and Archetypal Pattern

'The image alone is the immediate object  
of knowledge'.

Jung, Medicine and Psychotherapy

INTRODUCTION

This chapter is a detailed analysis of the film Trancers, (Dir. R. Band, Lexyen Productions, 1984). It applies the theory examined in the previous chapters in an attempt to see how relevant and useful analytical psychology is as a tool for film analysis. The analytical model established in Chapter Four, and applied in Chapter Five, provides the structure and methodology for the following analysis. (For ease of reference the model is reproduced in Appendix III). As presented in this chapter, the model has undergone a slight development, and rather than regarding the individuation process as two separate points of interaction within the model, there is now only the one. The rationale for this is that the individuation process is dealt with constantly throughout the chapter, and consequently the final section on individuation can be devoted to the individuation of Jack Deth, the film's hero.

As in the analysis of Blade Runner, (Dir. R. Scott, Columbia, 1982) (Chapter Five) the central guiding questions of the model are taken as the starting points for each section's discussion. The model is applied in the following order:

- (1) archetypal pattern and archetype's image,
- (2) archetype's image and mythologem,
- (3) mythology and mythologem,
- (4) mythology and archetypal pattern,
- (5) individuation and archetypal pattern with mythologem.

So to start with, the chapter takes a character-based approach and stays close to the film text, but it progresses to examine the mythological and archetypal foundations which are discernible in the film.

At this stage it is wise to sound a cautionary note and to remember that this type of analysis does not consist of searching for impressive archetypal patterns and images. Rather the film should speak for itself, albeit in the arena of analytical psychology. As Samuels comments,

'If analytical psychologists look solely for impressive, numinous material, then they will be tempted to be over-active and over-suggestive... possession of a theory of development is just as likely to over-organise the patient's material, if it is misused, as adherence in an unselective way to a myth based approach'.<sup>1</sup>

It is with this warning in mind that the analysis of Trancers is commenced.

---

<sup>1</sup> Samuels, A., Jung and the Post Jungians, (London, 1985): p199

TRANCERS: A PLOT SYNOPSIS

Before commencing on a detailed analysis of Trancers it will prove useful to have a brief resume of the narrative. The year is 2247 AD and Trooper, Policeman, Jack Deth resigns from the Angel City police force because his superiors have forbidden him to continue his vendetta against the 'trancers', the zombie-like followers of the evil Martin Whistler. However, Deth is summoned by the council of Angel City, Spencer and Ashe, and discovers that Whistler has taken refuge via a time drug 'down the line' in the body of his ancestor Weisling, a twentieth century Los Angeles policeman. Whistler plans to murder the ancestors of the councillors and so remove them from history, leaving him free to take control of Angel City. Deth then goes 'down the line' after Whistler and is sent back to 1984, where he takes over the body of his ancestor Phil Dethton. Leena, Phil's latest girlfriend thinks him crazy but is drawn to Deth's quest after she witnesses his fight with a trancer. He eventually finds Spencer's ancestor Lavery, who unfortunately turns out to be a trancer and who tries to kill him. Then Lavery is killed, probably by Whistler. Leena is convinced that Deth is telling the truth and rescues him, then together they track down Ashe's ancestor, Hap Ashby. Jack Deth lures Whistler into Chinatown by offering to swap Hap for a chance to live in the past with Leena. After a struggle, Deth injects Whistler with the antidote to the time travel drug which sends Whistler's consciousness back 'up the line' to the future, where he has already destroyed Whistler's body. Unable to return himself, Deth stays in Los Angeles with Leena.

ARCHETYPE'S IMAGE AND ARCHETYPAL PATTERNS

In this section the analysis is concerned with discovering the central archetypal patterns that lie beneath the surface narrative structure of Trancers.

This chapter seeks not to regard these patterns as separate discrete archetypes, but as interrelated and interconnected systems. The analytical model in this section prompts the following questions: What archetypal patterns are revealed? How are these patterns expressed: that is to say what images do they adopt? And further, what are their opposite patterns? To answer these questions it will be necessary to refer to the film's text, the subtext, and to the theory of analytical psychology.

Within the narrative of Trancers it is possible to discern three central archetypal figures which are the images of four interrelated archetypal patterns. Each of these three patterns will be examined; however, in accord with the principles of opposition and regulation the first two will be viewed as a pair regulating each other. This pair consists of the hero/shadow, while the remaining figure of the anima is separate.

#### HERO AND HIS DARK SIDE; THE PERSONA AND SHADOW

In this section the hero will first be placed within his historical and psychological context, then the character of Jack Deth will be examined, with special emphasis on the persona, and finally both of these systems will be seen in relationship to the figure of the shadow. No direct reference is made to the individuation of the hero, nor to Jack Deth's specific individuation, as this will be dealt with fully in Sections Five and Six of the analytical model; however, some overtones of this underlying theme are inevitable.

Regarding the general and collective nature of the hero archetype Jung has commented that,

'...the myth of the hero... is first and foremost a self-representation of the longing of the unconscious, of its unquenched and unquenchable desire for the light of consciousness. But consciousness, continually in danger of being led astray by its own light and of becoming a rootless will o' the wisp, longs for the healing power of nature, for the deep wells of being and for unconscious communion with life in all its countless forms'.<sup>1</sup>

The image of the hero as a figure who is longing for the light of consciousness, and who is firmly rooted in the 'deep wells of being', (the unconscious) is relevant for the hero-detective in general and Jack Deth in particular. The hero-detective, as was established in previous chapters, is on a quest for individuation, which equates with the expansion of conscious awareness, and in the mythological language of Jung this is expressed as a longing for light. Yet the hero-detective is enveloped by a curious darkness which seemingly tries to arrest this quest. On the one hand he is searching for light and truth, yet on the other he is existing in the dark underworld of crime and the criminal. This is surely not a surprising state of affairs when the principles of opposition and regulation are remembered, and so in Trancers it is appropriate that the hero-detective is called Jack Deth, the very name connoting a collection of dark and dangerous images. For example; the underworld Hades, death, the devil, suffering etcetera. Jack Deth must not 'go gentle' into the darkness of the underworld, which his name personifies. Rather he must attempt his quest which is the hunting of the shadow figure Whistler, with the certainty that darkness, or crime, can be overcome. In psychological terms, it is only after the dark, criminal shadow, has been defeated that it can be assimilated into the totality of the psyche. It is therefore Deth's role to accept the summons of the council and go down the line to search for Whistler. As Jung notes it is only after the hero has triumphed that the shadow can be assimilated into ego-consciousness.

---

<sup>1</sup> C. W. 5: 299

'The hero's main feat is to overcome the monster of darkness: it is the long-hoped-for and expected triumph of consciousness over the unconscious...The coming of consciousness was probably the most tremendous experience of primeval times, for with it a world came into being whose existence no-one had suspected before. "And God said: 'Let there be light!'" is the projection of that immemorial experience of the separation of the conscious from the unconscious.'<sup>1</sup>

It is worth noting that the development of the hero archetype is not an objectified event, this means that the hero is not somehow removed or separate from humanity. Rather the hero's individuation is inextricably bound to the individuation of the culture in which this pattern is found. Just as Orpheus, on his quest for Eurydice, entered the Greek underworld so too Jack Deth, in his search for Whistler, must descend into the American underworld. These heroes do not enter their underworlds alone, but take with them the culture to which they belong. So Trancers can be interpreted as a mythological representation of the American descent into the underworld, and this is made even clearer when it is remembered that this science-fiction film, ostensibly set in 2247 AD, actually takes place in Los Angeles in 1984 AD. Neumann has commented on the collective responsibility of the hero, and in so doing has affirmed the simultaneity of the hero's underworld and the cultural underworld.

'Thus the hero is the archetypal forerunner of mankind in general. His fate is the pattern in accordance with which the masses of humanity must live, and always have lived, however haltingly and distantly; and however short of the ideal man they have fallen, the stages of the hero myth have become constituent elements in the personal development of every individual'.<sup>2</sup>

From this it can be surmised that in Jack Deth it is possible to find not only evidence of his own quest for individuation, but also reflections of a wider and more general cultural move towards individuation. At this stage

---

<sup>1</sup> C. W. 9,II:284

<sup>2</sup> Neumann, E., The Origins and History of Consciousness, (New York, 1954). This edition, (New York, 1973): p131



it seems appropriate to examine Deth's personality and to do so using the techniques of analytical psychology.

The opening words of the narrative contain many indications about Jack Deth's personality. They are spoken in voice-over and as such, and also as the narrative's opening statement, they are of importance, giving the film's viewers their first glance into this fantastic world, and into the character of Deth.

'Last January I finally singed<sup>I</sup> Martin Whistler out on one of the rim planets. Since then I've been hunting down the last of his murdering cult, he called them trancers, slaves to Whistler's psychic power. Not really alive, but not dead enough. It's July now and I'm tired, real tired'.

#### Trancers

Here, in this symbolic overture to the film's later symbolic narrative transformations, are many clues for the viewer to notice so that he or she too can enter into the mythological process of detection. First, Deth is a detective at least this one aspect to his persona, although exactly what type of detective he is will become clear as his character is explored. Secondly there is his seemingly obsessive quest to hunt down the victims of Whistler and to ensure that they are 'dead enough'. And thirdly the narrative is clearly located in a world where a psychic power with the possibility of mind control exists, and the detective is seen in opposition to the evil use of such fantastic forces.

It is also important to notice the 'spoof' element to this opening monologue. This is reinforced by the Film Noir style lighting, Deth's clothing and visual and verbal quotes from other detective films. This tone is preserved through the film and helps towards the creation of the stereotypical

detective, which in some ways he is. In building up a complete profile of Deth's personality, each of the three areas identified below will briefly be examined and it will be demonstrated that they all find expression in the character of the hero-detective.

With regard to the persona it will be remembered that this is a complex series of inter-relationships between individual ego-consciousness and society. It is a type of character mask designed to make an impression on others. As Jung has commented,

'It is probably no accident that our modern notions of "personal" and "personality" derive from the word Persona I can assert that my ego is personal or a personality, and in exactly the same sense I can say that my persona is a personality with which I identify myself more or less. The fact that I then possess two personalities is not so remarkable, since every autonomous or even relatively autonomous complex has the peculiarity of appearing as a personality, i.e., of being personified'.<sup>1</sup>

While it is important to have a persona, it is equally essential to recognise that it is only a facade, because to identify totally with it would lead to a huge inflation of the ego.

Jack Deth is clearly conscious of his persona, although by itself this consciousness does not alleviate the possible danger of identification with it. He is aware of his appearance, his clothes forming an important part of the mask he adopts for the world. In the twenty-third century he chooses to wear the stereo-typical dress of a twentieth century detective. An ill-fitting raincoat and unshaven face contribute to the 'hard-boiled' persona, and these abrasive qualities are underlined by the dress of the 'troopers' that surround him who, in contrast, are clean shaven and clothed in well-fitting uniforms. It is partly through this mask that Deth isolates himself from

---

<sup>1</sup> C. W. 7: 312

the world, and this traditional detective's persona seems curiously out of step in the futuristic world of Trancers.

This persona forms the viewer's first impressions of Jack Deth and these are swiftly reinforced by the movement of the narrative. As he arrives on screen Deth is driving an old, although futuristic, car which again recalls the traditional persona for the detective. He is quickly involved in singeing a trancer,<sup>I</sup> which entails its destruction, and after this sequence has ended the next time the viewer encounters him he is emerging from the ocean after an underwater exploration of the sunken city of Los Angeles. In many ways there seems to be a genre similarity between the personas of Deth and Ian Fleming's James Bond. Deth, like Bond, is physically strong, attractive to women, engages in dangerous activities like diving, and is himself dangerous. Like Bond he is 'Licensed to Kill', at least to kill trancers. As if to reinforce the film's opening impressions of Deth's persona he is next shown entering the Council Chamber, again wearing his traditional detective's clothing. Here he accepts the Council's request to go after Whistler, flirts with engineer Ruby Rains and, going against the desire of the council, destroys the body of Whistler. He is then sent down the line to protect the ancestors of the Council.

As he arrives in the body of Philip Dethton, his ancestor, Phil is in the act of shaving. Deth looks in the mirror and wipes away the foam, leaving his stubble intact. He is apparently carrying his persona with him and this is quickly emphasised as Leena, a one-night-stand of Dethton's, is introduced.

Deth is able to assume, at least in part, Dethton's persona because he is a relative. According to Jung's archetypal hypothesis, the mother lives on in her daughter and the father in his son. Given this basis it can be seen

that Dethton is 'living on' in Deth, or to be more accurate, the inverse is true; Deth lives in Dethton. When Deth discovers a drawer full of photographs of Dethton's past conquests, he is again contributing to the womanising, Bond-like aspects of his own persona. He quickly finds a raincoat like the one he left behind in Angel City and proceeds to wear it, even though it looks warm outside. He next puts cream in his hair with the remark that, 'Dry hair's for squids', and to complete this duplicate persona he is shown driving an old car that belongs to Dethton. Again Deth's persona, especially the hair and the raincoat, seem to isolate him from the other inhabitants of Los Angeles.

It is only at the end of the film that Deth is really able to abandon his persona. This occurs when Hap Ashby wears a raincoat identical to his so that Whistler is tricked into attacking the wrong man.

Despite this emphasis on the persona it would be wrong to suggest that he has not moved past the persona phase of individuation, as clearly his quest is to capture the shadow figure of Whistler. However it is behind the mask of the persona that Deth hides, and this is one of the first examples of a recurring theme in Trancers, that an outer defence marks an inner battle. Or, put in the terms of analytical psychology, beneath the outer persona there exists an inner battle between the shadow and ego-consciousness.

The film's opening sequences establish the persona aspects of Deth's character, and it may be helpful to reproduce these as a list showing this presentation and development:

- (a) Old raincoat, stubble, car, sings trancer (Traditional aspects of the detective)
- (b) Underwater exploration (Danger)
- (c) Raincoat (persona)

- (d) Fondness for women is shown with engineer Ruby Rains
- (e) Destroys the body of Whistler (Independence)
- (f) In Los Angeles he keeps the persona established in the opening sequence of the film: old raincoat, stubble, car, 'wet hair', a girl and he quickly sings another trancer, who was dressed as Santa Claus.

All this clearly begs the question, why does Deth have this dependence on his persona? It is almost as though the persona gives him some type of protection, a character armour, which defends him against the psychic power of Whistler. It may be that Deth is worried about being tranced himself and perhaps 'squids' are tranceable and this is why he greases his hair. In the film these issues remain unanswered, but the emphasis on the persona may indicate that he is indeed worried about falling prey to Whistler's power, and certain there is some ambiguity on this point. However, as mentioned, identification with the persona brings with it not strength, but ultimately weakness.

An example of this weakness and of the detective identifying with his persona can be found in The Detective (Dir. W. Wyler, Paramount, 1951). The detective, played by Kirk Douglas, is a hardened and bitter man who, without mercy, prosecutes any criminal whom he encounters, regardless of how small their crime may have been. It takes his wife to tell him that, 'You are a cruel and vengeful man and you're everything you said you ever hated in your father'. The detective had become entirely identified with the persona of a detective, and used this as a way of projecting a repressed hatred of his father. At the end of the film he realises this and comments, 'I built my whole life on hating my father, and all the time he was inside me laughing'. The cost of this identification with the persona is death, and in this film the detective lets himself be shot facing an armed criminal in the police station.

To return to the character of Jack Deth in Trancers: on the surface he could be classified as an extroverted-sensation type. Apparently all his energies are directed towards the outer world as his process of investigation and trancer hunting affords little chance for introspection. Again on the surface he is apparently a sensation type motivated by a need for new experiences and gratification of the senses. Deth in the opening moments of the film orders 'coffee' to which he gets the reply, 'What, the real stuff, mister? That's going to cost ya'. But for the sensation type it is worth the money. The intellectual process of detection, the following of clues, and the formulating of traps to capture Whistler, again all seem to indicate an extroverted sensation attitude. However, the above description is only an analysis of Deth's persona. As a hero-detective he knows well that to proceed deeper into himself he has to adopt a feeling attitude, and to let himself become 'affected' by the quest. He has to come to terms with this search and on the one hand let the descent into the underworld possess him, yet on the other hand still keep control so that he does not enter into the inner endopsychic area of invasions. This would end in disaster as he would become overwhelmed by the weight of the objective psyche. As Jung notes,

'It is through the "affect" that the subject becomes involved and so comes to feel the whole weight of reality. The difference amounts roughly to that between a severe illness which one reads about in a text-book and the illness which one has. In psychology one possesses nothing unless one has experienced it in reality. Hence a purely intellectual insight is not enough, because one knows only the words and not the substance of the thing from inside'.<sup>1</sup>

To see past Deth's persona it is necessary to see what other roles, other than detective that is, Deth has ascribed to him or claims for himself. His girlfriend Leena jokingly describes him as a 'dangerman' and even gives him a small toy robot as a Christmas present. While it is unwise to place too

---

<sup>1</sup> C. W. 9,II: 61

much stress on what is essentially a humorous remark the role of dangerman seems to hint at his need for excitement, at his quest to destroy Whistler. At the same time the gift may indicate a weakness, which is that at all costs Whistler must be destroyed. He is 'programmed' to destroy Whistler, and he does not have any control over the quest, being almost a robot himself, almost a trancer. The film is ambiguous on these points, but it is important to note that this scene falls between two trancer-orientated situations. First Deth fights with the 'trancer-like' punks in the disco; next he returns to the flat where he receives his dangerman robot, he is taken briefly up the line, and then returns to find Whistler on a television newscast. He is surrounded by danger, inside and out, and the movement of the film seems to indicate and strengthen that atmosphere.

Deth claims for himself two further roles, first as death and second as a fortune teller. When he is designing the scheme through which to capture Whistler he rings up Whistler and says 'Tell him it's Deth, he'll know'. This occurs towards the end of the film just before the final sequence resulting in Whistler's demise, and in some way it seems to indicate Deth's acceptance of his shadow qualities. As a hero in the underworld he brings with him death. This has been evident throughout the film as he destroys trancer after trancer, but by the end of the film he seems able to accept these deathly qualities and to deal with his shadow. It is also important to note that after the telephone call he is able to transfer his persona-raincoat and let Hap wear it - perhaps Deth is finally moving inward?

The third claim, to be a fortune teller, is fulfilled when he describes Hap Ashby's future to him. Because of his knowledge of future events, he is able to predict that one of Ashby's descendants will become a leader in the twenty-third century. He not only tells Ashby this, but is also involved

in the ritualised washing of Hap which initiates him so that he is ready for his new role.<sup>II</sup> Again this washing occurs just before the final sequence when Deth abandons his raincoat and destroys Whistler. Is he delving deep inside himself and adopting some of the character of the wise old man? Whatever, his prurient nature is surrounded by an aurora of psychic prophecy, and the benign prophecies of Deth (death) find their compensatory opposite in the evil shadow mind-controlling power of Whistler.

Near the start of the film it is disclosed that Deth used his wife as trancer bait. She was killed by a trancer and this seems to form part of his motivation for hunting Whistler, and immediately after this disclosure is the scene with him emerging from the waters surrounding the sunken city. It is almost as though the memory of his wife is somehow kept alive by his investigations into the past. Much as he once used his wife as bait for a trancer, so she, or rather her memory, entices him into the past and into the underworld. Exactly what his feelings are about the death of his wife remains ambiguous, as does the way his wife died. Possibly she became a trancer or maybe she was a 'squid'. It is also possible that he feels guilty about his actions and putting her at risk. On these issues the audience is free to conjecture, but what is certain is that the loss of his wife provides part of his motivation and hatred towards Whistler. Deth is also determined not to let Leena lose her life in the same way,<sup>III</sup> and so is reluctant to involve her in the plot to capture Whistler. Also in some ways Leena, who belongs to the underworld, is a 'type' of Deth's previous wife. Therefore the shadow side of him seems to come from his feelings about his wife's death, which he discusses at length with Leena, and his hatred of Whistler which stems from the loss of his wife. It is ironical that it is this dark side which he hates so much that he must accept if he is to proceed on the quest for individuation.



THE SHADOW

Having dealt with the figure of the hero-detective it now seems appropriate to examine its compensatory opposite, the shadow-criminal. The shadow, like the hero, operates not on just a personal scale but also in terms of a collective psychology. Whistler and the underworld do not just represent a projection of Jack Deth's shadow, but of a wider and more general aspect of the objective psyche.

'With the rise of consciousness since the Middle Ages he (the devil) has been considerably reduced in stature, but in his stead there are human beings to whom we gratefully surrender our shadows. With what pleasure, for instance, we read newspaper reports of crime! A bona fide criminal becomes a popular figure because he unburdens in no small degree the conscience of his fellow men, for now they know once more where the evil is to be found'.<sup>1</sup>

The evil in Trancers is clearly personified in the figure of Whistler, who represents the dark side which Deth must embrace if he is to continue along the pathway of individuation. It should be remembered that there is a similarity between the power possessed by the hero, which is ego-consciousness, and that possessed by the shadow for as has already been shown, both have in the language of Trancers 'psychic powers', or in the language of analytical psychology numinosity. It is not so much that the shadow is evil, it is rather that it has not yet been assimilated into ego-consciousness. So the repressed shadow grows in strength and forces the pace of individuation, and during this time it can either aid or destroy the hero's psyche.

'But just as there is a passion that strives for blind unrestricted life, so there is a passion that would like to sacrifice all life to the spirit because of its superior creative power. This passion turns the spirit into a malignant growth that senselessly destroys human life'.<sup>2</sup>

---

<sup>1</sup> Jung, C. G., The Integration of the Personality, Trans. Dell, M. S. (New York, 1939). (Not in Collected Works): para 69f

<sup>2</sup> C. W. 8: 646

In many ways Whistler represents the antithesis of Deth. Whistler is not physically impressive, while Jack is constantly demonstrating his physical prowess by destroying trancers, rescuing Leena, etcetera. Whistler is the physically weak but cool, calm intellectual villain very much in the vogue of the 'James Bond' films while he represents Whistler's opposite, the physical hero.

The physical nature of Deth is underscored by the appearances of Whistler, which all have an illusory quality and lack the physical presence of Whistler himself. A list of Whistler's appearances will make this clearer.

- (a) In a pre-recorded image at the council (Appendix II,d).
- (b) At a reconstruction fantasy scene. Father Christmas at the North Pole (Appendix II,e).
- (c) In the slow motion time of the ten-second watch.
- (d) On television.
- (e) In the underworld of the warehouse.
- (f) In slow motion time again.

All these appearances of Whistler are illusory, and it does seem as though Deth is chasing a shadow, something that is immaterial. Whistler not only personifies the negative aspects of the shadow, but in his 'phantom' appearances indicates its illusory or shadow-like qualities and all this supports the interpretation of Whistler as a projection of Deth's shadow.

It is also interesting to note that the film is dominated by the illusion of Whistler. At the start of Trancers Whistler is a holographic image, a shimmering ghost, and at the film's end Whistler has gone. His consciousness has been returned up the line and the consciousness of the 'real' policeman Weisling has been returned to its body. The film is wrapped in the fantasy of Whistler and he remains an illusory enemy both to begin and end with.

At this juncture the film is making the psychological point that to regard the shadow as an enemy is an illusion, it is wrong. The shadow is part of being human and must be accepted as such and then integrated into ego-consciousness. Whether Deth achieves this or not will be examined in the section on individuation (Chapter 12). At this point it is sufficient to stress the ambiguity of this, and to remember that if Deth is to progress to the anima phase he must first assimilate his shadow.

The negative aspects of the shadow also find expression in the trancers. As mentioned above, the trancers are 'slaves to Whistler's psychic power' and they have in part been possessed by the dark side of the psyche. They have lost partial control over their conscious senses, and Whistler is able to control their action and even to speak through them. However, once Whistler no longer has any use for a trancer, or after one has been killed, then their bodies are destroyed, they glow red and disappear, leaving a black scorch mark behind.<sup>IV</sup> (The film calls this process singeing).

Both of these events are shadow underworld characteristics. The red outline and heat represents the destruction of the body in a type of 'hell fire', and the black scorch in the shape of the body indicates that these were indeed black shadow figures belonging to the underworld. Within the mythology of the detective genre both the red outline and black scorch are reminiscent of the white chalk outline which is traditionally drawn around the bodies of murder victims.

Trancers at this point neatly ties together both mythological references to the shadow, and internal filmic references, and so it begins to become clear that the film is creating its own mythological underworld. In other words the film is imaging collective and unconscious processes, and in this case

it is the individuation process which is represented via the mythology of the detective genre.

Following this it is apposite to examine one of the narrative subthemes which is the hero incest theme. An act of narrative disclosure occurring at the end of the film, is that Deth, or Dethton; is to marry Leena and the result of this marriage many generations later is Jack Deth. It follows from this that Deth has therefore fallen in love with one of his own ancestral mothers, or as the analytical psychology term has it his 'first parents'. There are two possible explanations for this occurrence and the narrative remains deliberately ambiguous on this point, either Jack Deth remains in the twentieth century and, in an incestuous relationship, fathers himself, or he returns to Angel City and Philip Dethton returns to marry Leena. It may at first appear that Deth has no option but to stay in Los Angeles because there is only one phial of the time travel drug. However the final shot of the film shows one of the MacNulty's ancestors coming out of the shadows, and this ancestor has previously sent Deth up the line. It is therefore quite possible that MacNulty has returned to bring him back to Angel City. Despite this ambiguity it is clear that Deth has the intention to commit incest, and this not only aligns him with the shadow, (it is only necessary to remember the fate of Oedipus to realise this), but places Deth in a clear mythological context. As Neumann has commented,

'Jung has demonstrated that the hero's incest implements his rebirth, that only as one twice-born is he the hero, and that conversely anyone who has suffered the double birth must then be regarded as a hero'.<sup>1</sup>

And later,

---

<sup>1</sup> Neumann: p148

'... the hero's "incest" is a regenerative incest. Victory over the mother, frequently taking the form of actual entry into her, i.e., incest, brings about a rebirth. The incest produces a transformation of personality which alone makes the hero a hero, that is, a higher and ideal representative of mankind'.<sup>1</sup>

This hero incest theme is therefore vital to the narrative and to the development of the hero-detective and also serves to introduce the mythological concept of rebirth into the film. Just as the hero has to be reborn on his quest, so too all on the quest for individuation have to be reborn, and this applies on the cultural as well as the individual scale. A culture, if it is to participate in its individuation, must create its own hero, or as Jung might have said, live its own myth, and this seems to be happening within the detective film genre.

#### THE CONTRASEXUAL ARCHETYPE: ANIMA

At this point it may prove helpful to very briefly identify the archetype of anima as it appears in Trancers. In the history of mythology the anima has assumed a variety of roles; some of these have been positive in nature, but mostly they are highly negative images of women who try to drain and destroy the lives of men. This only shows the fear that did, and still does, exist, which men feel towards their own interior feminine aspect.<sup>V</sup>

Here it is proposed to show that the anima is imaged in one of two ways, either benign or malignant, and that both of these anima images can be found in the figure of Leena.

---

<sup>1</sup> Neumann: p154

Erich Neumann has commented on the many forms that the anima can be imaged in,

'She has many forms, ranging from the innocent virgin who is overwhelmed by the heavenly messenger and the young girl who receives the god in an ecstasy of longing, to the sorrowful figure of Sophia, who gives birth to the divine son, the Logos, knowing that he is sent by God and that the hero's fate is suffering'.<sup>1</sup> VI

In fact Neumann has only elucidated the benign forms mentioned above and it takes only a brief look at the history of mythology to further polarise these two faces of the anima. Beside the receptive virgin is the figure of the femme fatale which was examined in the previous chapter.<sup>VII</sup> The Greek Sirens, the German Lorelei, Lilith, Lamais, vampires and the witches of the Seventeenth Century all serve to indicate the destructive and magical spirit world of the anima.<sup>VIII</sup>

One of the most important attributes of Leena is that she is a 'strong' character, who cannot be tranced. As an anima figure she has a closeness to the shadow, but her strength prevents her from being possessed by it. This strength is vital to Jack Deth because his wife was weak and died, or was tranced, while being used as trancer bait. Leena provides an opposite to this previous weakness in Jack's life, although he still has a fear of losing her to Whistler. This fear is evident in the scene just before the final confrontation with Whistler, where Jack helps dress Leena's gunshot wound which she received in the previous chase. Here Jack describes his worry that it was his own fear of Whistler which put his wife at risk, and his reluctance to put Leena at risk is evident. During this scene Leena's face is shown reflected in a mirror. In this context she seems strong because the viewer and Deth see two images of her.

---

<sup>1</sup> Neumann: p137

It is psychologically right that an anima figure should appear as a reflection for she has to guide and lure the hero past the shadow phase, deeper into the unconscious, to eventually arrive at the anima stage. If she does not seduce the hero he may have to survive without a guide.

It is significant that the double image of Leena is caused by a reflection, as this emphasises the illusory quality of the anima. While the animus is outwardly strong, just as Deth is outwardly strong, the anima assumes the opposite role and is apparently weak, a deceptio visus. As Jung notes, this may result in attraction between the two opposites and this partly explains why Leena and Deth fall in love.

'When animus and anima meet, the animus draws his sword of power and the anima ejects per poison of illusion and seduction. The outcome need not always be negative, since the two are equally likely to fall in love (a special instance of love at first sight)'.<sup>1</sup>

As a result of this attraction Deth is obliged to trust Leena, although, because she is an anima projection, she does not always seem to be entirely worthy of this trust. For example, initially Leena says she will not help Jack, then she tells him that she will act as his guide around Los Angeles. After this she steals his car and leaves him at physical risk from a trancer, and stuck, burning, inside a sun-tan room. Eventually she does return to save him, and this, combined with the romance of their relationship, explains why he, in return, saves her from being shot by Whistler's policemen.

From this point onward in the film Leena is trustworthy and her more dubious skills, for example hot wiring motorbikes, are used to Jack's advantage. She acts as both provider, bringing him food and presents, and guide, direct-

---

<sup>1</sup> C. W. 9, II: 30

ing him throughout the city. As Jung has observed, 'Anima and animus do not only occur in negative form. They may sometimes appear as a source of enlightenment as messengers, and as mystagogues'.<sup>1</sup> Hillman has commented on the role of the messenger, guide or interpreter, and has stressed how important this typically anima role is for the hero.

'The interpreter's role is to help the ego-shade adjust to his underworld milieu. The interpreter is a guiding Virgil, or a Teiresias, or a Charon; he is not a Hercules or an Orpheus. His work is in service of Hermes Chthonios or Hermes Psychopompos, corresponding to the one way direction downward. Hermes takes souls down; the hero standing behind the ego tries to bring them back up again'.<sup>2</sup>

The anima, like Charon, remains in the underworld, moving between two banks and serving to take the hero deeper into the maze of the underworld, that is deeper into the unconscious. She is at once his guide and yet also his undoing. Leena personifies all the aspects of the anima being both a guide, and a mother.

### Summary

To conclude this section on archetype's images and archetypal patterns in Trancers is a summary which lists the key points of the chapter as it stands.

- 1) In Trancers it is possible to discern two key archetypes, the hero and the shadow. It is also possible to discover the contrasexual archetype.
- 2) These archetypes are not discrete but aggregates and should therefore be considered as a group.

---

<sup>1</sup> Jung, C. G., Basel Seminar, (Zurich, 1934): para 48f

<sup>2</sup> Hillman, J., The Dream and the Underworld, (New York, 1979): p108



- 3) This is further substantiated when it is noticed that the hero archetype has his inner shadow projected onto the criminal Whistler, and his anima projected onto the figure of Leena.
- 4) There is established an archetypal cluster or aggregate which contains within its sphere a series of regulating and compensatory oppositions necessary for the hero's individuation.

CHAPTER EIGHT NOTES

- I. c.f. Appendix II, Figures e and f.
- II. c.f. Mythology and Mythologem, Chapter 10: p274.
- III. c.f. The anima: p246-249.
- IV. c.f. Appendix II, Figures e and f.
- V. c.f. The Detective and Individuation: p201-291.
- VI. The darker and malevolent side of the anima is evident in many Film Noir films, one of the most notable of these is Double Indemnity, (Dir. B. Wilder, Paramount, 1944). In this film the 'hero' Walter Neff is dragged deeper and deeper into the underworld as he is persuaded by the femme fatale figure of Mrs. Diedrickson to help murder her husband. Through the attraction of the anima, he is drawn into a fatal confrontation with his own shadow, and unable to cope with his feelings for the anima figure, his shadow drives him to kill her husband. After this he describes himself as a living corpse, not unlike a trancer, 'I couldn't hear my own footsteps. It was the walk of a dead man'. He is unable to cope and the only solution he can find to the problem is to kill the femme fatale, and he succeeds in this, but not before she has shot him. Just as she wounded him psychologically, so she now wounds him physically and this injury will result in his death, either in the hospital or later in the gas chambers of San Quentin prison. From a psychological perspective Double Indemnity not only illustrates the dangerous aspects of the anima, but also shows how the shadow responds to the advances of the anima. The inner man and inner woman walking hand in hand.
- VII. For a detailed account in psychological terms of the contrasexual archetypes, c.f. Chapter Two, Jung's Psychology of the Unconscious: p64.
- VIII. For other aspects of the anima c.f. Chapter Seven: p202.

Chapter Nine

Archetype's Image and Mythologem

'They said to him: Shall we then, being children, enter the Kindom? Jesus said to them: When you make the inner outer and the outer as the inner and the above as the below, and when you make the male and the female into a single one'.

The Gnostic Gospel of Thomas

ARCHETYPE'S IMAGE AND MYTHOLOGEM

It is the function of this section to discover the fundamental or main myth theme, and to then relate the auxiliary myth themes to this, creating a mythological unity. In Trancers the central theme is the quest theme and subsidiary to this are three other important subjects which are; life and death, height and depth, and body and spirit. Each of these themes will be examined and related to the central quest theme. However, before this it is important to examine Jung's concept of Enantiodromia, as this notion underlies much of the mythological material in this chapter.

ENANTIODROMIA AND OPPOSITES

In this analysis of Trancers attention has already been paid to the principles of opposition and compensation. In a sense these principles are an integral part of any analytical procedure and demand that a unit, in this case a film, should be broken down into its constituent parts. However, for analytical psychology, the danger of this process is that as the film is deconstructed, the interrelationship of its various parts is forgotten.<sup>I</sup> This is especially true when the principles of opposition and compensation are being observed. In the search for clarity of meaning it becomes easy to lose sight of an image's complementary opposite. Or rather it is forgotten that it is a complementary opposite and that it exists in a compensatory state to its other half, without which it remains incomplete. As Jung notes,

'The tendency to separate the opposites as much as possible and to strive for singleness of meaning is absolutely necessary for clarity of consciousness, since discrimination is of its essence. But when the separation is carried so far that the complementary opposite is lost sight of, and the blackness of the whiteness, and the evil of the good, the depth of the heights, and so on, is

no longer seen, the result is one-sidedness, which is then compensated from the unconscious without our help'.<sup>1</sup>

While it is vital that as part of this analytical procedure the oppositions contained within the mythological sub-stratum of Trancers are exposed, when analysing the text in Jungian terms they must always be viewed as parts of a regulating and balancing system. Any creative activity which is viewed psychologically is bound to reveal apparent contradictions and oppositions because this is the way in which the unconscious communicates. During analyses of these products of the unconscious, constant reference should therefore be made to opposites and their synthesis. In the following quote Jung is writing about the evolution of psychology but his point is equally valid as a general psychological principle.

'Contradictory views are necessary for the evolution of any science; they must not be set up in opposition to each other, but should seek the earliest possible synthesis'.<sup>2</sup>

Given this imperative, to strive for synthesis, it is important to apply this to the analytical procedure which this chapter is conducting, and to see if it is possible to be consciously aware of the oppositions within the text, and yet still achieve a synthetic, textual, and analytical unity. This is where Jung's concept of Enantiodromia becomes useful.

The term Enantiodromia is one which Jung borrowed and redefined from Heraclitus. The term is composed of two Greek words, Enantio, meaning counter, and Dromia, meaning running, and Jung understands this to be the 'regulative function of opposites', or as Heraclitus puts it, 'The way up and the way down are one and the same'.<sup>3</sup> Jung notes that,

---

<sup>1</sup> C. W. 14: 470

<sup>2</sup> C. W. 18: 1774

<sup>3</sup> Heraclitus, Heraclitus: Greek Text with a Short Commentary, Trans. Marrovitch, M., (Los Andes University Press, 1967): Fragment 30

'Old Heraclitus, who was indeed a very great sage, discovered the most marvellous of all psychological laws: the regulative function of opposites. He called it enantiodromia, a running contrariwise, by which he meant that sooner or later everything runs into its opposite... Thus the rational attitude of culture necessarily runs into its opposite, namely the irrational devaluation of culture. We should never identify ourselves with reason, for man is not and never will be a creature of reason alone, a fact to be noted by all pedantic culture-mongers. The irrational cannot and must not be extirpated. The gods cannot and must not die'.<sup>1</sup>

If everything really does run into its opposite then this has some very important implications for the oppositions discovered within Trancers. Rather than regarding an opposition as a textual hole, that is a place at which the narrative fabric deconstructs itself, opposition becomes a unifying and solidifying occurrence. For example, the fact that Jack Deth is on a search for life strengthens his mytho-symbolic structure and hence its narrative importance. Again Deth descends into the underworld to fight crime, and in Trancers this 'underworld' is the world of Los Angeles 1985. The inner underworld and outer world of Los Angeles have become one, and through this cohesion the mythological elements of the narrative are bonded into a diverse, yet unified structure. The result of this is that if deconstruction, within the terms of analytical psychology, is properly conducted, then there is the discovery of a new and deeper mythological level. So while this analysis does discriminate and search for opposition in the attempt to explore the meanings of myths and symbols, it does so not to explain away their presence, neither is it an attempt to deprive them of their numinous and ultimately unknowable substance. All that is happening is that deconstruction reveals a newer and deeper mythological level. So within a properly conducted film analysis both Jung's demand that myth and symbols remain irrational, and the analyst's need to know just what is going on beneath the surface, remain compatible. Indeed they may themselves be regarded as

---

<sup>1</sup> C. W. 7: 111

part of an Enantiodromaic system, as Hillman notes,

'So it is a mistake to treat Jung's opposites with logical tools, as if he were making logical moves. Because his oppositions are not logically exclusive contradictories, anima does not exclude animus, and we can be conscious and unconscious at the same time, and so on. That is why Jung so often rejects "either/or thinking" in preference to "both". His pairs are antagonistic and complementary at the same time, but never contradictories'.<sup>1</sup>

Having stressed the importance of opposition, and shown it to provide mythological cohesion, it is now proposed to examine the three pairs of opposites listed at the start of this chapter; height and depth, life and death, body and spirit, and all of these will be seen with reference to the central quest theme. First, then, a brief introduction to the quest theme.

#### THE HERO'S QUEST OR ADVENTURE

So far in this chapter reference has been made to the hero-detective's quest and this has been seen as a linear quest for truth. By this is meant that the detective follows a series of consecutive clues, which when properly interpreted will enable him to solve the crime under his consideration. Further this search or quest for truth has been equated with the detective's own search for individuation and so he is placed firmly in both a mythological and psychological landscape - indeed the one is taken to be a projection of the other. This simple linear quest model is accurate, so far as it goes, but it is possible to produce a more detailed general cyclical model which breaks down the quest into its component parts. This again is a general model and shows the universally recurring sections and order of the quest motif. What follows is first a diagram illustrating this quest, and then an indication of how this links to Jack Deth's quest in Trancers.

---

<sup>1</sup> Hillman, J., The Dream and the Underworld, (New York, 1979): p75-76

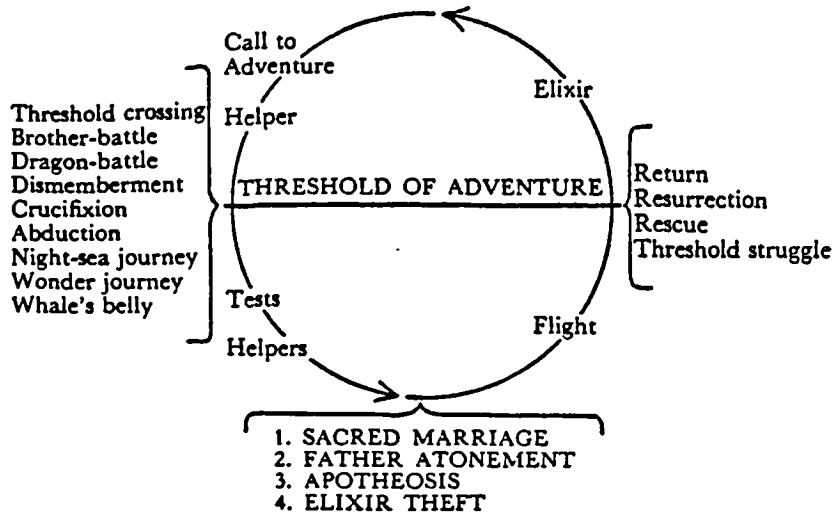
The Hero's Quest Motif

Extracted from The Hero With A Thousand Faces, J. Campbell, (New York, 1949),  
This edition, (London, 1968): p245

At the head of the circle there is the call to adventure, and Jack Deth is indeed called, as first he resigns from the police force and is then summoned by the council to hunt Whistler. Perhaps of more importance to Deth than the council's call is his own inner call, or vocation, as first of all he ignores the summons of the council and only accepts the quest when he discovers that, 'Whistler's alive!'. As also mentioned the loss of his wife to Whistler's trancers may also play an important part in his motivation.

The first helper that Deth encounters is Ruby, one of the council's engineers, who is to look after his body after she has sent his consciousness 'down the line' into the body of Philip Dethton in 1985. With Ruby's help, Deth crosses the threshold of time, goes down the line and enters the underworld of Los Angeles in the body of Dethton. Here he undergoes his first test, to find the ancestor of Chairman Spencer and to find him before he is killed by Whistler. He enlists the aid of Leena (Helper) in this quest. Unfortunately he is too late and finds that Spencer's ancestor has been



turned into a trancer and the result of this is that the father figure of Spencer pays for Deth's mistake with his life (Father Atonement). Also at this point Deth, for the first time, uses his long second watch. (When the button on this watch is pressed, one second is stretched to ten for the person who is wearing it). So rather than steal a magical elixir he uses a 'magical' watch which has been 'stolen' from the future. He goes back to Chinatown to decide on his next move but against his will is brought back to Angel City (Return). Here it is necessary to insert an additional section as Deth returns once more to Los Angeles and uses another identical 'magical' watch to help him rescue his anima-guide Leena. After his success he remains in Los Angeles.<sup>II</sup>

From this analysis it would seem that the pattern of the hero quest in Trancers is almost identical to the expected mythological hero-quest pattern. That such strong mythological patterns occur in films is not surprising when the psychological mode of analysis is adopted. In fact given the framework of analytical psychology it can be regarded as a sign that these ancient mythological structures are alive and well in this film.

Now that the mythological context for the central quest motif has been established it is possible to commence the analysis of the auxiliary myth themes for Trancers.

### Height and Depth

Before embarking on a discussion of the psychological and mythological importance of height and depth it is important to be clear about the role that this concept plays within Trancers.

The cosmology of Trancers is such that the city of Los Angeles is depicted as being 'down the line' and the future Angel City is 'up the line'. There are several important concepts here. First it seems as though there is a physical tie between the two cities - the line. This line is a line of time and bonds together two separate time scales into the one geographical location.<sup>III</sup> This line seems to operate as a type of Axis mundi which runs through the two cities. Jack Deth descends from Angel City, down the line into the world of Los Angeles, or rather he descends into the underworld to hunt for Whistler. Deth is constantly on a downward journey, first he goes down the line, and then nearly all his movements in Los Angeles are depicted as being downward. For example, in the motor-bike chase sequence he is forced deeper into the underworld while Leena remains on the surface, and again at the end of the film he glides down a wire to rescue the falling Leena. Jack Deth is heroically descending not only into the depths of his own unconscious, but also into the archetypal objective psyche and this goes some way to explaining the collected and archetypal patterns that provide the structure for Trancers.

While Jung constantly stresses the importance of the unconscious, he is also keen to acknowledge its dangers, and these are dangers that Deth is only too aware of:

'For where is a height without depth, and how can there be light that throws no shadow? There is no good that is not opposed by evil... What is down below is not just an excuse for more pleasure, but something we fear because it demands to play its part in the life of the more conscious and more complete man'.<sup>1</sup>

As mentioned there is a way in which the upper world, and the underworld, are linked and this is a common mythological theme. For example the Egyptians thought of the sky as supported by the father whose vitality and phallus

---

<sup>1</sup> C. W. 10: 271

becomes the Axis mundi on which the world turns (c.f. illustrations below). In the Polynesian creation myth, again the world is shaped by the people who inhabit it, and a link is thereby made between the heavens and the earth. In India Mount Meru is believed to stand in the middle of the world, and in Palestine Mount Tabor is again thought to stand at the world's centre and bond heaven and earth. (The word Tabor is derived from Tabbur meaning navel or more correctly world navel - Omphalos) so while the underworld may be dangerous there is a way in which we are bonded to it and cannot escape. Indeed each of us carries the underworld in our own psyches and these myths serve to illustrate that the Imago mundi is constructed around an Axis mundi which is our ego centre. There is also a sense in which Jack Deth's underworld is also ours, as all humanity shares the principal, archetypal core of the objective psyche.

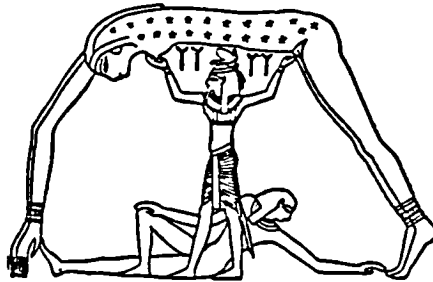

The Separation of Sky and Earth in the Egyptian Cosmology

From The Hero With A Thousand Faces, (New York, 1949)

This edition, (London, 1968): p283

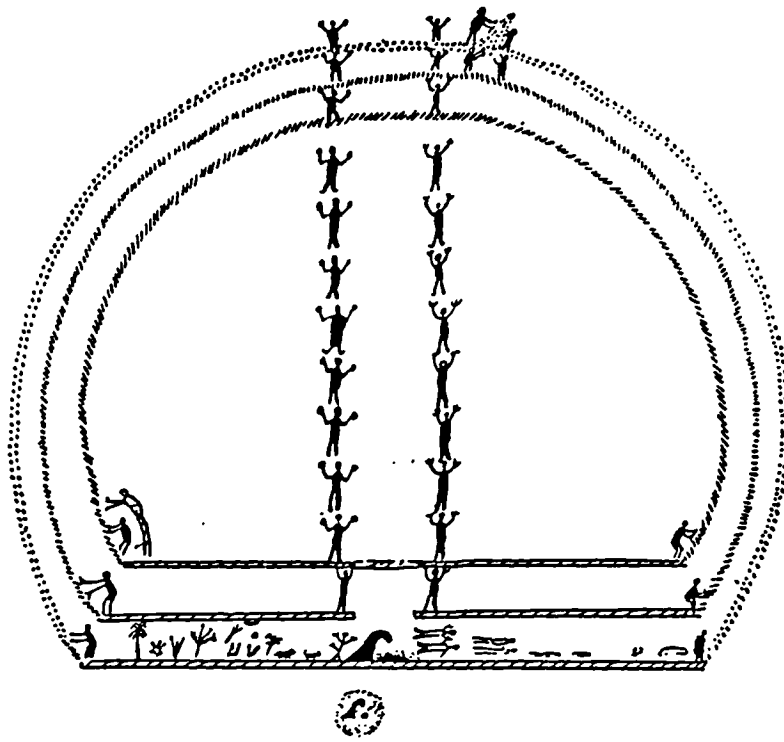

The People Shape the World in the Polynesian Creation Myth  
Ibid: p275

While it is desirable for the clarity of this analysis to separate the cosmology of Trancers into two parts, the upper Angel City and the lower Los Angeles, there is a sense in which these two places are synonymous.

If the principle of Enantiodromia is applied, then it becomes clear that it is no longer enough to create a mythological dualism of time and place, because these opposites of above and below, inner and outer, run into each other. Angel City and Los Angeles are effectively the same place, the inner world of the unconscious is the same as the outer world of the senses. As Hillman notes,

'The simultaneity of the underworld with the daily world is imaged by Hades coinciding indistinguishably with Zeus, or identical with Zeus Chthonios. The brotherhood of Zeus and Hades says that the upper and lower worlds are the same; only the perspectives differ. There is only one and the same universe, coexistent and synchronous, but one brother's view sees it from above and through the light, the other from below and into its darkness'.<sup>1</sup>

---

<sup>1</sup> Hillman, (1979): p30 :

Jack Deth can visit Los Angeles either as a diver exploring the sunken ruins of the Lost City, or he can go down the line and explore as a detective in 1984. For him the two places are one, what has changed is not the city but his perspective on Los Angeles. This becomes evident in the motor-bike chase sequence. Here he has to leave Leena, his guide, who asks him, 'Do you know your way back to Chinatown?', to which he replies, 'Sure, I used to swim through here'. Deth knows the plan of the city but his perspective on it is different.

This is one of the psychological 'truths' which Jack Deth has to learn, that while he is in Los Angeles he is both an 'outsider' and an 'insider'. It is one of the film's hidden messages that to progress with individuation, one must go deep into the underworld, but this can only be achieved by expanding conscious awareness, for it is through the conscious that the unconscious communicates.

'Our familiar term depth psychology says quite directly: to study the soul, we must go deep, and when we go deep, soul becomes involved. The logos of the soul, psychology, implies the act of travelling the soul's labyrinth in which we can never go deep enough'.<sup>1</sup>

Or in other words, to understand the psyche at deepest level, for a real depth psychology, one must go into the underworld, and in his quest for the shadow figure of Whistler, this is what Jack Deth does.

### Life and Death

In Trancers there are two principal death themes. Within one theme death is final and absolute, but in the other theme death becomes part of life, and is a renewing event resulting in rebirth. As far back as Socrates death

---

<sup>1</sup> Hillman, (1979): p25

has been polarised in these two ways, either it is final, or there is life after death.

'Death is one of two things. Either it is annihilation, and the dead have no consciousness of anything; or, as we are told, it is really a change: a migration of the soul from one place to another'.<sup>1</sup>

The theme that death is final belongs to Whistler, who represents death in its most negative aspects. Through his psychic power he invades the lives of weak people and becomes their master, part of their old self dies and they are left with a body which is empty, as Deth said at the beginning of the film, they are dead, but 'not dead enough'.

The theme of life/death is of course one in which the whole detective film genre is immersed. In the Film Noir Crossfire (Dir. E. Dmytryk, RKO, 1947), not only is the life/death theme evident but the film also has a similar way of depicting and mythologising death. For example the film opens with a sequence showing the shadows of two men fighting, and it is soon disclosed that this is the murder around which the narrative is to centre. In the terms of analytical psychology the symbolic interpretation is clear. Here extraverted ego-consciousness wrestles with and destroys the shadow, and, as in Trancers, the shadow is equated with death.

It is interesting to note that in this film Samuels, the murder victim, is killed because he is a Jew. However in the original novel The Brick Fox Hole, written by Richard Brooks, Samuels is killed because he is a homosexual. Thus the shadow in the novel is tainted with the odour of the anima, unfortunately this is lost in the screen adaptation thereby weakening the psychological structure of the film, although the shadow as projected onto a Jew remains a strong psychological motif.

---

<sup>1</sup> Plato, The Last Days of Socrates: The Apology, Trans. Tredennick, (London, 1954): p 41

Regarding the theme of life/death and the shadow, at the end of Crossfire the detective refers to the murderer Montgomery, whom he has just shot, saying 'He was dead for a long time, he just didn't know it'. An echo of this is heard in Jack Deth's line about trancers, they were 'dead, but not dead enough'. Both Crossfire and Trancers share a portrayal of the shadow in which once the shadow possesses ego-consciousness the entire self is destroyed. Both these films illustrate the dangers of possession by unconscious forces and hence the importance of properly assimilating them into ego-consciousness.

To return specifically to Trancers, once one of the 'half dead' trancers finally becomes useless to Whistler, or when they are 'singed', then their bodies glow red and they disappear leaving behind a black scorch mark.<sup>IV</sup> For the disciples of Whistler there seems to be little hope. First they lose their spirit, their capacity for free will, although they may have already begun to lose this before encountering Whistler<sup>V</sup> and after this they lose their bodies which are burnt in what is an almost sacrificial way. However in mythology death and sacrifice do not have to be destructive, and it is now appropriate to progress to this other theme of death in Trancers.

In his writings Jung is anxious to stress that preparation for death is an integral part of life. Clearly Whistler's victims are not given this chance to prepare for their deaths, as they are possessed by Whistler without their assent. In writing about the preparation for death Jung has said, 'Like a projectile flying to its goal, life ends in death. Even its ascent and its zenith are only steps and means to this goal'.<sup>1</sup> And, 'From the middle of life onward, only he remains vitally alive who is ready to die with life'.<sup>2</sup>

---

<sup>1</sup> C. W. 8: 803

<sup>2</sup> C. W. 8: 800

and finally, 'Death is psychologically as important as birth and, like it, is an integral part of life'.<sup>1</sup> All of these quotes stress the importance of preparing through life for death, and indeed this must be regarded as part of the hero's role and hence part of Jack Deth's role.

Here the most important concept to be understood is that death does not ipso facto bring death, it may bring life. The idea that death can bring life is found in the Christian tradition. Here in the ritual mythology of baptism the old self dies so that a new person can be reborn. The new person is recreated or reborn in Christ, as the apostle Paul writes in Romans,

'Or don't you know that all of us who were baptised into Christ Jesus were baptised into his death? We were therefore buried with him through baptism into death in order that, just as Christ was raised from the dead through the glory of the Father, we too may live a new life'.<sup>2</sup>

Again, within the Christian tradition there is the understanding that Christ died and descended into hell so that the people of the world who were saved by this action would not have to descend there themselves.<sup>VI</sup> The famous theologian Luther has commented that, 'Christ's resurrection is our resurrection'.<sup>3</sup> In all these quotations there is the clear understanding that because a hero (saviour) has undergone a trial, humanity does not have to undergo that test. In other words, the hero descends into the underworld on the behalf of humanity, and from this he brings the world salvation.

This can be directly applied to the figure of Jack Deth who as an archetypal hero experiences individuation for himself, but also for consciousness generally. He is a Heilbringer, a bringer of salvation. However like all heroes

---

<sup>1</sup> C. W. 13: 68

<sup>2</sup> The Bible, Romans, New International Version, (London, 1979): 6: 3-4

<sup>3</sup> Luther, M., Commentaries on I Corinthians 15, (St Louis, 1973): 28: p202



Deth must pay the price of his role as a saviour in two ways; first by dying to his old Self and being reborn by the incestuous relationship, and secondly he must sacrifice himself. He decides to destroy the shadow-criminal of Whistler and in so doing he chooses to stay in Los Angeles, because he only has one phial of antidote to the time drug. He uses this to send Whistler up the line where his body has already been destroyed, and in symbolic terms, this is sacrifice of himself to destroy Whistler. Deth leaves behind the world of consciousness to live in the underworld.

The myth of the hero sacrificing himself can be made clearer by reference to the Hindu Vedic creation myth of the 'Cosmic Sacrifice'. The God, Purusha, is at once the supreme being, the cosmos and man, and as such his primordial sacrifice is the very act of creation. Purusha's self-immolation becomes a prototype and from this in the Vedic tradition, all sacrifices are repetitions of this initial creative act.

11. When they divided Purusha how many portions did they make?  
What do they call his mouth, his arms? What do they call  
his thighs and feet?
12. The Brahmas was his mouth, of both his arms was the Rajanya  
made.  
His thighs became the Vishya, from his feet the Shudra was  
produced.
13. The moon was gendered from his mind, and from his eye the  
sun had birth.  
Indra and Agni from his mouth were born, and Vaya from his  
breath...
16. Gods, sacrificing, sacrificed the victim; these were the  
earliest holy ordinances.

The mighty ones attained the height of heaven, there where  
the Sedhyas, gods of old, are dwelling'.<sup>1</sup>

This myth aptly illustrates how death can be creative and how it can bring new life. This is the type of death that Jack Deth symbolises; it is not a destructive death but a creative one. In psychological terms it is not so much that Whistler has been killed, it is more that he has been transcended and the shadow can now be assimilated.

### Body and Spirit

In Trancers there exists a unity between the concepts of body and spirit. In other words in this mythology there is an indication of the interdependence of body and spirit. However, at this stage it is important to elucidate two meanings of the term 'spirit'. First there is the spirit which means a person's consciousness and latent personality - it is this spirit which Trancers primarily deals with. Associated with this is the second type of spirit; this Spirit refers to the eternal Self or the soul, and represents the spiritual perfection of mankind. In the terms of analytical psychology this equates with a finished individuation process. Of course the distinction between these two types of spirit is not clearly defined, as perfection of the bodily spirit may result in a higher level of spiritual perfection, as Blake comments,

'Man has no Body distinct from his Soul; for that Body is a portion of Soul discerned by the five senses, the chief inlets of Soul in this age'.<sup>2</sup>

---

<sup>1</sup> Rig Veda, Hymns of the Rig Veda IV, Translated Griffith, R. T. H., (Benares, 1892): p289-293 X, 90

<sup>2</sup> Blake, W., 'The Marriage of Heaven and Hell. The Augment.' The Complete Writings of William Blake, editor Keynes, G., (London, 1966): Plate 4, Lines 10-12

However in Trancers there exists a higher level of dualism than this, for Jack Deth's body may remain intact whilst his consciousness is sent to Los Angeles. Also, Philip Dethton's body is inhabited by the spirit of Jack Deth with no apparent ill effects to either party. (There is a gap in the film's information at this point because the viewer never gets to know how Dethton feels about being taken out of his body, and Deth is certainly annoyed at the way in which he is shuttled up and down the line). However the real problems occur when the body is inhabited by an evil force, that is the mind control of Whistler. What occurs is not a simple exchange of bodies and spirits, but a spiritual attack in which Whistler attempts to possess the entire somatic unity of an individual. The attack will only succeed on someone who is weak, 'squids' as Deth calls them, and this is a mythological example of a psychological truth; that the shadow possesses those with an under-developed ego-consciousness.

At this point it is important to further investigate exactly what a trancer is, as this brings together some of the themes in the film. As Jack comments, trancers are people who are half dead, they have not completely died, although they are apparently under Whistler's psychic power. Trancers seem very much in the model of Zombies who traditionally are people which are made to work for someone; for example, a farmer may approach a witch-doctor to activate them. The trancers also look like the traditional film image of the zombie. They are clearly human in shape, and yet they are grotesquely disfigured as their bodies swell up and their skin turns yellow. The film never shows someone becoming tranced but what is noticeable is that once they have become a trancer they seem to lose all sense of self-identity and become functionaries.

Curiously what all those who have become trancers share is a uniform. For example; the waitress, the policeman, the Santa Claus, the suntan man. In

psychological terms what they call exhibit is an excessive identification with the persona that their uniform indicates, so the two trancer cops in the warehouse when challenged by Deth reply, 'The Lieutenant (Whistler) is the finest man on the force. I've pledged my life to him', and the first thing that Cris Lavery, the suntan athlete, comments on is Jack's suntan, which forms part of Lavery's persona. The trancers in the film are not really characters at all but functionaries, and by identifying with their personas they have made themselves susceptible to Whistler's power. All that Whistler has to do is take the logical step, and exploit this weakness. What puts Deth at risk is that he seems to place a similar excessive reliance on his persona.

Strangely it is Deth who appears to activate the trancers. For example the waitress trancer is serving someone until he arrives, when she is activated and tries to kill him. The important thing is that it is impossible to tell who is, or is not, a trancer, until they meet Deth and it is almost as though he is a chemical, rather than a secret, agent. He seems to represent a catalyst which activates the latent trancer, and yet he does not seem to realise this as he still administers T.S.E's (trancer suspect evaluations) to non-tranced people.

This power to activate the trancers gives Deth a closeness or affinity to them. Like him they hold on to a persona but also like Whistler they represent the inner shadow. In some ways they form a midpoint between Deth and Whistler; on the outside they carry their personas and like him are physically strong, yet on the inside they hide the invisible shadow Whistler, and here they are weak. So in the scene at the warehouse when he is faced with a trancer cop and says, 'I'm just a cop like you', the trancer tries to do what the persona would do, his duty. However they experience a little

difficulty and he urges him to fight the power of Whistler, but in the end the cop is unable to escape this power.

It is important to note that there is more than one set of trancers in the film. For example, at the night club where Deth goes to dance with Leena he encounters a group of punks and describes them as being 'Like a bunch of trancers'. To him they are trancer-like because they don't seem to have any control over their bodies and, like the trancers controlled by Whistler, he 'activates' the trancer-punks and ends up fighting them. It is Deth who brings this violent destructive response from them. The other set of trancers are the drunks at the warehouse who are in an alcoholic trance and from these 'trancers' he calls forth Hap Ashby, the person whom he and Leena are searching for.

In contrast to the tranced characters are the characters in the film who cannot be tranced, most notably Hap and Leena. Both Hap and Leena are strong characters with a sense of purpose. They do not have the type of excessive persona identification which puts the other characters at risk, and both of them have a mission. For Hap, one of his descendants is to become a leader in the twenty-third century, and Leena has a vocation to guide and protect Deth. It is the strength of her devotion to him that protects her against Whistler's attempted trancing, and causes Deth to comment, 'The girl won't trance Whistler, she's too strong'.

Hap and Leena have strong spirits and this prevents Whistler from taking over their bodies; one critical interpretation of this is that the film is saying it is important to have a sense of purpose and to be in control of yourself. Trancers seems to make heroes out of those with a singleness of purpose, and these are the qualities that Jack Deth exhibits. VII

To bring this section to a close it will prove helpful to weave together some of its diverse threads, but to do so within the mythological framework of body and spirit, which dualism is personified by the trancers.

The dualism of body and spirit is evident in Christianity, as is the famous saying of Jesus, 'Watch and pray so that you will not fall into temptation. The spirit is willing, but the body is weak'.<sup>1</sup> This dualistic theory enters a highly mystical phase when it is developed by the apostle Paul who believed in a perishable mortal body but an eternal spirit. However it is not an individual's own spirit that lives but the spirit of the hero Christ, the first person of the trinitarian Godhead.

'But if Christ is in you, your body is dead because of sin, yet your spirit is alive because of righteousness. And if the Spirit of him who raised Jesus from the dead is living in you, he who raised Christ from the dead will also give life to your mortal bodies through his Spirit, who lives in you'.<sup>2</sup>

What Paul is stating here is typical of the hero sacrifice myth, that through the hero's death and rebirth (resurrection), all believers may experience their own rebirth. In the terms of analytical psychology this is mythological evidence of the insight that a hero's individuation aids the whole culture in its individuation process.<sup>VIII</sup>

### Summary

Before starting Chapter Ten, it may prove useful to provide a summary of the main points in this chapter.

---

<sup>1</sup> The Bible, Matthew, 26: 41

<sup>2</sup> The Bible, Romans, 8: 10-11

- 1) Opposites tend to run into each other. For example in the case of rebirth, death becomes life, this tendency is called Enantiodromia.
- 2) The central quest myth of Trancers is the hero detective's quest. This physical outward quest is a metaphor for his inner quest which is individuation.
- 3) The secondary or auxiliary myth themes of height/depth, life/death and body/spirit are united and find expression in the central myth theme.
- 4) The hero-detective Deth's quest for individuation indicates a cultural quest for individuation, and it both reflects and aids the process.

CHAPTER NINE NOTES

- I. c.f. Chapter Two, p54, Note I
- II. It is interesting to note that Empire Entertainment, the umbrella organisation for all director Charles Band's activities, is planning to produce a sequel to Trancers called The Return of Jack Deth. From the quest model that has been created, certain predictions about the general plot structure of the film can be attempted. First, Jack Deth must be re-called across the threshold into the twenty-third century. Here, once again, his help will be required to maintain the civilisation of Angel City. To assist him in this quest he will be provided with certain magical items and will enlist the aid of at least one helper.

In terms of the individuation process it would be expected that Deth will no longer be combating his shadow nor maybe even his anima, and the appearance of a 'wise old man' figure is anticipated. Of course this is pure conjecture and just represents a development of the individuation process and one more circuit of the quest cycle. However it would seem a vindication of this type of psychological model if the film does conform to these expectations.

- III. A detailed discussion of the symbolism of time will occur in the section on Mythology and Mythologem, Chapter Ten, p276-281
- IV. c.f. Appendix II, b and f
- V. c.f. p267
- VI. c.f. Tertullian, De Anima 55, Ante-Nicene Christian Library, editors Roberts, A. & Donaldson, J., (Edinburgh, 1870).
- VII. This is a highly contemporary American myth and it is only necessary to look as far as the Rambo series of films to find this myth in an extreme version.
- VIII. For a complete analysis of Christ's individuation, c.f. C. W. 11: 296-448



Chapter Ten

Mythology and Mythologem

'It seems that a myth itself, as well as the symbols it brings into play, never quite disappears from the present world of the psyche; it only changes its aspect and disguises its operations'.

M. Eliade

Myths, Dreams and Mysteries: The Encounter between Contemporary  
Faiths and Archaic Reality

INTRODUCTION

This section is concerned with the symbols that are liberated in Trancers and, while acknowledging the range of meanings a symbol may contain, it is hoped to show that these symbols form part of a cohesive mythological unity. Due to the diversity of meaning contained within a symbol,<sup>I</sup> and because of its ultimately unknowable nature, it is important to stress that the following interpretations of the symbols in Trancers represent only one of many possible perspectives. The perspective adopted by this chapter is the same as that of the film, namely, the underworld. Through the underworld, and within the context of the detective mythology, the various and apparently contradictory (Enantiodromian) readings of the symbols will be explored. Hillman has commented on the ambiguity of dream images and his remarks remain valid for symbols in films, which clearly have affinities with dream symbols.<sup>II</sup>

=

'The ambiguity of dreams lies in their multiplicity of meanings, their inner polytheism, the fact that they have in each scene, figure, image "an inherent tension of opposites," as Jung would say. The tension is more than that, however, it is the tension of multiple likenesses, endless possibilities, for the dream is soul itself, and soul, said Heraclitus, is endless'.<sup>1</sup>

With this warning in mind it is now proposed to start the analysis of the symbols, seeing each symbol from within a mythological and underworld perspective and placed firmly within the mythology of Trancers.

---

<sup>1</sup> Hillman, J., The Dream and the Underworld, (New York, 1979): p126

SYMBOLIC TIME

Before embarking on an examination of the symbolic role of time in Trancers it is important to provide a very brief context to the process of time measurement, and also to provide a psychological perspective within which to think about time.

One of the important factors about time perception is that it is culturally dependent. Each culture devises a system of time measurement, or perception which is best suited to its specific needs, and the most striking thing about the present Western system is that it is an even and cyclical system. This psychological perception of time as an even flowing, circular, current is something which is fairly recent in Western thought. As Thomas comments,

'But, essentially, these beliefs about the unevenness of time were the natural product of a society which was fundamentally agrarian in character, and relatively primitive in its technology... These changes (in technology) meant that the Newtonian conception of time as continuously flowing and equable in quality was not just intellectually valid; it had also become socially acceptable'.<sup>1</sup>

For many, and for Jung, the Newtonian concept of time was neither intellectually valid nor socially acceptable. This concept of the objective psyche places archetypes as essentially outside time, because they are independent universal patterns, both governing past developments, and predicting or preparing future ones. As Jung comments,

'Anything psychic is Janus faced; it looks both backwards and forwards. Because it is evolving, it is also preparing the future. Were this not so, intentions, aims, plans, calculations, predictions and premonitions would be psychological impossibilities'.<sup>2</sup>

---

<sup>1</sup> Thomas, K., Religion and the Decline of Magic, (London, 1971). This edition, (London, 1984): p744-745

<sup>2</sup> C. W. 6: 717f

Or more simply, 'Everything psychic is pregnant with the future'.<sup>1</sup> So Jung's concept of time is not bound by a materialistic linear perception, rather he adopts a mythological approach in which time is at once present, future, and past. As Blake puts it,

'To see a world in a grain of sand  
And heaven in a wild flower  
Hold infinity in the palm of your hand  
And eternity in an hour'.<sup>2</sup>

The first and most obvious point at which this psychology of time intersects with Trancers is with the incest theme. It will be remembered that the hero-detective Jack Deth apparently attempts to commit incest, in so much as he tries to have sex with Leena, who may be one of his distant female ancestors. This incest theme, as has been demonstrated, is universal to the hero myth, and results in the hero's rebirth and immortality. If the hero myth and the time symbol, (that is the view of time as means of escaping the present moment), are connected, then the reason for the hero's eternal values becomes clear. In the following quote, Jung is talking about the physical relationship between daughter and mother, but his remarks apply equally well to the situation in Trancers in which Deth attempts to create his own ancestral heritage and children,

'The psyche pre-existent to consciousness (e.g., in the child) participates in the maternal psyche on the one hand, while on the other it reaches across to the daughter psyche... This participation and intermingling give rise to that peculiar uncertainty as regards time: a woman lives earlier as a mother, later as a daughter. The conscious experience of these ties produces the feeling that her life is spread out over generations - the first step towards the immediate experience and conviction of being outside time, which brings with it a feeling of immortality'.<sup>3</sup>

---

<sup>1</sup> C. W. 14: 53

<sup>2</sup> Blake, W., Auguries of Innocence, lines 1-4, 1803

<sup>3</sup> C. W. 9,I: 316

Thus the hero's incest theme, as it is represented in Trancers, is an extension of a normal psychological and physiological theme. The archetype of the hero has found a cultural expression in the film, and yet precisely because the theme is universal, its message is both highly individual and personal. On a cultural scale the hero can once again be regarded as a representation of a collective ego-consciousness who, on a culture's behalf, seeks to live the mythological life of individuation.

Within Trancers there are two further time themes. First it is interesting to note that upper and outer worlds are 'out of sync'. That is to say that time and date do not correspond exactly, so when Deth leaves Angel City for the first time it is July, and as he arrives in Los Angeles it is Christmas Eve. Another indication of this non linearity of time occurs when Deth is attempting to have sex with Leena, here he is taken out of his ancestor's borrowed body for only five minutes, but when he returns he discovers, to his chagrin, that apparently at least half an hour has passed. So while the two worlds are connected by what is almost an Axis universalis, time in the upper world and in the underworld seem to move at different speeds. This apparent dichotomy of time scales will be explored below, but before this it is important to mention another way in which time is treated in Trancers.

One of the objects that Jack Deth brings with him into Los Angeles is a 'long second watch'. It will be remembered that when the button on the watch is depressed, then one second is stretched to ten for the person who is wearing it. This gadget is useful to him on two occasions, first when Whistler shoots at Leena and Deth as they are coming out of a suntan parlour, and secondly at the end of the film where Whistler throws Leena over a building. On both occasions he activates the long second and is able to move Leena out of the bullet's path<sup>III</sup> or catch her as she falls. The way

in which the film depicts this long second is by having two slow motion sequences, thus the viewer is treated to the same view of the event as Deth and identification with the hero figure is increased. (With reference to the first of these two occasions it is interesting to note that Robbe-Grillet wrote a detective novel, 'The Erasers', which takes place in the moment between the firing of the murderer's gun and the bullet's arrival in its victim. The detective's entire investigation takes place in this moment and, perhaps, some reference is being made to this novel).

The reasons for these apparent discrepancies in time scale, become clear when reference is made to the mythological representation of sacred and profane time. Here it may be helpful to refer back to Thomas' point about the relationship between representations of time and technology. The point is that today for Western man it is no longer enough to rely on the linear Newtonian concept of time that Thomson delineates, because the perceptual sphere of Western man has increased to include the discoveries of Einstein and quantum physics. These discoveries have shown that time is not fixed, but is dependent upon other factors, for example speed and height. This new perception means that a new mythology has been created, or rather an old mythology has been recreated, for the certainty of science has been eroded by its own theoretical speculations. As the scientist Heisenberg, discoverer of the now famous 'uncertainty principle' comments:

'Atoms are not THINGS. The electrons which form an atom's shell are no longer things in the sense of classical physics, things which could be unambiguously described by concepts like location, velocity, energy, size. When we get down to the atomic level, the objective world in space and time no longer exists, and the mathematical symbols of theoretical physics refer merely to possibilities, not facts'.<sup>1</sup>

---

<sup>1</sup> Heisenberg, W., Der Teil und das Ganze, (Munich, 1969): p63-64

What is important here is that even in the field of theoretical physics, time and space no longer remain fixed measurable quantities and this is the case in the world of Trancers, where not only do time scales differ but the actual experience of them also differs.

Regarding the experience of time, Eliade, the scholar of comparative religion, has made a distinction between sacred and profane time. His distinction remains valid for the so called primitive societies and for contemporary Western man, and the applicability of these notions of sacred and profane time to Trancers seems clear. Given the perspective of the underworld, and also given the 'magic' of the long second watch along with the self-contained archetypal nature of the underworld, it would seem reasonable to assert that Los Angeles time corresponds to a special type of time that can be categorised 'magico-religious time'. This is in contrast to the profane, or non mythological, time of Angel City (note again a typical Enantiodromia - it is in Angel City that time is at its most secular). As Eliade comments,

'The difficulty is not simply that magico-religious time and profane time are different in nature; it is rather more the fact that the actual experience of time as such is not always the same for primitive peoples as for modern Western man'.<sup>1</sup>

This is certainly the case in Trancers where time, specifically for Jack Deth, is different from everyone else. It is as though the numinous and magical qualities of the hero carry with them their own time scale, and as Deth appears and uses such devices as the long second so incisions are made into profane time. Further these insertions of magical or sacred time, are thematically linked together, so that it is almost possible to see them as constituting another duration with its own continuity. In mythological

---

<sup>1</sup> Eliade, M., Patterns in Comparative Religion, (New York, 1958): p388

terms Deth brings with him his own sacred time, and this is independent of time in the underworld.

The association of the hero with this type of sacred time which connects itself and constitutes its own continuum, is strikingly paralleled in the Roman Catholic Mass. Here the sacrificial death of the hero, Christ, is recreated and all Masses are linked together in and by the transubstantive moment.

'The Mass is an extramundane and extratemporal act in which Christ is sacrificed and then resurrected in the transformed substances; and this rite of his sacrificial death is not a repetition of the historical event but the original, unique, and eternal act. The experience of the Mass is therefore a participation in the transcendence of life, which overcomes all bounds of space and time. It is a moment of eternity in time'.<sup>1</sup>

So Trancers, in its use of time, seems to make certain mythological associations with the hero and sacrifice, and his incest and immortality roles. These all form part of the hero's quest mythology and reinforce his magical powers, or numinosity. Thus while there appear to be contradictions in the way in which time is represented, in fact they correspond to images of sacred and profane time. What occurs in Trancers is, in part a re-working of certain religious and magical aspects of the hero myth.

#### WATER

In Trancers there are three key moments where water occurs, and where water can be conceived of in symbolic terms. The first of these is when Jack Deth is summoned to the quest, he is called back from the ocean where he has been exploring the sunken ruins of Los Angeles. Secondly, water is used to wash

---

<sup>1</sup> C. W. 9,I: 209



Hap Ashby, and in this symbolic cleaning he is prepared for his role as a father to a future leader in the twenty-third century. Finally, water occurs at the very end of the film when Deth and Whistler fight. Here just before Whistler is sent up the line he is immersed in a fountain.<sup>IV</sup>

The possible symbolisms of water are very varied, for example there is a uterine symbolism, there is also a baptism, wisdom, the unconscious, general life force, lustration etcetera. Rather than try to account for all the possible symbolisms of water in Trancers, it is proposed to let the underworld perspective dominate, because all these events are associated with Deth and his downward and inner journey. The association that will be concentrated upon is therefore the way in which water is connected to the theme of death, and bearing in mind the principle of Enantiodromia this will also involve thinking about life, or rebirth. As Heraclitus has commented, 'To souls, it is death to become water...'<sup>1</sup> or in another translation, 'It is delight, or rather death, to souls to become wet...'<sup>2</sup>

If Heraclitus' statement concerning the inter-relationship of water and death is connected with the well known alchemical saying to 'perform no operation until all has become water', then it becomes clear that the process of individuation must first start with death to the old Self. Quite literally, the old Self is washed away.

This applies directly to Jack Deth's underwater investigations of the city where the contagious nature of the underworld gradually infects him, until he has no option but to truly explore its depths. In this act his ego-consciousness is washed away to reveal the unconscious aspects of his psyche.

---

<sup>1</sup> Heraclitus, Frg. 36. Translated Marcovitch

<sup>2</sup> Heraclitus, Frg. 77. Translated Freeman

With Ashby the situation is similar, though he is not so much involved with the lustration symbolism of water. It is quite simply that to prepare himself for the death of his old tramp-persona and the arrival of the new persona of respectable fatherhood he must be symbolically initiated by water. He is beginning a hereditary and transforming chain and if his soul is to live on in the child who is destined to become one of the leaders in the twenty-third century, then he must 'delight' in the death of the old Self by water. So it begins to seem as though there is a cycle at work where the constant process of life and death are renewed, by and in water, in an uroboric fashion. In the third example Whistler is prepared for his death, by Deth, who immerses him in water, it is only a few minutes after this that Whistler is sent up the line, where his body has already been destroyed.

As initiation through, or into, the water brings with it a new life in which the old self has been revitalised, interpreters of dreams and symbols have identified water with rebirth, emotions, affects and invasions,<sup>V</sup> or with feelings. However, the emotions are often, as in the case of Ashby and Whistler, located in ego-consciousness and the water serves to wash away these feelings and to reveal a more universal pattern. What may be death to one part of the personality the persona, may bring life to another; the Self. Thus the constant process of dying to self (ego-consciousness) in an attempt to establish the archetype of Self, is started.

Regarding Whistler's future, the film is deliberately ambiguous. Deth has sent Whistler's consciousness up the line to Angel City where there is no body for him to inhabit. Does this mean that Whistler simply ceases to exist? Or maybe the washing of Whistler in the fountain, and the presence of the Buddha statue indicates a type of the mythological rebirth theme?<sup>VI</sup> At this point it is more helpful to look towards Jack Deth than Whistler,

because for him the immersion of Whistler is a ritualised enactment of his desire to 'wash away' his shadow. This washing sequence seems to foretell the demise of Whistler, it occurs just before he is sent up the line, but yet it also shows Deth's desire to assimilate the shadow. He has removed his persona-raincoat, and has made a commitment to Leena by again using his long second watch to rescue her. In symbolic terms he has made a commitment to move past the shadow phase through to the anima stage of individuation.

This moving, flowing, aqueous nature of Deth is revealed in the imagery of the film, for example when he is shown emerging from the waters covering Angel City, and when he washes both Hap and Whistler initiating them both into new roles. Deth is himself changing. As he flows inward on his quest so the outer nature, the persona dies; and as a new stage of individuation is reached so a new person is born.

A parallel to this, which uses the same imagery as the film, can be found in Heraclitus. Heraclitus regards death in water as a way of bringing forth new life, and the previously quoted fragment thirty-six (Freeman) continues: 'To souls it is death to become water; to water, it is death to become earth. From earth comes water, and from water, soul'.<sup>1</sup>

Thus an uroboric movement or flow is revealed. The individuation process demands a movement like the flow of water, for it is 'death to become earth'. To remain in a fixed static relationship to earth is death in a real sense, it results in a stagnation of what should be soul making, individuation aiding waters. Jack Deth knows this, and that is why he spends time in Angel

---

<sup>1</sup> Heraclitus, Frg. 36. Translated, Marcovitch, M.

City swimming through the sunken ruins, immersing himself in the water which has come from the earth, as that which was once earth is now quite literally water. Deth also ensures that others are immersed in water, notably Whistler and Ashby. What is clear is that in Trancers there is an association between Deth and water. It is through this contact that new life is created, and individuation is aided.

### FOOD

Food in Trancers is seen on only three occasions but on at least two of these times it has a symbolic function, in that the food symbolises a mythological and psychological process which the film only indirectly expresses. The symbol is not only unifying opposites but also provides the Tertiam non datur.<sup>VII</sup>

The first time food appears is at the start of the film. Here Deth asks a waitress, who later turns out to be a trancer, for some coffee, to which she replies, 'What the real stuff? That's gonna cost you mister!'. Deth also requests real milk and not a soya substitute. Before analysing this it is useful to look at another meal as this helps to provide the context for the symbolic food images. On this occasion the food is brought to Jack Deth by Leena, who brings the food to the apartment where they are staying. The food is a Chinese take-away and is charged to Philip Dethton's account. Deth comments, 'We'll call it my inheritance' and again expresses surprise at having real beef to eat, 'From cows?'. At first there is an almost sacrificial atmosphere to the eating, characterised by long silences and the small quantities of food eaten, for someone who has not eaten all day Deth takes remarkably little interest in the food. The quasi-religious ambience continues until Leena pretends to have found a message from Whistler inside

a fortune cookie. This joke swiftly changes the mood and the couple move to the disco which according to Deth is 'full of trancers'.

Again it is proposed to locate the interpretation of the symbolism of these food sequences firmly in the underworld mythological context of Trancers. The analytical psychologist, Hillman, has the following comment to make on the association between food and the underworld,

'Such foods and such meals may then be understood as referring to Hades, "the hospitable," the hidden host at life's banquet. Then these ritual communions may open the way into an easier fellowship with one's "dead persons." These are usually experienced as family influences from the past, as the un-lived life, the unfulfilled expectations of the ancestors that one carries unwittingly'.<sup>1</sup>

This certainly seems to directly apply to the second sequence where Deth is fed by one of his ancestors who is at the same time a projection of the positive qualities of his anima. In the first food sequence he is fed by a shadow projection and Deth, who is not yet psychologically able to cope with this situation, is forced to singe the trancer. What is significant is that on both occasions it is women who provide him with 'real' food, either real coffee or real beef.

This symbolic act seems to suggest that the psyche needs to be fed.<sup>VIII</sup> If Deth is to succeed on his quest then he must receive nourishment, but this nourishment is not so much actual as symbolic, for he never drinks the coffee and only eats a small portion of the beef. Also both of these food sequences precede dramatic psychic events, and this helps to strengthen this reading. In one instance Deth discovers the shadow projection (trancer) and in the other he is forcibly sent up the line.

---

<sup>1</sup> Hillman, 1979: p172

The idea that the psyche needs feeding, that is that the psyche needs inner food just as the body needs outer food, is a common mythological motif. For example there is the widespread practice of leaving food and cooking utensils in the graves of the dead. It also occurs in the annual Greek ceremony (Anthestia) of feeding the souls (Keres) that have returned from the underworld to their former living place, and indeed on Halloween as a 'treat' we give food to masked children in the hope that in return these puer like shades will not 'trick' us. All these examples indicate the psychological truth that if individuation is to proceed, if a psychologically healthy life is to be led, then the body needs the food of inner images. As Hillman puts it, '...we are shown that the body draws upon the soul for its nourishment. The life of the body needs the soul stuff of images'.<sup>1 IX</sup>

In these, and other mythological offerings of food, while the meat, the coffee or whatever might be offered is natural or 'real', what nourishes is not literal, but sacrificial and metaphorical. Eating becomes a moment in which change occurs, a transubstantive moment, where what is the property of the outer natural world becomes changed into the property of the inner underworld. The food symbols in Trancers indicate this change, and over and above the opposites of food and starvation, carry a Tertium of sacrifice and inner growth. These symbols are a way of feeding death, of feeding the hero, and of communing with our ancestors. For Deth this ancestor is Leena, but for the viewer of the film the ancestor is the hero archetype.

---

<sup>1</sup> Hillman, 1979: p174

THE SYMBOLISM OF BLUE AND FOOD

As can be seen from the stills of Trancers, in Appendix II, the colours of blue and red dominate the lighting scheme of the film. In trying to assess the symbolic function of these colours it would have been a considerable help if their use fell into neatly organised patterns. However, in the way of symbols, they do not. These two colours are used throughout the film, to light nearly every scene, and therefore it is only possible to make general comments about the symbolic role they assume.

Perhaps the most obvious fact about the colours blue and red is that they exist at opposite ends of the visible spectrum. In fact they can be regarded as opposite colours, and as signs of everyday life they are often used in this way. For example the colour blue may sign cold, as in cold water, and its opposite red signs hot.' This opposition continues into their symbolic function where blue is associated with sky and red the ground or earth.

If these symbolic roles are seen in relationship to Trancers then blue symbolises the upper daylight world of Angel City, and red the underworld of Los Angeles (Lost Angels). Chevalier has commented on the opposition between heaven and earth.

'In the combat between heaven and earth, the colours blue and white join forces against red and green, as Christian iconography often shows, especially so in its representations of Saint George's struggle with the dragon...'<sup>1</sup>

If Chevalier is correct, then the symbolic battle between heaven and earth, or the daylight world and the underworld, can be seen enacted in the sym-

---

<sup>1</sup> Chevalier, J., and Gheerbrant, A., Dictionnaire des Symboles, (France, 1969). This edition, (France, 1973-74), Vol.I: p211. (This quotation translated by Chitnis, B., University of Stirling, Department of French).

bolic lighting schemes of Trancers. This is an agreement with the previous observations of the chapter in which the cosmology of Trancers was explored.<sup>1X</sup> It was noted that the film divides its cosmology into two sections, which are the upperworld of Angel City and the underworld of Los Angeles. These two worlds are connected by an Axis mundi, and symbolic understanding of the film's lighting reinforces this view. In this context blue symbolises the daylight world of Angel City and red the underworld of Los Angeles. Thus the film stresses the division of these two worlds through the oppositions of red and blue, yet also indicates their simultaneity by using the colours together.

So far blue has been regarded as symbolising the upper regions, or sky. However because of this, blue may also symbolise the spiritual, or inner life. (Again the principle of Enantiodromia is demonstrated as highest spirit sky and deepest inner spirit are united in the symbolism of blue). Amongst many possible interpretations of the symbol blue, Vries lists the following possibilities, '1. Heaven and heavenly gods... 2. Eternity, immensity: time and space; 3. harmony, co-operation, spirituality...'<sup>1</sup> This is in contrast to the symbolism of the colour red which is associated with '1. Fire, lightning, heat..., 2. active, creativeness, masculine (earthy), 3. blood, war'.<sup>2</sup> From this it can be observed that the oppositions in blue and red are two fold. First blue represents the spiritual and red the earthy, but blue also symbolises the feminine (blue is the colour of the Virgin Mary) and red the masculine. In Trancers this results in blue being the colour of Leena and red the colour of Deth.

---

<sup>1</sup> Vries, A Dictionary of Symbols and Imagery, (Amsterdam, 1974). This edition, (Amsterdam, 1984): p54

<sup>2</sup> Vries: p128



This symbolic understanding of the film's use of colour is in accord with the psychological functions of the characters. The first part of Jack Deth's quest is to search for his shadow and then he can progress deeper into his psyche to seek his anima, so this quest is essentially an introspective 'spiritual' journey. While Deth remains a 'red' earth character he is affected, through his contacts with Leena, by the 'blue' spiritual dimension of his searching. In contrast, to Deth, Leena belongs to the archetypal realm of the anima spirit-guide and so it seems appropriate to regard her colour as the spiritual blue.

If the oppositions within the symbols of blue and red are further exposed then it can be seen that Leena, whilst being associated with the spirit, and hence the air and sky is located in the underworld. In an opposition to this is Deth, who is associated with earth and although he is on an inner quest, he comes from the upperworld of Angel City. Again this is in accord with the principle of Enantiodromia in which the oppositions of blue/red, earth/spirit, 'run into' each other. This is imaged in the film by lighting both the upper and the underworlds with the same blue/red scheme, and the film shows in the mythology of its lighting the psychological insight that the inner and outer worlds are one. Or if it is preferred, that the detective's outer search for truth is also an inner search for individuation.

#### THE SYMBOLISM OF NAMES

There are two names in Trancers which it is proposed to treat symbolically and these belong to the hero, Jack Deth, and the criminal Whistler. Before examining the symbolism contained within these names it may prove useful to stress the importance of names as an aspect of archetypal expression. As Hillman comments,

'It is as if archetypal material chooses its own descriptive terms as one aspect of its self-expression. This would mean that "naming" is not a nominalistic activity, but realistic indeed, because the name takes us into its reality'.<sup>1</sup>

The reality behind the names in Trancers is reasonably clear, especially now that the overall character of mythological interpretation has been established. The name Whistler seems to have an aural connotation, and on one occasion Leena even calls Whistler 'Piper'. Much as the Sirens sing their song in an attempt to lure weak-minded seamen to their death, so Whistler plays a psychological tune. The aim of his 'music' is the same as the Sirens, who attempted to control the minds of sailors before eventually destroying them. Like a latter-day Pied Pier of Hamelyn, Whistler weaves his psychological melody luring the weak minded to their eventual death.

The symbolism of the name Deth should now be clear. Within this name there is both the promise of death and new life, for as a hero Deth is concerned with both death and rebirth or new life. Even the term Heros has been considered Chthonian by some scholars and they regard it as denoting the power of the lower world, and so the 'common use of the word in later Greek for a deceased person',<sup>2</sup> for someone who is quite clearly death itself. The symbolic use of names in Trancers fits neatly into the pattern that has already been established. While the names describe the psychological functions of their owners, either death or allure, they also go beyond this and point to their deeper mythological and psychological function. Whistler's name implies the potentially destructive qualities of the shadow, and Deth implies his heroic and life renewing role.

---

<sup>1</sup> Hillman, (1979): p25

<sup>2</sup> Farnell, L. R., Greek Hero Cults and Ideas of Immortality, (Oxford, 1921): p15-16

Summary

It is clear that the symbols examined in the film form part of a concealed mythological and symbolic structure. This structure supports both the central myth theme, and its auxiliary themes, while at the same time amplifying the resonances produced by this material. So far the analysis has discovered beneath the surface of the film a united, mythological, and symbolic structure which is psychological in its operation.

- 1) The ideational perspective of the underworld provides a framework for the interpretation of symbols, this perspective is both part of the film's mythology and a wider cultural mythology.
- 2) The role of time in Trancers is non linear and this gives it a point of contact with the modern mythology of 'The New Physics' and ancient agrarian myths.
- 3) The images of water are again concerned with death and the underworld, they help to establish the circular uroboric life, death, rebirth pattern which typifies the individuation process.
- 4) The feeding of the body is understood as a metaphor for the feeding of the psyche, so outer food symbolises inner spiritual food.
- 5) The colour symbolism of the film represents the unification of opposites that occurs within Trancers.
- 6) Names both label and identify the most clearly archetypal characters. Their names also give an indication of how to interpret their archetypal roles.

CHAPTER TEN NOTES

- I. c.f. Chapter Six, The Symbolic Search: p159
- II. c.f. Chapter Two, Jung's Psychology of the Unconscious: p52
- III. c.f. Appendix II, g.
- IV. c.f. Appendix II, j.
- V. c.f. Chetwynd, d T., A Dictionary for Dreamers, (London, 1974): p182-186
- VI. c.f. Appendix II, j.
- VII. The third not logically given.
- VIII. Jung has briefly referred to this idea, and interestingly he regarded going to the cinema as a type of eating, in which images are consumed and assimilated into the psyche.

'... eating the images means to assimilate, to integrate them. What you first see on the screen interests you, you watch it, and it enters your being, you are it. It is a process of psychological assimilation. Looking at the screen the spectator says to the actor: "Hodie tibi, cras mihi!" ' (Today for you, tomorrow for me).<sup>1</sup>

- IX. c.f. Chapter Nine, Archetype's Image and Mythologem: p252.

---

<sup>1</sup> Jung, C. G., Seminars on Dream Analysis, edited McGuire, W., (London, 1984): p12

Chapter Eleven

Archetypal Pattern and Mythology

'Knowledge of the universal origins builds the bridge between the lost and abandoned world of the past and the still largely inconceivable world of the future'.

Jung, The Gifted Child

INTRODUCTION

This section is concerned with uncovering the mythological parallels to the central and auxiliary myth themes. These parallels will show that what may appear to be, on the surface, a series of disparate mythological motifs or melodies, can be seen more in terms of a theme and variations. It is the purpose of this section to uncover the theme, which Trancers never directly states, and in so doing to make yet another move downwards into the psychological underworld. This thesis terms the procedure 'reinforcement' and is based around a technique advocated by Jung for understanding images that have been spontaneously 'produced' by the psyche.

'When a patient begins to feel the inescapable nature of his inner development, he may easily be overcome by a panic fear that he is slipping helplessly into some kind of madness he can no longer understand. More than once I have had to reach for a book on my shelves, bring down an old alchemist, and show my patient his terrifying fantasy in the form in which it appeared four hundred years ago. This has a calming effect, because the patient sees that he is not alone in a strange world which nobody understands, but is part of the great stream of human history, which has experienced countless times the very things that he regards as pathological proof of his craziness'.<sup>1</sup>

With recourse to two central myths or mythologems, the myth of Atlantis and the myth of the labyrinth, the psychological themes in Trancers can all be seen as part of an integral developing process. These themes, which provide the reinforcement to the other myth themes, are both present in the visual text of the film. However, their importance extends outside of this, for once these themes have been amplified, they can be seen to provide the unseen foundation upon which the mythological, and hence psychological, structure of the film is erected.

---

<sup>1</sup> C. W. 13: 325

THE MYTH OF TRANCERS AND THE MYTH OF ATLANTIS

From within the mythological perspective of this chapter there exist some points of similarity between the myth themes in Trancers and the myth of Atlantis. One of these connections, even if this is a lexical one, is between the names of the City of Lost Angels and the Lost City of Atlantis. That the film's viewer is supposed to make this mythological association, at least subliminally, is made explicit in placing the City of Lost Angels underwater. Further the establishing shot for this location<sup>I</sup> is excessively long, especially in a film that is only seventy-six minutes in length so again this stresses its importance.

Reinforcing the similarities between Atlantis and Lost Angels, the narrative of Trancers makes it clear the City of Lost Angels sank as a result of the 'great quake', and the fear that the western sea board of the United States may, someday, fall into the Pacific, is very much alive in America today. If reference is made to the City of Atlantis as described in Plato's dialogue Timaeus then it is revealed that Atlantis too, sank as the result of an earthquake.

'But at a later time there occurred portentous earthquakes and floods, and one grievous day and night befell them, when the whole body of your warriors was swallowed up by the earth, and the island of Atlantis in a like manner was swallowed by the sea and vanished'.<sup>1</sup> II

So the cities of Lost Angels and Atlantis have in common that they are both situated under water, they are both cities, they both sank as a result of an earthquake and there is also the similarity of the name. While it may be possible to make alternative mythological connections it does not seem unreasonable to suggest that the cities of Atlantis and Lost Angels belong

---

<sup>1</sup> Plato, Timaeus. Translated, Bury, Rev. R. G., (London, 1929). This edition, (London, 1966): p256:D

to the same mythic tradition, the one following in the succession of the other.

It is into the 'watery' city of Los Angeles, (which is the sunken city of Lost Angels) that Jack Deth must descend. This is not just because the city being a crime-ridden place is a suitable location for the shadow and hence the detective. Rather, to use the film's words, it is because it is a 'thriving metropolis' and is therefore alive, a living place, capable of effecting a change on both Deth and Whistler. It is in the ancient underworld of the city that Deth must face his own shadow, and in so doing save the future world of Angel City. Ostensibly his mission is to save the ancestors of the council's leaders thereby securing the future of Angel City, for if the council falls so too does the city. It is the city which represents the hope for the future, and it is also around this image of hope that Whistler's trancers gather, waiting for the council to dissolve.

Regarding the city as an image of hope, or wholeness, it is interesting to note that the plan of the City of Atlantis forms a mandala-like pattern. This is in fact a recurring theme in the design of cities and will be explored later. At this stage it is sufficient to illustrate the circular mandala-type form of this mythological city. The diagram overleaf is reconstructed from the description in Critias.

In Jung's discussions on the symbolism of the Self, he has established the convention that roundness can be regarded as a symbolic representation of the Self, and that the mandala<sup>III</sup> is one example of this type of symbolism. For Jung the spontaneous liberation of a mandala image is an attempt by the psyche to heal itself and, at least in the way that this chapter has described it, this healing means death. In this transition from the abstract



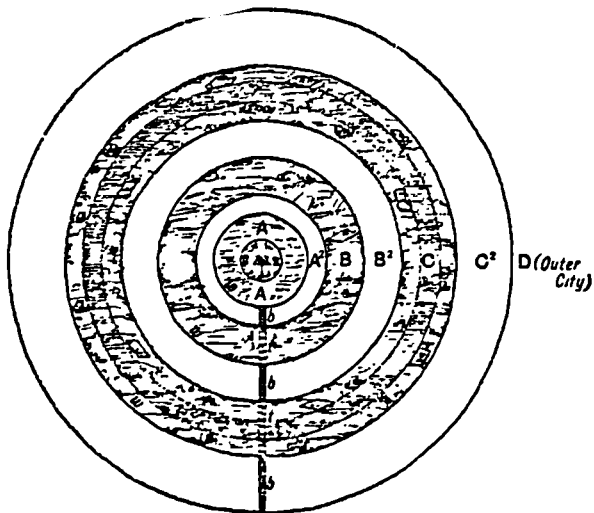

A = central island (acropolis), 5 stades in diameter, with sacred pillar, temple, altar, etc. (116 A, C ff.).  
 A² = inner belt of water, 1 stade wide.  
 B = inner belt of land, 2 stades wide, with temples, gardens, barracks, etc. (117 c).  
 B² = middle water-belt (2 stades).  
 C = outer land-belt (3 stades), with hippodrome (117 c), barracks, etc.  
 C² = outer water-belt (3 stades).  
 bb = bridges, with gates and turrets at each end, joining A B, B C, C D (116 A).  
 tt = tunnels for ships under B and C (115 d, e).  
 ww = ring-walls (4), round A, B, C, and sacrarium in A (116 A).

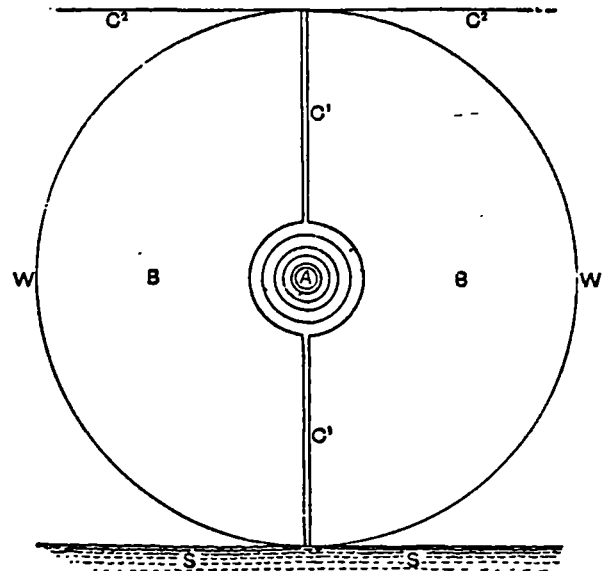

A = acropolis.  
 B = outer city.  
 W = main city-wall (50 stades from outer water-belt) (117 c, d).  
 C¹ = canal (50 stades), 115 d.  
 C² = main canal round plain (115 c, d).  
 S = sea.

#### Plan of the City of Atlantis

#### Plan of the Inner City of Atlantis

From: Plato, Translated, Bury, Rev. R. G., (London, 1929)  
 This edition, 1966: p286, p287

image of the circle to a symbol of wholeness, it is important to remember that the shadow of death is implied by the mandala. Wholeness, by its nature, embraces death.

This insight applies to the individuation process in general and specifically to Jack Deth's individuation. Within his quest for wholeness of the psyche, which is individuation, he must embrace his shadow, and also eventually his anima. For Deth, part of his individuation is accepting his own criminal, evil, shadow side, an aspect of his personality which put his wife's life at risk and threatens to do the same to Leena. If he is to

progress to the anima phase then he must accept that his wholeness does not mean perfection and the image of the city containing within it the shadow Whistler, and the underworld of crime, is a concrete form of this psychological insight.

Individuation viewed only from the naturalistic perspective of growth, implies a strengthening of the psyche. Thus the mandala becomes defensive, just as the labyrinthine walls of the city of Atlantis become defensive. Jung warns against the defensive use of mandalas and against '... artificial repetition or a deliberate imitation of such images'.<sup>1</sup> But by its nature the circle is a defensive shape and in its protective quality seemingly keeps at bay the very underworld it seeks to represent. Hillman notes that,

'As the Tibetan mandala is a meditative mode that protects the soul from capture by demons, so the Self as an all-embracing wholeness keeps the demonic nature of psychic events from getting through to the soul'.<sup>2</sup>

Association of the circle with death continues in Western symbolism, it can be observed in the ancient circular burial barrows and later circular Christian graveyards.<sup>IV</sup> This image is continued by the circular wreaths of flowers that are laid at the grave-side and in the more covert Celtic mythology of the Underworld.<sup>V</sup> So it should come as no surprise to find Poseidon the brother of Hades, god of the underworld, with a temple at the very centre of Atlantis, and it should also be no surprise to find Jack Deth drawn towards the underworld city of Atlantis. As mentioned, Deth is so entranced by the sunken city, that he travels back in time to find his 'lost' shadow there.

---

<sup>1</sup> C. W. 9,I: 718

<sup>2</sup> Hillman, J., The Dream and the Underworld, (New York, 1979): p160

To return to the prototypical image of the circular city, it is well known that the classical Greek civilisation, as we do today, regarded the circle as a 'perfect' shape. In fact their universe was conceived of as a series of seven crystal spheres each of which contained one essential element of the universe. It has been observed by Eliade that the cities reflect, in their shape, the cosmology of that culture. Thus for ancient Greek society there is a stress on circular city shapes, like the city of Atlantis.

'Cities too have their divine prototypes. All the Babylonian cities had their archetypes in the constellations: Sippora in Cancer, Nineveh in Ursa Major, Assur in Arcturus, etc.... Not only does a model precede terrestrial architecture, but the model is also situated in the ideal (celestial) region of eternity'.<sup>1</sup>

The mandala, and labyrinth-like construction of cities can be observed in modern city plans, as in the examples below. What is significant is that the plans of modern cities are as much a projection of unconscious psychological images as supposedly rational planning decisions. Modern cities, for example, Los Angeles, are like their ancient and mythological counterparts, projections of an inner psychological landscape (this will be of importance when the plan/image of the city in Trancers is considered).

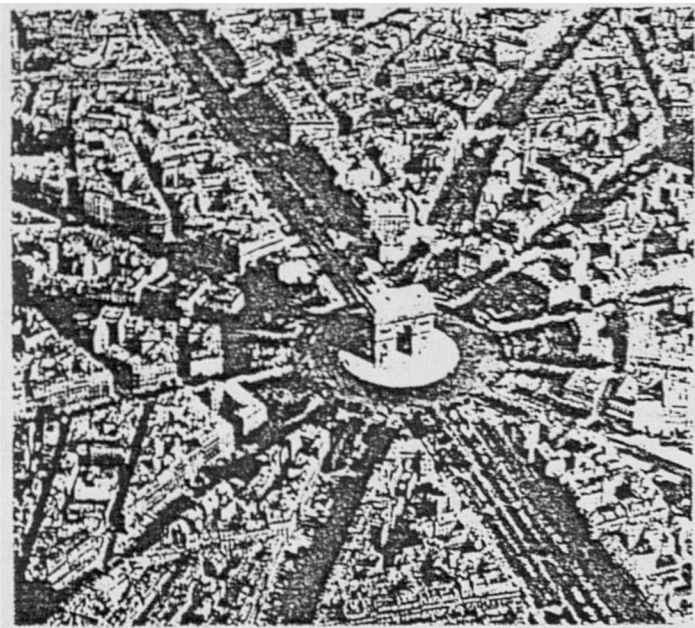

Paris, France

Extracted from, Man and His Symbols: p271

<sup>1</sup> Eliade, M., The Myth of the Eternal Return, (New York, 1954): p7

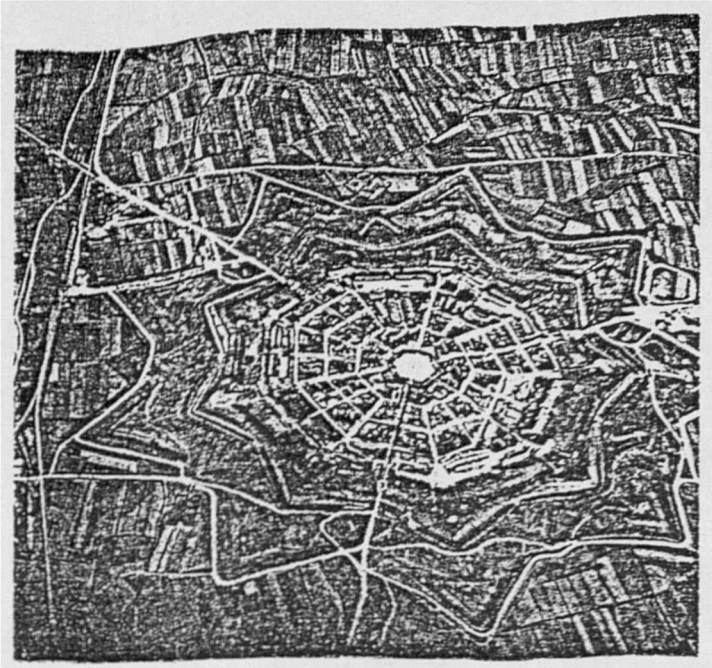

Palmanova, Italy

Extracted from, Man and His Symbols: p271

Before examining the image of the city in Trancers it is important to continue with this mythological and psychological context, as this will reveal other concealed mythological levels in the film.

Further investigation into the nature and origin of cities shows that originally city walls did not have a defensive purpose, and given the labyrinthine construction of the cities in Trancers this is important. The function of the city wall was to separate out a special space, a space which was distinct from the chaos which pervaded the rest of the universe. This is particularly important for the portrayal of the city in detective films, for given this origin of cities the detective is placed firmly inside the magical mandala-like protective circle of death. Eliade has commented on the way in which cities define space and has noted that,

'The same is the case with city walls; long before they were military erections, they were a magical defense, for they marked out from the midst of a "chaotic" space, peopled with demons and phantoms... an enclosure, a place that was organized, made cosmic, in other words, provided with a "Centre"'.<sup>1</sup>

<sup>1</sup> Eliade, M., Patterns in Comparative Religion, (New York, 1958): p371

The detective in Trancers and other detective films is placed firmly at the centre of a cosmological mandala, and rather than acting as a defensive circle, the city in Trancers, admits Deth, knowing that his presence is essential to a balanced existence.

The centre of the city, as it appears in detective films is often Chinatown. While in Trancers it by no means provides the most dominant location, it still provides the narrative centre. It is mentioned both near the start of the film when Deth is searching for the old Chinese theatre and at the end of the film because the final confrontation takes place in Chinatown itself. Levy-Bruhl has this to say about sacred places such as Chinatown:

'To these natives, a sacred spot never presents itself to the mind in isolation. It is always a complexus of things which includes the plant or animal species which flourish there at various seasons, as well as the mystical heroes who lived, roamed or created something there...'<sup>1</sup>

It now seems appropriate to explore the image of Chinatown as it is presented in Trancers.

The main significance of Chinatown is that it is foreign to the city that surrounds it. It is a special place that somehow is set aside from all that goes on around, and one of the reasons that it is so important to the detective genre is that it is the opposite of the city in which it is situated. It is also interesting to note that Jack Deth does not go to Chinatown of his own accord, but is instead directed there by his anima-guide, Leena. Here Leena has the use of a friend's flat and regards this as a safe place to be, 'no one will think of looking for us here' she comments<sup>VI</sup> and it is almost as though she recognises the protective qualities that Chinatown

---

<sup>1</sup> Levy-Bruhl, L'Experience Mystique et les Symbols Chez Les Primitifs, (Paris, 1938): p183

possesses. While clearly still part of the underworld, it is nevertheless different from the everyday world of crime in which it is situated and the cultural distinction between East and West underscores this separation. Chinatown represents the philosophy of the East, it is a place of inward searching or introspection, and it exists in opposition to the Western extroverted approach. In a way it represents the mystery of the inner world, almost as though a seed of the East has been planted in the West. Chinatown is as much an attitude of mind as it is a place and it is, therefore, somewhere where the detective can be at his most intuitive and magical. It is also a place where the detective has to fight many of his battles, because in Chinatown the combat between ego-consciousness (the Western attitude) and the shadow (the inner Eastern attitude) takes place. To enter this realm is to enter an area of transformations, both cultural and psychological. It belongs to the underworld and is a place of intuitions and a place where insight may be achieved before returning to the upper, or outside world.

In Trancers there is evidence to show that this particular Chinatown is buried, or rather, it is now covered in water. As Deth comes out of the sea, near the beginning of the film, he says that he has almost found the old Chinese theatre. In many ways this seems to provide the perfect setting for the final confrontation with Whistler.<sup>VII</sup> One form of Chinese theatre is a shadow play, it is a home for shadows or illusions and this seems to further substantiate the theory that he is chasing a ghost, or more accurately a shadow Whistler.

These characteristics of Chinatown, illusion, magic, and intuition are not limited to Trancers and in fact typify the representation of Chinatown in the detective genre. For example, in Big Trouble in Little China (Dir. John Carpenter, Twentieth Century Fox, 1986) these themes are evident in

abundance. The hero of this film, Jack Burton, has to rescue the heroine from inside a warehouse. The problem is that not only is this warehouse situated in Chinatown, but it is also the home of the evil spirit Lo Pan. Like the shadow characters in Trancers, Lo Pan can assume a bodily form, but only as a crippled old man, and his magical powers can only be activated when he is a spirit/ghost, or shadow. In order to rescue the stranded heroine, Burton enlists the aid of a Chinese sorcerer who goes with him into the underground labyrinth of the warehouse. With the help of magic potions, martial arts and Chinese black magic, Lo Pan is eventually destroyed. The significant thing in this is that it is Chinatown which represents the place where magic and illusions can live, it is a place where with the help from the appropriate people the hero can battle with the spirit shadow world. So it is no wonder that the final confrontation between Deth and his shadow takes place in Chinatown.

It is important to note that in Trancers, Chinatown is underground or rather underwater and as has been remarked it is Deth's quest to go into the underground in search of his shadow. It is therefore mythologically appropriate that two more places where he comes across trancers are also situated underground. First there are the trancer-punks who are in the night club under the flat that he and Leena are staying in, and secondly there are the trancer-drunks and here he falls through a weak roof in the warehouse to accidentally discover them.

This is typical of trancer, or zombie, movies where often the most unpleasant shadow figures live in underground labyrinths. For example in C.H.U.D. (Dir. Douglas Cheek, Bonime Productions, 1984) the creatures of the title (Cannibalistic Humanoid Underground Dwellers) live in the city sewers. These sewers run underneath the city in a complex and disorientating laby-

rinth of interconnecting drains, allowing the C.H.U.Ds freedom of movement. Their similarity to trancers can be seen in one of the remarks made by a character who escape from being eaten by one of the creatures. He accuses the police detective of being almost as evil as the C.H.U.Ds by saying, 'You go by name of being alive, and you are dead'. These creatures, like trancers, are the property of the underworld and in both films these half dead humans live in an underworld labyrinth.

### INTO THE LABYRINTH

There exist in Trancers two types of labyrinth, the vertical and horizontal. The horizontal labyrinth finds its expression in the image of the city and of Chinatown in particular. That the city is a modern day labyrinth is clear. Without the aid of a map or guide, confusion, bewilderment and frustration are bound to ensue, and this is true for the hero-detective in general and the detective in Trancers in particular. Jack Deth on arriving in Los Angeles has first to gain the assistance of Leena to find his way around the city, and again during the chase sequences the city proves to be full of dead ends and blind alleys, just like the cul-de-sacs encountered within a labyrinth.

The vertical labyrinth image takes two forms. First there is the labyrinth through time. This is the passage which links the diurnal nature of the upperworld to the nocturnal underworld of Los Angeles. Through this labyrinth of time travel and bodily uncertainty, Jack Deth proceeds on his quest, at one moment sure of his direction, at the next finding himself in a dead-end and suddenly recalled to Angel City. It is through these corridors that Whistler has retreated, down into the underworld to hide from Deth. This image is vividly paralleled in Francis Thompson's, 'The How'



of Heaven' in which the writer tries to hide himself from a pursuing God,

'I fled Him, down the nights and down the days;  
 I fled Him down the arches of the years  
 I fled Him, down the labyrinthine ways  
 of my own mind, and in the midst of tears<sup>1</sup>  
 I hid from Him, and under running laughter'.<sup>1</sup>

The second type of vertical labyrinth is the labyrinth through buildings. It is a convention within the detective genre to have the detective pursue the criminal through a building, often an office block or old house, and in the case of Trancers it is a disused warehouse. In the warehouse Deth is disorientated and is unable to find his way around. At one point he is attacked and cornered by a trancer relying on Leena to save him, and then suddenly the floor gives way and they fall down into the imagistic centre of the maze only to discover Hap Ashby, whom he was searching for. The warehouse has proved to be confusing and almost deceitful, yet at its centre it contains the prize that Deth needs, the ancestor of Margret Ash now the only surviving leader in the twenty-third century city. The labyrinth in Trancers, like its mythological ancestors, stubbornly defends its prize and it is only the hero who may attempt to capture its reward.<sup>VIII</sup> Thus in Trancers Deth has the complexities of a four dimensional maze to cope with, not just width and length, but depth and time also conspire to make his quest even more testing.

While it is impossible to determine exactly what the original purpose of a labyrinth was it does seem as though they are a type of defence, in which the deceitful and cunning walls try to conceal the way to the centre. As Eliade notes,

---

<sup>1</sup> Thompson, F., The Hound of Heaven, Lines 1-5, (London, 1913)

'Without being overhasty in deciding the original meaning and function of labyrinths, there is no doubt that they include the notion of defending a "centre". Not everyone might try to enter a labyrinth or return unharmed from one; to enter it was equivalent to an initiation. The "centre" might be a variety of things. The labyrinth could be defending a city, a tomb or a sanctuary but, in every case, it was defending some magico-religious space that must be made safe...'<sup>1</sup>

The labyrinth is therefore an image of protection against the outside world and it is the sacred space which is regarded as worthy of defence and protection. However, it is protection not just against physical attack from hostile neighbours, but also from psychological attack from the negative sides of the unconscious; from demons and spirits. The labyrinth becomes an image projected from the unconscious and while it may act as a physical defence it also acts as a psychological defence against the unconscious. To return to Eliade,

'Religiously, it (the labyrinth) barred the way to the city for spirits from without for the demons of the desert, for death. The "centre" here includes the whole of the city which is made, as we have seen, to reproduce the universe itself'.<sup>2</sup>

This notion of the labyrinth as a protection against the objective psyche, or rather as an image of psychological repression, (which of itself may not be neurotic), can be extended when the labyrinth is considered as an image of the individuation process. Here the concealed meanderings of its pathways represent the processes of assimilation, repression, suppression, etcetera examined in the previous chapter. In this model the sacred 'centre' space is the as yet unconstellated archetype of the Self.

Within the framework of analytical psychology, analysis, whether by oneself or with the aid of a psychiatrist, is regarded as a way of assisting the

---

<sup>1</sup> Eliade, M., Patterns in Comparative Religion, (New York, 1958): p381

<sup>2</sup> Ibid: p381

individuation process. This enables Jungian based analysts to see the analytic process as a mirror image of the individuation process, it too is a labyrinth and in the following quote Carotenuto brings together the incest themes of the hero, the labyrinth as an image of individuation, and the labyrinth as a way to achieve 'deep' awareness. In analytical psychology the labyrinth is a defence against the outer and inner worlds. At the same moment the labyrinth enables the patient to become introspective, and frustrates this attempt. Thus Jack Deth is able to enter and explore his own unconscious, projected onto the image of the labyrinth and yet the labyrinth frustrates him in his quest for individuation. To go deep is always to accept a frustrating and heroic quest.

'When an analysis begins, the archetypal motif behind the myth of Oedipus, that is, of consciousness, is generally constellated; the same myth underlies the myth of Theseus, who penetrates the labyrinth. This means that anyone who undertakes an analysis, even or especially if he has been driven to his knees by suffering and necessity and is initially unaware of what awaits him, chooses the path of deep awareness, which is in itself already a heroic act in that it requires one to achieve a relative view of consciousness and of the rational attitude predominant in our historical period. A withdrawal of energy from the outside world is also necessary, and for this a certain price must always be paid'.<sup>1</sup>

So far this discussion of the labyrinth has assumed that the labyrinth takes only one form, that is the confusing or deceitful labyrinth in which one is always in a state of isolation.<sup>IX</sup> It is these types of labyrinths which are ostensibly found in Trancers and indeed this type dominates the landscape of the modern and post-modernist world, as Diehl notes,

'With its intricate paths, blind ways, claustrophobic interior spaces, perplexing design, the labyrinth both creates and symbolizes the post-modern experience. It traps, isolates, alienates and confuses. It throws the viewer into the subjective experience of the Self'.<sup>2</sup>

---

<sup>1</sup> Carotenuto, A., The Vertical Labyrinth-Individuation in Jungian Psychology. Translated, Shepley, T., (Canada, 1981): p45

<sup>2</sup> Diehl, H., 'Into the Maze of Self: Protestant transformation of the image of the labyrinth.' The Journal of Medieval and Renaissance Studies, Vol.16. No.2 (Fall 1986): p281

However this type of maze, which is an image of the psyche or Self alienated from the totality of experience, is a fairly recent development of the labyrinth. There is a second and earlier type of labyrinth in which it is only necessary to follow the path to eventually arrive at its centre, as in the examples below:



Finnish Stone Maze  
(Bronze Age)



19th Century British  
turf maze



Maze in tiles at  
Chartres Cathedral

From, Man and His Symbols, Ed. Jung, C. G., (London, 1964): 177

It is striking that unlike the post-modern maze the subject is guaranteed success, the centre of the maze will be reached. Thus the maze of Chartres above, would be walked by pilgrims on their knees as a symbolic pilgrimage to the Holy Land, at the centre of this, and other medieval cathedral mazes is the Holy City of Jerusalem. So the questing pilgrim trusts in God and progresses deeper into the maze, in what has become a spiritual, rather than physical journey. An inner rather than outward quest.

'Like the post-modern mazes, these medieval mazes were apparently experiential. The experience of following the paths of the church maze, however, would not have been the modern one of fear, panic and impotence, but instead a spiritual experience one of meaningful action and, upon reaching the centre, deep fulfillment'.<sup>1</sup>

---

<sup>1</sup> Diehl: p284

The maze as it occurs in Trancers is both a source of alienation and growth, it is both a post-modern and medieval maze, for by entering and solving the labyrinth the hero is participating in his individuation. It is a place of challenge and comfort, defending the sacred space of the Self and yet trapping the demons and shadow figures of the underworld in its paths. Again the hero Jack Deth finds himself in the curious world of Enantiodromia as the labyrinth walls become at once a defence, and a gateway to the soul, which is the archetype of the Self.

At this point it will be helpful to examine other mythological occurrences of the labyrinth and to explore in what ways they parallel the myth themes found in Trancers. In the following quote from Campbell he brings together many of the themes that this chapter has been exploring, it regards the labyrinth as connected to sacrifice and death and often association with water imagery,

'In ancient Egypt the structure known as the Labyrinth... was a vast complex of buildings beside an artificial lake, with the tombs of kings and sacred crocodiles in the basement. The relationship (if any) of such megalithic structures and the rituals of their use in Egypt, Crete, and Ireland to the mortuary customs of remote Melanesia, which are also associated both with megaliths and with the symbolism of the spiral and the labyrinth, as well as with animal sacrifice... we shall consider when we come to the problem of origins...'<sup>1</sup>

It would seem from Campbell's comments that the association of the labyrinth with death is a universal or archetypal relationship. This association seems to reinforce the interpretation of the city in Trancers as a labyrinth, for as has been demonstrated, the mythological structure of the film is ultimately concerned with death. Throughout this chapter death has been viewed through an underworld perspective and within this framework

---

<sup>1</sup> Campbell, J., The Masks of God: Primitive Mythology, (USA, 1959). This edition, (London, 1984): p70

death becomes something which, while not final, is inevitable. Death becomes a way of living.

Aiding in this underworld perspective is the anima (Leena in Trancers) who helps those who wish to die in their conscious selves, and to enter the labyrinth of the underworld. This myth is strongly paralleled by a Melanesian death myth,

'In a myth of the Melanesian island of Malekula in the New Hebrides, which describes the dangers of the way to the Land of the Dead, it is told that when the soul<sup>1</sup> has been carried on a wind across the waters of death and is approaching the entrance of the underworld, it perceives a female guardian sitting before the entrance, drawing a labyrinth design across the path, of which she erases half as the soul approaches. The voyager must restore the design perfectly if he is to pass through it to the Land of the Dead. Those who fail, the threshold guardian eats. One may understand how very important it must have been, then, to learn the secret of the labyrinth before death ...'<sup>1</sup>

In this section of the chapter on the labyrinth it has been shown that in the mythology and myths of the maze it is possible to find direct parallels to the myth themes in Trancers. Specifically it has been demonstrated that the mythology of the labyrinth gives expression and form to the concepts of sacrifice, Axis mundi, Imago mundi, height and depth, rebirth, the underworld and its association imagery, especially water and death. It is therefore possible to regard the image of the labyrinth as the mythologem for Trancers. That is to say that all the myth themes, which are images of psychological themes, can be united and find expression in the central and 'foundation' myth of the labyrinth.

---

<sup>1</sup> Ibid: p68-69

Summary

- 1) The myth of Atlantis parallels the myth of 'Angel City'.
- 2) Within a mythological perspective the plan of a city is a map of the universe it is created in. The form, and ideal of the city is a projection of an unconscious, psychological cosmology, i.e. it reveals the psychological development of culture.
- 3) The city in Trancers, is imaged as a labyrinth, and consequently Deth requires the assistance of Leena to find his way through its pathways. The imagistic centre of this city is Chinatown.
- 4) The labyrinth is both a protection and a defence. As a projected psychological defence it unwittingly entraps the very objects it aims to exclude. For example in Crete, the Minator is trapped in the maze and in Trancers Whistler is trapped in Angel City.
- 5) The labyrinth is an image of the underworld and as such it helps to provide an underworld perspective on the other themes in Trancers, all these themes are reworked and find an expression in the central theme of the maze.

CHAPTER ELEVEN NOTES

- I. c.f. Appendix II, c.
- II. It is unimportant for this chapter whether a historical Atlantis existed or not, but for an entertaining and ingenious attempt to prove the existence of a historical Atlantis, c.f. Atlantis: the Antediluvian World, Donnelly, I., (USA, 1882).
- III. Mandala is the Sanscrit for circle.
- IV. c.f. Allcroft, A. C., The Circle and the Cross, Vol. I, (London, 1927).
- V. c.f. Riemschneider, M., Rad und Ring als Symbole der unterweit, (Stuttgart, 1962): 3:p46-63.
- VI. Note the only trancers within Chinatown are the disco trancer-punks and Whistler's attempt to trance Leena also fails. This is in part due to Leena's own strength, but may also be due to the location.
- VII. c.f. Appendix II, i.
- VIII. c.f. Virgil, The Aeneid, V: p588.
- IX. This is like the labyrinth examined in the analysis of Sleuth, c.f. Chapter Six, The Symbolic Search, p172-174. The remarks about the relationship between the labyrinth and narrative structure are also applicable to Trancers. (That the viewer of the film is in a type of labyrinth, increases his or her identification with the detective because they both have labyrinths to explore).
- X. The association of the anima with the labyrinth can also be found in the Greek myth of Aeneas, c.f. Ovid, Metamorphoses, Book VII, Lines 162-167.



Chapter Twelve

The Process of Individuation

'Only the spirit, if it breathe upon the clay,  
can create Man'.

Antoine de Saint-Exupery

Wind, Sand and Stars

INTRODUCTION

It is the aim of this chapter to examine the process of individuation as it is represented in Trancers and while doing this, two themes will be explored. First, the general images of individuation will be examined and secondly the specific images of Jack Deth's individuation will be analysed.

ENANTIODROMIA: THE GENERAL IMAGES OF INDIVIDUATION

This chapter has regarded the concept of Enantiodromia as central to the process of individuation, in other words it is part of the work of individuation to transform an image into its Enantiodromaic equivalent. Before detailing the specific opposites which are the working out of the individuation process in Trancers, it is important to state that Enantiodromia is only one of the ways in which opposites behave, it is however the most important way as it represents the field of transformation which embraces all the oppositional functions. In this sense, it is like the alchemist's crucible which contains the Prima materia ready for its subsequent change.

Jung has identified three other processes which seem to organise the behaviour of opposites, these are: self regulation (the regulation of a pair by its opposite), conjunction (the union of opposites) and Coincidentia Oppositorum (the identity of opposites).

'In this sense,... conjunction and... the identity of opposites mean the simultaneous perception by the perspectives of life and death, the natural and psychic. Conjunction, then, is a peculiar union of inner viewpoints. Through this union, an identity of opposites becomes apparent. We see the hidden connection between what had hitherto been oppositions'.<sup>1</sup>

---

<sup>1</sup> Hillman, J., The Dream and the Underworld, (New York, 1979): p79

What follows is a table of some of the oppositions contained within Trancers. These oppositions are presented within the transformative context of Enantiodromia, and within this working out of the individuation process opposites are first realised and then transformed. It is during this process that the archetypes are constellated and then assimilated into the functioning of ego-consciousness.

Enantiodromia

Opposition	Self regulation	Conjunction	Coincidentia
Hero	Shadow (Whistler)		
Anima	Animus-Hero (Deth)		
Height/Depth	Up and down the line	Angel City/ Los Angeles	
Inner/Outer			Labyrinth
Wet/Dry			Atlantis/ Los Angeles
Conscious	The Underworld, Los Angeles		
Life/Death		Sacrifice of hero	Rebirth
Labyrinth		Death & Rebirth	
Quest		Return	
Body/Spirit			Trancers

A table indicating some of the oppositions in Trancers  
and the individuation process

The table demonstrates that the main themes in Trancers can be viewed as parts of an oppositional system: The different forms of opposition help to show that apparently non-oppositional themes, for example the labyrinth are in fact composed of opposition. The distinction is not unlike the difference between archetypal pattern and image, only here the labyrinth forms the

image and the oppositional themes make up the pattern which underlies it. However the myth themes of Trancers, despite being by their nature composed of opposites, all flow in the one direction, that is towards individuation, and the reason for this is straightforward. Individuation involves bringing into consciousness latent unconscious oppositions, and as the individuation process progresses, it is realised that these 'opposites' are not in opposition to each other at all, but in fact 'run into' each other. (Enantiodromia). The opposites in Trancers are psychological projections of an inner, but as yet unconscious, process of individuation. As to whose individuation the answer must be Jack Deth's, and yet this individuation also has a cultural dimension, because it is the culture which has reincarnated the archetypal pattern of the hero in the image of Jack Deth.

In keeping with the above observations, and the underworld perspective, it seems important to note that the ultimate end of individuation, be this personal or cultural, is death. As Jaffé has commented, 'The psychological path of individuation is ultimately a preparation for death'.<sup>1</sup>

While death may be inevitable the underworld perspective adopted for the observations of this chapter, has also shown a consequence of this death is rebirth, or rather that death involves dying to old self, in order that the archetype of the Self can be constellated. In the mythology of Trancers this means that Deth must 'die' to his shadow-side before his anima can be assimilated into ego-consciousness, and it is with this psychological quest that he enters the labyrinth of the underworld. Here there exists one of the central oppositions of the film, while Deth is on a search for the new life, or rebirth, that individuation brings, he must also accept the death

---

<sup>1</sup> Jaffé, A., Bilder und Symbole aus E.T.A. Hoffman's 'Märchen Der Golden Topf', in: 'Gertaltungen des Unbewussten', Ed. Jung, C. G. (Zurich, 1950). Cited in Hillman (1979): p89

that his name implies. So once again there seems to be a mythological, and hence psychological association between the process of individuation, especially the shadow and the anima stages, and death. In view of the importance of the labyrinth in Trancers, it is interesting to note that the mythological antecedents of this insight are found in the image of the maze.

'... the labyrinth, maze, and spiral were associated in ancient Crete and Babylon with the internal organs of the human anatomy as well as with the underworld, the one being the microcosm of the other. "The object of the tombbuilder would have been to make the tomb as much like the body of the mother as he was able,"... since to enter the next world, "the spirit would have to be re-born".'<sup>1</sup>

Again the themes of death, life, rebirth and individuation are interwoven, and find expression in the image of the maze. Deth enters the maze and follows its path as best he can, ultimately he has no option but to trust the archetypal spirits that line its ways. Rather than trying to dam these rising waters of the archetypally populated unconscious, Deth dives into its watery depths, and like the lost city of Atlantis, submerges himself in its cleansing powers. Much as any diver relies on water to bring him eventually to the surface, so too Deth, and all on the quest of individuation, rely on the objective psyche to eventually relinquish its hold and to return the subject to the world with an increased awareness of ego-consciousness. Until such time as this happens, there is no option but to battle with the forces of the objective psyche. The result of this is that the unconscious becomes both a place of trust and combat. For the medieval pilgrim following the cathedral labyrinth,<sup>1</sup> in other words, tracing his individuation, the situation was similar,

'Though the pilgrim would not be able to see the whole design at once, he could act with the faith that a comprehensive design existed, and that the path led to heaven and God, the symbolic centre of the maze'.<sup>2</sup>

---

<sup>1</sup> Campbell, J., The Masks of God: Primitive Mythology, (USA, 1951). This edition, (London, 1984): p69. Citing Jackson Knight, W. F., Maze Symbolism and the Trojan Game

<sup>2</sup> Diehl, H., 'Into the Maze of Self: Protestant transformation of the image of the labyrinth'. The Journal of Medieval and Renaissance Studies, Vol. 16: No.2 (Fall, 1986): p284

As previously commented this type of certainty does not exist in the post-modern maze, and any psychiatrist can attest to the destructive and possessive powers of the unconscious. It is indeed a heroic task to attempt to conquer, or even explore the depths of the objective psyche and yet it is an inevitable process. Everyone is called to individuation, both personally and culturally, as the individual is but a microcosm of the culture and of humankind. As Edinger puts it, 'The hero is a figure lying midway between the ego and Self. It can perhaps best be described as a personification of the urge to individuation'.<sup>1</sup> Given this it now seems appropriate to examine the ontogenesis of the hero's individuation as it is represented in the quest of Jack Deth.

#### THE INDIVIDUATION OF JACK DETH

It is true to say that the ontogenetic individuation process is also phylogenetic, for individuation is about realising the collective qualities that each individual shares with humanity, that is humanity past and present. As Jung puts it, 'Individuation does not shut one out from the world, but gathers the world to oneself'.<sup>2</sup> It is a realisation of the universe that we carry around in our humanity, or if it is preferred, in our objective psyche. This naturally includes both the positive and negative aspects of being human, for as already mentioned individuation involves the assimilation of the shadow, and ultimately ends in death. Jung comments that,

'There are many spirits, both light and dark. We should, therefore, be prepared to accept the view that the spirit is not absolute, but something relative that needs completing and perfecting through life'.<sup>3</sup>

---

<sup>1</sup> Edinger, E., The Bible and the Psyche: Individuation Symbolism in the Old Testament, (Canada, 1986): p45

<sup>2</sup> C. W. 8: 432

<sup>3</sup> C. W. 8: 645

The individuation of Jack Deth has reached the phase where he must assimilate his shadow and then accept his anima. What exists in Trancers is a symbolic transformation between these two archetypes. It is clear that Deth has not repressed, nor suppressed, his shadow for it is visible in the figure of Whistler. Whistler, like Deth, is a detective, or more accurately a police-detective, and his assimilation in the film takes the form of his death. In a sense this is not really his death at all, for although the body of Whistler has been destroyed, his consciousness is still alive. In the film it remains unexplained where Whistler's consciousness goes, in psychological terms the answer is clear, it becomes part of Deth. It becomes assimilated, or integrated into his psyche.

'The ideas of wholeness and creative growth cover the old hubris of the hero, and the path of integration is his old heroic journey in which he meets all the freaks of nature that are also divine forms of the imagination. As he proceeds from figure to figure, station to station, they disappear. Where have they gone when they are overcome and integrated, but into his own personality, divinizing man into the apotheosis of a gigantic freak himself'.<sup>1</sup>

In fact the hero is no more freakish now than he was before, he has gained no new deformity or horror, all that has happened is that latent unconscious material has now become conscious. The hero is no more a freak than he is a shadow, for in the process of assimilation the very concept of shadow has been transcended.

Of course it is a matter of debate whether Deth has assimilated his shadow or not, however the filmic evidence does seem to point towards a successful assimilation. For example at the end of the film Deth discards his raincoat, a symbol of his persona, before going on to fight with the shadow, Whistler. This is important because it indicates a movement into the depths

---

<sup>1</sup> Hillman, 1979: p99

of his psyche. By this time he has spoken with Leena indicating his love for her, and his commitment to her, and as an anima figure she again points towards an inner movement. In the final sequence of the film Whistler tries to reason with him but he determinedly sends Whistler up the line. Apparently he has been assimilated into his ego-consciousness.

However an ambiguity exists in this final confrontation between Whistler and Deth. As Whistler is speaking to Deth there is a close-up of Whistler's face, showing clearly his hypnotic staring eyes. Is he trying to turn him into a trancer, and does he succeed? It seems unlikely that Whistler is successful as Deth quickly sends Whistler's consciousness back to Angel City where he does not have a body to inhabit, but perhaps this is what Whistler wants. The important point is that the viewer of the film does not know, and the ambiguity on this point is heightened by the final shot of the film. Here the puer<sup>II</sup> figure of MacNulty's ancestor mysteriously steps out of the shadow of a building. Perhaps MacNulty has returned to singe a tranced Deth or maybe to take him back to Angel City.

Again the viewer is presented with ambiguity, and remains unsure as to the eventual outcome. However, it does seem as though the weight of evidence falls firmly on the completion of the shadow phase. The discarding of the raincoat, sending Whistler up the line, and the desire to stay with the anima figure of Leena all point towards assimilation of the shadow. In this assimilation there exists an aggregate of archetypes which gather around the shadow. Here in the film's final sequence the inter-related archetypes achieve a balance and stasis between the outer man or persona, and the inner man or shadow.<sup>III</sup> This pre-figures the next phase of individuation which is the assimilation of the anima, because the inner man walks hand in hand with the inner woman.



The Christian mystic John Ruysbroeck, divides what is the individuation process into three parts, which are three types of unity or wholeness, and they provide a useful skeletal framework within which to view Deth's individuation. Ruysbroeck also describes the individuation process in a highly religious manner, and remembering the numinosum connected with this event this is not entirely inappropriate.

'The first and highest unity of man is in God; ... the second unity or union is also in us by nature. It is the unity of our higher powers; for as much as these spring naturally as active powers from the unity of the mind or of the spirit ... The third unity which is in us by nature is the source of all bodily powers, in the unity of heart; origin and beginning of the bodily life'.<sup>1</sup>

If these three phases described by Ruysbroeck are taken in reverse order, that is the third unity corresponds to the early stages of individuation then a clearer and simpler perspective on Deth's individuation is achieved. The third unity of bodily powers corresponds to the stage in individuation called ego centroversion. Clearly Deth has achieved this, as his strong persona shows<sup>IV</sup> he has established his ego centre and is able to move deeper into himself. It is the second unity that Deth has reached, he is concerned with unity of spirit both evil, (shadow) and good, (anima) and these have to be integrated into his ego-consciousness.

That Deth has identified and passed through the persona phase is characterised by his ease in 'playing roles' or if it is preferred, in adopting the appropriate persona for the situation. For example at one moment he is a police detective, then a lone-detective, then a lover, the next a tramp and finally, a saviour. These roles become interchangeable depending upon their usefulness. Also Deth is clearly in pursuit of his shadow and it is

---

<sup>1</sup> Ruysbroeck, J., The Adornment of the Spiritual Marriage. The Book of the Supreme Truth. The Sparkling Stone. Translated Wynshenk, C. A. (London, 1916): p11:2

this phase of individuation that follows the persona stage. As he goes deeper into the labyrinth of the objective psyche, so the objective psyche liberates the shadow, and then the anima, who act as his guides, although not always trustworthy guides into the underworld. As Edinger comments,

'This theme of reciprocal movement, in which the ego seeks the guidance of the unconscious while the conscious seeks the attention of the ego, is characteristic of the process of individuation'.<sup>1</sup>

This second unity of Ruysbroeck's includes all spirits, both dark and light, the evil and good. It seems as though while Jack Deth is involved with integrating his shadow, his anima is also present, for as mentioned the inner man and inner woman exist in a state of partnership. Throughout the film Deth has to rely on Leena to guide him to his shadow, and once this has been achieved, she also provides the motive for its assimilation; that Deth can stay in Los Angeles with her. That Leena is in fact Deth's anima and that what is occurring is Deth's individuation is made explicit in the following alchemical parallel, but before this it is important to restate that Leena is a distant relative of Deth's. In a way she is his mother and wife substitute yet she is also young enough to be his daughter, and this incest theme is integral to the hero's individuation. Jung cites the following alchemical manifestation of the anima,

'The Queen of Sheba, Wisdom, the royal art, and the "daughter of the philosophers" are all so interfused that the underlying psychologem clearly emerges: the art is queen of the alchemist's heart, she is at once his mother, his daughter, and his beloved, and in his art and its allegories the drama of his own soul, his individuation process, is played out'.<sup>2</sup>

That Deth has not yet assimilated his anima is evident from the, as yet, incompleting incest motif, and from a dualism of body and spirit which is

---

<sup>1</sup> Edinger, 1986: p79

<sup>2</sup> C. W. 14: 543

evident in Trancers. It is worth noting that the Conjunction depicted by the overt symbolism above the bed of Leena and Jack Deth<sup>V</sup> is not physically realised and hence psychologically the anima remains distinct from ego-consciousness. It is also interesting that this symbol is seen reflected onto the appearance of Whistler on the television, it is almost as though the 'illusion' of anima assimilation lies beyond the shadow figure of Whistler. This image again shows that the archetypes of shadow and anima are interrelated. While Deth may be on a quest to assimilate his shadow, he is also preparing for the next stage in his individuation which is anima identification and assimilation.

As Deth prepares through his shadow quest for the anima assimilation phase, which would ipso facto remove or transcend the body spirit dualism, he also pre-figures the mana personality phase and the eventual establishment of the archetype of the Self. The only way for Deth to assimilate his anima and move on to the next stages is for him to die to ego-consciousness. As this chapter has constantly stressed, it is only through entering the underworld, through dying that life can be achieved. Deth knows this, and that is why, while his body remains suspended, almost sleeping, his ego-consciousness descends into the objective psyche. He goes to die in the labyrinth of the underworld. As Heraclitus comments,

'When we are alive our souls are dead and buried in us, but when we die, our souls come to life and live again'.<sup>1</sup>

Or in a different translation which stresses the dream-like qualities of the descent,

---

<sup>1</sup> Heraclitus, Translated Cornford, Greek Religious Thought, (London, 1923): p81

'Man in the night kindles a light for himself,  
 though his vision is extinguished;  
 though alive he touches the dead, while sleeping:  
 though awake, he touches the sleeper'.<sup>1</sup>

This type of dualism is also found within the Christian tradition, in the following quotation from Corinthians the Apostle Paul draws together several of the mythological themes that have been discerned in Trancers. Paul believes that there are two bodies, the physical and the spiritual, of which the physical is the inferior and for those who have led the Christian life the promise is that they will be raised from the dead in their spiritual bodies. This resurrection, in the spirit, is guaranteed by the hero-Christ, who has already undergone this process and in so doing made it possible for the rest of mankind. Here Paul uses the mythological language of the Old Testament in which he describes Christ as the second, or final Adam. Thus Christ is seen as directly linked to Adam, as completing Adam's individuation (the name Adam means mankind).

'So will it be with the resurrection of the dead. The body that is sown is perishable; it is raised imperishable; it is sown in dishonour, it is raised in glory; it is sown in weakness, it is raised in power; it is sown a natural body, it is raised a spiritual body. If there is a natural body, there is also a spiritual body. So it is written: "The first man Adam became a living being"; the last Adam, a life-giving spirit'.<sup>2</sup>

It is for Jack Deth to integrate his anima and move towards the constellation of the archetype of the Self, he must become a 'life-giving spirit'. In doing this, a relationship is established with the Self which is characterised by numinous mystical language and experience, for the Self represents what it is to be fully human, as Shorter has written,

---

<sup>1</sup> Heraclitus, Frg. 26. Translated Marcovitch

<sup>2</sup> The Bible, New International Version. I Corinthians, 15: p42-45

' "Individuation appears, on the one hand, as the synthesis of a new unity which previously consisted of scattered particles, and on the other hand, as the revelation of something that existed before the ego and is in fact its father or creator as well as its totality". When this happens, one's view of oneself as merely human and self-sufficient has to be sacrificed. To take the risk of ascent knowingly will be with consciousness of one's own I/Thou relatedness'.<sup>1</sup>

If Deth is to succeed in his individuation then he must become a human sacrifice, sacrificing himself and his self-sufficiency in order to establish the existence of the Self. It is through the integration of the Self into ego-consciousness that one's own I/Thou relatedness is achieved. The hero becomes both fully a human hero and fully divine, and the individuation process is complete.

#### CONCLUSION

This chapter has explored the myths, symbols and myth parallels to the central quest theme of Trancers. This process has been pursued within the framework of analytical psychology and all the film's mythological and symbolic themes have been revealed as unconscious projections of the objective psyche, and as images of the individuation process. The findings of this chapter can best be summarised as a series of key points.

- 1) The use of analytical psychology has shown that there is a complicated structure of myths and symbols which lie beneath the film's surface narrative and images.
- 2) All the film's mythological themes are an integral part of the individuation process. They not only reflect, but condition individuation.

---

<sup>1</sup> Shorter, B., An Image Darkly Forming: Women and Initiation, (London, 1987): p127, (Citing Jung, C. W., C. W. 11: 400)

- 3) In understanding the images, myths and symbols of this and other detective films, it is essential to adopt in part, the mythological perspective of the underworld. It is only via this perspective that ego-consciousness can move towards an understanding of these projections and communications from the objective psyche.

CHAPTER TWELVE NOTES

- I. c.f. Archetypal Pattern and Mythology, Chapter Eleven: p309.
- II. The 'puer' is that element in the psyche which remains undeveloped and essentially a child, c.f. C. W.I,9: 259-305.
- III. c.f. Individuation and the Detective, Chapter Seven: p194-200.
- IV. c.f. Archetype's Image and Archetypal Pattern, Chapter Eight: p231-241.
- V. c.f. Appendix II, h.

CONCLUSION



CONCLUSION

This thesis has been exclusively concerned with applying analytical psychology to the study of film, and as such the theoretical and critical perspectives of other schools have largely been ignored. As part of this concluding section, it is appropriate to reach out over the waters, as it were, to our Freudian neighbours, because at the most basic level there are theoretical assumptions which are shared. The most important of these is that the unconscious is regarded as a dynamic system, and this concept is a common bond which links Jungian analytical psychology with Freudian psychoanalysis. As Samuels notes,

'The notion that the psyche is dynamic rather than static is fundamental to Freudian, Jungian and post-Jungian psychology ... This is enhanced in the Jungian view by the proposition that there is<sup>1</sup> also a self-regulatory function within the unconscious'.

The idea that the unconscious has a self-regulatory function is very important and underlies the assumption that the psyche is composed of oppositions. As has been constantly stressed these oppositions do not exist in a simple dialectical relationship but are more like a holistic system in which the oppositions regulate and balance each other to result in a dynamic yet stable system. An example of this is the way in which the objective psyche may constellate the archetype of the shadow to compensate for a deficiency in ego-consciousness. This process was observed in Chapter Three, the analysis of Tightrope (Dir. R. Tuggle, Warner Brother, 1984), which showed that the criminal was a projection of the detective's shadow. In this example the shadow was both balancing the detective's over-reliance on his persona and directing him towards the next stage of the individuation process which is the contrasexual phase.

---

<sup>1</sup> Samuels, A., Jung and the Post Jungians, (London, 1985): p8

The assumption which underlies this, and which also formed the basis of the theoretical position for the thesis, is that it is the archetypes which govern, or control the individuation process. Going one stage further, the archetypes also form the basic patterns for all life processes. This is a distinct position within analytical psychology and one which 'classical' analytical psychologists would disagree with.<sup>1</sup> Yet it is both a development of Jung's original thoughts and true to his intentions, as he notes,

'Psychology, as one of the many expressions of psychic life, operates with ideas which in their turn are derived from archetypal structures and thus generate a somewhat more abstract kind of myth. Psychology therefore translates the archaic speech of myth into a modern mythologem - not yet, of course, recognized as such - which constitutes one element of the myth "science".'<sup>1</sup>

What makes this approach fruitful is that it places a very great stress on the image. The image is not just a conscious expression of an unconscious archetype, but is a way which the objective psyche "plays" with the archetypes. In other words, images represent the objective psyche's attempt to provide psychological stability through the compensatory use of the archetypal structures.

When theorising about the psychological nature of film this is clearly of great importance. Consequently the model for film analysis that was established in Chapter Four (c.f. also Appendix III) centred around the function and expression of the archetypes. Four of its five sections were directly concerned with either the archetypal patterns present in the film, or with their associated imagery. Even the remaining square, which dealt with mythological material, was examined within the context of the archetypes. Indeed this process of finding mythological parallels was designed to help the analyst 'play' with and 'feel' the images, i.e. respond to them intuitively

---

<sup>1</sup> C. W. 9,I: 302

and non-rationally. Yet at the same time it still exploits the 'thinking' aspect of the psyche which is so necessary for critical work.

In Chapter Five the model was used to enable the analysis of Blade Runner (Dir. R. Scott, Columbia, 1982). This detailed analysis of the film demonstrated that analytical psychology could be used to explore both the narrative of the film and its characters. It further showed that these elements rested on deeper archetypal foundations which are, in turn, discernible in its visual surface. This showed that the film is not, as is often claimed, only a 'design' film, but that it also possesses deep mythological and psychological structure.

If archetypes exist, then they must have a function or purpose. Chapters Six and Seven were concerned with this purpose and with the way in which symbols, as a specific type of image, give expression to the archetypes. The purpose of the archetype is ultimately to propel the psyche towards individuation, which completes itself in the realisation of the archetype of the Self. The Symbolic Search, Chapter Six, with reference to two films Sleuth (Dir. J. L. Mankiewicz, Fox, Rank, 1972) and Woman in the Window (Dir. F. Lang, RKO, 1944), demonstrated in a symbolic reading of specific passages how the films' central characters (Tindel or Wanley) were going to psychologically develop. This development was then equated with the unfolding of the onscreen narrative. The key point is that the visual and narrative surface of the film is understandable in terms of archetypal patterns and psychological developmental structures.

Chapter Seven explored in depth the stages of the individuation process and related these to the psychological development of the detective as it is represented in films. It is a consequence of this position that the arche-

types as represented in films refer not only to the psychology of the characters, but also to a collective psychology. It would therefore be a claim of this thesis that film is understandable as a psychological medium which represents unconscious shared archetypal structures. This has important consequences for the interpretation of films. It is no longer enough to resort to the simple paradigm of reader/text where an interpretation tries to generate meaning from a 'reticent' film. The situation is much more akin to psychological analysis where the function is to make conscious the latent archetypal structures. If, as has been stressed, symbols, archetypes, myths are all ultimately beyond the grasp of rational comprehension then the attempt to create the ultimate meaning from a film is pointless. Rather the aim should be to gradually bring into consciousness an awareness of the deep archetypal structures which are imaged in the films, and in so doing to aid, in some small way, the process of cultural individuation.

This was the intention of the analysis of Trancers (Dir. R. Band, Lexyen Productions, 1984). While it was a close textual reading of the film, it also exploited the advantages of archetypal analysis, as it left the immediate confines of the film and explored its related mythological themes. In other words while the analysis did attempt an interpretation of the film, it was one which was based on shared psychological and mythological structures. Thus the film provided the context for the psychology, (myths, characters, symbols, etcetera) and the psychology the context for the film (archetypes, individuation). Perhaps this tension between two poles is what Jung would have advocated, and it is certainly implicit in the concept of Enantiodromia.

In conclusion it is important to identify the areas which are latent within the thesis, that could profitably be explored in the future. As this thesis

has pointed up the relationship between the detective and the shadow, it seems logical to follow the path indicated by the archetypes in individuation and to explore the subsequent anima/detective association. The basis for this work can be found in Chapter Seven, Individuation and the Detective and Trancers. These sections identify the two faces of the anima, the femme fatale and the helpful guide. In other words, it would be interesting to further investigate the anima as both an archetypal figure and as a determining constituent of genre.

Another area which could usefully be explored is the psychology of the auteur and the manipulation of the film medium to explore and express psychological themes. (Directors like J. Boorman, N. Roeg, D. Lynch would be particularly appropriate subjects). This would explore the relationship between the individual psychology of the director and the wider cultural (archetypal) psychology of the film audience. As such the cinema screen becomes an interface between the personal and the collective. Roland Barthes may well have been right in proclaiming the 'death of the author', for in the terms of analytical psychology he has become like an alchemical vessel, a vessel which transforms the archetypal patterns of the objective psyche into the collective images of the film.

While these themes have pointed to some new possibilities they remain areas for future research. This thesis has concentrated on the more fundamental task of creating a model which enables the systematic application of analytical psychology to the analysis of films. This has shown that underlying the narrative and visual surface of the analysed films there exists a complex mythological structure which is inherently psychological in its operation. In short, while the myth of films has been detected, the quest for greater understanding continues.

CONCLUSION NOTE

- I. For a detailed examination of the different schools of analytical psychology and their specific emphases c.f. Samuels, A., Jung and the Post Jungians, (London, 1985): p11-22

Glossary

GLOSSARY

AFFECT. This is associated with emotions and feelings. The AFFECT is so strong that, unlike feelings, it can only be repressed with difficulty. Can cause obvious psychomotor disruptions.

AMPLIFICATION. The rational associations brought to an image by the analyst - normally within the analytic context.

ANIMA/ANIMUS. The 'feminine dimension of man's unconscious and vice versa. ANIMA and ANIMUS may appear as personified figures, but it is more accurate to think of them as representing archetypal patterns. Modern Analytical Psychology tends not to link these and other psychological characteristics to gender, but regards them as alternative modes of behaviour, perception and evaluation. They may also be regarded as forming a bridge between the EGO and the OBJECTIVE PSYCHE.

ARCHETYPE. An innate structuring potential which is inherent in the OBJECTIVE PSYCHE. N.B. It is the pattern which is inherited and structures the development of the PSYCHE, and not the image it assumes. It is the ARCHETYPES which govern the INDIVIDUATION PROCESS.

ASSOCIATION. The connection of ideas or perceptions because of similarity, coexistence or opposition.

COLLECTIVE UNCONSCIOUS. c.f. OBJECTIVE PSYCHE.

COMPENSATION. This involves the balancing and regulating of the PSYCHE. Jung regarded the compensatory activity of the unconscious as balancing any 'defects' in consciousness.

COMPLEX. A collection of interrelated ideas and feelings which have an effect on conscious behaviour and experience. The concept of complex is central in the development of ANALYTICAL PSYCHOLOGY.

CONTRASEXUAL ARCHETYPES. The ANIMA and ANIMUS.

ECTOPSYCHIC SYSTEM. The outer functions of the PSYCHE: sensation, thinking, feeling, intuition. c.f. TYPOLOGY.



EGO. The center of consciousness. The EGO both maintains personal identity and responds to the OBJECTIVE PSYCHE by moving the PSYCHE towards INDIVIDUATION and the SELF.

ENANTIODROMIA. The tendency of opposites to 'run into' each other, so that cycles such as; life, death, rebirth are established.

EXTRAVERT. An attitude of personality whose energies are primarily directed towards the external world of people and events, rather than the inner world of ideas and feelings.

HERO. An archetypal pattern which correlates with the SELF. Jung describes it as, 'a quasi-human being who symbolises the ideas, forms and forces which mould or grip the soul'. C. W. 5: 259

IDENTIFICATION. An unconscious PROJECTION of parts of the personality onto a place or person, thereby justifying the projecting person's behaviour patterns.

INDIVIDUATION. The life process governed by the archetypal patterns, in which a person becomes totally himself, and this involves integration of the conscious and unconscious parts of the PSYCHE.

INTROVERT. An attitude of personality in which he or she is more concerned with their own inner world. Ideas and feelings tend to be of more importance than places and events.

MANA PERSONALITY. A personality who gives to an individual, or group, the feeling that their conscious state can be heightened. The HERO is a forerunner of this figure. Guru figures such as Casteneda's Don Juan are MANA PERSONALITIES.

MANDALA. A magic circle, often divided into four. As a symbol of psychological unity it represents a phase in the development of the INDIVIDUATION PROCESS. This is may be the completion of any of its stages and the MANDALA marks the point at which the transition occurs.

MYTHOLOGEM. The central or unifying theme of a myth.

MYTHOLOGY. The language or images that a myth assumes. For example the Arthurian MYTHOLOGY and the detective MYTHOLOGY share the same MYTHOLOGEM: that of the quest.

NUMINOSUM. 'The NUMINOSUM is either a quality belonging to a visible object or the influence of an invisible presence that causes a peculiar alteration of consciousness'. C. W. 11: 6. Jung also regarded experience of the NUMINOSUM as part of all religious experience.

OBJECTIVE PSYCHE. A term used by Jung to indicate that the PSYCHE is an objective source of insight and knowledge. It also indicates that some of the PSYCHE is objective, as opposed to subjective and personal, in nature.

ONTOGENY. The development of an individual through the course of its life cycle.

PERSONA. Literally a mask. This mask is worn by the individual and is the way in which he or she approaches the world. As an ARCHETYPE it has the function of mediating between the EGO and the exterior world.

PHILOGENY. The development of the species.

PRIMORDIAL IMAGE. A term that Jung originally used in place of ARCHETYPE.

PROJECTION. Difficult, or positive, emotions or parts of the personality are transferred onto another person or place. It is also a way in which the contents of the OBJECTIVE PSYCHE are made available to ego-consciousness. However to be of real use to ego-consciousness these projections must be dissolved, that is recognised. PROJECTION most frequently happens with the ARCHETYPES of SHADOW, ANIMA and ANIMUS.

PSYCHE. The 'totality of all psychic processes, conscious as well as unconscious'. C. W. 6: 797. Symbolised by the MANDALA, square, circle, etc.

PSYCHOSIS. A state in which something 'unknown' takes possession of the PSYCHE. This is an invasion by the OBJECTIVE PSYCHE in which it takes control of ego-consciousness.

SELF. The SELF is the central unifying principle of the PSYCHE, and is the archetype of man's fullest potential and unity of personality.

SHADOW. The apparently negative or inferior parts of the PSYCHE. In fact these are just parts of the PSYCHE which have not been developed and integrated with ego-consciousness.

SPONTANEOUS IMAGE CREATION. A creation of the unconscious, often a dream but may also include paintings, poems, films, etc.

SYMBOL. A NUMINOUS representation produced by and of the OBJECTIVE PSYCHE, which seeks to unify and overcome opposition.

TRANSCENDENT FUNCTION. This function mediates between opposites of the PSYCHE and uses the SYMBOL to transcend the contradictions inherent in such opposition.

TYPE. c.f. TYPOGRAPHY.

TYPOGRAPHY. This is a personality system developed by Jung to show different modes of psychological functioning in terms of personality types. There are two key categories, or attitudes INTROVERT and EXTRAVERT, which combine with the four functions, sensation, thinking, feeling and intuition, to determine an individual's personality TYPE.

UROBOROS. A universal motif, often associated with Gnosticism, of a serpent curled into a circle and eating its own tail. A SYMBOL of death and rebirth.

APPENDIX I

A Collection of Stills from Blade Runner

(Dir. R. Scott, Columbia, 1982)

a)

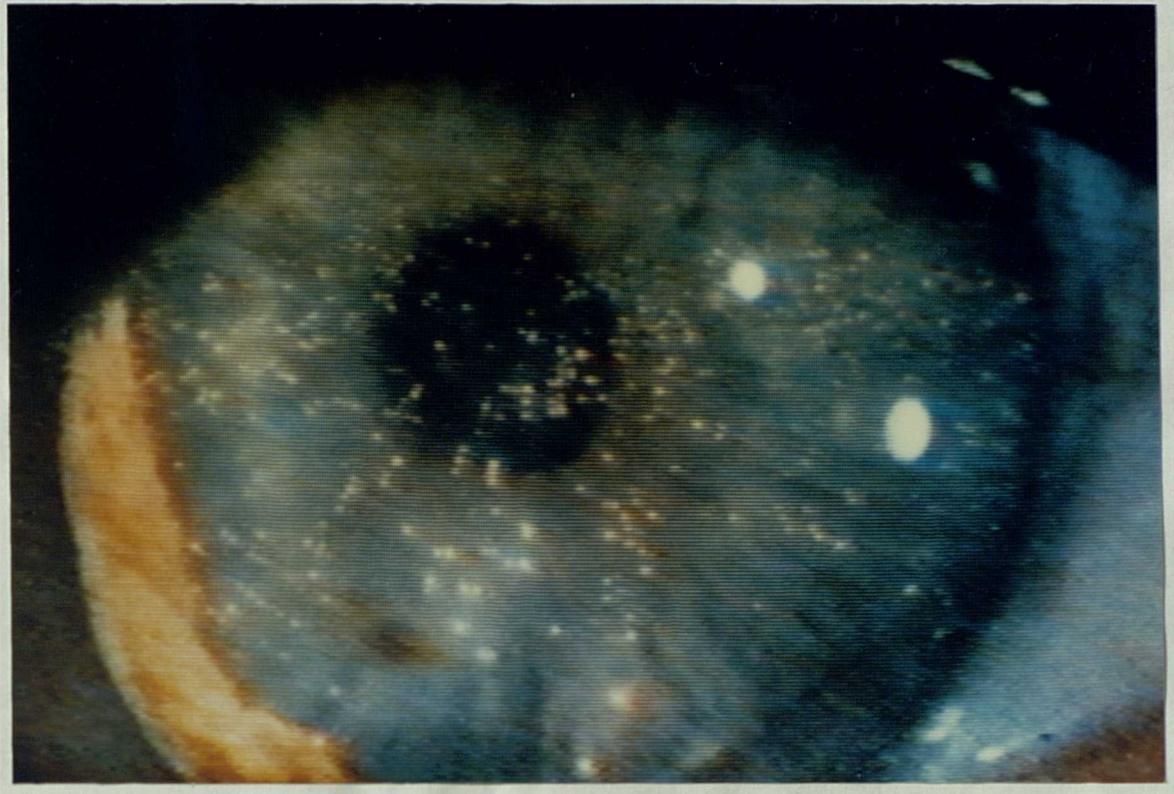

An opening night time shot in which a giant spurt of flame is reflected in an eye

b)



A space ship flys over once of the many Zigurats in Blade Runner

c)

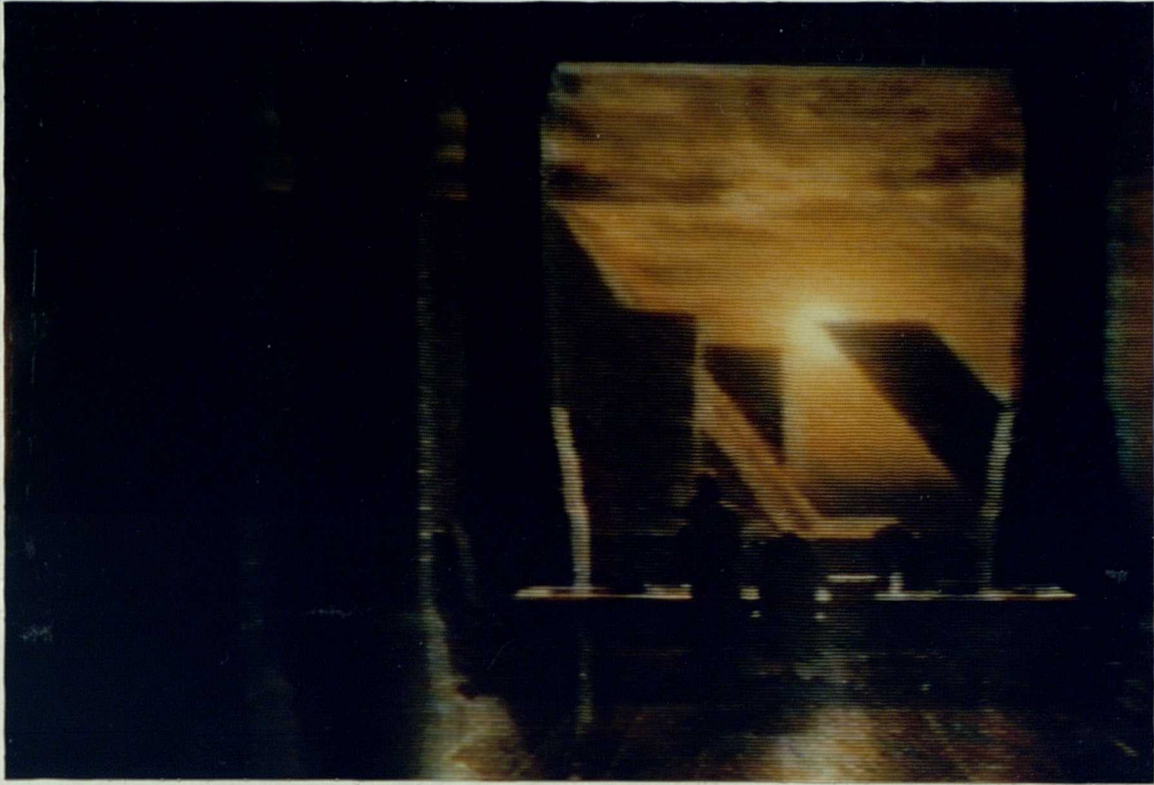

Inside the Tyrel Building. Note the quasi Egyptian and religious ambience

d)



A replicant owl. (Note its strange right eye)

e)



The replicant Pris dressed as a toy doll. (Decker is outlined to the right of picture)

f)



The giant Coca-Cola advertisement

g)



Roy's spirit is released in the form of a dove

h)



The final flight through the pastoral setting of fields and valleys



APPENDIX II

Stills from Trancers

(Dir. C. Band, Lexyen Productions, 1984)

a)



The emergency beacon

b)



A red tracer outline which occurs prior to the singe marks.  
c.f. Appendix II:(f)

c)



The sunken city of Lost Angels (sic. Atlantis)

d)



The ghostly image of Whistler

e)



Santa Claus at the North Pole

f)



A singe trace

g)



A bullet flies towards Leena in 'magic'/'sacred' time

h)

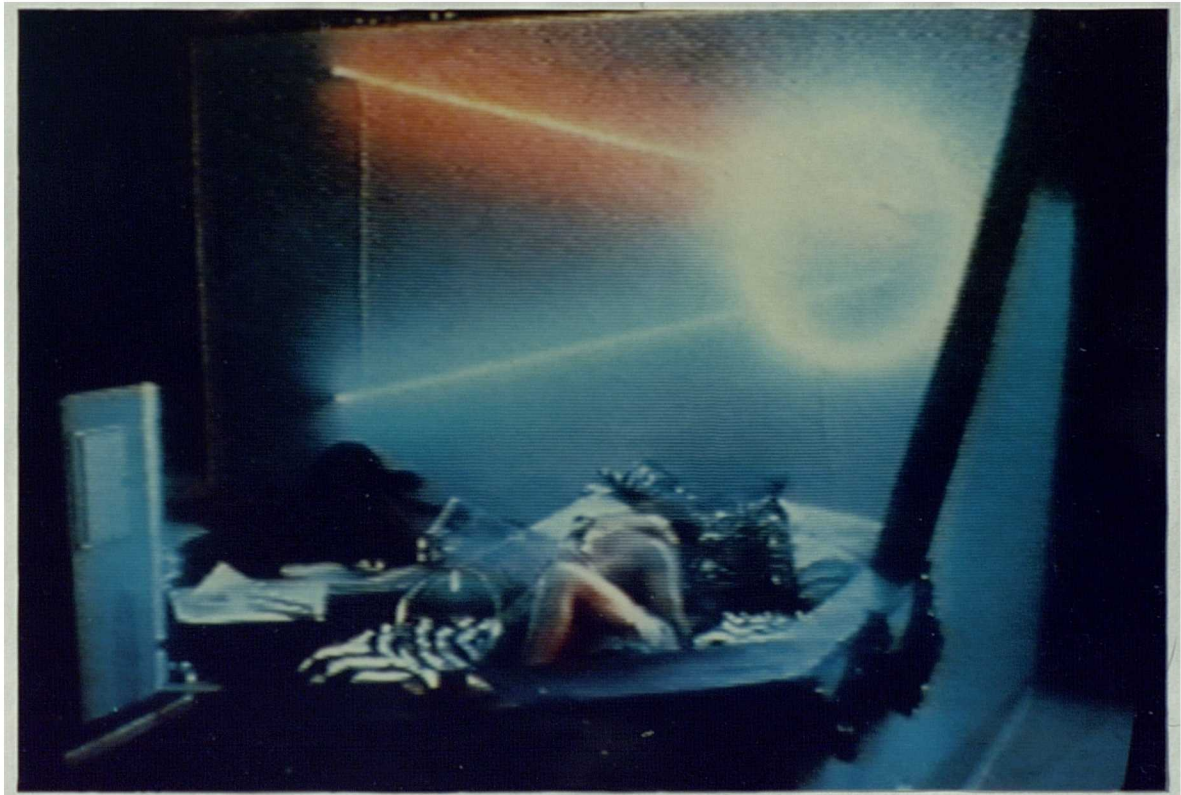

The apartment in Chinatown. Note the symbol of union over the bed

1)



Whistler attempts to trance Leena in Chinatown

j)



Whistler is sent back up the line

APPENDIX III

The Analytical Model and Its Central Guiding Questions

The Analytical Model and its Central Guiding Questions

	Archetypal Pattern	Mythologem
Archetype's Image	What archetypal patterns are revealed, how are they expressed, and what are their opposite patterns?	What is the main myth and what are its auxiliary myth themes?
Mythology	What are the mythological parallels to the uncovered pattern, how do these parallels inform as to the impetus of the central archetypal pattern?	What symbols are liberated in this myth, how do they relate to both the archetypal pattern and individuation process? What oppositions do they contain?
Individuation Process	What oppositions are being unified in the individuation process?	How do the myth themes relate to the individuation process?



---

This bibliography includes all works referred to in the text and notes. It also includes those uncited works which directly informed the composition of the text. No attempt is made to indicate more general intellectual debts.

---

Bibliography

Psychology, and Biographical Books on C. G. Jung

PSYCHOLOGY

- ADLER, G., Studies in Analytical Psychology, (London, 1948). This edition, (London, 1966).
- AUGER, J. A., 'Images of Endings', Journal of Analytical Psychology, Vol. 31: 1 (1986).
- BARKER, C. M., Healing in Depth, (London, 1972).
- BECK, J. S. and MOLISH, H. B., Rorschach's Test, (New York, 1945).
- BEEBE, J., 'The Father's Anima', In: The Father: Contemporary Jungian Perspectives. Edited, Samuels, A., (London, 1985).
- BENDERSON, A., 'An Archetypal Reading of Juliet of the Spirits', Quarterly Review of Film Studies, Vol. 4, Number 2.
- BERTINE, E., Jung's Contribution to our Time, (New York, 1967).
- BOWLBY, J., Child Care and the Growth of Love, (London, 1953).
- BROME, V., Jung, Man and Myth, (London, 1980).
- CAROTENUTO, A., The Vertical Labyrinth, (Toronto, 1985).
- COHEN, E. D., C. G. Jung and the Scientific Attitude, (New York, 1975).
- COX, D., Analytical Psychology, (London, 1973).
- DOURLEY, J. P., The Psyche as Sacrament, (Toronto, 1981).
- DRY, A., The Psychology of C. G. Jung: A Critical Interpretation, (London, 1961).
- EDINGER, E. F., The Creation of Consciousness: Jung's Myth for Modern Man, (Toronto, 1981).
- EDINGER, E. F., The Bible and the Psyche: Individuation Symbolism in the Old Testament, (Toronto, 1986).
- ERICKSON, E., Childhood and Society, (London, 1951).

- EVANS, C., Psychology: A Dictionary of Mind, Brain and Behaviour, (London, 1978).
- EVANS, R. I., Jung on Elementary Psychology, (London, 1979).
- FORDHAM, F., An Introduction to Jung's Psychology, (London, 1953).
- FORDHAM, M., Children as Individuals, (London, 1970).
- FORDHAM, M., New Developments in Analytical Psychology, (London, 1975).
- FORDHAM, M., The Self and Autism, (London, 1976).
- FREUD, S., The Psychopathology of Everyday Life, First English Translation, (London, 1914). This edition, translated Tyson, A., (London, 1975).
- FRIEDENBERG, E. Z., Laing, (London, 1973).
- FROMM, E., To Have or to be?, (London, 1979).
- FULLER, P., Art and Psychoanalysis, (London, 1980).
- GLOVER, E., Freud or Jung, (London, 1950).
- GOFFMAN, E., The Presentation of the Self in Everyday Life, (London, 1969).
- GOLDBRUNNER, J., Individuation, (London, 1955).
- GOODBREAD, J. H., The Dreambody Toolkit, (London, 1987).
- GORDON, R., 'Losing and Finding: The Location of Archetypal Experience', Journal of Analytical Psychology, Vol. 32: 2 (1985).
- GRAESBECK, G., 'The Archetype of the Wounded Healer', Journal of Analytical Psychology, Vol. 70: 2 (1975).
- GRANT, W. H., THOMPSON, M., and CLARKE, T. E., From Image to Likeness: A Jungian Path in the Gospel Journey, (New York, 1983).
- GREENFIELD, B., 'The Archetypal Masculine', In: The Father Contemporary Jungian Perspectives, Editor, Samuels, A., (London, 1985).
- HADFIELD, J. A., Dreams and Nightmares, (London, 1954).

- HALL, J. A., Jungian Dream Interpretation, (Toronto, 1983).
- HALL, J. A., The Jungian Experience: Analysis and Individuation, (Toronto, 1983).
- HANNAH, B., Jung His Life and Work, (London, 1976).
- HARDING, M. E., Psychic Energy: Its Source and Transformation, (Princeton, 1963). This edition, (Princeton, 1973).
- HILLMAN, J., Re-Visioning Psychology, (New York, 1975). This edition, (New York, 1977).
- HILLMAN, J., The Dream and the Underworld, (New York, 1979).
- HOBSON, R., 'The Archetypes of the Collective Unconscious', In: Analytical Psychology a Modern Science, Editor, Fordham, M., et al., (London, 1973).
- HOMES, P., Jung in Context, (Chicago, 1979).
- HORNEY, K., New Ways in Psychoanalysis, (London, 1939).
- HUMPHREY, N., Consciousness Regained, (Oxford, 1983).
- JACOBI, J., The Psychology of C. G. Jung, (London, 1969).
- JAFFÉ, A., Bilder und Symbole aus ETA Heffman's "Märchen der Goldener Topf, In: Gestaltungen des unbewussten, Editor, Jung, C. G., (Zurich, 1950).
- JAFFÉ, A. (Editor). C. G. Jung Word and Image, (Princeton, 1979).
- JAFFÉ, A., The Myth of Meaning in the Work of C. G. Jung, (Zurich, 1983).
- JASPERS, K., General Psychology, translated, Hoenig, J., and Hamilton, M. W., (Manchester, 1963). This edition, (London, 1974).
- JUNG, C. G., Collected Works of C. G. Jung, Edited, Read, H., Fordham, M., Adler, G., translated by Hull, R., (London).
- Vol. 1. Psychiatric Studies, (1957, 1970)
  2. Experimental Researches, (1973)
  3. The Psychogenesis of Mental Disease, (1960)

- Vol. 4. Freud and Psychoanalysis, (1961)
5. Symbols of Transformation, (1956, 1967)
6. Psychological Types, (1921)
7. Two Essays on Analytical Psychology, (1953, 1966)
8. The Structure and Dynamics of the Psyche, (1960, 1969)
- 9,I. The Archetypes and the Collective Unconscious, (1959)
- 9,II. Aion, (1951)
10. Civilisation in Transition, (1964)
11. Psychology and Religion: West and East, (1958, 1969)
12. Psychology and Alchemy, (1944)
13. Alchemical Studies, (1967)
14. Mysterium Coniunctionis, (1963, 1970)
15. The Spirit in Man, Art, and Literature, (1966)
16. The Practice of Psychotherapy, (1954, 1966)
17. The Development of Personality, (1954)
18. The Symbolic Life, (1977)
19. Bibliography of C. G. Jung's Writings
20. General Index to the Collected Works

Supplementary Vol. A., The Zofingia Lectures, edited McGuire, W., (London, 1983).

Seminar Papers, Vol. 1., Dream Analysis, edited McGuire, W., (London, 1984).

JUNG, C. G., Modern Man in Search of a Soul, translated by Dell, W. S., and Baynes, C. F., (London, 1933). This edition, (London, 1985).

JUNG, C. G., Basel Seminar, (Zurich, 1934).

JUNG, C. G., Memories, Dreams, Reflections, (London, 1963).

JUNG, C. G., (editor), Man and his Symbols, (London, 1964).

JUNG, C. G., Letters, (Princeton, 1973).

JUNG, C. G. and FREUD, S., The Freud/Jung Letters, (London, 1974). This edition, (London, 1979).

- JUNG, C. G., C. G. Jung Speaking: Interviews and Encounters, editor, McGuire, W., and Hull, R. F. C., (London, 1978).
- JUNG, E., and von FRANZ, M. L., The Grail Legend, (London, 1971).
- KEUTZER, L., 'Archetypes, Synchronicity and the Theory of Formative Causation', Journal of Analytical Psychology, Vol. 27: 3, (1982).
- LAING, R. D., The Divided Self, (Tavistock, 1960).
- LAKE, F., Clinical Theology: A Theological and Psychiatric Basis to Clinical Pastoral Care, (London, 1966).
- LAMBERT, K., 'Analytical Psychology and Development in Western Consciousness', Journal of Analytical Psychology, Vol. 22: 1, (1977).
- LEE, S. M., and HERBERT, M. (editors), Freud and Psychology, (London, 1970).
- MAIDENBAUM, J. 'The Scarlet Letter: a Contemplation of Symbol', Psychological Perspectives, Vol. 15: 2, (1984).
- MARCUSE, H., One Dimensional Man, (London, 1964).
- MARTIN, P. W., Experiment in Depth, (London, 1955).
- MATTOOM, A., Jungian Psychology in Perspective, (New York, 1981).
- MINDELL, A., The Dreambody in Relationship, (London, 1987).
- MOLLY, T. (editor), In the Wake of Jung, (London, 1983). This edition, (London, 1974).
- MORENO, A., Jung, Gods and Modern Man, (USA, 1970). This edition, (London, 1974).
- NEUMANN, E., The Origins and History of Consciousness, (Germany, 1949). This edition, (New York, 1973).
- NEUMANN, E., Amor and Psyche: The Psychic Development of the Feminine, (Princeton, 1956).
- O'NEIL, T. R., The Individuated Hobbit, (London, 1979).

- OSWALD, I., Sleep, (London, 1966).
- PERERA, S. B., The Scapegoat Complex: toward a mythology of shadow and guilt, (Toronto, 1986).
- PIAGET, J., A Child's Conception of the World, (London, 1923). This edition, (London, 1973).
- PROCHASHA, H., 'ARAS and Amplification', Journal of Analytical Psychology, Vol. 29: 2, (1984).
- PROGOFF, I., Jung's Psychology and its Social Meaning, (London, 1953).
- RIEFF, P., The Triumph of the Therapeutic, (London, 1966).
- RYCROFT, C., 'A Detective Story, Psychoanalytic Observations', Psychoanalytic Quarterly, Vol. 26, (1957).
- SAMUELS, A., (editor), The Father: Contemporary Jungian Perspectives, (London, 1985).
- SAMUELS, A., Jung and the Post Jungians, (London, 1985).
- SAMUELS, A., SHORTER, B., and PLANT, A., A Critical Dictionary of Jungian analysis, (London, 1986).
- SANFORD, J., The Invisible Partners, (New York, 1980).
- SCHNEIDER, M. D., 'The Theory and Practice of Movie Psychiatry', The American Journal of Psychiatry, Vol. 144, No. 8, (1987).
- SERRANO, M., Jung and Hermann Hesse: a record of two friendships, (London, 1971).
- SHORTER, B., An Image Darkly Forming: Women and Initiation, (London, 1987).
- SINGER, J., Boundaries of the Soul: The Practice of Jung's Psychology, (New York, 1972).
- SINGER, J., Androgeny: Towards a New Theory of Sexuality, (London, 1977).
- SKINNER, B. F., About Behaviourism, (New York, 1974).
- SKINNER, B. F., Beyond Freedom and Dignity, (New York, 1975).



- SKINNER, B. F., Reflections on Behaviourism and Society, (New Jersey, 1978).
- SKOGEMANN, P., 'Chuang Tzu and the Butterfly Dream', Journal of Analytical Psychology, Vol. 31: 1, (1986).
- SNIDER, C., 'C. G. Jung's Analytical Psychology and Literary Criticism', Psychocultural Review, Vol. 11, (1977).
- SPINKS, S., Psychology and Religion, (London, 1963).
- STAFFORD, B., 'An Analysis on Non-Symbolic Experience: The Mystic in Everyman', Imagination Cognition and Personality, Vol. 4: 2, (1984-85).
- STEELE, S. R., Freud and Jung: Conflicts of Interpretation, (London, 1982).
- STEIN, L., 'Introducing not Self', Journal of Analytical psychology, Vol. 12: 2, (1967).
- STERN, P., C. G. Jung: The Haunted Prophet, (New York, 1976).
- STORR, A., Jung, (London, 1973).
- STRACHAN, E., and STRACHAN, G., Freeing the Feminine, (Dunbar, 1985).
- SZASZ, T. S., The Myth of Mental Illness, (New York, 1961).
- TYRELL, G., The Personality of Man, (London, 1946).
- ULANOV, A., and ULANOV, B., The Witch and the Clown: Two Archetypes of Human Sexuality, (Illinois, 1987).
- Van der POST, L., Jung and the Story of our Time, (London, 1976).
- Von FRANZ, M. L., C. G. Jung: His Myth in our Time, (Germany, 1972). This edition, (London, 1975).
- WHITE, V., God and the Unconscious, (London, 1952).
- WHITE, V., Soul and Psyche, (London, 1960).
- WHITMONT, E. C., The Symbolic Quest - Basic Concepts in Analytical Psychology, (Princeton University, Princeton, 1978).
- WICKES, F., The Inner World of Choice, (New Jersey, 1976).

WINNICOTT, D. W., The Child, the Family and the Outside World, (London,  
. 1964).

Bibliography

Film Theory and Film History

FILM THEORY AND HISTORY

- ANDREW, D., Concepts in Film Theory, (Oxford, 1984).
- ARMOUR, R. A., Fritz Lang, (Boston, 1978).
- ARNHEIM, R., Film as Art, (London, 1958).
- BAUER, S., BOLTER, L., and HUNT, W., 'The Detective Film as Myth',  
American Imago a Psychoanalytical Journal for Culture,  
(1978).
- BAXTER, J., Hollywood in the Thirties, (New York, 1968).
- BORDWELL, D., Narration in the Fiction Film, (London, 1985).
- BORDWELL, D., and THOMPSON, K., Film Art, (New York, 1986).
- BRANSON, C., Howard Hawkes a Jungian Study, (Los Angeles, 1987).
- CARPENTER, E. C., Oh What a Blow that Phantom Gave Us, (London, 1976).
- CARRABINO, V., (Editor), The Power of Myth in Film - Selected Papers  
from the Second Annual Florida State University  
Conference on Literature and Film, (Tallahasse, 1980).
- CARROLL, J. M., Toward a Structural Psychology of the Cinema, (New York,  
1980).
- CAUGHIE, J., (Editor), Theories of Authorship: a reader, (London, 1981).
- CHANNAN, M., The Dream that Kicks, (London, 1980).
- CLARENS, G., Crime Movies, (London, 1980).
- CLIFTON, N. R., The Figure in Film, (London, 1983).
- DAVIS, B., The Thriller, (London, 1973).
- DAVIS, P., and NEVE, B., (Editors), Cinema, Politics and Society in  
America, (Manchester, 1981).
- EBERWEIN, P. T., Film and the Dream Screen, (Princeton, 1984).
- EVERSON, W., The Detective in Film, (New Jersey, 1972).

- FELL, J. L., Film and the Narrative Tradition, (Oklahoma, 1974).
- FINCH, C., and ROSENKRANTZ, L., Gone Hollywood, (London, 1979).
- FRIEDRICKSEN, D., 'Jung, Sign, Symbol, Film', Quarterly Review of Film Studies, Vol. 4: 2, (1979).
- FRIEDRICKSEN, D., 'Jung, Sign, Symbol, Film - Part Two', Quarterly Review of Film Studies, Vol. 5: 4, (1980).
- GABBARD, G., and GABBARD, K., 'Countertransference in the Movies', Psychoanalytic Review, Vol. 72: 1, (1985).
- GABREE, J., Gangsters: from Little Caesar to the Godfather, (New York, 1973).
- GEOTHALS, G. T., The TV Ritual: Worship at the Video Altar, (Boston, 1981).
- GORDON, A., 'Return of the Jedi: the end of the myth', Film Criticism, Vol. 8: 2, (1984).
- GOW, G., Hollywood in the Fifties, (New York, 1971).
- GRANT, B. K., Film Genre: Theory and Criticism, (Metuchen, 1977).
- GREGORY, C., 'Knight Without Meaning?', Sight and Sound, Summer (1973).
- HARDY, P., 'They Lived by Night', The Movie, Vol. 4: 30, (1982).
- HARDY, P., The Encyclopedia of Science Fiction Movies, (London, 1984).
- HAYLES, N., and KINDSKOPF, K., 'The Shadow of Violence', Journal of Popular Film and Television, Vol. 8: 2, (1980/1984).
- HEATH, S., Questions of Cinema, (London, 1981).
- HENDERSON, B., A Critique of Film Theory, (New York, 1980).
- HIGHAM, C., and GREENBERG, J., Hollywood in the Forties, (New York, 1968).
- HUSS, R., The Mindscapes of Art, (London, 1986).
- JARVIE, I. C., Towards a Sociology of the Cinema, (London, 1970).
- JARVIE, I. C., Philosophy of the Film, (New York, 1987).
- JENKINS, S., (Editor), Fritz Lang, (London, 1981).

- KAMINSKY, S. M., American Film Genres, (New York, 1974).
- KARPF, S. L., The Gangster Film 1930-1940, (New York, 1973).
- KAWIN, B. F., Mindscreen: Bergman, Godard and first-person film,  
(Princeton, 1978).
- KINNARD, R., and VITONE, R. J., The American Films of Michael Curtiz,  
(London, 1986).
- McARTHUR, G., Underworld USA, (London, 1972).
- MAY, J. R., and BIRD, M., (Editors), Religion in Film, (University of  
Tennessee, 1982).
- METZ, C., Film Language: a semiotics of the cinema. Translated, Taylor, M.,  
(New York, 1974).
- METZ, C., Psychoanalysis and Cinema: the imaginary signifier. Translated  
Britton, C., Williams, A., Brewster, B., Gazzetti, A.,  
(London, 1982).
- MEYERS, R., TV Detectives, (London, 1981).
- MONACO, J., 'The Big Sleep', Sight and Sound, Winter (1974-1975).
- MONACO, J., How to Read a Film, (New York, 1981).
- MONACO, P.; Cinema and Society, (New York, 1976).
- MONACO, P., 'Film as Myth and National Folk Law', In: The Power of Myth  
in Film, Editor, Carrabino, V., (Tallahasse, 1980).
- MUNSTERBERG, H., The Film a Psychological Study: the silent photoplay  
in 1916, (New York, 1970).
- NEALE, S., Genre, (London, 1980).
- NEWMAN, K., 'Trancers', Monthly Film Bulletin, February (1985).
- OFFENBACHER, E., 'Film as Transcendental Experience', Communications,  
Vol. 11: 3, (1985).
- OVERBY, D., 'In the Shadows', The Movie, Vol. 3: 30, (1982).
- PETRIC, V., (Editor), Film and Dreams: an approach to Bergman, (New York,  
1981).

- PLACE, J., 'Women in Film Noir', In: Women in Film Noir, Editor, Kaplan, E. A., (London, 1978).
- ROSENWEIG, S., Cassablanca and Other Major Films of Michael Curtiz, (Ann Arbour, 1982).
- ROSOW, E., Born to Loose: The Gangster Film in America, (Oxford, 1978).
- ROTH, L., 'Raiders of the Lost Archetype: The Quest and the Shadow', Studies in the Humanities, Vol. 10, June, (1983).
- RYBARK, D., 'Jedi and Jungian Forces', Psychological Perspectives, Vol. 14: 2, Fall, (1983).
- SAGE, L., 'Kojak and Co', Sight and Sound, Summer, (1975).
- SARIS, A., The Films of Josef von Sternberg, (New York, 1966).
- SCHATZ, T., Hollywood Genres, (New York, 1981).
- SHADOIAN, J., Dreams and Dead Ends: the American Gangster/Crime Film, (Cambridge, Mass., 1977).
- SHICHTMAN, M. B., 'Hollywood's New Western: The Grail Myth in Francis Ford Coppola's Apocalypse Now and John Boorman's Excalibur', Post Script Essays in Film and the Humanities, Vol. 4: 1, (1984).
- SILVER, A., and WARD, E., (Editors), Film Noir, (London, 1979).
- SKEENE, M. D., (Editor), Crime, Detective, Espionage, Mystery and Thriller Fiction and Film, (London, 1980).
- SLOTKIN, R., 'Prologue to a Study of Myth and Genre in American Movies', Prologue, Vol. 9, (1984).
- SOLOMON, S. J., The Film Idea, (New York, 1972).
- SOLOMON, S. J., Beyond Formula: American Film Genres, (New York, 1976).
- THOMPSON, D., 'Deadlier than the Male', The Movie, Vol. 3: 30, (1982).
- TUDOR, A., The Theories of Film, (London, 1974).
- TUSKA, J., Dark Cinema: American Film Noir in cultural perspective, (London, 1984).

TYLER, P., Sex Psyche Etcetera in the Film, (New York, 1969).

TYLER, P., The Magic and Myth of the Movies, (London, 1971).

WILLIAMS, C., (Editor), Realism and the Cinema, (London, 1980).

WILSON, G. M., Narration in Light, (Baltimore, 1986).

WOLFENSTEIN, M., and LEITES, N., Movies a Psychological Study,  
(Illinois, 1950).

WOLLEN, P., Signs and Meaning in the Cinema, (London, 1969).

WOLLEN, P., Readings and Writings: semiotic counter strategies,  
(London, 1982).



Bibliography

Mythology, Anthropology, and Comparative Religion

MYTHOLOGY, ANTHROPOLOGY, AND COMPARATIVE RELIGION

ALLCROFT, A. H., The Circle and the Cross, (London, 1927).

ALLEGRO, J., The Last Gods, (London, 1977). This edition, (London, 1978).

ASHE, G., The Virgin, (London, 1976).

BHAGAVAD GITA, THE, Translated, Mascaro, J., (Harmondsworth, 1967). This edition, (London, 1979).

BELL, R. E., A Dictionary of Classical Mythology, (California, 1982).

BIBLE, THE, New International Version, (London, 1979).

BOUQUET, A. C., Comparative Religion, (London, 1941). This edition, (London, 1962).

BRIGGS, K., A Dictionary of Fairies, (London, 1976).

BURTT, E. A., (Editor), The Teachings of the Compassionate Buddha, (New York, 1955). This edition, (New York, 1982).

CAMPBELL, J., The Hero with a Thousand Faces, (London, 1949). This edition, (London, 1968).

CAMPBELL, J., Myths to Live By, (London, 1973). This edition, (Glasgow, 1984).

CAMPBELL, J., Primitive Mythology, (London, 1959). This edition, (London, 1984).

CAMPBELL, J., Oriental Mythology, (London, 1973). This edition, (London, 1984).

CAMPBELL, J., Occidental Mythology, (London, 1970). This edition, (London, 1984).

CAMPBELL, J., Creative Mythology, (London, 1968). This edition, (London, 1984).

CARRABINO, V., (Editor), The Power of Myth in Literature and Film, (Florida, 1980).

CAUSSIN, N., De symbolica aegyptiorum sapientia polyhistor symbolicus electorum symbolorum et parabolorum historicum stromata. (Paris, 1618 and 1631).

- CAVENDISH, R., (Editor), Mythology: An Illustrated Encyclopedia,  
(London, 1980).
- CHARROUX, R., Lost Worlds: Scientific Secrets of the Ancients,  
(London, 1973).
- CHASE, R., Quest for Myth, (New York, 1949).
- CHETWYND, T., Dictionary for Dreamers, (London, 1974).
- CHETWYND, T., A Dictionary of Symbols, (London, 1982).
- CHEVALIER, J., and GHEERBRENT, A., Dictionnaire des Symboles, (France,  
1969). This edition, (France 1973-1974).
- COHN, J. M., and PHIPPS, J. F., The Common Experience, (London, 1979).
- COOPER, J. C., An Illustrated Encyclopedia of Traditional Symbols,  
(London, 1978).
- DHAMMAPANDA, Translated, Mascaro, J., (Harmondsworth, 1973).
- DIEHL, H., 'Into the Maze of Self: Protestant Transformations of the  
Images of the Labyrinth', The Journal of Mediaeval  
and Renaissance Studies, Vol. 16: 2, (1986).
- EGGELING, J., The Sacred Books of the East, Translated, (Oxford, 1882).
- ELIADE, M., The Myth of the Eternal Return, Translated Task, W. R.,  
(New York, 1954).
- ELIADE, M., Birth and Rebirth, (New York, 1958).
- ELIADE, M., Patterns in Comparative Religion, (New York, 1958).
- ELIADE, M., Myths, Dreams and Mysteries, (London, 1961).
- ELIADE, M., From Primitives to Zen, (London, 1967). This edition,  
(London, 1983).
- ELIADE, M., Occultism, Witchcraft and Cultural Fashions, (Chicago, 1979).
- EVANS-PRITCHARD, E. E., Theories of Primitive Religion, (Oxford, 1965).
- FARNELL, L. R., Greek Hero Cults and Ideas of Immortality, (Oxford, 1921).

- FERGUSON, J., An Encyclopedia of Mysticism and the Mystery Religions,  
(London, 1976).
- FRANKFORT, H. W., Before Philosophy, (London, 1949).
- FREEDMAN, D. N., and GRANT, M. R., The Secret Sayings of Jesus,  
(London, 1960).
- GILCHRIST, C., Alchemy, (London, 1984).
- GILGAMESH, THE EPIC OF, Translated, Sanders, N. K., (Harmondsworth, 1960).  
This edition, (London, 1978).
- GRAVES, R., The Greek Myths, (London, 1955).
- GRAVES, R., The White Goddess, (London, 1977).
- GUENTHER, H. V., Buddhist Philosophy in Theory and Practice, (London, 1971).
- GULPILIL, Gulpilil's Stories of the Dream Time, completed by Rule, H.,  
and Goodman, S., (Sydney, 1979).
- GYATSO, T., The Kalachakra Tontia: a rite of initiation, Translated,  
Hopkins, J., (London, 1985).
- HANSEN, C., Witchcraft at Salem, (Sydney, 1970).
- HINDU SCRIPTURES, Translated Zachner, R. C., (London, 1931). This  
edition, (London, 1982).
- HIRIYANNA, M., Essentials of Indian Philosophy, (London, 1949).
- HOLMYARD, E. J., Alchemy, (London, 1957).
- HOOKE, S. H., Middle Eastern Mythology, (London, 1963).
- HOPE-MONCRIEF, A. R., Classic Myth and Legend, The Gresham Publishing  
Company. (No date given).
- HUGHES, P., Witchcraft, (London, 1952).
- JAMES, W., The Worship of the Sky God, (London, 1963).
- KIRK, J. S., Myth: its Meaning and Function in Ancient and Other Cultures,  
(Los Angeles, 1970).

- LAWS OF MANU, THE, In: Sacred Books of the East, Translated Buhler, G., (Oxford, 1886).
- LECA, A. P., The Cult of the Immortal, (London, 1980).
- LEMPRIERE, J., Lempriere's Classical Dictionary. This edition, (London, 1984).
- LEVI-STRAUSS, Totemism, Translated Needham, R., (London, 1963).
- LEVI-STRAUSS, Mythologiques: Le Cru et le Cuit, (Paris, 1964).
- MICHELL, J., City of Revelation, (London, 1972).
- O'BRIAN, E., Varieties of Mystical Experience, (New York, 1965).
- OVID, Metamorphoses, Translated Innes M. M., (Harmondsworth, 1955). This edition, (London, 1984).
- PINSENT, J., Myths and Legends of Ancient Greece, (London, 1969).
- PIRSIG, R., Zen and the Art of Motorcycle Maintenance, (London, 1974).
- RADFORD, E., and RADFORD, M. A., Encyclopedia of Superstitions, (London, 1948).
- RADICE, B., (Editor), Early Christian Writings, (London, 1968).
- RIG VEDA, In: Hymns of the Rig Veda, IV, Translated Griffiths, R. T. H., (Benores, 1892).
- RIEMSH, M., Rad und Ring als Symbole der unterweit, (Stuttgart, 1962).
- ROBINSON, R., Aboriginal Myths and Legends, (Melbourne, 1966).
- RUYSBROECK, J., The Adornment of the Spiritual Marriage. The Book of the Supreme Truth. The Sparkling Stone, Translated Wynshenk, C. A., (London, 1916).
- SELTMAN, C., The Twelve Olympians, (London, 1952).
- SEZNEC, J., The Survival of the Pagan Gods, Translated Sessions, B. F., (Princeton, 1953).
- SHAKESPEARE, W., King Lear, The Arden Shakespeare, (London, 1964).

- SMART, N., The Religious Experience of Mankind, (New York, 1968).  
This edition, (London, 1977).
- SPEISER, E. A., Ancient Near Eastern Texts, translated, (Princeton, 1950).
- STACE, T. W., The Teachings of the Mystics, (New York, 1960).
- STEINER, R., Christianity and Occult Mysteries of Antiquity, translated  
Frommer, E. A., Heff, G., and Kandler, R., (New York, 1964).
- THEODORE de BARRY, W., The Buddhist Tradition, (New York, 1969). This  
edition, (New York, 1972).
- TEREA, N., The Heart of Buddhist Meditation, (London, 1962).
- THOMPSON, F., Poetical Works, editor, Weynell, W., (London, 1913).
- THOMPSON, I. T., The Time Falling Bodies Take to Light: Mythology,  
Sexuality and the Origins of Culture, (London, 1981).
- TSU, L., Tao te Ching, translated Feng, G. F. and English, J., (London,  
1973). This edition, (London, 1974).
- UPANISHADS, Translated Mascaro, J., (Harmondsworth, 1965). This edition,  
(London, 1985).
- Van GENNEP, A., The Rites of Passage, translated by Vizedons, M. B., and  
Caffee, G. L., (London, 1960). This edition, (London,  
1977).
- VIRES, A., Dictionary of Symbols and Imagery, (Amsterdam, 1974).
- VIRGIL, The Aeneid, translated Jackson-Knight, W. F., (London, 1956).  
This edition, (London, 1976).
- WARNER, M., All Alone of her Sex: The Myth and Cult of the Virgin Mary,  
(London, 1976).
- WARNER, R., Encyclopedia of World Mythology, (London, 1970).
- WOOD, E., Yoga, (London, 1959).
- ZAEHNER, R. C., Hinduism, (New York, 1962).

ZIMMER, H., Myths and Symbols in Indian Art and Civilisation, edited  
Campbell, J., (Princeton, 1946). This edition,  
(Princeton, 1963).

Bibliography

Cultural and Literary Criticism, Literature and Science



CULTURAL AND LITERARY CRITICISM, LITERATURE AND SCIENCE

- ADAMS, V., Crime, (Nederlands, 1978).
- ANDREWS, A., The Greeks, (London, 1967).
- AUDEN, W., The Dyer's Hand, (London, 1948).
- BARTHES, R., Mythologies, Translated Lavers, A., (London, 1973).
- BARTHES, R., Image Music Text, Translated Heath, S., (London, 1977).
- BATESON, G., Steps to an Ecology of the Mind, (London, 1973).
- BATESON, G., Mind and Nature, (London, 1979).
- BLAKE, W., The Complete Writings of William Blake, Editor, Keynes, G.,  
(London, 1966).
- BRONOWSKI, J., and MAZLISH, B., The Western Intellectual Tradition,  
(London, 1960).
- CAIRNES, D., The Image of God in Man, (London, 1973).
- CAPRA, F., The Turning Point, (London, 1982). This edition, (London, 1984).
- CARRELL, A., Man the Unknown, (London, 1935).
- COLLINS, Encyclopedia, (London, 1979).
- CORBISHLEY, T., The Spirituality of Teilhard de Chardin, (London, 1971).
- COTTRELL, L., Life Under the Pharaohs, (London, 1954).
- EBERLING, G., Luther, (London, 1970).
- FONTANA, Fontana Dictionary of Modern Thought, (London, 1971). This  
edition, (London, 1983).
- GOULD, S. J., Ontogeny and Phylogeny, (London, 1977).
- GROSSVOGEL, D. I., Mystery and its Fictions: From Oedipus to Agatha  
Christie, (Baltimore, 1979).
- HAINING, P., The Art of Mystery and Detective Stories, (London, 1983).
- HEISENBERG, W., Der Teil und der Ganze, (Munchen, 1969).
- HERACLITUS, Greek Religious Thought, Translated Cornford, (London, 1923).

- HERACLITUS, Ancilla to the Pre-Socratic Philosophers, translated  
Freeman, K., (Oxford, 1948).
- HERACLITUS, Heraclitus: Greek Text with a Short Commentary, translated  
Marrovitch, M., (Los Andes University Press, 1967).
- HUXLEY, J., Evolution, (London, 1942).
- KANT, I., Critique of Pure Reason, translated Smith, N. K., (London, 1979).
- KEE, A., The Way of Transcendence, (London, 1972).
- KEETING, H. R. F., (editor), Crime Writers: Reflections on Crime Fiction,  
(London, 1978).
- KNIGHT, S., Form and Ideology in Crime Fiction, (London, 1980).
- LEIBNIZ, G., Nouveaux Essais sur l'Entendement Humain, translated and  
edited Remnant, P., and Bennett, J., (Cambridge, 1981).
- LELLO, S. R., Revelations, Glimpses of Reality, (London, 1985).
- LEWIS, C. S., The Discarded Image, (Cambridge, 1964).
- MOST, G., and STOWE, W. W., Poetics of Murder: Detective Fiction and  
Literary Theory, (New York, 1983).
- PALMER, J., Thrillers: Genesis and Structure of a Popular Genre,  
(London, 1978).
- PLATO, Timeaus and Critias, translated Bury, Rev. R. G., (London, 1966).
- ROBBE-GRILLET, A., The Erasers, (London, 1964).
- ROBBE-GRILLET, A., Into the Labyrinth, (London, 1978).
- ROOKMASTER, H. R., Modern Art and the Death of a Culture, (London, 1970).
- SHELDRAKE, R., A New Science of Life, (London, 1981). This edition,  
(London, 1984).
- SHELDRAKE, R., Need Biology be Godless?, Centre Space, Occasional Paper,  
Number 3, June (1984).
- SHELDRAKE, R., The Presence of the Past, (London, 1988).

- SMITH, M., The Theory of Evolution. (London, 1958). This edition,  
(London, 1966).
- SYMONS, J., Bloody Murder, (London, 1972).
- TERTULLIAN, De Anima 55, Ante-Nicene Christian Library, editor Roberts, A.,  
and Donaldson, T., (Edinburgh, 1870).
- THOMAS, K., Religion and the Decline of Magic, (London, 1971). This  
edition, (London, 1984).
- TILLICH, P., The Dynamics of Faith, (New York, 1956).
- TODOROV, T., The Fantastic, translated Howard, R., (London, 1973).
- TODOROV, T., The Poetics of Prose, translated Howard, R., (London, 1977).
- WALKER, K., The Diagnosis of Man, (London, 1962).
- WEBER, M., The Sociology of Religion, (London, 1963).
- WINKS, R. W. (Editor), Detective Fiction, (New Jersey, 1980).

Filmography

FILMOGRAPHYThe Blue Angel (UFA, Paramount, 1930)

Director,	Joesf von Sternberg
Producer,	Erich Pommer
Screenplay,	Carl Zuckmayer, Karl Vollmoler and Robert Liebmann
Story,	Professor Unrat, by Heinrich Mann
Photography,	Gunter Rittan, Hans Schneeberger
Art Director,	Otto Hunte, Emile Hasler
Sound Engineer,	Fritz Thiery
Editors,	S. K. Winston (English Version), Walter Idee (German Version)
Music,	Friedrich Hollander
Principal Cast,	Emil Jannings (Professor Immanuel Rath), Marlene Dietrich (Lola Lola), Kurt Gerron (Kiepert), Rosa Valetti (Guste), Hans Albers (Mazeppa), Reinhold Bernt (Clown)
Running Time,	109 mins.

King Kong (RKO Radio Pictures, 1933)

Director,	Merien C. Cooper and Ernst B. Shoodsack	
Producer,	David O. Selznick	
Editor,	Ted Cheesman	
Photographer,	Eddie Linden	
Screenplay,	James Creelman, Ruth Rose	
Music,	Max Steiner	
Key Actors,	Fay Wray, Bruce Cabot, Sam Hardy, Steve Clemento,	Robert Armstrong, Frank Reicher, Nobele Johnson, James Flavin
Running Time,	100 mins.	

The Kennel Murder Case (Warner Brothers, 1933)

Director, Michael Curtiz  
 Producer, Robert Presnell  
 Screenplay, Robert N. Lee, Peter Milne  
 Photographer, William Reese  
 Art Direction, Jack Okey  
 Editor, Harold McLarnin

Principal Cast, William Powell (Philo Vance), Mary Astor (Hilda Lake), Eugene Pallette (Heath), Ralph Morgan (Raymode Wrede), Helen Vinson (Doris Delafield), Etienne Giradote (Daremund)

Running Time, 73 mins

The Devil is a Woman (Paramount, 1935)

Director, Joesf von Sternberg  
 Screenplay, John Dos Passos, S. K. Winston  
 Photography, Joesf von Sternberg  
 Art Direction, Hans Drier  
 Music, Ralph Rainger, Andres Setara  
 Editor, Sam Winston

Principal Cast, Marlene Dietrich (Concha Perez), Lional Atwill (Don Pascal), Cesar Romero (Antonio Galvan), Edward Everett Horton (Don Paquito), Alison Skipworth (Senora Perez), Don Alvarado (Morenito), Morgan Wallace (Dr Mendez)

Running Time, 85 mins.

Double Indemnity (Paramount, 1944)

Director, Billy Wilder  
 Cinematographer, John Seitz  
 Art Director, Hans Dreir, Hal Pereira  
 Music Supervisor, Miklas Rozsa  
 Editor, Doane Harrison  
 Screenplay, Billy Wilder, Raymond Chandler. From the novel by James M. Caine

Principal Cast, Fred MacMurray (Walter Neff), Barbara Stanwyck (Mrs Diedrickson), Edward G Robinson (Mr Keys)

Running Time, 104 mins.

Murder My Sweet aka Farewell My Lovely (RKO, 1944)

Director, Edward Dmytryk  
 Producer, Adrian Scott  
 Screenplay, John Paxton  
 Story, Farewell My Lovely by Raymond Chandler  
 Director of Photography, Harry J Wild  
 Music, Roy Webb  
 Art Directors, Albert S. D'Agostino, Carroll Clark  
 Editor, Joseph Noreiga

Principal Cast, Dick Powell (Philip Marlowe), Claire Trevor (Velma/Mrs Grayle), Anne Shirley (Anne), Otto Kruger (Amthor), Mike Mazurki (Moose Malloy), Miles Mander (Mrs Grayle), Douglas Walton (Marrot), Don Douglas (It Randell), Rolfe Harolde (Dr Sonderborg), Ester Howard (Mrs Florian)

The Woman in the Window (RKO, 1944)

Director, Fritz Lang  
 Producer, Nunally Johnson  
 Screenplay, Nunally Johnson  
 Story, Once off Guard, J. H. Wallis  
 Photography, Milton Krasner  
 Special Effects, Vernon Walker  
 Art Direction, Duncan Cranmer  
 Music, Arthur Lang  
 Editor, Marjorie Johnson

Principal Cast, Edward G. Robinson (Richard Wanley), Joan Bennet (Alice), Raymond Massey (District Attorney), Dan Duryea (Blackmailer), Edmond Breon (Dr Barkstone), Thomas E. Jackson (Inspector Jackson)

Running Time, 99 mins.

Crossfire (RKO, 1947)

Director,	Edward Dmytryk
Producer,	Adrian Scott
Cinematographer,	J. Roy Hunt
Art Director,	Albert S. D'Agostino, Alfred Herman
Music,	Roy Webb
Editor,	Harry Gerstad
Screenplay,	John Paxton
Story,	<u>The Brick Fox Hole</u> , Richard Brooks
Special Effects,	Russel A. Cully

Principal Cast,	Robert Young (Finlay), Robert Mitchum (Keeley), Robert Ryan (Montgomery), Gloria Graham (Ginny), Richard Powers (The Detective), Sam Levene (Samuels), George Cooper (Mitchell)
-----------------	--

Running Time,	86 mins.
---------------	----------

The High Window aka The Basher Dubloon (Twentieth Century Fox, 1947)

Director,	John Brahm
Producer,	Robert Bassler
Screenplay,	Dorothy Hannah
Story,	<u>The High Window</u> , Raymond Chandler
Director of Photography,	Lloyd Ahern
Music,	David Buttolph
Art Directors,	James Basevi, Richard Irvine
Editor,	Harry Reynolds

Principal Cast,	George Montgomery(Philip Marlowe), Nancy Guild (Merle Davis), Conrad Janis (Leslie Murdoch), Roy Roberts (Lt. Breeze), Fritz Kortner (Vannier), Florence Bates (Mrs Murdoch), Marvine Miller (Blair), Houseley Stevenson (Morningstar), Bob Adler (Sgt. Spangler)
-----------------	--

Running Time,	72 mins.
---------------	----------



Lady in the Lake (MGM, 1947)

Director,	Robert Montgomery
Producer,	George Haight
Screenplay,	Steve Fisher
Story,	Raymond Chandler
Photography,	Paul C. Vogel
Special Effects,	A. Arnold Gillespie
Music,	David Snell
Art Directors,	Cedric Gibbons, Preston Ames
Editor,	Gene Ruggiero

Principal Cast,	Robert Montgomery (Philip Marlowe), Lloyd Nolan (Lt. De Garmon), Audry Trotter (Adrienne Fromsett), Tom Tully (Capt. Kane), Leon Ames (Derance Kingsby), Jayne Meadows (Mildred Haveland), Morris Ankrum (Eugene Grayson)
-----------------	---

Running Time,	105 mins.
---------------	-----------

Detective Story (Paramount, 1951)

Director,	William Wyler
Producer,	William Wyler
Associate Producers,	Robert Wyler, Lester Koenig
Cinematographer,	Lee Garmes
Art Director,	Hal Pereira, Earl Hendrick
Editor,	Robert Swink
Screenplay,	Philip Yordan, Robert Wyler
Story,	Sidney Kingsley

Key Actors:	Kirk Douglas, William Bendix, George MacCready, Gladys George, Lee Grant, Frank Faylen.	Eleanor Parker, Cathy O'Donnell, Horace McMahon, Joseph Wiseman, Gerald Mohr,
-------------	--	---

Running Time,	103 mins.
---------------	-----------

Sleuth (Fox Rank, 1972)

Director, Joseph L. Mankiewicz  
 Executive Producer, Edgar J. Sherick  
 Photographer, Oswald Morris  
 Screenplay, Anthony Shaffer  
 Editor, Richard Marden

Principal Cast, Lawrence Olivier (Andrew Wyke), Michael Caine (Milo Tindle), [Alec Cawthorne (Inspector Doppler)], Margo Channing (Marguerite), John Mathews (Det. Sgt. Tarrant), Teddy Martin (P. C. Higgs)

Running Time, 139 mins.

Equus (United Artists, 1977)

Director, Sidney Lumet  
 Producer, Elliott Kastner  
 Editor, John Victor Smith  
 Design, Tony Walton  
 Photographer, Oswald Morris  
 Screenplay, Peter Shaffer

Principal Cast, Richard Burton (Martin Dysart), Peter Firth (Alan Strang), Colin Blakely (Frank Strang), Joan Plowright (Dora Strang), Harry Andrews (Harry Dalton), Eileen Atkins (Hester Solomon), Jenny Agutter (Jill Mason)

Running Time, 137 mins.

Star Wars (Twentieth Century Fox, 1977)

Director, George Lucas  
 Producer, Gary Kurtz  
 Photographer, Gilbert Taylor  
 Screenplay, George Lucas  
 Special Effects Supervisor, John Dykstra, Industrial Light and Magic  
 Editors, Paul Hirsh, Marcia Lucas, Richard Chew  
 Music, John Williams

Principal Cast, Mark Hamill (Luke Skywalker), Harrison Ford (Hans Solo), Carrie Fisher (Princess Leia Organa), Peter Cushing (Grand Moff Tarkin, Governor of Imperial Outland Regions), Alec Guinness (Ben [Obi Wan] Kenobi), Antony Daniels (See Threepio [C-3PO]), Kenny Baker (Artoo-Detoo [R2-D2]), Peter Mayhew (Chewbacca), David Prowse (Lord Darth Vader)

Running Time, 121 mins.

Star Trek the Motion Picture (Paramount, 1979)

Director,	Robert Wise
Producer,	Gene Roddenberry
Editor,	Todd Ramsay
Photographer,	Richard H. Kline, Richard Yuricich
Screenplay,	Harold Livingstone
Special Effects,	Douglas Trumbull
Principal Cast,	William Shatner (Admiral James T. Kirk), Leonard Nimoy (Mr Spock), De Forrest Kelley (Dr Leonard "Bones" McCoy), James Doohan (Engineering Officer Montgomery "Scotty" Scott), George Takei (Helmsman Sulu), Majel Barrett (Dr Christine Chapel), Walter Koenig (Chekov), Nichelle Nichols (Communications Officer Uhura)
Running Time,	132 mins.

Raging Bull (United Artists, 1980)

Director,	Martin Scorsese
Producer,	Irwin Winkler, Robert Shartoff
Editor,	Thelma Schoonmaker
Photographer,	Michael Chapman
Screenplay,	Paul Schraeder, Mardik Martin
Design,	Gene Rudolf
Principal Cast,	Robert de Niro (Jake La Motta), Cathy Moriarty (Vickie La Motta), Joe Pesci (Joey La Motta), Frank Vincent (Salvy), Nicholas Colasanto (Tommy Como), Theresa Salandra (Lenore), Mario Gallo (Mario).
Running Time,	129 mins.

Blade Runner (Columbia, 1982)

Director,	Ridley Scott
Producer,	Michael Deeley
Photographer,	Jordan Cronenweth
Screenplay,	Hampton Frencher, David Peoples
Story,	<u>Do Androids Dream Electric Sheep?</u> , Philip K. Dick
Special Effects Supervisor,	Douglas Trumbull, Richard Yuricich, David Dryer
Principal Designer,	Lawrence G. Paull
Music,	Vangelis
Editor,	Terry Rawlings
Principal Cast,	Harrison Ford (Rick Decker), Rutger Hauer (Roy Batty), Seon Young (Rachel), Edward James Olmos (Gaf), M. Emmet Walsh (Capt. Bryant), Daryl Hannah (Pris), William Sanderson (J. F. Sabastian), Brian James (Leon), Joe Turkel (Dr Tryell), Joanna Cassidy (Zhora)
Running Time,	102 mins.

C.H.U.D. (New World Pictures, Bonime Productions, 1984)

Director,	Douglas Cheek
Producer,	Andrew Bonime
Adaptation,	Parnell Hall
Director of Photography,	Peter Stein
Story,	Shephard Abbott
Editor,	Claire Simpson
Music,	Cooper Hughes
Design,	William Bilowit
Principal Cast,	Laurie Mattas (Flora Bosch), John Herd (George Cooper), Kim Greist (Laurin), Brenda Currin (Francine), Justin Hall (Justin), Christopher Curry (Capt. Bosh), Cordis Hurd (Banderson), Eddie Jones (Chief O'Brian), Daniel Stern (The Reverend)
Running Time,	87 mins.

The Terminator (Orion, 1984)

Director, James Cameron  
 Executive Producer, John Aly, Derek Gibson  
 Editor, Mark Goldblatt  
 Art Director, George Costello  
 Photographer, Adam Greenberg  
 Screenplay, James Cameron, Gale Anne Hurd  
 Special Effects, Fantasy II Film Effects, (Production Supervisor, Leslie Huntley)

Principal Cast, Arnold Schwarzenegger (Terminator), Michael Biehn (Kyle Reese), Linda Hamilton (Sara Conner), Paul Winfield (Traxler), Lance Henriksen (Vukovich), Rich Rossovich (Matt), Bess Motta (Ginger), Earl Boen (Silberman)

Running Time, 107 mins.

Tightrope (Warner Brothers, 1984)

Director, Richard Tuggle  
 Producer, Clint Eastwood, Fritz Manes  
 Director of Photography, Bruce Surtees  
 Editor, Joel Cox  
 Music, Lennie Niehaus  
 Design, Edward Carfagno  
 Written by, Richard Tuggle

Principal Cast, Clint Eastwood (Wes Bloch), Dan Hedaya (Detective Moligan), Jennifer Beck (Penny Bloch), Rebecca Perle (Becky Jacklin), Randi Brooks (Janie Cory), Margaret Howell (Judy Harper), Genevieve Bujold (Beryl Thibodeaux), Alison Eastwood (Amanda Bloch), Marco St John (Leander Rolfe), Regina Richardson (Santa), Jamie Rose (Melanie Siber)

Running Time, 110 mins.

Trancers (Lexyen productions. An Empire Pictures Presentation, 1984)

Director,	Charles Band
Executive Producer,	Peter Manoogian, Brad Arensman
Producer,	Charles Band
Cinematographer,	Mac Ahlberg
Musical Supervisor,	Richard Band
Music,	Mark Ryder, Phil Davies
Screenplay,	Danny Bilson, Paul De Meo
Special Effects,	John Buechler, Mechanical and Makeup Imageries
Designer,	Jeff Staggs

Principal Cast,	Tim Thomerson (Jack Deth), Helen Hunt (Leena), Michael Stefani (Martin Whistler), Art De Fleur (McNulty), Telma Hopkins (Engineer Raines), Richard Herd (Chairman Spencer), Anne Seymore (Chairman Ashe), Miguel Fernandez (Officer Lopez), Biff Manard (Hap Ashby), Pete Schrum (Santa Claus), Barbera Perry (Mrs Santa Claus), Brad Logan (Bull), Minnie Lindsay ("Mom"), Richard Erdman (Drunken Wise Old Man), Wiley Harker (Dapper Old Man), Allyson Croft (Baby McNulty), Michael McGrady (Chris Lavery), Edward McLarty (Jerry the Punk), Don Ross (Security Guard), Michael Heldebrandt (Boy with Santa), Kim Shepard (Newswoman), Steve "O" Jenson, Nicky Beat, Tony Malone, Lantza Kranzt (The Buttheads)
-----------------	---

Running Time,	76 mins.
---------------	----------

2010 (MGM, UA, 1984)

Director,	Peter Hyams
Producer,	Peter Hyams
Editor,	James Mitchell, Mia Goldman
Design,	Albert Brenner
Photographer,	Peter Hyams
Screenplay,	Peter Hyams
Visual Effects Supervisor,	Richard Edlund, George Jensen

Principal Cast,	Roy Schneider (Dr Heywood Floyd), John Lithgow (Walter Curnow), Helen Mirren (Tanya Kirbuk), Bob Baluban (Dr R. Chandra), Keir Dulla (David Bowman), Douglas Rain (HAL 9000)
-----------------	---

Running Time,	116 mins.
---------------	-----------

Big Trouble in Little China (Twentieth Century Fox, 1986)

Director,	John Carpenter
Producer,	Larry J. Franco
Adaptation,	W. D. Richter
Director of Photography,	Dean Cundey
Written by,	Gray Goldman, David Z. Weinstein
Executive Producers,	Paul Monash, Keith Barish
Visual Effects,	Richard Edlund
Music,	John Carpenter, Alan Howarth
Principal Cast,	Kurt Russell(Jack Burton), Kim Cattrall (Gracie Law), Dennis Dun (Wang Chi), James Hong (Lo Pan), Victor Wong (Egg Shen), Kate Burton (Margo)
Running Time,	97 mins.