

THE ENERGETICS OF FORAGING IN
WADING BIRDS (CHARADRII)

A thesis submitted to the University of Stirling
for the degree of
Doctor of Philosophy

Jonathan Roger Speakman

June 1984

Department of Biological Sciences

SUMMARY OF CONTENTS

Contents

Abstract

Acknowledgements

Introduction

General Introduction

The foraging model

Materials and Methods

Selection of species, study sites and study periods

Model parameters

Model tests

Results

Model parameters

Model predictions and tests

Discussion

Model parameters

Model tests and general discussion

References

Appendix

CONTENTS

| | <u>Page</u> |
|---|-------------|
| <u>Abstract</u> | |
| <u>Acknowledgements</u> | |
| <u>Chapter One - Introduction</u> | 1 |
| <u>1 1 General Introduction</u> | 1 |
| <u>1 2 The foraging model</u> | 7 |
| (a) Rationale | 8 |
| (b) Search speed | 8 |
| (c) Search path angularity | 17 |
| (d) Diet choice and search strategy | 17 |
| (e) Relaxation of random encounter constraint | 21 |
| <u>Chapter Two - Materials and Methods</u> | |
| <u>PART ONE - Selection of study species, study sites and study periods</u> | 24 |
| <u>2 1 Selection of study species</u> | 24 |
| <u>2 2 Selection of study sites</u> | 25 |
| 2.2.1 Details of study sites | 25 |
| (a) Skinflats, Kincardine Bridge | 25 |
| (b) Culross, Longannet | 25 |
| (c) Culross, Old Pier | 25 |
| <u>2.3 Study periods</u> | 25 |
| <u>2 4 Statistics</u> | 26 |

| | <u>Page</u> |
|--|-------------|
| <u>PART TWO - Model parameters</u> | 26 |
| <u>2 5</u> <u>Prey density</u> | 26 |
| (a) Redshank prey | 26 |
| (b) Oystercatcher prey | 27 |
| <u>2 6</u> <u>Prey availability</u> | 27 |
| (a) Definition of availability | 27 |
| (i) Visual searching by Redshank | |
| (ii) Reliability test of surface cues | |
| (iii) Tactile searching by Redshank | |
| (iv) Oystercatcher searching | |
| (b) Measurement of availability | 29 |
| (i) Visual searching by Redshank | |
| (ii) Tactile searching by Redshank | |
| (iii) Oystercatcher searching | |
| <u>2 7</u> <u>Foraging path width</u> | 30 |
| (a) Direct estimate - Redshank | 31 |
| (b) Indirect estimate - Redshank | 31 |
| (c) Direct estimate - Oystercatcher | 32 |
| <u>2 8</u> <u>Prey energy content</u> | 32 |
| (a) Redshank prey | 32 |
| (b) Oystercatcher prey | 34 |
| <u>2.9</u> <u>Assimilation efficiency</u> | 34 |
| (a) Validity test that ash is not assimilated | 35 |
| <u>2 10</u> <u>Incomplete ingestion</u> | 36 |

| | <u>Page</u> |
|--|-------------|
| <u>2 11</u> <u>Handling times</u> | 37 |
| (a) Redshank | 37 |
| (b) Oystercatcher | 37 |
| (c) Reliability test of size estimates | 38 |
| <u>2 12</u> <u>Occurrence and duration of failed handling attempts</u> | 38 |
| (a) Redshank | 38 |
| (b) Oystercatcher | 39 |
| <u>2 13</u> <u>Energy cost of searching</u> | 40 |
| (a) Visually searching Redshank | 40 |
| (b) Tactile searching Redshank | 42 |
| (c) Oystercatcher | 42 |
| <u>2 14</u> <u>Energy cost of handling prey</u> | 42 |
| <u>2 15</u> <u>Radiotelemetric studies of metabolism</u> | 42 |
| (a) Study birds | 43 |
| (b) Study aviary | 43 |
| (c) Harness | 44 |
| (d) Electrode positioning | 44 |
| (e) Operation procedure | 45 |
| (f) Relationship between heart rate and metabolism | 46 |
| (g) Costing behaviours | 47 |
| <u>2 16</u> <u>Further metabolism studies</u> | 48 |
| (a) The effect of windspeed | 48 |
| (b) Reliability test of mask technique | 48 |

| | <u>Page</u> |
|---|-------------|
| <u>PART THREE - Model tests</u> | |
| <u>2 17 Redshank</u> | 49 |
| 2 17 1 Search strategy | 49 |
| (a) Walking speed | 49 |
| (i) Field estimates of stride length | |
| (b) Angularity of search paths | 50 |
| 2 17 2 Diet choice | 50 |
| (a) Direct observations | 50 |
| (i) Reliability tests of direct observations | |
| (ii) Correction for stretching in estimates of worm length | |
| (b) Collections of pellets | 52 |
| (c) Collections around search paths | 52 |
| 2.17.3 Spatial exploitation pattern | 53 |
| <u>2 18 Oystercatcher</u> | 53 |
| 2.18.1 Search strategy | 53 |
| (a) Walking speed | 53 |
| 2.18 2 Diet choice | 53 |
| (a) Reliability test of shell collections | 54 |
| (b) Relationship between muscle scar dimensions and adductor muscle mass | 55 |
| (c) Relationship between shell mass and thickness | 55 |
| 2.18 3 Spacial exploitation pattern | 55 |

| | <u>Page</u> |
|---|-------------|
| <u>Chapter Three - Results</u> | |
| <u>PART ONE - Model parameters</u> | 56 |
| <u>3 1 Prey density - Redshank prey</u> | 56 |
| 3 1.1 <u>Hydrobia ulvae</u> | 56 |
| (a) Culross | 56 |
| (b) Skinflats | 56 |
| (c) Variation in the size distribution | 57 |
| 3 1 2 <u>Macoma balthica</u> | 57 |
| (a) Culross | 57 |
| (b) Skinflats | 59 |
| 3.1.3 <u>Corophium volutator</u> | 59 |
| (a) Culross | 59 |
| (b) Skinflats | 59 |
| (c) Variation in the size distribution | 60 |
| 3.1 4 Polychaetes | 60 |
| (a) Culross - Nephys hombergii | 60 |
| (b) Skinflats - Nereis diversicolor | 61 |
| 3 1.5 Oligocheats | 61 |
| <u>3 2 Prey density - Oystercatcher prey</u> | 62 |
| 3.2.1 <u>Mytilus edulis</u> | 62 |
| <u>3.3 Prey energy content - Redshank prey</u> | 63 |
| 3.3.1 <u>Hydrobia vulvae</u> | 63 |
| 3.3.2 <u>Macoma balthica</u> | 64 |
| 3.3.3 <u>Corophium volutator</u> | 65 |
| 3.3 4 Oligocheats | 66 |
| 3 3 5 Polychaets | 66 |
| <u>3 4 Prey energy content - Oystercatcher prey</u> | 66 |

| | <u>Page</u> |
|--|-------------|
| 3 4.1 <u>Mytilus edulis</u> | 66 |
| (a) Flesh | 66 |
| (b) Shell | 68 |
| (c) Incomplete ingestion | 69 |
| <u>3 5 Biochemical composition and calorific content</u> | 69 |
| (a) Biochemical composition | 69 |
| (b) Energy content | 70 |
| <u>3 6 The relative importance of changes in prey characteristics on the gross energy availability to wading birds throughout the winter</u> | 70 |
| (a) Redshank prey | 71 |
| (b) Oystercatcher prey | 71 |
| <u>3 7 Assimilation efficiency</u> | 71 |
| (a) Test that ash is not assimilated | 72 |
| <u>3.8 Prey availability</u> | 72 |
| 3.8.1 Visual foraging redshank | 72 |
| (a) <u>Hydrobia ulvae</u> | 72 |
| (b) <u>Corophium volutator</u> | 73 |
| (c) <u>Macoma balthica</u> | 75 |
| (d) Polychaetes | 75 |
| 3 8 1.1 Surface cues - reliability of identification | 75 |
| 3 8 2 Tactile foraging Redshank | 76 |
| (a) <u>Hydrobia vivae</u> | 76 |
| (b) <u>Corophium volutator</u> | 76 |
| (c) <u>Macoma balthica</u> | 76 |
| 3 8.3 Oystercatcher | 77 |
| (a) <u>Mytilus edulis</u> | 77 |

| | <u>Page</u> |
|---|-------------|
| <u>3 9</u> <u>Feeding path width</u> | 77 |
| (a) Direct estimates | 77 |
| (b) Indirect estimates | 77 |
| <u>3 10</u> <u>Prey handling time - Redshank</u> | 79 |
| (a) visual searching | 79 |
| (b) tactile searching | 79 |
| <u>3 11</u> <u>Prey handling time - Oystercatcher</u> | 80 |
| <u>3 12</u> <u>Reliability tests of prey item identity</u> | 82 |
| (a) Redshank | 82 |
| (b) Correction of worm length for stretching | 83 |
| (c) Oystercatcher | 83 |
| <u>3 13</u> <u>False recognition, unsuccessful manipulation and</u> <u> kleptoparasitism</u> | 84 |
| (a) Redshank | 84 |
| (b) Oystercatcher | 85 |
| <u>3 14</u> <u>Indirect calorimetric studies of metabolism</u> | 86 |
| (a) Resting metabolism | 86 |
| (b) Active metabolism | 87 |
| <u>3 15</u> <u>Radiotelemetric studies of metabolism</u> | 88 |
| (a) The relationship between carbon dioxide production, oxygen consumption and heart rate over short (2.5s) durations in the laboratory. | 88 |
| <u>3.16</u> <u>Estimates of energy expenditure in the aviary</u> | 90 |
| (a) Variation in heart rate throughout short bouts of spontaneous activity | 90 |
| (b) Handling effects | 91 |

| | <u>Page</u> |
|--|-------------|
| (c) Predicted energy expenditure during various behaviours | 91 |
| (d) Comparison of energy expenditure whilst prey searching, prey handling and resting at temperatures below the lower critical temperature | 92 |
| <u>PART TWO - Model predictions and tests</u> | 94 |
| <u>3 17 Search strategy</u> | 94 |
| 3.17.1 Redshank - visual searching walking speed | 95 |
| 3.17.2 Redshank - visual versus tactile foraging | 97 |
| 3.17.3 Redshank - foraging versus non-foraging | 98 |
| 3.17.4 Oystercatcher - visual searching walking speed | 100 |
| 3 17.5 Redshank - angularity of search path | 101 |
| <u>3 18 Diet choice - Redshank</u> | 102 |
| 3.18.1 Predictions of the maximization of net energy gain models and alternate models | 102 |
| 3.18 2 Spatial and temporal variation in profitability | 104 |
| (a) <u>Hydrobia ulvae</u> | 104 |
| (b) <u>Corophium volutator</u> | 106 |
| (c) <u>Macoma balthica</u> | 107 |
| (d) Polychaets | 108 |
| 3 18 3 Comparison of profitabilities across prey types | 108 |
| 3.18.4 Comparison of observed and predicted diets | 109 |
| (a) Direct observation | 109 |
| (b) Collections around search paths | 112 |
| (c) Pellet collections | 112 |

| | <u>Page</u> |
|---|-------------|
| <u>3 19</u> <u>Diet Choice - Oystercatcher</u> | 115 |
| <u>3 20</u> <u>Spatio-temporal exploitation patterns</u> | 124 |
| | |
| <u>Chapter Four - Discussion</u> | 127 |
| <u>PART ONE - Model parameters</u> | 127 |
| <u>4 1</u> <u>Prey density - Redshank prey</u> | 127 |
| (a) <u>Hydrobia ulvae</u> | 127 |
| (b) <u>Corophium volutator</u> | 128 |
| (c) <u>Macoma balthica</u> | 128 |
| (d) Polycheates | 129 |
| <u>4 2</u> <u>Prey density - Oystercatcher prey</u> | 130 |
| (a) <u>Mytilus edulis</u> | 130 |
| <u>4 3</u> <u>Prey body mass</u> | 130 |
| (a) <u>Hydrobia ulvae</u> | 130 |
| (b) <u>Corophium volutator</u> | 131 |
| (c) <u>Macoma balthica</u> | 132 |
| (d) <u>Mytilus edulis</u> | 133 |
| <u>4 4</u> <u>Biochemical and caloric contents</u> | 134 |
| <u>4.5</u> <u>Assimilation efficiency</u> | 135 |
| <u>4 6</u> <u>The relative importance of changes in prey characteristics</u> <u>for gross energy availability to wading birds throughout the</u> <u>winter.</u> | 136 |
| <u>4 7</u> <u>Prey availability</u> | 139 |
| (a) Visual foraging Redshank | 139 |
| (b) Tactile foraging Redshank | 141 |
| (c) Oystercatcher | |

| | <u>Page</u> |
|--|-------------|
| <u>4 8</u> <u>Handling time</u> | 142 |
| (a) Redshank | 142 |
| (b) Oystercatcher | 143 |
| | |
| <u>4 9</u> <u>False recognitions, unsuccessful manipulation and kleptoparasitism</u> | 146 |
| (a) Redshank | 146 |
| (b) Oystercatcher | 147 |
| | |
| <u>4 10</u> <u>Metabolism - Redshank</u> | 147 |
| (a) The interrelationship of carbon dioxide production oxygen consumption and heart rate, over short periods in the laboratory. | 147 |
| (b) Individual differences | 151 |
| (c) Handling effects | 151 |
| (d) Variation in heart rate during short duration activities | 152 |
| (e) Resting metabolism | 152 |
| (f) Non-walking active metabolism | 154 |
| | |
| <u>4.11</u> <u>Metabolism - Oystercatcher</u> | 159 |
| | |
| <u>PART TWO - Model tests and general discussion</u> | 160 |
| | |
| <u>4 12</u> <u>Search strategy</u> | 160 |
| (a) The relationship between pacing rate, stride length and walking speed | 160 |
| (b) Comparison of predicted and observed search speeds | 160 |
| (c) Changes in foraging mode | 164 |
| (d) Foraging versus non-foraging | 166 |
| (e) Angularity of the search path | 168 |
| (f) Spatio-temporal exploitation patterns | 168 |

| | <u>Page</u> |
|--|-------------|
| <u>4 13</u> <u>Diet Choice</u> | 168 |
| (a) Profitability and the effects of including costs on diet choice predictions | 168 |
| (b) Temporal changes in profitability | 172 |
| (c) Comparison of observed and predicted diets | 173 |
| (i) Redshank | |
| (ii) 'Prizing' Oystercatchers | |
| (iii) 'Hammering' Oystercatchers | |
| (d) Daily energy budgets of Oystercatchers and the maximization of net energy gain | 194 |
| Summary | 201 |

ABSTRACT

A model is presented which predicts the simultaneous searching strategy (walking speed) and diet choice of a terrestrial predator, assuming the behaviour is selected to maximize the net rate of energy gain. The model predicts an inverse relationship between predator velocity and prey availability, independent of prey type, and that predators should stop foraging below a critical prey availability. It is predicted that diet choice should become more restricted with increases in the availability of highly profitable prey (i.e. net energy return per second spent handling) but broader with increases in the relative density of low profitability prey.

Parameters of the model, prey availability, energy content and handling time were measured for the common prey of two estuarine wading birds - the Redshank (Tringa totanus L.) and the Oystercatcher (Haematopus ostralegus L.) on the mid-estuarine Firth of Forth, Scotland. Predator energy expenditures whilst handling and searching for prey were estimated using radiotelemetry of the heart rate from six unrestrained Redshank in an outdoor aviary. At the lower critical temperature (16°C), the handling costs averaged 1.9xBMR (Aschoff and Pohl 1971) and 2.0xBMR for pecking and probing respectively, whilst searching cost 1.7xBMR (walking at 30 cm.s⁻¹).

Observed walking speeds in both species were well matched with the model's predictions at medium and high encounter rates, but at low encounter rates (2 items m walked⁻¹) were lower than predicted. The critical low availability at which it is profitable to stop foraging did not occur in the field during the study period (February 1981 - May 1982).

In Redshank the observed diet was not consistent with the net energy maximization model in Autumn or Early and Late winter and instead fitted better a model of gross protein maximization. In spring the observed diet was best described by the maximization of net energy gain. Including costs had a significant effect on the diet predictions in the Redshank.

Differences between predicted and observed diet choice in the Oystercatcher were a result of the underselection of very large, high profitability items and partial selection of low ranking prey. Including costs had no effect on the model's predictions for the Oystercatcher.

Differences between model predictions and the observed behaviour are discussed. In the 'prizing' Oystercatcher differences appeared to be a result of inaccuracy in collection of one of the model parameters (unsuccessful manipulation rates) and invalid assumptions concerning the discriminant abilities of the predator.

Whilst conflicting selective pressures - protein requirements and the avoidance of bill damage, probably explain the deviations in Redshank and 'hammering' Oystercatchers respectively.

Acknowledgements

I am pleased to acknowledge the help and constructive criticism, both throughout the course of the work and in the preparation of this thesis, of my supervisor Dr. David Bryant

I should like to thank Professor W.R.A Muntz for allowing me to use the facilities of the Department of Biological Science at Stirling.

In addition, the following members of the University of Stirling staff devoted both time and effort to help resolve some of my problems, Dr. P. Tytler, Dr. D. McLusky, Dr D Newberry, Dr P. Tatner, Mr A Annan and Mr A Micheals.

I am indebted to Dr I Duncan of the Poultry Research Station, Roslin, Midlothian, who taught me the operational procedures for implantation of the ECG transmitter

Many of my colleagues provided stimulating discussion and practical help, especially Gareth Jones Also, I should like to express my gratitude to Dr. N Clark of the University of Edinburgh, and Dr R. Furness, Mr. N Metcalfe and Mr H Galbraith of the University of Glasgow, who caught the experimental Redshank, and Mr. B. Bonning who supplied handreared Oystercatchers and Redshank. My thanks are also due to Mrs. P. Brown who typed the manuscript.

Finally, I should like to thank my wife Mary who has provided practical help, often in unpleasant weather conditions, and encouragement throughout the past three years

ERRATUM

For polychaeta read polychaeta

Chapter one(1 1) INTRODUCTION

Models which attempt to predict an animal's behaviour on the assumption that behaviour is selected to maximize fitness have recently generated much interest (Southwood 1977, Krebs et al. 1983). Many of these models have concerned reproductive behaviour - where the goal, maximization of lifetime reproductive output, is a direct measure of fitness (e g. Pianka and Parker 1975, Stearns 1976, Southwood 1977). In other fields such a direct measure of the fitness benefits of alternative behavioural strategies has not been possible, such as in the application of game theory to aggressive interactions, (Maynard Smith, 1983).

Despite this limitation, one field where considerable progress has been made is in understanding behavioural and ecological aspects of foraging.

Foraging is the method by which animals collect both the energy and nutrients necessary for reproduction and survival. A foraging animal must make several decisions concerning the manner in which it feeds - what prey should it eat?, when and where should it search for food?, and which searching method should it use? (Krebs 1978).

The consequences of these decisions reach beyond the individual predator and prey involved, because foraging behaviours have important effects on ecological processes at the population and community levels. At the population level it is ultimately an animal's ability to exploit food resources which limits the size of its population (Lack 1954, Newton 1980). Whilst some prey populations are regulated by the foraging behaviour of predators (Huffaker and Kennet 1956, Dodd 1959). At the community level, feeding specializations are one of the major methods by which animals avoid interspecific competition and hence maintain ecological isolation (Lack 1971, McArthur 1972). In addition, the patterns and rates of energy flow and nutrient cycling are highly

influenced by foraging behaviours (Odum 1971) and predation patterns can effect the diversity of lower trophic levels (Paine 1980, Clark 1962). Simple models capable of predicting foraging behaviours of individuals may give valuable insights into processes at these higher levels of organisation, which are inherently complex and difficult to study (Ricklefs 1972).

In the mid 1960's and early 1970's it was reasoned independently by several researchers that animals collecting food efficiently might have a selective advantage over those not foraging efficiently - because efficient foragers might.

- (a) spend less time in energy costly foraging behaviours or exposed to an increased risk of predation, whilst foraging for a given amount of energy or nutrients, or
- (b) have more of any limiting resource available for either their own survival or to allocate to reproduction (Emlen 1966, McArthur and Pianka 1966, Schoener 1971, Royama 1971).

All these early studies assumed that the limiting resource in predatory animals is energy. Krebs et al. (1983) suggest this was because this problem is more tractable, however, it is clear the early researchers did believe that maximization of net energy gain (as opposed to net nutrient gain) was commensurable with fitness (see Schoener 1971 particularly). This belief probably originated in observations that nutrient requirements of animals are very small when compared with energy requirements. For example, in the ectothermic brown trout (Salmo trutta L.) demand for energy (grams carbohydrate) - Keast and Welsh 1964, exceeds the nutrient demand (g) (Phillips 1964) by approximately 10^5 - 10^6 times.

Between the late 1960's and late 1970's a wealth of theoretical models was produced which attempted to predict foraging behaviour under

the premise of maximization of net energy gain (for reviews see Pyke et al. 1977, Krebs 1978, Morse 1982 and Krebs et al. 1983). Most of these models concerned the problem of what an animal should eat (Diet choice) or where it should forage (patch choice), but relatively scant attention was focussed on the problems of choice of prey searching method, or when an animal should allocate its hunting effort.

Tests of these models, under laboratory conditions, have been performed on a phylogenetically diverse range of animals, from arthropods (arachnada- Rypstra 1982) and molluscs (nudibranchia Hall et al. 1983) to birds and mammals (eg Krebs et al. 1974, Ebersole and Wilson, 1981). Generally these studies have involved manipulation of one or more of the parameters influencing foraging behaviour and compared observed responses with those predicted by various models e.g. Cowie 1977, Krebs et al. 1977, Elner and Hughes 1978, Gibson 1980, Pastorak 1980, Barnard and Brown 1981, Gardner 1981.

Whilst such laboratory studies allow a degree of control over independent variables which is not possible in field studies, they may be criticized on at least two fundamental grounds.

Firstly, laboratory animals are commonly under no selective pressure to maximize their energy intake or minimize foraging time because they are fed ad lib, and are kept in controlled environments where energy expenditures are reduced, because of a decreased thermoregulatory energy requirement (in homeotherms), and restrictions on activity. In addition, they are seldom allowed to breed and consequently are unable to devote surplus energy to reproduction.

Rozin and Meyer (1961) and Lawrence and Mason (1955) found that Goldfish (Carassius auratus) and rats (Rattus sp) respectively, kept on a 8 hours light and 16 hours dark regime ate enough food to maintain an energy balance, but were capable of increasing their rate of food intake when the light period was reduced to only one hour, to such an extent

that they were still able to maintain an energy balance. The animals probably fed at a rate below their capacity initially because they were under no pressure to maximize energy intake.

Attempts to introduce pressure by reducing the available food and or foraging time such that animals are kept below their normal body mass may precede a given hypothesis concerning the optimized quantity. Under conditions of starvation it is not surprising that animals behave in a manner which maximizes the net energy gain, but these type of data may provide little information concerning the foraging behaviour of the wild animal, if starvation is a relatively unimportant or infrequent cause of mortality in the field. In a similar manner rats (Rattus sp) deprived of nutrients choose food rich in nutrients they are lacking (Richter and Rice 1945), yet few would claim such behaviours reflect diet choice in the wild.

Unfortunately, most of the laboratory tests of foraging models, confirming the maximization of net energy gain, have been performed on starved animals (eg Krebs et al 1974, Werner and Hall 1974, Cowie 1977, Elner and Hughes 1978) whilst other tests, on unstarved animals, have found no evidence to support the hypothesis (Emlen and Emlen 1971).

Secondly, the process by which animals have acquired the ability to behave optimally is presumed to be natural selection (Morse 1982, Krebs et al. 1983). Natural selection will, however, only maximize net energy gain, or gain of some other currency, for the conditions that the behaviour was selected. Deviations from optimal performance in the laboratory may then reflect the similarity or difference between the problems the animal is required to solve in the field and in the laboratory. Krebs et al. (1974) for example moved meal worms (Tenebrio sp.) on a conveyor belt past Great Tits (Parus major) in an attempt to simulate insects moving across the search path. Observed and predicted diets on the premise of energy maximization were well matched, presumably

because the laboratory situation did bear sufficient resemblance to the experience of birds in the wild (although the birds were starved prior to the experiments - see above).

In contrast, Beukema (1966) attempted to assess optimization in the search paths of foraging sticklebacks (Gasterosteus aculeatus) by placing them in the hexagonal maze and recording the cells through which the fish swam. The behaviour never approached the optimum solution, perhaps because the problem was too remote from the natural situation. Also Dunstone and O'Conner (1979) studied the foraging abilities of mink (Mustella vison) when visiting underwater hides, some of which contained dead fish. The observed behaviour was sub-optimal because the mink revisited hides from which they had already removed fish. Dunstone has suggested revisiting hides where the mink has previously been successful may be optimal 'in the field' because live fish are likely to restock such hides whilst in the laboratory this could not occur.

Krebs et al. (1983) suggest criticisms of laboratory tests of foraging models are criticisms of the whole reductionist approach to scientific investigation and not criticisms of the tests themselves. The foraging models were developed, however, to enquire of the validity of a certain hypothesis concerning the manner in which foraging behaviours are selected. Laboratory studies, where animals are unlikely to have conflicting selective pressures (e.g. predator avoidance and excessive nutrient demands, such as may occur in reproduction) coupled with an excess of food, are unlikely to generate important ecological data - whether they find support for a hypothesis or refute it.

Field tests of the foraging models have found both support for the premise of net energy maximization (e.g. Davies 1977a, Goss Custard 1977a, De Benedictis 1978, Zach 1979, Barnard and Stephens 1981, Hodges 1981, Best and Bierzychudck 1982) and disagreement between observed and predicted behaviours (Goss Custard 1977b, Vadas 1977, Belovsky 1978,

Heinrich 1979, Sih 1979, Milton 1980, Rapport 1980, Davies and Houston 1981, Mittelbach 1981, Lobel and Ogden 1981). In general, agreement has been less common in the field than in the laboratory. In most studies deviations of observed behaviour, from the predicted behaviours which would maximize net energy returns, appear to be a result of conflicting selective pressures. Animals could obtain greater net energy gains by foraging in the predicted manner, but only by paying a non-energetic penalty, such as an increased risk of mortality, which would reduce fitness.

Whilst arguing that field studies probably provide ecologically more important data, laboratory and field studies share some common problems.

Firstly, because foraging models have developed in relative isolation, for example generating predictions of diet choice or patch choice but not both simultaneously (but see Heller (1980)), tests of these models have also tended to occur in isolation, whilst the animals' behaviour is selected on the basis of a global solution to all problems simultaneously. One major problem occurs in models which aim to predict diet choice. Probably the major factor influencing diet choice is prey encounter rate (Estabrook and Dunham 1976). Prey encounter rate depends on the predator searching strategy, e.g. an animal walking faster encounters prey more frequently. Models predicting search strategy (Evans 1976, Norberg 1977, Krebs 1978) all suggest prey density is an important factor influencing the searching behaviour. Hence, predictions of diet changes in relation to density from diet models which assume a fixed search strategy are likely to be erroneous.

Goss Custard (1977c) has suggested that sub-optimal foraging in the Redshank (Tringa totanus) may reflect as much a failure to adopt an appropriate search speed as failure to choose the predicted diet.

A second problem is that whilst maximization of NET energy gain implicitly assumes that animals are sensitive to energy expenditure as

well as energy gain, very few tests of the models include any attempt to measure energy costs. Quantitative support for NET energy gain models by GROSS energy gain tests suggest either the effects of costs on model predictions are undetectable or that animals are unable to respond to these costs. If this latter hypothesis proves correct, current tests which provide support for the maximization of net energy gain hypothesis may in fact provide evidence which refute it.

A further problem is that of eliminating alternative hypotheses. Sutherland (1982) and Werner and Hall (1974) have both shown different predators select prey which are the most profitable, in the field and laboratory respectively. In both these studies the most profitable prey were also the largest and probably therefore more conspicuous. A predator selecting prey at random, using visual cues alone, might therefore have selected the same prey (Krebs 1978) and these tests do not provide a rigorous test of the model predictions (see also Barnard and Brown 1981).

In the light of these problems the aims of this study were.

- (a) to develop a foraging model which predicts simultaneously the search strategy and diet choice of a terrestrial predator assuming the behaviour is selected to maximize the net rate of energy gain.
- (b) To collect the necessary parameters of the model and to formulate and test the model predictions against alternative hypotheses of random selection and/or nutrient selection by a terrestrial predator in the field.

(1.2) The foraging model.

A model is presented predicting searching behaviour and diet choice of a terrestrial predator, assuming the behaviour is selected to maximize the net rate of energy gain. The approach is to consider first the search strategy when searching for a randomly distributed item of a

single type. Having defined the factors influencing the choice of search strategy, the model is then expanded to include several prey types to predict the optimal combination of search strategy and diet choice. Some effects of relaxing the random distribution constraint are discussed.

(a) Rationale

It is generally accepted that predators are divisible into two types, those which 'sit and wait' for prey, and consequently do not incur any additional energy expenditure for searching, compared to resting, and mobile hunters which do incur a searching cost (Pianka 1966, Schoener 1971). Within each category there is a subset of alternative strategies which are characterized by the values placed on a small number of continuous variables, the time spent waiting when unsuccessful and direction and distance of movement in the 'sit and wait' strategy and search speed and path angularity in the 'constant motion' strategy. This model considers the factors influencing the choice of values placed upon continuous variables within the 'constant motion' method for a terrestrial predator feeding on sedentary prey.

(b) Search Speed

Consider a terrestrial predator which encounters prey both singly and at random. For each prey we may define a value P_i - the profitability of the i th item, which equals the net energy gain when handling or attempting to handle an item of that type. Schoener (1971) defined profitability as

$$P_i = p_{ci} \frac{E_i - \epsilon_{hi} T_{hi}}{T_{hi}} \quad (1)$$

where p_{ci} = the probability of capturing item (i) once attacked
 E_i = the assimilable energy content of item (i)
 T_{hi} = the handling time for item (i)
 ϵ_{hi} = the rate of energy expenditure whilst handling item (i)

Subsequent models have either been the same as Schoener's or involved deletion of the p_{ci} and/or the $\epsilon_{hi} \cdot T_{hi}$ terms (e.g. Charnov 1976).

These models do not accurately reflect the time and energy investment in unsuccessful handling attempts. Deleting the p_{ci} and $\epsilon_{hi} T_{hi}$ results in overestimation of profitability because the time and/or energy investment in unsuccessful handling is ignored, while multiplying the net energy gain rate by the success rate of attacks (equation (1)) underestimates the profitability because unsuccessful attacks are probably of shorter duration than successful attacks (e.g. Pastorak 1980).

The process of handling an item is divisible into four stages:

- (a) Recognition - from initial sensory contact to initiation of attack.
- (b) Pursuit - from initiation of attack to first physical contact (=0 when prey sedentary).
- (c) Manipulation - from first physical contact to start of ingestion.
- (d) Ingestion.

Handling attempts may be terminated during any stage. For each stage we may define four variables which differ between prey types. The rate of energy expenditure during that stage, the duration of the stage during successful and unsuccessful handling attempts and the rate at which unsuccessful handling attempts terminate in that stage. In addition, two further variables, the energy intake for successful and unsuccessful attempts, may be defined for the ingestion stage (Table 1).

For a sedentary prey of type (i) the total time investment for a single item = T_{ti}

Table 1

Symbols used to represent handling parameters of an item (1)

| STAGE | DURATION | ENERGY EXPENDITURE | RATE OF UNSUCCESSFUL ATTEMPTS * | DURATION OF UNSUCCESSFUL ATTEMPTS | ENERGY GAIN | ENERGY GAIN IN UNSUCCESSFUL ATTEMPTS |
|--------------|----------|--------------------|---------------------------------|-----------------------------------|-------------|--------------------------------------|
| RECOGNITION | T_{r1} | ϵ_{r1} | r_{UR1} | UT_{r1} | - | - |
| PURSUIT | T_{p1} | ϵ_{p1} | r_{UP1} | UT_{p1} | - | - |
| MANIPULATION | T_{m1} | ϵ_{m1} | r_{UM1} | UT_{m1} | - | - |
| INGESTION | T_{i1} | ϵ_{i1} | r_{UI1} | UT_{i1} | E_1 | UE_{i1} |

* Rate of unsuccessful attempts equals rate relative to successful attempts

$$T_{ti} = TR_i + TM_i + TI_i \quad (2)$$

where $TR_i = (T_{r1})(rUM_1 + rUE_1 + 1) + rUR_1, UT_{r1}$
 $TM_i = (T_{m1})(rUI_1 + 1) + rUM_1 UT_{m1}$
 $TI_i = (T_{i1} + rUI_1 UT_{i1})$ - see Table 1.

the total energy expenditure during this time = ϵ_{ti} .

$$\epsilon_{ti} = TR_i \cdot \epsilon_{ri} + TM_i \cdot \epsilon_{mi} + TI_i \cdot \epsilon_{ii} \quad (3)$$

and the total energy gain = E_{ti}

$$E_{ti} = E_i + rUI_i UE_{ii} \quad (4)$$

Profitability (P_i) may therefore be redefined

$$P_i = \frac{(E_{ti} - \epsilon_{ti})}{T_{ti}} \quad (5)$$

In a terrestrial predator foraging on an item i of profitability (P_i),

the net energy gain = E_{neti} , where

$$E_{neti} = \frac{(E_{ti} - \epsilon_{ti}) - T_s \epsilon_s}{T_{ti} + T_s} \quad (6)$$

where T_s = the time spent searching

and ϵ_s = the energy expenditure whilst searching

Across a wide range of terrestrial predators the energy cost of searching (ϵ_s) is equivalent to that of locomotion, and is a linear

function of velocity (Schmidt Nielsen 1972, Taylor and Rowntree 1973, Fedak et al 1974) which is described by the following equation

$$\epsilon_s = \epsilon_{re} b + a v_1 \quad (7)$$

where ϵ_{re} = the energy expenditure whilst resting

v_1 = predator velocity

b = the fixed cost of locomotion

a = the incremental cost of locomotion

The time spent searching (T_s) equals the reciprocal of the encounter rate with successfully ingested items (e_{s1}) which for a sedentary prey item (1) is described by the equation

$$e_{s1} = D_1 P_{a1} P_{d1} P_{c1} x v_1 \quad (8)$$

where D_1 = the density of the item (1)

P_{a1} = the proportion of time an individual item (1) is available

x = the maximum distance the predator can reach to either side of the search path = the 'foraging path width'

P_{d1} = the probability of an item within x being detected

$$\text{Hence, } T_s = 1/(D_1 P_{a1} P_{d1} P_{c1} x v_1) \quad (9)$$

Substituting (9) and (7) into (6)

$$E_{net1} = \frac{(E_{t1} - \epsilon_{t1}) - [1/(D_1 P_{a1} P_{d1} P_{c1} x v_1)] [\epsilon_{re} b + a v_1]}{T_{t1} + 1/(D_1 P_{a1} P_{d1} P_{c1} x v_1)}$$

which simplifies to

$$E_{neti} = \frac{(E_{ti} - \epsilon_{ti}) D_i \cdot p_{ai} \cdot p_{di} p_{ci} v - (\epsilon_{re} b)/v_1 - a}{T_{ti} \cdot D_i p_{ai} p_{di} p_{ci} x + 1/v_1} \quad (10)$$

For a predator of given body mass, ϵ_{re} , b , a and x are constant. For a prey of given type, E_{ti} , ϵ_{ti} and T_{ti} are constant, to a given predator. The effect on E_{neti} of varying predator search speed (v) and prey availability ($= D_i \cdot p_{ai} \cdot p_{di}$) for predators of varying body mass was investigated by setting appropriate values for the constants as follows

$E_{ti} = 10^{-3}$ x the predator body mass (wet), assuming a calorific equivalent of $16.5 \text{kJ} \cdot \text{g}^{-1}$ (Crisp 1971) and an assimilation efficiency of 75%

$T_{ti} = 25 \text{s}$

$\epsilon_{ti} =$ assumed to equal $1.5 \times \epsilon_{re}$

$x =$ equal to the predator's height, where $h = aBM^b$, $a = 2$,
 $b = 0.33$ and $BM =$ body mass.

$\epsilon_{re} = 1.3 \times$ Basal metabolic rate (BMR) (King 1974), basal metabolism in the α phase (Kleiber 1967 for basal).

$b = 1.2$ (Fedak et al 1974).

$a =$ (after Fedak and Seeherman 1979).

$p_{ci} = 1$

Predator search speed (v_i) was allowed to vary between 0 and

v_{max} - the maximum search speed. Although most terrestrial predators are capable of attaining speeds between 10 and $15 \text{m} \cdot \text{s}^{-1}$ for short periods (Schmidt Nielsen 1975), a searching predator must maintain its speed for long periods. Clark and McNeil Alexander (1975) define the maximum walking speed as $\sqrt{hc/g}$, where hc is the height of the predator's centre of gravity and g is acceleration due to gravity. It is assumed that $hc = 0.5h$ and that animals by running can sustain

approximately twice the maximum walking speed P_{d1} was assumed equal to 1.0. Availability ($=D_1 P_{a1} P_{d1}$) was allowed to vary between 0.001 and 500 items m^{-2} .

The effect of changes in predator velocity (v_1) and prey availability on E_{net1} for a terrestrial predator of body mass 0.1 kg are shown in Fig. 1. The effects for different body mass predators (0.1, 1, 10 and 100 Kg) were similar. At high prey availabilities increasing v_1 results in an increase in E_{net1} across all search speeds. Maximum E_{net1} occurs when $v_1 = v_{max}$. At some critical prey availability changes in speed result in no change in E_{net1} and at lower densities increases in v_1 lead to decreases in E_{net1} , and maximum E_{net1} occurs when $v_1 = 0$.

By definition the critical density where changes in E_{net1} are independent of v_1 occurs when

$$\frac{dE_{net1}}{dv_1} = 0 \quad (11)$$

given eqn (9) and abbreviating $D_1 P_{a1} P_{d1}$ to D_{a1} (= availability of the item (1))

$$\frac{dE_{net1}}{dv_1} = \frac{A - B}{(T_{t1} D_{a1} P_{c1} x v_1 + 1)^2} \quad (12)$$

$$\text{where } A = ((E_{t1} - \epsilon_{t1}) D_{a1} P_{c1} x - a) (T_{t1} D_{a1} P_{c1} x v_1 + 1)$$

$$B = T_{t1} D_{a1} P_{c1} x ((E_{t1} - \epsilon_{t1}) D_{a1} P_{c1} x v_1 - \epsilon_{re} b - a v_1)$$

Solving equation (12) for a critical value $D_{a1} \text{ crit}$, where equation (11) is satisfied

$$D_{a1} \text{ crit} = \frac{a}{[(E_{t1} - \epsilon_{t1}) + T_{t1} \epsilon_{re} b] x P_{c1}} \quad (13)$$

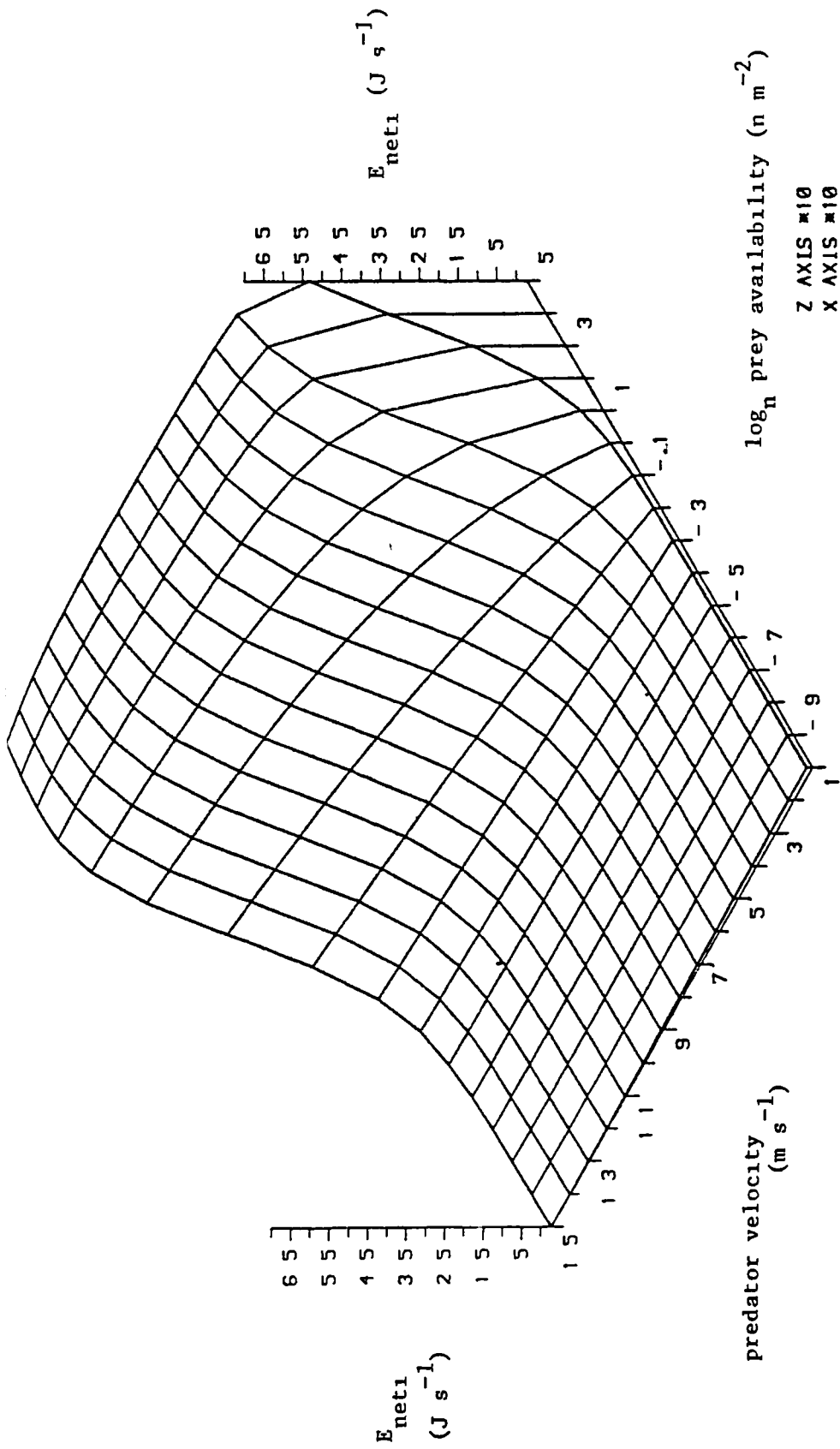

Fig. 1 The net energy gain whilst foraging (E_{net1}), for an item of type (1) ($J s^{-1}$) against predator velocity ($m s^{-1}$) and prey availability ($\log_n n m^{-2}$), for a predator of body mass 0.1 kg

This model predicts

- a) a terrestrial predator foraging on a sedentary prey item of type (i) should maximize the velocity at which it searches when the availability of that prey exceeds D_{ai} crit (equation 13).
- b) when the availability of the prey falls below D_{ai} crit the animal should stop foraging.

Previous treatments of search strategy in which a predator has a choice between only two alternatives (high and low speed) reach similar predictions. The predator should use the high speed method (= high cost) above a critical density and the low speed below it (Evans 1976, Norberg 1977, Krebs 1978). The suggestion that predators should therefore gradually increase their velocity as prey density increases (Norberg 1977, Krebs 1978) appears to be based on a misinterpretation of these earlier models.

Many factors may influence the speed attained by a predator which is attempting to maximize its velocity. One factor which will affect all predators is the rate at which it encounters prey items.

Consider a predator which sets out from an item (n) which it has just handled. Its initial velocity $u = 0$, it accelerates over a time T_{ac} until it reaches the maximum velocity v_{max} . The acceleration $a_p = v_{max}/T_{ac}$. If the predator reaches the next prey item (n+1) before T_{ac} , the speed it attains v_a , will be less than v_{max} .

Given

$$v_a = u + a_p \cdot T_{ac}$$

and d the distance travelled

$$d = u \cdot T_{ac} + 1/2 \cdot a_p \cdot T_{ac}^2$$

$$d = u \cdot \left[\frac{v_a - u}{a_p} \right] + 0.5 a_p \left[\frac{v_a - u}{a_p} \right]^2 \quad (14)$$

as $u = 0$

$$d = \frac{v_a^2}{2a_p} \quad (15)$$

$$\text{and } v_a = (2a_p d)^{0.5} \quad (16)$$

The distance between two items, including items which elicit handling attempts but ultimately provide no energy return, = d_i :

$$d_i = \frac{1}{(D_i \cdot P_{ai} \cdot P_{di} \cdot x)} \quad (17)$$

Combining equations (16) and (17).

$$v_a = \left[\frac{2a_p}{D_i \cdot P_{ai} \cdot P_{di} \cdot x} \right]^{0.5} \quad (18)$$

Solving equation (18) for a critical prey availability where

$$v_a = v_{\max}, \text{ called } D_{ai\text{CRIT}(1)}$$

$$D_{ai\text{CRIT}(1)} = \frac{2a_p}{(v_{\max})^2 \cdot x} \quad (19)$$

At $D_{ai\text{CRIT}(1)}$, the mean velocity (v_{me}) over the period of acceleration from 0 to $v_{\max} = 0.5 v_a$. Above $D_{ai\text{CRIT}(1)}$ the

attained speed (v_a) is described by equation (18) and $v_{me} =$

$0.5 \cdot v_a$ At availabilities below $D_{ai_CRIT(1)}$ the time spent at v_{max} increases, v_{me} therefore approaches v_{max} as availability approaches zero.

Below $D_{ai_CRIT(1)}$.

$$v_{me} = \frac{1/D_i \cdot P_{ai} P_{di} \cdot x}{T_{ac} + \frac{1}{(d_i \cdot P_{ai} P_{di} \cdot x) v_{max}} - \frac{v_{max}}{2 a_p}} \quad (20)$$

which simplifies to

$$v_{me} = \frac{1}{\frac{1}{v_{max}} + D_i \cdot P_{ai} P_{di} \cdot x \cdot \left[\frac{T_{ac} - v_{max}}{2 a_p} \right]} \quad (21)$$

At a critical high prey availability (called $D_{ai_CRIT(2)}$) the predator encounters more than one prey within its reach. Above this availability the predator will ingest all the prey within its reach and then accelerate towards the edge of the cleared area. $D_{ai_CRIT(2)}$ is defined by the maximum distance the animal can reach forwards = $0.5x$, hence when:

$$D_{ai_CRIT(2)} = 1/0.5x^2 \quad (22)$$

the predator reaches its minimum search speed. At this availability, combining equations 22 and 18

$$v_a = (x \cdot a_p)^{0.5} \quad (23)$$

$$\text{and } v_{me} = 0.5(x \cdot a_p)^{0.5} \quad (24)$$

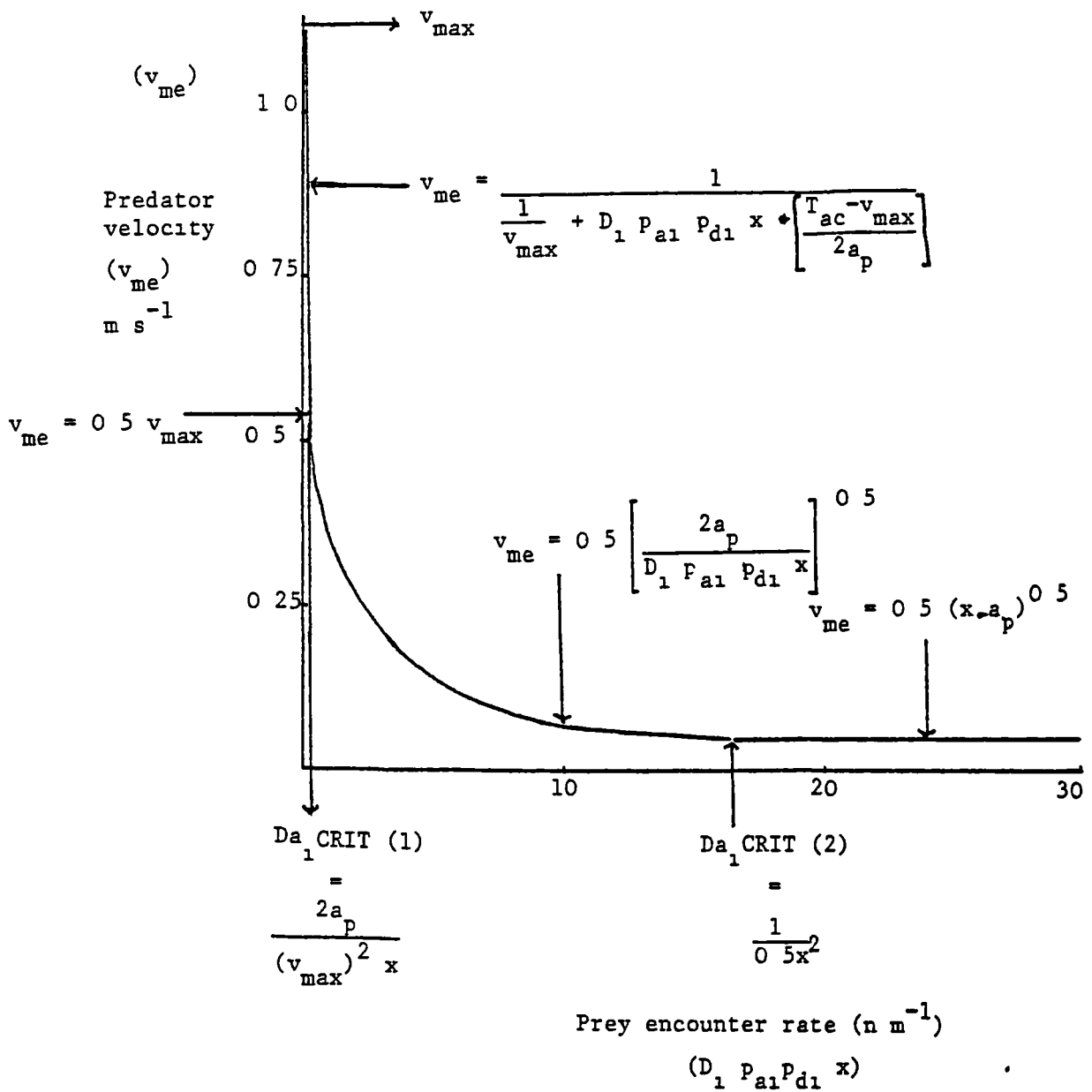

Fig 2 Theoretical relationship between predator velocity (v_{me}) and prey encounter rate, for a predator of body mass 0.1 kg, encountering prey of type 1 (For details of symbols see text), when velocity is acceleration limited

The relationship between mean walking speed (v_{me}) and prey encounter rate ($D_i p_{ai} \cdot p_{di} \cdot x$) for a predator of body mass 100g, assuming $T_{ac} = 5$ 0s is shown in Fig 2. A predator attempting to maximize its velocity will have a non-linear, inverse relationship between walking speed and prey encounter rate.

(c) Search path angularity

A turning animal increases the probability of crossing its own search path. As prey density where the animal has been feeding is depleted and E_{neti} increases with increases in density (equation 10 - Fig 2) any increase in the probability of crossing its own search path is disadvantageous. In an infinite random environment an animal should search in a straight line (see section 1.2 5).

(d) Diet choice and search strategy

If the predator expands its diet to include a second item, with a profitability of p_j , where $P_i > p_j$, the net energy gain = E_{netij} :

$$E_{netij} = \frac{(E_{ti} - \epsilon_{ti}) \cdot D_{ai} \cdot x + (E_{tj} - \epsilon_{tj}) \cdot D_{aj} \cdot x - \frac{\epsilon_{re} \cdot b}{v_{ij}} - a}{T_{ti} \cdot D_{ai} \cdot x + T_{ti} \cdot D_{aj} + (1/v_{ij})} \quad (25)$$

where v_{ij} equals the walking speed of the predator when it encounters items of both types i and j.

The effects of including the item are four-fold.

- (a) The gain over a standard distance is increased because the predator ingests both sets of items where previously it ingested only one.
- (b) The handling time is increased for the same reason.
- (c) Because the predator has an increased encounter rate with prey, its velocity will decrease and the time to cover a standard distance will be longer.
- (d) Although the animal walks slower and hence the cost of searching per

unit time decreases (equation 6) the time spent covering a standard distance increases ((c) above). The cost of covering a standard distance also increases as velocity decreases (Fedak et al. 1974) because there is a high fixed cost of locomotion ($=\epsilon_{re} b$)

The predator should include the item j when the increased time spent covering the standard distance (= b and c above) results in a greater net gain than would be obtained if the predator foraged for this extra time but excluded the item This occurs when:

$$\frac{(E_{tj} - \epsilon_{tj}) \cdot D_{aj} \cdot x - \epsilon_{re} \cdot b \left[\frac{1}{v_{ij}} - \frac{1}{v_i} \right]}{T_{tj} \cdot D_{aj} \cdot x + 1/v_{ij} - 1/v_i} > E_{neti} \quad (26)$$

The form of relationship between predator velocity (v) and encounter rate ($D \cdot p_a \cdot p_d \cdot x$) varies with the encounter rate. Below the critical availability $Da_i CRIT(1)$, the relationship is described by equation (21). Substituting (10) and (21) into (26) and rearranging the terms so that the left hand side equals the profitability of the item j

$$\frac{E_{tj} - \epsilon_{tj}}{T_{tj}} > \frac{(E_{ti} - \epsilon_{ti}) - \frac{\epsilon_{re} \cdot b}{v_i} - a + \frac{\epsilon_{re} \cdot b}{T_k}}{T_{ti} \cdot D_{ai} \cdot x + (1/v_i) - T_k} \quad (27)$$

where $T_k = T_{ac} - \frac{v_{max}}{2 \cdot a_p}$

When $D_i \cdot p_{ai} \cdot p_{di} \cdot x < Da_i CRIT(1)$ but $> Da_i CRIT(2)$ the relationship between encounter rate and velocity is described by equation (18). Substituting (10) and (18) into (26)

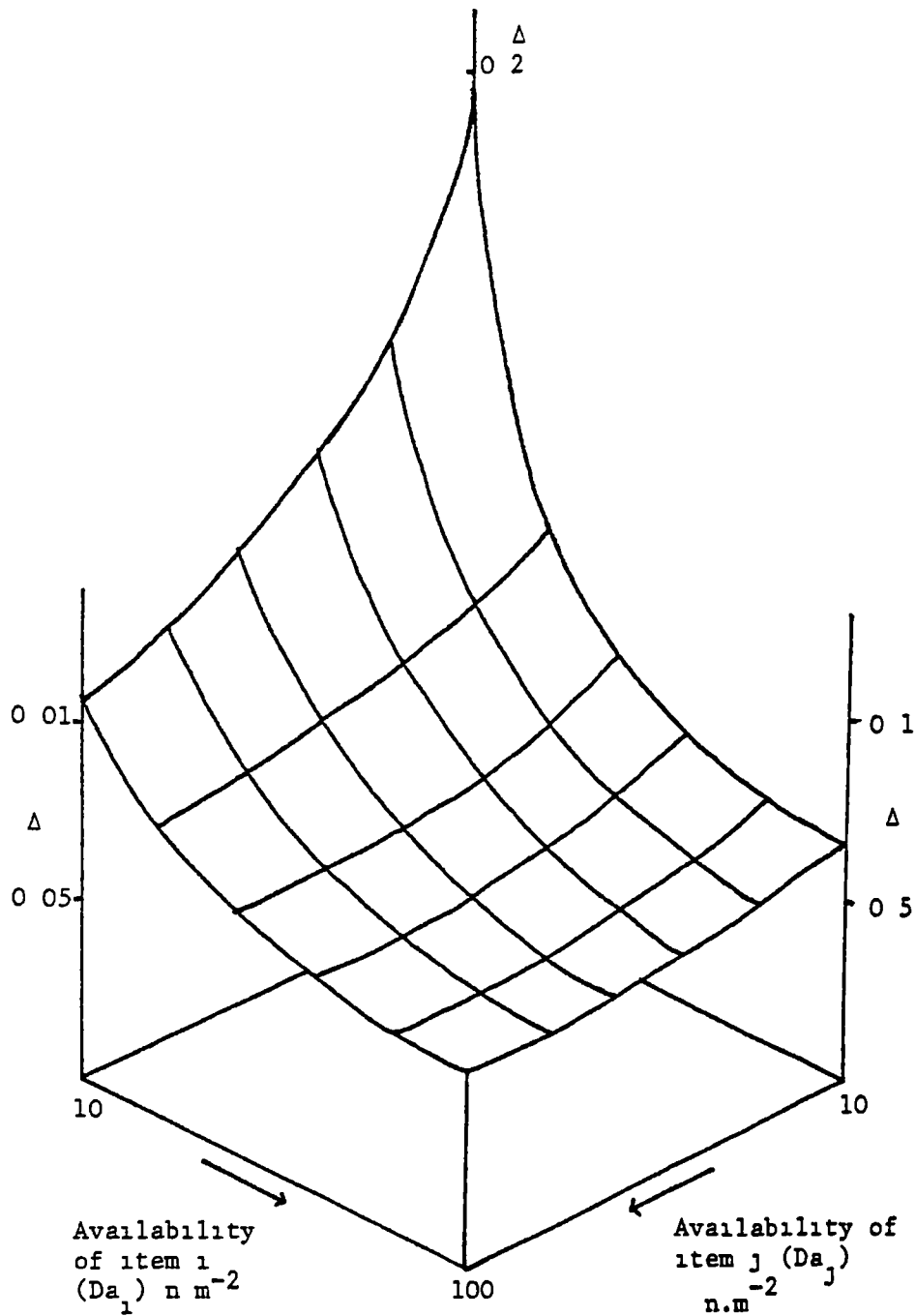

Fig 3 Changes in Δ (a term within the diet equation 28) with changes in the availability ($n \cdot m^{-2}$) of item (1) and item (j) (Da_1 and Da_j). Increases in Δ lead to a narrowing of the diet. For Da_j (the availability of the item of lower profitability), which appears in equation 28 only within the term Δ , this means increases in Da_j tend to increase the probability of the item j entering the diet. Increases in Da_1 have a much smaller effect on Δ , and hence, the probability of inclusion in the diet, when Da_1 is large. The effect of changes in Da_1 on the diet are more complex since Da_1 also occurs in equation 28 outside the term Δ .

then

$$\frac{E_{ti} - \epsilon_{ti}}{T_{tj}} = \frac{(E_{ti} - \epsilon_{ti}) D_{ai} x - \frac{\epsilon_{re} \cdot b}{v_i} - a + \epsilon_{re} b \Delta}{T_{ti} D_{ai} \cdot x + (1/v_i) - \Delta} \quad (28)$$

$$\text{where } \Delta = \frac{1}{D_{aj} \cdot x} \left[\frac{D_{ai} \cdot x + D_{aj} \cdot x}{2a_p} \right]^{0.5} - \frac{1}{D_{aj} \cdot x} \left[\frac{D_{ai} \cdot x}{2a_p} \right]^{0.5}$$

$$\text{and } D_{aj} = D_j \cdot p_{aj} \cdot p_{dj}$$

$$D_{ai} = D_i \cdot p_{ai} \cdot p_{di}$$

The inequalities (27) and (28) have a common property. Since Δ and $T_{ac} - (v_{\max}/2a_p)$ are always positive the right hand side of both inequalities exceed E_{neti} under all conditions. The profitability of the prey item P_j (equation (5)) must therefore be considerably greater than E_{neti} before inclusion of the item has the effect of increasing E_{net} . Under some circumstances, P_j may exceed E_{neti} but still not satisfy the inequality (either 27 or 28) and should therefore remain excluded from the diet.

Inequality (28) has a further property. Since the value Δ is dependent on encounter rate with item j , density of item j influences its own probability of inclusion in the diet.

The effect of changing both D_{ai} and D_{aj} on Δ was investigated by setting appropriate values to the constants x and a_p (as in previous simulation) and varying D_{ai} and D_{aj} between 0.1 and 100 items.m⁻². The effects of varying both D_{ai} and D_{aj} on Δ are shown in Fig 3. Increases in D_{aj} lead to decreases in Δ . Since decreases in Δ reduce the value of the right hand side of inequality (28) increases in D_{aj} will increase the probability of the items inclusion in the diet. This occurs because of the decelerating inverse

relationship between velocity and availability (Fig 2). Including the first few items of type (j) has a much greater effect on velocity than the last few. When including only a few items it is more probable that the deleterious effects on velocity will exceed the benefits, than when including a large number of items.

The effects of D_{aj} on Δ decrease as D_{a1} increases. It is therefore the relative density of item j which influences its inclusion into the diet. This occurs because the magnitude of the effects on velocity of including the first items depends on the position on the velocity availability curve (Fig. 2) which in turn depends on D_{a1} .

Above $D_{a1} \text{CRIT}(2)$ (-equation 22) where velocity and encounter rate are independent the availability of the item (j) exerts no influence on its entry into the diet.

The prediction of the diet choice part of the model are summarised as follows

- (a) Below a critical availability of included prey items (defined as $D_{a1} \text{CRIT}(2)$ - equation 22), an item will only be included in the diet when the profitability of that item (equation 5) greatly exceeds the net gain when including all items of greater profitability. In circumstances where profitability of the excluded item only just exceeds the net energy gain when excluding the item, the predator may maximize its rate of net energy gain by not incorporating the item into the diet.

This occurs because including the item affects not only the time and energy spent handling prey, over a given distance, but also decreases velocity, and therefore increases the time and energy spent searching that distance. As the effect of availability on velocity is greatest at low encounter rates (Fig. 2), the amount by which profitability must exceed the net gain excluding the item, before the item is included, decreases as availability of included

items increases. Above the critical availability (equation 22), where prey availability has no effect on predator velocity, the item should always be included when its profitability exceeds the net gain excluding the item.

- (b) As the relative density of an excluded item increases, the probability of it entering the diet also increases.
- (c) As net energy gain increases with prey density, (equation 10, Fig. 1), an item should either be included entirely, or rejected totally, from the diet. Including only a proportion of the prey is equivalent to including an item of equal profitability but lower density.

The predictions (a) and (b) of this model contrast with the predictions of the classic diet choice models (McArthur and Pianka 1966, Emlen 1966, Tullock 1970, Schoener 1971, Rapport 1971, Martin 1973, Timmin 1973, Pulliam 1974, Werner and Hall 1974, Charnov 1976, Elner and Hughes 1978) which state.

(i) An item should always be included when its profitability exceeds the net energy gain, when all items of greater profitability are included but it is excluded.

(ii) The density of an excluded item cannot influence its entry into the diet.

These differences are entirely because the above model includes effects of a non-linear inverse relationship between prey density and predator velocity, whilst the classic models (loc.cit) assume predator velocity is constant. Above a critical availability (defined in equation 22) where predator velocity is predicted to be independent of prey availability the predictions of the model are the same. Prediction (c) is common to this and the classic models.

- (e) Relaxation of random encounter constraint.

Non-random prey distributions include aggregations of prey where

prey density is markedly above that of the surrounding habitat. Because E_{net} increases with increases in prey density (equation 9, Fig. 1) the predator may improve its E_{net} in the long term by concentrating foraging effort in such areas, which for the purpose of this study may be called patches (McArthur and Pianka 1966).

There are several methods by which the predator may respond to prey densities in order to spend more time in patches of prey (Fraenkel and Gunn 1940). The inverse relationship between walking speed and prey density (Fig. 2) will necessarily result in more time being spent in the good patches (= orthokinesis). The predator may also vary the search path angularity. There are two potential methods by which changes in path angularity may result in an increased time spent in high density areas. The predator may increase path angularity in high density areas (= klinokinesis) (e.g. Smith 1974, Hassell and May 1974) or it may compare densities spatially along the search path and respond to changes in the density. Such a predator should move directly when prey density is increasing but increase angularity as prey density decreases (klino-taxis).

An important problem with models attempting to predict such responses is defining the distance, or time, over which the animal integrates information to estimate density or change in density (Cowie 1977, Ollason 1980). Consider a predator which forages in patches which have a mean width W_m . The problem facing the predator is to define the distance d_e over which estimates of density are made. As d_e gets short it eventually becomes less than d_1 , the inter-item distance (equation 17). In these conditions the variability in estimated density becomes very large. As d_e increases the variability in any one estimate decreases and the reliability of the estimate increases. As d_e increases above W_m the significance of density within the current patch on the current density estimate decreases, and consequently the

ability of the animal to respond to the 'patchiness' of the environment also declines.

To obtain the maximum reliability in density estimates, combined with maximum responsivity to environmental patchiness, the predator should set $d_e = W_m$ and respond to the estimated density as detailed above (orthokinesis, klinokinesis or klinotaxis).

Chapter twoMATERIALS AND METHODSPART ONE - Selection of study species, study sites and study periods(2.1) Selection of Study species

Estuarine wading birds (Haematopodidae and Charadriidae) were selected, firstly because they inhabit an open environment which facilitates observation and secondly because they exploit benthic invertebrates (Hale 1980) which are easily sampled to estimate prey densities. In Britain, eighteen species of wading bird winter in coastal habitats (Prater 1981). Only nine of these may be classed as common, with total British (excluding Eire) populations in excess of 10,000 individuals (Table 2).

Of these, Turnstone (Arenaria interpres L.) are restricted to rocky shores where visibility can be impeded, whilst Lapwing (Vanellus vanellus L.) and Golden Plover (Pluvialis apricaria L.) use the estuarine habitat predominantly for roosting. Dunlin (Calidris alpina L.) and Knot (Calidris canutus L.) were unsuitable because their foraging habits (Goss Custard et al ,1977) made detailed observations of feeding behaviour difficult. Bar-tailed Godwit (Limosa lapponica L.) were eliminated because the population of the mid-estuarine Firth of Forth (section 2.2) is highly mobile (Bryant 1978) and numbers only 300-350 individuals (Bryant 1979, Bryant 1980, Warnes et al 1980).

Redshank (Tringa totanus L), Curlew (Numenius arquata L.) and Oystercatcher (Haematopus ostralegus L.) were all suitable as they are easily observed and common on the mid-estuarine Forth (Bryant 1979, 1980). Redshank and Oystercatcher were selected for study.

Table 2

Common wading birds wintering in coastal habitats in Britain, with their populations (excl. Eire) - after Prater 1981.

| | Species | Population (k) |
|-------------------|----------------------------------|----------------|
| Oystercatcher | (<u>Haematopus ostralegus</u>) | 250 |
| Lapwing | (<u>Vanellus vanellus</u>) | 210 |
| Golden Plover | (<u>Pluvialis apricaria</u>) | 170 |
| Turnstone | (<u>Arenaria interpres</u>) | 15 |
| Curlew | (<u>Numenius arquata</u>) | 90 |
| Redshank | (<u>Tringa totanus</u>) | 70 |
| Bar-tailed Godwit | (<u>Limosa lapponica</u>) | 60 |
| Knot | (<u>Calidris canuta</u>) | 300 |
| Dunlin | (<u>Calidris alpina</u>) | 600 |

(2 2) Selection of study sites

Observations were made on the mid-estuarine Firth of Forth, Scotland. A pilot study (Table 3) in mid-winter 1980/81 evaluated eleven sites for the study of Redshank (Fig. 4 - sites A-K), and three sites for the study of Oystercatcher (Fig. 4 - sites L-N). Sites B and E were selected for the study of Redshank and site L for the study of Oystercatcher. At these sites the study birds were abundant and easily observed, and collecting mud samples required less effort because the access points were relatively close to the mud-flats.

(2.2.1) Details of study sites(a) Site B, Skinflats (Kincardine Bridge). (NS 923867)

The flat was divided into seven one hectare plots by reference to salient features and marker sticks on the mud (Fig. 5). A hide was erected 17m from the edge of the mudflat in February 1981.

(b) Site E, Culross (Longannet). (NS 975857)

The flat was divided into twelve one hectare plots, as above (Fig. 6).

(c) Site L, Culross (Ola Pier) (NS 975858)

There are two mussel beds at Culross (Fig. 6), the upper and lower beds. The lower bed is 1000 x 75m, the upper bed is 700 x 100m. Four plots were established on the upper bed and five on the lower bed. Plots were 75m wide and separated by distances of 75 to 100m.

(2 3) Study periods

Parameters of the model (section 1.2) may vary seasonally. Observations were therefore made over six week periods, during which it was assumed parameters were stable. The study periods were as follows.

Table 3

Results of pilot study evaluating 15 sites as potential study sites.

| Site (see Fig. 4) | Name | to access (m) | Distance to laboratory (km) | to birds (m) | n birds at site n |
|----------------------------|----------------------------|---------------------|--------------------------------------|--------------------|-------------------------|
| <u>Redshank Sites</u> | | | | | |
| A | Kennet pans | 50 | 12 | 50 - 150 | 40 |
| B | Skinflats (Kincardine) | 400 | 14 | 20 - 200 | 400 |
| C | Skinflats (Grangemouth) | 150 | 17 | 150 - 500 | 400 |
| D | Holme Farm pond | 400 | 17 | 20 - 70 | 10 |
| E | Culross (Longannet) | 20 | 15 | 40 - 200 | 70 |
| F | Kinniel | 300 | 23 | 100 - 700 | 250 |
| G | Boness | 10 | 26 | 50 - 100 | 30 |
| H | Torry Bay (Valleyfield) | 150 | 24 | 200 - 600 | 40 |
| I | Torry Bay (Crombie) | 20 | 25 | 300 - 600 | 100 |
| J | Blackness (West) | 50 | 40 | 300 - 400 | 30 |
| K | Blackness (East) | 500 | 40 | 100 - 500 | 60 |
| <u>Oystercatcher Sites</u> | | | | | |
| L | Culross (Old pier) | 50 | 16 | 50 - 100 | 130 |
| M | Torry Bay (Torry burn) | 30 | 24 | 200 - 600 | 110 |
| N | Torry Bay (Crombie) | 20 | 25 | 300 - 600 | 70 |

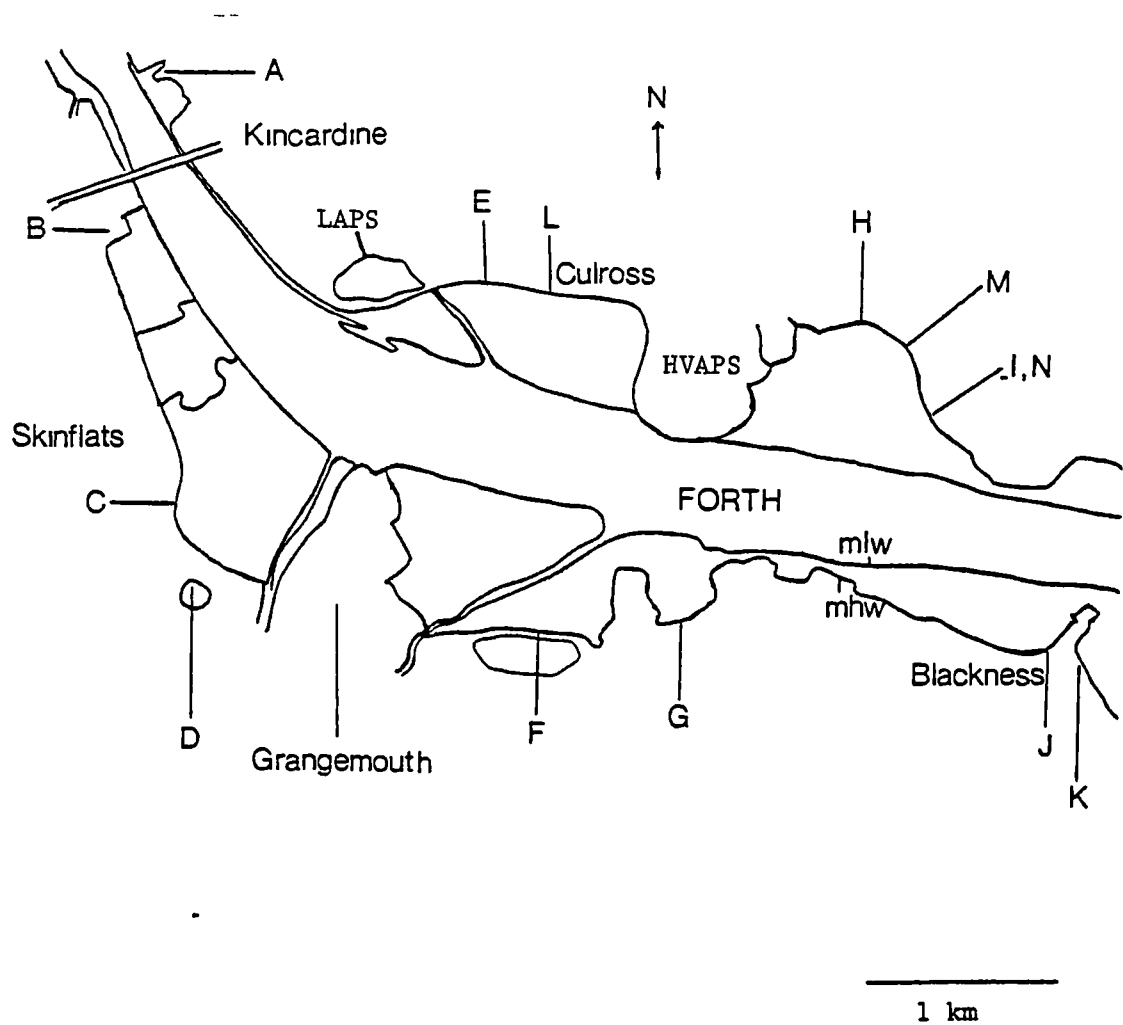

Fig 4 The mid-estuarine Firth of Forth, Scotland, with positions of sites (A to N) visited during the pilot study (section 2 2)

See Table 2 for details of sites

LAPS - Longannet ash pans

HVAPS - High-valleyfield ash pans

mlw - mean low water

mhw - mean high water

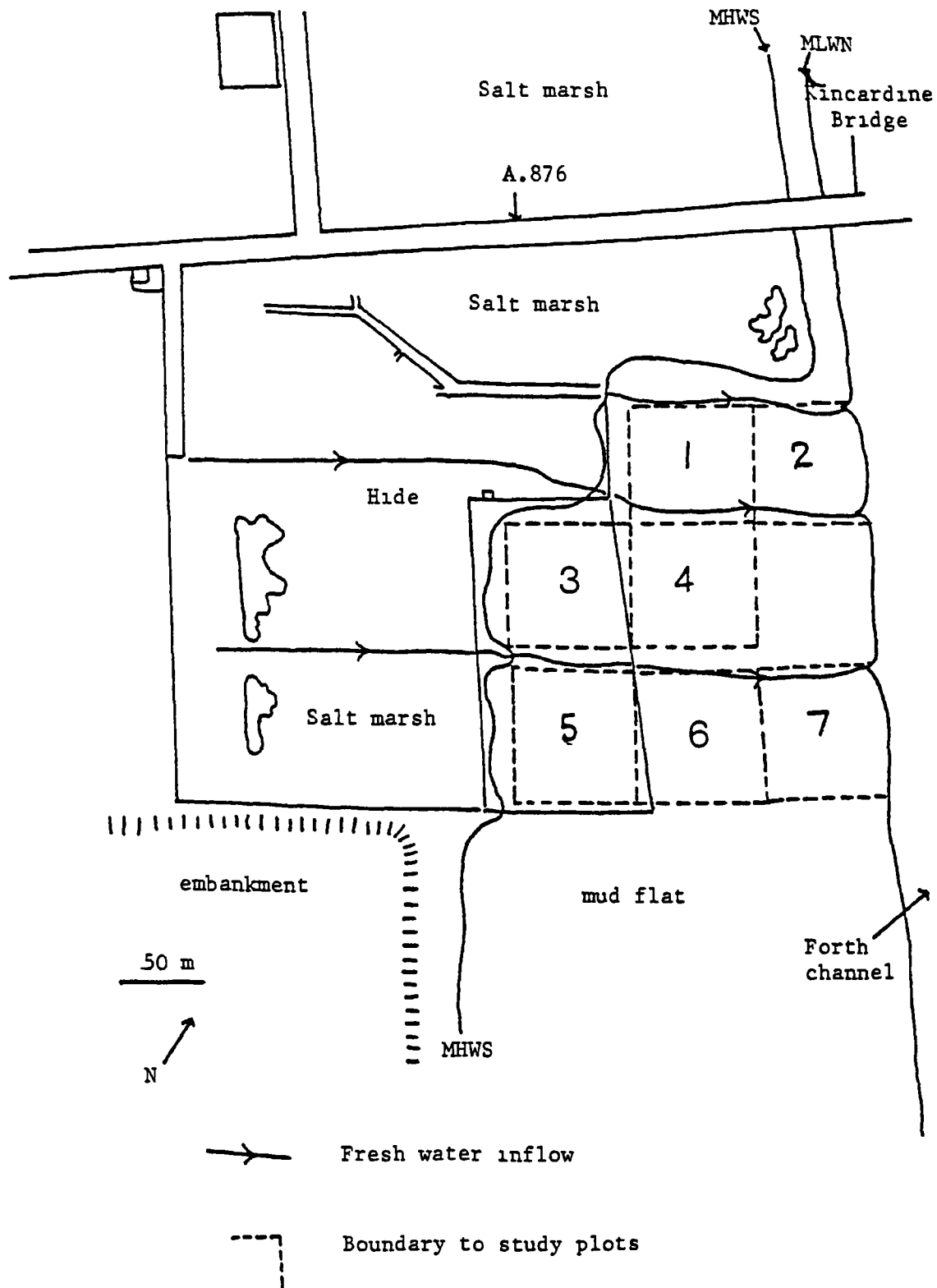

Fig 5 Details of site B, Skinflats, Kincardine Bridge The seven study plots are numbered
 MHWS - Mean high water springs
 MLWN - Mean low water neaps

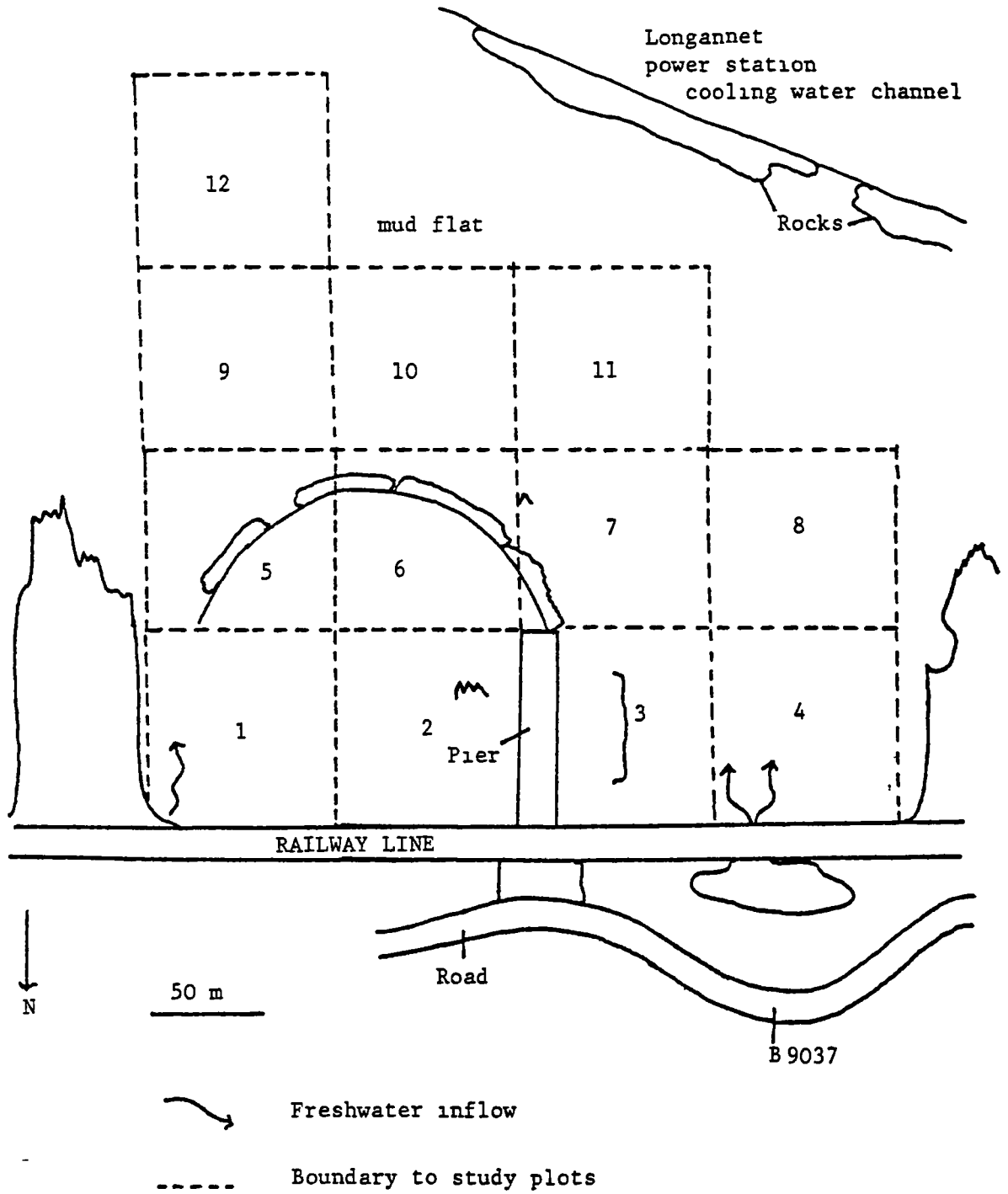

Fig 6 Details of study site E, Culross, Langannet. The twelve study plots are numbered

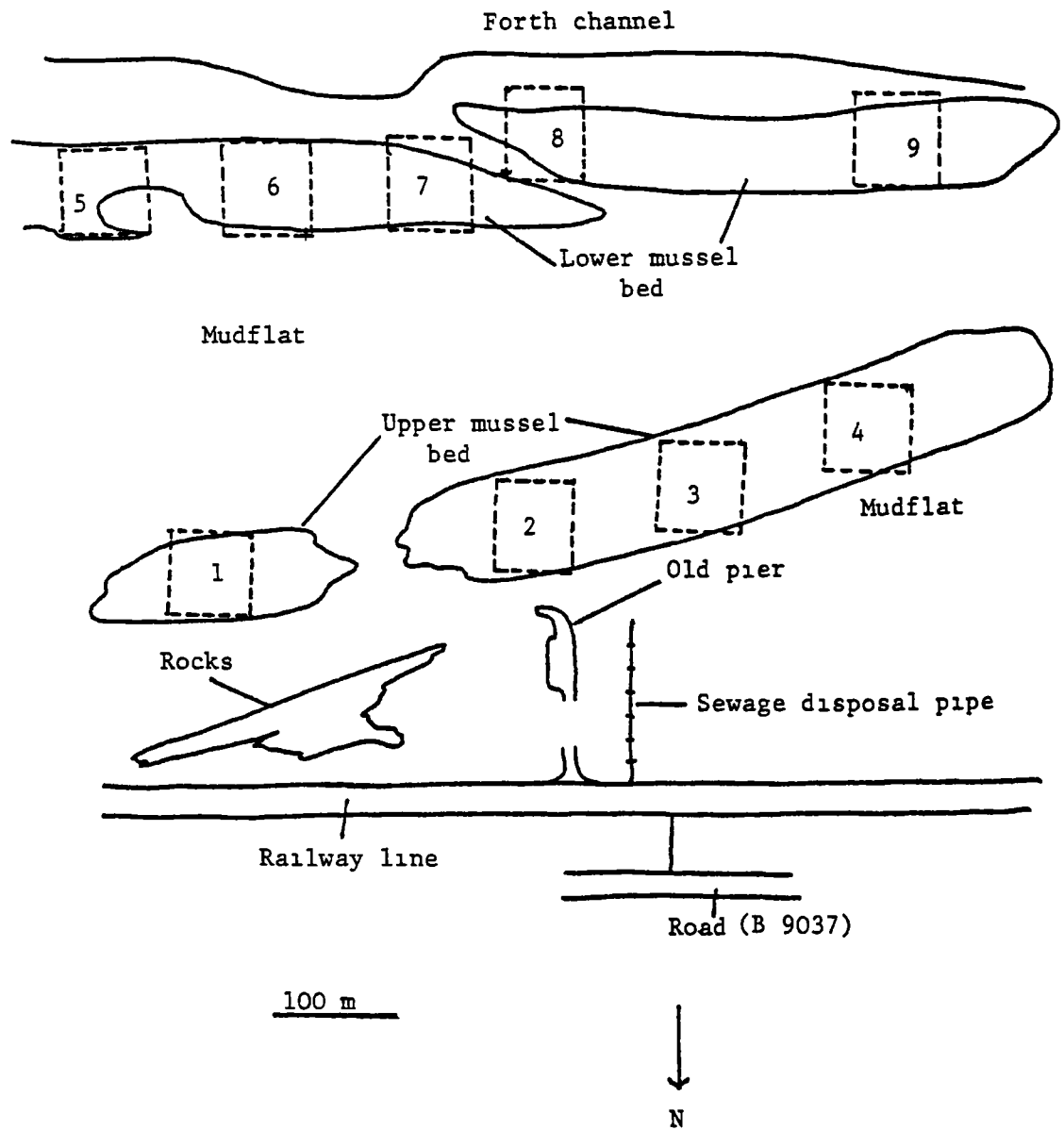

Fig 7 Details of study site L, Culross, Old Pier The nine study plots are numbered

| | |
|--------------|-------------------------------|
| Autumn | 14th August to 30th September |
| Early winter | 20th October to 7th December |
| Late winter | 14th January to 1st March |
| Spring | 21st March to 7th May |

Observations were made in Spring 1981 and throughout winter 1981/82.

(2.4) Statistics

All regression equations were fitted by the method of least squares. Differences and relationships were judged significant where p was less than .05

PART TWO - Model parameters

(2.5) Prey density

(a) Redshank prey

Densities of benthic invertebrates were estimated by sampling the mud using cores. At the end of each study period (section 2.3) ten samples were collected from each plot at each site (section 2.2), five at each of two randomly selected positions. At each position the location of the first sample was randomized, the subsequent four were collected in a line, spaced 20cm. apart. The square core had a side of 5cm. Samples were taken to a depth of 6cm., the maximum depth to which Redshank are observed probing in the field.

Samples were sieved in the laboratory (300 μ m.), sieving in the field was not possible. Retained animals were removed, identified and measured along a single allometric variable, shell length in Hydrobia ulvae, shell width and Macoma balthica, and body length in Corophium volutator and Polychaetes (Appendix 1). Oligochaetes were counted but

not measured Densities were estimated per m²

Although the sampling procedure was adequate to estimate the densities of most invertebrates, it was probably not adequate to estimate the density of Polychaetes, which may be available but retract up to 30cm into burrows during sampling (Goss Custard 1973, Muus 1976) On the Forth burrows seldom exceed 15cm long (McGraw pers comm) A less intensive survey (two 10cm² x 15cm deep samples at selected plots) was performed to estimate the density of Polychaetes These samples were sieved over a 1mm sieve and all the retained Polychaetes were measured in length

(b) Oystercatcher prey

At the end of each study period (section 2 3) eight samples were collected at each plot over mussel clumps on both the upper and lower beds (section 2 2 1 (a)) The square core had a side of 10cm Samples were taken to a depth of 15cm, or until rock was reached In the laboratory, samples were sieved over a 1mm sieve and all the live mussels were retained Percent coverage of Barnacles (Balanus sp) was estimated, by eye, to the nearest 5%, shells were then washed, cleared of barnacles, and blotted dry Shell length, height and width (Appendix 1) were all measured

The coverage of mussels was estimated by throwing twenty 50cm x 50cm quadrats in each plot Coverage within each quadrat was estimated by eye.

(2 6) Prey Availability

(a) Definition of availability

Prey availability was defined for each prey in respect of a given predator and the search strategy employed

(1) Visually searching Redshank

Visually searching Redshank can only detect prey present in whole or part at the mud surface or buried items which leave surface cues revealing their presence Hydrobia ulvae spend the low tide period on or below the mud surface (Thamdrup 1954, Vader 1964, Little and Nix

1976) Where the mud surface is firm they leave burrows as they descend into the mud (Barnes 1981) Hydrobia were defined as available when present at the mud surface, and when burrows revealed their presence below the surface.

Corophium volutator spend the low tide period in burrows below the mud surface. When feeding they extend the antennae and head above the mud surface and draw surface detritus into the burrow (Meadows and Ried 1966) - a feeding excursion. Corophium were defined as available when exposed at the surface feeding, or when burrows revealed their presence below the surface.

Macoma balthica spend most of the low tide period buried in the mud (Yonge 1949), although very occasionally gaping shells are noted at the surface (pers. obs.). Two siphons extend from the buried bivalve, one inhalent and one exhalent. The position of the inhalent siphon is generally marked by a depression in the mud, or small surface tracks (Hulsher 1973), whilst the exhalent is undetectable or marked by a roughly circular area of sieved mud upto 6mm. in diameter (Yonge 1949). These surface cues can only be reliably identified, by humans, on the Forth, when the siphons are active. Macoma were therefore defined as available when siphon activity was observed at the surface.

Nereis diversicolor also spend the low tide period below the mud surface in burrows (Thamdrup 1954, Vader 1964). When feeding the worm extends from the burrow vertically, and plunges the extended pharynx into the mud adjacent to the burrow several times before retracting (Trevor 1977) This behaviour often leaves no surface cues at all. On the Forth, Nereis were defined as available when exposed at the surface.

(ii) Reliability tests of surface cues

Twenty 1cm. diameter cores were collected to a depth of 5cm. around burrows presumed to be Hydrobia ulvae or Corophium volutator, and

randomized on the mud surface. Samples were sieved over a 300um sieve and all the retained animals were identified.

(iii) Tactile searching Redshank

Tactile foraging Redshank move the beak rapidly through the upper surface layers of mud to a depth of about 2cm. - termed swishing (Goss Custard 1969, Buxton 1975). Any prey item present at the surface or in the top 2cm. of mud was defined as available.

(iv) Oystercatcher

Ens (1982) has suggested Oystercatchers foraging on mussels may be tactile feeding. However, Oystercatchers do not probe the bill continuously when foraging on mussels, which is characteristic of tactile foraging methods e.g. Dunlin - stitching, Redshank - swishing and multiple pecking in Oystercatchers tactile feeding on Macoma (Hulsher 1982). This would suggest they are foraging visually. A mussel was therefore assumed to be available when any part of its shell was exposed, i.e. could be detected by visually searching predators.

(b) Measurement of availability

(i) Visually searching Redshank

Benthic invertebrates were observed from an air bed, allowing continuous observation without disturbance. Between five and eight square quadrats (10cm^2) were marked out at the head of the bed on arrival. Observations were started half an hour later, and continued at half hour intervals

In each observation set the number of Hydrobia in whole or part at the surface, and number of Hydrobia and Corophium burrows in each quadrat were counted. Each quadrat was observed for three periods of one minute. In each period the number of feeding excursions by Corophium and Nereis were counted. Siphon activity of Macoma was estimated as siphon minutes per minute observed. At the end of each observation set

the mud and air temperatures were measured. A surface mud sample was collected, to assess the surface water content, and sealed in a glass tube. Estimates of the duration of Corophium and Nereis feeding excursions were made between observations. Observations were made on seven separate tides across the temperature -2° to 17°C .

At the end of each day's observations, a mud sample was collected over each marked quadrat to a depth of 15cm. This was divided into the top 6cm. and the remainder. The top 6cm was processed as small samples (section 2.5) and the remainder as large samples (section 2.5).

(ii) Tactile searching Redshank

Samples were collected at three separate sites, on two tides, at Skinflats, in Early Winter 1981. At each site 15 samples measuring 5 x 5 cm in area were collected from randomized locations within a square metre. Five samples at each depth 1, 2 and 6cm. Samples were sieved over a 300 μm sieve and all the retained animals were removed, identified and counted.

(iii) Oystercatcher

Four mussel clumps, at Culross plots (2) and (3), measuring approximately 15 x 15 cm were sprayed from all aspects from a distance of 5cm. with white spray paint. The clumps were left 15 min. to dry, and were then removed from the substrate and returned to the laboratory, where individual mussels were separated. Each mussel was measured in length (Appendix 1) and the coverage of paint, Barnacles, and both paint and Barnacles was estimated to the nearest 5%, by eye.

(2.7) Foraging path width

A searching wading bird can only capture and ingest those prey within the maximum distance the bird can reach. The distance was called the foraging path width (x in model, section 1.2). Visually searching

VISUAL

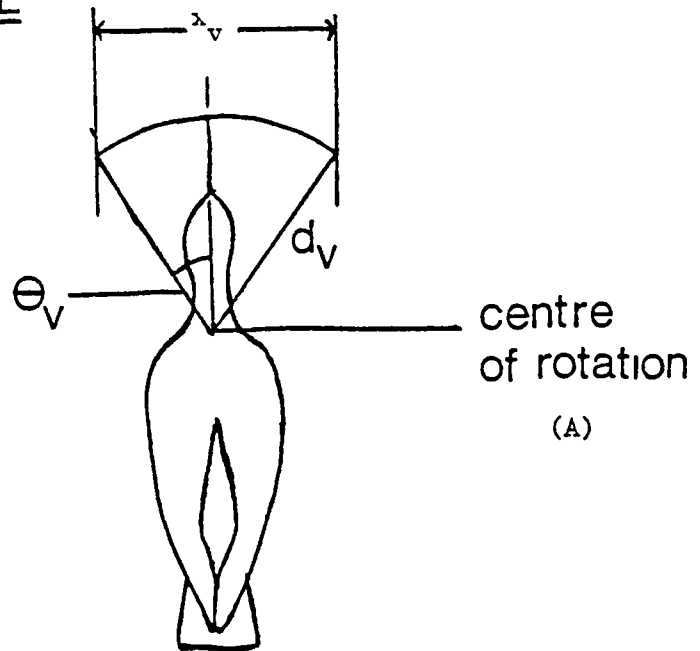

TACTILE

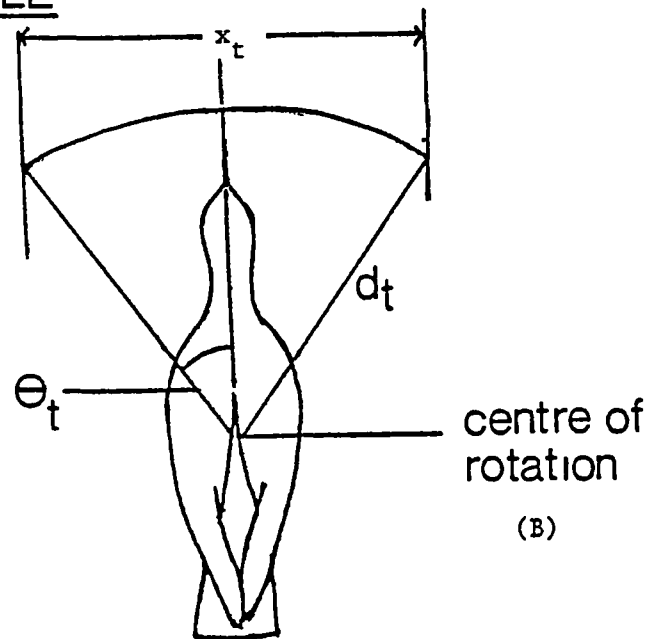

Fig 8 The centres of rotation, angles of rotation (θ), distances from rotation centre to beak tip (d) and foraging path width (x) in visual and tactile foraging Redshank (dorsal view) The foraging path width (x) is described by the following equation

$$x = 2d \sin\theta$$

Since the centre of rotation is further forward in the visual forager (A), the distance d_v is shorter than d_t and therefore $x_v < x_t$

Redshank walk forwards and peck to either side of the path centre (Fig 8) The major centre of rotation is the anterior end of the sternum (A). However, tactile searching Redshank are stationary when sweeping the bill through the surface layers, and the major centre of rotation is the centre of gravity - between the legs (B). The foraging path width of tactile foraging Redshank is consequently wider than when the birds forage visually.

In Redshank, foraging path widths were estimated directly by visually estimating the values θ_t , θ_v , d_t , and d_v and indirectly by measuring the depletion of prey around foraging paths in the field.

(a) Direct estimate - Redshank

Nine captive Redshank were observed foraging on Blowfly larvae (Calliphora sp.) and pupae spread on the ground of an indoor aviary (section 2.15(b)). The distances d_v and d_t and angles θ_v and θ_t were estimated to the nearest cm and 5° respectively in birds feeding whilst walking (visual values) and stationary (tactile values). The visual search path width was estimated as $2d_v \sin \theta_v$, and the tactile search path width as $2d_t \sin \theta_t$.

(b) Indirect estimate - Redshank

Fresh Redshank footprints were located on the mudflat surface at Skinflats where the birds feed exclusively visually, within four hours of tidal emersion, on four tides in Spring (section 2.3). On each of several distinct paths surface quadrats measuring 5 x 5 cm were marked with the quadrat centre at 0, 2.5, 7.5, 10 and 12.5 cm away from the path centre. In each quadrat the number of Hydrobia available to visually searching Redshank (section 2.6(a)), excluding those in burrows were counted. A relationship was established between the distance from the path centre and Hydrobia availability.

The foraging path width was calculated as the distance containing 95% of

the deficit in Hydrobia compared to the availability at 12 5cm.

(c) Oystercatcher - Direct estimate

Oystercatchers appear to search visually (section 2 7(a)(iv)). The major centre of rotation is therefore the anterior end of the sternum (section 2.5.3). The distance d_v and angle θ_v were estimated in captive Oystercatchers feeding on blowfly pupae in an outdoor aviary. The foraging path width was calculated as for Redshank (section 2.7(a)) Field estimates for Oystercatcher were not possible as footprints were rarely found on the mussel beds.

(2.8) Prey energy content

All tissues are generally recognized to be divisible into three components - water, inorganic matter and organic matter (Klieber 1961). Animals obtain energy by the oxidation of the organic component. The energy content equals the organic content multiplied by the calorific value of the flesh. This was calculated across the allometric variable along which prey items collected to estimate density were measured (section 2.5.1), for all prey species.

(a) Redshank

Samples of each prey were selected from the items collected to estimate prey densities (section 2.5) for all plots at each site (section 2.2), in each study period (section 2.3). Each item was measured (Appendix 1) and dried in a small aluminium crucible at 60°C to constant mass (between 10 and 14 days) (Elliot 1979, Warnes 1981). The dry animal and crucible were weighed and then heated to 450°C in a muffle furnace for 24 hrs to oxidize the organic component. The remaining ash and crucible were reweighed. The 'Official Methods of Analysis' (1955) (In Klieber 1961) were not adopted because the drying period (3 hr) was not sufficient to evaporate all water from these

samples (Warnes 1981), the drying temperature (105°C) possibly results in some oxidation of organic matter, whilst the ashing temperature (800°C) may result in volatilization of potassium and calcium (Rees 1937). Oxidation of the crucibles was not significant with either treatment. Organic content was estimated as the ash-free dry mass (AFDM).

Estimates of biochemical composition and calorific content were made for all prey in both early and late winter. Between 20 and 50 animals across all sizes were dried in an oven at 60°C for 10 days. The dried animals were ground in a mortar. Carbon, Nitrogen and Hydrogen contents of two 1-1.5mg samples from the resultant homogenate were estimated using a Perkin Elmer CHN Analyser.

The % protein was calculated at 7.5 x the % Nitrogen (Klieber 1967). Assuming 53.5% of the protein was carbon (Klieber 1967) the percentage of carbon present as other forms, called the % residual carbon (RC), was calculated. The % residual oxygen (RO) (= oxygen not in protein), was calculated as follows

$$\% \text{ RO} = 100 - (\% \text{ protein} + \% \text{ RC} + \% \text{ Hydrogen})$$

Assuming all the residual oxygen to be present as carbohydrate the % carbohydrate was calculated as $1.875 \times \% \text{ RO}$ (= molecular Wt $\text{C}_6\text{H}_{12}\text{O}_6$ / molecular Wt O_6). The % LIPID was obtained from the difference between the sum of protein and carbohydrate fractions and 100%.

Energy contents (kJ.g AFDM^{-1}) were estimated using two methods.

- (a) The biochemical composition was converted to energy content using the calorific equivalents - Protein = 23.82 kJ.g^{-1} , Carbohydrate = 17.13 kJ.g^{-1} and Lipid = 39.71 kJ.g^{-1} (Brody 1945, Klieber 1967, Winberg 1971).

(b) Percent organic carbon was converted to energy content using the empirical relationship derived by Salonen et al. 1977.

(b) Oystercatcher

Samples of mussels, representing the whole range of prey sizes, were selected from the samples collected to estimate prey density (section 2.5), from each plot at the study site (section 2.2.1(c)). Barnacle coverage was estimated to the nearest 5%. Each mussel was cleared of Barnacles, washed, dried and the shell length, width and height measured (Appendix 1). Mussels were opened by inserting a scalpel blade at the dorso/posterior margin and severing the posterior adductor muscle. The flesh was removed, blotted dry, and weighed wet in an aluminium crucible of known weight.

The inside of the shell was blotted dry and it was weighed. The dimensions of the posterior adductor muscle scar (Appendix 1) were measured. Energy content of some samples was estimated as for Redshank prey. AFDM was estimated as above (section 2.8(a)).

(2 9) Assimilation efficiency

Not all the energy content is available to an animal because the enzymes necessary to digest all organic substrates are not present in all animals. The amount of energy assimilated, as a proportion of that ingested, is called the assimilation efficiency. Estimates of assimilation efficiency are generally made by mixing the food with an inert marker (normally Chromium oxide - Crampton and Lloyd 1951). As the marker is indigestible, the increase in its proportion between the food and faeces is a result of assimilation of some of the food. The assimilation efficiency can be calculated as -

$$\text{Assimilation efficiency} = I - c_f/c_{fe}$$

where c_{fe} and c_f is the concentration of marker in the food and faeces respectively (Edin 1926). Although the marker is itself indigestible, its effect on the digestibility of the organic portions of food is unknown. If the inorganic portion of the food is not assimilated it could be used as a natural marker.

Estimates of assimilation efficiency were obtained for Redshank feeding on Blowfly larvae, Blowfly pupae, sardines (Sardina pilchardus) and Hydrobia and for Oystercatchers feeding on mussels and Blowfly pupae, by estimating the inorganic ash content of the food and faeces.

Four wild-caught Redshank (section 2.15(a)) were kept in an outdoor aviary (section 2.15(b)). All the faeces in the aviary were removed and the experimental food was introduced. Birds were fed on this food for a minimum of two days prior to any collection of faeces. On the third day, or later, samples of fresh faeces were collected from the logs and stones on which the birds often roosted, this avoided any collection of inorganic matter from the ground of the aviary. Ash content of the samples of food and faeces was estimated as above (section 2.8). Identical procedures were used with two Oystercatchers kept individually and fed opened mussels and Blowfly larvae.

Validity test that ash is not assimilated

Two hand-reared Redshank were kept in an indoor aviary measuring 2m. x 1.5m., at a temperature of 20 °C. Measurements were made of food intake and simultaneous fecal production over three independent periods of 24 hrs. The birds were deprived of food, but not water, for a period of one hour prior to measurements. This was considered an adequate time for the birds to clear their guts. A plastic sheet, of known weight, was placed on the aviary floor, and a weighed quantity of sardines in edible oil was introduced in a feeding tray. Water was administered ad

lib In total the food and water tray occupied only 1% of the total floorspace. There was no evidence after any of the three trials that feces had been deposited in these trays. A weighed tray of identical food was also placed in the room where the birds could not gain access to correct for evaporative water loss in the food. After 24 hrs., 16 of which were spent in total darkness, the food was removed and both trays weighed. An hour later the plastic sheet was removed and reweighed.

Samples of food and feces were dried and ashed as above (section 2.8). The intake of ash was calculated as the food intake, corrected for evaporative water loss, multiplied by the ash content of the food. Similarly, the ash output was calculated as the weight of feces produced multiplied by the ash content of the feces.

(2 10) Incomplete ingestion

All the prey ingested by Redshank are ingested whole. However, Oystercatchers often leave small amounts of flesh in the shells, generally the stub of the adductor muscle and the mantle edge running along the ventral margins of the shells. Observations of captive Oystercatchers suggest these remains are left in approximately 85% of mussels. Sutherland (pers.comm.) found flesh remains in all mussels opened by captive Oystercatchers. Warnes (1981) observed Redshank following Oystercatchers and extracting this flesh from cockles (Cardium edule) at Kinniel (Fig. 4). Redshank extracted flesh from all the abandoned shells (pers.comm.) suggesting flesh is left in all shells in the field and total clearance in captivity is a result of revisiting shells, which is unlikely in the field. It has been assumed therefore that flesh remains are left in all mussels opened in the field.

The quantity of this flesh was measured in 30 mussels, between 4 and 7 cm long (Appendix 1), collected across the plots in late winter.

These were opened as in section 2.8(b) and the flesh was divided into two components - the margin of the mantle on the ventral surface with stubs of the adductor muscle and the remainder. These were dried and ashed independently (section 2.8). The AFDM of the mantle and adductor stubs was expressed as a proportion of the total AFDM.

(2.11) Handling times

(a) Redshank

Focal Redshank were observed ingesting prey items at plots 2 and 3 at Skinflats (section 2.2.1(a)) and plots 1-6 at Culross (section 2.2.1(b)), across all four study periods (section 2.3), using a tripod-mounted telescope. Prey were classified into one of nine classes (section 2.17.2) by comparison to the bird's bill and eye (see section 2.17.2(a)i) for reliability test of classification procedure). Handling times were estimated directly using a stopwatch, or indirectly by dictating the behaviour onto a cassette tape recorder, and subsequently timing with a stopwatch. Because the handling times for all prey were short the handling time was not divided into components (section 1.2).

(b) Oystercatcher

Oystercatchers handle mussels using different techniques. Evans (1977) observed Oystercatchers eating small mussels whole. However, it is more common for them to open mussels. Norton Griffiths (1967) distinguished 'hammerers' which direct blows at exposed shells to break them open, and 'stabbers' which stalk slightly open mussels in shallow water. This classification was extended by Goss Custard et al. (1980) who divided 'hammerers' into those directing blows at the dorsal surface, and those directing blows at the ventral surface. At Culross the majority of Oystercatchers open mussels by forcing the beak against the dorso-posterior margin moving the head from side to side and sometimes

rotating completely around (pers.obs., Warnes 1980). There is a small hammering population.

Adult Oystercatchers (distinguished from immatures by the complete orange bill - Prater et al. 1977) were observed foraging on both mussel beds at Culross (section 2.2.1(c)) across all four study periods (section 2.3), using a tripod mounted telescope. All prey ingested by Oystercatchers on the mussel beds were mussels. Mussel length was estimated to the nearest 0.5 cm by comparison with the bird's beak. Handling behaviour was divided into recognition, manipulation - prizing or hammering, and ingestion and dictated onto a cassette tape recorder. Times were subsequently estimated using a stop-watch. Some direct estimates were also made using two stopwatches, timing cumulative handling time on one watch and ingestion time on the second.

(c) Reliability test of size estimates

Observations were made of mussels held in tongs by an assistant seated 100m. away, using the same optical equipment as in handling behaviour observations (above). All mussels were held in view for 2 s. Mussels were selected at random from 24 items between 0.6 and 6.5 cm long. Mussel length (Appendix 1) was estimated to the nearest 0.5 cm and compared with the actual length.

(2 12) Occurrence and duration of failed handling attempts

(a) Redshank

(i) Unsuccessful manipulation

The only prey Redshank abandon during manipulation are crabs (pers obs.), and Nereis (Goss Custard 1976). These events were so rare that it was not feasible to observe birds until they occurred. Estimates of occurrence and duration were obtained from observations made to evaluate diet choice (section 2.17.2).

(ii) False recognition

Redshank often make pecks at the mud which are unsuccessful. These are presumed to be pecks at misidentified surface cues (section 2.6), and are consequently called false recognitions. False recognitions were timed directly using a stopwatch. The rates at which false recognitions occurred was estimated in relation to the rate of successful pecks for other items by estimating the number of both events occurring in short time periods (40-50 s.).

(iii) Kleptoparasitism

Redshank are kleptoparasitised by Common gulls (Larus canus L.) (Hamilton and Nash 1928). Intra-specific kleptoparasitism has not been described. Kleptoparasitic events were very rare and consequently occurrence and duration were estimated from observations to establish diet choice (section 2.9.2).

(b) Oystercatcher(i) False recognitions and unsuccessful manipulations

When handling prey, Oystercatchers make a number of investigative taps with the bill before initiating manipulation. These investigative probes were presumed to be recognition behaviour. False recognitions, where the searching bird stopped walking, probed at a mussel and then continued, and unsuccessful manipulations where the bird initiated an attack but subsequently abandoned it with no energy gain, were common. The rates of occurrence and duration of these behaviours were estimated by dictating all the birds' behaviour over 10 min. periods onto cassette tape and subsequent timing with a stopwatch.

(ii) Kleptoparasitism

Oystercatchers are intraspecific kleptoparasites (Goss Custard 1980, Vines 1981). They are also kleptoparasitised by Herringgulls (Larus argentatus L.) and Hooded/Carrion crows (Corvus corone L.) (Zwarts 1978,

Ens pers. comm , pers. obs.). Estimates of the duration and occurrence of such kleptoparasitisms were made from the above tapes (section 2.12(b)i).

(2 13) Energy cost of searching

(a) Visually searching Redshank

Estimates of energy expenditure are commonly made while trained birds walk on a conveyor belt enclosed within a respirometry chamber or within a sealed treadmill (Fedak et al. 1974, Taylor 1979), or by forcing birds to walk for long periods in these apparatus and estimating increases in food consumption (Kontogiannis 1968). All these methods involve the birds walking for long periods and, especially at high speeds, birds are often reluctant to walk continuously and display other behaviours (e.g stopping and flapping, up to 60% of the time). These behaviours affect the estimate of energy expenditure for walking (Speakman 1980)

Woakes and Butler (1983) have developed a system of estimating energy expenditure over much shorter periods in diving ducks, which depends on measuring changes in the concentration of gases in the outflow stream of a respirometer. With this method, to ensure perfect mixing in the chamber, a fan blows air over the birds, which probably increases convective heat loss and therefore energy expenditure.

Tucker (1968, 1972), Butler (1971), Thomas and Struthers (1972), and Szytk et al (1977) have successfully used close fitting masks to collect respiratory gases from a wide range of exercising animals. This technique enables an almost instantaneous estimate of metabolism, and often estimates of respiratory frequency, because the equilibrium volume is so small (see section 2 16(b) for criticisms of technique). Two hand reared Redshank were trained to walk in a rotating treadmill respirometer

(Speakman 1980) whilst wearing a cellulose acetate mask (total weight = 0.6 g). Respiratory gases were extracted from the mask via a 60 cm. length of narrow gauge Portex tubing at a rate of 2 l. min^{-1} . The gas was dried by passing through a Calcium chloride filter, and then filtered to remove any dust. The concentration of CO_2 in the extracted gas was measured using an Infra-red gas analyser (Pfund and Gemmill 1940, Spoor 1948) (Mine Safety Instruments Ltd.). The concentration of O_2 in the extracted gases was estimated by sub-sampling the gas stream at a lower flow rate (300 ml. min^{-1}) using a Beckman Polarographic Oxygen analyser. The flow was measured using a cumulative gasometer (see Fig. 9).

Birds were weighed prior to experimentation but were not food deprived. The calcium chloride was weighed and the gas analysers calibrated using N_2 , 1% CO_2 in N_2 (CO_2 analyser) (BOC (Special Gases) Ltd.) and room air (20.94% O_2 Carpenter 1937) (O_2 analyser). The mask was placed on the bird and it was introduced into the treadmill. Birds were allowed to settle for 20 min. prior to any observations. The treadmill was rotated at speeds between 15 and 40 cm. s^{-1} . The treadmill was started slowly and built up to the required speed over the next minute to minimize the startle response (Marconi et al 1982). Birds were run for periods of 12-15 minutes. There was no evidence of any progressive change in the metabolism over this period. Records were made every minute after the first minute. If the bird showed excessive non-walking behaviours the run was ended. Birds were observed when walking, the number of paces per drum rotation and the time per rotation were measured. Birds were allowed to rest for 10 minutes between runs. Three walks at different speeds were made in each session. The bird was then removed and reweighed. Observations were made at 15 and 20°C. All gas volumes were corrected to S.T.P.

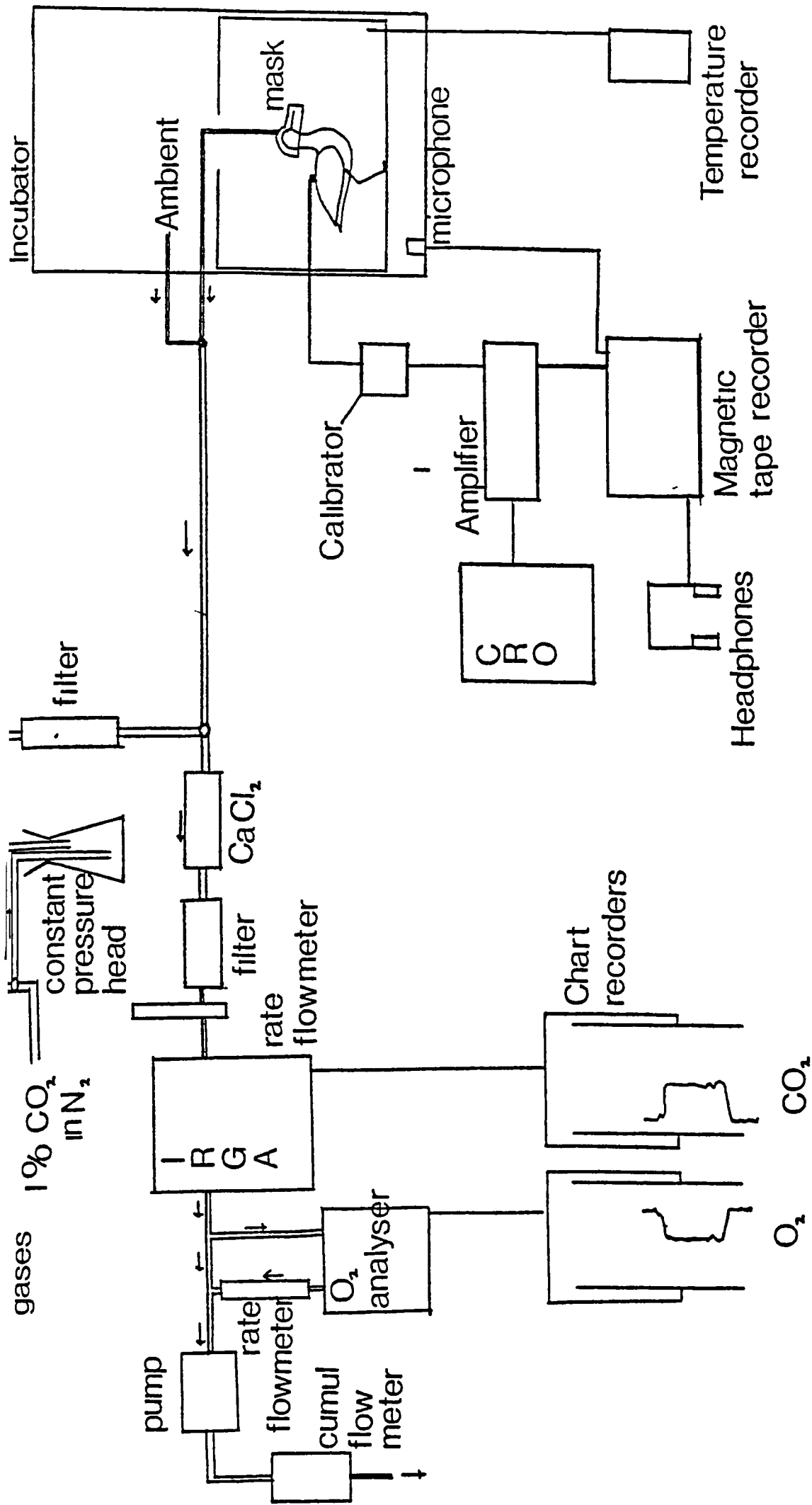

Fig 9 Apparatus used for simultaneous estimates of metabolism and heart rate. Arrows indicate the directions of gas flow. Solid connections indicate electrical connections. IRGA = infra-red gas analyser. CRO = Cathode ray oscilloscope. Magnetic tape recorder.

(273°K and 760 mm Hg).

See also section 2.15 for estimate using heart-rate telemetry.

(b) Tactile searching Redshank

Although the mask technique allowed almost instantaneous estimates of metabolism, it was not possible to use it to estimate the energy expenditure of tactile searching Redshank because the mask would interfere with the behaviour and it would be difficult to induce the birds to perform the behaviour in a respirometer. Estimates were therefore obtained by heart-rate telemetry only (section 2.15).

(c) Oystercatcher

Estimates of energy expenditure in hand reared Oystercatcher walking in an open flow respirometry system were obtained from Speakman (1980).

(2.14) Energy cost of handling prey

Estimates were not possible in either species using the mask technique (see section 2.13(b)). Estimates were obtained by heart-rate telemetry (section 2.15).

(2.15) Radio-telemetric studies of metabolism

When an endotherm experiences increased energy demand it increases the rate at which oxygen is supplied to both the metabolising tissues and the lungs. Within the circulatory system there are three potential mechanisms of increasing oxygen supply to muscles - increasing heart-rate, stroke volume, or the efficiency with which oxygen is extracted from the blood, (the $[Cv_{O_2} - Ca_{O_2}]$ difference) Within the respiratory system there are two mechanisms - increased respiratory frequency or tidal volume. Theoretically, any of these variables might be well correlated with metabolism, however, at present it is only possible to radio-telemeter respiratory frequency, by inserting a

thermistor into the lumen of the trachea, and heart-rate, E C.G.

Szylk et al. (1977) have demonstrated a non-linear relationship between respiratory frequency and metabolism, in exercising dogs (Canus familiaris). Similar non-linear relationships have been reported for Humans (Homo sapiens), Pernoll et al. (1975), Hesser et al. (1977), and Pigeons (Butler et al. 1977) In addition, Butler and Woakes (1976) encountered practical difficulties with implanted thermistors because of tracheal secretions. In contrast the relationship of heart-rate to metabolism is linear in many species across a wide range of metabolisms (Owen 1969, Morhadt and Morhadt 1971, Gessaman 1973, Ferns et al. 1979, Woakes and Butler 1983), and was therefore considered most suitable for this study.

(a) Study birds

Eight adult Redshank were captured from the wild and kept in an outdoor aviary (section 2.15(b)). Four birds were captured from the East coast of Scotland at Dunbar and four from the Inner Clyde. Two birds died within one week of capture, the remainder increased in body mass above capture levels once they had been in captivity for a week (Mean captivity mass = 157g.).

(b) Study aviary

The outdoor aviary had a surface area of 18 m², divided into two equal sized pens. Each pen was totally enclosed with half inch wire mesh, including the base sunk 15 cm below the surface. One half of the pen was covered with corrugated plastic. In each half there were several logs and stones, a large water tray - 50x30x10 cm deep, several smaller water trays and several food trays. In one half there was an artificial mud-flat 1.5x1.0m x5cm deep, containing mud from Skinflats site 4 (section 2.2.1(a)). A garden shed formed half of one side of one pen. It was possible to enter the aviary unnoticed and observe the

birds via a small slit

(c) Harness

Transmitters designed to telemeter heart-rate may be mounted internally (e.g. Duncan 1977) or externally (e.g. Ferns et al 1979). Internal mounts have the advantage that the birds appear unaware of their presence (Duncan 1977), however, they require large batteries which would probably exceed 10% of the body mass of a Redshank, and there are practical difficulties inserting such a large package into a small body cavity. External mounts on the other hand, using safety pin electrodes, are probably highly stressful, disturb the birds because they are not carried continuously, and result in a large quantity of rejected data due to the uninsulated electrodes picking up skin and air potentials (up to 30% rejection - Ferns pers. comm.).

Permanent electrodes were therefore placed subcutaneously and terminated externally in a terminal box, secured on the bird's dorsal surface by a harness around the wing bases - A SNF 102T transmitter (Dynamic Electronics Ltd.) with the battery holder removed to reduce weight and two Duracell 102F batteries spot welded together and soldered to the base of the transmitter, could be plugged into the box prior to each run (Assembled mass = 4.7g (3% of mean body mass)). This system combined the advantages of internal mounting - insulated electrodes, bird acclimatizes to harness, with those of external mounts - small batteries reducing mass.

Electrodes were constructed from a small loop of silver wire, hammered flat to increase surface area, and soldered to a 10cm length of insulated copper wire. The solder was encased in Araldite.

(d) Electrode positioning

A preliminary experiment evaluated three different electrode placements.

- (i) Indifferent electrode 1cm. anterior of the preen gland on the dorsal surface Positive electrode 1cm. anterior of the anterior end of the sternum.
- (ii) Indifferent electrode between the scapulas, positive as above.
- (iii) Indifferent and positive electrodes equidistant, two cm. either side of the sternum, 1cm. anterior of the sternum.

Position (i) combined the largest signal (130 μ V) with the least loss due to interference from E.M G.'s (c. 5-10%), and was subsequently used in all experiments.

(e) Operation procedure

Anaesthetizing Redshank with Pentobarbitol sodium (Nembutal) proved difficult, birds were therefore anaesthetized with Xyaline hydrochloride (Rompun-Bayer U.K. Ltd.). Rompun (200mg./ml.) was diluted in sterile water, one part in five, and injected, at a rate of 0.01ml./12g. (10 x the recommended maximum), intra-muscularly in the upper leg. Birds were left 15 min. in the dark prior to operating.

Birds remained semi-conscious throughout the operation (30 mins.) but were unresponsive to stimulation. No feathers were removed. A small incision, 1cm. long, was made on the bird's dorsal surface, 3cm. anterior of the preen gland, slightly to one side. One electrode was guided, via this incision, subcutaneously posteriorly to a position 1cm. anterior of the preen gland, where it was secured in place by a suture through the epidermis and the loop of the electrode. The second electrode was guided from a similar incision 1cm anterior of the wing base and secured at the interclavicular pit, 1cm anterior of the sternum. All the inserted parts were sterilized in absolute alcohol prior to the operation. Birds were retained indoors, in a dark box, overnight after the operation and were subsequently released back into the aviary (section 2.15(b)) Birds showed no distress during or mass

loss after (see Butler and Woakes 1976) the operation

(f) The relationship between heart-rate and metabolism

The major factors influencing energy expenditure in endotherms are increases in heat loss (e g. decreased ambient temperature, increases in windspeed) and activity. It is probable the relationship between heart-rate and metabolism varies across these conditions of increased energy expenditure (Ferns et al. 1979).

Metabolism was measured by indirect calorimetry (for details see section 2.13(a) and Fig. 9). E.C.G.s were recorded by a direct wire into the terminal box (section 2.15(c)), connected to a stimulus preamplifier and stored on magnetic tape in the first channel of a stereo tape recorder (Revox). A C.R.O. visual display and headphones allowed the signal to be monitored throughout experiments.

Birds were weighed prior to experimentation but were not starved. The mask and E.C.G. lead were attached to the bird, which was then placed into the box in the incubator, where it could move about at will. The temperature was set between -5 and 20°C . The handling procedure took less than five minutes. Birds were left 20-30 mins. to settle. Other than diurnal rhythms, the metabolism after 20-30 mins, did not decrease significantly over the next 17-24 hrs., at a given temperature.

Records of E.C.G. were started approximately 30 min. after the bird was placed into the incubator. Recording continued for approximately 30 minutes after which the ambient temperature was changed. The temperature was allowed to stabilize (c. 40 min.) and then a second 30 min, E.C.G. record was made. This procedure was repeated. Birds normally remained in the box for between four and five hours. Temperature within the box was measured using a Grant temperature recorder. A microphone in the base of the box, connected to the second channel of the tape recorder, recorded the spontaneous activity of the

bird throughout any recording period. Spontaneous activity was preferred to exercising the birds (section 2.13(a)) as this latter technique involves a great deal of unquantifiable stress.

Birds were kept in darkness to avoid stress throughout each experiment. Ambient gas levels, within the incubator, were estimated approximately every hour by disconnecting the mask tube for about a minute and replacing it with an identical length of portex tubing terminating inside the incubator. Ambient CO₂ and O₂ levels did not change significantly in any run.

Previous research has emphasised individual variability in the heart-rate metabolism relationship (Morhardt and Morhardt 1971, Ferns et al. 1979, Woakes and Butler 1983) and even variation within individuals over time (Ferns et al. 1979, Folk and Lund 1976). All heart-rate data collected within the aviary were therefore collected within a two week period for a given individual. Estimates of the relationship between heart-rate and metabolism were made on at least 2 separate days in each individual within one week of collection of data in the aviary.

See section 2.16(b) for leak test of mask.

(g) Costing short duration behaviours

Experimental birds were captured and the assembled radio-transmitter (section 2.15(c)) attached to the terminal box (approx. 2 mins.). The birds were released into the aviary immediately, but the deep water trays were removed because bathing short circuited the batteries, birds could still drink from the small trays (section 2.15(b)). The E.C.G. signal was picked up using a unidirectional dipole aerial attached to a PDF 102R radio receiver. The amplified signal was stored in the first channel of a magnetic tape recorder (Revox). At low temperature signal stability was poor. The signal was therefore continuously monitored with a C.R.O. and intermittently with headphones.

A simultaneous commentary of behaviour was made on the second channel of the tape. Individual observation periods varied between 5 min and 1 hr. Six hours data were collected on each of four individuals, three hours on a fifth and one hour on a sixth. Temperatures on observation days were recorded every half hour using a Grant temperature recorder. Windspeeds within the aviary were always less than 2 m s^{-1} , and were recorded intermittently throughout each observation session.

(2.16) Further metabolism experiments

(a) The effect of windspeed

Three hand-reared Oystercatchers were kept in an outdoor aviary. Metabolism estimates were made at various windspeeds between 0 and 8 m.s^{-1} using an open flow wind tunnel respirometer (see Whitlock 1979 for details of respirometer). No windspeed experiments were performed with Redshank.

(b) Reliability test of mask technique

The collection of respiratory gases via a mask may be criticised because of the stress it causes the bird and because the equilibrium volume may be so small that all the respiratory gases are not collected - especially with a large bird like the Oystercatcher. Increasing the flow rate was not possible because of the narrow gauge tubing. Theoretically, the gas extraction rate was well above the total gas exchange rate - predicted from allometric equations relating tidal volume and respiratory frequency (Schmidt-Nielsen 1975) and increasing flow rate from $0.2 - 2.0 \text{ L.min}^{-1}$ resulted in increased estimates of production only up to 0.8 L.min^{-1} suggesting that below this flow rate some gases were being lost, whilst above it they were not.

It does however remain possible that above a certain flow rate the

efficiency of collection is not enhanced and above $0.8 \text{ L}\cdot\text{min}^{-1}$ the proportion of gas lost remains constant. A more rigorous test was performed by sealing an Oystercatcher wearing a mask in an open flow respiratory chamber, extracting gases simultaneously from both the mask and the chamber and analysing for CO_2 . Any gas leakage would thus show up as elevated ambient levels within the chamber. The bird's metabolism was kept artificially high by tapping the walls of the chamber periodically. No change was recorded in ambient levels over a 45 min. period, suggesting that gas leakage was insignificant.

PART THREE - Model Tests

(2.17) Redshank

(2.17.1) Search strategy

(a) Walking speed

As a walking animal increases its velocity, it must either make paces more rapidly or increase its stride length. Normally animals increase both simultaneously (Clark and McNeil Alexander 1975). Estimates of walking speed in the field made by multiplying observed pacing rates by the mean stride length (Goss Custard and Rothery 1976) assume stride length is constant and possibly underestimate fast speeds, but overestimate slow speeds. Relationships between pacing rate, stride length and walking speed were established by observing walking Redshanks (section 2.15(a)) in an indoor aviary (section 2.15(b)). Pacing rates and stride lengths were measured in the field and the appropriate least squares fitted regression equation was used to predict walking speed.

(i) Field estimates of stride length

Fresh Redshank footprints were located in plots 4 and 5 at Skinflats (section 2.2.1(a)) and plots 1, 5, 6 and 8 at Culross (section 2.2.1(b)). Length was measured from the apex of one print to the apex of the next. Between prints a stick 50 cm long, with a C.S. Area of 25 mm², and a ball of plasticine attached centrally (total weight = 50 g.) was dropped from a height of 30 cm. The depth of penetration was a measure of mud softness.

(b) Search strategy - angularity

Direct estimates of angularity were not possible because unlike other birds where angularity has been measured, e.g. Thrushes (Turdidae Smith 1974) Redshank do not turn in discrete events, but gradually over several paces. Angularity was measured as the angle of deviation of the actual path from an expected direct path at a distance of one metre (see Fig. 10 and Speakman 1983). Fresh footprints were located at Skinflats on three tides in spring, within 2-4 hours of tidal emersion. Angularity in the path was measured from a randomly selected print. Estimates of prey availability (Hydrobia only) (section 2.6) were made 12.5 cm either side of the path (section 2.7) using a 5 x 5 cm quadrat, at 25 cm intervals along the path for 5m. backwards along the path, from the randomly selected print.

On one tide three parallel transects 30 cm apart, and 15m long were marked on the mudflat adjacent to the area where angularities were measured. Estimates of Hydrobia availability were made at 16.6 cm intervals along each transect, using a 5 x 5 cm quadrat, to estimate patchiness in the prey population.

(2.17 2) Diet choice(a) Direct observation

Foraging Redshank were observed in all plots at both sites (section

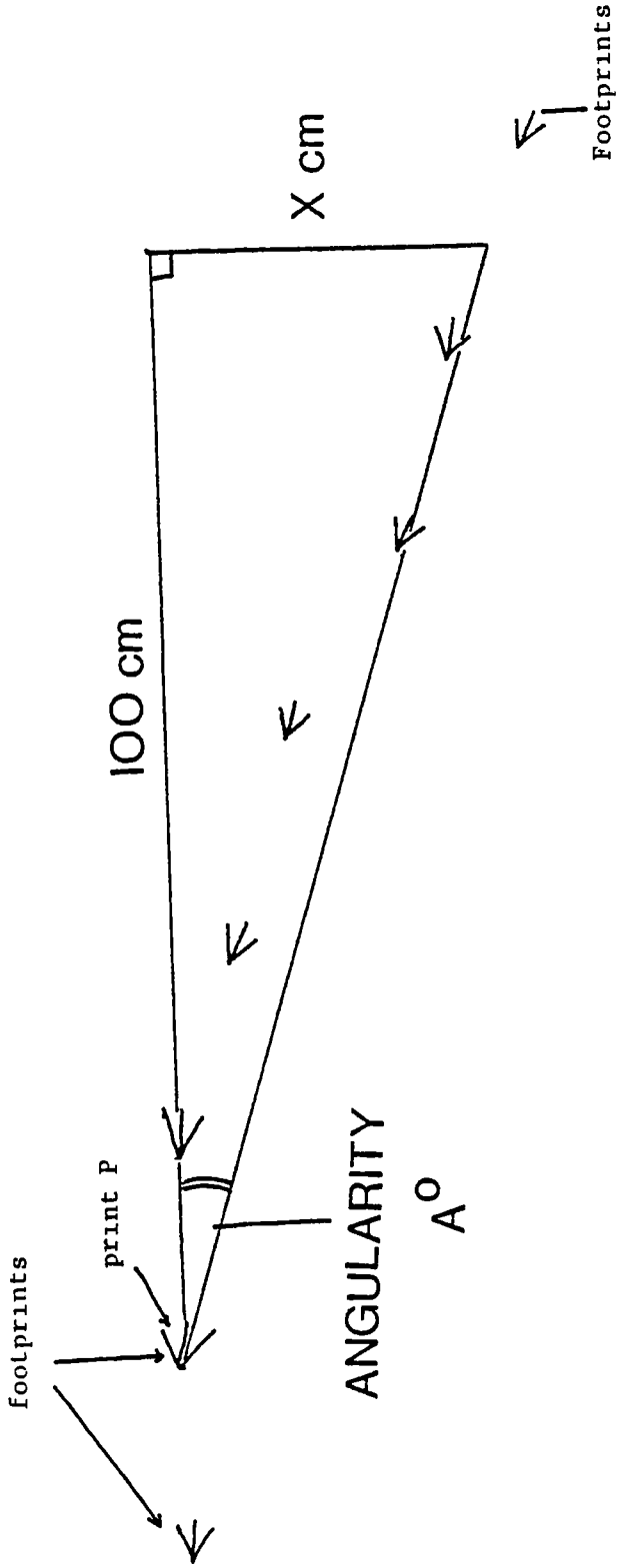

$$\tan A^\circ = X / 100$$

Fig 10 The measurement of angularity in the foraging path of the Redshank The print P was selected at random A metre rule was placed from the apex of print P through the apex of the next print The distance x was measured Angularity (A°) was found using the above formula

2.2), in each study period (section 2.3), for periods of approximately 30s., using a tripod-mounted telescope. In each observation period the number of paces and number of prey items ingested was recorded. After each observation the mode of feeding, distance from the observed individual to the nearest Redshank, distance to the tide edge, shade temperature, windspeed, rain/snowfall intensity and time of day were recorded. Pacing rate was estimated as the number of paces per second.

Prey were allocated to one of nine classes by comparison to the bird's bill and eye. The classes were - small items, Macoma - small 0.25-0.75cm., medium 0.76-1.25cm., and large >1.26cm., Crabs, and Nereis small - 2cm., medium 2.1-4cm., large 4.1-6cm., and very large 6-8cm.

(i) Reliability tests of direct observations

Goss Custard (1969) has demonstrated that inter-observer reliability in evaluating the ingested items in Redshank is high. However, because Redshank do ingest the items it is difficult to independently validate the observations. Observations were made of prey items held in forceps by an assistant seated 100m. away, using the same optical equipment as in the diet choice observations above. All items were held in view for 1 s. Items were selected, at random, from 10 Hydrobia ranging in body length (Appendix 1) from 1.2 - 3.6mm., 23 Macoma ranging in body width from 0.25-1.7cm., and a crab. Occasionally, the forceps were held up empty to represent false pecks. Prey were allocated to one of six classes - nothing, Hydrobia, Macoma - small, medium and large, and crabs.

(ii) Correction for worm stretching

Freshly killed Nereis were held in two pairs of forceps - at the pharynx and terminal segment (Appendix 1). Worms were extended until the body was straight but not taut, and measured, and then stretched until they broke. Worms which broke at the segments which were gripped were discarded. The length at which worms broke was measured.

(b) Collection of pellets

In common with many species, Redshank eject pellets containing the hard indigestible portions of their food. These pellets are roughly oval in shape and measure approximately 10 x 15 x 7 mm. Remains of all the prey ingested can be found in pellets crushed and whole Hydrobia shells, terminal segments of peripods and antennae of Corophium, shell and hinge fragments of Macoma, jaws of Nereis, and crushed fragments of the exoskeleton and the dactyle of the chelae of crabs. Relationships between the size of these fragments and the total body size were established in intact specimens collected to estimate prey density (section 2.5).

Pellets were collected from species-specific roost sites at Skinflats (Fig 5) in Autumn, early Winter and Spring (section 2.3). Regular searches in late Winter revealed no pellets, probably because the roosts were flooded and pellets had been coughed up into water. Pellets were broken up in absolute alcohol and all the identified remains were measured. The most common remains from Corophium were the basipodite of the last peripod and the basi- and protopodites of the antennae. The latter were most common and reliably identified, and used to predict the body length of ingested items

(c) Collections around search paths

Surface Hydrobia were collected from adjacent (within 5cm. - see section 2.7) and remote from (greater than 20cm.) Redshank search paths at Skinflats, on two tides in Spring, at a temperature of 8°C. The size distributions of the two groups were compared.

(2.17.3) Exploitation pattern

As the tide receded from the mudflat (Culross) the distribution of foraging Redshank was recorded by accurately counting foraging groups and locating them by reference to salient features on 1:12,500 scale maps

Total numbers foraging by each method were mapped at half hourly intervals on five days at each site, in each study period (section 2.3). At the end of each half hour observation, the position of the tide edge was marked on the map, shade temperature, windspeed, rain/snowfall and any other notable features were recorded. During high water numbers of birds roosting at each roost, and numbers feeding in adjacent fields were also counted.

Four visits were made at night, one in each study period (section 2.3) to each site, to assess the numbers foraging in darkness.

(2.18) Oystercatcher

(2.18.1) Search strategy

A predictive relationship was obtained between pacing rate (including changes in stride length) and walking speed by direct observation of captive birds in an aviary (Section 2.15(b)). Pacing rates were estimated in the field by counting the number of paces between handling attempts and timing with a stopwatch, or by dictating the behaviour onto a cassette recorder and subsequently timing with a stopwatch.

(2.18.2) Diet choice

Because Oystercatchers only eat the shells of the smallest mussels (Evans 1977), and no small mussels are eaten at Culross (pers. obs.) it was possible to evaluate diet choice by collecting opened shells from the mussel beds (as in Sutherland 1982, Goss Custard et al. 1980, Zwarts and Drent 1981, Ens 1982). Shell collections were made for 20 mins. at each plot (section 2.2 1(c), on two tides in Early and Late Winter (section 2.3) by two collectors. Fresh shells were collected on several criteria - flesh remains (see section 2.10), clean shiny interior with no silting, elastic hinge - by closing and allowing to spring open, and

proximity to Oystercatcher footprints where the substrate was suitable. All the shells collected were probably from the actual or previous tidal exposure to that on which collections were made because tidal cover would lead to silting up of the shells and opened shells in the laboratory become inelastic after a day or so (pers. obs).

Potentially some of the mussels collected may have been opened by other species - Herring gulls, Carrion crows and Curlew have all been observed feeding on mussels at Culross. Observations of these birds suggests this is improbable. Both Herring gulls and Carrion crows open the mussels by breaking the shells, either by hammering them, throwing them or dropping them from a height. The percentage of broken shells in the collections was low (average = 2%) suggesting this source of error was small. Curlew are more abundant on the mussel beds (up to 150 in Autumn). Observations suggest they are feeding mostly on crabs. The small number of mussels that are eaten are small sized and are ingested whole. It is most unlikely that the collected mussels had died of other factors (e.g. extreme cold) and had the flesh removed by scavengers, as all the collected mussels had been detached from the substrate.

The following values were measured on each collected shell: Barnacle coverage, length, width, height, dry weight and dimensions of the muscle scar (Appendix 1).

(a) Reliability test of shell collections

Estimates of size selection using shell collections are probably biased because large shells are more conspicuous than small shells to humans. To evaluate the relative probability of finding different classes an assistant placed freshly opened mussels with the flesh removed, varying from 0.5-6.0 cm. in length (Appendix 1), on the mussel bed (plot 2) (section 2.2), with the shells open, in the same position as those left by foraging Oystercatchers. The number placed out was

unknown to the collector prior to collection. Experimental shells were distinguished from shells already on the site, that had been ingested by Oystercatchers, by a small yellow spot on the reverse of the shell. This did not affect the chances of finding the shell. The collector (myself) searched the area for 20 minutes. Reliability tests were only performed on myself. As there was no significant difference between the shells collected by the second collector and myself at any plot, our abilities were presumed equal and corrections were applied to the pooled data. Differential probabilities of finding different classes across plots were considered most improbable.

(b) Relationship between muscle scar dimensions and adductor muscle mass

Thirty mussels across all sizes and plots in Late Winter (section 2.3) were opened as in section 2.8. The adductor muscle was separated from the remaining flesh and AFDM was determined for both components (section 2.8). The vertical and horizontal dimensions of the muscle scar and shell length (Appendix 1) were measured.

(c) Relationship between shell mass and thickness

Thirty shells measuring 3-7cm. in length (Appendix 1) were dried (section 2.8) and measured in length. Shells were smashed with a hammer and the shell thickness of fragments c. 1 mm² from the dorsal, posterior, and ventral surfaces of each half were measured, using a micrometer.

(2.18.3) Exploitation pattern

(as Redshank) see section 2.17.3.

Chapter threeRESULTSPART ONE - MODEL PARAMETERS(3 1) Prey density - Redshank(3.1.1) Hydrobia ulvae(a) Culross(i) Spatial variation in total density

The lowest densities of Hydrobia occurred at upshore plots adjacent to freshwater outflows (plots 1 and 4) - Fig. 6 - section 2.2.1).

Excluding these plots, there was a significant positive relationship across seasons, between density and tidal height (Fig. 11). The density at upshore sites was almost 4.5x greater than the density at the Mean Low Water Spring (MLWS) level. The density at upshore sites with freshwater runoff averaged only 18% of adjacent sites with no freshwater.

(ii) Temporal variation in total density

The pattern of density change, across seasons, is shown in Fig. 12. Maximum densities occurred in Autumn (mean density across plots = 16709 m⁻²). By Early Winter the mean population had fallen to 1806 m⁻². This decline continued through Late Winter (mean density = 1279 m⁻²) until Spring, when the minimum densities were recorded (mean density = 1073 m⁻²).

(b) Skinflats(i) Spatial variation in total density

The distribution at Skinflats (Tidal Ht = 4.7 - 5.8 m) was much less variable than at Culross. The coefficient of variation of density estimates, across plots, averaged 25% over the four seasons compared with

CULROSS

Relative
density of
Hydrobia
ulvae

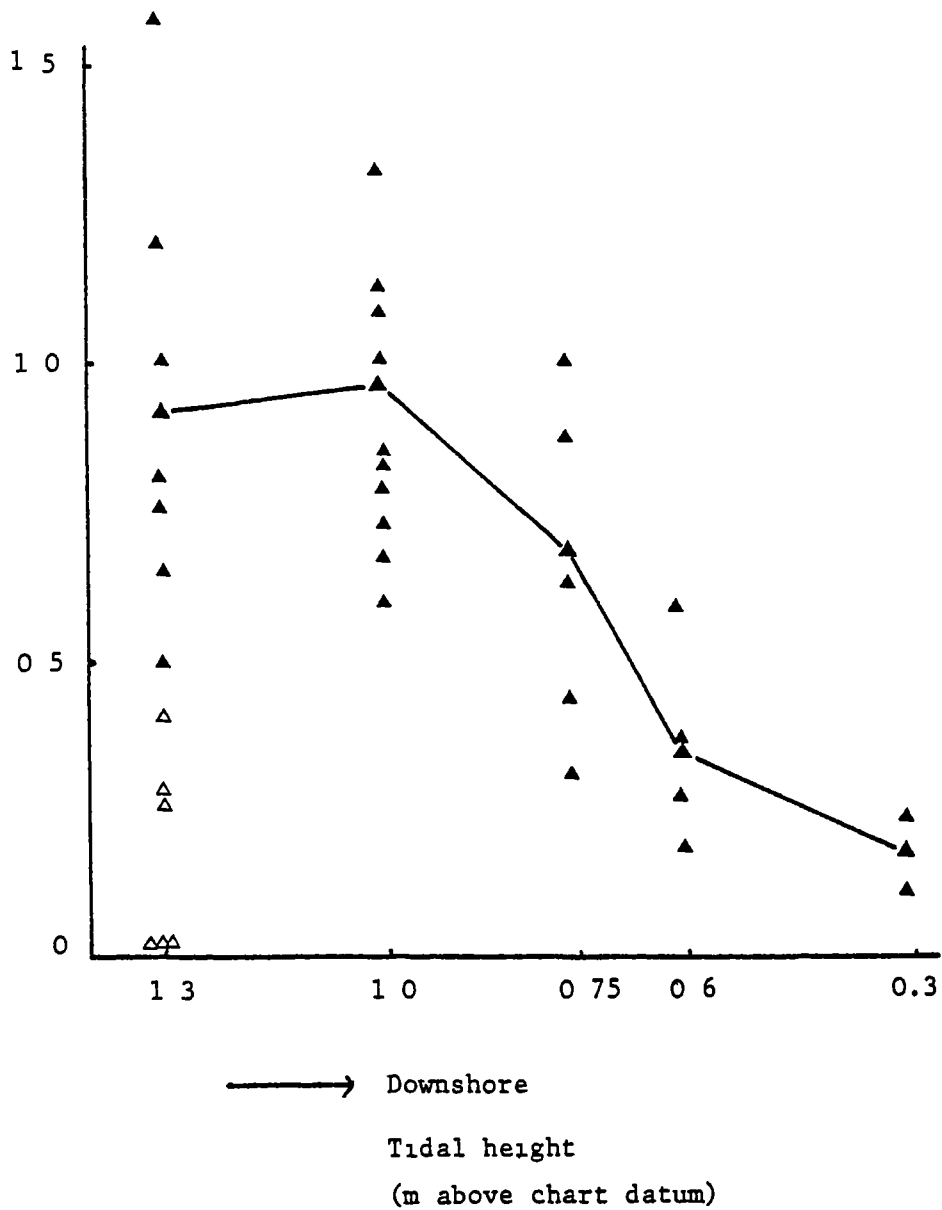

Fig 11 The density of Hydrobia ulvae, relative to the density at plot 7 (see Fig 6) against tidal height at Culross. Data from all seasons combined. Densities are plotted relative to density at plot 7 since large temporal fluctuations across seasons obscured the spatial trend. The line joins the mean relative densities at each tidal height, excluding those plots (1, 3 and 4) with freshwater runoff (open symbols). Plot 7 was selected arbitrarily.

Mean density
of Hydrobia ulvae
($\pm \sigma$)

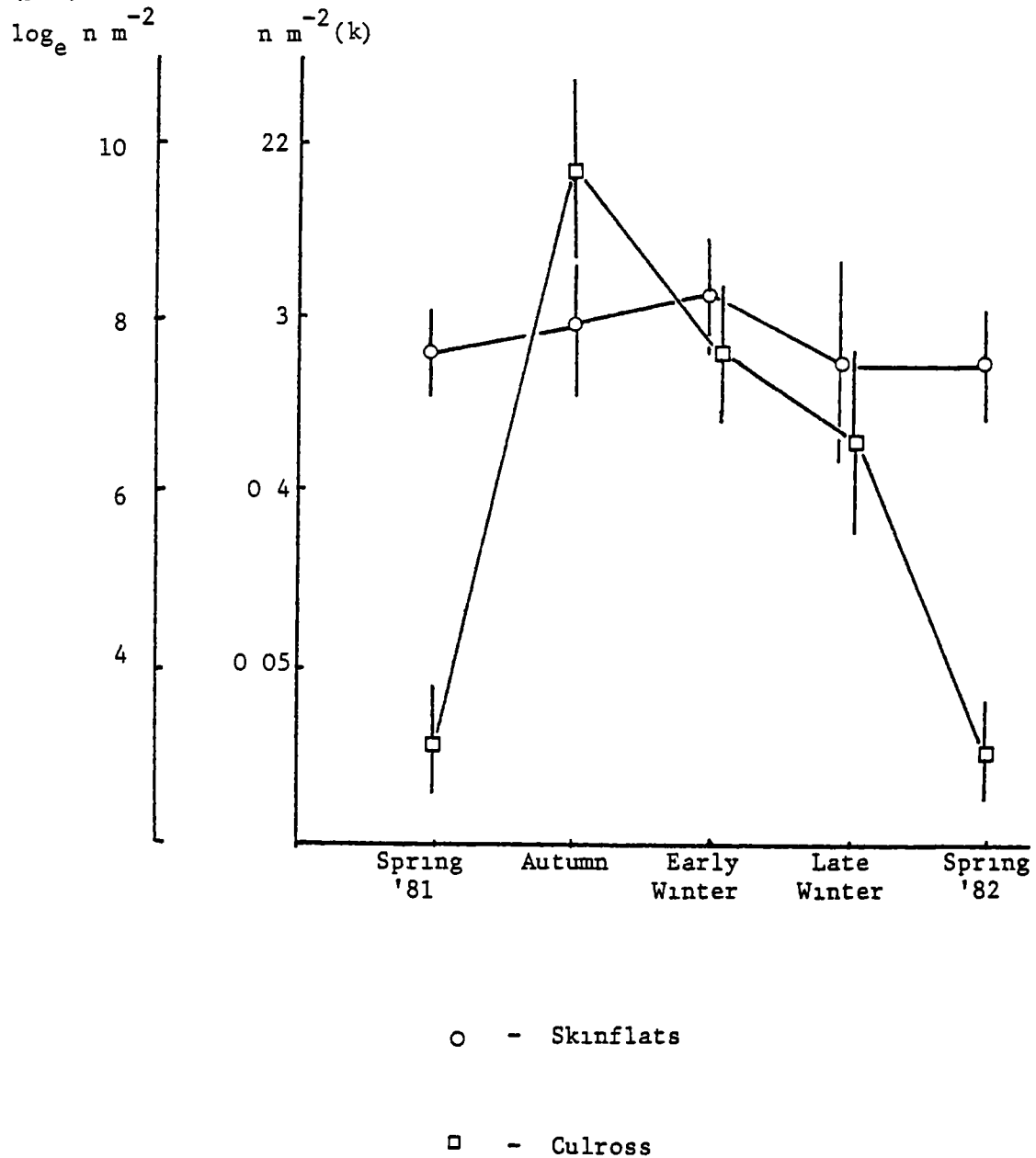

Fig 12 Temporal variation in the density of Hydrobia ulvae at Skinflats and Culross Mean density calculated across all the plots at each site, in each season (See section 2 3 for dates of seasons)

53% at Culross. There was a significant negative relationship, across seasons, between the density and tidal height (Fig. 13). Across all seasons the population density at Skinflats averaged 92% of the population at Culross, although differences in the pattern of temporal variation (below) resulted in a large range (6% - 183%).

(ii) Temporal variation in total density

The pattern of density change across seasons is shown in Fig. 12. Fluctuations in the density at Skinflats were less than at Culross. The maximum densities occurred in Early Winter (mean density across plots = 3260 m^{-2}). Between Early and Late Winter the population declined to an average of 1360 m^{-2} . The density increased between Late Winter and Spring (mean density = 1425 m^{-2}) and continued to increase over the summer (mean Autumn density = 2200 m^{-2}).

(c) Variation in size distributions of Hydrobia

Differences in recruitment, mortality, immigration and emigration across size classes and growth, together result in spatial and temporal changes in the size distribution of the prey. The mean prey size is a crude index of the size distribution. Across all plots, from both sites (section 2.2.1), and seasons, there was a significant curvilinear inverse relationship between the mean size of Hydrobia in a given plot and density (Fig. 14) ($r = -0.537$, $p < 01$, $n = 41$).

(3.1.2) Macoma balthica

(a) Culross

(i) Spatial variation in total density

The spatial distribution of Macoma at Culross was similar to that of Hydrobia (section 3.1.1.a(i)). Excluding plots with freshwater inflow (plots 1 and 4 - Fig. 6) there was a significant positive relationship between tidal height and density (Fig 15). The density at sites with

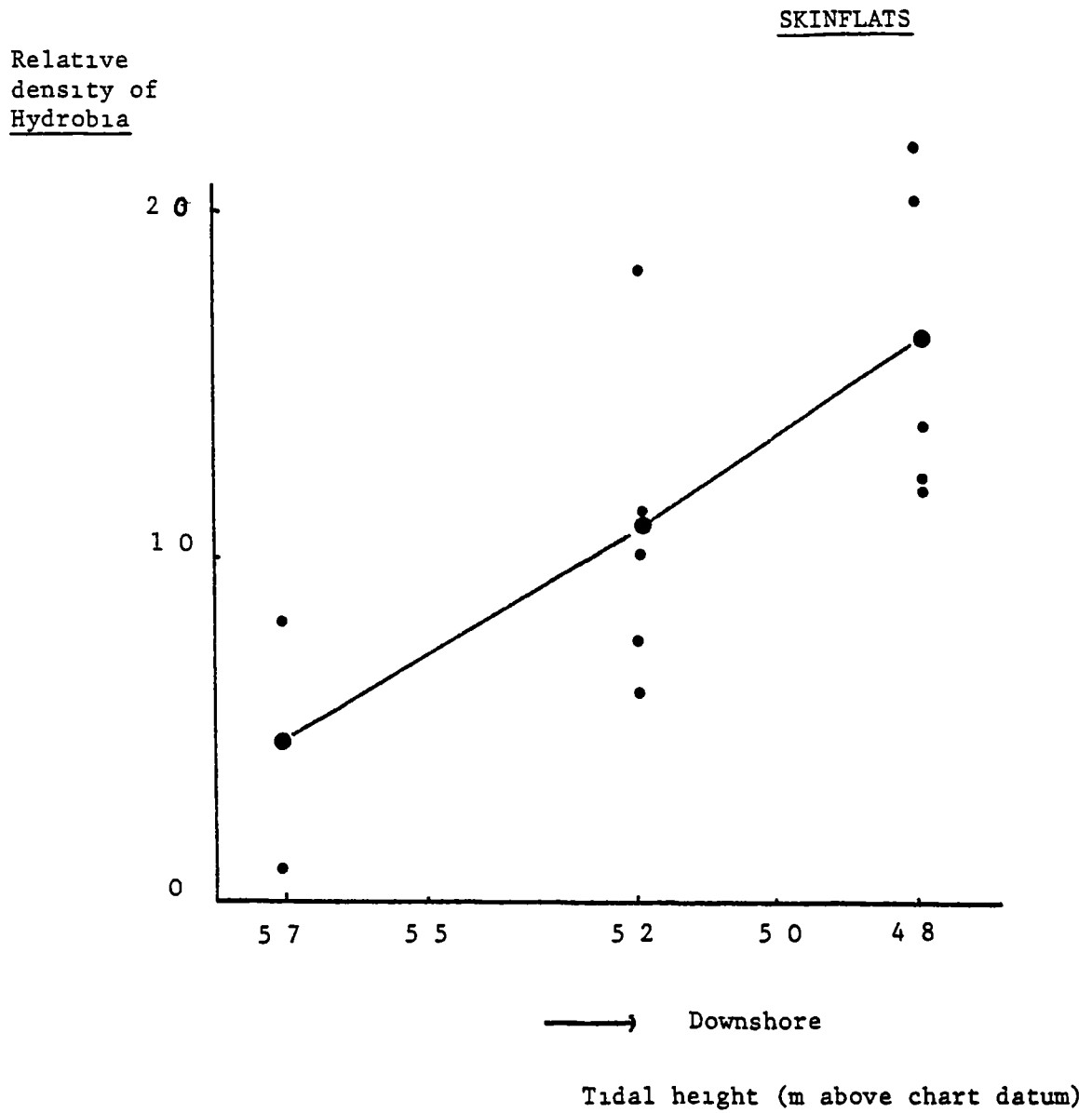

Fig 13 The density of Hydrobia ulvae, relative to the density at plot 4 (see Fig 5) against tidal height, at Skinflats. Densities are plotted relative to plot 4 since large temporal fluctuations in density, across seasons, obscured the spatial trend. The line joins the mean relative densities at each tidal height. Plot 4 was selected arbitrarily.

Mean shell length
(mm)

Hydrobia ulvae

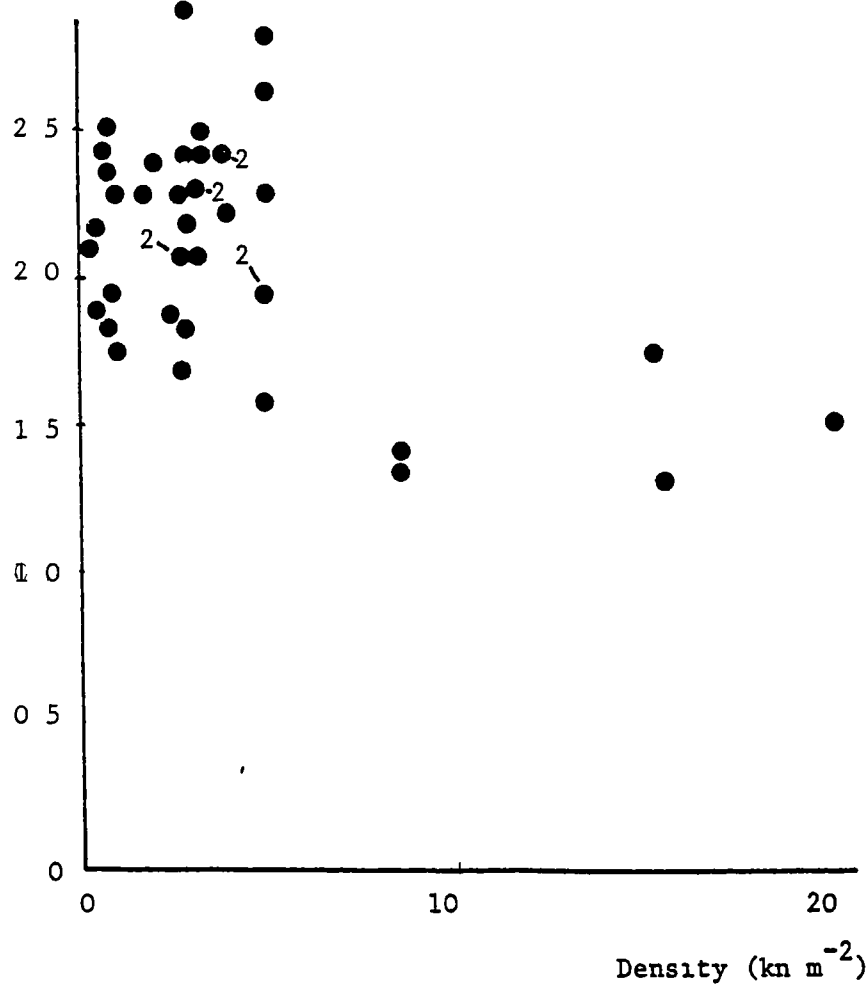

Fig 14 Relationship between mean shell length and density in Hydrobia ulvae Each point represents data from an individual plot Data from both sites and seasons pooled.

$$\log_e y = 0.899 - 0.016 x$$

$$\begin{aligned} n &= 41 \\ r^2 &= 28.9 \\ F &= 15.9 \\ p &< 0.1 \end{aligned}$$

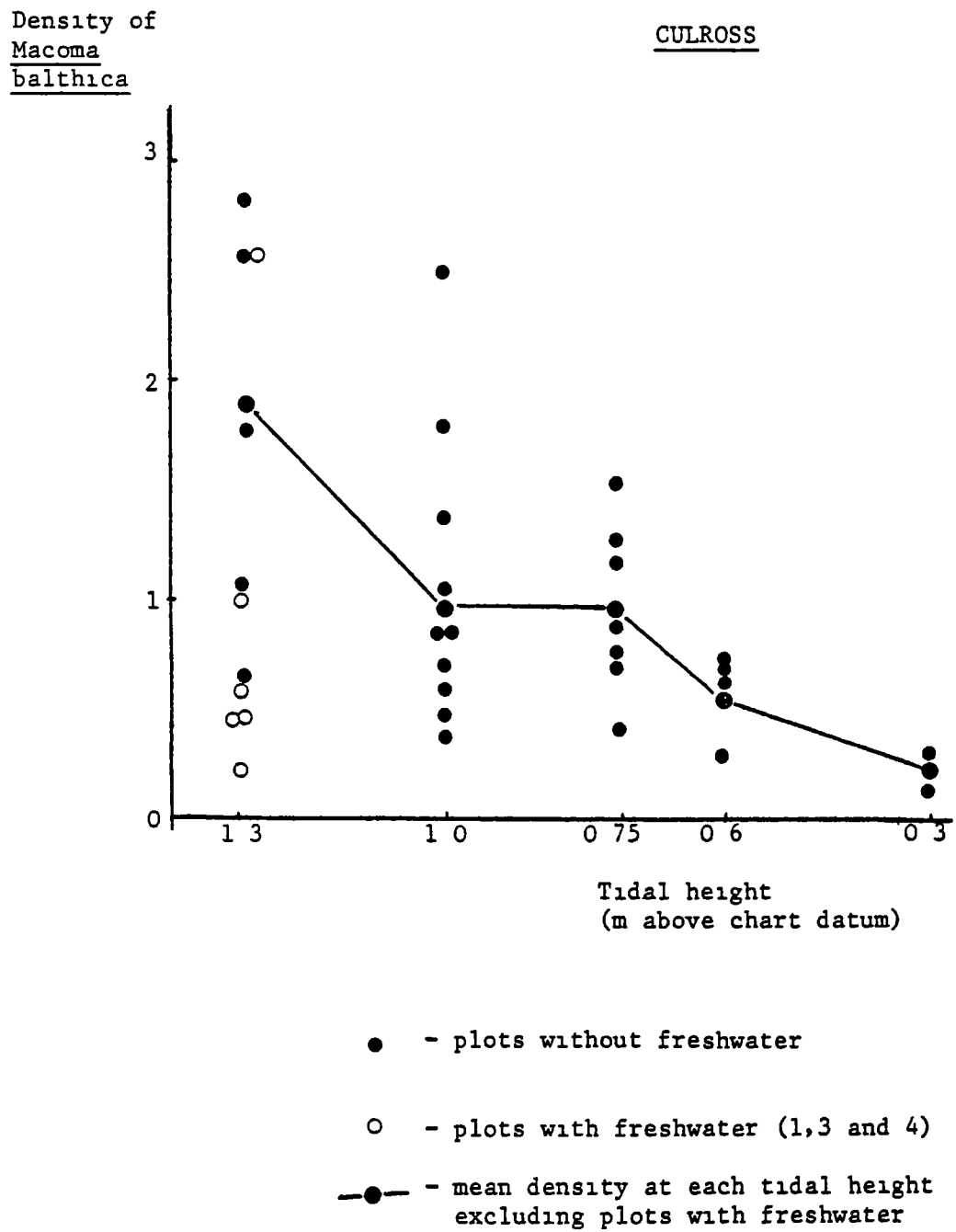

Fig 15 Spatial variation in the density of Macoma balthica at Culross

freshwater inflow was generally lower than adjacent sites with no freshwater, although the difference was not significant because a large population of very small Macoma was recorded at one plot (plot 1) in Early Winter (see below).

(ii) Temporal variation in density

Individual Macoma were allocated to one of four size classes - < 0.25 mm, 0.26-0.75 mm, 0.76-1.25 mm and >1.26 mm body width (Appendix 1). The change in mean density across all plots, with season for each of these classes, is shown in Fig. 16. Between Autumn and Early Winter the mean density of the smallest class increased by 2.65x, from 285 m⁻² to 755 m⁻². Increases were recorded in most plots, but decreases occurred in plots 8 and 9 (Fig. 6). The mean density of the smallest class declined from the peak in Early Winter to 270 m⁻² in late winter and a minimum of 146 m⁻² in Spring.

Mean densities of larger Macoma were less variable across seasons than the densities of the smallest class. The standard deviations of the mean densities, across seasons, were 71.8 (0.26-0.75 mm), 26.57 (0.76-1.25 mm) and 3.65 (>1.26 mm) compared with 267.8 for the smallest class.

The pattern of variability was also different. The three large classes had maximum densities either in Spring (0.76-1.25, and >1.26 mm classes) or Autumn (0.26-0.75 mm.) when the smallest class density was at a minimum and minimum densities in Early/Late Winter when the smallest class was at a maximum.

As fluctuations in the smallest class were greatest, the mean total density was greatest in Early Winter (mean = 1385 m⁻²) and lowest in Spring (mean = 773 m⁻²).

Mean density of
Macoma balthica
 $n\ m^{-2}$ (k)

SKINFLATS

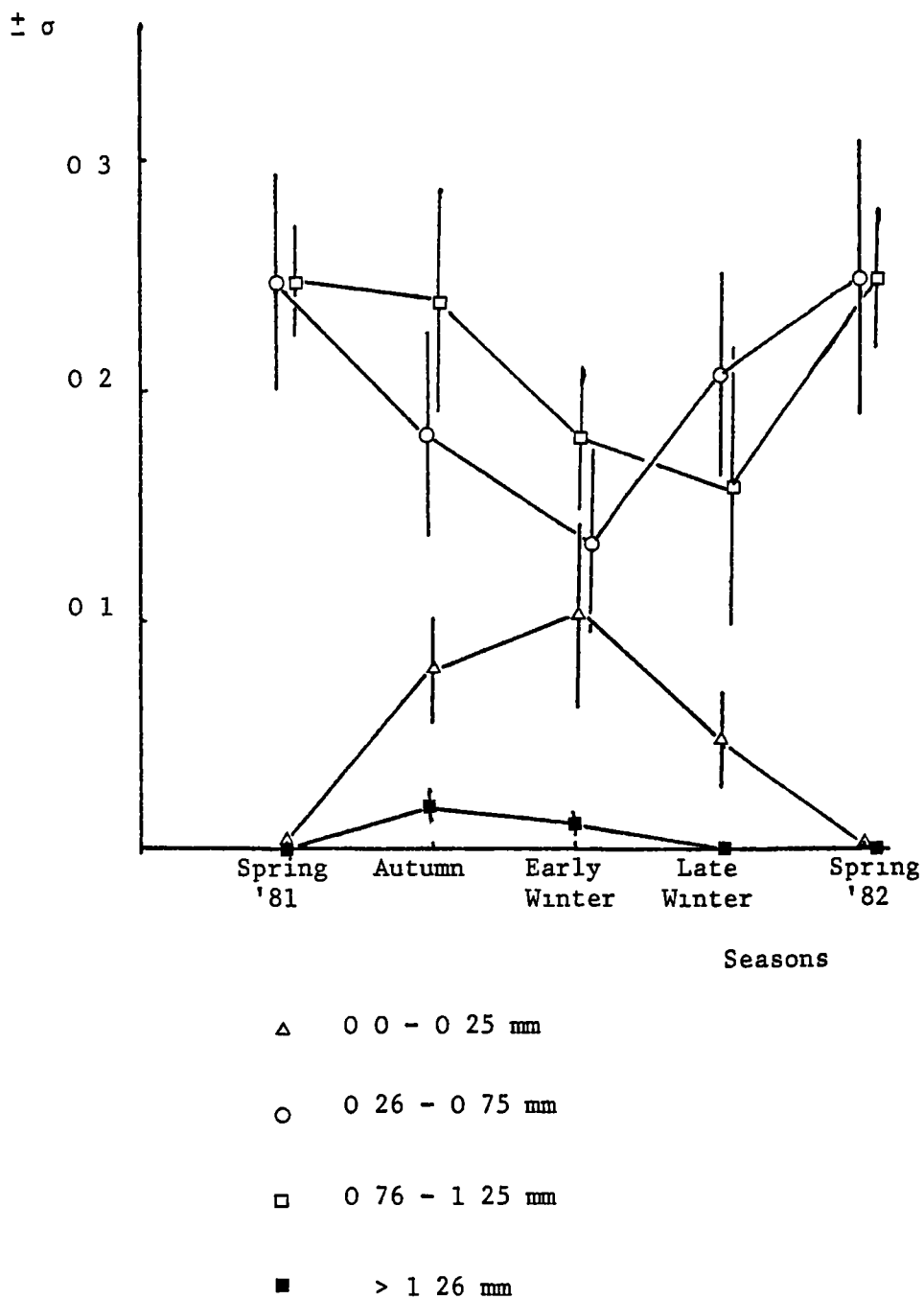
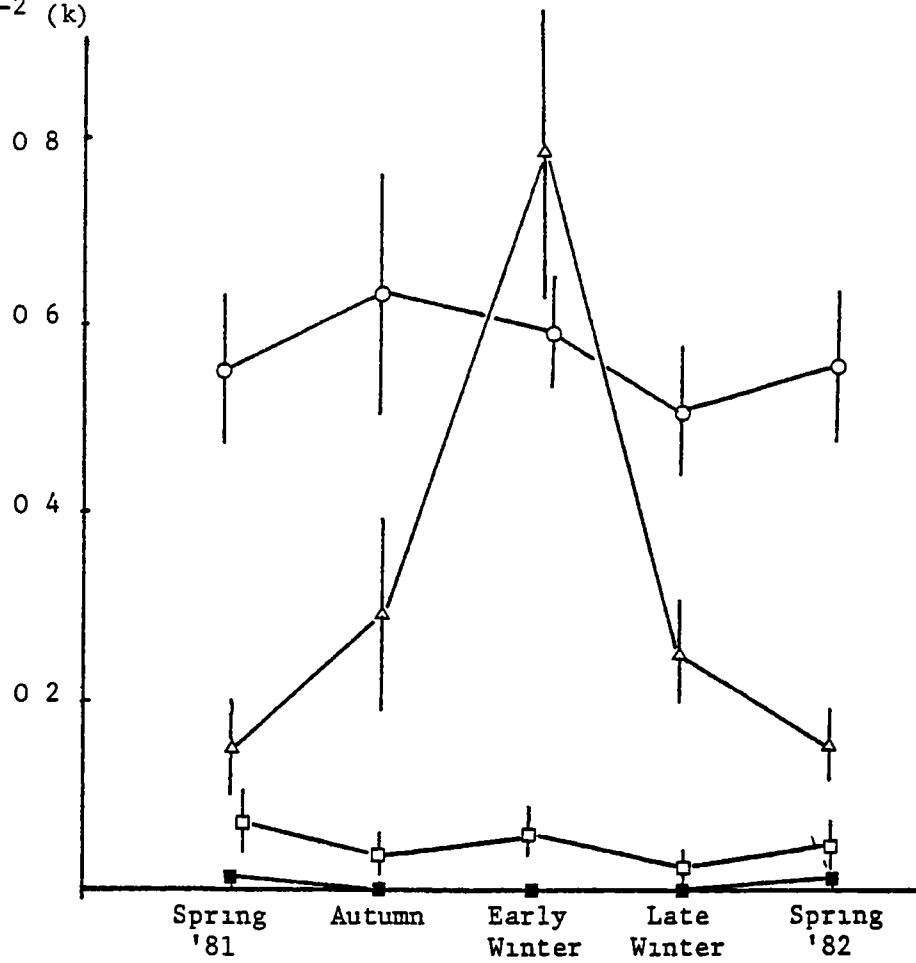

Fig 17 Temporal variation in the density of four size classes of *Macoma balthica*, at Skinflats Mean density calculated across all plots in each season (see section 2.3 for dates of seasons)

Mean density of
Macoma balthica

CULROSS

($\pm \sigma$)
n m⁻² (k)



Δ 0.0 - 0.25 mm

○ 0.26 - 0.75 mm

□ 0.76 - 1.25 mm

■ > 1.26 mm

Fig 16

Temporal variation in the density of four size classes of Macoma balthica, at Culross. Mean density calculated across all plots in each season (see section 2.3 for dates of seasons)

(b) Skinflats(i) Spatial variations in density

Density at Skinflats was independent of tidal height ($r = 0.13$, $p > .05$), and across all plots and seasons averaged 50.9% of the mean density at Culross (above).

(ii) Temporal variation in density

Changes in mean density, across all plots, of the four size classes (3.1.2.a(ii)), are shown in Fig. 17. The pattern was similar to that at Culross (above) - with the smallest class reaching a maximum in Early Winter, and minimum in Spring, whilst larger classes had maximum densities in Spring or Autumn and low/declining densities throughout the Winter.

Although on average the density at Skinflats was only approximately half that at Culross, the difference varied across size classes. The mean densities of the smallest two classes (<0.25 and 0.26-0.75 mm) at Skinflats, were 12 and 34% respectively of the densities at Culross, whilst the third class (0.76-1.25 mm) was 4.7x more abundant at Skinflats. (It was not possible to compare densities of the largest class as none were found in Autumn, Early and Late Winter samples from Culross, and in Spring samples from Skinflats.)

(3.1.3) Corophium volutator(a) Culross

The occurrence of Corophium at Culross was extremely sporadic. It was occasionally recorded at upshore plots adjacent to freshwater outflows - plots 1, 3 and 4 (Fig. 6).

(b) Skinflats(i) Spatial variation in density

Corophium density was not significantly related with tidal height ($r = 0.24$, $p > .05$).

Mean density of
Macoma balthica
 $n\ m^{-2}$ (k)

SKINFLATS

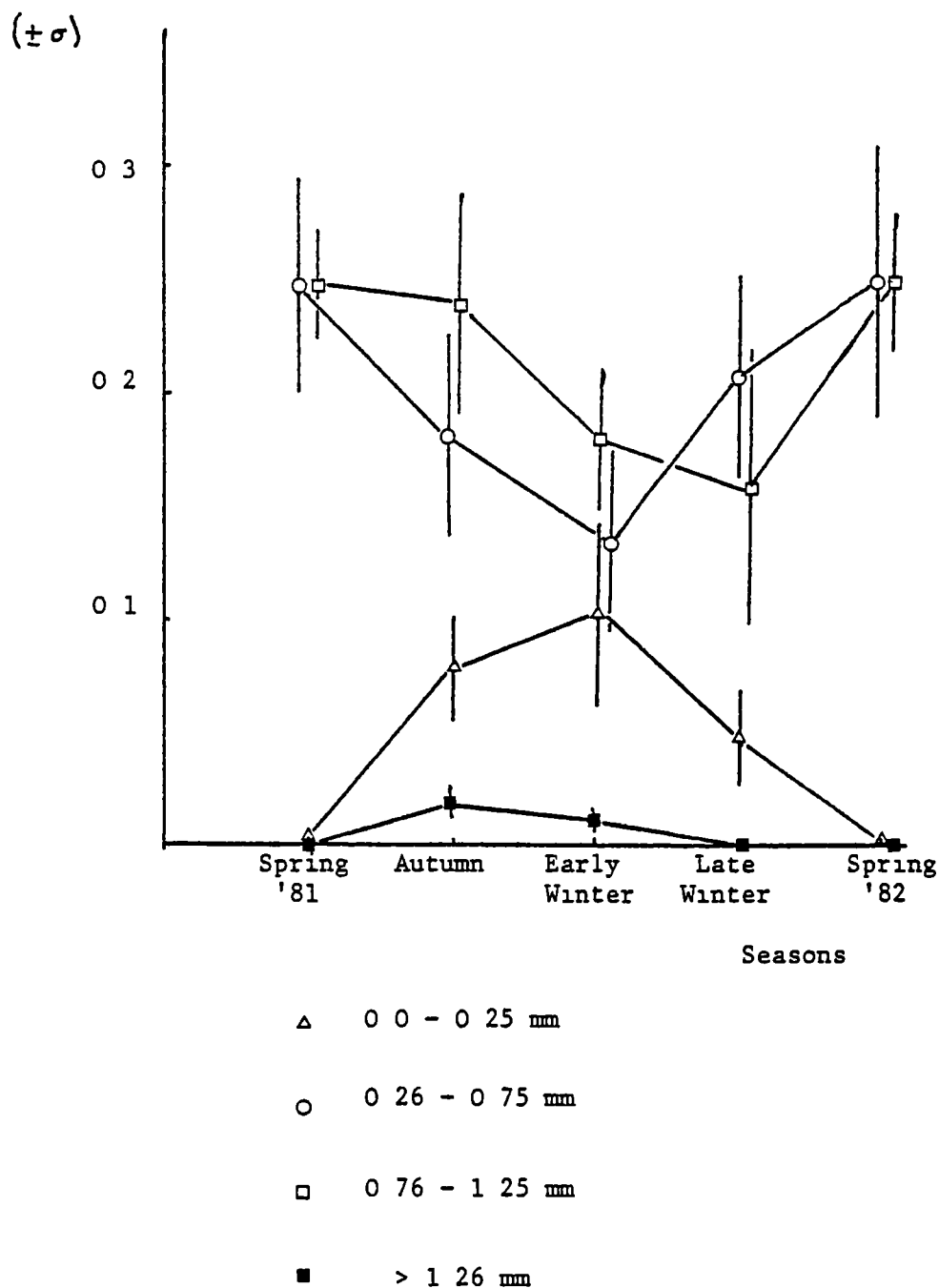

Fig 17 Temporal variation in the density of four size classes of Macoma balthica, at Skinflats Mean density calculated across all plots in each season (see section 2.3 for dates of seasons).

Mean density of
Corophium volutator

($\pm \sigma$)
 $n\ m^{-2}$ (k)

SKINFLATS

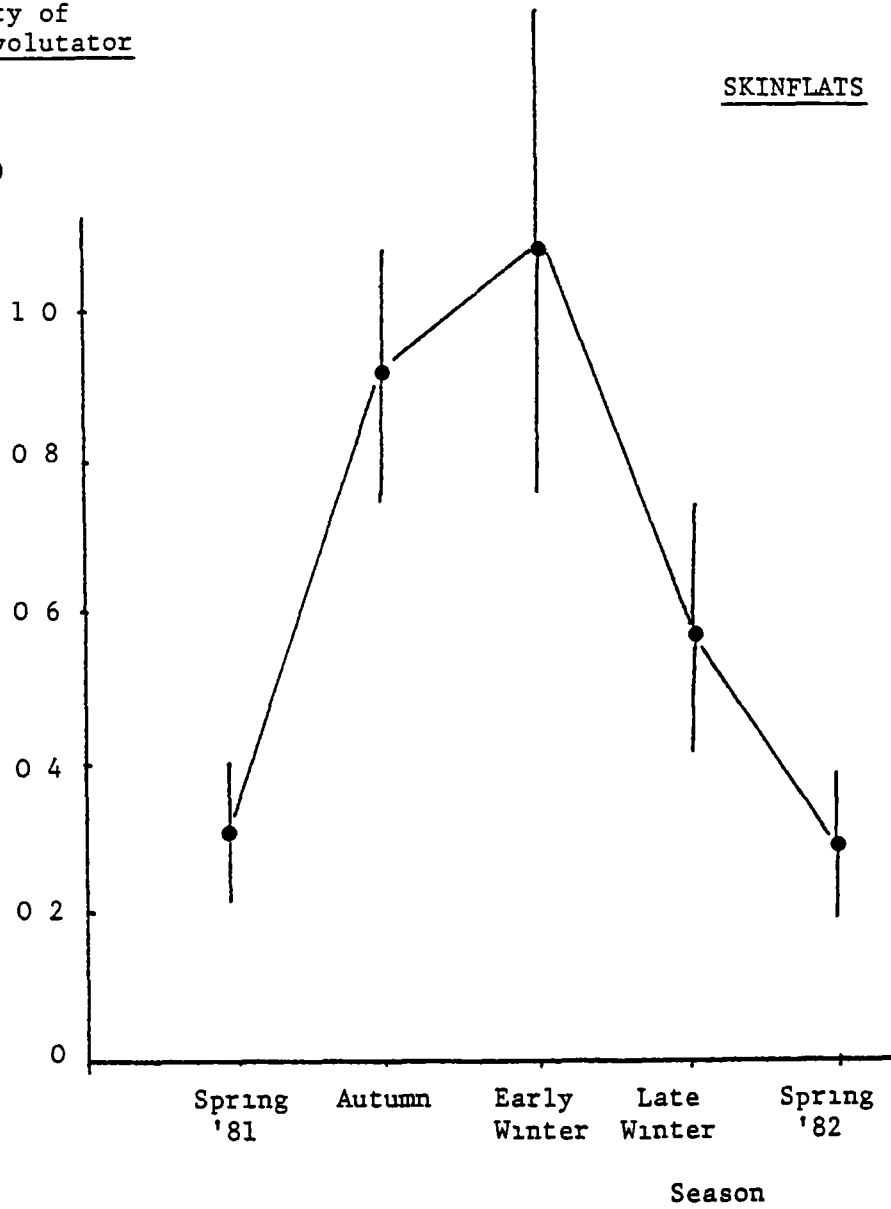

Fig 18 Temporal variation in the density of Corophium volutator, at Skinflats Mean density calculated across all plots in each season (see section 2 3 for dates of seasons)

(ii) Temporal variation in density

Changes in mean total density across all sites are shown in Fig. 18. Although the errors were large, reflecting variability between plots, the pattern of change was consistent across sites. Between Autumn and Early Winter, densities increased from an average 880 m^{-2} to 1120 m^{-2} . From this peak, density declined throughout the Winter (Late Winter mean density = 580 m^{-2}) to a minimum in Spring (320 m^{-2}).

(c) Variation in the size distribution of *Corophium*

The mean size of *Corophium* in a given plot was inversely related with the *Corophium* density (Fig. 19) ($r = -0.564$, $p < .01$, $n = 19$).

3.1.4 Polychaetes(a) Culross (*Nephtys hombergii*)(i) Spatial variation in density

Nephtys density was significantly inversely related with tidal height, across all seasons ($r = 0.40$, $p < .05$) (Fig. 20). Densities at MLWS were approximately 50% greater than those at upshore plots (plots 1-4, Fig. 6).

(ii) Temporal variation in density

Individual *Nephtys* were allocated to one of four body length classes (0-19 mm, 19-35 mm, 35-51 mm and 51-68 mm). These classes correspond to size classes estimated in the field (section 2.8.3), corrected for stretching (section 3.12(b)). Variations in the mean density, across plots, of each class with season are shown in Fig. 21.

The mean density of the smallest class was greatest in Early Winter (30 m^{-2}) and lowest in Spring (mean = 13 m^{-2}). The mean density of the second smallest class (19-35 mm) was almost constant throughout the year and averaged 31 m^{-2} ($\sigma = 3.64$) across seasons, whilst the density of the second largest class was highly variable and had maxima in both

Mean body length
(mm)

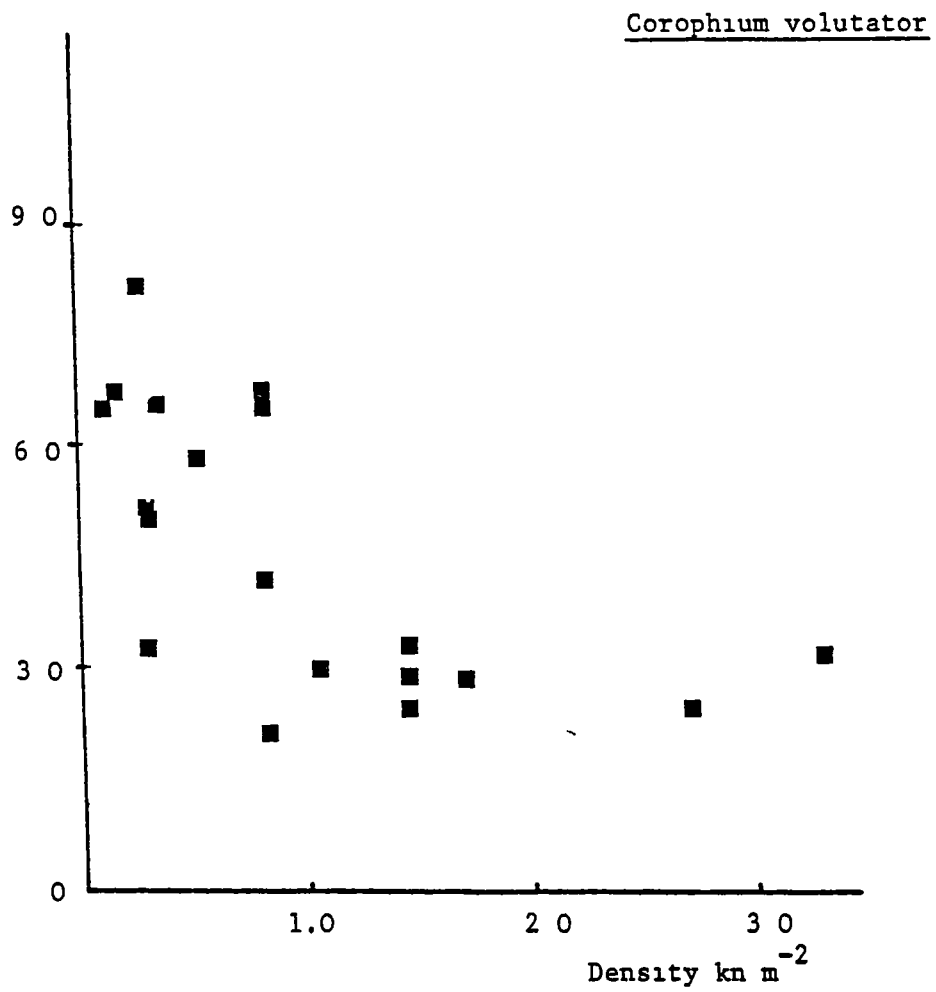

Fig 19 Relationship between mean body length and density in Corophium volutator. Each point represents data from an individual plot. Data pooled across seasons.

$$\log_e y = 1.33 - 0.167 \log_e x$$

$$n = 19$$

$$r^2 = 31.9$$

$$F = 8.11$$

$$p < 0.05$$

Density of
Nephtys hombergii
 $n\ m^{-2}$ (k)

CULROSS

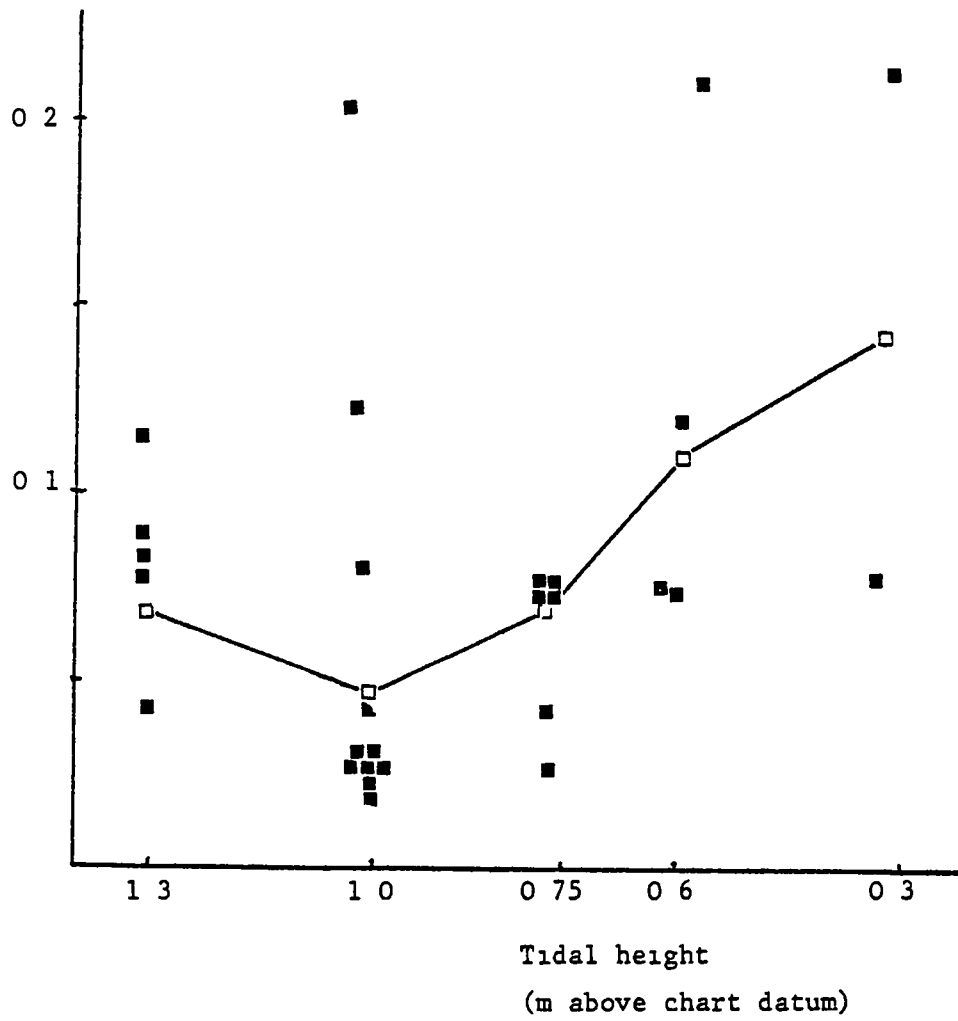

Fig 20 The density of Nephtys hombergii against tidal height, at Culross. Data combined across all seasons. The line joins the mean densities at each tidal height (open symbols)

Mean density of
Nephtys hombergii
 $n\ m^{-2}$

CULROSS

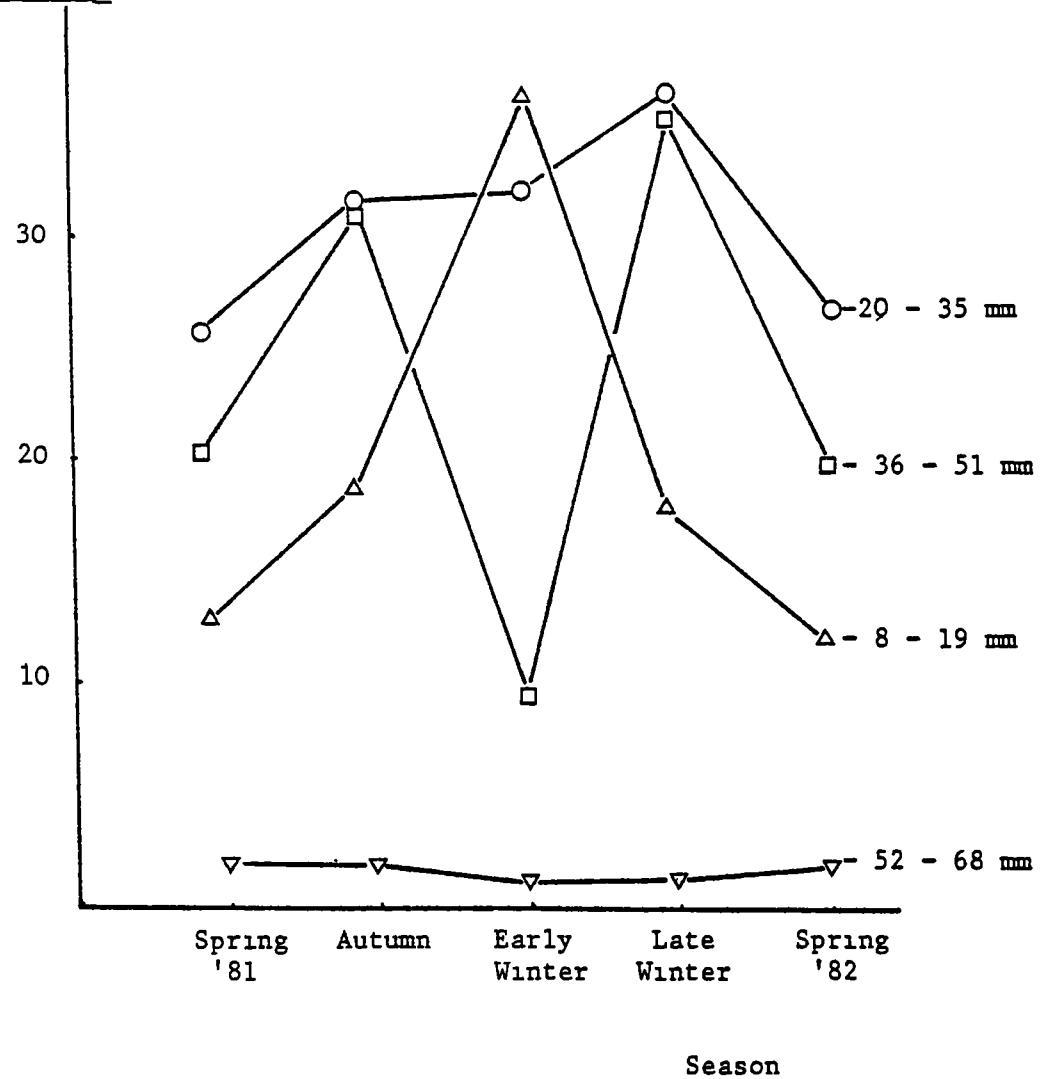

Fig 21 Temporal variation in the density of four size classes of Nephtys hombergii, at Culross Mean density calculated across all plots in each season Standard deviations are not shown to avoid confusion The size classes represent classes observed in the field, corrected for stretching during handling by Redshank

Autumn and Late Winter. The largest class was least abundant (\bar{x} across seasons = 5.1 m^{-2}) and had greatest mean densities in Spring and Autumn. Contrasting fluctuations across classes resulted in an almost constant total density across seasons (mean = 97 m^{-2} ($\sigma = 7$)).

(b) Skinflats Nereis diversicolor

(i) Spatial variation in density

On average, across both plots and seasons, the density of Nereis at Skinflats was 1.83x greater than the density of Nephtys at Culross. Densities were independent of tidal height, over the range considered (4.7 - 5.8 m) ($r = -0.114$, $p < .05$).

(ii) Temporal variation in density

Individual Nereis were allocated to the same body length classes used for Nephtys (3.1.4.a). Temporal variations in the mean density, across plots, of each of these classes are shown in Fig. 22. The pattern of change, across seasons, was similar in all classes. The greatest densities occurred in Spring and Autumn, and the lowest densities occurred in Winter. In total the Winter densities were approximately half the density in Autumn (Autumn mean density = 220.5 m^{-2} , Early Winter = 97 m^{-2} , and Late Winter = 119.8 m^{-2}).

(3.1.5) Oligocheates

(a) Culross

Oligocheates (mostly Tubificoides benedictii) were encountered infrequently during the first season's field work at Culross (1980/81). The population increased from approximately $140-170 \text{ m}^{-2}$ in August 1981 to an average of 2386.7 m^{-2} (mean across plots) in Spring 1982.

(b) Skinflats

Oligocheates were most abundant at Skinflats in August 1981 (mean across plots = 780 m^{-2}). In all the other sample seasons, the

Mean density of
Nereis diversicolor
 $n\ m^{-2}$

SKINFLATS

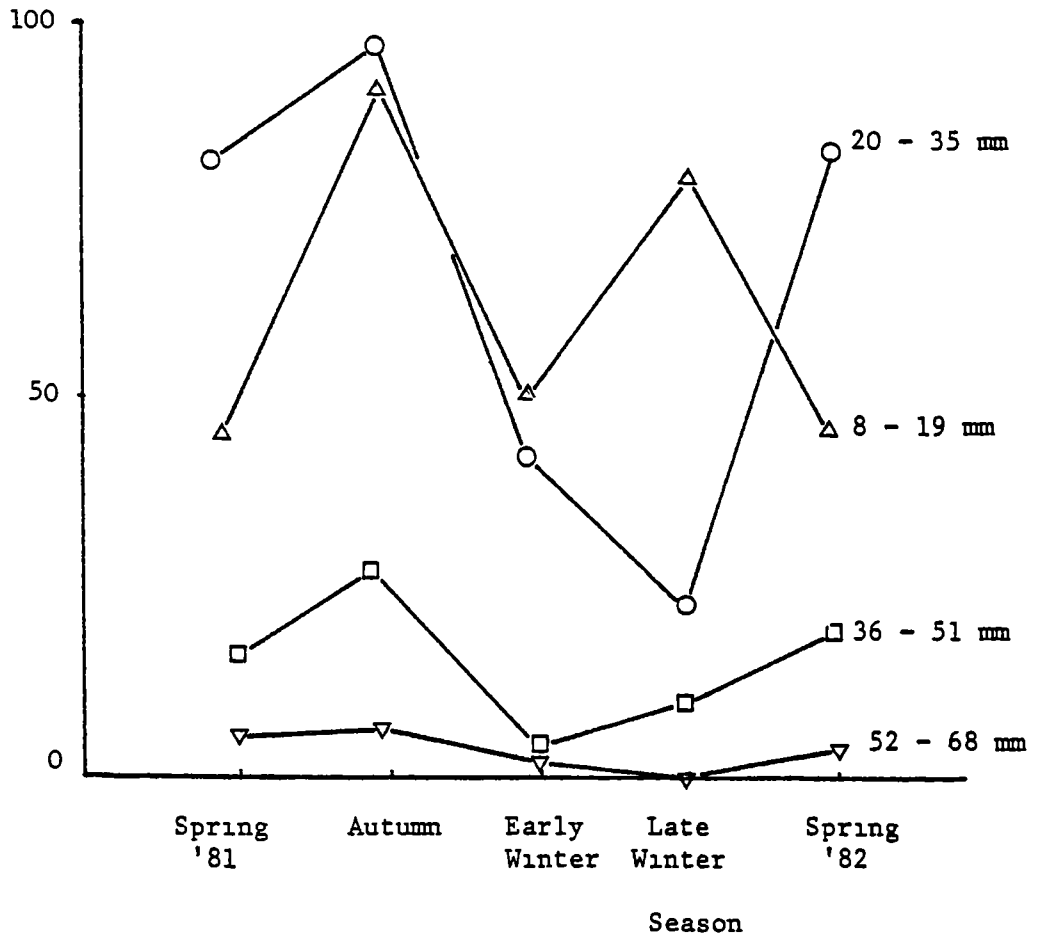

Fig 22 Temporal variation in the density of four size classes of Nereis diversicolor, at Skinflats Mean density calculated across all plots in each season Standard deviations are not shown to avoid confusion The size classes represent classes observed in the field, corrected for stretching during handling by Redshank

densities were less than 70 m^{-2}

(3 2) Prey density - Oystercatcher

(3.2.1) Mytilus edulis (mussel)

The density of mussels, in mussel clumps, averaged across plots on each mussel bed (Fig 7), was not significantly different between beds (mean density on upper bed = 1564 m^{-2} ($\sigma = 395$), mean density on lower bed = 1490 m^{-2} ($\sigma = 151$), $t = 0.46$, $p = 0.66$).

The percentage of the substrate covered with mussels, averaged across plots on each bed, was significantly different between beds (mean cover on upper bed = 63.5% ($\sigma = 15\%$), mean cover on lower bed = 92.8% ($\sigma = 10.1$), $t = 3.42$, $p < .05$ - on Arcsin converted percentages).

The estimated total density (= density in clumps x percentage cover) was not significantly different between the beds (mean for upper bed = 975 m^{-2} ($\sigma = 43.8$), mean for lower bed = 1383 m^{-2} ($\sigma = 203$), $t = 1.96$, $p = 0.054$).

Individual mussels were allocated to 0.5 cm shell length classes (Appendix 1). The size/density distribution averaged across all plots for each mussel bed is shown in Fig. 23. In all except the first (0 - 0.5 cm) and fourth (1.51 - 2.0 cm) classes the mean density was greater on the lower bed. Mean densities were significantly greater at the .05 level for the 8th (3.51 - 4.0 cm), 10th (4.51 - 5.0 cm) and 12th (5.51 - 6.0 cm) classes and significant at the .001 level for the four largest classes.

Mean densities on the lower bed, relative to the upper bed, for each class are shown in Fig. 24. Relative density increased with increasing mussel length. Mussels between 0 and 35 mm in length were on average 0.04x more abundant on the lower bed ($\sigma = .13\%$). Mussels between 36 and

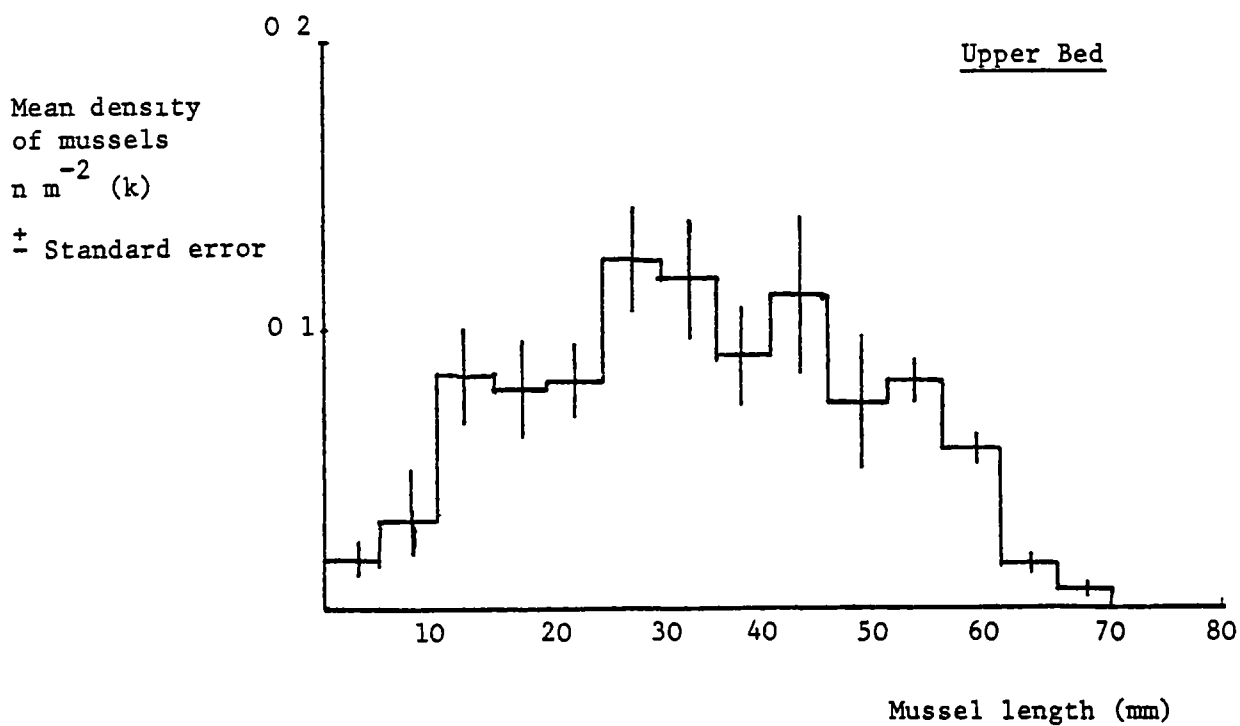
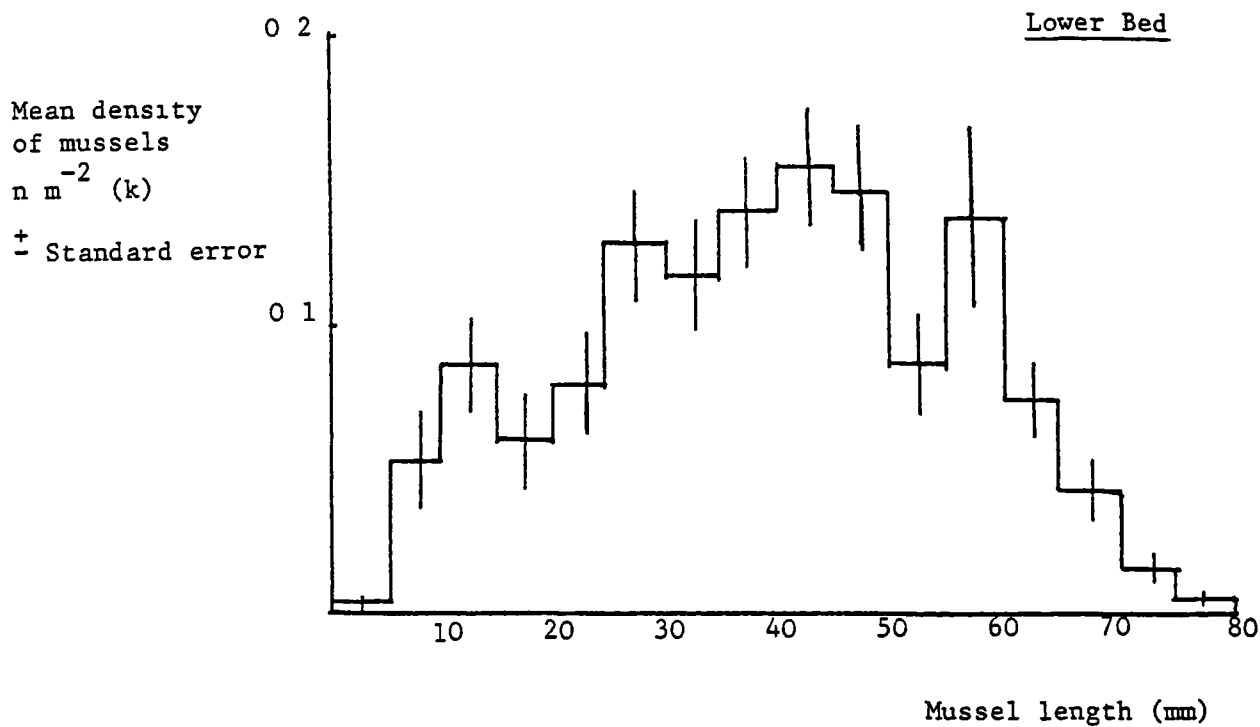

Fig 23 Mean density* of 5 mm mussel length classes on the upper and lower beds at Culross Mean calculated across all plots and seasons, lower bed $n = 10$, upper bed $n = 10$

* Density = Density in clumps x percentage cover

Relative density of class

$\frac{\text{lower bed}}{\text{upper bed}}$

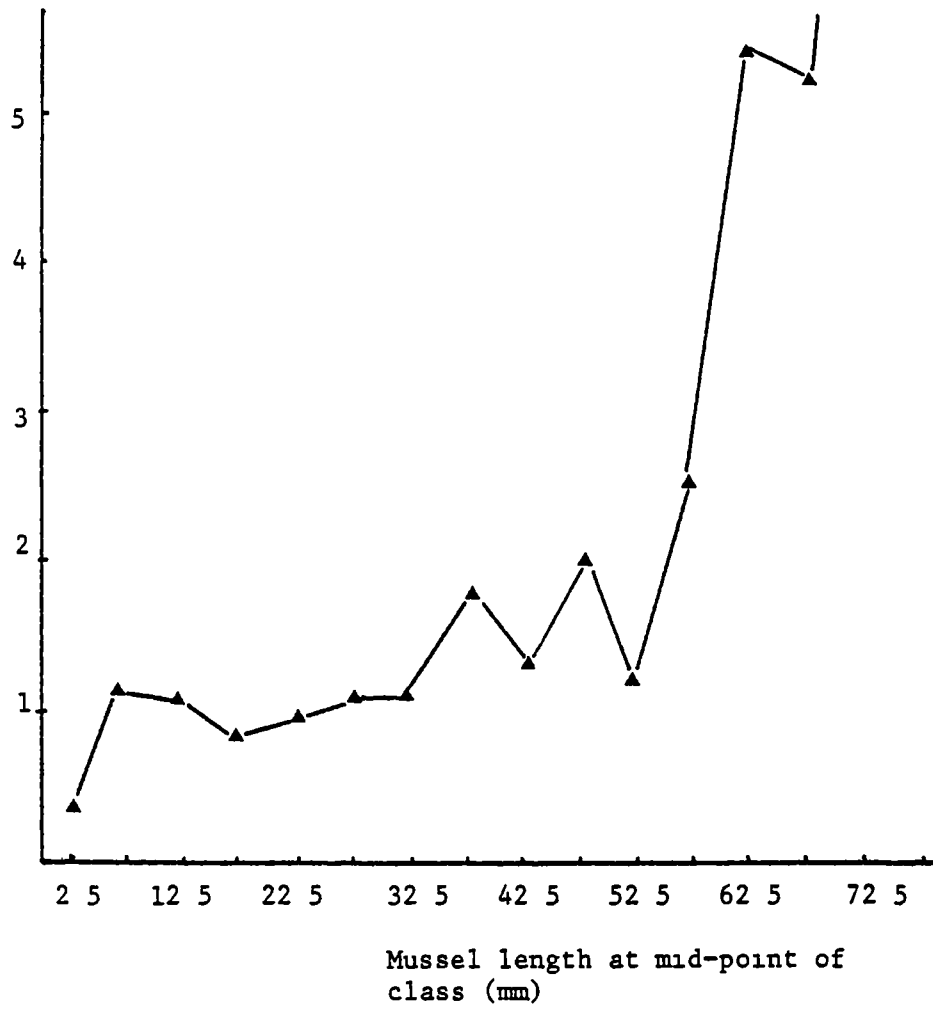

Fig 24 Relative densities of 5 mm mussel length classes between upper and lower beds

60mm. were on average 0.83x more abundant on the lower bed ($\sigma = 0.59$) and mussels between 61 and 70 mm in length were on average 5.3x more abundant on the lower bed. No mussels greater than 70 mm long were recorded on the upper bed. The maximum length recorded on the lower bed was 79 mm

(3.3) Prey energy content

(3.3 1) Hydrobia ulvae

(a) Ash-free dry mass (AFDM)

Ash free dry mass for Hydrobia of equal shell lengths (Appendix 1) was not significantly different between animals from Culross and Skinflats in any season. Data across the two sites were pooled. In all seasons there was a positive curvilinear relationship between AFDM and shell length (Table 3). The regression equations were interpolated to predict the AFDM of 1, 1.5, 2, 2.5 and 3.0 mm shell length animals in each season (Fig. 25).

In Hydrobia greater than 2 mm the maximum AFDM occurred in Autumn. The percentage decrease in AFDM between Autumn and Early Winter increased with increasing size above 2 mm (20% in 3mm. animals 8.5% in 2mm.). Hydrobia less than 2 mm increased in AFDM between Autumn and Early Winter.

Between Early and Late Winter the AFDM of all sizes decreased. Relative decreases were inversely related to length. Across all five sizes the AFDM in Late Winter averaged 37.2% ($\sigma = 5.7\%$) of the AFDM in Autumn. AFDM recovered between Late Winter and Spring in all sizes. Relative increases were directly related to length.

(b) Ash content

Dry ash mass (DAM) varied across seasons in a similar manner to AFDM. Predicted DAM's of Hydrobia 1, 1.5, 2, 2.5 and 3 mm long, interpolated from regression equations relating DAM with body length in

Table 3

Coefficients (b) and constants (a) from regression equations of the form $\text{Log}_e \text{AFDM (mg)} = a + b \text{log}_e (c)$ for Redshank prey (where (c) equals body length in Hydrobia ulvae and Corophium volutator in mm. and body width in Macoma balthica in mm)

| Species | Season | Regression coefficient (b) | Regression constant (a) | r ² | n |
|--------------------|--------------|----------------------------|-------------------------|----------------|----|
| <u>H ulvae</u> | Autumn | -2 16 | 2.21 | 52.4 | 45 |
| | Early Winter | -2 02 | 1.88 | 69.5 | 57 |
| | Late Winter | -4.16 | 1.19 | 54.2 | 42 |
| | Spring | -4 20 | 2.49 | 69.3 | 82 |
| <u>M Balthica</u> | Autumn | -2.28 | 1.74 | 82.6 | 54 |
| | Early Winter | 1.95 | -2 62 | 82.6 | 76 |
| | Late Winter | 1.24 | -0 741 | 85.3 | 43 |
| | Spring | 2.73 | -4.18 | 86.1 | 63 |
| <u>C volutator</u> | Autumn | 0.088 | -1.6 | 74.8 | 15 |
| | Early Winter | 1 91 | -1.98 | 29.4 | 24 |
| | Late Winter | 1 83 | -3.22 | 56 0 | 41 |
| | Spring | 1.6 | -3 31 | 62.9 | 27 |

Hydrobia ulvae

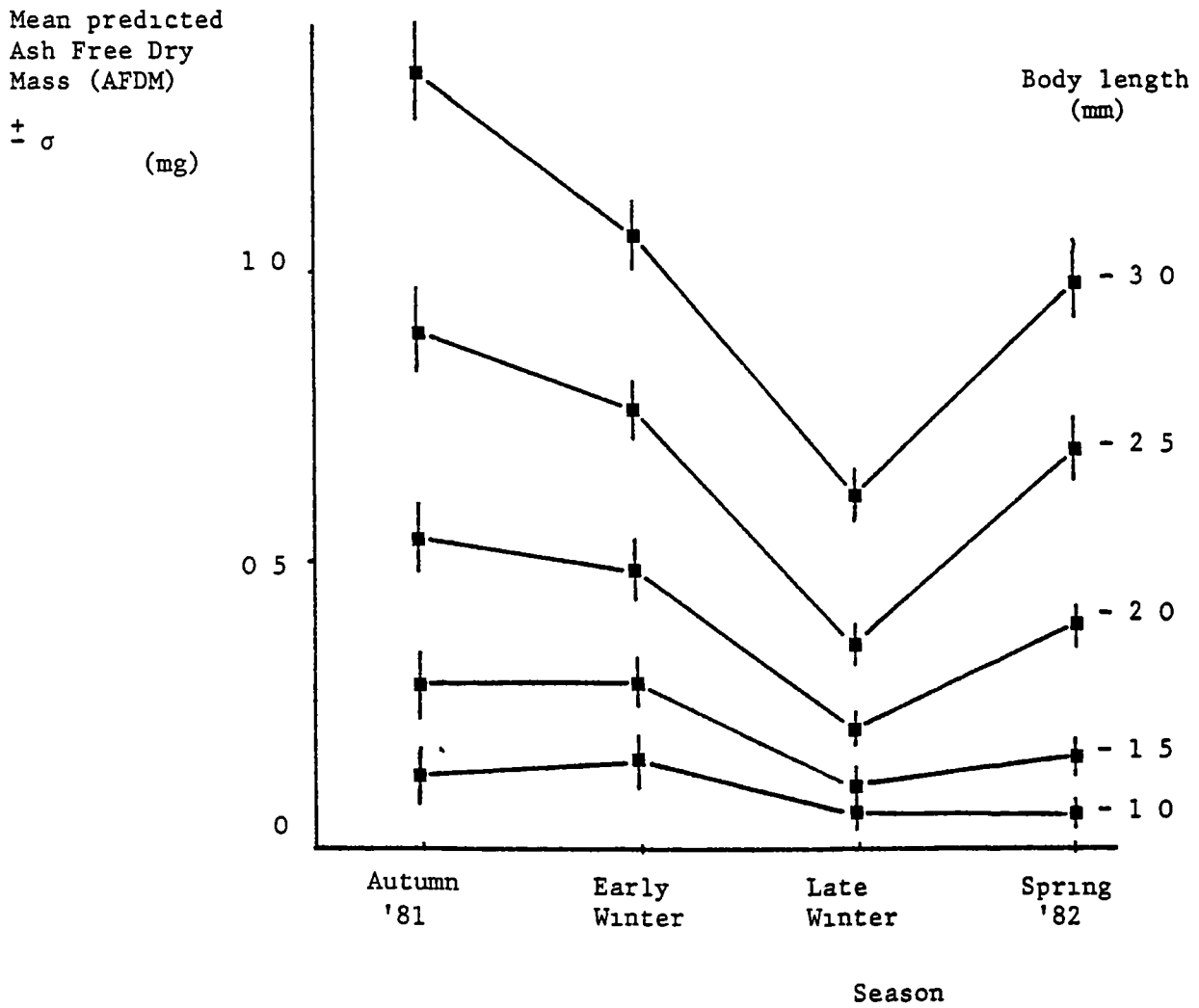

Fig 25 Temporal variation in Ash Free Dry Mass (AFDM) of five standard size Hydrobia ulvae. Predicted AFDMs interpolated from relationships between AFDM and body length in each season (see Table 3). Data from Skinflats and Culcross pooled.

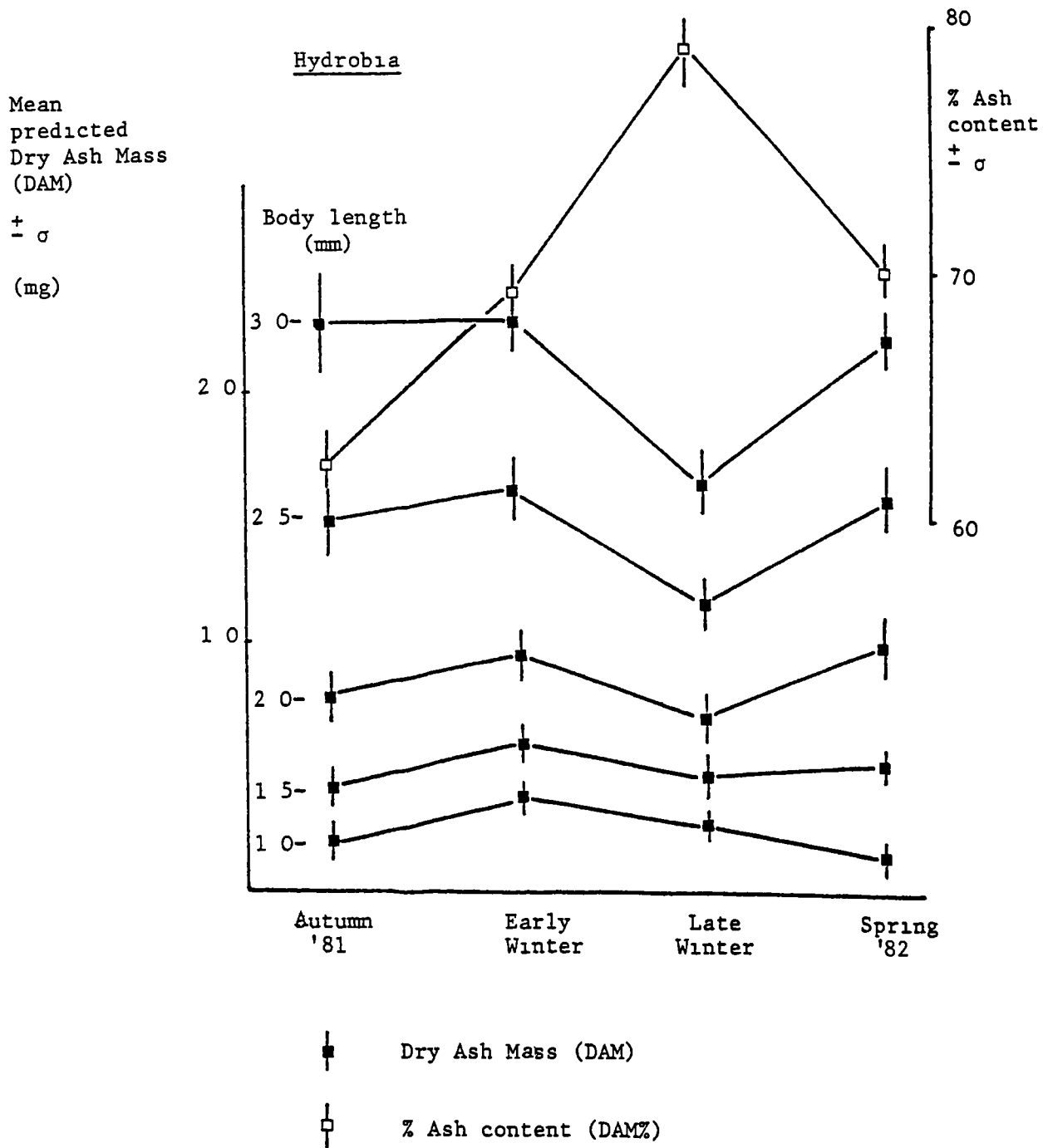

Fig 26 Temporal variation in Dry Ash Mass (DAM) of five standard size Hydrobia ulvae (closed symbols) Predicted DAM interpolated from relationships between DAM and body length in each season Temporal variation in % ash content (DAM%), across all size classes (open symbols) is also shown Data from Skinflats and Culcross pooled

each season are shown in Fig. 26. Expressed as a percentage of total dry mass (=AFDM + DAM), DAM% was independent of body length in all seasons ($r^2 \times 100$ between length and DAM% - Autumn = 3.1%, Early Winter = 5.8%, Late Winter = 1.5%, Spring = 3.4%, p for all r values $> .05\%$).

Although seasonal variation of DAM and AFDM was similar, changes in AFDM were relatively smaller, e.g. the DAM in Late Winter averaged 75% ($\sigma = 7.8\%$) of the DAM in Autumn, less than half the decrease in AFDM (above). In consequence the mean DAM% was greatest in Late Winter ($\bar{x} = 77.1\%$, $\sigma = 8.2\%$), when both DAM and AFDM were at seasonal minima and lowest in Autumn (mean = 62.8%, $\sigma = 9.8\%$), when DAM and AFDM were at seasonal maxima (Fig. 26)

(3.3.2) Corophium volutator

All analyses refer to animals from Skinflats.

(a) Ash free dry mass

In all seasons there was a significant positive, curvilinear relationship between AFDM and body length (Table 3). Predicted AFDM's for Corophium with 1.0, 2.0, 3.0, 4.0, 5.0 and 6.0 mm body lengths interpolated from these regressions are plotted against season in Fig. 27.

In Corophium with bodies longer than 4 mm the maximum AFDM occurred in Autumn, smaller animals had maximum AFDM's in Early Winter. From these peaks AFDM declined in all sizes throughout the Winter to a minimum in Spring. Across all classes, AFDM in Late Winter and Spring averaged 53.7% ($\sigma = 23\%$) and 37.5% ($\sigma = 13\%$) respectively, of the AFDM in Autumn. In both these seasons relative decreases in AFDM were inversely related to body size.

(b) Ash content

Both DAM and DAM% were independent of body length in Autumn and Early Winter. There was a significant negative relationship between

Corophium volutator

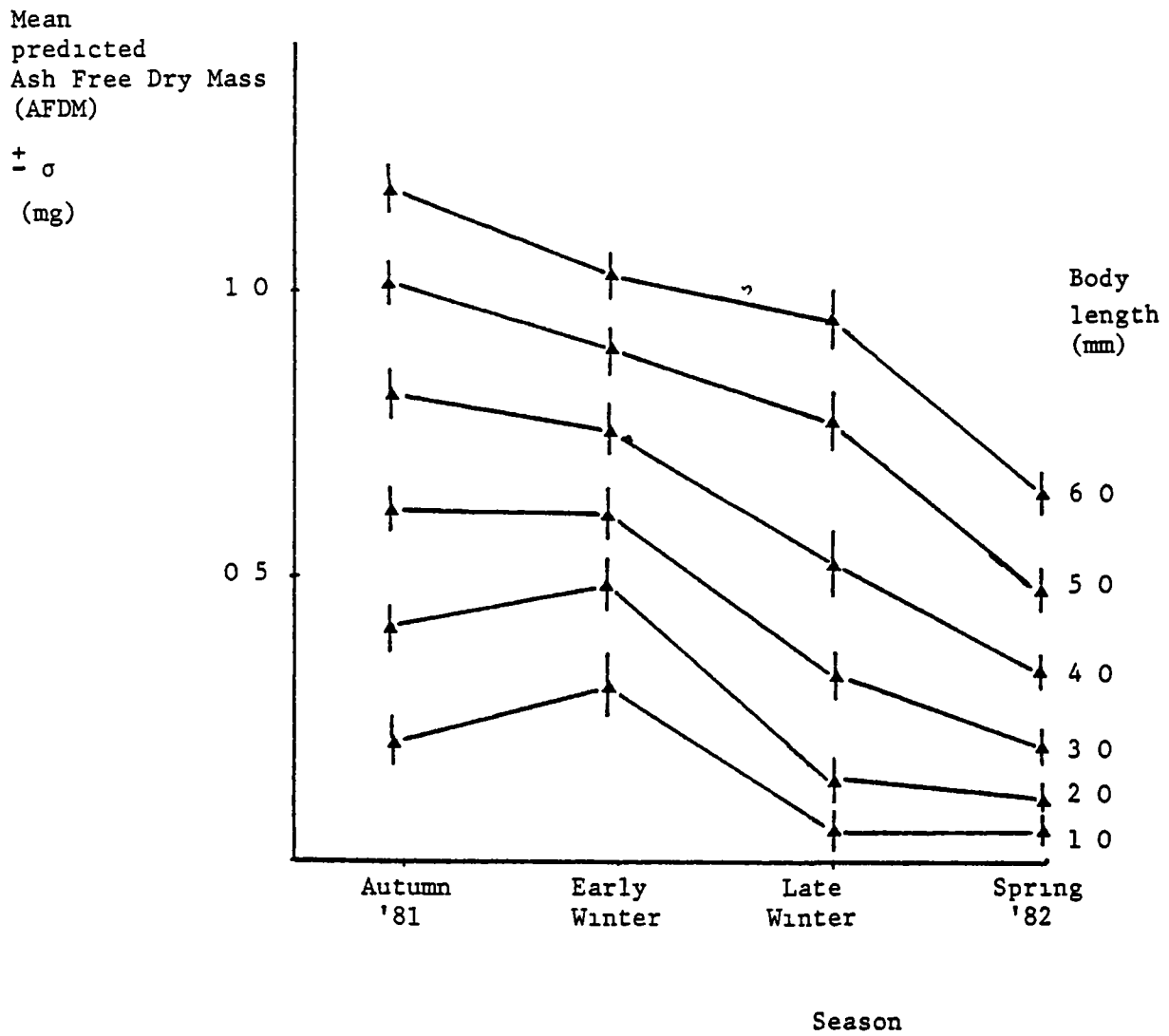

Fig 27 Temporal variation in Ash Free Dry Mass (AFDM) of six standard size Corophium volutator, at Skinflats Predicted AFDMs interpolated from relationships between AFDM and body length, in each season (see Table 3)

DAM% and body length in Late Winter ($r = 0.51$, $p < .05$) and a significant positive relationship between DAM and body length in Spring ($r = 0.62$, $p < .05$). Across sizes, DAM% was highly variable. The mean DAM% was lowest in Autumn (mean across sizes = 16.6%) and increased throughout the winter (mean Early Winter = 21.3%, mean Late Winter = 27.4%) to a maximum in Spring (mean = 31.1%).

(3.3.3) Macoma balthica

(a) Ash free dry mass

Macoma of equal body widths (Appendix 1) from Skinflats and Culross did not have significantly different AFDM's. Data across the two sites were pooled. In all seasons there was a significant non-linear positive relationship between body width and AFDM (table 3). Predicted AFDMs for Macoma of body widths 5, 10 and 15mm., interpolated from the regression equations, are plotted against season in Fig. 28.

In both large (15mm.) and medium (10mm) sized Macoma the AFDM was greatest in Spring and lowest in Autumn. Small (5mm.) Macoma had maximum AFDM in Early Winter. Relative fluctuation in AFDM increased with increasing size, hence in small Macoma the greatest AFDM was 1.61x the smallest, whilst in large Macoma the ratio was 3.1.

(b) Ash content

Unlike Oystercatchers which open Macoma shells and ingest only the flesh (Hulsher 1981), Redshank ingest both the shell and flesh. DAM therefore includes the shell mass.

There was a significant positive non-linear relationship between both DAM and DAM%, and body width, in each season. Predicted DAM% interpolated from regression equations relating DAM% and body width for animals of body width 5, 10 and 15mm. are plotted against season in Fig. 29.

Macoma balthica

Predicted
Mean
Ash Free Dry
Mass (AFDM)
($\pm \sigma$)
(mg)

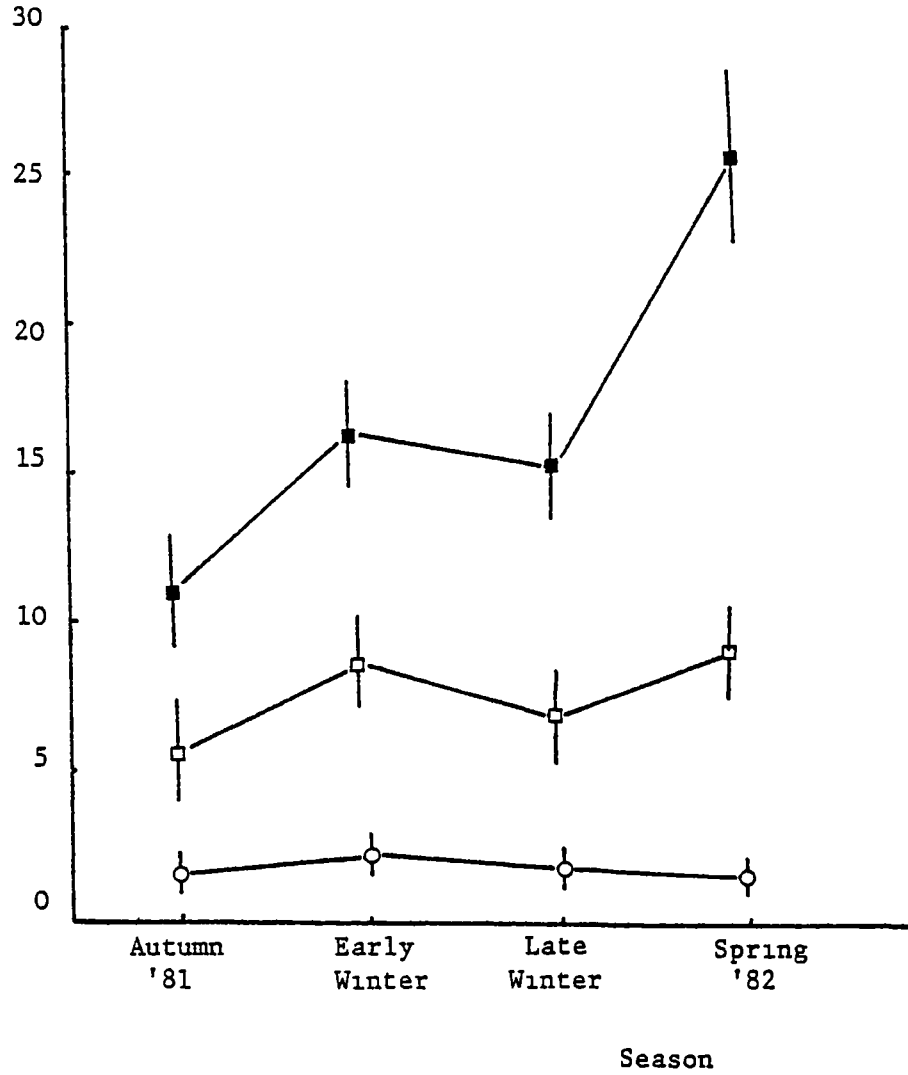

Fig 28 Temporal variation in Ash Free Dry Mass (AFDM) of three standard size Macoma balthica Predicted AFDM interpolated from relationships between AFDM and body width, in each season (see Table 3) Data from Skinflats and Culcross pooled

Macoma balthica

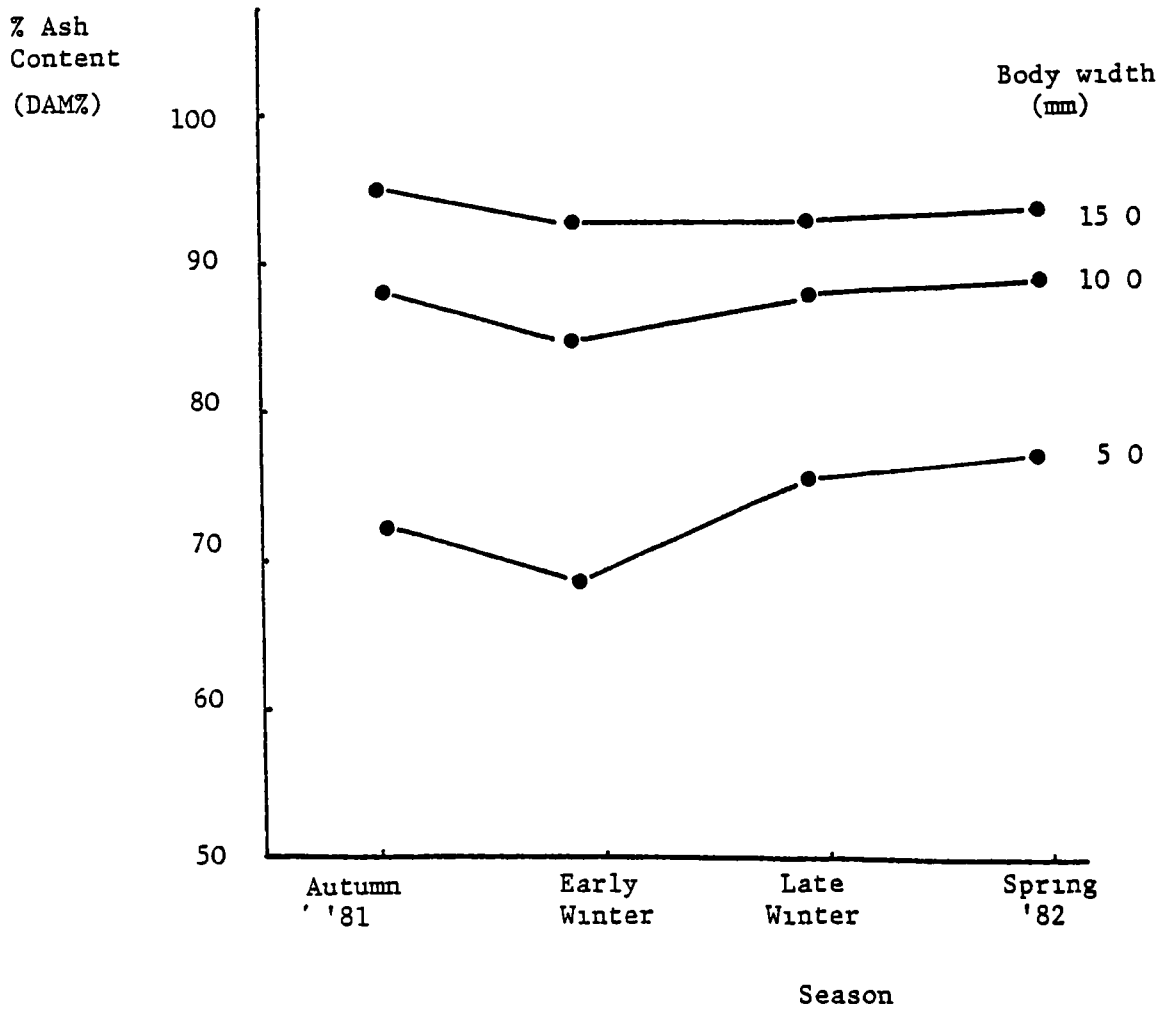

Fig 29

Temporal variation in the percentage ash content (DAM%) of three standard size Macoma balthica. Predicted DAM% interpolated from relationships between DAM% and body width. Data from Skinflats and Culross pooled.

Because the shell of Macoma is relatively large, the DAM% exceeded 65% of the total dry mass in all sizes, and exceeded 90% in the largest (15mm.) animals. The pattern of change in DAM across seasons was similar to the change in AFDM, seasonal fluctuations in DAM% were consequently relatively small.

(3.3 4) Oligocheates

Across all sites, sizes and seasons the mean AFDM of Tubificoides benedicti was 95.7 μg ($\sigma = 24.7\mu\text{g}$. $n = 28$). Temporal and spatial variability was not examined.

(3.3.5) Polycheates

AFDM and ash contents for Nephtys hombergii and Nereis diversicolor from sites adjacent to the study sites, sampled during the same seasons, were obtained from McCraw (in press).

(3.4) Prey energy content - Oystercatcher prey

(3.4 1) Mytilus edulis

Mytilus were divided into two components - flesh and shell.

(a) Flesh

(1) Ash free dry mass

Ash free dry mass was entered as the dependent variable in multiple regression analyses in each plot in each season. Allometric parameters of the mussel shells - body length, body weight and body width (Appendix 1) were entered as independent variables. At all plots, in all seasons, there was a significant non-linear relationship between AFDM and shell length. Fitted regression equations on logarithmic transformed variables explained between 70 and 93% of the variability in AFDM. (Table 4) Significant independent effects of body height and body width were not found at any site.

Table 4

Coefficients and constants of fitted regression equations of the form $\log_e \text{AFDM (g)} = a + b \log_e (\text{length})$ for Mytilus edulis, across both plots and seasons.

| Season ¹ | Plot ² | Bed ² | Regression Constant (a) _± | Regression Coefficient (b) _± | r ² | n |
|---------------------|-------------------|------------------|---|--|----------------|----|
| Autumn | 3 | U | -5.19 (0.08) | 2.26 (0.09) | 91.4 | 30 |
| Early Winter | 1 | U | -6.3 (0.28) | 2.87 (0.10) | 90.5 | 21 |
| | 3 | U | -5.39 (0.31) | 2.85 (0.10) | 92.2 | 28 |
| | 4 | U | 5.64 (0.2) | 2.58 (0.15) | 91.0 | 21 |
| | 5 | L | -6.38 (0.26) | 2.98 (0.18) | 92.5 | 27 |
| | 6 | L | -6.83 (0.21) | 3.2 (0.29) | 77.5 | 21 |
| | 7 | L | -5.14 (0.16) | 2.05 (0.21) | 82.6 | 31 |
| | 9 | L | -5.62 (0.19) | 2.55 (0.18) | 85.1 | 28 |
| Late Winter | 2 | U | -5.53 (0.09) | 2.37 (0.14) | 87.7 | 26 |
| | 3 | U | -5.46 (0.09) | 2.43 (0.10) | 80.4 | 20 |
| | 4 | U | -5.53 (0.10) | 2.56 (0.16) | 95.4 | 15 |
| | 5 | L | -5.92 (0.08) | 2.73 (0.14) | 82.7 | 40 |
| | 6 | L | -5.96 (0.09) | 2.64 (0.12) | 89.8 | 15 |
| | 7 | L | -5.22 (0.10) | 2.2 (0.21) | 80.1 | 15 |
| | 8 | L | -5.18 (0.14) | 2.16 (0.16) | 70.0 | 15 |
| | 9 | L | -5.57 (0.09) | 2.63 (0.10) | 79.3 | 30 |
| Spring | 3 | U | -5.19 (0.10) | 2.18 (0.09) | 90.3 | 29 |
| | 9 | L | -5.11 (0.18) | 2.15 (0.14) | 94.8 | 29 |

1 - see section 2.2.1

2 - see section 2.2.1 figure 6

(ii) Spatial variability in AFDM

Predicted AFDM for Mytilus of shell length 30, 50 and 70 mm interpolated from the Late Winter regression equations, are shown in Fig. 30, against location.

The variation in AFDM with location was similar in all three sizes. However, relative fluctuations were greater in the larger sizes. The minimum AFDM for mussels of a given size occurred roughly in the centre of each bed, opposite the pier (Fig. 7). Lateral deviations along each bed to the east or west resulted in increased AFDM. At a given lateral deviation differences between the upper and lower beds were not significant in any size class.

The flesh content of 70 mm mussels at plot 5 (Fig. 7), with the highest mass mussels, was 42% greater than the flesh content at plot 2, with the lowest mass mussels.

(iii) Temporal variation in AFDM

Complete comparative seasonal variations in AFDM were only taken for plot 3 (Fig. 7). Predicted AFDM for mussels of shell length 30, 50 and 70 mm interpolated from regression equations at this site are plotted against season in Fig. 31.

Seasonal fluctuations in AFDM were relatively smaller than spatial variations. In the largest class the seasonal maximum AFDM (Late Winter) was 23% greater than the seasonal minimum (Spring), approximately half the % mass difference between high mass (plot 5) and low mass (plot 2) plots in Late Winter (above).

(iv) Ash content

DAM% was independent of all allometric variables, at all plots, in all seasons. Differences between plots were not significant. Across both seasons and plots the mean DAM% equalled 20.2% ($\sigma = 4.86\%$, $n = 390$).

MYTILUS

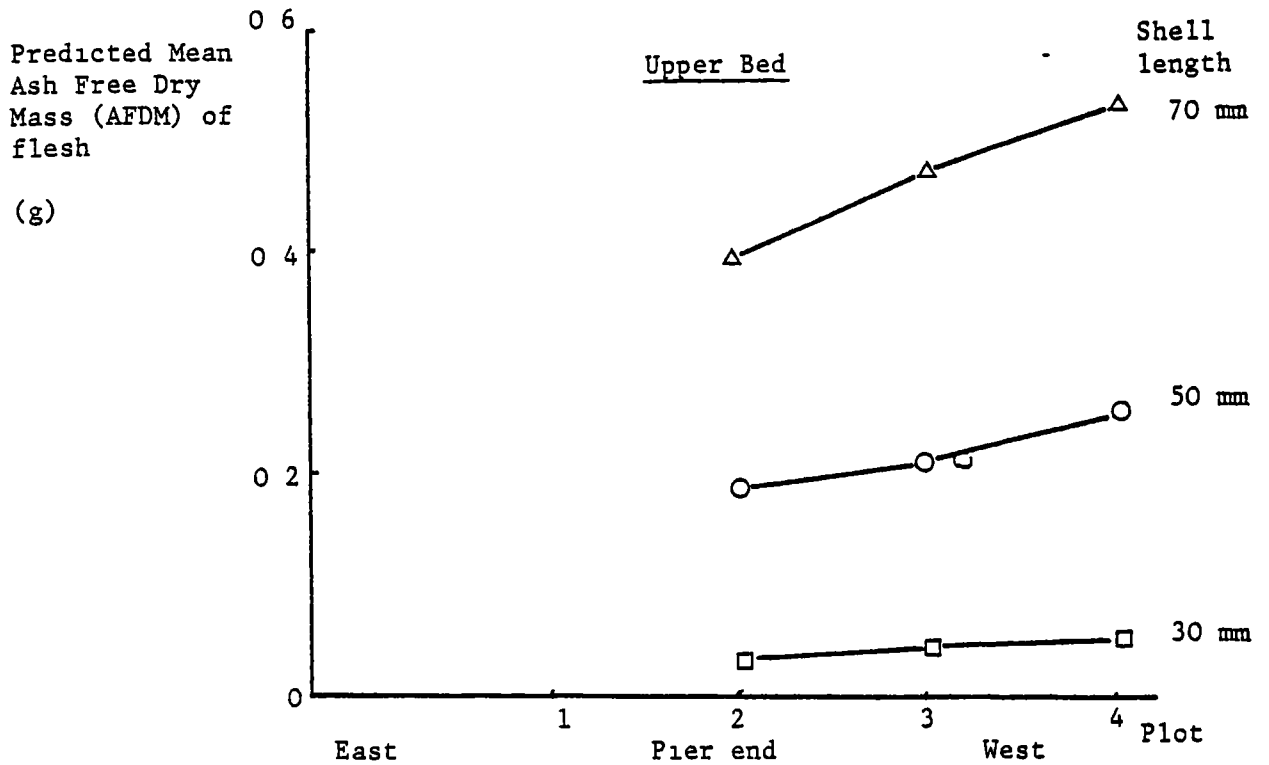
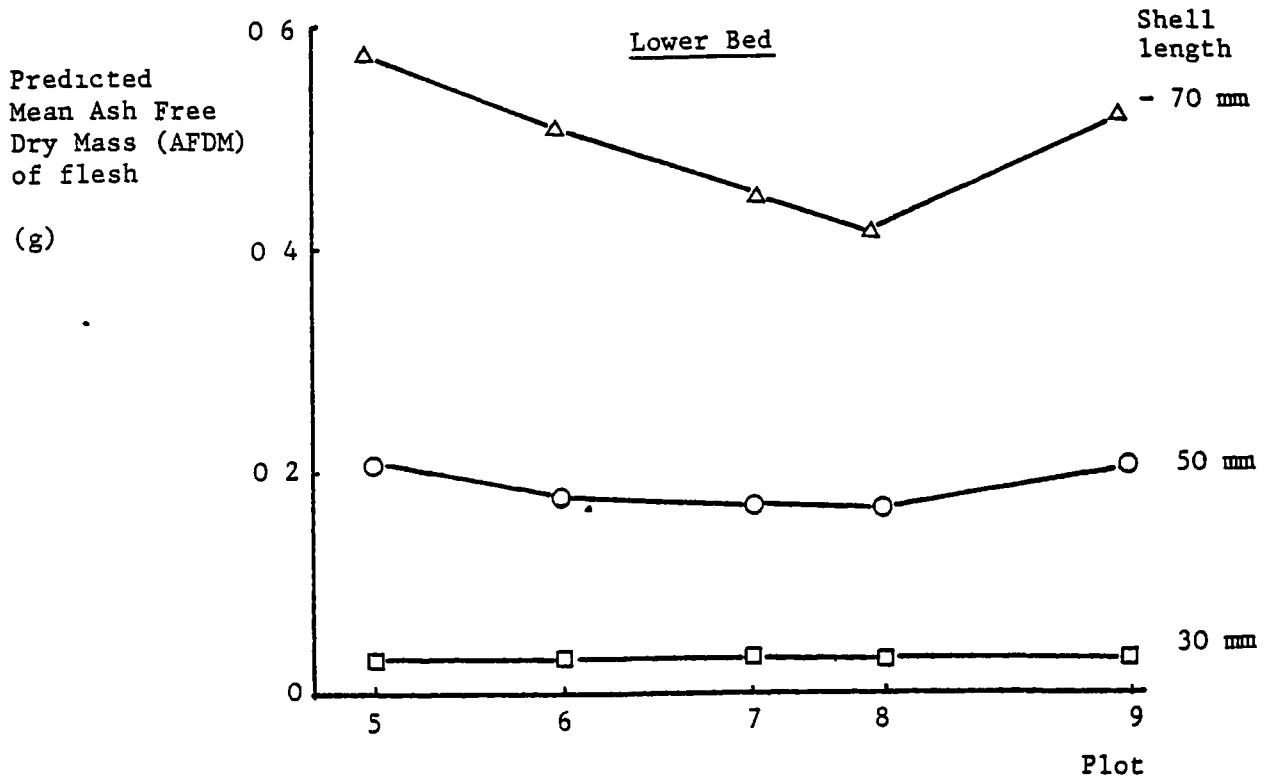

Fig 30

Predicted mean Ash Free Dry Mass (AFDM) of mussel flesh for three standard size mussels against spatial location AFDM interpolated from relationships between mussel length and AFDM at each plot in Late Winter (Table 5) For further details of plot positions, see Fig 7

Predicted Mean
Ash Free Dry
Mass (AFDM) of
flesh

(g)

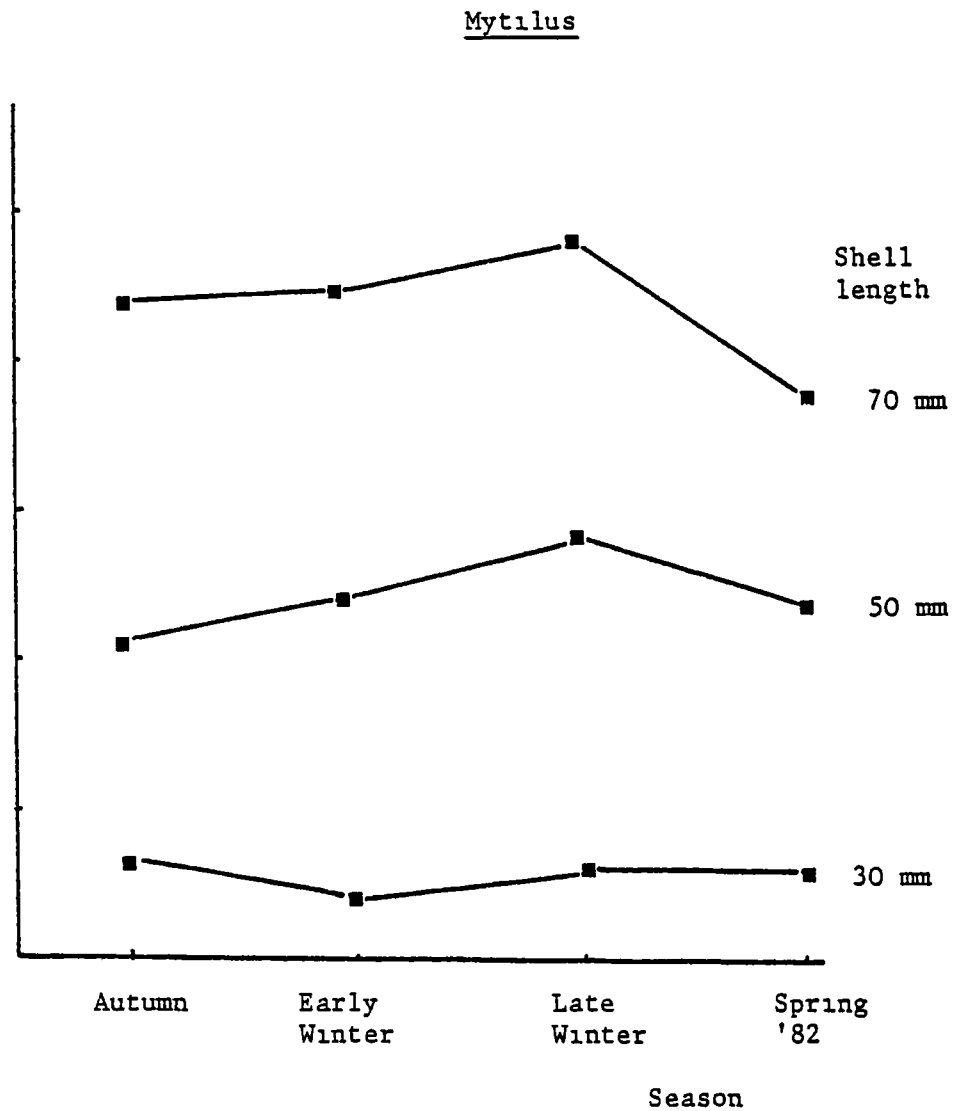

Fig 31 Temporal variation in the Ash Free Dry Mass (AFDM) of three standard size mussels at plot 3, upper bed Predicted AFDM interpolated from relationships between mussel length and AFDM in each season See Fig 7 for position of plot

(b) Shells

(i) Ash free dry mass

AFDM was calculated for a range of shell sizes (0.6 - 7.7 cm), collected across plots and seasons. The AFDM% was linearly related to the log of shell length (Fig. 32). The regression equation $y(\text{AFDM}\%) = 6.93 - 5.93 \log_e \text{ length (mm)}$, explained 62.9% of the variability in AFDM.

Total dry shell mass was entered as the dependent variable in multiple regression analyses in four plots, in Late Winter. The allometric variables body length, height and width were entered as independent variables. At all four plots there was a significant non-linear relationship between dry shell mass and shell length. Fitted regression equations on logarithmic transformed data explained over 90% of the variability in shell mass. Significant independent effects were found for either or both the other variables at all plots (Table 5).

Predicted shell masses for given allometric variables were not significantly different across all four plots.

Predicted mean shell masses were interpolated from the regression equations for mussels of body length 30, 50 and 70 mm, using relationships between shell length and shell height/width to predict the mean values of other dependent variables in the equations. Mean shell AFDM was then calculated by multiplying the predicted mean shell mass by the predicted %AFDM (above) and compared with predicted mean flesh AFDM at the same sites (Table 6).

Although shells consisted almost entirely of inorganic matter (95% in 83% of mussels over 20 mm long), they had a much greater mass than the internal flesh, consequently the organic portion of the shells formed a significant part of the total organic content. Across all sizes and

Table 5

Coefficients and constants of fitted multiple regression equations of the form

$\log_e \text{ Shell mass} = a + b_1 \log_e \text{ length} + b_2 \log_e \text{ height} + b_3 \log_e \text{ breadth}$
at four plots in late winter.

| Plot | Bed | Regression Constant a | Regression Coefficient b_1 | Regression Coefficient b_2 | Regression Coefficient b_3 | mult. r^2 | n |
|------|-----|-----------------------------|------------------------------------|------------------------------------|------------------------------------|----------------|----|
| 5 | L | -0 616 | 1 02 | 0 731 | 1.51 | 98.6 | 40 |
| 7 | L | -0 744 | 1 60 | n s. ¹ | 1 51 | 99.0 | 15 |
| 3 | W | -0 912 | 2 08 | n s. | 1.09 | 98.5 | 15 |
| 4 | W | -0 675 | 1.49 | n.s | 1.52 | 99.7 | 30 |

¹ n s. = variable not significant

Table 6

Predicted mean shell and flesh AFDM for mussels of shell lengths 7.0, 5.0 and 3.0 cm, at four plots in Late Winter.

| Plot | Bed | Body Length (cm) (shell) | \bar{x} AFDM (Flesh) | \bar{x} AFDM (Shell) | $\frac{\text{AFDM (shell)}}{\text{AFDM (shell + flesh)}}$ |
|------|-----|-----------------------------|---------------------------|---------------------------|---|
| 5 | L | 3.0 | 0.055 | 0.056 | 0.505 |
| | | 5.0 | 0.213 | 0.214 | 0.501 |
| | | 7.0 | 0.588 | 0.464 | 0.441 |
| 7 | L | 3.0 | 0.063 | 0.054 | 0.4611 |
| | | 5.0 | 0.174 | 0.217 | 0.555 |
| | | 7.0 | 0.455 | 0.480 | 0.513 |
| 3 | U | 3.0 | 0.098 | 0.059 | 0.3757 |
| | | 5.0 | 0.220 | 0.229 | 0.510 |
| | | 7.0 | 0.488 | 0.497 | 0.505 |
| 4 | U | 3.0 | 0.107 | 0.063 | 0.369 |
| | | 5.0 | 0.254 | 0.223 | 0.467 |
| | | 7.0 | 0.543 | 0.453 | 0.455 |
| | | | | | <hr/> |
| | | | | | \bar{x} 0.471 |
| | | | | | σ 0.056 |
| | | | | | n 12 |

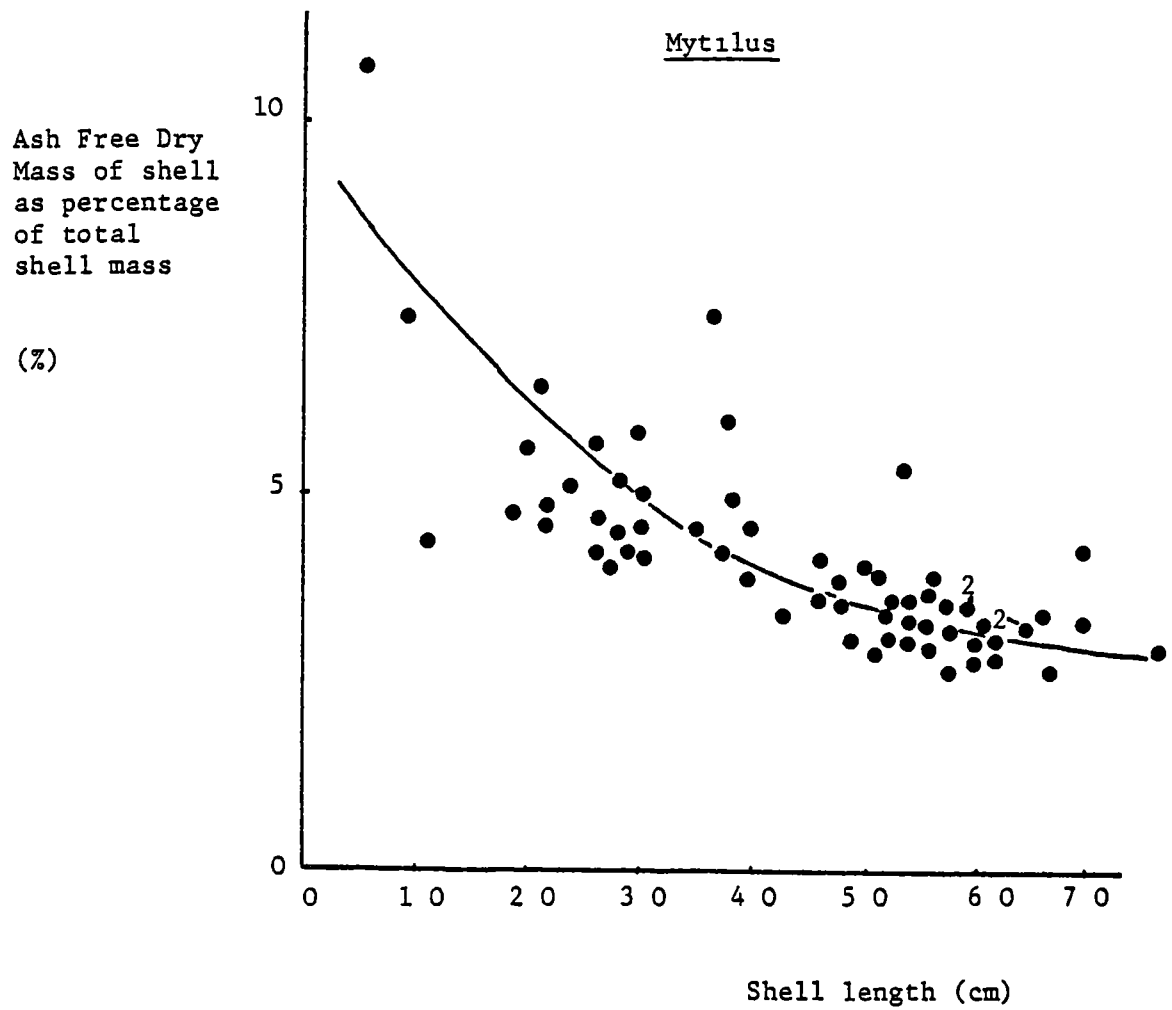

Fig 32 Percentage organic (AFDM) content of Mytilus edulis shells against shell length (cm) The curve describes the least squared fit regression

$$y = 6.93 - 5.36 \log_e x$$

$$n = 64$$

$$r^2 = 0.65$$

$$F = 25.4$$

$$p < 0.1$$

plots the shell AFDM averaged 47% of the total AFDM (Table 6).

(a) Incomplete ingestion

The percentage of the total flesh left behind in mussel shells, by foraging oystercatchers, was independent of shell length ($r = -0.114$, $p > .05$, $n = 52$), and averaged 7.59% ($\sigma = 2.62\%$, $n = 52$).

(3.5) Biochemical and calorific contents

(a) Biochemical composition

Mean percentage Protein, Carbohydrate (CHO) and Lipid contents for all prey are shown in Table 7. Protein content varied between 21.7% (Hydrobia - Early Winter) and 62.9% (Corophium - Late Winter). Corophium and Nereis had the highest protein contents (Mean = 55.8%). Bivalves (Macoma and Mytilus) had a mean protein content of 32.9%. Hydrobia had the lowest mean protein content (26.7%). Across all species and seasons there was a significant non-linear inverse relationship between the % Protein and % Carbohydrate content ($r = -0.855$, $p < .05$).

% Lipin content varied between 0 (Macoma - Late Winter) and 36.8% (Hydrobia - Early Winter). % Lipid content was independent of % protein content ($r = 0.264$, $p > .05$) but inversely related to %CHO content ($r = -0.731$, $p < .05$).

Changes in % protein and % CHO between Early and Late winter differed between species, and within species at different sites. In the bivalves % protein remained almost consistent (\bar{x} Early Winter = 33.07, Late Winter = 32.07%) whilst %CHO content increased (\bar{x} Early Winter = 49.92%, \bar{x} Late Winter = 59.7%). Similar changes were recorded for Hydrobia at Culross, but opposite trends were recorded for both Hydrobia and Corophium at Skinflats. % Lipid content decreased between Early and

Table 7

Mean percentage, protein, carbohydrate and lipid contents of all prey across sites and seasons.

| Species | Site ¹ | Season ² | % Protein | % Carbohydrate | % Lipid |
|-----------|-------------------|---------------------|-----------|----------------|---------|
| Corophium | S | EW | 51.3 | 25.3 | 23.3 |
| | | LW | 62.9 | 18.1 | 19.4 |
| Hydrobia | S | EW | 21.7 | 41.7 | 36.6 |
| | | LW | 32.0 | 37.1 | 31.0 |
| | C | EW | 27.3 | 61.6 | 11.0 |
| | | LW | 25.8 | 54.7 | 9.4 |
| Macoma | S | EW | 29.5 | 59.2 | 11.31 |
| | | LW | 29.0 | 63.4 | 7.6 |
| | C | EW | 31.8 | 49.7 | 18.5 |
| | | LW | 30.8 | 68.2 | 0 |
| Nereis | C | LW | 53.18 | 19.14 | 27.68 |
| Mytilus | C | EW | 39.8 | 40.8 | 19.3 |
| | | LW | 36.4 | 47.3 | 16.3 |
| <hr/> | | | | | |
| | | x | 36.3 | 45.9 | 17.8 |
| | | σ | 12.3 | 17.4 | 10.2 |
| | | n (all species) | 13 | 13 | 13 |
| <hr/> | | | | | |

Late Winter in all the species ($p = 0.03$, Sign test).

(b) Energy content

Calorific contents for all prey estimated by both methods (2.5.4.3) are shown in Table 8. Differences between the two methods averaged only 3.95%. The mean calorific content, across methods, varied between 27.6 kJ.g^{-1} AFDM (Hydrobia - Early Winter) and 17.87 kJ.g^{-1} AFDM (Macoma - Late Winter) and averaged 23.3 kJ.g^{-1} AFDM, across all animals and seasons. Changes in calorific contents between Early and Late Winter were generally small - only one exceeded 6%, but in 5 of 6 cases were negative ($p = 0.06$, Sign test).

(3.6) The relative importance of changes in prey density, prey mass size distribution and calorific content on the gross energy availability to wading birds throughout the winter

Total Biomass (B_t) of each species was calculated as follows

$$B_t = \sum_{k=1}^n d_k \cdot m_k \quad (29)$$

where d_k = density of the kth size class

m_k = the mass of the kth size class

n = the number of size classes

B_t was then converted to gross energy availability using the estimated energy contents (section 3.5). Autumn and Spring energy contents were assumed to equal 1.14x and 0.96x the mean Winter levels respectively (Calculated from seasonal changes given by Chambers and Milne (1979) for the Ythan estuary, N.E Scotland).

Gross energy availability (kJ.m^{-2}) was entered as the dependent variable in stepwise multiple regression analyses for each prey. The total prey density, mean prey size (which reflects changes in the size distribution) and calorific content, were entered as independent

Table 8

Estimated energy contents (kJ g AFDM⁻¹) of all prey across sites and seasons.

| Species | Site ¹ | Season ² | Method (1) ³ | Method (2) ⁴ | x(1) + (2) |
|-----------|-------------------|---------------------|-------------------------|-------------------------|------------|
| Corophium | S | EW | 25.7 | 25.4 | 25.5 |
| | | LW | 25.8 | 25.4 | 25.6 |
| Hydrobia | S | EW | 26.8 | 28.3 | 27.6 |
| | | LW | 26.2 | 27.7 | 27.0 |
| | C | EW | 21.4 | 20.1 | 20.8 |
| | | LW | 21.0 | 20.8 | 20.9 |
| Macoma | S | EW | 21.7 | 20.9 | 21.3 |
| | | LW | 18.9 | 19.3 | 19.1 |
| | C | EW | 23.5 | 23.3 | 23.4 |
| | | LW | 19.7 | 16.0 | 17.9 |
| Nereis | C | EW | 26.9 | 26.6 | 26.8 |
| Mytilus | C | EW | 24.0 | 24.1 | 24.1 |
| | | LW | 23.2 | 23.1 | 23.2 |

1 S = Skinflats, C = Culross

2 EW = Early Winter, LW = Late Winter

3 Method One - predicted from biochemical composition

4 Method Two - predicted from percentage carbon content after Salonen et al
(1977)

variables. Any residual variability after the inclusion of all variables was a result of changes in the size specific mass. Sites with no prey were excluded from the analysis.

(a) Redshank prey

In Hydrobia, Corophium and Macoma the major variability in gross energy availability was explained by changes in prey density and size specific mass (Table 9). In combination, these effects explained 97.7%, 84.6% and 98.85% of the variability in energy availability of Hydrobia, Macoma and Corophium respectively. Changes in the calorific content and mean size of prey were relatively unimportant.

(b) Oystercatcher prey

In Mytilus the major variability in gross energy availability was explained by changes in prey density and the mean mussel size, which together explained 91.8% of the variability (Table 9). Almost all the remaining variability was explained by changes in the size specific mass content, whilst changes in calorific content were unimportant.

(3 7) Assimilation efficiency

Mean assimilation efficiencies for Redshank feeding on Blowfly larvae and pupae, sardines and Hydrobia, and Oystercatchers feeding on Mytilus, are shown in Table 10. There was a significant non-linear inverse relationship between the mean proportion of a given prey assimilated and the inorganic ash content of the prey (Fig. 33). The regression equation $\log_e \text{ proportion assimilated} = -0.0147 - 0.0801 \log_e \% \text{ inorganic ash (= DAM\%)}$, explained 95.6% of the variability in mean assimilation efficiency ($F = 65.75, n = 5, p < 01$).

Table 9

The percentage variability in energy availability (kJ m^{-2}), across seasons and sites, explained by changes in the prey density, mean prey size, calorific content and size specific mass for four prey - Hydrobia ulvae, Macoma balthica, Corophium and Mytilus edulis.

| Independent variable | Hydrobia | Species Macoma | Corophium | Mytilus |
|----------------------|----------|----------------|-----------|---------|
| Prey density | 76 37 | 46 57 | 56 64 | 71.23 |
| Size specific mass | 21 29 | 38.00 | 42.21 | 8.08 |
| Calorific content | 1.54 | 6 42 | 0 01 | 0.03 |
| Mean size | 0.81 | 9 01 | 1.14 | 20 57 |

Table 10

Assimilation efficiencies for Blowfly (Calliphora) larvae and pupae, Sardines (Sardinia pilchardus) and Hydrobia when eaten by Redshank, and for Mytilus flesh when eaten by Oystercatcher (n equals number of determinations for the predator/prey combination.)

| Predator | Prey | \bar{x} assimilation % | σ | n determinations |
|---------------|-----------------|--------------------------|----------|------------------|
| Redshank | Blowfly larvae | 89.0 | 9.8 | 10 |
| " | Blowfly pupae | 84.8 | 10.5 | 30 |
| " | Sardines | 80.94 | 5.7 | 10 |
| " | <u>Hydrobia</u> | 71.26 | 2.3 | 27 |
| Oystercatcher | <u>Mytilus</u> | 79.5 | 2.4 | 29 |

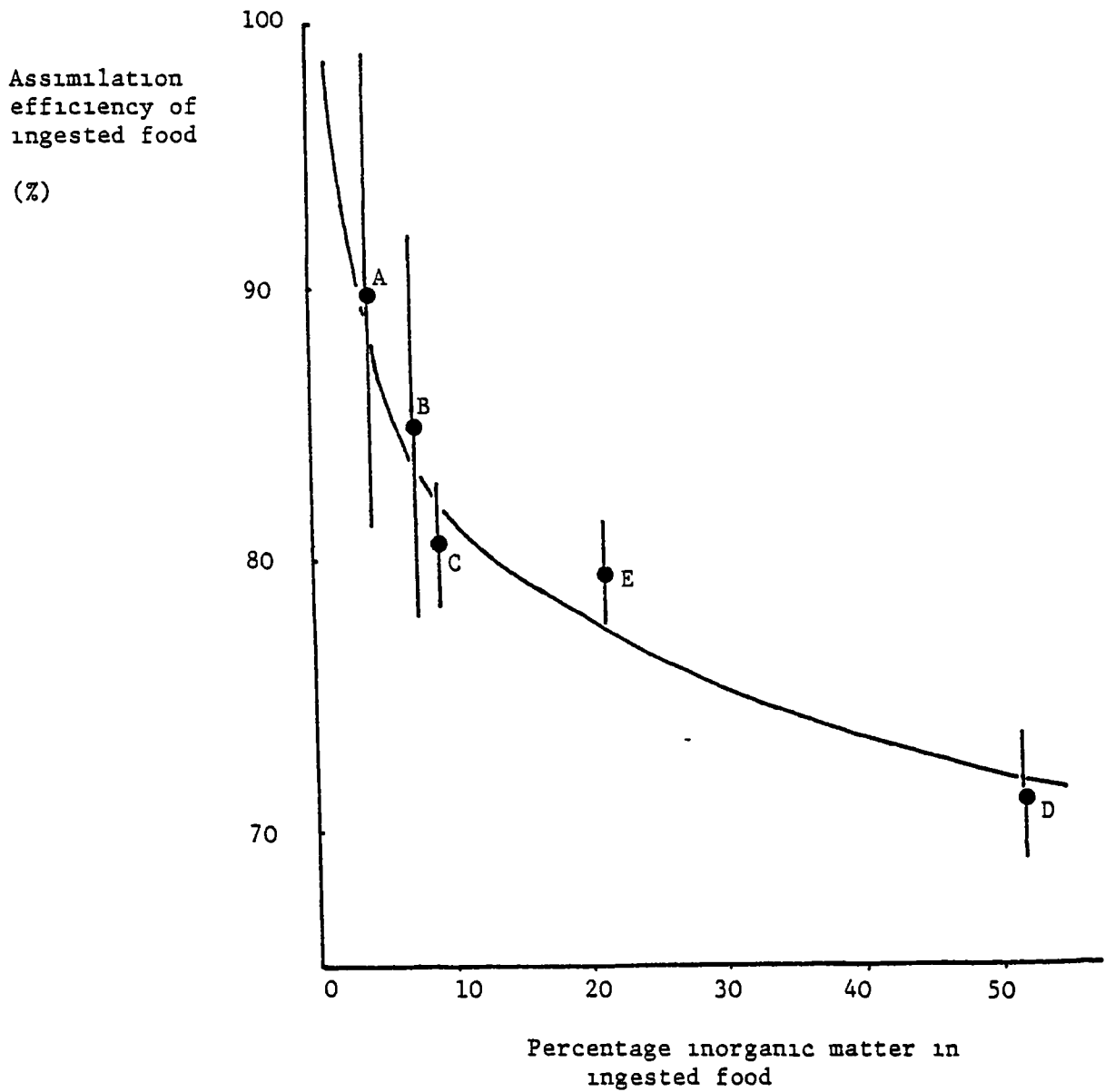

Fig 33 Assimilation efficiencies of five prey against inorganic ash content. Assimilation efficiency equals percentage of Ash Free Dry Mass assimilated, and inorganic ash content equals ash as percentage of total mass in ingested food. Curve fitted to means describes the relationship

$$\log_e y = -0.0147 - 0.0801 \log_e x$$

$$\begin{aligned} n &= 5 \\ r^2 &= 0.956 \\ F &= 65.75 \\ p &< .01 \end{aligned}$$

| | <u>Prey</u> | <u>Predator</u> |
|---|-----------------|-----------------|
| A | Blowfly larvae | Redshank |
| B | Blowfly pupae | " |
| C | Sardines | " |
| D | <u>Hydrobia</u> | " |
| E | <u>Mytilus</u> | Oystercatcher |

(a) Test that ash is not assimilated

The mean ash content of sardines was 7.28% ($\sigma = .63\%$ $n = 10$) whilst the ash content of the faeces averaged 31.04% ($\sigma = 5.7\%$, $n = 10$). Over three independent 24 hour periods the total dry mass assimilation averaged 72.97% ($\sigma = 6.0\%$). Of each ten grams of prey ingested therefore the birds ingested 0.728 grams of ash ($\sigma = 0.263$) and egested 2.73 grams of faeces ($\sigma = 0.6$ g) of which 0.84 grams ($\sigma = 0.15$ g) was inorganic ash. Estimates of ingested and egested inorganic ash were not significantly different ($t = 1.17$, $p > .05$). It is concluded inorganic ash is not assimilated.

(3.8) Prey availability(3.8.1) Visually foraging Redshank(a) Hydrobia ulvae(1) Surface availability

Surface numbers of Hydrobia, as a percentage of those in the upper 6 cm of the substrate, significantly increased with increasing mud temperature, decreased with both increasing hours since tidal exposure and air temperature, and were independent of Hydrobia density (Table 11).

Mud temperature increased with both hours since exposure and air temperature, probably because of increasing absorbance of radiant heat with hours exposed, and decreasing dissipation with increasing air temperature. Substituting predictions of mud temperatures into the regression equation (Table 11) the proportion of Hydrobia available at the surface, throughout the tidal cycle at four air temperatures (0.5, 10 and 15°C) was predicted (Fig. 34).

At low temperatures (0°C) almost all Hydrobia were buried beneath the surface. As temperature increased the proportion at the surface on

Table 11

Coefficients and constants from multiple regression equations of surface availability (proportion of animals exposed at the surface) and surface cue availability (proportion of animals revealed by surface cues, e.g. burrows) on mud and air temperatures, time since tidal emersion and prey density, for Hydrobia, Corophium and Macoma

| <u>Species</u> | Regression Constant | Coefficients ¹ | | | | Equation Type |
|--------------------------|------------------------|-------------------------------|------------------|----------------|----------------|------------------|
| | | <u>Dependant Variable</u> | b ₁ | b ₂ | b ₃ | |
| <u>Hydrobia</u> | | | | | | |
| Surface available | 0.664 | 0 510 | -0.332 | -0 532 | n.s. | LOG |
| Surface cue available | -0.427 | 0 0833 | n s ² | 0 316 | -0.003 | LOG |
| <u>Corophium</u> | | | | | | |
| Surface available | 0 275 | 0.201 | -0.12 | -0 227 | n s | LOG |
| Surface cue available | -0 49 | 0.23 | -0.103 | 0.329 | -0 026 | LOG |
| <u>Macoma</u> | | | | | | |
| Surface available | 0 0134 | -0 01 | -0 0093 | -0.01 | 0 0075 | LIN |

- 1 b₁ = mud temperature (°C)
 b₂ = air temperature (°C)
 b₃ = hours exposed (n)
 b₄ = density (nm⁻²)

2 n s = variable excluded as not significant

3 LOG = equation with all variables logarithmic transformed to base e
 except density
 LIN = all variables linear

Percentage
available on
the mud surface

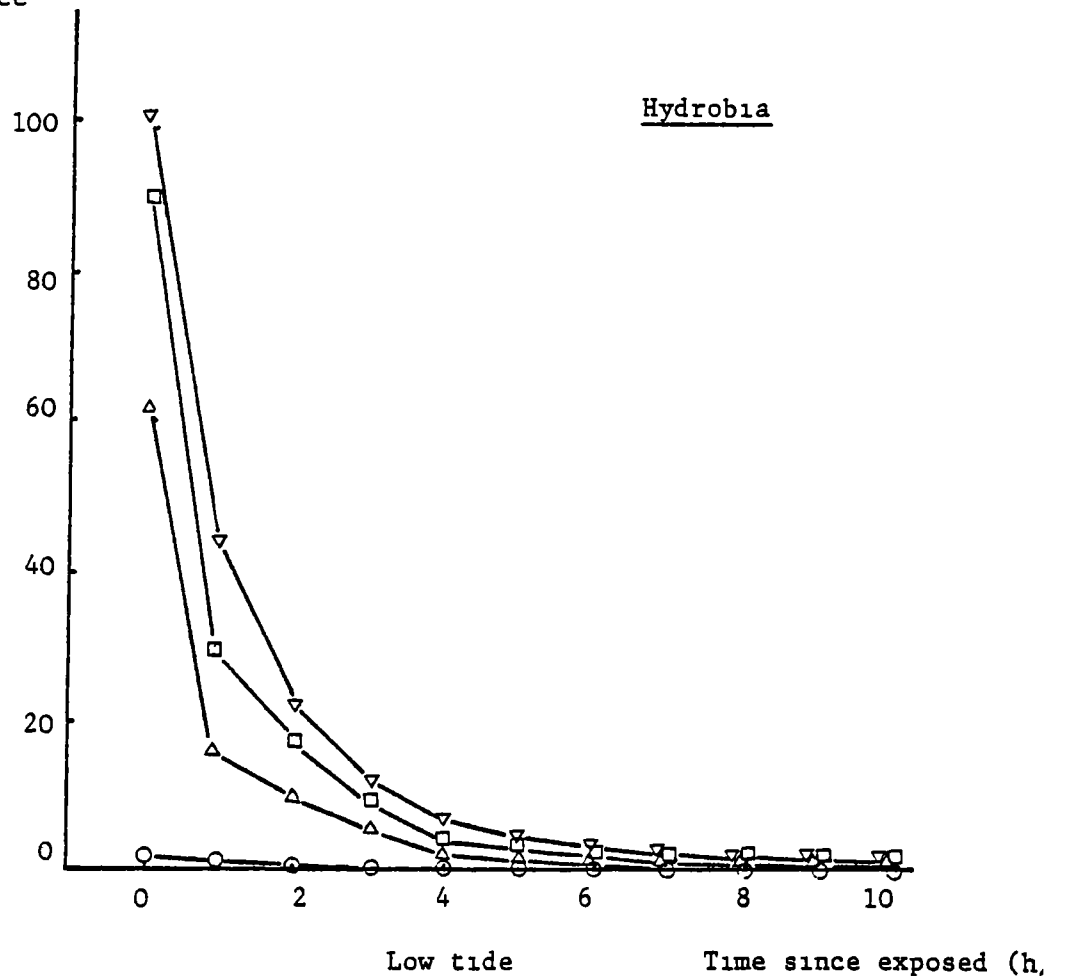

Air temperature

- ▽ 15°C
- 10°C
- △ 5°C
- 0°C

Fig 34 Predicted percentage of Hydrobia ulvae available on the mud surface, throughout the tidal cycle, at four air temperatures. See Table 7 for predictive equation.

Percentage available

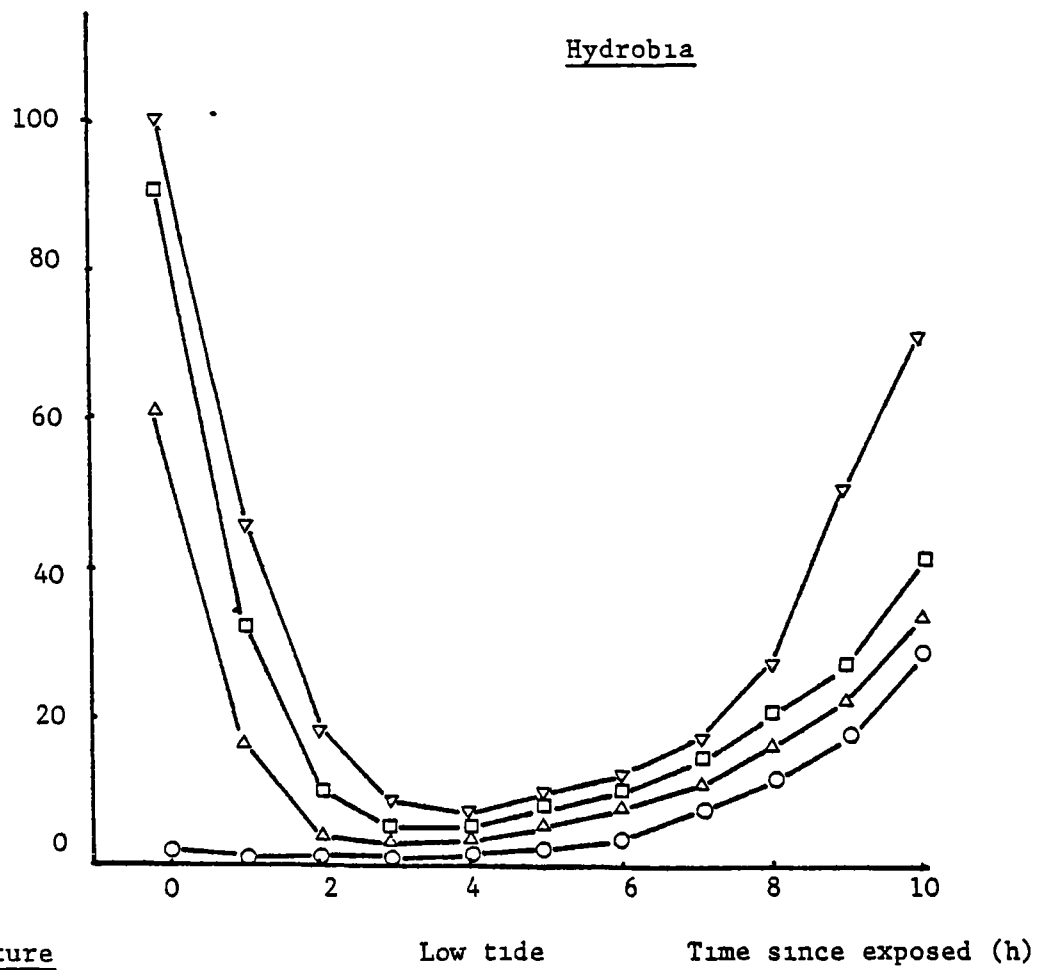

Air temperature

Low tide

Time since exposed (h)

▽ 15°C

□ 10°C

△ 5°C

○ 0°C

Fig 35

Predicted percentage of Hydrobia ulvae available, throughout the tidal cycle, at four air temperatures Available includes Hydrobia on the surface (see Fig 34) and those whose presence below the surface is revealed by burrow exit holes

tidal emersion also increased. Above about 13°C all the Hydrobia were at the surface when it was first exposed. The population rapidly burrowed over the next five hours, such that over the latter half of tidal exposure, less than 2% of the population was available at the mud surface across all temperatures

(ii) Surface cue availability

The total number of small burrows multiplied by the probability of an individual burrow containing a Hydrobia (section 3.8.1.1) as a proportion of the Hydrobia density increased significantly with the hours since tidal emersion and mud temperature, decreased significantly with Hydrobia density, and was independent of air temperature. All the significant relationships were non-linear except that with density (Table 11).

Substituting predictions of mud temperature, and assuming a mean density of 1747 m⁻² (mean density across all quadrats observed) the proportion of Hydrobia available as a result of surface cues over the tidal cycle at four air temperatures (0,5,10, and 15°C) was predicted, from the above equation (Table 11).

Combining these predictions with the proportion of the population at the surface (Fig. 34) a prediction of total availability over the tidal cycle was made (Fig. 35). Total availability declined rapidly after tidal exposure, but slowly recovered over the second half of the cycle to a lower level. Comparison of Fig. 34 and 35 shows this recovery was entirely a result of burrowing Hydrobia leaving surface cues.

(b) Corophium volutator

(i) Surface availability

Burrow emergence lasted on average 2.28s ($\sigma = 0.712$, $n = 44$).

Surface availability, the percentage time spent at the surface by one

Percentage available as a result of surface cues

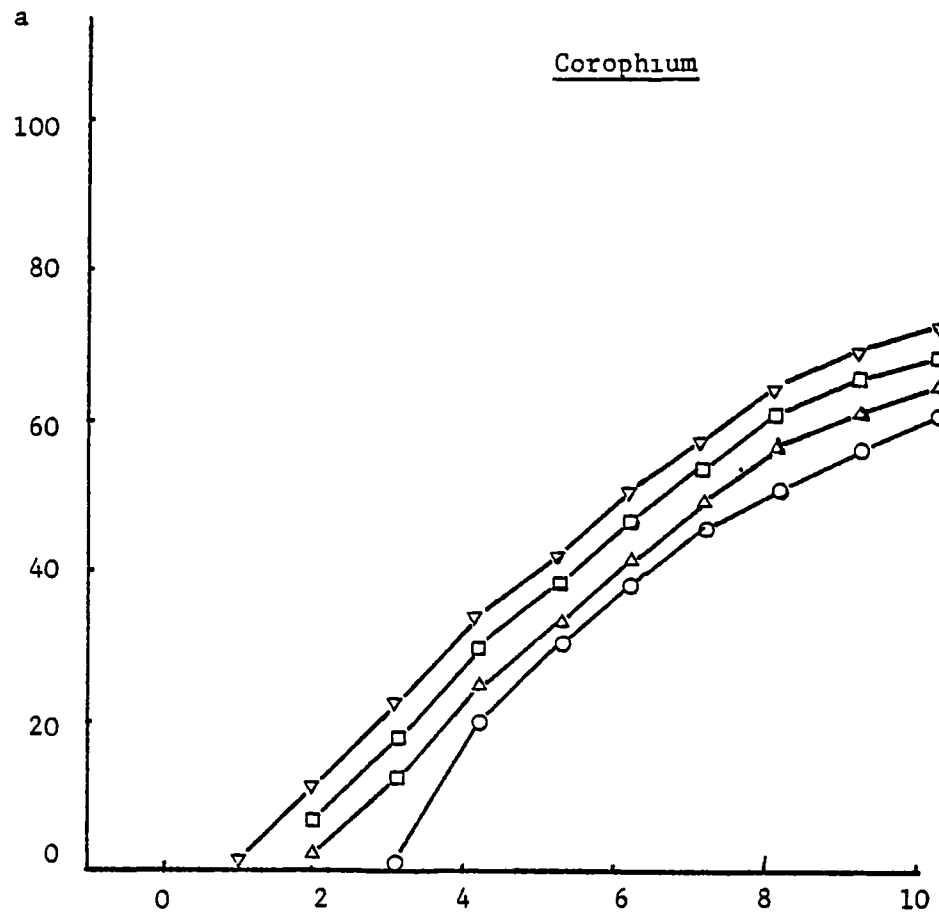

Air temperature

- ▽ 15°C
- 10°C
- △ 5°C
- 0°C

Low tide

Time since exposed (h)

Fig 36

Predicted percentage of Corophium volutator available, throughout the tidal cycle, at four air temperatures Available includes only those available because surface cues (burrow exit holes) revealed their presence below the surface

individual, increased significantly with increasing mud temperature, decreased significantly with increasing air temperature and hours since tidal emersion, and was independent of Corophium density. All the significant relationships were non-linear (Table 11). Surface availability never exceeded 0.5% across all conditions.

(ii) Surface cue availability

The total number of small burrows, multiplied by the probability of an individual burrow containing a Corophium (section 3.8.1.1) and expressed as a proportion of the Corophium density, increased significantly with increasing mud temperature and hours exposed and decreased significantly with increasing air temperature and Corophium density. All the relationships were non-linear except that with density (Table 11).

Substituting predicted mud temperatures and assuming a mean density of 800 m^{-2} , predictions were generated of the proportion of Corophium available as a result of surface cues throughout the tidal cycle at four air temperatures (0, 5, 10 and 15°C) (Fig. 36).

Surface cue availability was very low at tidal emersion and increased throughout the period of exposure. Increases were greater at higher temperatures. At the end of the tidal cycle over 80% of Corophium at 15°C and over 60% at 0°C were available. As surface availabilities never exceeded 0.5% (above) the pattern of total availability was almost identical.

The total number of surface burrows (both Corophium and Hydrobia) and mud surface water content (% wet mass) are plotted against tidal exposure at 5°C in Fig. 37. Burrows started to appear approximately two hours after tidal emersion when the surface water content was 55 to 60%.

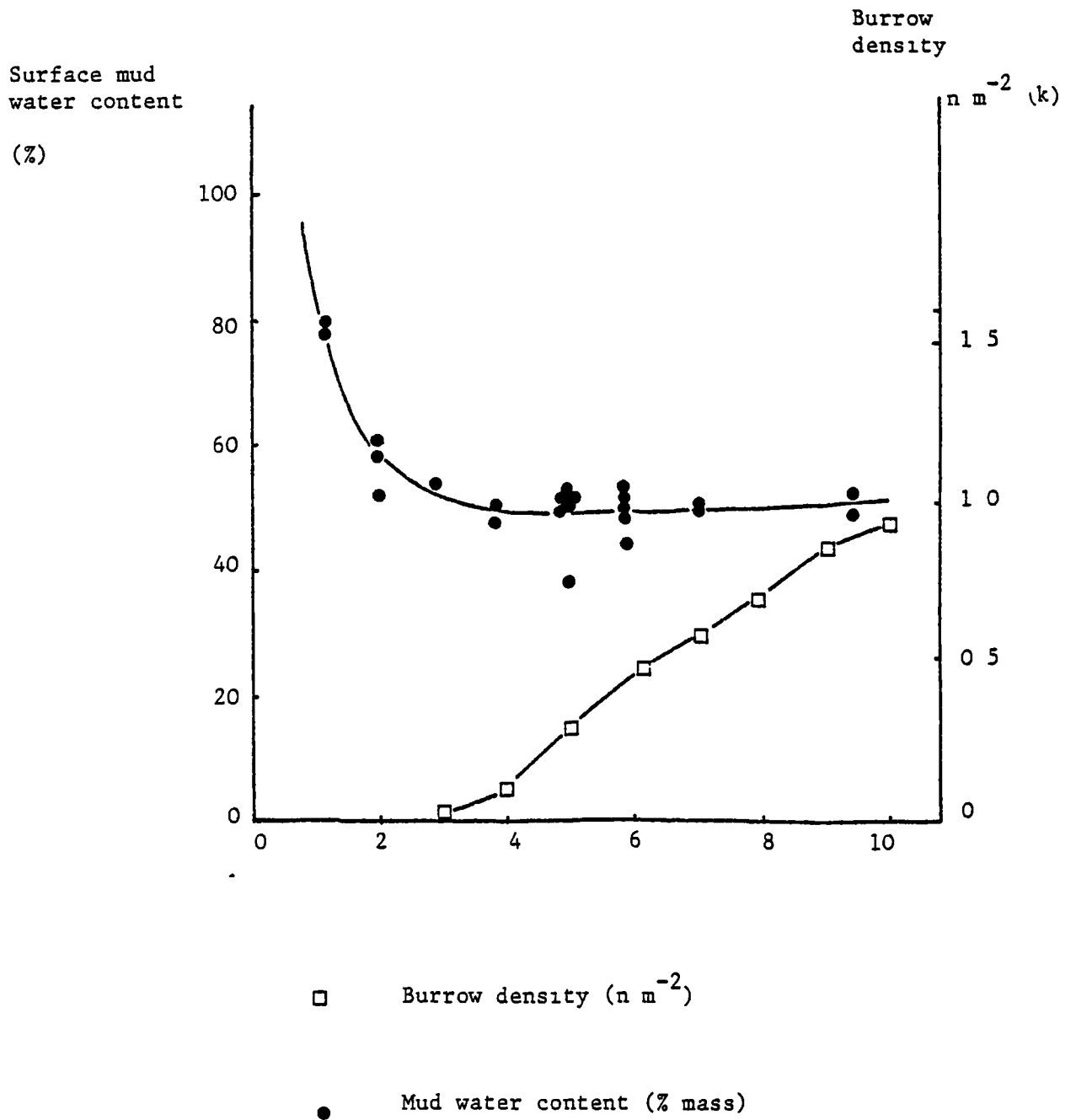

Fig 37 The density of small burrows (*Hydrobia* and *Corophium*) ($n m^{-2}$) and the mud surface water content against time since tidal emersion, at $5^{\circ}C$. Burrows did not appear until after approximately two to three hours when the surface mud water content was between 55 and 60% (Curves fitted by eye)

(c) Macoma balthica(1) Surface availability

The percentage of Macoma with active siphons significantly increased with increasing mud temperature and Macoma density, and significantly decreased with increases in air temperature and hours exposed. All the effects were linear (Table 11). Substituting predicted mud temperatures and a Macoma density of 297 m^{-2} (mean winter density across all plots), predictions were generated of the percentage of Macoma with active siphons against tidal exposure at four air temperatures (0,5,10 and 15°C) (Fig. 38).

Siphon activity was greatest at tidal exposure (= 6.5%) and decreased throughout the exposed period until after approximately seven hours none were active. Differences between temperatures were relatively small. Because individual siphons are active for long periods, percentage siphon activity reflects percentage availability.

(d) Nereis diversicolor

Burrow emergence in Nereis lasted on average 15.8s. ($\sigma = 12.9$, $n = 32$). The percentage time spent exposed at the surface by any one individual was always less than 5%. Surface availability increased linearly with increasing air temperature, and was independent of mud temperature, hours exposed and Nereis density.

(3.8.1.1) Surface cues - reliability of identification(a) Small Burrows

The contents of 31 cores (1 cm diameter) collected around small burrows believed to contain either Hydrobia or Corophium, and 16 identical cores randomized on a featureless mud surface are summarized in Table 12. Over 64% of small burrows contained prey, 80% of which were Corophium. In contrast, 94% of cores collected on the featureless flat

Percentage with active siphons

(%)

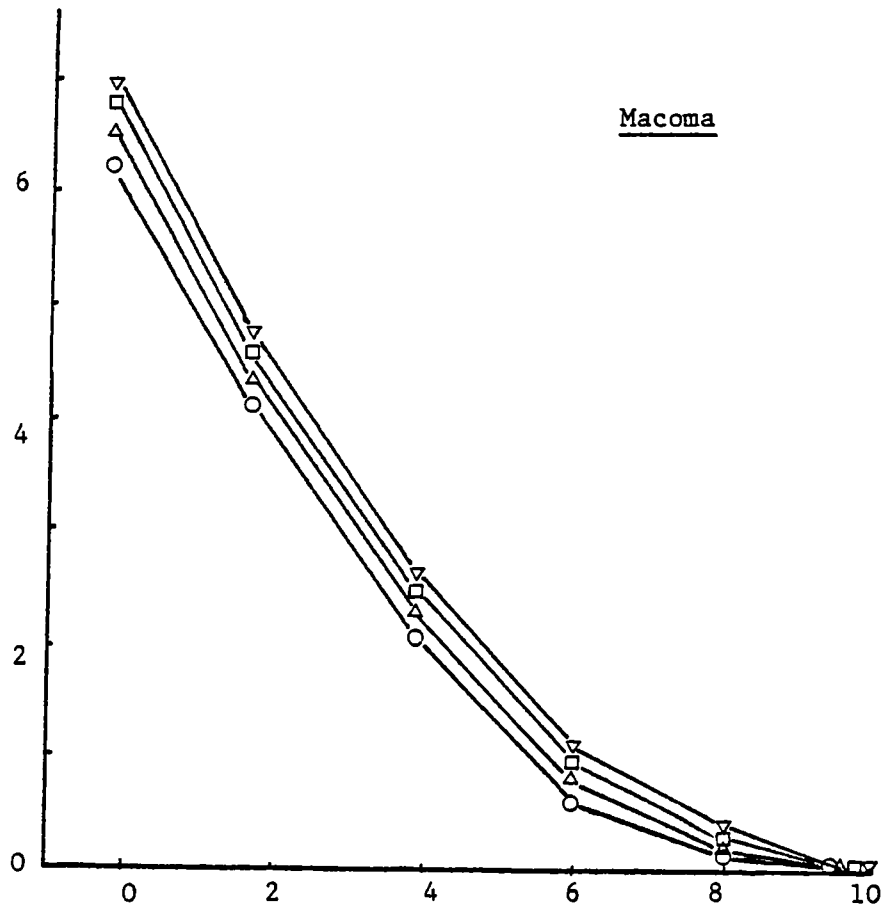

Macoma

Low tide

Time since exposed (h)

Air temperatures

▽ 15°C

□ 10°C

△ 5°C

○ 0°C

Fig 38 Predicted percentage of Macoma balthica with active siphons, throughout the tidal cycle, at four air temperatures

Table 12

The contents of small (1 cm diameter) cores collected over surface cues (burrows) and at random on the featureless mud surface.

Small burrows (1 cm diameter cores)

| | <u>Hydrobia</u> | <u>Corophium</u> | <u>Macoma</u> | <u>Empty</u> |
|-------------|-----------------|------------------|---------------|--------------|
| 'Burrows' n | 5 | 15 | 0 | 11 |
| % | 16.12 | 48.38 | 0 | 35.5 |
| 'Random' n | 0 | 1 | 0 | 15 |
| % | 0 | 6.25 | 0 | 93.75 |

were empty.

(3.8.2) Tactile foraging Redshank

(a) Hydrobia ulvae

(i) Total Density

There was a significant effect of core depth on the estimated density of Hydrobia ($F = 12.46$, $p < .001$, $df(1) = 2$, $(2) = 96$). The difference between the estimated densities to 1 cm and 2 cm depths was not significant ($t = -0.74$, $p = 0.47$) but estimated densities to both 1cm. and 2cm. depths were significantly different from the estimated density to 6cm. (1-6 cm $t = -4.2$, $p < .0001$, 2 - 6 cm $t = -3.51$, $p < .001$). On average, 53.1% of the population in the top 6 cm was present in the top 1cm. of the substrate, and 57.9% in the top 2 cm.

(ii) Size distributions

Size distributions of Hydrobia from each depth are shown in Fig. 39. Differences between depths were not significant.

(b) Corophium volutator

There was a significant effect of core depth on the estimated density of Corophium volutator ($F = 3.95$, $p < .05$ $df(1) = 2$, $(2) = 96$). The differences between estimated densities to 1 and 2 cm and between estimated densities to 2 and 6 cm depths were not significant. However, the difference between the estimated densities at 1 and 6 cm depths were significant ($t = -2.67$, $p < .01$). On average, 48.1% of the population in the top 6 cm was present in the top 1 cm and 71.8% in the top 2 cm. Insufficient numbers of Corophium were collected to allow a detailed comparison of size distributions with depth, although no obvious trend was apparent.

(c) Macoma balthica

The results of an analysis of variance, comparing densities across

Hydrobia

Density
to 1 cm
(n m⁻²)

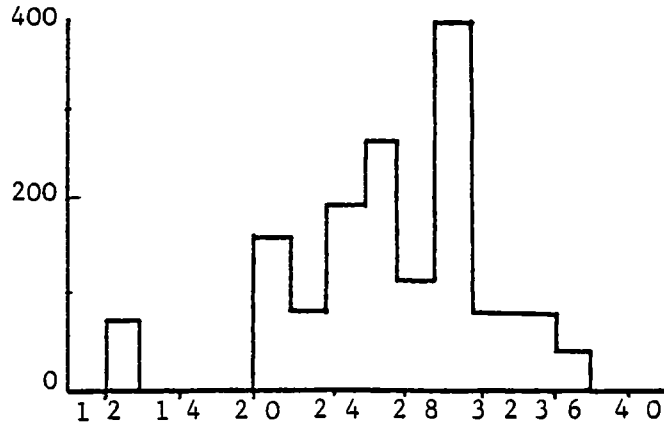

Depth of core
1 cm

Shell length (mm)

Density
to 2 cm
n m⁻²

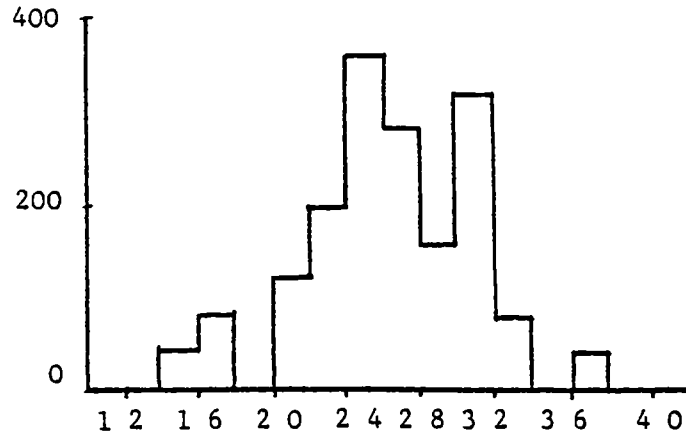

2 cm

Shell length (mm)

Density to
6cm
n m⁻²

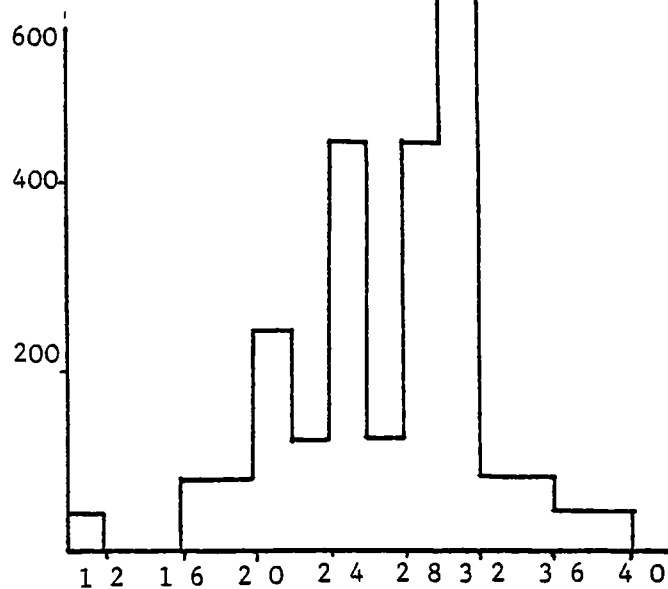

6 cm

Shell length (mm)

Fig 39

Size/density distributions of Hydrobia ulvae from cores taken to three different depths in the same plot at Skinflats, in Early Winter (n cores at each depth equals five)

three size classes and three depths are shown in Table 13. Both size and depth had significant effects on density, and there was a significant interaction between these variables. Analysis of the cell means suggests that in total only 5.6% of Macoma in the top 6 cm. were present in the top 1 cm and 71.4% of these were small (0.26 - 0.75 cm). Expressed as a percentage of the density of its own class, the top 1 cm contained 10.6% of small Macoma (0.26 - 0.75 cm), 2.8% of medium Macoma (0.75 - 1.25 cm) and no large Macoma (>1.26 cm).

(3.8.3) Oystercatcher

The percentage of mussels in each 5 mm shell length class which were totally concealed by other mussels in the clump increased rapidly as shell length decreased below 2.5 cm (Fig. 40). All mussels greater than 2.5 cm long had some part of the surface exposed.

(3.9) Foraging path width

(a) Direct estimates

Estimates of foraging path width to each side of the foraging path centre are shown in Table 14. The direct estimate of tactile foraging path width in Redshank was 56% greater than the visual foraging path width. Visual searching Oystercatchers could reach approximately 50% further than visual searching Redshank.

(b) Indirect estimates

The relationship between mean Hydrobia density and distance to one side of fresh search path is shown in Fig. 41. Each point represents data from a separate tide at that distance. The fitted curvilinear regression explained 41% of the variability in mean Hydrobia density.

Table 13

Results of a two-way analysis of variance, with density of Macoma balthica as the dependent variable and size of Macoma (body width) and depth of the sampling core as the independent variables

Analysis of variance

| (df) | Independent variable | SS | MS | F | P |
|------|----------------------|--------|-------|-------|------|
| 2 | Size | 19.68 | 9.82 | 22.47 | .001 |
| 2 | Depth | 26.11 | 13.05 | 29.8 | .001 |
| 4 | Interaction | 14.43 | 3.69 | 8.23 | .001 |
| 288 | Residual | 126.0 | 0.438 | | |
| 290 | Total | 186.22 | | | |

Cell Means (n = 33 for all cells) - (n m⁻²)

| Depth size | | 1 cm | 2 cm | 6 cm |
|------------|---|--------|--------|-------|
| Small | x | 60.6 | 303.04 | 278.8 |
| | | 145.64 | 374.56 | 338.9 |
| Medium | x | 24.24 | 290.92 | 533.2 |
| | | 96.92 | 320.52 | 486.4 |
| Large | x | - | - | 12.12 |
| | | - | - | 69.6 |

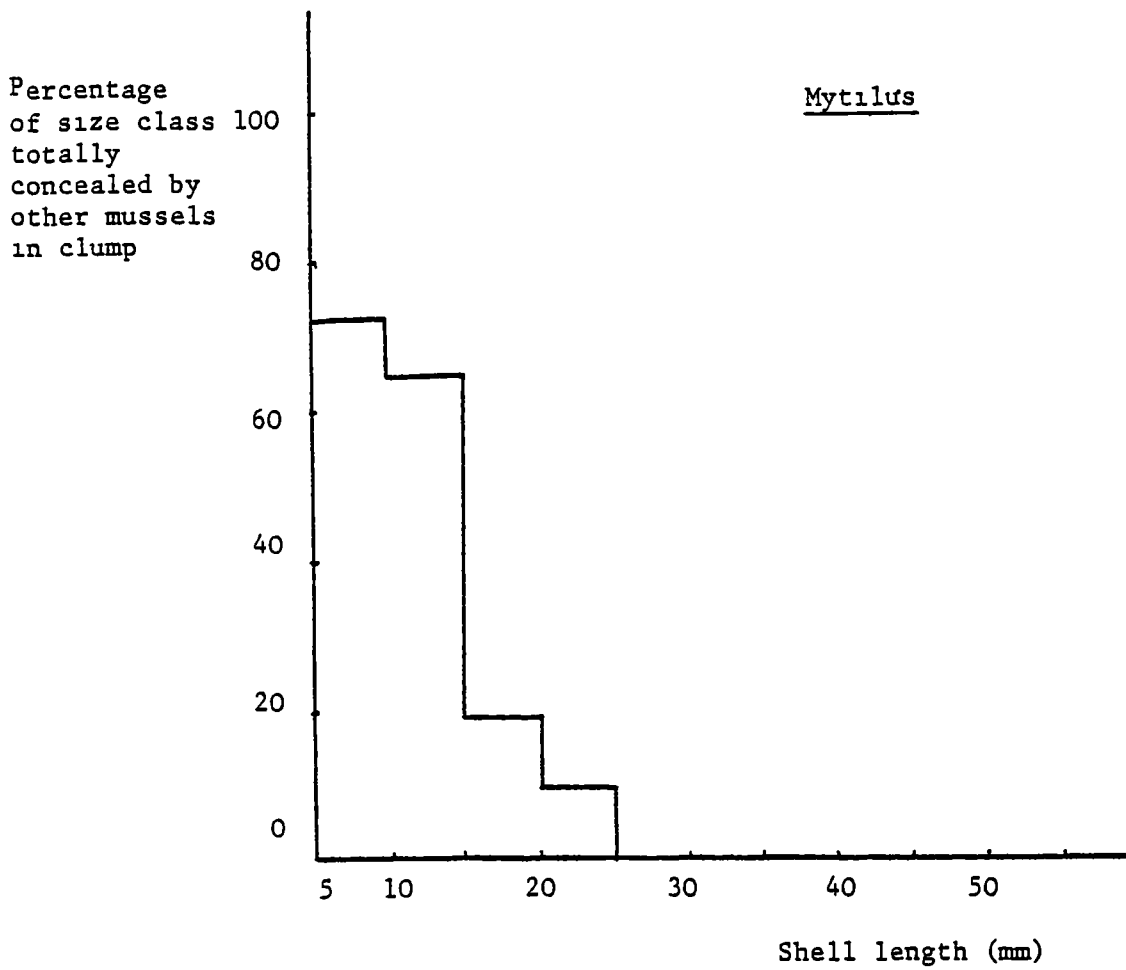

Fig 40 The percentage of mussels in a given size class which are totally concealed by other mussels in the clump Assessed by spray painting the mussel clumps in situ and breaking up the clump to find mussels with no paint coverage

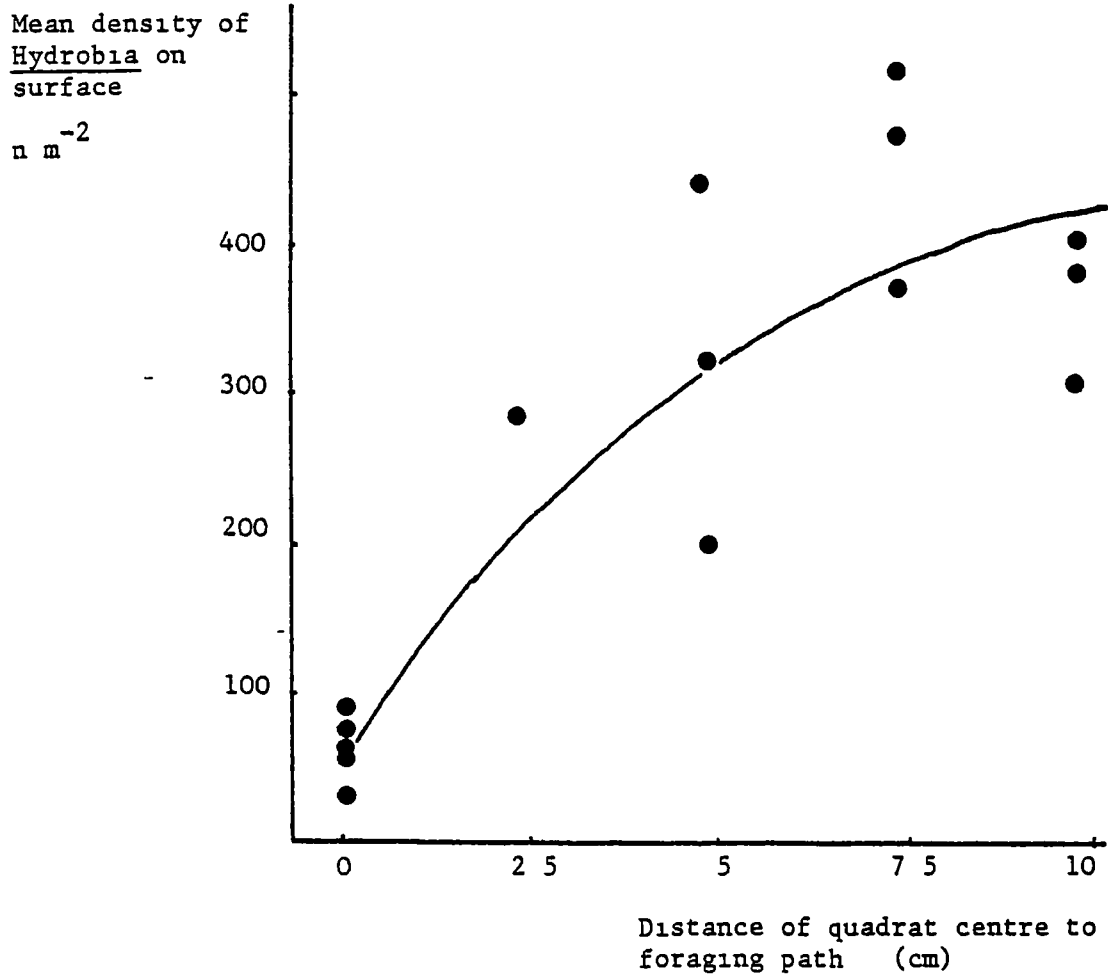

Fig 41 Surface densities of Hydrobia ulvae at different distances from the centre of fresh Redshank foraging paths. Each point represents the mean density at that distance, on an independent tide, calculated across between 60 and 336, 5 cm x 5 cm quadrats. (total n quadrats = 1294). The curve describes the fitted regression equation

$$y(n\ m^{-2}) = 56.7 + 50 \log_e x (+1) (cm)$$

$$r^2 = 41.0$$

$$n = 16$$

$$F = 56.52$$

$$p < .01$$

Although Redshank and Oystercatcher were capable of reaching upto the direct estimate of foraging path width (above), items further from the path centre were less likely to be ingested. It is assumed that the reason for this relationship is an inverse function between p_d (the probability of an item being detected) and distance from the path centre. The 'effective foraging path width' was defined as the path width equivalent to that observed if p_d equalled 1.0 and was independent of distance from the path centre.

The effective path width of the foraging path W_e was calculated as follows.

$$W_e = \frac{A_{sr}}{10^4} \quad (30)$$

W_e - effective width of the foraging path, to one side of the path centre, in mm.

A_{sr} - area subtended by the fitted regression curve to the y-axis for values for x from 0 to 100 mm, in mm^2 .

The 'effective foraging path width' of visual foraging Redshank equalled 23.4 mm, or 0.483x the direct estimate (above). The effective foraging path widths of tactile foraging Redshank, and Oystercatcher were presumed to equal the same proportion of the direct estimates of foraging path width.

Table 14

Direct estimates of d_v , θ_v , d_t and θ_t (see Fig 10) in visual and tactile searching Redshank and visual searching Oystercatcher, observed at close range in an aviary, with the maximum reach distance to one side of the path centre ($d \sin \theta$).

Redshank

| | | d_v (mm) | θ_v (°) | Maximum Reach dist. (mm) |
|----------------|---|------------|----------------|--------------------------|
| <u>Visual</u> | x | 76 0 | 40.2 | 48.4 |
| | | 8 0 | 4.6 | |
| | n | 44 | 26 | |
| | | d_t (mm) | θ_t (°) | MRD (mm) |
| <u>Tactile</u> | x | 9.7 | 51 3 | 75.7 |
| | | 0.7 | 4.2 | |
| | n | 36 | 12 | |

Oystercatcher

| | | d_r (mm) | θ_t (°) | MRD (mm) |
|---------------|---|------------|----------------|----------|
| <u>Visual</u> | x | 127 4 | 35 0 | 73.1 |
| | | 26 0 | 9 3 | |
| | n | 74 | 43 | |

(3.10) Prey Handling Time - Redshank(a) Visual searching

The estimated mean prey handling times for each prey class are shown in Table 15. Small items pecked from the mud surface were handled fastest. There was a non-linear relationship between body width and handling time in Macoma - the fitted regression equation \log_e handling time = $2.16 + 1.14 x(\text{cm})$ explained 84.6% of the variability in \log_e handling time.

Assuming all the variability in the handling time of the smallest class to be a result of differences in the burrow depth of the prey, a function relating handling time to depth was generated by comparing the distribution of handling times to the prey depth distribution (section 3.8.2.c). The relationship found was: handling time(s) = $-0.075 + 0.75 d$ (cm) where d = prey depth. Using this function, predictions were generated from the depth distributions of medium and large Macoma of expected handling times if handling was independent of prey size. The mean predicted handling times were 2.08s for medium (0.26 - 0.75 cm) Macoma and 3.68 s for large (> 1.26 cm) Macoma.

The observed mean handling time for medium sized Macoma was not significantly different from that predicted from the depth distribution. Observed handling times for large Macoma were significantly greater than that predicted from the depth distribution.

Handling times for Nereis increased linearly with prey body length. The linear regression equation, handling time (s) = $0.0924 + 0.427 \text{ length (cm)}$ explained 76.4% of the variability in handling time ($F = 375.7, p < .001$)

(b) Tactile searching

Tactile searching Redshank were only ever seen to select small

Table 15

Estimates of prey handling times for visual searching Redshank feeding on all prey types, in the field.

| <u>Species/ Type</u> | <u>Size</u> | <u>Mean Handling time (s)</u> | <u>σ</u> | <u>n</u> |
|--------------------------|------------------------------|---------------------------------------|----------------------------|----------|
| <u>Small Items</u> | | 0 416 | 0 14 | 180 |
| <u>Macoma</u> | Small (0.25 - 0.75 cm) | 1 00 | 0 21 | 116 |
| | Medium (0.76 - 1.25 cm) | 2.03 | 0 42 | 46 |
| | Large (> 1.26 cm) | 12 4 | 2.3 | 4 |
| <u>Worms</u> | Small (0 - 19 mm) | 0 995 | 0 249 | 82 |
| | Medium (20 - 35 mm) | 1 746 | 0.385 | 120 |
| | Medium/Large (35 - 51 mm) | 2.686 | 0.595 | 42 |
| | Large (51 - 68 mm) | 3 58 | 0 66 | 20 |

items. The mean prey handling time for these items was 0.36 s ($\sigma = 0.12$, $n = 40$) and was significantly ($t = 2.28$, $p < .01$) faster than the handling time when searching visually

(3.11) Oystercatcher

(a) Recognition time

The relationship between recognition time (s) and mussel shell length (cm), in 'prizing' Oystercatchers, was linear and positive (Fig. 42). The fitted regression equation Recognition time (s) = $-2.43s + 1.53 \times (\text{cm})$ explained 54.8% of the variability in Recognition time ($F = 165.3$, $p < .0001$, $df (1) = 1$, $(2) = 139$). Recognition time estimates for 'hammering' individuals were not significantly different, from the times predicted for 'prizers', at any mussel length. On average large (6 cm) mussels, were probed for three times longer than small (3 cm) mussels before manipulation. Recognition time, as a proportion of total handling time, was independent of mussel length and averaged 6.17% ($\sigma = 0.99\%$, $n = 141$) across all sizes.

(b) Manipulation time

In 'prizing' individuals manipulation time increased non-linearly with shell length (Fig. 43). The fitted regression equation $\log_e y = 2.13 + 0.388 \text{ length (cm)}$ explained 54.8% of the variability in \log_e handling time(s) ($F = 177.4$, $p < .0001$). Manipulation time estimates for hammering individuals were significantly lower at all mussel lengths. The fitted regression equation $\log_e y = 1.93 + 0.23 \text{ length (cm)}$ explained 52% of the variability in \log_e handling time. The two regressions had significantly different coefficients (analysis of covariance, $p < .001$).

On average prizing individuals took four times longer to open large

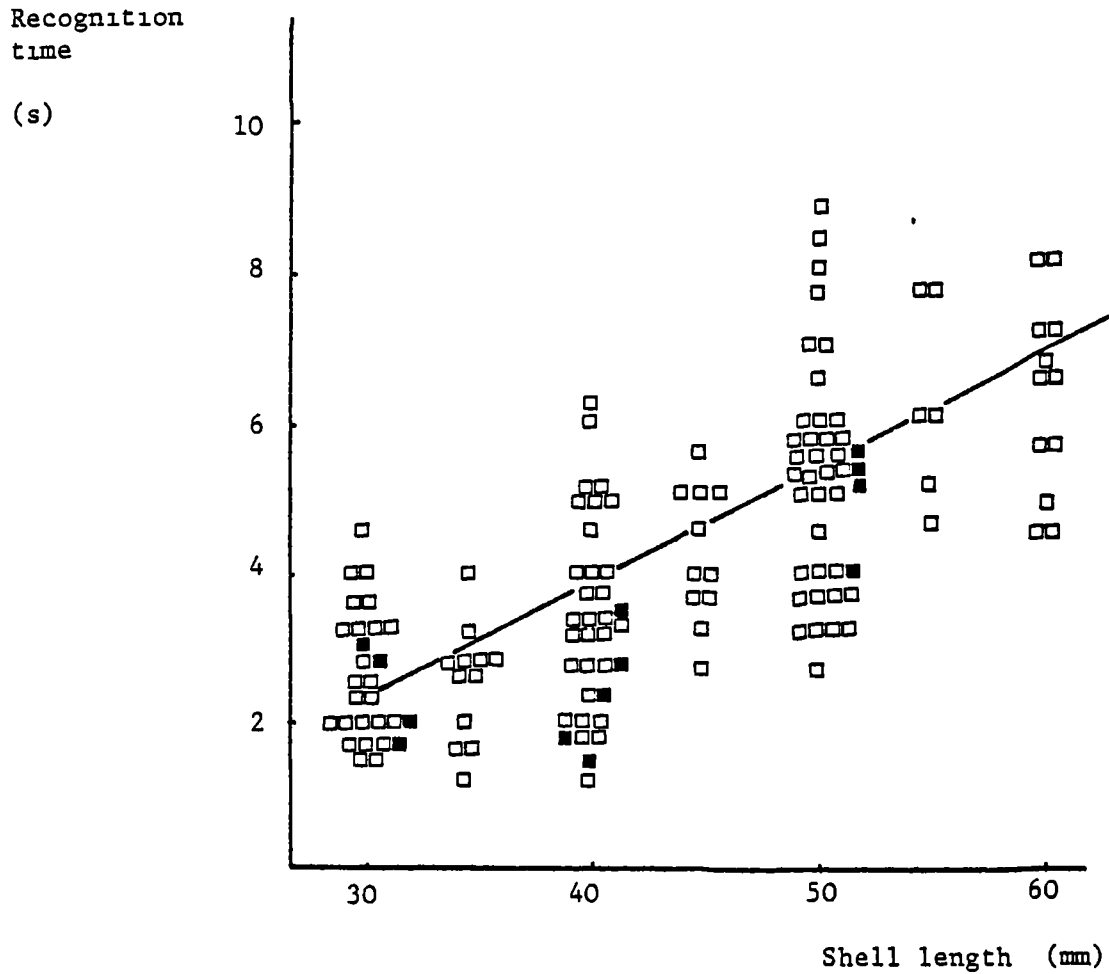

Fig 42 Time spent in recognition by Oystercatchers when successfully handling mussels, against mussel shell length Recognition equals from first probe to initiation of the attack Open symbols equal 'prizers' (n = 141), closed symbols equal 'hammerers' (n = 13) The curve describes the fitted regression equation ('prizers' only)

$$y (s) = -2.43 + 0.53 x (\text{mm})$$

$$r^2 = 0.547$$

$$F = 165.3$$

$$p < 0.01$$

Recognition times for 'hammerers' were not significantly different from times for 'prizers' at any shell length

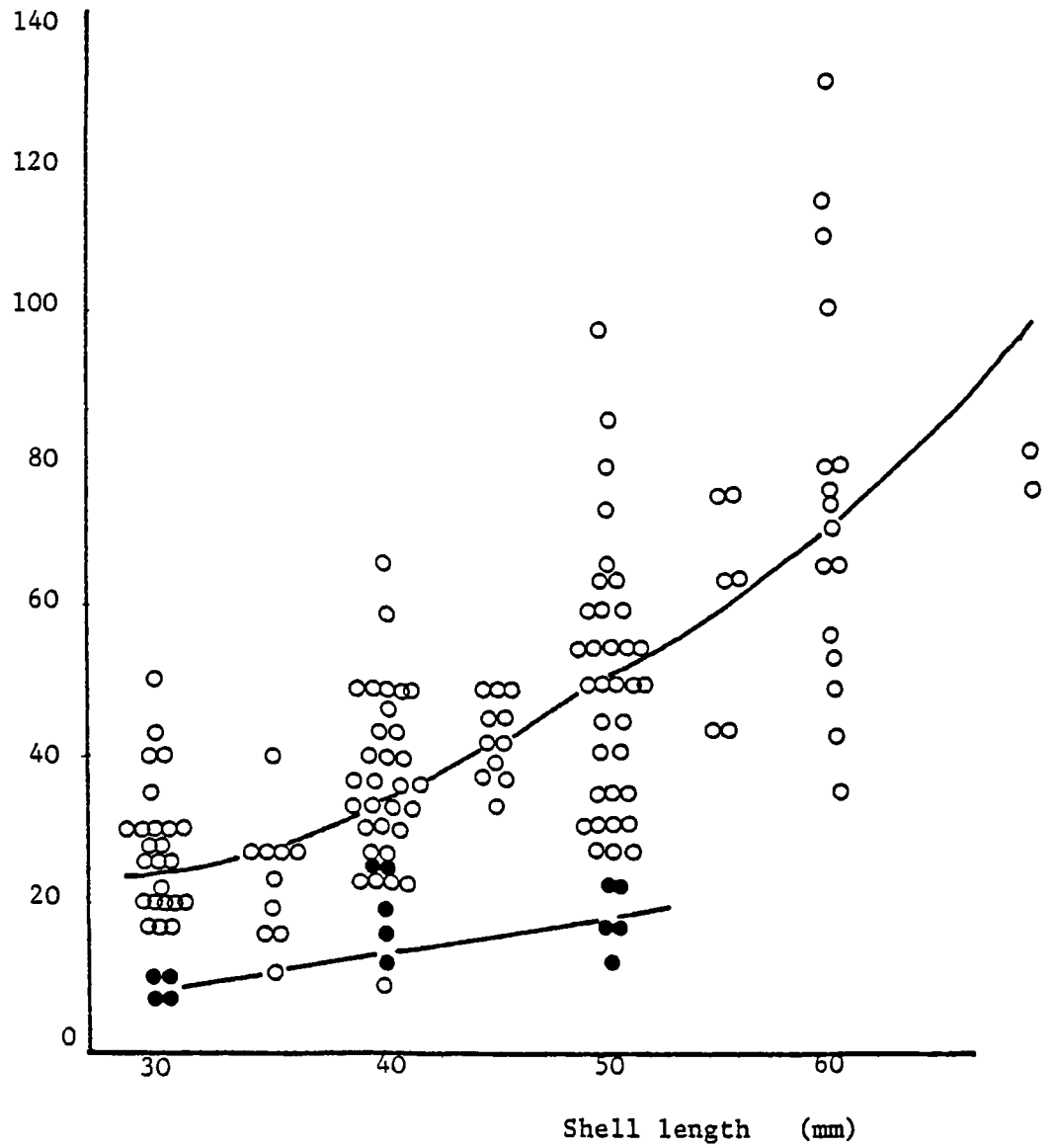

Fig 43

Time spent manipulating (hammering or prizing) mussels, by Oystercatchers, during successful attacks against mussel shell length. Open symbols equal 'prizers' (n = 141), closed symbols equal 'hammerers' (n = 13). Curves describe fitted regression equations

'prizers' $\log_e y (s) = 2.13 + 3.58 x (mm)$

'hammerers' $\log_e y (s) = 1.93 + 2.3 x (mm)$

'Hammerers' had significantly shorter manipulation times than 'prizers' at all shell lengths

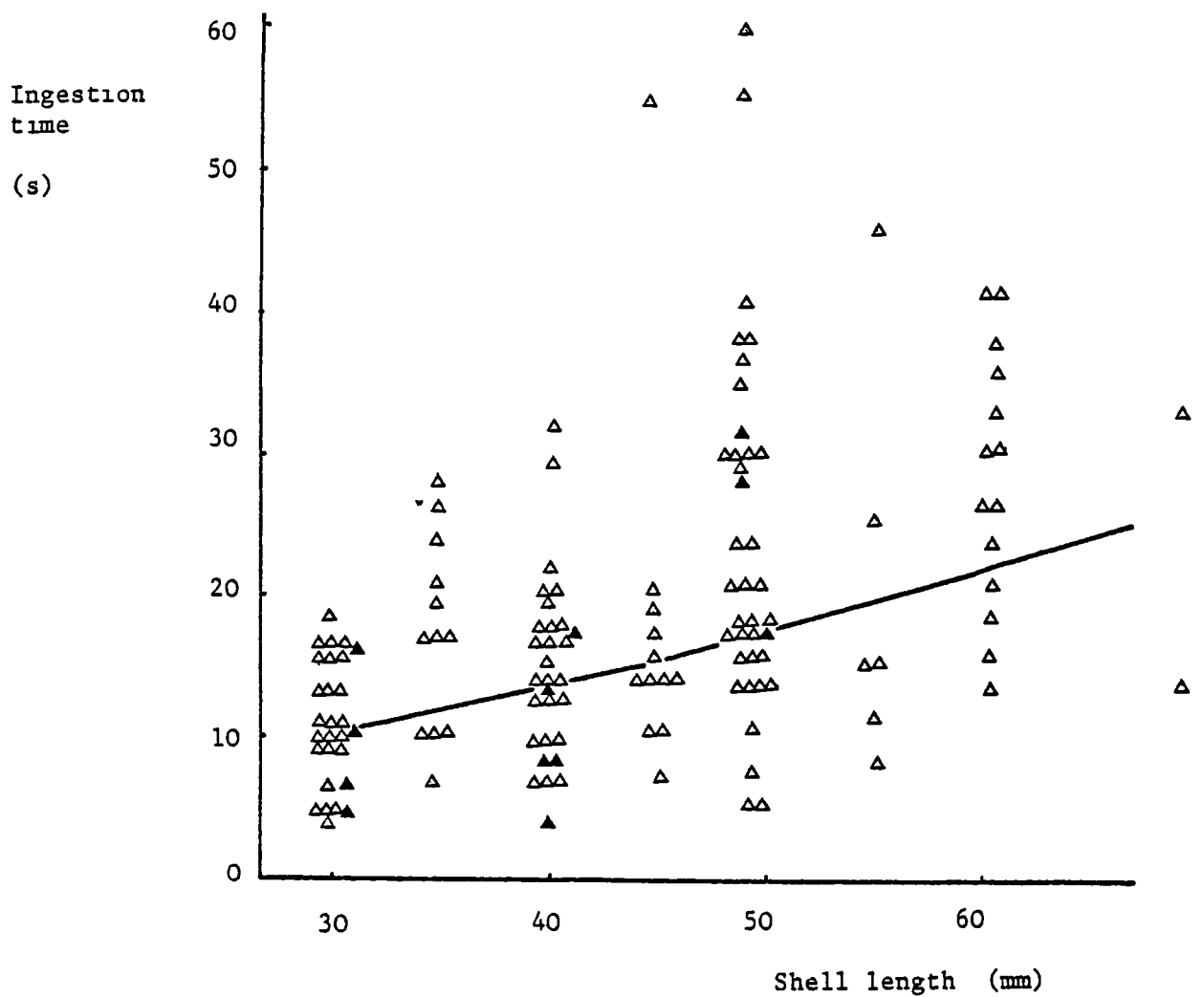

Fig 44 Time spent ingesting mussels, by Oystercatchers, during successful attacks against mussel shell length (mm) Open symbols equal 'prizers' (n = 141), closed symbols equal 'hammerers' (n = 13) The curve describes the fitted regression equation ('prizers' only)

$$\log_e y \text{ (s)} = 1.57 + 2.87 x \text{ (mm)}$$

$$r^2 = 25.7$$

$$F = 47.9$$

$$p < 0.1$$

Ingestion times for 'hammerers' were not significantly different from times for 'prizers' at any shell length

mussels (6 cm) than small mussels (3 cm). Hammering individuals were approximately 56% faster at opening mussels of a given size.

Manipulation time as a proportion of total handling time was independent of mussel length in prizing birds and averaged 65.16% of the total time ($\sigma = 10.53\%$). In hammering individuals the percentage of total time spent manipulating decreased with increasing mussel length. The fitted regression equation $y = 0.962 - 0.0969 \text{ length (cm)}$ explained 40.4% of the variability in % time spent manipulating ($F = 5.42, p < .05$).

(c) Ingestion time

Ingestion time increased non-linearly with mussel length (Fig. 44). The fitted regression equation explained 25.7% of the variability in y ($F = 94.0, p < .001$). Ingestion time estimates were not significantly different for hammering individuals at any mussel length. Large mussels (6 cm) took on average 2.5x longer to eat than small (3 cm) mussels despite containing over 15x the amount of flesh (section 3.4.1).

There was a significant positive relationship between ingestion time as a proportion of total handling time and mussel length in hammering individuals. The regression equation $y = 0.039 + 0.105 \text{ length (cm)}$ explained 40.4% of the variability in % time spent ingesting prey. The proportion of time spent ingesting prey was independent of mussel length in prizing individuals and averaged 28.7% ($\sigma = 11.5\%$) of the total time.

(d) Total prey handling time

Because all the components of handling time were positively related with length, and because the two largest components, manipulation and ingestion, were non-linearly related with length, there was a significant non-linear relationship between total handling time and mussel length (Fig. 45) in both prizers and hammerers.

In prizers the fitted regression $\log_e \text{ total time} = 2.66 + 0.33$

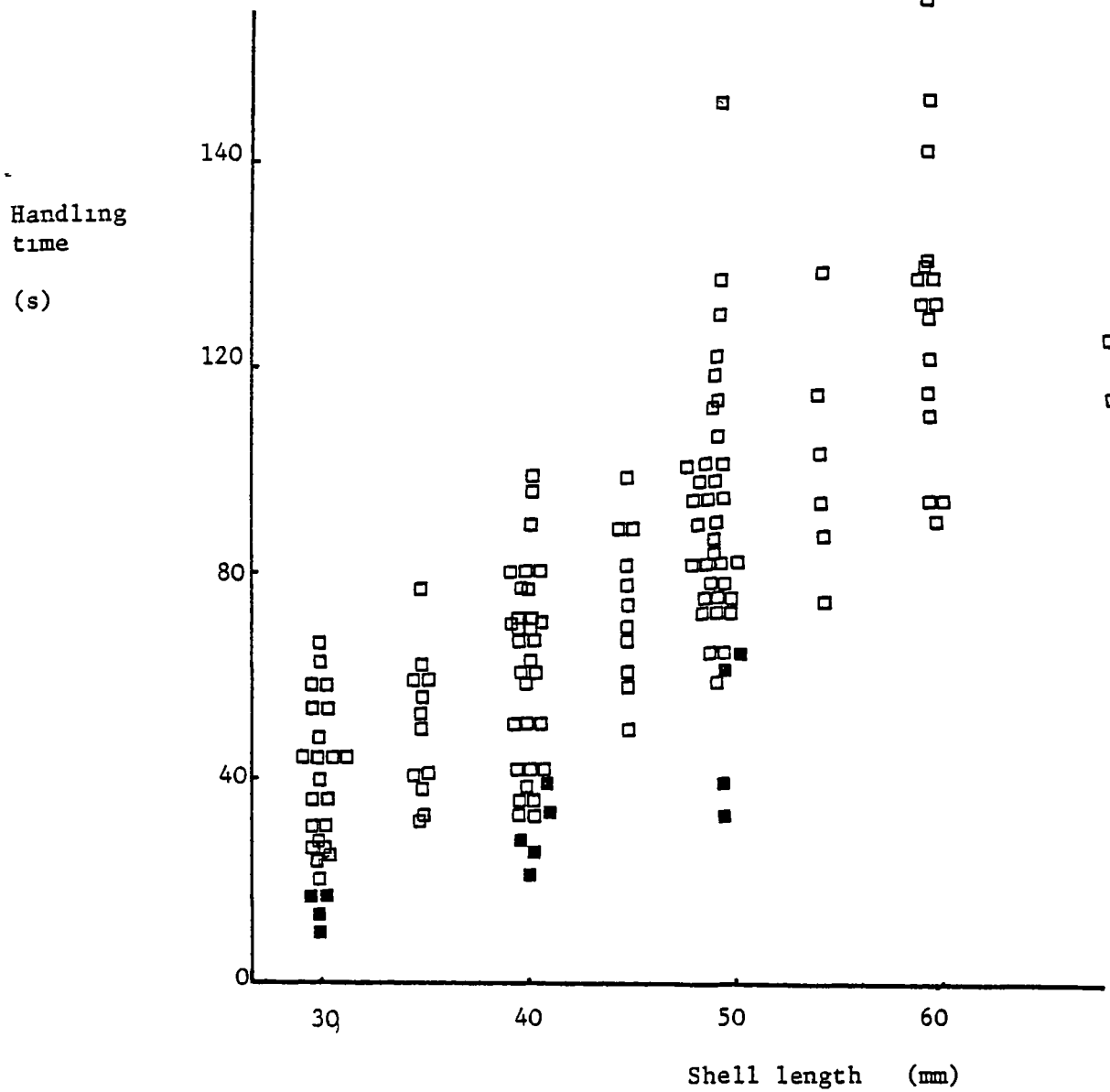

Fig 45 Time spent handling (recognizing, manipulating and ingesting) mussels, by Oystercatchers, during successful attacks, against mussel shell length (mm) Open symbols equal 'prizers' (n = 141), closed symbols equal 'hammerers' (n = 13). The curves describe fitted regression equations

'prizers' $\log_e y (s) = 2.66 + 3.3 x (mm)$

'hammerers' $\log_e y (s) = 1.79 + 4.08 x (mm)$

'Hammerers' had significantly shorter handling times than 'prizers' at all shell lengths

length (cm) explained 62.6% of the variability in total handling time whilst in hammerers the fitted regression \log_e total time = $1.79 + 0.408$ length (cm) explained 76.6% of the variability in y ($F = 31.1$, $p < .01$). The regressions had significantly different coefficients ($t = 2.54$, $p < .01$). On average, hammerers opened mussels 36% faster than prizers.

Times for the three components of handling were entered as the independent variables in a multiple regression analysis with total time as the dependent variable. The major variability in total handling time (83% in prizers, 64% in hammerers) was explained by variations in manipulation time.

Temperature, windspeed and plot location had no significant effects on handling times for mussels of a given size.

(3.12) Reliability tests of item identification

(a) Redshank

The percentage of Macoma classified as small medium and large, in a test to assess the reliability of observations (2.17.2) compared with their actual size is shown in Fig. 46. There was a slight tendency to underestimate size. Across all sizes 85% of classifications were correct. The classification of all prey types against their actual type is shown in Table 16. The difference between actual classifications and those expected at random was highly significant ($\chi^2 = 479.2$, $df = (36)$ $p < .0001$). However, the distribution did not differ significantly from the distribution expected if identification was perfect ($\chi^2 = 42.1$, $df = 36$, $p > .05$). On average, across all classes, misidentification occurred in 15% of cases. This over-estimates the actual misidentification, because in practice contrasting misidentifications

Table 16

Classifications of prey by an observer and their actual class, in a test to establish the reliability of diet observations. Prey were held in sight, in a pair of tweezers, by an assistant seated 100 m away, for 1 to 2 seconds, and observed using the same equipment as that used to observe Redshank in the field

Actual Class

| Classed as | Nothing | <u>Hydrobia</u> | Small | <u>Macoma</u> <u>Medium</u> | Large | <u>Carcinus</u> |
|---------------------|---------|-----------------|-------|--------------------------------|-------|-----------------|
| | 17 | 2 | | | | |
| Nothing | 77 | 27 | 4 | | | |
| | 3 | 38 | | | | |
| <u>Hydrobia</u> | 14 | 78 | | | | |
| | 2 | 9 | 31 | 2 | | |
| Small <u>Macoma</u> | 9 | 18 | 77 | 4 | | |
| Medium | | | 8 | 40 | 2 | |
| <u>Macoma</u> | | | 23 | 80 | 5 | |
| Large | | | | 8 | 38 | |
| <u>Macoma</u> | | | | 16 | 95 | |
| | | | | | | 9 |
| <u>Carcinus</u> | | | | | | 100 |

upper value = n

lower value = % of actual class

Percentage of
size class
classified as
Small, Medium
or Large

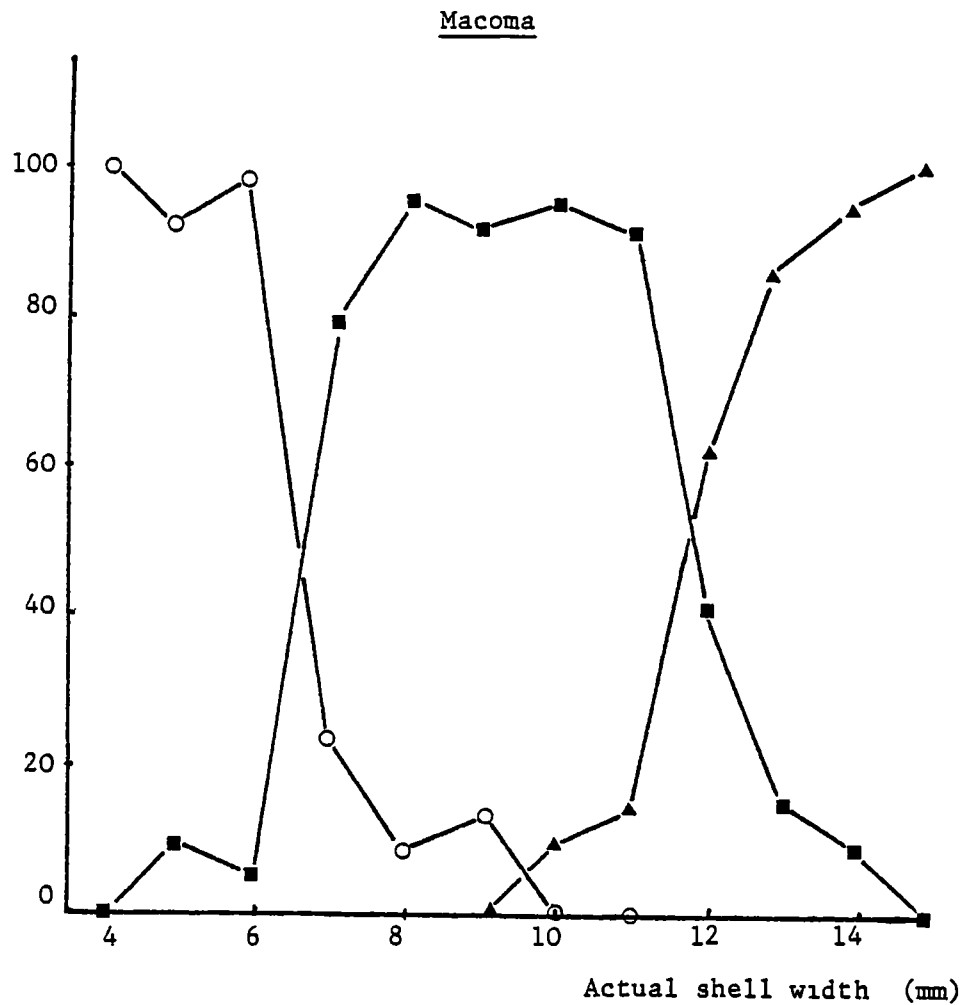

Classifications

- Small
- Medium
- ▲ Large

Fig 46 Percentage of Macoma classified as Small (2.6 to 7.5 mm), Medium (7.6 to 12.5 mm) and Large (>12.6 mm) against their actual size (nearest mm), in a test of establish reliability of size classifications

cancel out. Assuming equal encounter rates, net misidentification occurred in only 8% of the classifications.

(b) Correction of worm length for stretching

The percentage increase in length of relaxed worms stretched until they broke was greatest in small (10 mm) worms, which stretched almost 90% and lowest in large (60 mm) worms which stretched only 30% (Fig. 47)

The fitted regression equation, % increase = $100.1 - 1.133 \text{ length (mm)}$ explained 73.2% of the variability in % increase.

Estimates of worm size in the field were made during extraction, when worms were most visible. This was also the time worms were most stretched. Occasionally, worms broke during extraction which perhaps suggests they were normally stretched almost to breaking point. Assuming worms were stretched to 75% of their breaking point during extraction a regression was fitted, entering initial length as the dependent variable and length when at 75% of the total stretch, as the independent variable. The fitted equation $\text{Original length (cm)} = -5.36 + 0.815 \text{ length when 75\% stretched (cm)}$ was used to correct size estimates made in the field relative to the bird's bill length (see sections 2.5.7.1, 2.8.1, 3.1.4 and 3.10.1).

(c) Oystercatcher

Estimated and actual sizes of mussels are shown in Fig 48. There was a significant relationship between the estimated and actual sizes. The constant of the fitted regression equation was not significantly different from 0 ($t = 0.32, p > .05$) and the coefficient was not significantly different from 1.0 ($t = 0.14, p > .05$). The standard deviation of estimated values from a regression of estimated length on actual length was 38 mm. The probability of correctly placing an item within a 5 mm class was 0.48. The probability of correctly placing an

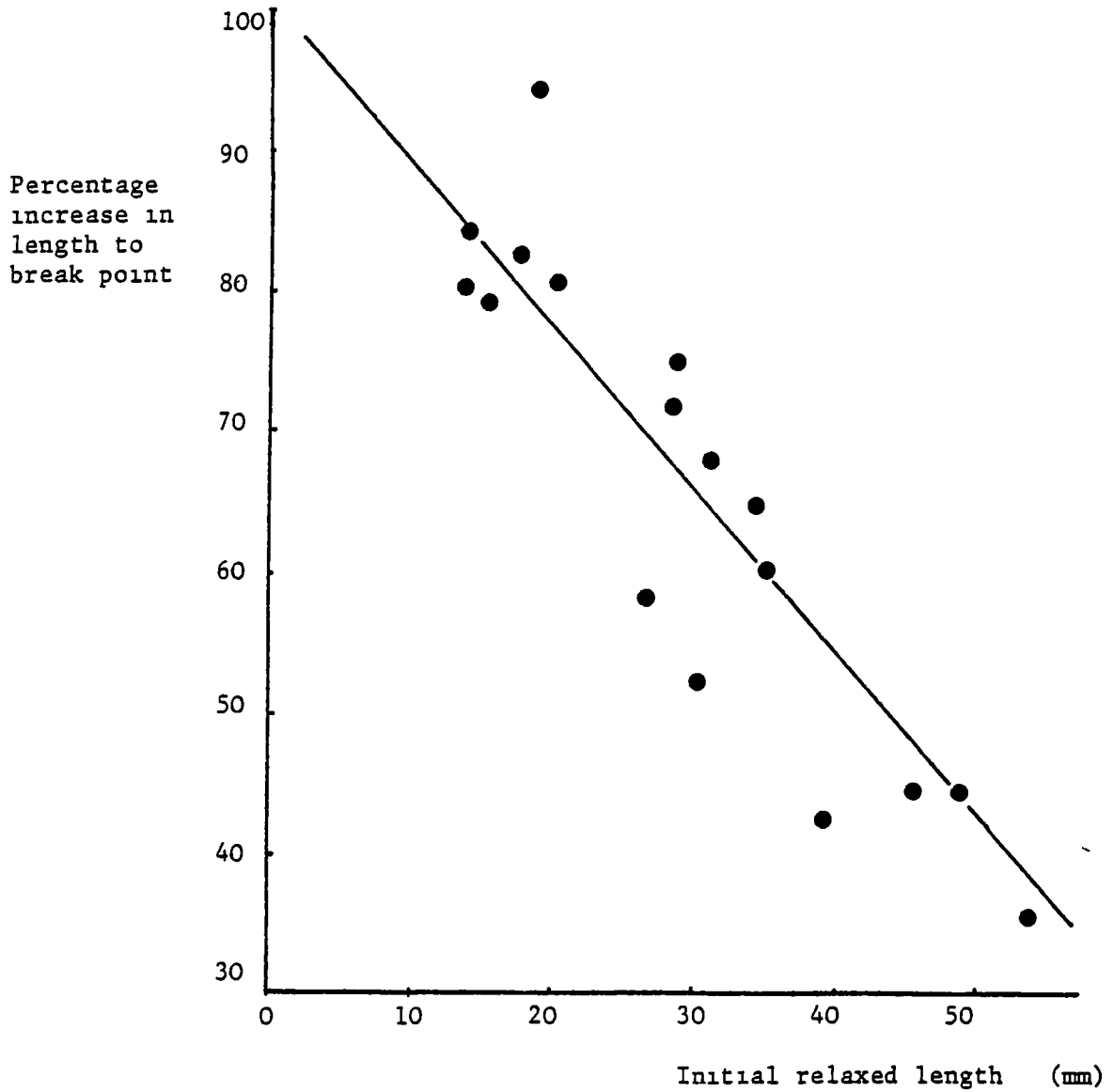

Fig 47 Percentage increase in initial length of relaxed worms, stretched until they broke, against length. The curve describes the fitted regression equation

$$y(\%) = 100 - 1.153 x (\text{mm})$$

$r^2 = 0.732$
 $F = 41.0$
 $p < 0.01$
 $n = 17$

Estimated
length
(mm)

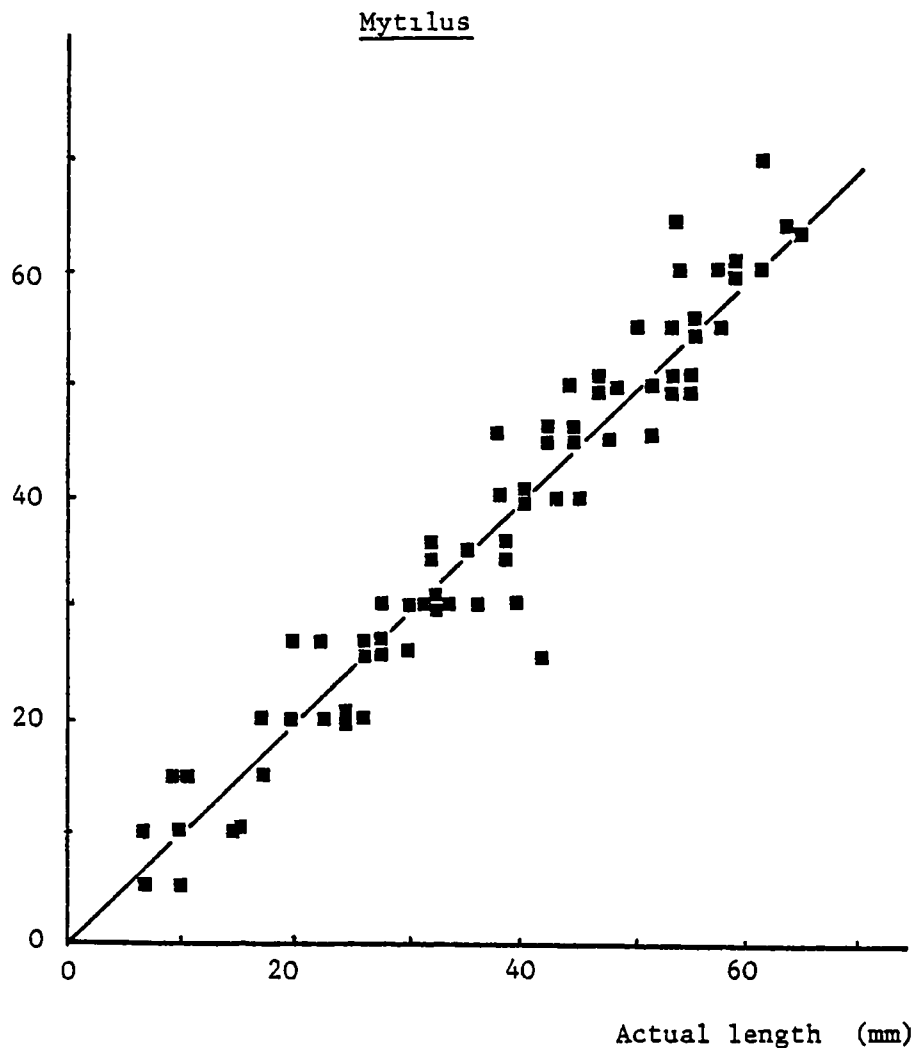

Fig 48

Estimated shell length of Mytilus against actual length in a test to assess reliability of field estimates of shell lengths
The curve describes the fitted regression equation

$$y = 0.146 + 0.996x \quad r^2 = 94.8\%$$
$$F = 1418.86$$
$$p < .001$$
$$n = 73$$

item within a 5 mm class or one of the immediately adjacent classes was 0.93.

(3.13) False recognitions, unsuccessful manipulations and kleptoparasitisms

(a) Redshank

(i) False recognition

The data were split between ebb tides (within three hours of tidal exposure), and flow tides (the remaining tidal period). Within each data set the number of false recognitions (= unsuccessful pecks) was entered as the dependent variable in a noconstant multiple regression analysis, with intake of small items and Macoma as independent variables (worms were selected too infrequently to include in the analysis) (Table 17).

On ebb tides Redshank made approximately one unsuccessful peck for each 22 successfully ingested small items and one unsuccessful peck per 4.5 Macoma ingested. Later in the tidal cycle the rate of unsuccessful pecking had increased in both prey, to one unsuccessful peck per 9 small items successfully ingested and 1.19 unsuccessful pecks per Macoma ingested.

(ii) Kleptoparasitism

A single interspecific kleptoparasitic interaction was observed when a Black headed gull (Larus ridibundus) stole a worm from a Redshank. A single intraspecific kleptoparasitism was observed in respect of a worm. Worms were kleptoparasised at a rate of one kleptoparasitic loss (both intra and interspecific losses) per 478 worms ingested. No kleptoparasitism was observed in respect of other prey.

Table 17

Rates of false recognition, unsuccessful manipulation and kleptoparasitisms in both prizing and hammering Oystercatchers, with the durations of these events.

| | n | False Recognition | Kleptoparasitism | | | | Total |
|---------------------------------|---|-------------------|---------------------------|-------|-------|--------------------|-------|
| | | | Unsuccessful Manipulation | Inter | Intra | Successful Attacks | |
| <u>'Prizers'</u> | | | | | | | |
| | n | 1905 | 204 | 3 | 0 | 85 | 2197 |
| | % | 86.71 | 9.28 | 0.136 | 0 | 3.86 | 100 |
| Rate rel. to successful attacks | | 22.41 | 2.4 | 0.035 | 0 | 1 | 25.84 |
| Duration \bar{x} (s) | | 1.893 | 14.93 | 26.42 | - | - | - |
| (σ) | | 1.63 | 9.27 | 8.43 | - | - | - |
| n | | 6.73 | 96 | 3 | - | - | - |
| <u>'Hammerers'</u> | | | | | | | |
| | n | 230 | 38 | 0 | 0 | 15 | 283 |
| | % | 81.27 | 13.24 | 0 | 0 | 5.3 | 100 |
| Rate rel. to successful attacks | | 15.33 | 2.53 | 0 | 0 | 1 | 18.76 |
| Duration \bar{x} (s) | | 2.01 | 9.09 | - | - | - | - |
| (σ) | | 1.60 | 3.78 | - | - | - | - |
| n | | 106 | 25 | - | - | - | - |

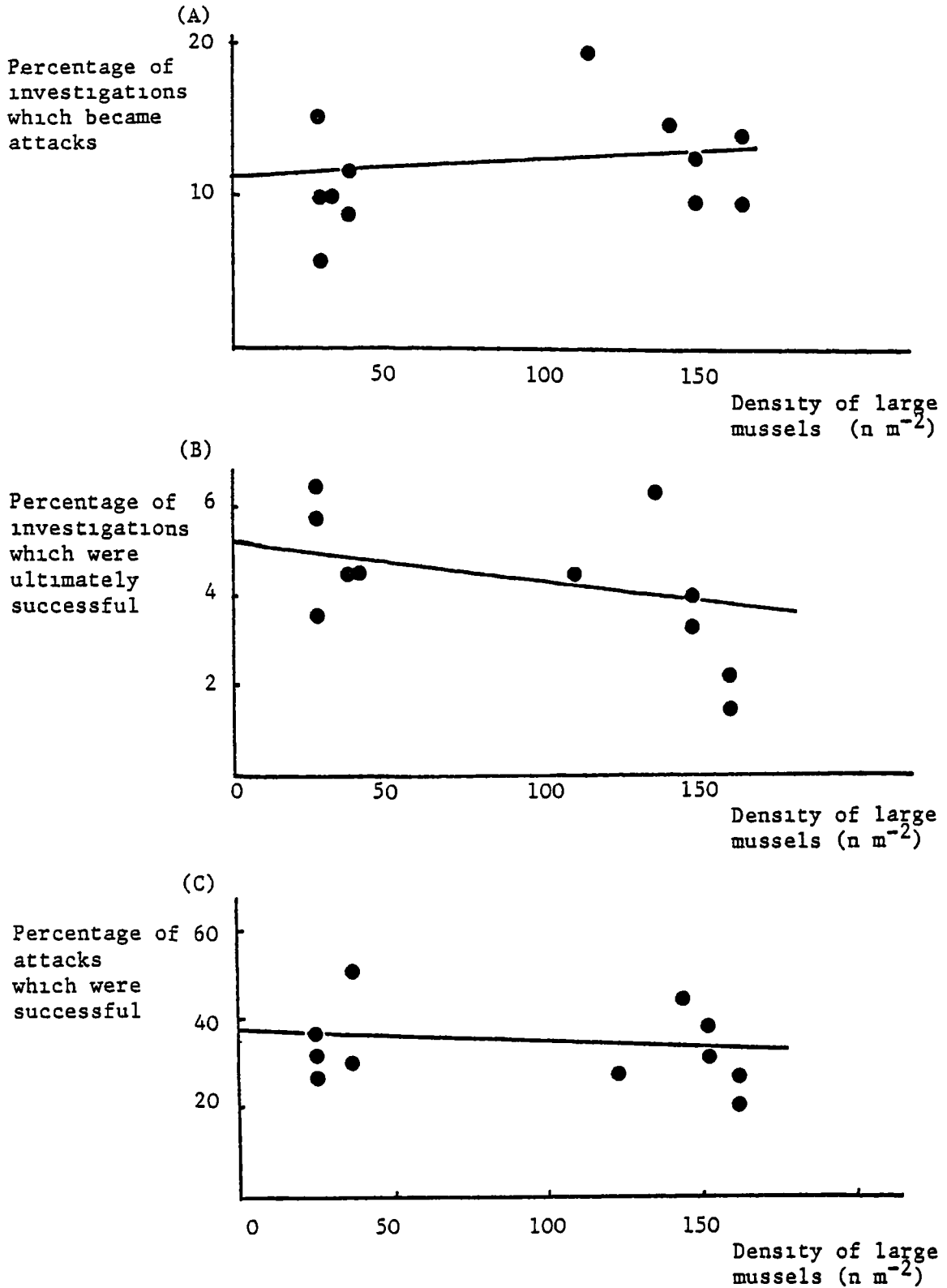

Fig 49 The percentage of investigations which became attacks (A) and were ultimately successful (B), and the percentage of attacks which were successful (C) against the density of large (>60 mm) mussels. The curves show the fitted regression lines. In all cases the gradients of the lines were not significantly different from zero ($p > 0.05$).

(b) Oystercatcher

The total rates of false recognitions (= probing terminated before manipulation started), unsuccessful manipulations (= attacks which yield no energy gain), kleptoparasitisms and successful attacks, across all sites, with the rates relative to successful attacks and the mean duration of these events are shown in Table 18 for both prizing and hammering Oystercatchers

In prizing Oystercatchers, the number of prey investigations which resulted in attacks, the percentage of investigations which resulted in successful attacks, and the percentage of attacks which were successful, were all independent of the density of large mussels (> 6 cm long) (Fig. 49 a-c).

On average, across all plots, prizing birds made 22.4 unsuccessful probes (= false recognition) and 2.4 unsuccessful manipulations for each mussel successfully ingested. The numbers of false recognitions and unsuccessful manipulations, in 'hammerers', per successful attack were 15.33 and 2.53 respectively. The distribution of events was significantly different between 'prizers' and 'hammerers' ($\chi^2 = 6.54$, $p < 0.01$, $df = 2$).

False recognition times and unsuccessful manipulation times were not significantly different across plots in 'prizers'. Duration of false recognition was not significantly different between prizers and hammerers ($t = 0.12$, $p > .05$). Unsuccessful manipulations were significantly shorter in hammerers ($t = 29.4$, $p < .0001$).

Carrion crows accounted for all three cases of interspecific kleptoparasitism. Intraspecific kleptoparasitism was never observed to be successful, although attempts to kleptoparasitise were noted. In addition to the time spent actually opening and ingesting a prey item,

'prizers' spent approximately 42.4 s in false recognition, 35.8 s in unsuccessful manipulation and 0.92 s handling items which were kleptoparasitised. In mussels less than 5.2 cm long, the time involved handling prey which ultimately provided no energy return exceeded the time spent actually handling prey in successful attacks. Hammerers spent 30.8 s in false recognition and 22.9 s per successful attack. The time spent handling prey which ultimately provided no energy return exceeded 50% of the total handling time in all mussels less than 5.4 cm long.

(3.14) Indirect calorimetric studies of metabolism

(a) Resting metabolism (ϵ_{re})

(i) Windspeed

There was a significant linear relationship between ϵ_{re} and windspeed in the Oystercatcher ($n = 3$) at ambient temperatures between 17 and 22°C (Fig. 50). The regression equation $\epsilon_{re} (\text{J.s}^{-1}) = 3.06 + 0.121 \text{ windspeed (m.s}^{-1})$ explained 51.4% of the variability in ϵ_{re} . On average, the resting metabolism at a windspeed of 8 m.s⁻¹ was 1.31x the resting metabolism with no windspeed. Logarithmic transformation of either variable did not improve the explained variability in ϵ_{re} .

(ii) Temperature

The relationship between resting metabolism and temperature (T_a) in both adult and juvenile (1 yr. old) Redshank and adult Oystercatchers is shown in Fig 51 a-c respectively

In juvenile Redshank ($\bar{M}_{\text{Mass}} = 95 \text{ g}$) ($n = 4$) there was an inverse linear relationship between ϵ_{re} and temperature below 21°C. The fitted regression equation $\epsilon_{re} (\text{J.s}^{-1}) = 2.39 - 0.0569^\circ\text{C}$ ($n = 328$, $f = 710.4$, $p < 0.01$) explained 68.4% of the variability in metabolism.

Oystercatcher

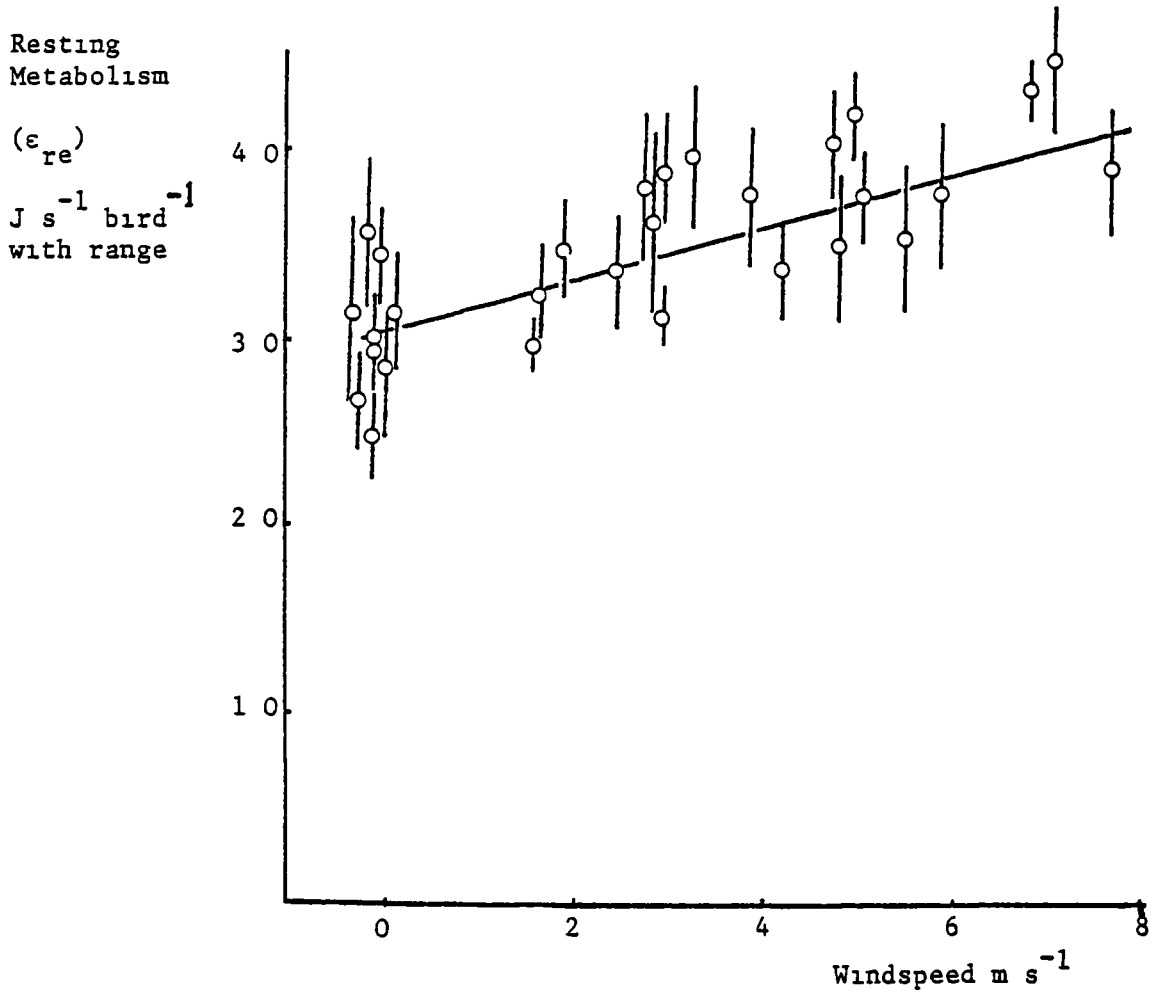

Fig 50 Resting energy metabolism (ϵ_{re}) of Oystercatchers ($n = 3$) against windspeed Mean bird mass $\cong 420 g$ Curve describes fitted regression equation

$$y (J s^{-1} bird^{-1}) = 3.06 + 0.121x (m s^{-1})$$

$$r^2 = 51.4$$

$$n = 32$$

$$F = 31.7$$

$$p < .001$$

Fig 51

Resting energy metabolism (ϵ_{re}) against ambient temperature

- (A) Juvenile Redshank (n = 4) \bar{x} mass = 95 g
fitted regression below T_{lc}

$$y \text{ (J s}^{-1} \text{ bird}^{-1}\text{)} = 2.39 - 0.0569 x \text{ (}^{\circ}\text{C)}$$

$$\begin{aligned} n &= 328 \\ F &= 710.4 \\ r^2 &= 68.4 \\ p &< .001 \end{aligned}$$

- (B) Adult Redshank (n = 6) \bar{x} mass = 149 g
fitted regression below T_{lc}

$$y \text{ (J s}^{-1} \text{ bird}^{-1}\text{)} = 3.04 - 0.0919 x \text{ (}^{\circ}\text{C)}$$

$$\begin{aligned} n &= 16305 \\ F &= 9918.6 \\ r^2 &= 34.5 \\ p &< .0001 \end{aligned}$$

- (C) Adult Oystercatcher (n = 2) \bar{x} mass = 596 g
fitted regression below T_{lc}

$$y \text{ (J s}^{-1} \text{ bird}^{-1}\text{)} = 4.03 - 0.0984 x \text{ (}^{\circ}\text{C)}$$

$$\begin{aligned} n &= 940 \\ F &= 310.2 \\ r^2 &= 24.6 \\ p &< .0001 \end{aligned}$$

T_{lc} = lower critical temperature of thermoneutral zone

T_b = predicted body temperature (Calder and King 1974)

Resting energy
metabolism (ϵ_{re})
($J s^{-1} bird^{-1}$)

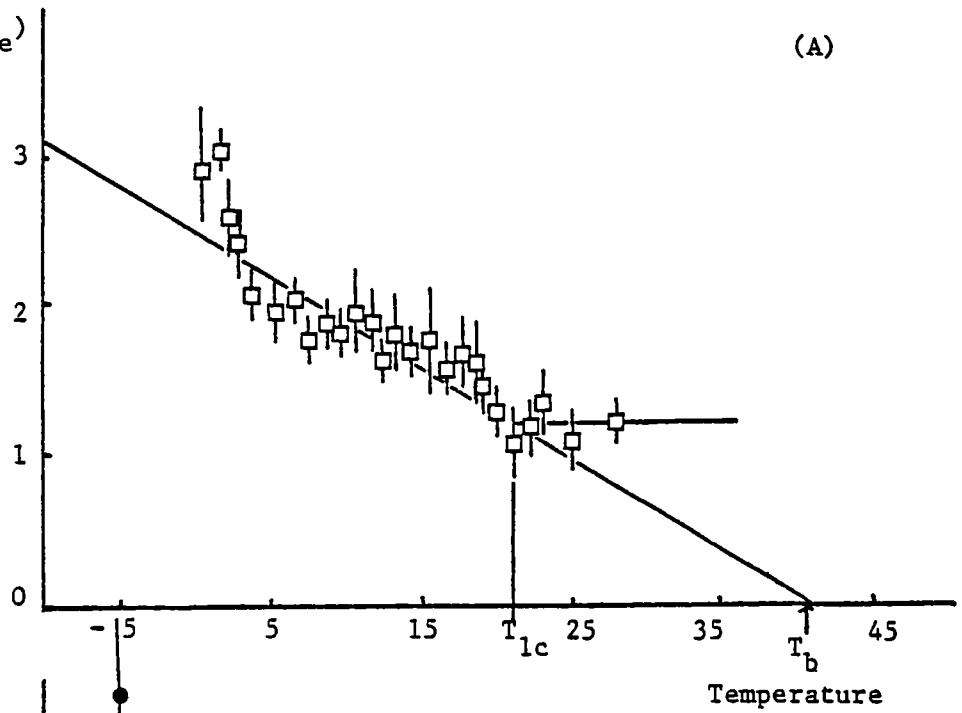

ϵ_{re}
 $J s^{-1} bird^{-1}$

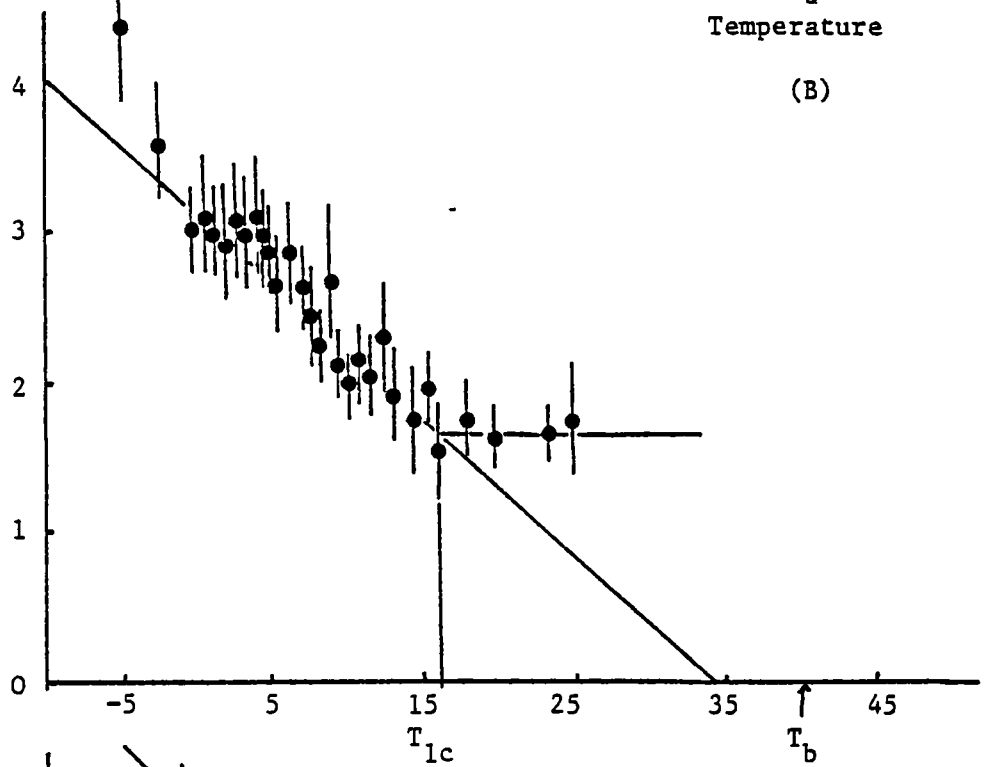

ϵ_{re}
 $J s^{-1} bird^{-1}$

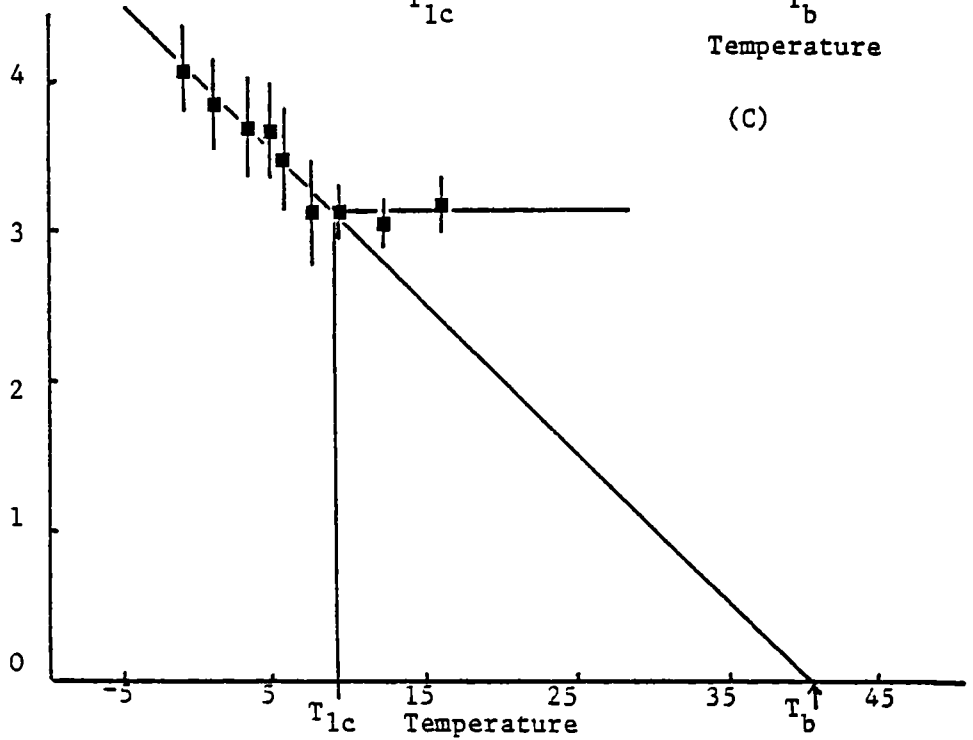

Logarithmic transformation of ϵ_{re} improved the r^2 to 74.9%. The calculated x intercept of the linear regression (below) 21°C was 41°C. Above 21°C metabolism was independent of temperature and averaged 1.19 J.s⁻¹.

In adult Redshank (\bar{x} Mass = 149 g) (n = 6) there was a significant inverse linear relationship between ϵ_{re} and temperature below 16°C. The fitted regression equation ϵ_{re} (J.s⁻¹) = 3.04 - 0.0919 T_a (°C) explained 34.5% of the variability in ϵ_{re} (n = 16305, F = 99186, p < .001). Logarithmic transformation of ϵ_{re} improved the r^2 to 38.4%. The calculated x intercept for the linear regression below 16°C was 33°C. Above 16°C metabolism was independent of temperature and averaged 1.56 J.s⁻¹.

In adult Oystercatchers (\bar{x} Mass = 596 g) (n = 2) there was a significant inverse linear relationship between ϵ_{re} and temperature below 9°C (Fig. 51(c)). The fitted regression equation ϵ_{re} (J.s⁻¹) = 4.03 - 0.0984 T_a (°C) explained 24.6% of the variability in ϵ_{re} (n = 950, F = 310.2, p < .0001). Logarithmic transformation of either variable did not improve the explained variability in ϵ_r (J.s⁻¹). Above 9°C the ϵ_{re} was independent of temperature and averaged 3.13 J.s⁻¹. The calculated x-intercept of the linear regression of metabolism on temperature (below 9°C) equalled 40.9°C.

(b) Active metabolism

(i) The energy cost of walking (ϵ_s)

The relationship between ϵ_s (J.s⁻¹) and walking speed for juvenile Redshanks forced to walk in a treadmill whilst wearing a close fitting mask at 20°C and 15°C are shown in Fig. 52. At both temperatures the metabolism increased linearly with increasing walking speed. The fitted regression equations did not have significantly

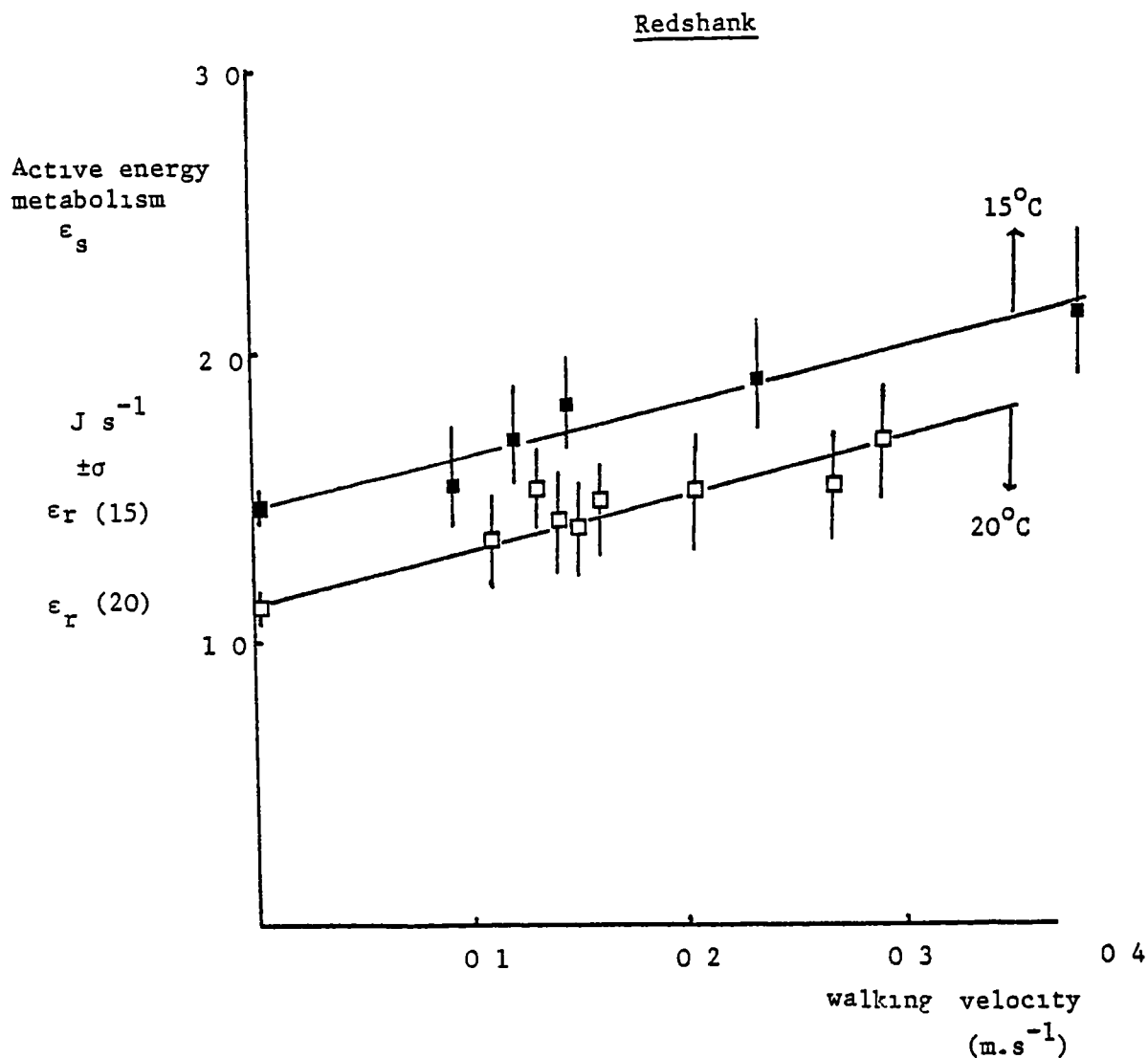

Fig 52 The energy expenditure whilst walking at two temperatures (15 and 20°C) against walking velocity in four Juvenile Redshank (mean mass = 95 g) The curves describe the fitted regression relationships

| | | |
|------|--|--------------|
| 15°C | $y = 1.46 + 1.5x \text{ (m s}^{-1}\text{)}$ | $r^2 = 56.7$ |
| | | $n = 143$ |
| | | $p < .001$ |
| 20°C | $y = 1.12 + 1.52x \text{ (m s}^{-1}\text{)}$ | $r^2 = 46.7$ |
| | | $n = 384$ |
| | | $p < .001$ |

The coefficients of the two regressions were not significantly different ($t = 0.05$, $p > .05$) Both intercepts were not significantly different from the predicted resting metabolism at 15 and 20°C ($\epsilon_r(15)$ and $\epsilon_r(20)$ respectively)

different coefficients (analysis of covariance, $t = 0.05$, $p > .05$) but did have significantly different constants ($t = 2.6$, $p < .001$)

The intercepts of the fitted regression equations, on the metabolism axis, at both temperatures, were not significantly different from the predicted resting metabolism (ϵ_{re}) (3.14.a(ii)), at the same temperatures.

(3.15) Radio telemetric studies of metabolism

(a) The relationship between CO₂ production, O₂ consumption, and heart rate over short (2.5 s) periods in the laboratory

Because of the time taken to draw respiratory gases through the respirometry system (Fig. 9) simultaneous estimates of CO₂ production and O₂ consumption were poorly related. Estimates of O₂ consumption were therefore progressively lagged behind CO₂ estimates and the correlation (r) between the two variables was calculated at each lag. In all the individuals, a distinct peak occurred in the explained variability. The number of lags required to reach the peak was inversely related to the flow rate of gases through the system.

The maximum explained variability in oxygen consumption by carbon dioxide production varied between 40 and 80%. RQ was calculated at the position of maximum intercorrelation for each 2.5 s period. These short duration estimates of RQ varied between 0.4 and 1.98 and across all six birds averaged 0.8546 ($n = 21,190$, $\sigma = 0.12$). RQ increased significantly with increases in ambient temperature and decreased with both increases in the size corrected body mass (body mass. bill length⁻¹) and time since placed in the respirometer (Fig. 53 a-c). The fitted multiple regression equation $RQ = 0.969 + 0.005 T_a (^{\circ}C) - 0.04 (\text{Body mass (g)/bill length (mm)}) - 0.000286 (\text{min})$ since into

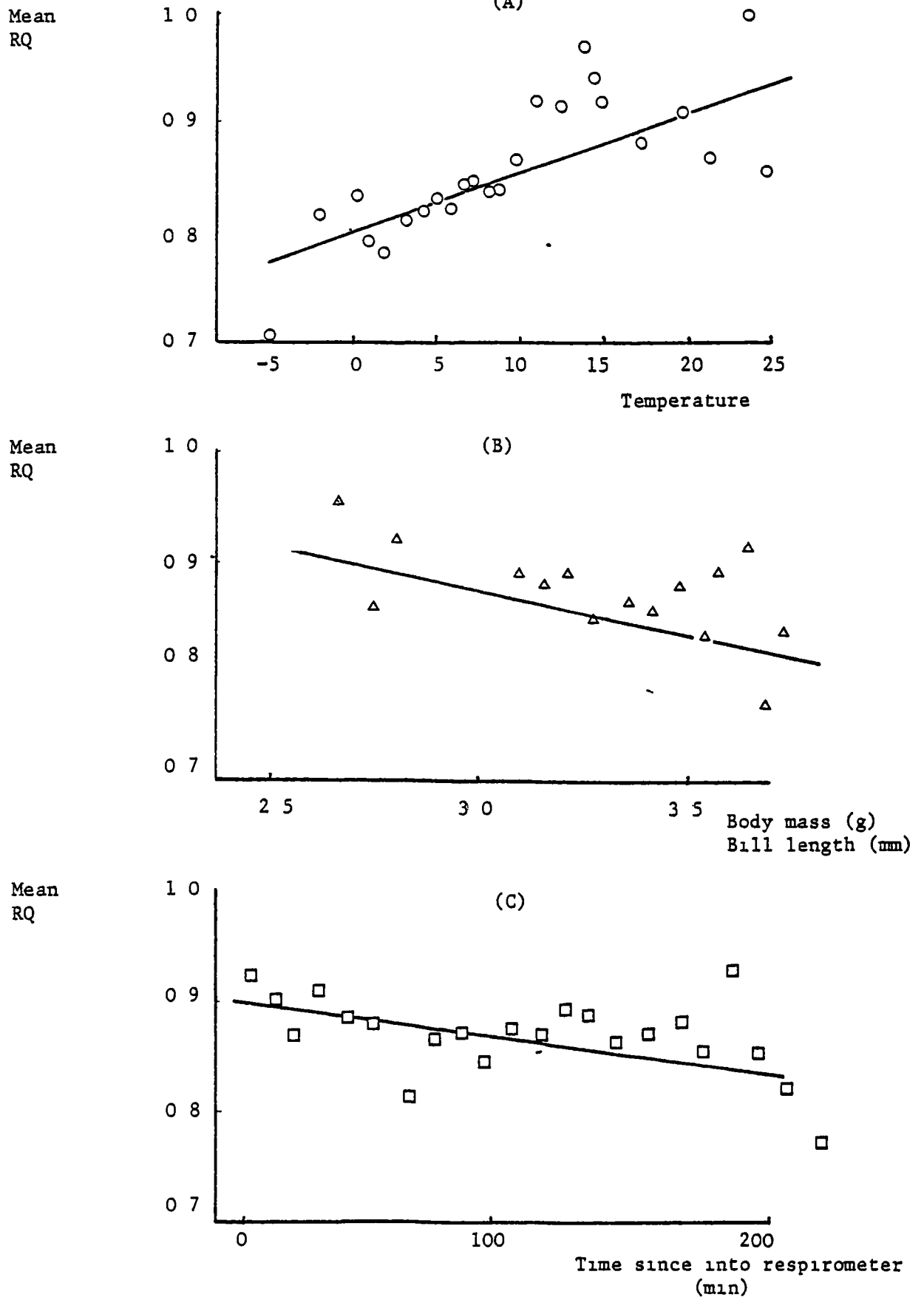

Fig 53 Mean respiratory quotient (RQ) against ambient temperature (A), size corrected body mass (Body mass/bill length) (B), and time since into the respirometer (C), in adult Redshank ($n = 6$) Curves describe fitted regression relationships (all curves significant $p < .001$, $n = 21, 190$)

respirometer, explained 3.5% of the variability in the short duration RQ.

Because of the large variability in short duration RQ, which was mostly explained by different characteristics of the gas analysers (see discussion 4.14), estimates of ϵ_{re} ($J.s^{-1}$) were calculated for each 2.5 s period by conversion of the estimated CO_2 production using the RQ estimated from the above equation. Estimated carbon dioxide production was used in preference to oxygen consumption because of the more rapid response-time of the infra-red gas analyser.

Estimates of energy expenditure ϵ_{re} ($J.s^{-1}$) were correlated with heart rates (H_R) with progressive lags in a similar manner to estimates of CO_2 and O_2 production (above - see also Lund and Folk 1976). As with intercorrelations of CO_2 and O_2 , there was a clear peak in the explained variability of ϵ_{re} by heart rate. The mean lag required to reach the point of maximum correlation was 7.5 s which approximately equalled the time required to draw aliquots of CO_2 injected into the mask through the system to the Infra-red gas analyser (7.0 s), at the flow rates employed.

Simultaneous (corrected for apparatus lag) estimates of ϵ_{re} ($J.s^{-1}$) and heart rate over a two minute period at 6°C in Bird (D) are shown in Fig. 54. Bouts of activity - wing shuffling, walking around the box etc. were accompanied by rapid increase in both heart rate and metabolism, although there was often a slight delay between the onset of activity and the increase.

Within each individual there was a significant positive linear relationship, across temperatures, between heart rate and metabolism. The explained variability in ϵ_{re} by heart rate alone was low (17 - 41.1%). Logarithmic transformation of both variables improved the r^2 by on average 5%. Within each individual there was also a significant

independent negative effect of temperature (T_a). With T_a included the regression coefficient of metabolism on heart rate was lower than when temperature was excluded. Linear regression coefficients and constants from the fitted regression equations relating ϵ_{re} ($J.s^{-1}$) with both T_a and heart rate (H_R) in each individual are shown in Table 18.

With both temperature and heart rate included, the explained variability in ϵ_{re} varied between 35.2 and 79.5%. In all the birds logarithmic transformation of one or more variables improved the explained variability. The effect of a given transformation across individuals was inconsistent, and the increase in explained variability was small (Table 19).

Both the regression constants and coefficients differed significantly between individuals. Estimates of ϵ_{re} across individuals were entered as the dependent variable in a multiple regression analysis with heart rate, temperature and body mass (corrected for size differences between individuals) as independent variables. Significant independent effects were found for all three variables. The multiple regression explained 52.2% of the variability in ϵ_{re} . (Table 20)

(3.16) Estimates of energy expenditure in the aviary

(a) Variation in heart rate/ ϵ_{re} throughout short bouts of spontaneous activity

Estimates of ϵ_{re} ($J.s^{-1}$), interpolated from equations relating heart rate and metabolism (above) for five seconds prior to, during and for ten seconds after spontaneous walks of 9-11 seconds duration (with the predicted resting metabolism (below)), across four birds (A, C, E and

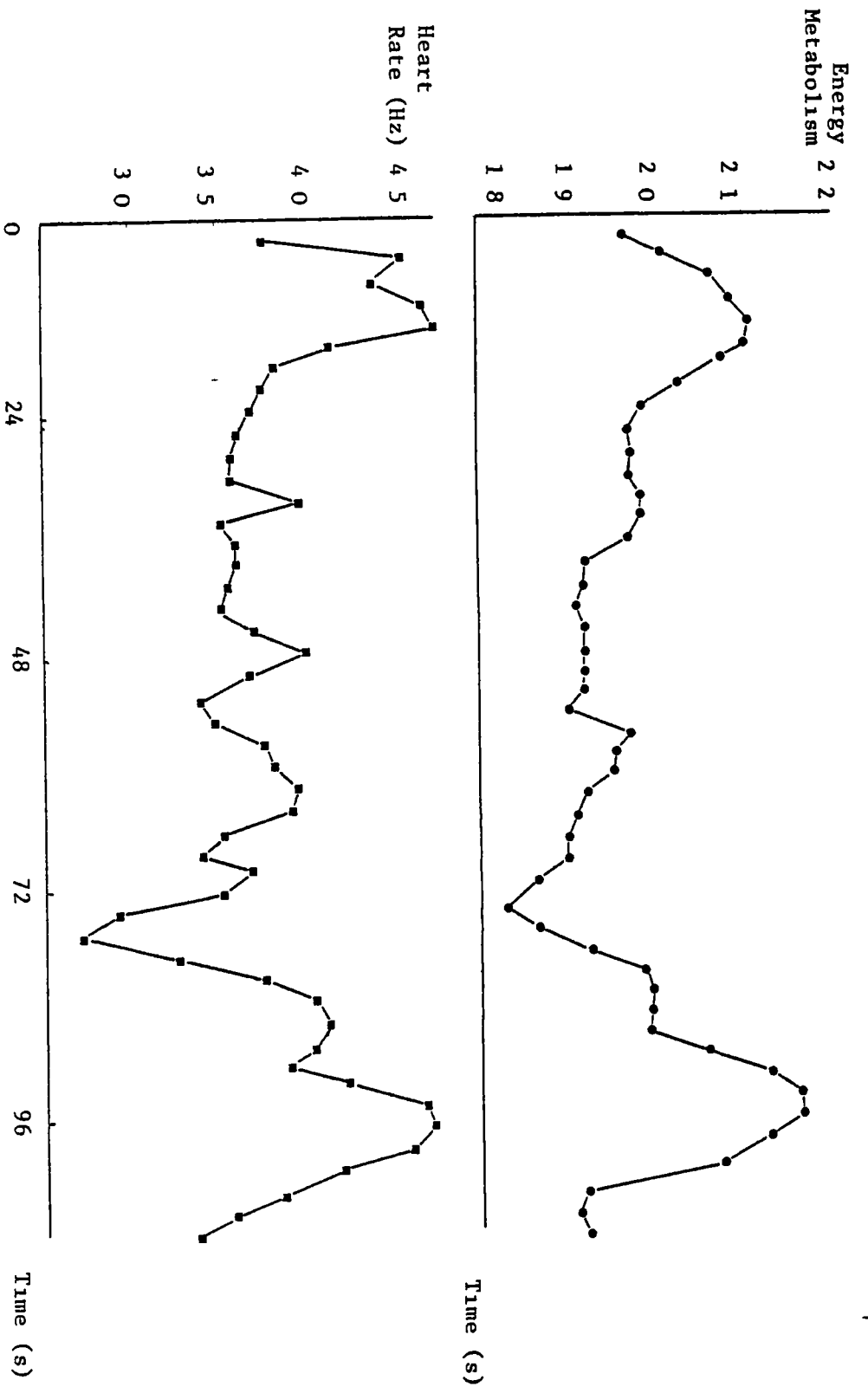

Fig 54 Simultaneous (corrected for lag in apparatus) estimates of energy metabolism (J s^{-1}) and heart rate in an adult Redshank (Bird D) over a two minute period at 6°C

Table 18

Linear regression coefficients (b_1 and b_2) and constants (a) from equations of the form

$$(J.s^{-1}) = a + b_1 \text{ Heart rate (Hz)} - b_2 \text{ Temperature (}^\circ\text{C)}$$

for six individual Redshank

| Bird | Regression Constant $a \pm \sigma$ | | Regression Coefficient $b_1 \pm \sigma$ (Heart rate) | | Regression Coefficient $b_2 \pm \sigma$ (Temperature) | | Max. multiple r^2 | n |
|------|---------------------------------------|------|--|-------|---|-------|---------------------------|------|
| (A) | 2.33 | 0 08 | 0 218 | 0.01 | -0 106 | 0.001 | 73 7 | 4800 |
| (B) | 3.77 | 0.04 | 0 098 | 0.008 | -0 06 | 0.001 | 35.2 | 4800 |
| (C) | 1 29 | 0 03 | 0 519 | 0 007 | -0 056 | 0.002 | 64.5 | 3611 |
| (D) | 1.84 | 0 04 | 0 179 | 0 006 | -0 0467 | 0.001 | 56.5 | 2400 |
| (E) | 0 772 | 0 04 | 0.524 | 0 01 | -0 0258 | 0 002 | 54 7 | 3169 |
| (F) | 1.33 | 0 07 | 0.511 | 0 01 | -0 0332 | 0 002 | 79.5 | 2400 |

Table 19

The effects of logarithmic transformation of metabolism, heart rate and temperature on the variability in metabolism explained by variations in heart rate and temperature, for six individual Redshank (A to F)

| Transformed Variable | | % Variability ($r^2 \times 100$) | | | | | | | | |
|----------------------|--------|------------------------------------|------|------|------|------|------|------|-----------|-------|
| e | H rate | ToC | A | B | C | D | E | F | \bar{x} | r^2 |
| LIN | LIN | LIN | 76.3 | 35.2 | 64.5 | 57.1 | 77.4 | 40.6 | 58.51 | |
| LIN | LOG | LIN | 80.9 | 32.9 | 64.7 | 53.8 | 77.4 | 41.8 | 58.58 | |
| LIN | LIN | LOG | 76.2 | 40.4 | 64.3 | 56.6 | 74.3 | 48.8 | 60.10 | |
| LIN | LOG | LOG | 80.9 | 33.7 | 64.6 | 53.9 | 74.6 | 49.7 | 59.51 | |
| LOG | LIN | LIN | 79.1 | 35.2 | 62.9 | 62.2 | 74.0 | 39.7 | 58.85 | |
| LOG | LOG | LIN | 79.1 | 35.2 | 63.0 | 57.8 | 73.7 | 41.2 | 58.85 | |
| LOG | LIN | LOG | 81.5 | 43.9 | 64.9 | 62.0 | 73 | 46.7 | 62.0 | |
| LOG | LOG | LOG | 81.6 | 36.0 | 65.1 | 57.9 | 72.8 | 47.9 | 60.21 | |

Table 20

The results of a multiple regression analysis of metabolism ($J.s^{-1}$) on heart rate (Hz), Temperature ($^{\circ}C$) and size corrected body mass (body mass (g)/bill length (mm)) Data pooled across six Redshank.

| Independent variable | Regression Coefficient | σ of Coefficient | t (coefficient equals 0) |
|------------------------------------|------------------------|-------------------------|--------------------------|
| Constant | 0.8566 | 0.0457 | 18.75 |
| Heart rate (Hz) | 0.1818 | 0.0040 | 45.71 |
| Temperature ($^{\circ}C$) | -0.0628 | 0.0005 | 113.24 |
| Size corrected mass (gmm^{-1}) | 0.3901 | 0.0120 | 32.41 |

Analysis of variance

| Source | d f. | SS | MS | F ratio | Probability |
|---------------------|--------|----------|--------|---------|-------------|
| Regression | 3 | 6279.6 | 2093.2 | 8046.1 | < .001 |
| Heart rate | 1 | 2848.5 | 2848.5 | 10949.3 | < .001 |
| Temperature | 1 | 3157.7 | 3157.7 | 12137.8 | < .001 |
| Size corrected mass | 1 | 273.3 | 273.3 | 1050.5 | < .001 |
| Residual | 22,100 | 5749.4 | 0.3 | | |
| Total | 22,103 | 12,029.0 | | | |

F) at 7°C, are shown in Fig. 55.

During the five seconds before walking some birds showed an anticipatory rise in ϵ_{re} . Across all individuals and runs (n = 28) however, changes in pre-walk ϵ_{re} were not significantly different from resting (p > .05). ϵ_{re} increased rapidly at the start of walking and then more slowly and eventually peaked as walking stopped. Metabolism remained elevated once walking stopped. After approximately seven seconds it had declined to a level not significantly different from the predicted resting level.

The difference between the predicted and actual ϵ_{re} during the seven seconds after walking had ceased (= 3 Joules) (= area A, Fig. 55) was approximately equal to the difference between the peak metabolism throughout the period and that actually recorded throughout the walking duration (= 3.06 Joules) (= area B, Fig. 55). Similar data were found for other activities and at different temperatures.

(b) Effects of observer handling

Whilst having the transmitter attached to the harness, and immediately upon release into the aviary, all the birds had very high heart rates (c.10 - 12Hz), even though they appeared calm. Over the subsequent twenty minutes heart rates, recorded during a given behaviour, decreased non-linearly until after approximately twenty minutes the heart rate was independent of the time since handled for a given behaviour (e.g. resting - Fig. 56). All the estimates of energy expenditure (below) were collected at least 25 minutes after release into the aviary.

(c) Predicted ϵ during various behaviours

(i) Resting (ϵ_{re})

ϵ_{re} from birds which had been resting for at least two minutes, increased significantly with decreases in ambient temperature (T_a) and

Energy
expenditure
($J s^{-1}$)
+ Standard
error

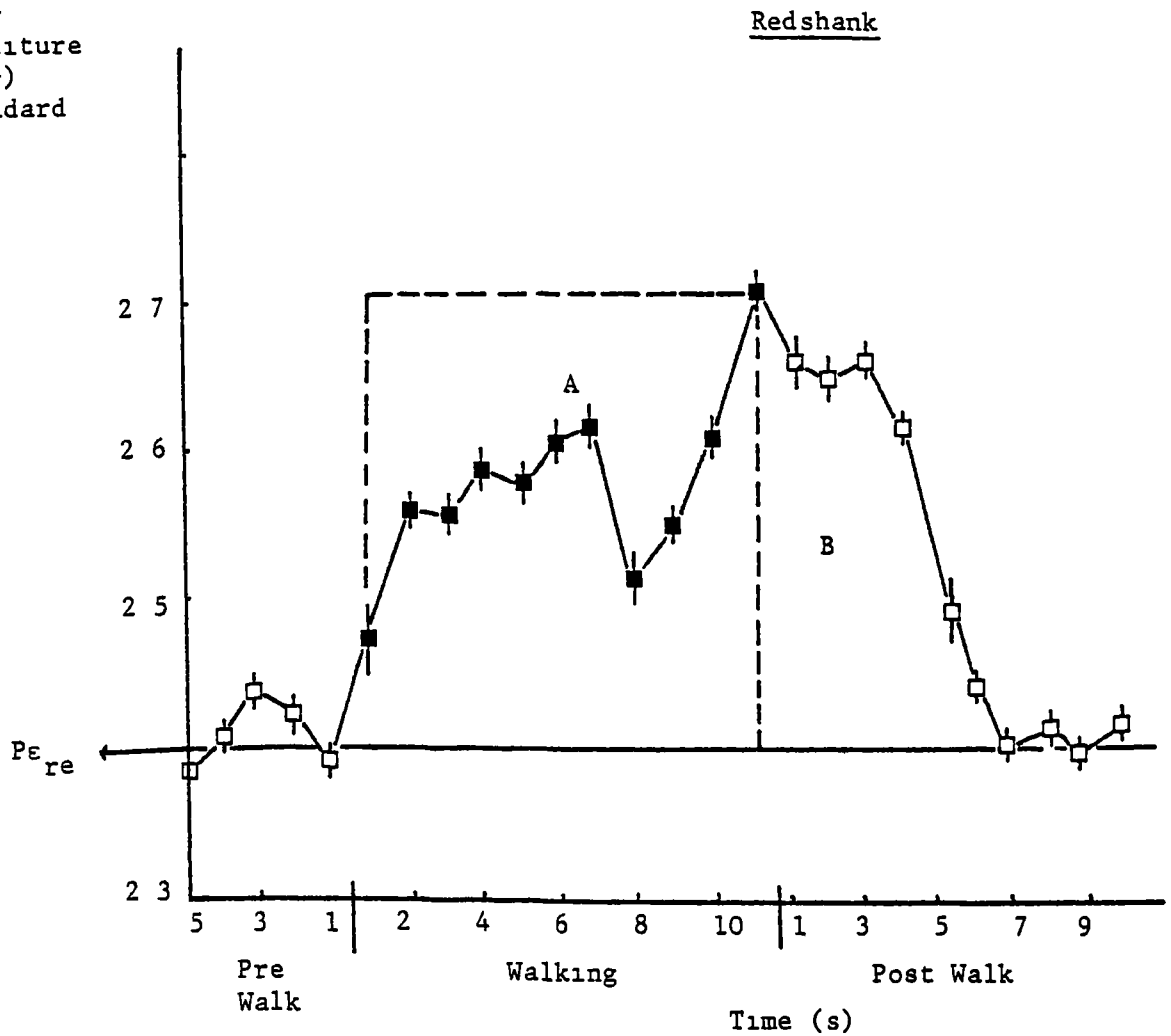

Fig 55 Changes in predicted energy expenditure, before, during and after spontaneous walks of 10 - 11 s duration, in four adult Redshank at 7°C (n = 28). The predicted resting metabolism at 7°C equals $P\epsilon_{re}$. The difference between the peak energy expenditure and that observed throughout the walk (Area A), was approximately equal to the difference between the observed metabolism after the walk and the predicted resting metabolism (Area B). Closed symbols equal walking.

Mean heart rate
when resting
(Hz)

with range

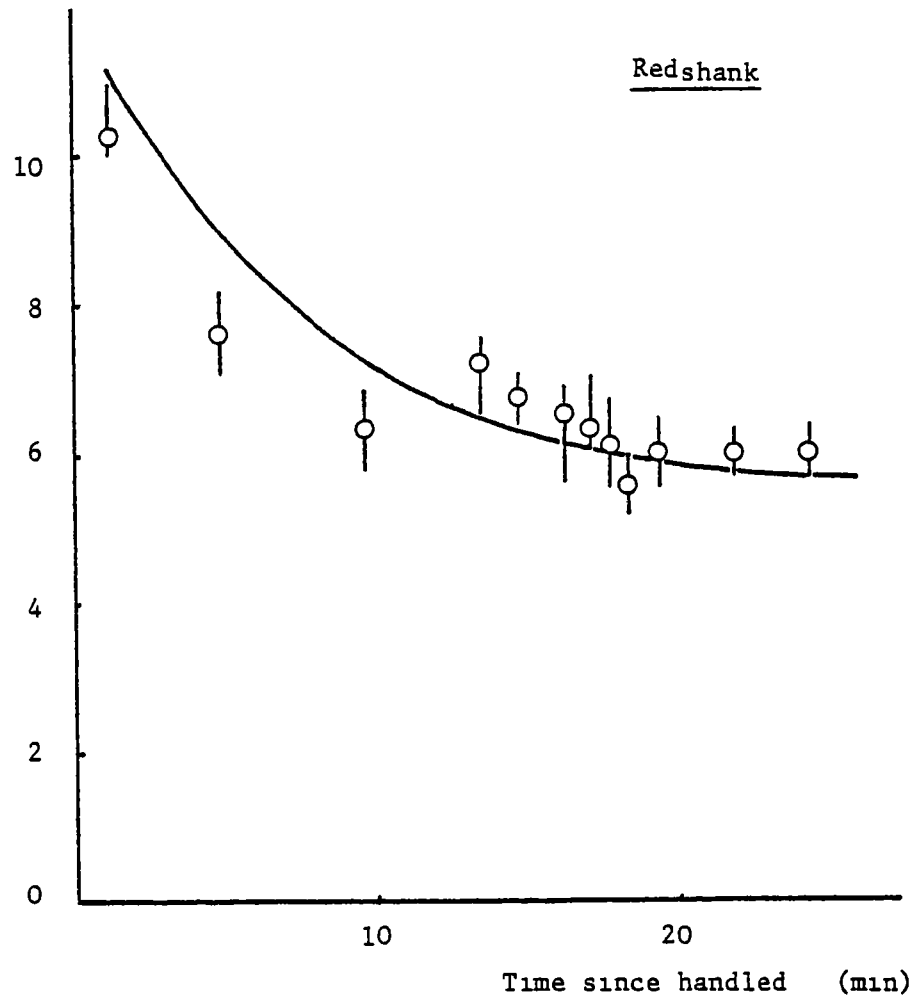

Fig 56 Heart rate whilst resting against time since handled (Data from two Redshank at 5°C) The curve describes the fitted regression equation

$$y \text{ (Hz)} = 10.76 - 3.7 \log_{10} \text{ Time (min)}$$

$$r^2 = -0.967$$

$$F = 895.72$$

$$n = 65$$

$$p < 0.001$$

increases in body mass (both corrected and uncorrected for size differences between individuals). (Table 21) The predicted relationship for a bird of body mass 150 g was $\epsilon_{re} \text{ (J.s}^{-1}\text{)} = 3.02 - 0.0855 (T_a \text{ } ^\circ\text{C})$. Deviations between the ϵ_{re} predicted from the above equation and ϵ_{re} predicted from the relationship between ϵ_{re} and T_a established by indirect calorimetry (section 3.14.1(b)) in the same individuals (\bar{x} mass = 149 g) over the temperature range 0 - 16°C, averaged only 2.7% of the heart rate estimates, and 2.84% of the indirect calorimetry estimates.

(ii) Prey searching - visually (= walking) ϵ_s

Estimates of ϵ_s whilst spontaneously walking for short periods (c.10 s) increased with increasing walking speed and body mass and decreased with increasing temperature. The two-way interactions between walking speed and temperature and walking-speed and body mass were not significant ($p > .05$). The interaction of temperature and body mass was significant at the .05 level, but not the .01 level and only added 2% to the explained variability and was therefore excluded in a stepwise multiple regression. The three-way interaction was not significant ($p > .05$). (Table 21)

Predicted ϵ_s interpolated from the above equation against walking speed and temperature, for a Redshank of body mass 150 g, is plotted in Fig. 57, with the predicted resting metabolism. The incremental cost of transport was independent of temperature and equalled 0.382 $\text{J.m}^{-1}.\text{s}^{-1}$. This was only 22% of the estimate obtained by indirect calorimetry in juveniles (section 3.14.2).

There was no significant difference between the estimated cost of walking at 0 m.s^{-1} and ϵ_{re} at 16°C (T_a). The difference increased as temperature declined below 16°C. The coefficient of the

Table 21

Coefficients and constants from linear regression equations of the form

$$\epsilon \text{ (J s}^{-1}\text{)} = a + b_1 \text{ Temperature (}^\circ\text{C)} + b_2 \text{ Body mass (g)} \\ (+ b_3 \text{ walking speed (m.s}^{-1}\text{)})$$

from biotelemetry estimates of metabolism (ϵ) across six adult Redshank, whilst performing various behaviours, in an outdoor aviary (n = number of metabolism estimates).

| Behaviour | (a) Const | Coefficients | | | n | r ² |
|----------------------|--------------|---------------------------|--------------------------|-------------------------|------|----------------|
| | | b ₁ (Temp.) | b ₂ (Mass) | b ₃ Speed | | |
| Resting | 1.54 | -0.0855 | +0.00986 | - | 5290 | 70.5 |
| Walking | 0.99 | -0.121 | +0.0168 | + 0.382 | 1038 | 70.6 |
| Tactile searching | 3.45 | -0.0962 | - | - | 472 | 49.9 |
| Pecking | 2.75 | -0.0976 | +0.0047 | - | 709 | 50.2 |
| Probing | 2.29 | -0.733 | +0.0123 | - | 143 | 79.4 |
| | | log _e T°C | | | | |

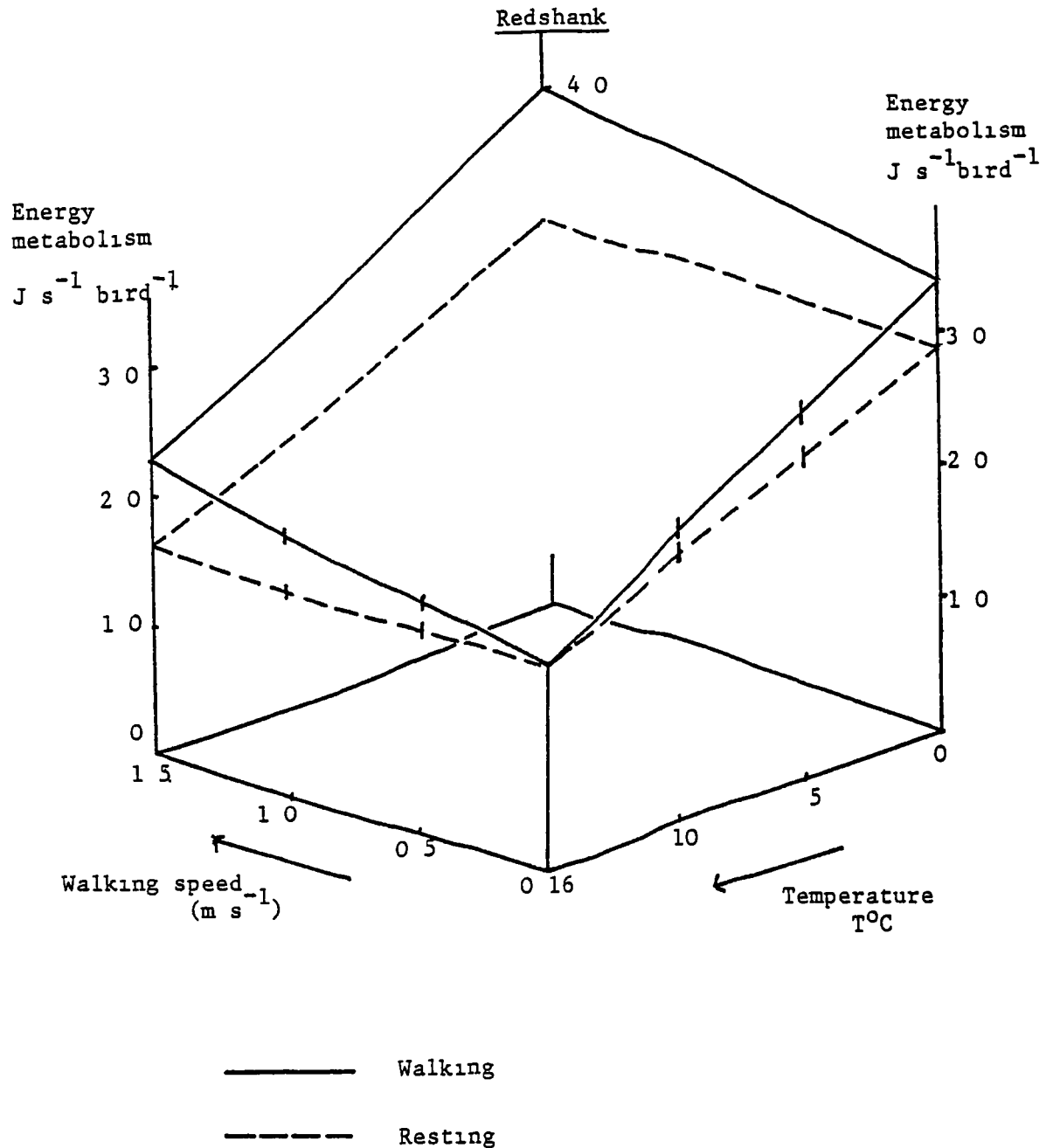

Fig 57 Predicted energy metabolism of a 150 g Redshank whilst walking (solid plane) and resting (broken plane) against walking speed and temperature (Values interpolated from fitted regression equations to data collected from six adult Redshank) Error bars show standard deviation of the predicted metabolism (n (data for regression) walking = 1038, rest = 5290) Note - the predicted basal metabolism (BMR) averaged from predictions of Lasiewski and Dawson (1967), Aschoff and Pohl 1970, and Kendleigh 1977, for a non-passerine bird of 150 g equals $1.02 \text{ J s}^{-1} \text{ bird}^{-1}$

Table 22

Estimates of metabolism ($J s^{-1}$) of a 150 g Redshank whilst resting, walking and foraging at five temperatures. Estimates interpolated from regression equations relating metabolism with temperature and body mass (and walking speed) - see Table 21

| Behaviour | Temp. ($^{\circ}C$) | | | | |
|--------------------|-----------------------|------|------|------|------|
| | 0 | 4 | 8 | 12 | 16 |
| Resting | 3.03 | 2.66 | 2.31 | 1.95 | 1.60 |
| Walking (30 cm/s) | 3.63 | 3.14 | 2.66 | 2.17 | 1.68 |
| Walking (100 cm/s) | 3.89 | 3.41 | 2.92 | 2.44 | 1.95 |
| Tactile search | 3.45 | 3.06 | 2.68 | 2.29 | 1.91 |
| Pecking | 3.45 | 3.06 | 2.67 | 2.28 | 1.89 |
| Probing | 4.13 | 3.06 | 2.53 | 2.21 | 1.99 |

σ for all predictions = $0.12 - 0.15 J s^{-1}$

$16^{\circ}C - T_{lc}$

Note - BMR predicted for non-passerine bird of 150 g = $1.0 - 1.04 J s^{-1}$,
(Ashcoff and Phol 1970, Kendeigh 1970, Lasiewski and Dawson 1967)

temperature v ϵ_s relationship ($0.121 \text{ J.s}^{-1}.\text{°C}^{-1}$) was significantly greater than the same coefficient in resting birds ($0.0855 \text{ J.s}^{-1}.\text{°C}^{-1}$). (Table 21, Figure 57)

The coefficient of the body mass v metabolism relationship when walking was significantly greater than the same coefficient in resting birds. (Table 21)

(iii) Prey searching - tactile method (ϵ_s)

It was not possible to obtain a relationship between the Tactile searching ϵ_s and body mass as only four birds of similar mass fed in this manner. ϵ_s decreased as temperature increased (Table 21). The coefficient of ϵ_{re} on temperature ($0.0962 \text{ J.s}^{-1}.\text{°C}^{-1}$) was significantly greater than the coefficient when resting (Table 21).

(iv) Prey handling - pecking (ϵ_h)

The ϵ_h whilst pecking increased as body mass increased and temperature decreased (Table 21). The coefficient of ϵ_h on temperature was significantly greater, and the coefficient of ϵ_h on body mass significantly lower, than the same coefficients in resting birds.

(v) Prey handling - probing (ϵ_h)

The ϵ_h during bouts of probing increased as body mass increased and temperature decreased. The relationship of ϵ_h to temperature was non-linear (Table 21). The coefficient of ϵ_h on body mass ($0.123 \text{ J.s}^{-1}.\text{°C}^{-1}$) was significantly greater than the same coefficient in resting birds (above).

(d) Comparison of the ϵ whilst prey searching, prey handling and resting at temperatures below T_{1c}

The predicted ϵ whilst resting, walking at 30 cm s^{-1} and 100 cm s^{-1} , tactile searching, pecking and probing, for a Redshank of body mass 150 g, at ambient temperatures 0, 4, 8, 12 and 16°C , interpolated from the

regression equations in Table 21, are shown in Table 22.

On average, across all temperatures between 0°C and 16°C the most costly behaviour was fast walking (1 m.s⁻¹) ($\bar{x} = 2.86 \text{ J.s}^{-1}$, $n = 16$, $\sigma = 0.57$). Tactile searching, pecking and probing had similar ϵ 's (means equal 2.63, 2.62 and 2.65 respectively across temperature). Slow walking (30 cm s⁻¹) was the least costly activity ($\bar{x} = 2.56 \text{ J.s}^{-1}$, $n = 16$, $\sigma = 0.42$). ϵ_{re} was significantly lower than the ϵ for all activities ($p < .001$, Sign test).

Because of the increase in the fixed cost of locomotion with decreases in temperature below T_{lc} (above, and section 4.15) the ϵ whilst slow walking (30 cm s⁻¹) (= visual searching speed) was lower than the cost of tactile searching above 7°C but of greater cost below 7°C.

PART TWO MODEL PREDICTIONS AND TESTS

(3.17) Search strategy

(a) The relationship between pacing rate, walking speed and stride length

In both Redshank and Oystercatcher there was a significant positive curvilinear relationship between pacing rate and walking speed (Fig. 58, Table 23). The coefficients of the regression equations were not significantly different ($t = 0.06$, $p > .05$) but the constants were ($t = 46.3$, $p < .002$). At a given walking speed Redshank paced more rapidly than Oystercatchers.

In both species increases in walking speed were also correlated with increases in stride length (Fig. 59, Table 23). At a given walking speed Oystercatchers had longer strides than Redshank.

The maximum observed walking speeds were 1.25 m.s⁻¹ in Redshank and 1.5 m.s⁻¹ in Oystercatchers.

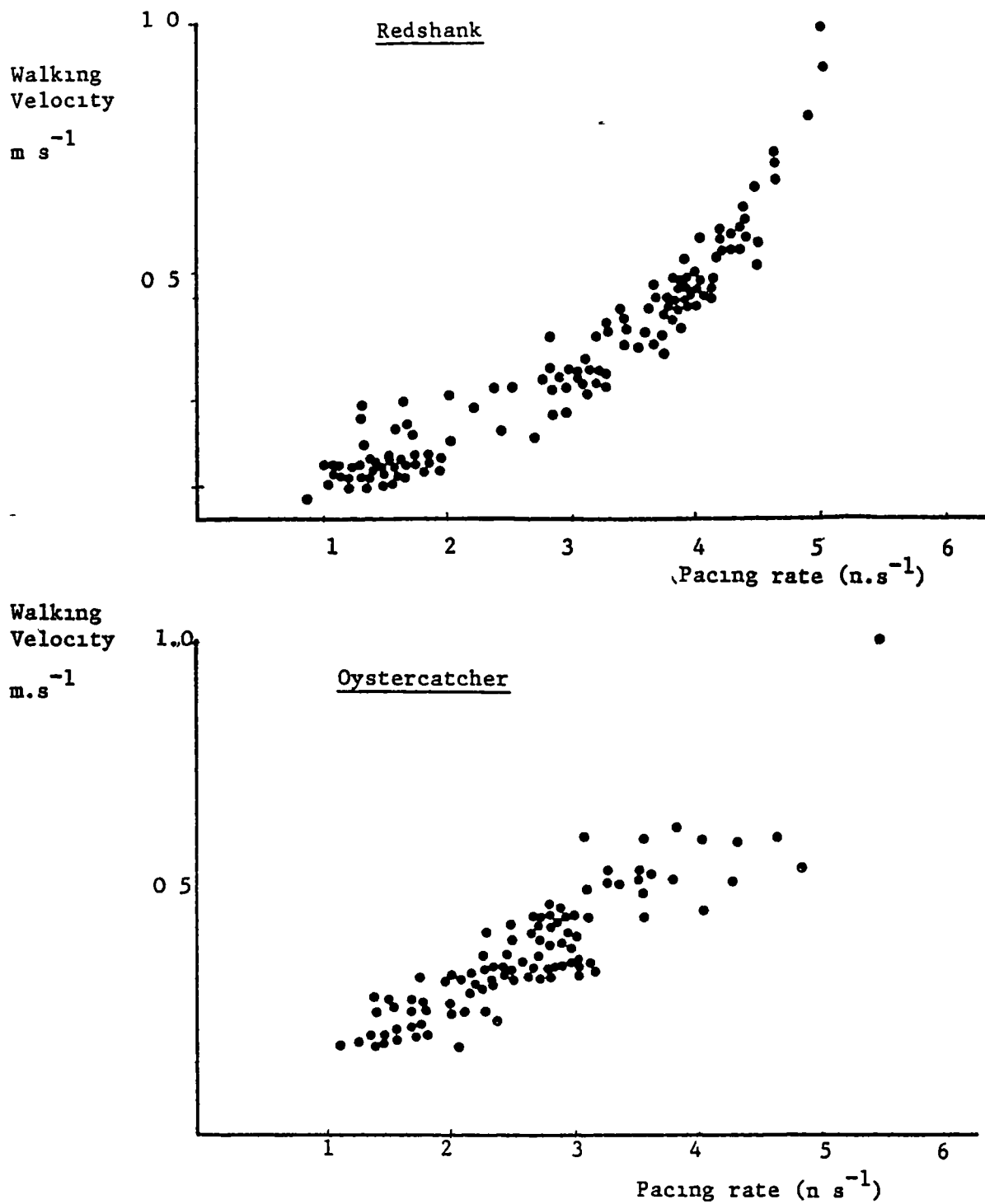

Fig 58 Walking velocity against pacing rate in the Redshank ($n = 97$) and Oystercatcher ($n = 127$) The fitted regression equations
 Redshank $\log_e y = 2.21 + 1.46x$
 Oystercatcher $\log_e y = 1.9 + 1.46x$
 were both significant ($p < 0.01$) At a given walking velocity Redshank paced more rapidly than Oystercatcher

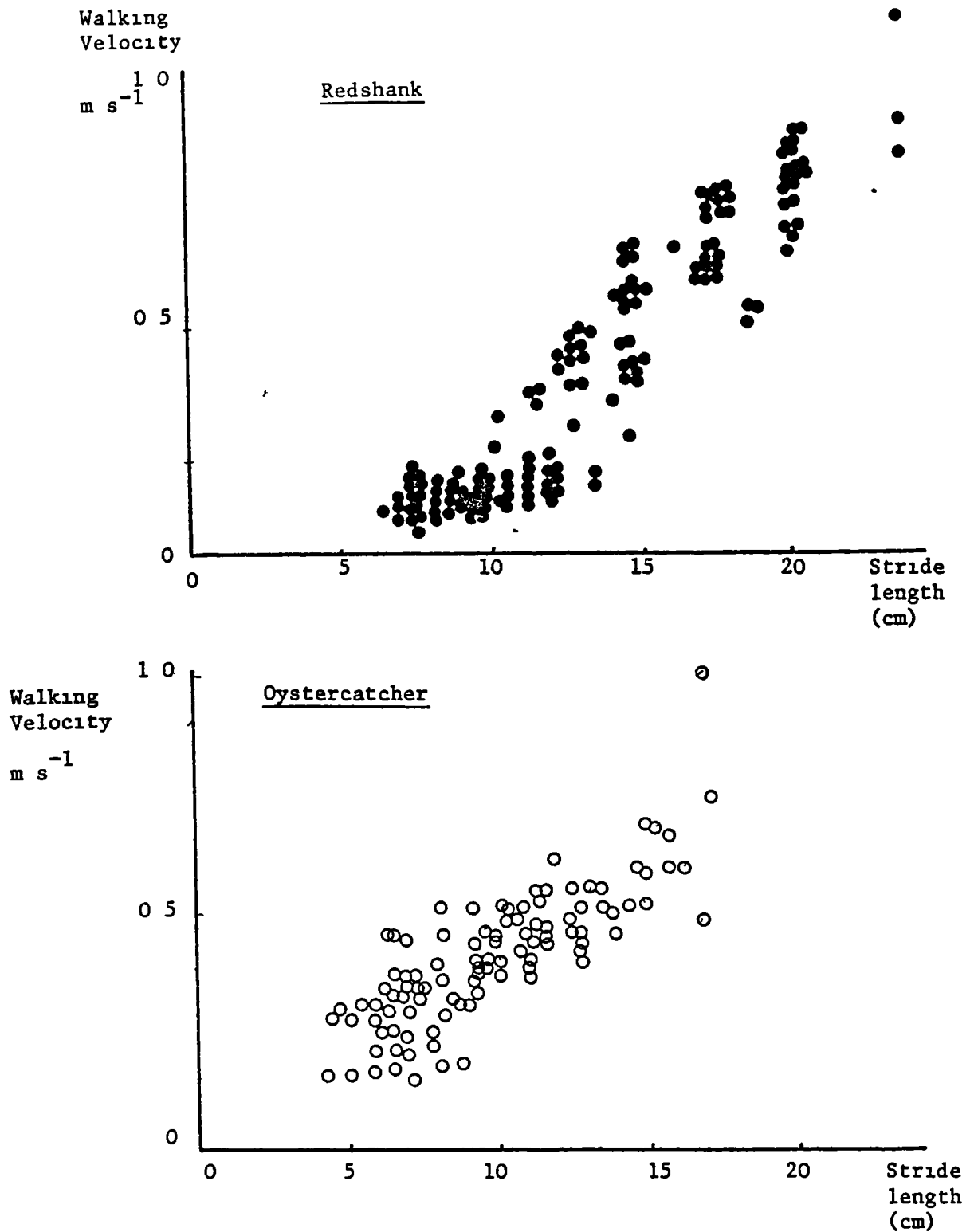

Fig 59

Walking velocity against stride length in the Redshank (n = 97) and Oystercatcher (n = 127). The fitted regression equations

Redshank $y = -2.47 + 2.27x$

Oystercatcher $y = -0.355 + 1.57x$

were both significant ($p < 0.01$). At a given walking velocity Redshank made shorter strides than Oystercatchers.

Table 23

Coefficients and constants from regression equations of walking speed ($\log_e \text{ cm s}^{-1}$) on pacing rate (n s^{-1}) or stride length (cm) in Redshank and Oystercatcher

| Predator | Dependent Variable | Coefficient | Constant | $r^2 \times 100$ |
|---------------|---------------------------|-------------|----------|------------------|
| Redshank | \log_e Pacing Rate | 1.46 | 2.21 | 93.3 |
| | \log_e Stride length | 2.27 | -2.47 | 81.5 |
| Oystercatcher | \log_e Pacing Rate | 1.46 | 1.9 | 78.2 |
| | \log_e Stride length | 1.57 | -0.355 | 72.8 |

(3.17 1) Redshank - visual searching · walking speed(a) The predicted relationship between walking speed and prey encounter rate

The predicted relationship between predator walking speed (v_x) and prey encounter rate ($D p_a \cdot x$) for a terrestrial predator of body mass 150 g, derived from equations 12, 14 and 15 (Chapter 1.2), is shown in Fig. 60(a). [For fuller discussion see Chapter 1.2].

(b) The observed relationship between walking speed and prey encounter rate

Pacing rates (P_R) of Redshank were calculated over short (c. 30 s) periods.

$$P_R = n_p / (T - \sum_{i=1}^{n_{pe}} n_i \cdot T_{ti}) \quad (31)$$

where n_p = the number of paces in the observation period

T = the duration of the observation

n_{pe} = the number of prey classes (= 8, section 2.14)

n_i = the number of the i th item ingested in T

and T_{ti} = the handling time of the i th item (section 3.10)

(see Goss Custard and Rothery 1976).

P_R were converted to walking speeds using the empirically derived relationship (3.17).

Within each site there was a significant inverse relationship between walking speed and prey encounter rate (n items ingested + false recognitions. m walked⁻¹) Pooled data across sites are shown in Fig. 60(b).

Predicted and observed walking speeds were not significantly different above approximately 2 encounters. m^{-1} (predicted walking speed = 30 $cm \cdot s^{-1}$). At lower encounter rates the birds walked significantly slower than predicted by the model (Chapter 1.2). At no

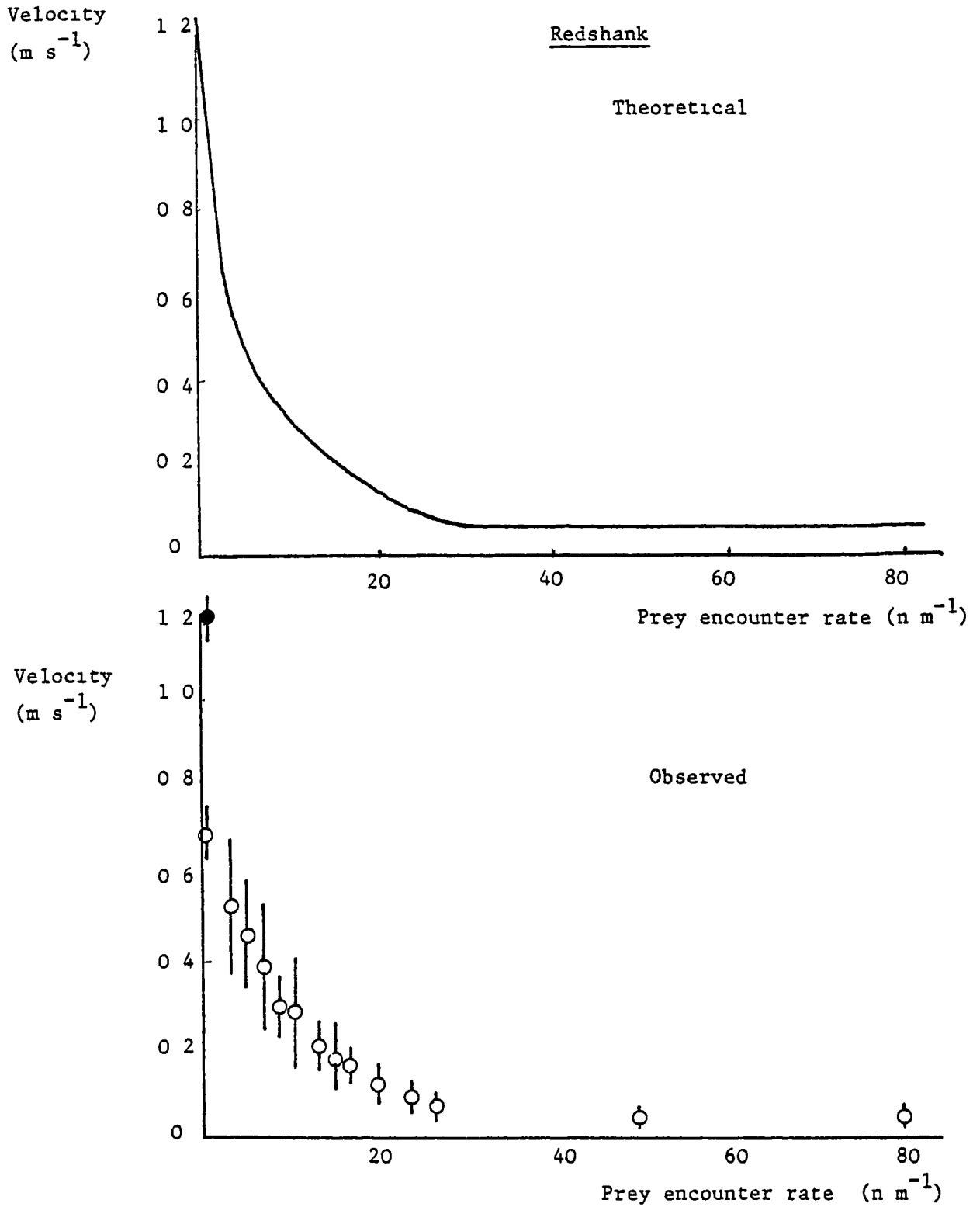

Fig 60

Theoretical and observed walking velocities against prey encounter rate ($n\ m^{-1}$) walked) in the Redshank. Observed data pooled across plots and seasons. The curve in the lower graph describes the least squares fit regression equation

$$\log_e y = -0.781 - 0.515 \log_e x$$

$$r^2 = 36.7$$

$$n = 659$$

$$F = 383.7$$

$$p < 0.001$$

For details of derivation of theoretical see section 1.2 (Fig 2). Body mass for theoretical equalled 150 g. Open symbols equal foraging birds, closed symbol equals non-foraging birds.

encounters m^{-1} - i.e. no intake recorded over duration of observation, birds which were apparently still foraging walked on average at only 68 cm.s^{-1} compared with $1.1 - 1.3 \text{ m.s}^{-1}$ in birds which were not foraging (e.g. aggressive chases).

Encounter rates with each prey type - small items, Macoma and worms were entered as separate independent variables in a multiple regression, with walking speed as the dependent variable (Table 24). Coefficients relating walking speed with each independent variable were not significantly different (Table 24).

(c) Other factors influencing walking speed

Mean walking speeds were calculated across short duration observations (above) in each plot (section 2.2) under different environmental conditions (air temperature, windspeed and hours since tidal emersion). Mean walking speed decreased non-linearly with increases in prey encounter rate (as above) and increased linearly with increasing time since tidal emersion. The variability explained by the two variables was only 10%. The large variability in mean walking speed appeared to be in part a result of consistent differences between plots related in turn to differences in substrate quality. Hence plot 3 at Culross (section 2.2 Fig. 6) which was relatively hard and sandy had consistently high walking speeds, whilst plot 11, thick deep mud, had consistently low walking speeds. Walking speeds at Skinflats (Fig. 5) were slightly faster than Culross (Fig. 6, section 2.2). Walking speeds were independent of temperature ($r = 0.035$), windspeed ($r = -0.023$) and Redshank density ($r = 0.04$).

(d) Walking speed and mud softness

There was a significant non-linear inverse relationship between walking speed (estimated by interpolating measured stride lengths on an

Table 24

Results of a multiple regression analysis of walking speed on encounter rate with each of the major prey (Hydrobia/Corophium = small items, Macoma, Worms) The coefficients of each independent variable were not significantly different from each other.

| Independent Variable log _e - encounter rate of | Coefficient | (σ) Coefficient | t |
|---|-------------|--------------------|--------|
| Small items | -0.419 | 0.029 | -16.75 |
| <u>Macoma</u> | -0 452 | 0 072 | - 6.23 |
| Worms | -0.363 | 0.10 | - 3 59 |
| Constant | -0 8213 | 0.04 | -23.13 |

n = 658

Analysis of variance.

| Source | SS | MS | F | p |
|---------------|---------|-------|--------|--------|
| Regression | 120.313 | 40 14 | 117 03 | < .001 |
| Small items | 94.25 | 94 25 | 274.78 | < 001 |
| <u>Macoma</u> | 21 63 | 21 63 | 63.06 | < 001 |
| Worms | 4 42 | 4 42 | 12 88 | < 001 |
| Residual | 224.52 | 0 343 | | |

Walking velocity
 m s^{-1}

Redshank

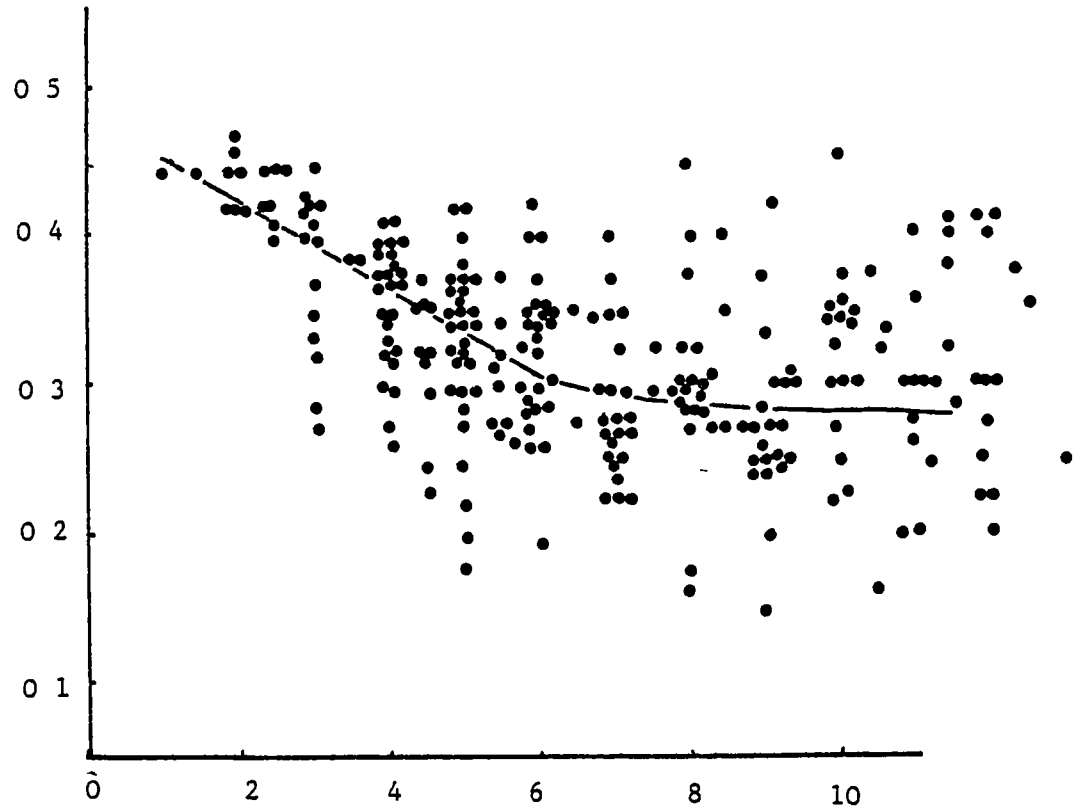

Mud softness
 depth of penetration of
 standard 50 g mass dropped
 from a constant height (cm)

Fig 61

Walking velocity of foraging Redshank against firmness of the substrate. Velocity predicted from measurements of stride length, interpolated on an empirical relationship (Fig 59). The curve describes the fitted regression equation

$$x (\text{m s}^{-1}) = 0.431 - 0.119 \log_e x + 1$$

$$r^2 = 27.6$$

$$F = 98.9$$

$$n = 255$$

$$p < 0.01$$

empirically derived relationship between stride length and walking speed - section 3.17) and mud softness (the penetration depth of a standard mass probe dropped from a constant height, adjacent to the measured stride) (Fig 61). In very soft muds (12 cm deep) Redshank walked at approximately 40% of the speed of Redshank on firm muds (2 cm deep).

(3.17.2) Redshank - visual versus tactile foraging

(a) Predicted changes in foraging mode

Theoretical gross and net energy gains, and protein gains for Redshank foraging both visually and in the tactile mode were predicted using an iterative calculation with successive inclusion of items of decreasing profitability (section 1.2) using the mean winter density across all plots at each site (section 2.2) at four air temperatures (0, 5, 10 and 15°C) and five different intervals since tidal emersion (0, 2, 4, 6 and 8 hours).

At both sites (Skinflats and Culross - section 2.2) under all conditions for both foraging methods, successive iterations initially resulted in increases in the dependent variable (gross or net energy gain, or protein gain) to a maximum, the theoretical maximum gain, and was then followed by decreases.

Variations in the theoretical maximum net and gross energy gains and protein gains - with air temperature and tidal cycle were almost identical. Changes in one of these - net energy gain, for both modes are plotted in Fig. 63 a and b, for Culross and Skinflats respectively (see section 2.2 for details of sites).

At both sites the theoretical maximum net energy gains whilst visually foraging increased with increases in temperature and decreased with increases in time since tidal emersion. Theoretical maximum gains whilst tactile foraging were comparatively independent of changes in both

Redshank - Culross

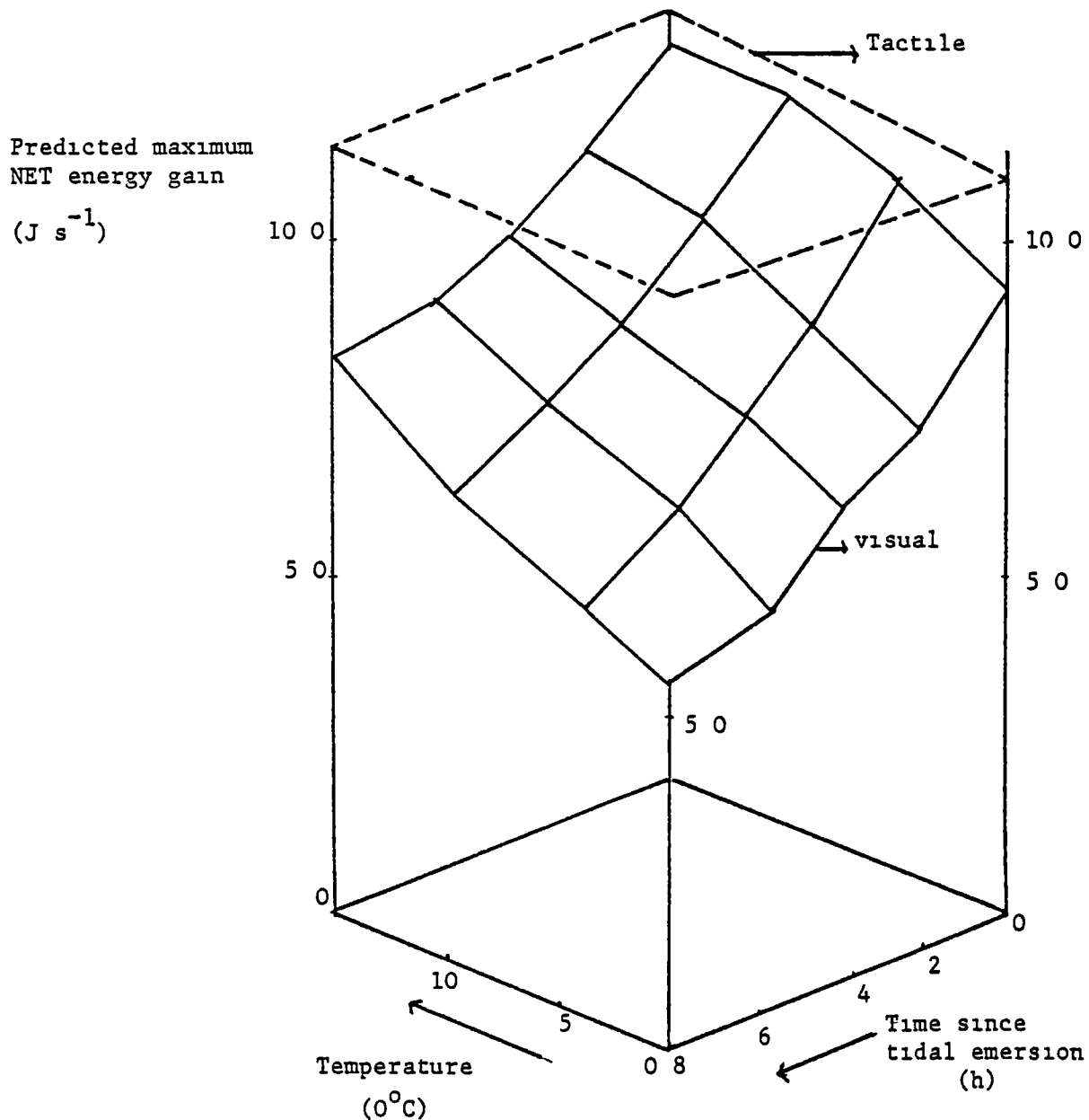

Fig 63a Predicted maximum net energy gains of Redshank when foraging visually (solid plane) or in the tactile mode (broken plane), at a fixed plot, against hours since tidal emersion and air temperature at Culross

Redshank - Skinflats

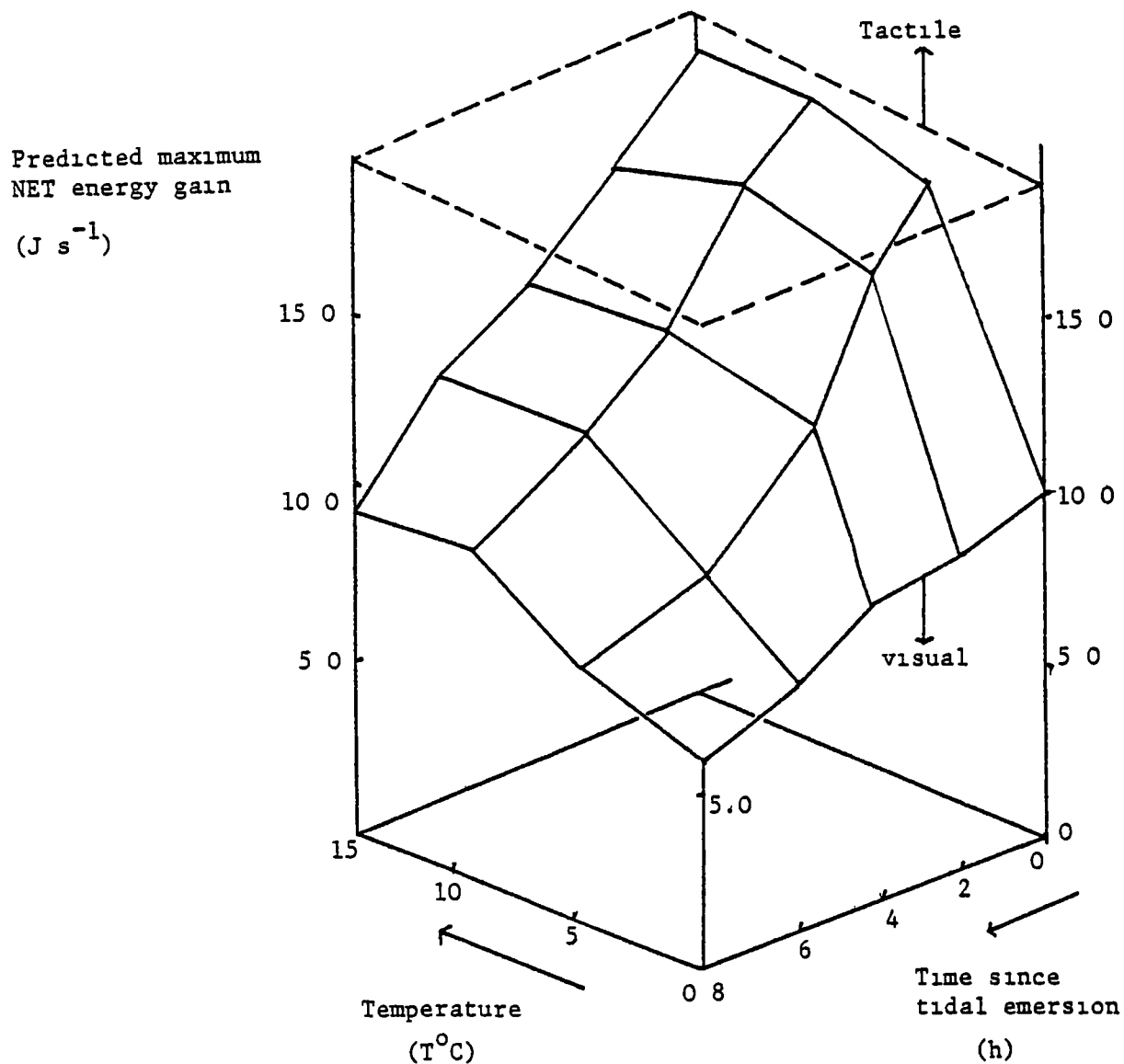

Fig 63b Predicted maximum net energy gains of Redshank when foraging visually (solid plane) or in the tactile mode (broken plane), at a fixed plot, against hours since tidal emersion and air temperature at Skinflats

temperature and time since tidal emersion, and exceeded the theoretical maximum gains when visually foraging under all conditions. Because fluctuations in the theoretical maximum gain were relatively greater in visual foragers the advantage of tactile foraging increased with time since tidal emersion and as air temperature decreased.

(b) Observed changes in foraging mode

The proportion of Redshank foraging visually or by the tactile method during a scan across all foraging individuals (see below for non-foraging) was independent of windspeed, air temperature and hours since tidal exposure at Skinflats, where on average 97.6% of birds fed visually. Only a single occurrence of more than 10% of the population foraging by tactile method was recorded at Skinflats when 20% of birds (total n = 70) switched from using the visual method to tactile foraging during and after a heavy storm which covered the mudflat with approximately 1 to 1.5 cm of water.

At Culross tactile foraging was more common (mean across all conditions = 91.3% visual). The proportion of the population tactile foraging was greatest on tidal emersion, or just behind the tide edge when on average 35% of birds fed in the tactile mode, and decreased throughout the period of tidal exposure (\log_e proportion visual foraging = $-0.434 + 0.229 \log_e$ hours exposed (+1), $r^2 = 22.4\%$, n = 63) (Fig. 64). The proportion of birds tactile foraging was independent of both temperature and windspeed at Culross.

(3.17.3) Redshank - foraging versus not foraging

(a) Predicted prey availability and environmental conditions under which it becomes unprofitable to forage

Equation 12 (section 1.2) predicts that an animal should stop foraging when its encounter rate with prey items falls below a critical

Redshank

Percentage feeding
visually

(%)

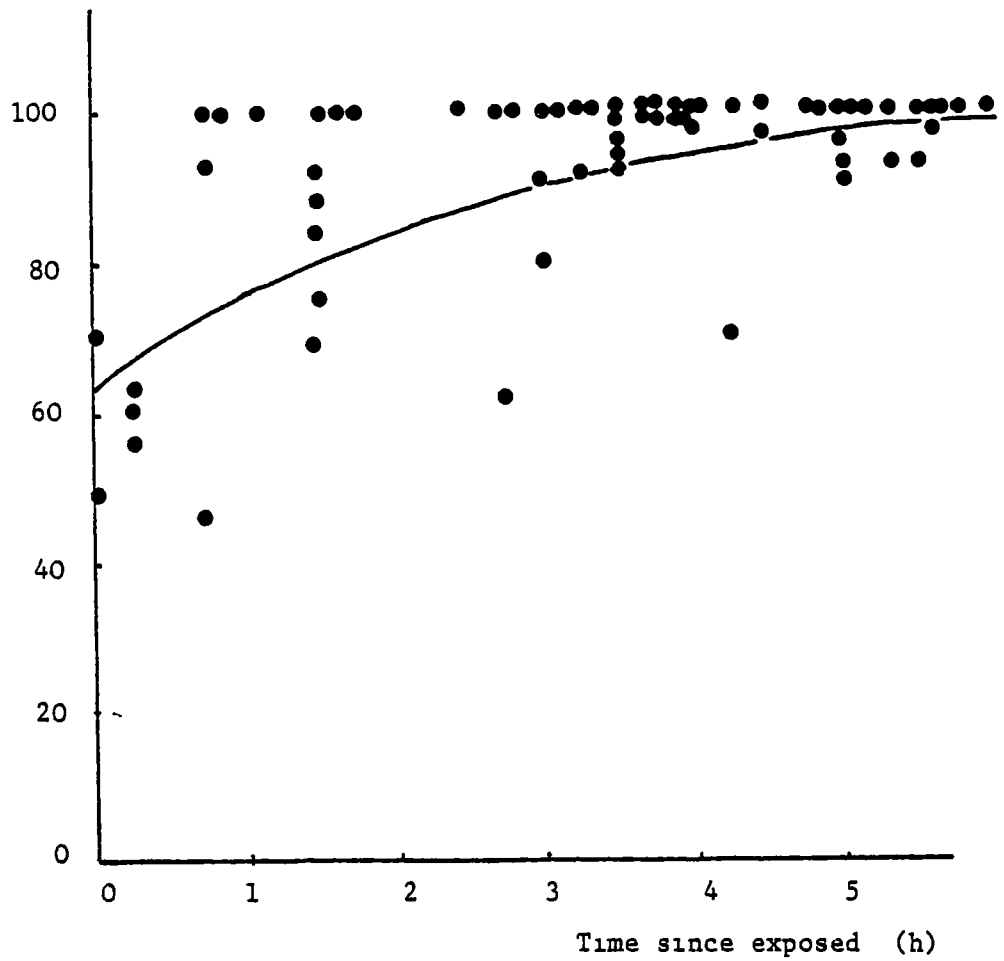

Fig 64

Percentage of Redshank feeding visually against the time since tidal emersion at Culross The curve describes the fitted regression equation

$$\log_e y = -0.434 + 0.229 \log_e (x + 1)$$

$$n = 63$$

$$r^2 = 22.4$$

$$F = 17.34$$

$$p < .001$$

value - $D_{a1CRIT} \cdot x$ Substituting the values from appropriate sections (above).

$$D_{a1CRIT} \cdot x = 8.31 \times 10^{-3} \text{ items.m}^{-1}$$

With an effective path width of 0.046 m (sections 3.9) this model predicts Redshank should stop foraging to conserve energy when the total prey availability across species falls below $0.21 \text{ items.m}^{-2}$.

Total prey availability, across species, was predicted against tidal exposure and air temperature using the empirically derived relationships between availability and environmental conditions (sections 3.8) and a mean Late Winter prey density estimate across all plots at each site (section 3.1).

Total availability decreased with decreases in air temperature and reached a minimum approximately eight hours after tidal emersion. Extrapolation of the relationship between prey availability and air temperature at the minimum point in the tidal cycle suggests the prey availability would fall below D_{a1CRIT} at approximately -30°C . Although this estimate is well below the lowest temperature at which data on availability and temperature were collected (-2°C), and may indeed be inaccurate if the relationship becomes non-linear below -2°C , clearly the conditions under which it becomes energetically profitable to stop foraging must be extremely severe.

(b) Observed foraging behaviour in severe conditions

Between the 6th and 26th December 1981 and between the 6th and 15th January 1982, were two periods of severe weather on the mid-estuarine Firth of Forth. Maximum daily air temperatures rarely exceeded 0°C in either period (Phizaklee, pers.comm.) and the stand-line at Skinflats was frozen. At air temperatures as low as -7°C throughout the cold spells, Redshank were observed, at both Skinflats and Culross, feeding as

Percentage of
Redshank
foraging

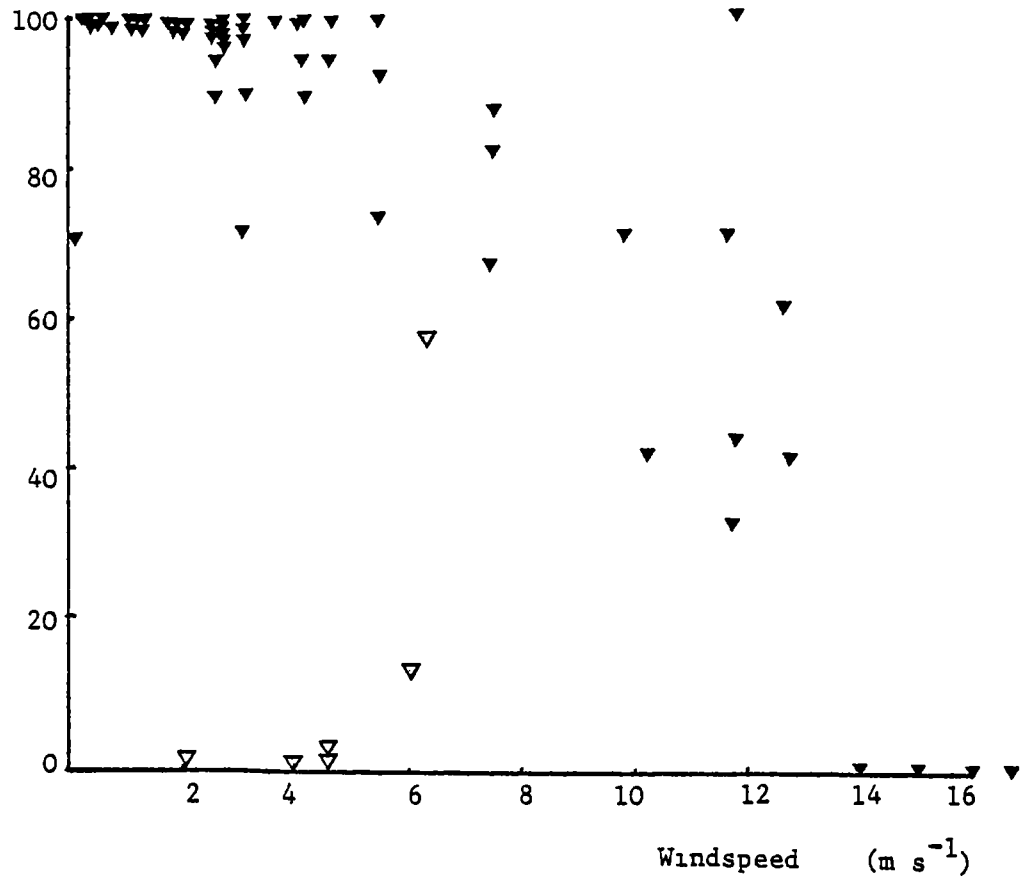

▼ no predator
▽ predator nearby

Fig 65 Percentage of Redshank observed foraging against windspeed in the presence and absence of an avian predator

normal over the low tide period - and none remained roosting.

(c) Non-foraging behaviour

Although Redshank continued to forage in severe conditions (above), Redshank were occasionally observed to stop foraging in much milder conditions. Non-foraging birds congregated around rocks, or in runnels where they mostly rested, but also occasionally roosted and preened. The proportion of birds not foraging increased in the presence of an avian predator (Peregrine falcon, Falco peregrinus, Kestrel, Falco tinnunculus and Sparrowhawk, Accipter nisus) (Fig 65). In the absence of predators an increasing proportion of Redshank stopped foraging with increases in windspeed (Fig. 65) ($r = -0.646$, $p < .01$, \log_e windspeed (+1) v Arcsin % foraging). There was also a much smaller but statistically significant inverse effect of temperature ($r = -0.245$, $p < .05$).

(3.17.4) Oystercatcher - visual searching, walking speed

(a) Predicted relationship between predator velocity (v) and prey encounter rate

The predicted relationship between predator walking speed (v) and prey encounter rate ($D_{ai}.x$) for a terrestrial predator of 500 g (see section 1.2) is shown in Fig. 66a.

(b) Observed relationship between predator walking speed and prey encounter rate

Oystercatchers must stop walking for all handling attempts - including false recognitions and false manipulations. Pacing rates were calculated from the number of paces and the interval between the termination of one handling attempt and initiation of the next. Pacing rates were converted to walking speeds using an empirical relationship

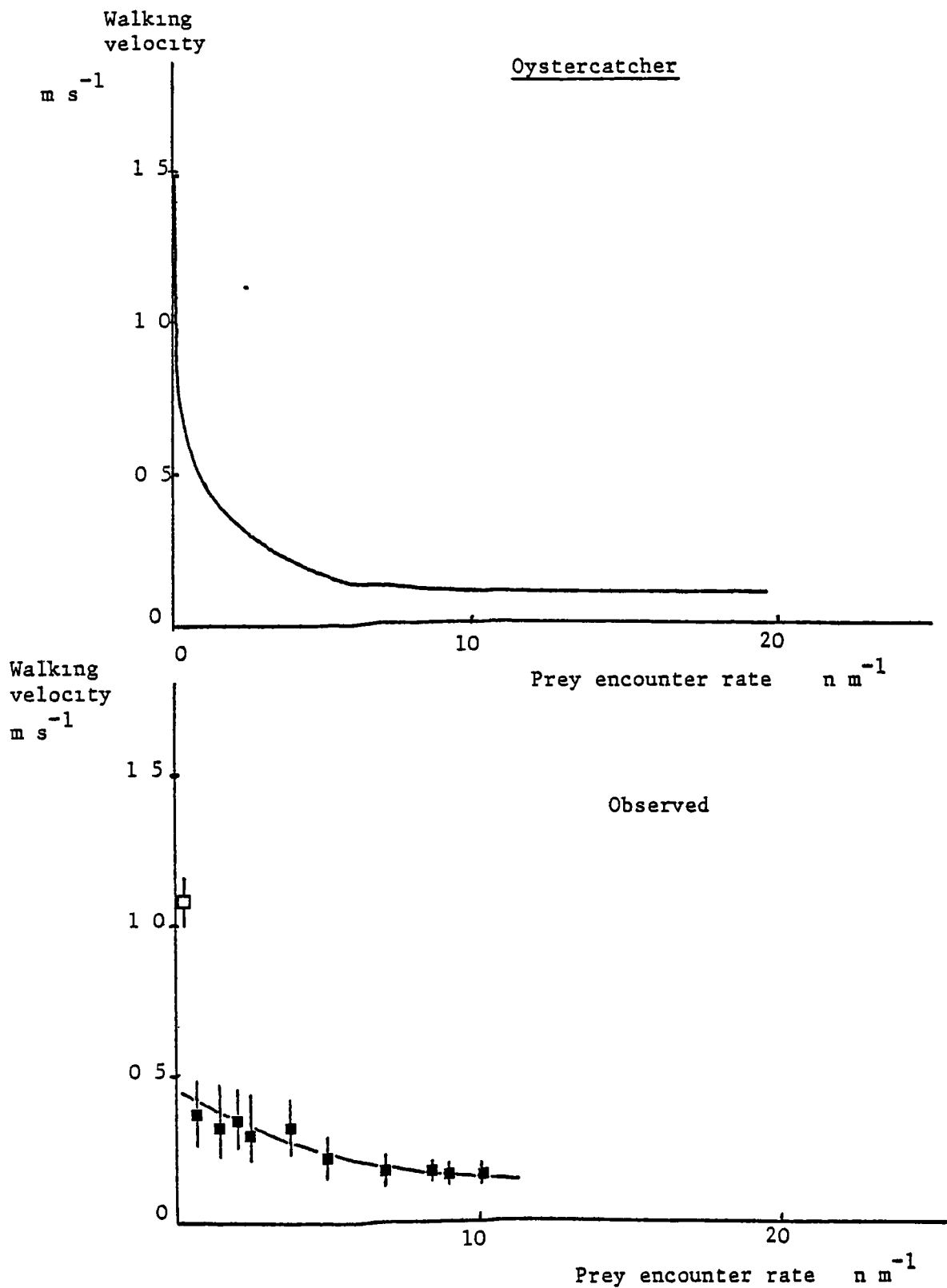

Fig 66

Theoretical and observed walking velocities against prey encounter rate ($n\ m^{-1}$ walked) in the Oystercatcher. Observed data pooled across plots and seasons. The curve in the lower graph equals the fitted regression equation

$$\log_e y = -1.3 + 0.169 \log_e x$$

$$r^2 = 0.171$$

$$n = 421$$

$$F = 91.67$$

$$p < .001$$

For details of derivation of the theoretical see section 1.2 (Fig 2). Body mass for theoretical equalled 500 g. Closed symbols equal foraging birds, open symbols equal non-foraging birds.

(section 3 17). Encounter rates were calculated as the reciprocal of the inter-attempt distance (= speed x time). Within each site there was an inverse non-linear relationship between predator walking speed and prey encounter rate. The pooled data across plots and outcome of the handling attempt are shown in Fig. 66b.

Predicted and observed walking speeds were not significantly different above encounter rates of 2 items.m⁻¹. At lower encounter rates the birds walked significantly slower than predicted by the acceleration limited model (section 1.2). The extrapolated estimate of walking speed at no encounters m⁻¹ equalled 38 - 40 cm.s⁻¹, only 34% of the walking speeds recorded in non-foraging birds (110 - 130 cm.s⁻¹).

Walking speeds were not significantly different between plots and were independent of the outcome of either the previous or succeeding handling attempt, temperature, windspeed and Oystercatcher density.

(3.17.5) Angularity of search path - Redshank

(a) Responses to prey availability

The angularity of Redshank search paths at a point A on the path, increased with increases in the mean surface availability of Hydrobia, adjacent to the path, previous to the point A. The significance of the relationship was dependent on the distance over which the availability estimate was made (Fig. 67). The only significant relationship (p < .01) occurred between angularities and mean availabilities estimated over the 50 cm immediately prior to point A.

(b) Responses to change in prey availability

The angularity of Redshank search paths at point A on the path increased with increases in Hydrobia availability previous to the point A. Increases in availability over the previous 1.5 and 4.5 m to point A had significant effects (p < 05) whilst changes in availability over all

Redshank

F value of regression
of path angularity on
prey availability

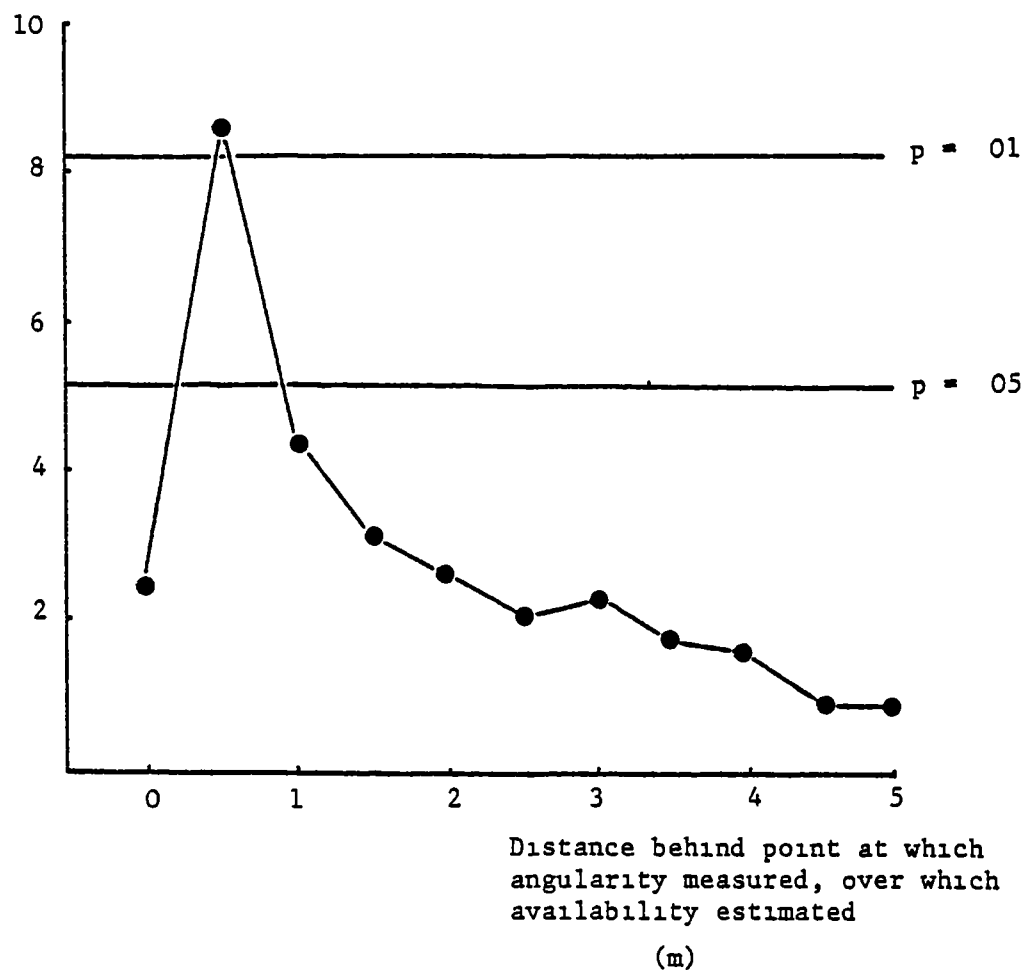

Fig 67 F values of regressions of Redshank foraging path angularity (see Fig 10), measured at a point x on a foraging path, on availability of Hydrobia ulvae along the path prior to x, against the distance over which the availability estimate was made

F value of regression
of path angularity on
change in prey
availability

Redshank

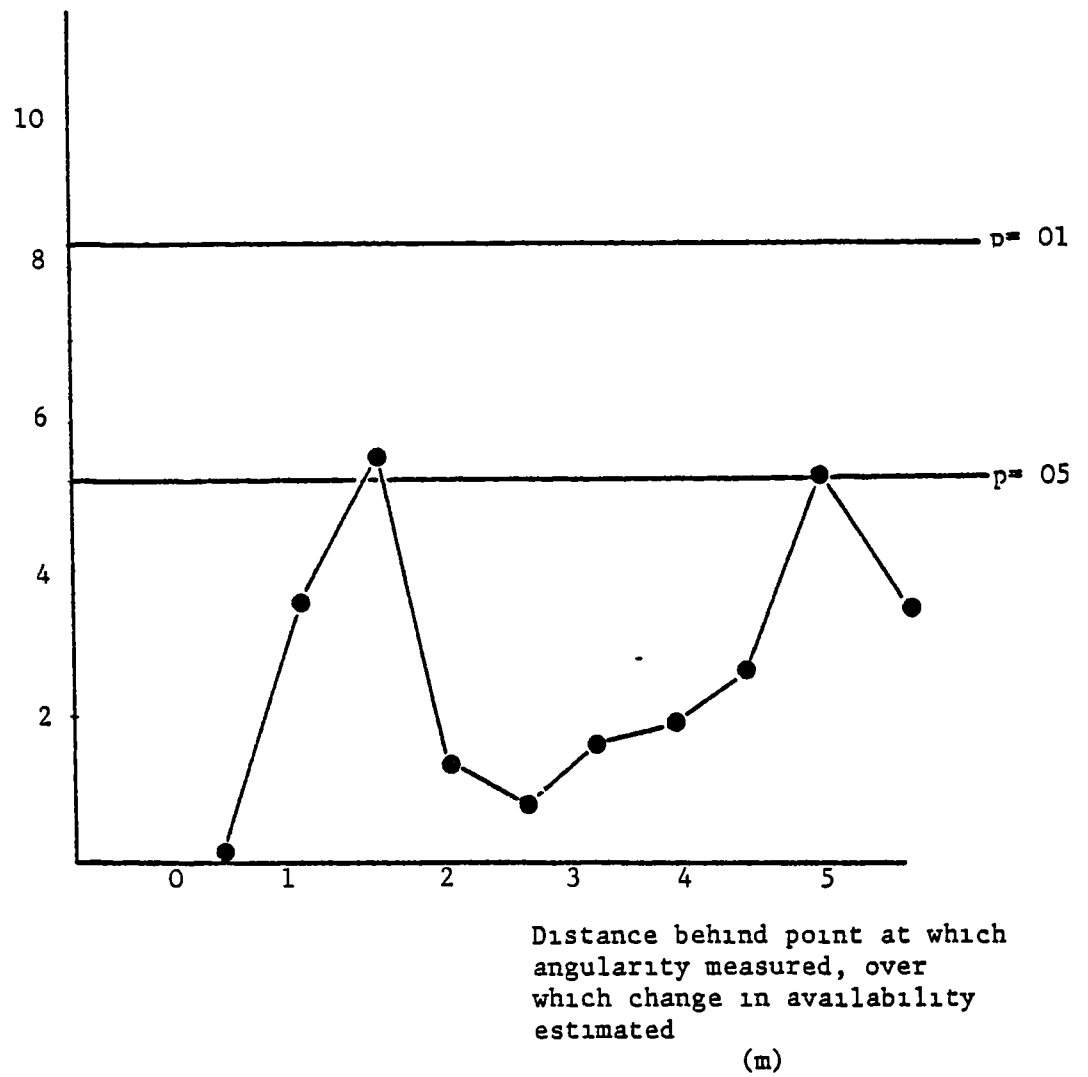

Fig 68

F values of regressions of Redshank foraging path angularity (see Fig 10) measured at a point x on a foraging path, on change in availability of Hydrobia ulvae along the path prior to x, against the distance over which the change in availability estimate was made. Change in availability was estimated as availability estimate over the half of distance nearest to x minus the estimated availability over the half furthest from x

Intensity of
pattern

Hydrobia ulvae

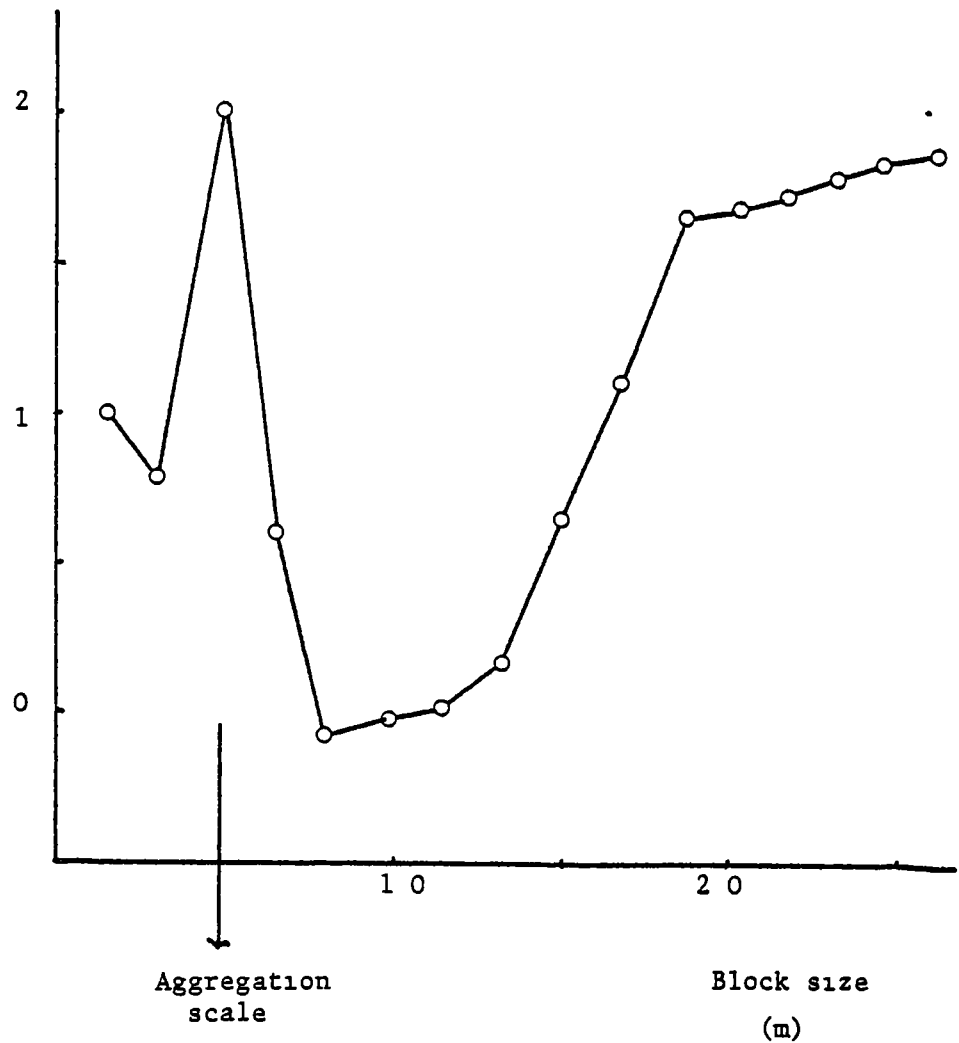

Fig 69 Intensity of pattern, from a two-term covariance analysis (Hill (1977)) against block size, in Hydrobia ulvae, (Spring 1982, Skinflats) Significant aggregation (denoted by a sharp peak) occurred only on a scale of 50 cm

other distances were not significant (Fig 68)

Angularity at point A was entered as the dependent variable in a stepwise multiple regression with availability over the previous 0.5 m and changes in availability over the previous 1.5 and 4.5m to point A as independent variables. Angularity was significantly ($p < .001$) and positively related to the availability of Hydrobia over the previous 0.5 m (Fig. 68). Neither of the other independent variables attained significance of $p < .025$ and were eliminated.

(c) The scale of pattern in surface Hydrobia

Intensity of aggregation in surface Hydrobia from a Hill's two-term covariance analysis (Hill 1977) against block width (cm) is shown in Fig. 69. Peaks in the intensity reflect significant clumping of Hydrobia, and only occurred over a scale of 50 cm. It can therefore be concluded that patches of Hydrobia were approximately 50 cm wide.

(3.18) Diet Choice - Redshank

(3.18.1) Hypothesis and alternative hypotheses

Predictions of diet choice in Redshank were made using four models, based on the following hypotheses - maximization of gross and net energy gain, gross protein gain, and random selection.

(a) Maximization of net energy gain

Prey types (species and size class) were separated in order of their net energy profitability (P_i - equation 1, section 1.2). Net energy gains were calculated for inclusion of the most profitable item (equation 9), with the predator velocity v_i calculated from the empirical relationship between walking speed and encounter rate (section 3.17.1). The item of next greatest profitability was included if its profitability satisfied inequality 27 (or 28, or 29 - depending on the predator

velocity). If included, net energy gains were recalculated with inclusion (equation 24). This iterative procedure continued for inclusion of all prey, until the item of greatest profitability from those items not included in the diet did not satisfy the appropriate inequality (27, 28 or 29) at the given predator velocity.

Diet choice was predicted as inclusion of all items of greater profitability than the first item not satisfying the appropriate inequality.

(b) Maximization of gross energy gain

Items (i) were ranked in order of gross profitability (P_{gi})

$$P_{gi} = \frac{E_i}{T_{ti}} \quad (32)$$

Gross energy gain (E_g) was calculated for inclusion of the most profitable item.

$$E_{gi} = \frac{E_{ti} \cdot D_i \cdot P_{ai} \cdot P_{di} \cdot P_{c1}}{T_{ti} \cdot D_i \cdot P_{ai} \cdot P_{di} \cdot P_{c1} + 1/v_i} \quad (33)$$

(see section 1.2 for details of symbols)

The prey type of greatest profitability from those remaining was included if it satisfied the inequality

$$P_{gi} > E_{gi} \quad (34)$$

If the item was included E_g was recalculated and the iterative procedure was repeated until the item of next greatest profitability did not satisfy inequality 34. The predicted diet was inclusion of all items of greater profitability than the first item not satisfying

inequality 34.

(c) Maximization of gross protein gain

The procedure adopted was identical to that adopted to calculate the diet under the hypothesis of Gross Energy Maximization (above) with Gross assimilable protein content (P_{pi}) substituted for the Gross assimilable energy content.

(d) Random selection

Although a bird pecking at random is more likely to make contact with a large item because of its larger size, the small sizes of Redshank prey mean that, even at very high availabilities, the area of mud occluded by prey is only a small fraction of the total surface. For example, a population of 10,000 Hydrobia m^{-2} of 3 mm length (Appendix 1) would occupy only approximately 4.5% of the mud surface area. Because availabilities seldom approach 10,000 m^{-2} , a Redshank pecking at random would experience a very high failure rate. This was not observed (section 3.13). Pecks must therefore be directed at prey, or features on the mud surface resembling prey items. A 'random' prediction was made assuming the birds selected indiscriminately every prey item encountered.

(3 18.2) Spatial and temporal variation in profitability

(a) Hydrobia ulvae

(i) Gross energy profitability (P_{gi}) and Gross protein profitability (P_{pi})

In all seasons, at Culross and Skinflats, on flow and ebb tides, there was a significant positive and curvilinear relationship between both the P_{gi} and P_{pi} , and body length (Appendix 1). Variations of both P_{gi} and P_{pi} of Hydrobia of shell lengths 1.0, 2.0, 3.0 and 4.0 mm with season, site and tidal cycle are shown in Table 25 The major

factor influencing P_{gi} was body length. The largest Hydrobia (4.0 mm) were on average 22.2x more profitable than the smallest (1.0 mm). Season was the second most important factor. P_{gi} 's were greatest in Autumn, and lowest in Late Winter (section 2.3) across all sizes. On average, the profitability in Late Winter was 40% of that in Autumn. Profitabilities in Spring and Early Winter were intermediate.

Differences between sites (section 2.2) and between flow and ebb tides (section 3.13.1) were relatively smaller. On average P_{gi} was 25% greater at Skinflats, and 7% greater on the ebb tide, compared with the flow tide.

In combination the effects of season, site and tide had a large effect on the P_{gi} of a given size of Hydrobia. The P_{gi} of 4.0 mm Hydrobia varied between 124.13 J s^{-1} handling (Skinflats, Autumn, ebb tide) and 56.32 J.s^{-1} handling (Culross, Late Winter, flow tide). Variations in P_{pi} followed a similar pattern (Table 25).

(ii) Net energy profitability (P_i)

Because energy expenditure whilst handling prey is dependent upon ambient temperature, windspeed and body mass of the Redshank (sections 3.14 - 3.16) P_i 's were calculated using the mean daily maximum air temperature (Phizacklea - pers. comm.), and mean body mass of Redshank (Minton 1975) in each season. Windspeeds were set equal to 0 m s^{-1} .

There was a significant positive curvilinear relationship between P_i and body length in all seasons, at Skinflats and Culross, on ebb and flow tides. In the largest Hydrobia (4.0 mm) the effects of including energy costs on profitability were negligible, on average the P_i was 98% of the P_{gi} . In smaller Hydrobia the effects of costs were relatively much greater, and in the smallest (1.0 mm) Hydrobia in Late Winter, P_i was negative. Whilst handling the majority of Hydrobia

Table 25

Gross (P_{gi}), Net (P_i) and Protein (P_{pi}) profitabilities of four size classes of Hydrobia ulvae, across season, site and stage of tidal cycle.

| Season/Site | Tide | Shell length (mm) | | | | | | | | | | | |
|--------------|------|-------------------|-------|----------|----------|-------|----------|----------|-------|----------|----------|-------|----------|
| | | 1.0 | | | 2.0 | | | 3.0 | | | 4.0 | | |
| | | P_{gi} | P_i | P_{pi} | P_{gi} | P_i | P_{pi} | P_{gi} | P_i | P_{pi} | P_{gi} | P_i | P_{pi} |
| Autumn | | | | | | | | | | | | | |
| Skinflats | Ebb | 5.9 | 3.7 | - | 27.0 | 24.8 | - | 65.9 | 63.7 | - | 124.1 | 121.9 | - |
| | Flow | 5.5 | 3.3 | - | 25.1 | 22.9 | - | 61.7 | 59.5 | - | 116.3 | 114.1 | - |
| Culcross | Ebb | 4.3 | 2.1 | - | 19.7 | 17.5 | - | 48.0 | 45.8 | - | 90.4 | 89.2 | - |
| | Flow | 4.0 | 1.8 | - | 18.4 | 16.2 | - | 45.0 | 42.8 | - | 84.7 | 82.5 | - |
| Early Winter | | | | | | | | | | | | | |
| Skinflats | Ebb | 5.9 | 3.1 | 0.046 | 21.7 | 18.9 | 0.18 | 46.4 | 43.6 | 0.38 | 79.8 | 77.0 | 0.66 |
| | Flow | 5.5 | 2.7 | 0.046 | 20.3 | 17.5 | 0.16 | 43.5 | 40.7 | 0.36 | 74.7 | 71.9 | 0.62 |
| Culcross | Ebb | 4.4 | 1.6 | 0.036 | 16.3 | 13.5 | 0.14 | 35.0 | 32.2 | 0.29 | 60.1 | 57.30 | 0.50 |
| | Flow | 4.1 | 1.3 | 0.034 | 15.3 | 12.5 | 0.13 | 32.8 | 30.0 | 0.27 | 56.3 | 53.5 | 0.47 |
| Late Winter | | | | | | | | | | | | | |
| Skinflats | Ebb | 2.2 | -1.0 | 0.02 | 7.3 | 4.1 | 0.06 | 24.1 | 20.9 | 0.20 | 79.1 | 75.9 | 0.66 |
| | Flow | 2.1 | -1.1 | 0.02 | 6.9 | 3.7 | 0.06 | 22.6 | 19.4 | 0.19 | 74.1 | 70.9 | 0.61 |
| Culcross | Ebb | 1.7 | -1.5 | 0.014 | 5.7 | 2.5 | 0.05 | 18.6 | 15.4 | 0.16 | 61.2 | 58.0 | 0.51 |
| | Flow | 1.6 | -1.6 | 0.014 | 5.3 | 2.1 | 0.04 | 17.5 | 14.3 | 0.14 | 57.4 | 54.2 | 0.48 |
| Spring | | | | | | | | | | | | | |
| Skinflats | Ebb | 2.9 | 0.1 | - | 16.6 | 13.8 | - | 45.6 | 42.8 | - | 93.6 | 90.4 | - |
| | Flow | 2.7 | -0.1 | - | 15.5 | 12.7 | - | 42.7 | 39.9 | - | 87.7 | 84.5 | - |
| Culcross | Ebb | 2.3 | -0.5 | - | 12.8 | 10.0 | - | 35.3 | 32.5 | - | 72.4 | 69.2 | - |
| | Flow | 2.1 | -0.7 | - | 12.0 | 9.2 | - | 33.1 | 30.3 | - | 67.9 | 64.7 | - |

P_{gi} and P_i - $J.s^{-1}$ P_{pi} - mg protein. s^{-1}

however, energy gains exceeded energy costs by between 10 and 100x.

(b) Corophium volutator

(i) Gross energy profitability (P_{gi}) and Gross protein profitability (P_{pi})

In all seasons (section 2.3) there was a significant positive, curvilinear, relationship between both the P_{gi} and P_{pi} and body length. The effects of body length, season and tidal cycle on P_{gi} and P_{pi} in Corophium are summarised in Table 26

Body length was the most important factor influencing both P_{gi} and P_{pi} . On average the largest Corophium (8.0 mm) varied between 5 and 20x more profitable than the smallest (2.0 mm). Seasonal variation in profitability was also important. On average the greatest profitability was found in Autumn and it declined throughout the Winter to a minimum in Spring. This decline was most marked in the smaller classes where on average in Spring the profitability was only 10 - 20% of that in Autumn. In the larger classes Spring profitability averaged 52% of the Autumn profitability. Differences between ebb and flow tides were less significant, the flow tide profitability was on average 7% lower than on ebb tides (section 3.13 1).

(ii) Net energy profitabilities (P_i)

Net profitabilities were calculated as in Hydrobia (section 3 18.2(a)) There was a significant positive, curvilinear relationship between net profitability and body length in all seasons on both ebb and flow tides. In large Corophium (6 - 8 mm) the effects of including costs on profitability were negligible. On average, the net profitability was 95% of the gross profitability in the largest class. In smaller classes the effects were much greater. The net profitability of the smallest Corophium (1 mm) was negative in all seasons except

Table 26

Gross (P_{gi}), Net (P_i) and Protein (P_{pi}) profitabilities of four size classes of Corophium volutator, across season and stage of the tidal cycle

| Season/Site | Tide | Body length (mm) | | | | | | | | | | | |
|--------------|-----------|------------------|-------|----------|----------|-------|----------|----------|-------|----------|----------|-------|----------|
| | | 0.5 | | 2.5 | | 4.5 | | 6.5 | | | | | |
| | | P_{gi} | P_i | P_{pi} | P_{gi} | P_i | P_{pi} | P_{gi} | P_i | P_{pi} | P_{gi} | P_i | P_{pi} |
| Autumn | | | | | | | | | | | | | |
| | Skinflats | 5.3 | 3.0 | - | 26.0 | 23.7 | - | 46.5 | 44.2 | - | 66.9 | 64.6 | - |
| | Flow | 4.9 | 2.6 | - | 24.5 | 22.2 | - | 43.8 | 41.5 | - | 63.0 | 60.7 | - |
| Early Winter | | | | | | | | | | | | | |
| | Skinflats | 0.5 | -2.3 | 0.01 | 9.6 | 6.8 | 0.19 | 28.3 | 25.5 | 0.68 | 55.6 | 52.8 | 1.11 |
| | Flow | 0.5 | -2.3 | 0.01 | 9.1 | 6.3 | 0.22 | 26.7 | 23.9 | 0.65 | 52.3 | 49.5 | 1.07 |
| Late Winter | | | | | | | | | | | | | |
| | Skinflats | 0.5 | -2.6 | 0.01 | 9.5 | 6.3 | 0.19 | 27.9 | 24.6 | 0.67 | 54.7 | 51.5 | 1.32 |
| | Flow | 0.5 | -2.6 | 0.01 | 8.9 | 5.7 | 0.21 | 26.3 | 23.1 | 0.64 | 51.4 | 48.2 | 1.27 |
| Spring | | | | | | | | | | | | | |
| | Skinflats | 0.6 | -2.2 | - | 7.3 | 4.5 | - | 18.9 | 16.1 | - | 34.1 | 31.3 | - |
| | Flow | 0.5 | -2.1 | - | 6.9 | 4.1 | - | 17.8 | 15.0 | - | 32.1 | 29.3 | - |

P_{gi} and P_i - $J s^{-1}$ P_{pi} - mg protein. s^{-1}

Autumn. As with Hydrobia whilst handling most Corophium (>2 mm long) gains exceeded costs by 10 - 50x.

(c) Macoma Balthica

(i) Gross energy profitability (P_{gi}) and Gross protein profitability (P_{pi})

P_{gi} and P_{pi} in Macoma showed a peaked relationship with body width (e.g. Fig. 70). In all seasons, under all conditions, except Late Winter, the peak profitability occurred at a shell width (Appendix 1) of 10 mm. In Late Winter the peak occurred at 8 mm. Mean profitabilities were calculated across the size classes used in field observations (section 2.17). The effects of season, site and state of the tidal cycle on P_{gi} and P_{pi} for each size class are summarized in Table 27.

Across all conditions medium sized Macoma had the greatest P_{gi} and P_{pi} . Seasonal variability was different in each class. Small Macoma increased in P_{pi} and P_{gi} between Autumn and Late Winter and subsequently declined, whilst medium and large individuals had relatively stable profitabilities throughout the Winter and increased in Spring. Variability was greatest in the small class where the maximum exceeded the minimum by 2.45x, compared with 1.2x and 1.8x in medium and large Macoma respectively.

Profitabilities were greater on ebb tides than flow tides. Ebb profitabilities varied between 1.17 and 1.33x the flow profitabilities. Differences between Skinflats and Culross were relatively small and never exceeded 10%.

(ii) Net energy profitability (P_i)

The difference between P_i and P_{gi} varied with size. The effects on profitability of including costs in all three classes were relatively small. Across all conditions P_i averaged 84, 92 and 83% of

Gross Energy
profitability

$J s^{-1}$

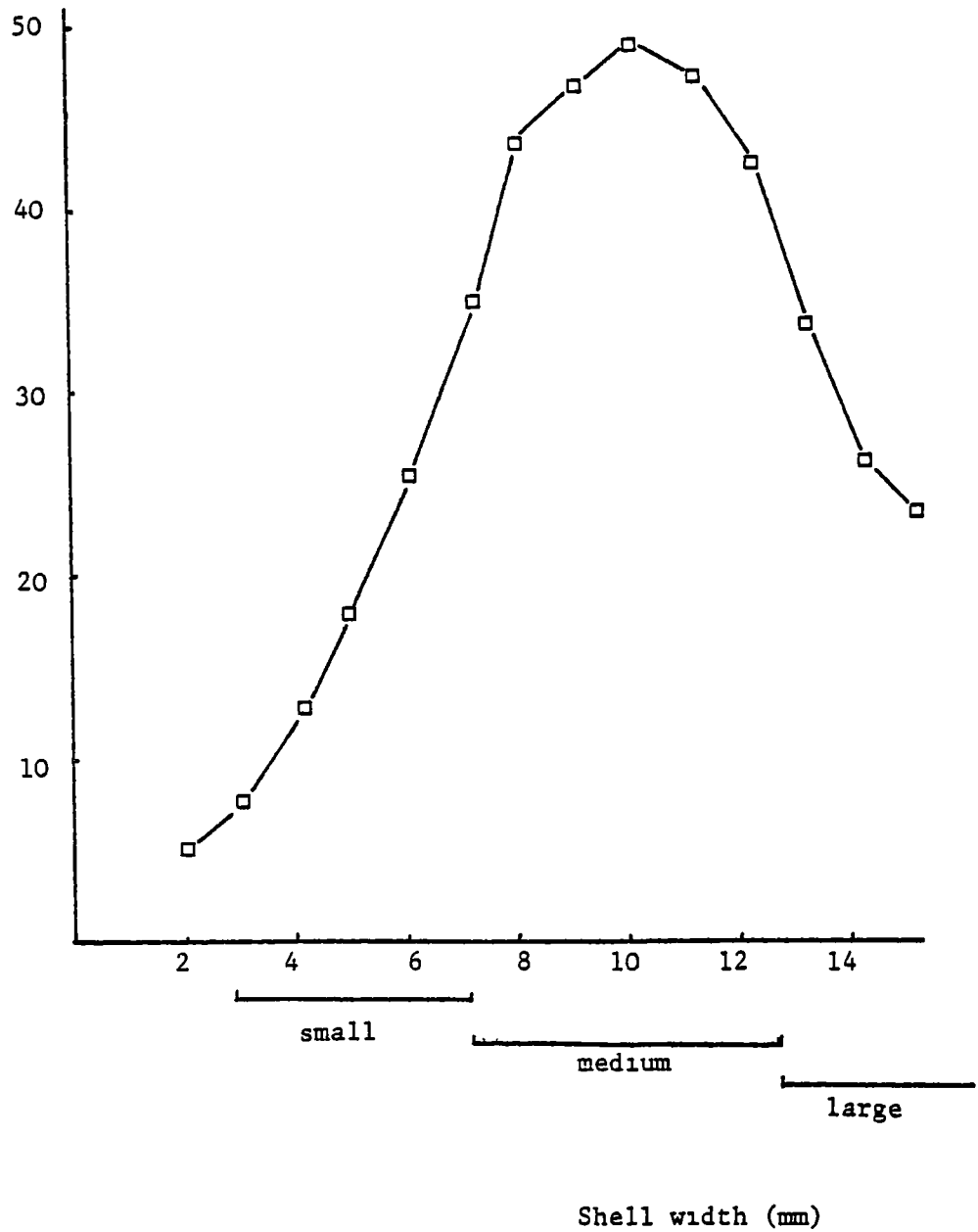

Fig 70

Gross energy profitability of Macoma balthica (P_{g1}) - eqn 32, against shell width. Ranges of Macoma included in the observational classes are shown. Example equals ebb tide, Culross, Early Winter

Table 27

Gross (P_{gl}) and net energy profitability (P_i) and gross protein profitability (P_{pi}) of three size classes of Macoma balthica against season, site, and stage of the tidal cycle.

| Season | Site | Tide | small 0.26 - 0.75 | | | medium 0.76 - 1.25 cm | | | Large 1.26 cm | | |
|--------------|------|------|----------------------|-------------------|-----------------------|--------------------------|-------------------|-----------------------|----------------------|-------------------|-----------------------|
| | | | P_{gl}^{-1} J.s | P_i^{-1} J.s | P_{pi}^{-1} mg.s | P_{gl}^{-1} J.s | P_i^{-1} J.s | P_{pi}^{-1} mg.s | P_{gl}^{-1} J.s | P_i^{-1} J.s | P_{pi}^{-1} mg.s |
| Autumn | S | Ebb | 22.1 | 19.9 | - | 37.8 | 35.6 | - | 14.7 | 12.5 | - |
| | | Flow | 16.4 | 14.2 | - | 31.9 | 29.7 | - | 18.7 | 11.5 | - |
| | C | Ebb | 24.3 | 22.1 | - | 41.5 | 39.3 | - | 16.2 | 14.0 | - |
| | | Flow | 18.0 | 15.8 | - | 35.1 | 32.9 | - | 15.6 | 13.4 | - |
| Early Winter | S | Ebb | 19.7 | 17.1 | 0.27 | 38.4 | 35.8 | 0.53 | 16.3 | 13.7 | 0.22 |
| | | Flow | 14.7 | 12.1 | 0.20 | 32.4 | 29.8 | 0.45 | 15.6 | 13.0 | 0.22 |
| | C | Ebb | 21.7 | 19.1 | 0.33 | 42.1 | 39.5 | 0.63 | 17.9 | 15.3 | 0.27 |
| | | Flow | 16.1 | 13.5 | 0.24 | 35.6 | 33.0 | 0.50 | 17.2 | 15.6 | 0.26 |
| Late Winter | S | Ebb | 36.4 | 33.1 | 0.49 | 45.0 | 41.7 | 0.61 | 14.4 | 11.1 | 0.19 |
| | | Flow | 26.9 | 23.6 | 0.36 | 37.8 | 34.5 | 0.46 | 13.4 | 10.1 | 0.18 |
| | C | Ebb | 34.1 | 31.8 | 0.58 | 42.2 | 38.9 | 0.72 | 13.5 | 10.2 | 0.23 |
| | | Flow | 25.2 | 21.9 | 0.43 | 35.5 | 32.2 | 0.61 | 13.0 | 9.7 | 0.22 |
| Spring | S | Ebb | 14.8 | 12.2 | - | 45.5 | 42.9 | - | 26.1 | 23.5 | - |
| | | Flow | 11.1 | 8.5 | - | 38.7 | 36.1 | - | 25.1 | 22.5 | - |
| | C | Ebb | 13.9 | 11.3 | - | 42.6 | 40.0 | - | 24.5 | 21.9 | - |
| | | Flow | 10.4 | 6.8 | - | 36.2 | 33.6 | - | 23.5 | 20.9 | - |

Note - No protein contents available for Autumn and Spring.

the P_{gi} in small, medium and large Macoma respectively. P_i 's were negative in only the very smallest Macoma (< 5 mm.).

(d) Polychaetes

(i) Gross energy profitability (P_{gi}) and Gross protein profitability (P_{pi})

There was a non-linear positive relationship between both P_{gi} and P_{pi} and body length (Appendix 1) in all seasons. The mean profitabilities across each size class used in the field observations (section 2.5) are summarized in Table 28. Across seasons, large worms (class 4) were on average 8x more profitable than small worms (class 1). Seasonal variations were relatively unimportant.

(ii) Net energy profitability (P_i)

Costs were of little importance in the profitabilities of all polychaetes. Even in small worms (class 1) P_i always exceeded 85% of the P_{gi} , whilst in large worms (class 4) P_i always exceeded 98.5% of the P_{gi} .

(3.18.3) Comparison of profitabilities across prey types

(a) Gross and net energy profitabilities (P_{gi} and P_i)

Variations in P_{gi} and P_i with season, site and tidal cycle were similar. Ranges of P_{gi} across all these variables for selected size classes of each prey type, covering the whole range of profitabilities within each prey are shown in Fig. 71.

The range of profitabilities within each prey species was very large, the ranges for Macoma and Corophium overlapped completely the range for Hydrobia. Large worms (classes 3 and 4) were consistently the most profitable prey, and always had profitabilities in excess of 100 $J.s^{-1}$ handling. Large (>3.5 mm) Hydrobia and Corophium (>7 mm) with medium sized worms (class 2) formed a second group with profitabilities

Table 28

Gross (P_{gi}) and net energy profitability (P_i) and gross protein profitability (P_{pi}) of four size classes of Worms against season, site and stage of the tidal cycle

| Season | Size Class | | | | | | | | | | | |
|--------------|------------------------|---------------------|-------------------------|------------------------|---------------------|-------------------------|------------------------|---------------------|-------------------------|------------------------|---------------------|-------------------------|
| | 1 | | 2 | | 3 | | 4 | | | | | |
| | P_{gi} $J s^{-1}$ | P_i $J s^{-1}$ | P_{pi} $mg s^{-1}$ | P_{gi} $J s^{-1}$ | P_i $J s^{-1}$ | P_{pi} $mg s^{-1}$ | P_{gi} $J s^{-1}$ | P_i $J s^{-1}$ | P_{pi} $mg s^{-1}$ | P_{gi} $J s^{-1}$ | P_i $J s^{-1}$ | P_{pi} $mg s^{-1}$ |
| Autumn | 27.8 | 25.6 | 0.51 | 65.2 | 63.0 | 1.24 | 106.4 | 104.2 | 2.1 | 151.2 | 149.0 | 3.0 |
| Early Winter | 22.4 | 19.8 | 0.44 | 73.3 | 70.7 | 1.44 | 147.6 | 145.0 | 2.91 | 244.5 | 241.9 | 4.83 |
| Late Winter | 23.8 | 20.5 | 0.47 | 60.6 | 57.3 | 1.19 | 104.1 | 100.8 | 2.06 | 183.6 | 150.3 | 3.04 |
| Spring | 16.5 | 13.9 | 0.32 | 52.3 | 49.7 | 1.03 | 102.9 | 100.3 | 2.03 | 167.6 | 165.0 | 3.31 |

Note Size classes equal

- 1 3 - 19 mm
- 2 20 - 35 mm
- 3 36 - 58 mm
- 4 > 59 mm

Gross energy profitability
 (P_{g1}) with range
 $J s^{-1}$

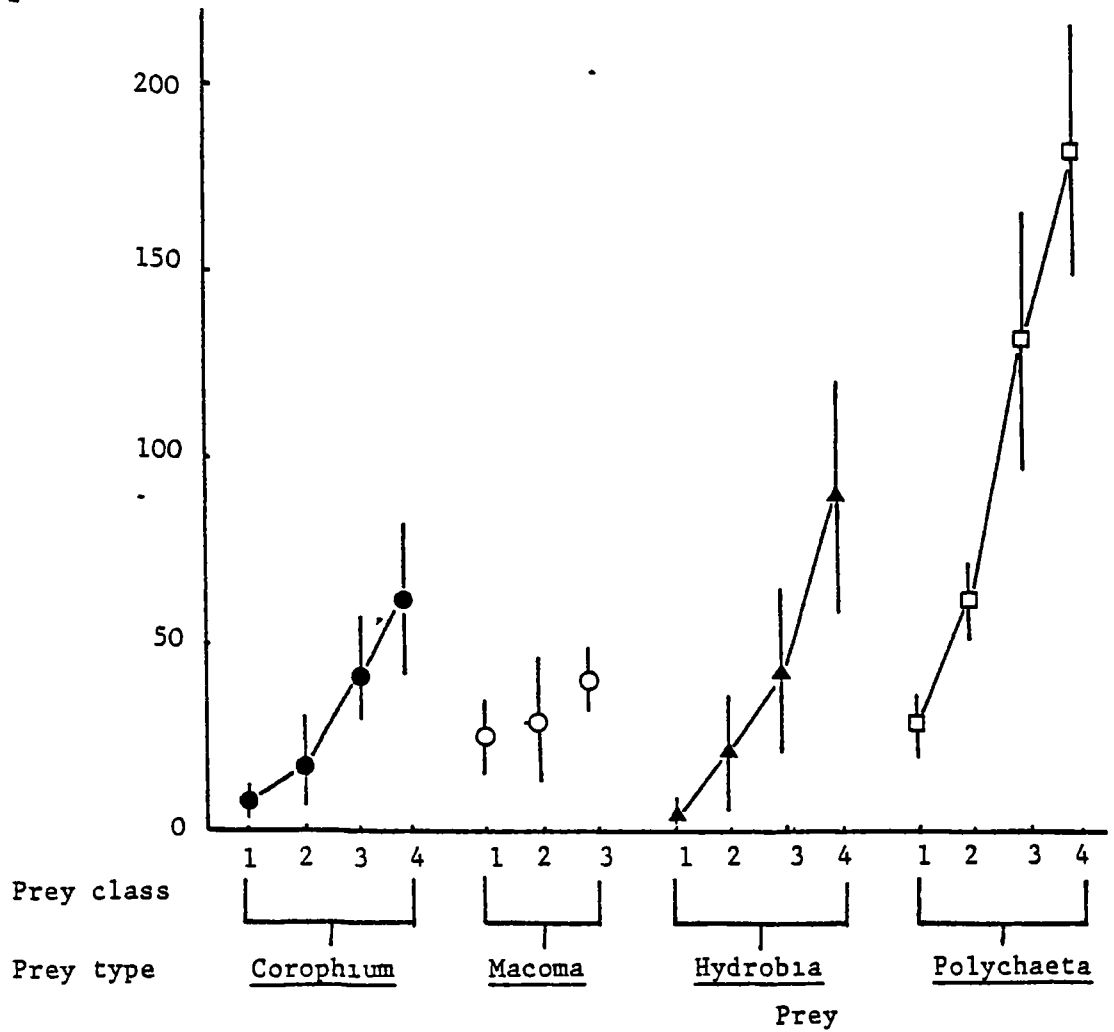

Fig 71 Gross energy profitabilities of all Redshank prey, with ranges for each class across all conditions The size classes are as follows

| | class | size (body length) | | class | size (body length) |
|------------------|-------|--------------------|-------------------|-------|-----------------------|
| <u>Corophium</u> | 1 | 2 mm | <u>Macoma</u> | 1 | 1.26 cm - large |
| | 2 | 4 mm | | 2 | 0.26-0.75 cm - small |
| | 3 | 6 mm | | 3 | 0.76-1.25 cm - medium |
| | 4 | 8 mm | | | |
| <u>Hydrobia</u> | 1 | 1 mm | <u>Polychaeta</u> | 1 | 8 - 19 mm |
| | 2 | 2 mm | | 2 | 19.1 - 35 mm |
| | 3 | 3 mm | | 3 | 35.1 - 58 mm |
| | 4 | 4 mm | | 4 | > 58 mm |

Gross Protein Profitability
 (P_{p1}) with range
 mg s^{-1}

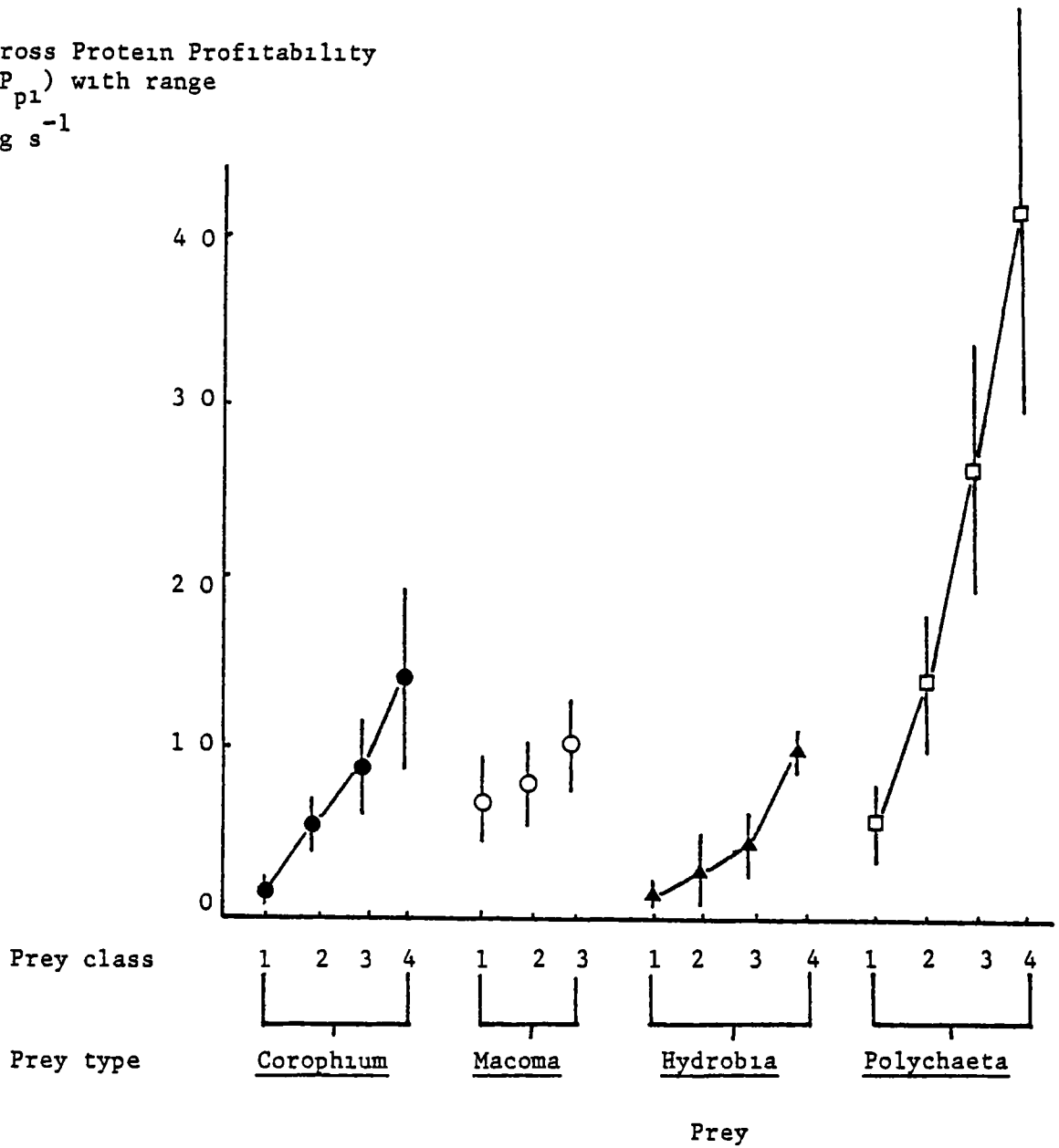

Fig 72 Gross protein profitabilities (P_{p1}) of all Redshank prey, with ranges for each class across all P_{p1} conditions. For details of classes, see Fig 71

between 50 and 100 $J.s^{-1}$ handling. The smallest (class 4) worms, all sizes of Macoma, and intermediate sized Hydrobia (2.0 - 3.4 mm) and Corophium (2.0 - 6.5 mm) had profitabilities in the range 15-50 $J.s^{-1}$ handling. The lowest profitability items were small (< 2 mm) Hydrobia and Corophium, which had profitabilities between 0 and 15 $J.s^{-1}$ handling.

Differences in the pattern of seasonal, site and tidal variation between species meant classes often changed ranks between seasons, across sites and even throughout the tidal cycle. For example, the decrease in profitability of small Macoma over the tidal cycle meant that at tidal exposure they had greater profitability than both 3.4 mm Hydrobia and 5 mm Corophium, whilst on the flow tide they had lower profitabilities. Profitabilities of large worms (classes 3 and 4) never changed ranks with profitabilities of other species.

(b) Gross protein profitabilities (P_{pi})

Ranges of P_{pi} across seasons, site and tidal cycle for selected size classes of each prey type are shown in Fig. 72. As with P_{gi} the range of P_{pi} within each species was very large. Across prey types variation in P_{pi} was similar to P_{gi} . There was a relative increase in the importance of both worms and Corophium and a decrease in the importance of Hydrobia. Similar transpositions across seasons, sites and tidal cycle as were recorded in P_{gi} (above) were also recorded in P_{pi} .

(3.18 4) Comparison of predicted and observed diets

(a) Direct Observations

Ingestion rates, (N_i) - the number of prey of the i th type ingested per square metre of mudflat searched, by a sample of visually foraging Redshank (>10 individuals) within each plot, under given

environmental conditions (air temperature, windspeed and hours since tidal emersion) were calculated.

$$N_i = \frac{n_i}{(v_p/T)x} \quad (35)$$

where n_i = the number of the i th prey observed ingested
 v_p = the predator velocity, estimated from the empirical relationship between pacing rate and velocity (section 3.17).

T = the total observation time

x = the effective foraging path width (section 3.9).

Observed ingestion rates (N_i) of each prey type were entered as the dependent variable in linear regression analyses with the predicted ingestion rates under each hypothesis as the independent variables, in each season.

Observed ingestion rates of 'small items' from sites known to contain very low or no Hydrobia or Corophium (plots 3 and 4 at Culross - section 2.2) suggested that, in the field, it was not possible to distinguish between small items and small Macoma. These two classes were therefore combined for the analysis. Predicted and observed intakes of large Macoma were excluded from the analysis because observed and predicted intakes in all seasons was nil, and inclusion of these data effectively constrained the fitted regression to pass through the origin. Plots where less than 1 m^2 was searched by the observed individuals were also excluded.

Predicted ingestion rates were similar across all four models. There was a significant positive relationship between the predicted ingestion rates of all four models and observed ingestion rates in each

Table 29

Explained variability ($r^2 \times 100$) in the observed intake of prey by foraging Redshank, in each season, by the predictions of each model (maximization of GROSS energy intake, NET energy intake, gross PROTEIN intake and RANDOM selection).

| Model | Autumn | Early Winter | Late Winter | Spring | n ¹ |
|---------|--------|--------------|-------------|--------|----------------|
| Gross | 51.9 | 43.3 | 51.9 | 38.5 | 66 |
| Net | 38.2 | 15.8 | 52.8 | 56.9 | 72 |
| Protein | 52.4 | 77.9 | 60.5 | 46.1 | 72 |
| Random | 28.9 | 14.8 | 48.2 | 17.1 | 80 |

n¹ = number of predictions across all prey types and plots

Coefficients of regression equations relating observed intake of prey by foraging Redshank and the predictions of each model.

| Model | Autumn | Early Winter | Late Winter | Spring |
|---------|--------|--------------|-------------|--------|
| Gross | 0.468 | 0.215 | 0.516 | 0.215 |
| Net | 0.592 | 0.242 | 0.64 | 0.322 |
| Protein | 0.370 | 0.555 | 0.650 | 0.445 |
| Random | 0.212 | 0.103 | 0.077 | 0.091 |

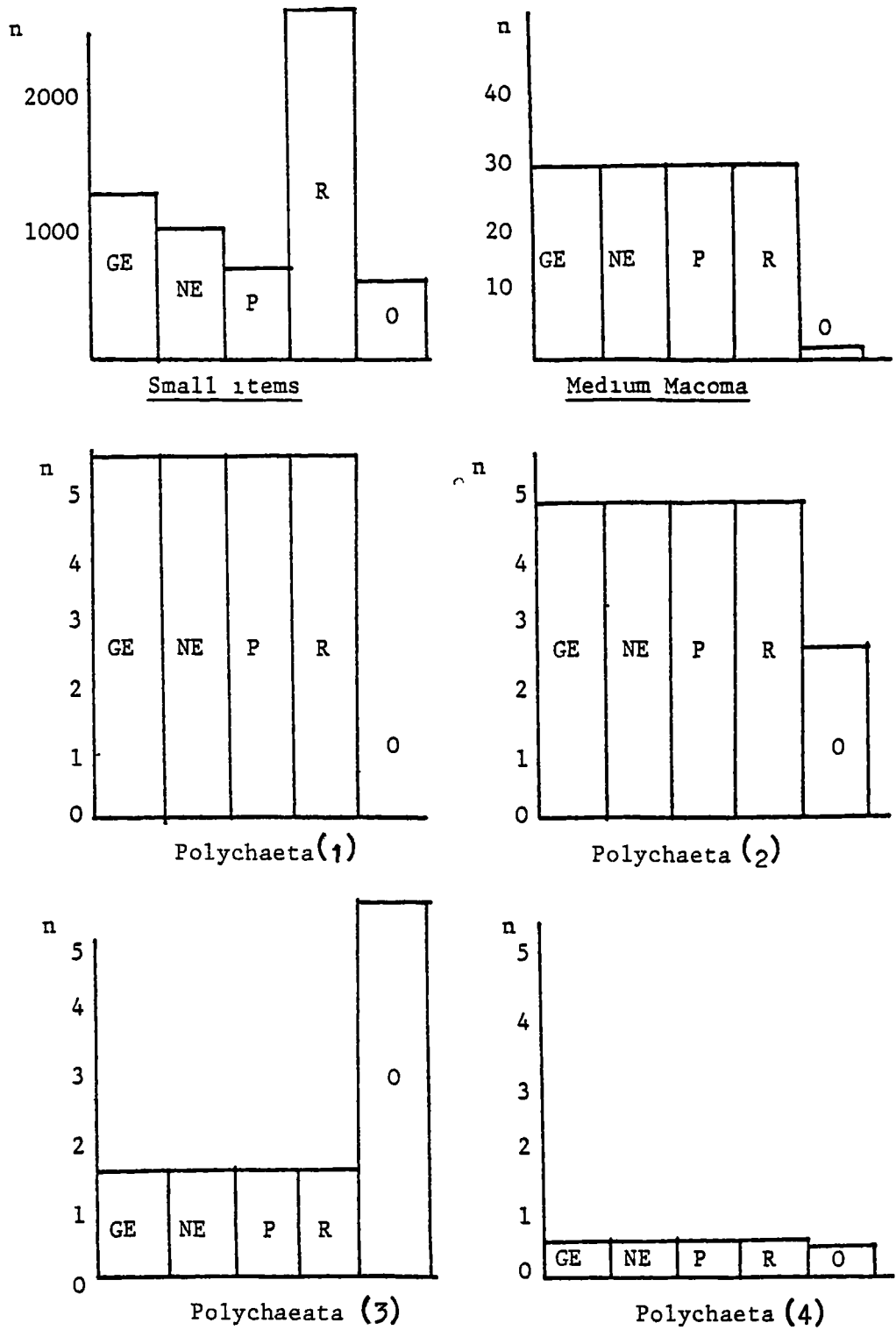

Fig 73

Predicted numbers of each prey type ingested, under each hypothesis, and numbers observed ingested, summed across all plots in Autumn

GE = Gross energy maximization prediction

NE = Net energy maximization prediction

P = Net energy maximization prediction

R = Random selection prediction

O = Observed selection

For details of Polychaeta size classes see Fig, 71

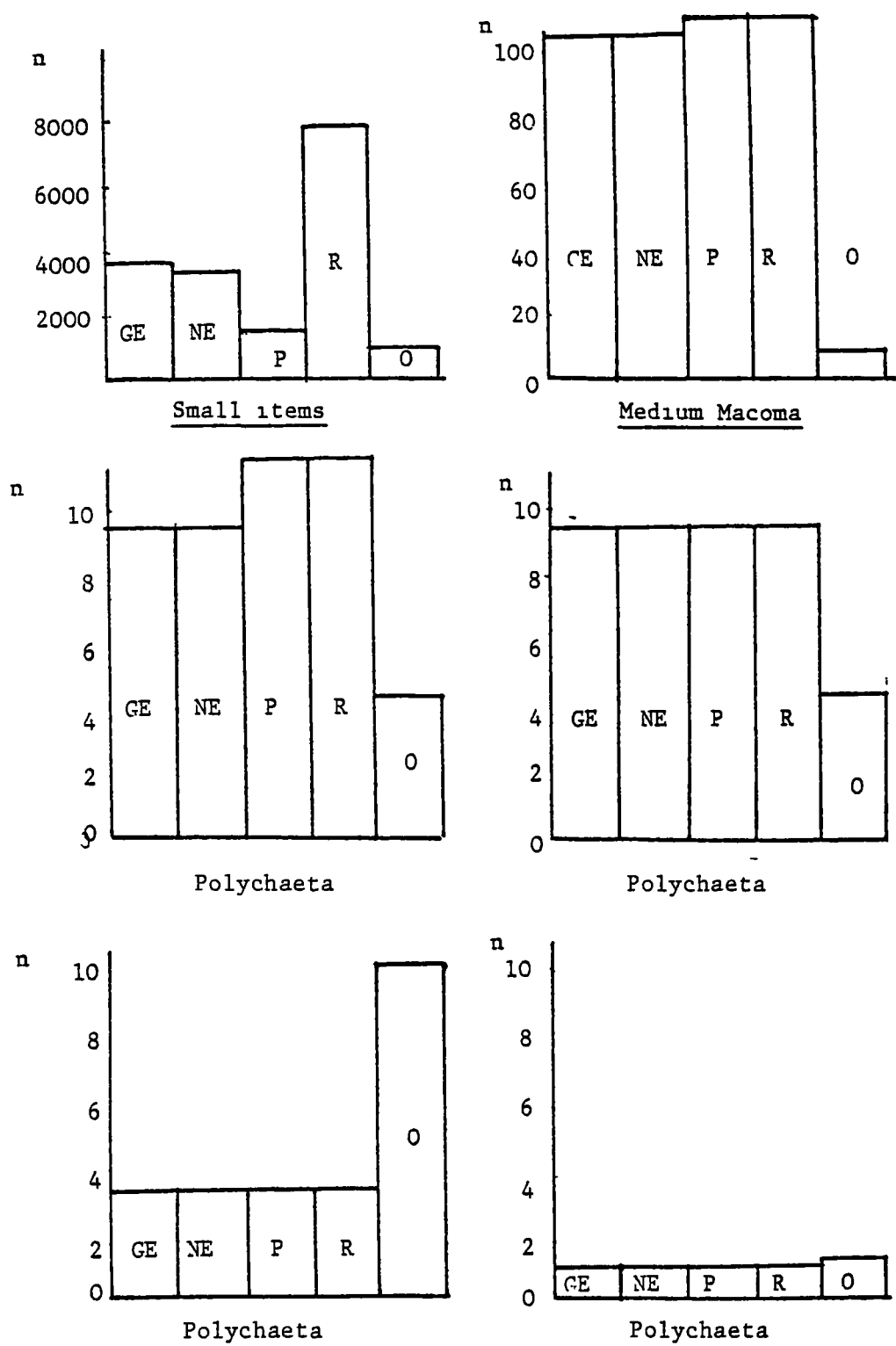

Fig 74

Predicted numbers of each prey type ingested, under each hypothesis, and numbers observed ingested, summed across all plots in Early Winter

GE = Gross energy maximization prediction

NE = Net energy maximization prediction

P = Protein maximization prediction

R = Random selection prediction

O = Observed selection

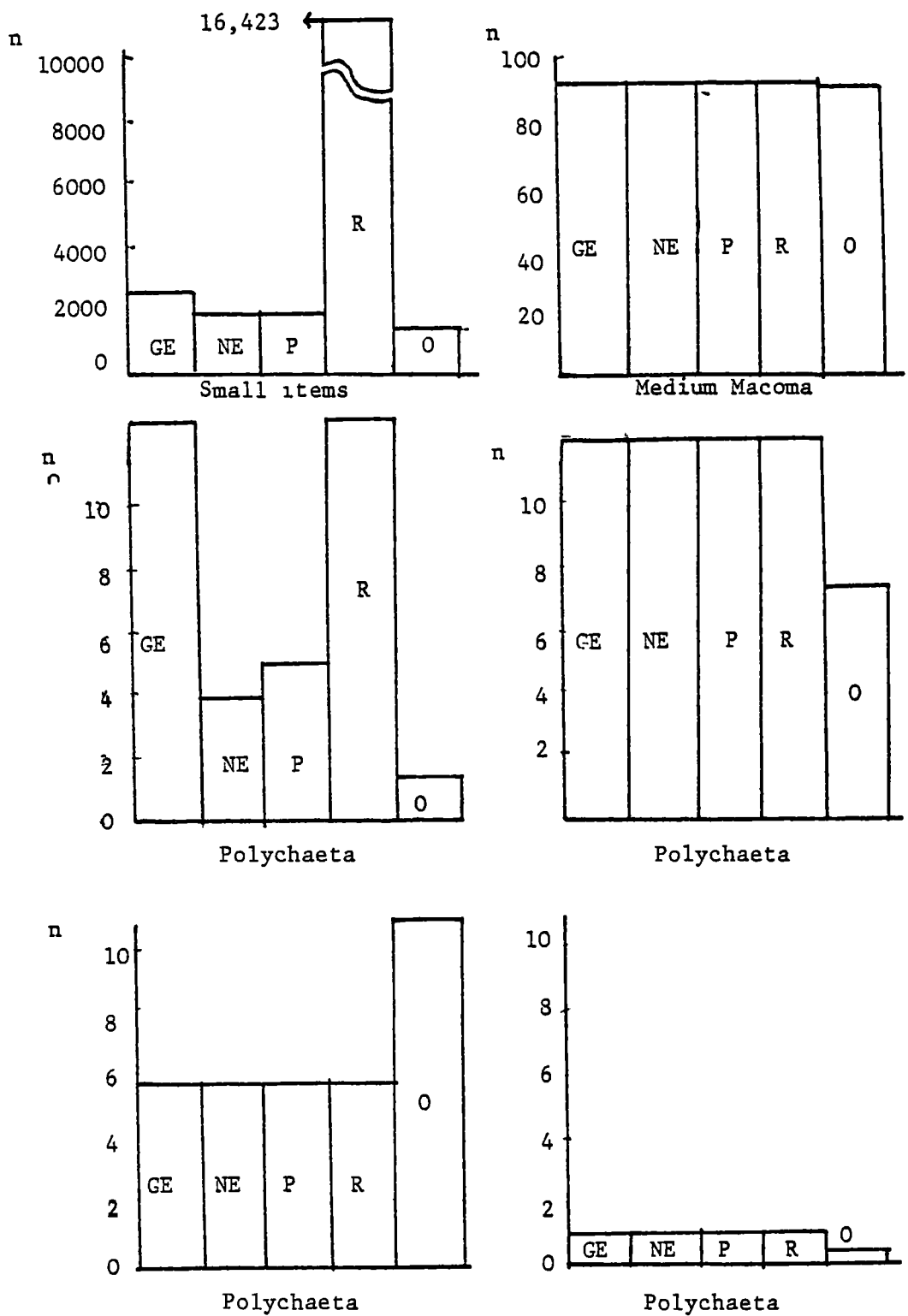

Fig 75

Predicted numbers of each prey type ingested, under each hypothesis, and numbers observed ingested, summed across all plots in Late Winter

- GE = Gross energy maximization prediction
- NE = Net energy maximization prediction
- P = Protein maximization prediction
- R = Random selection prediction
- O = Observed selection

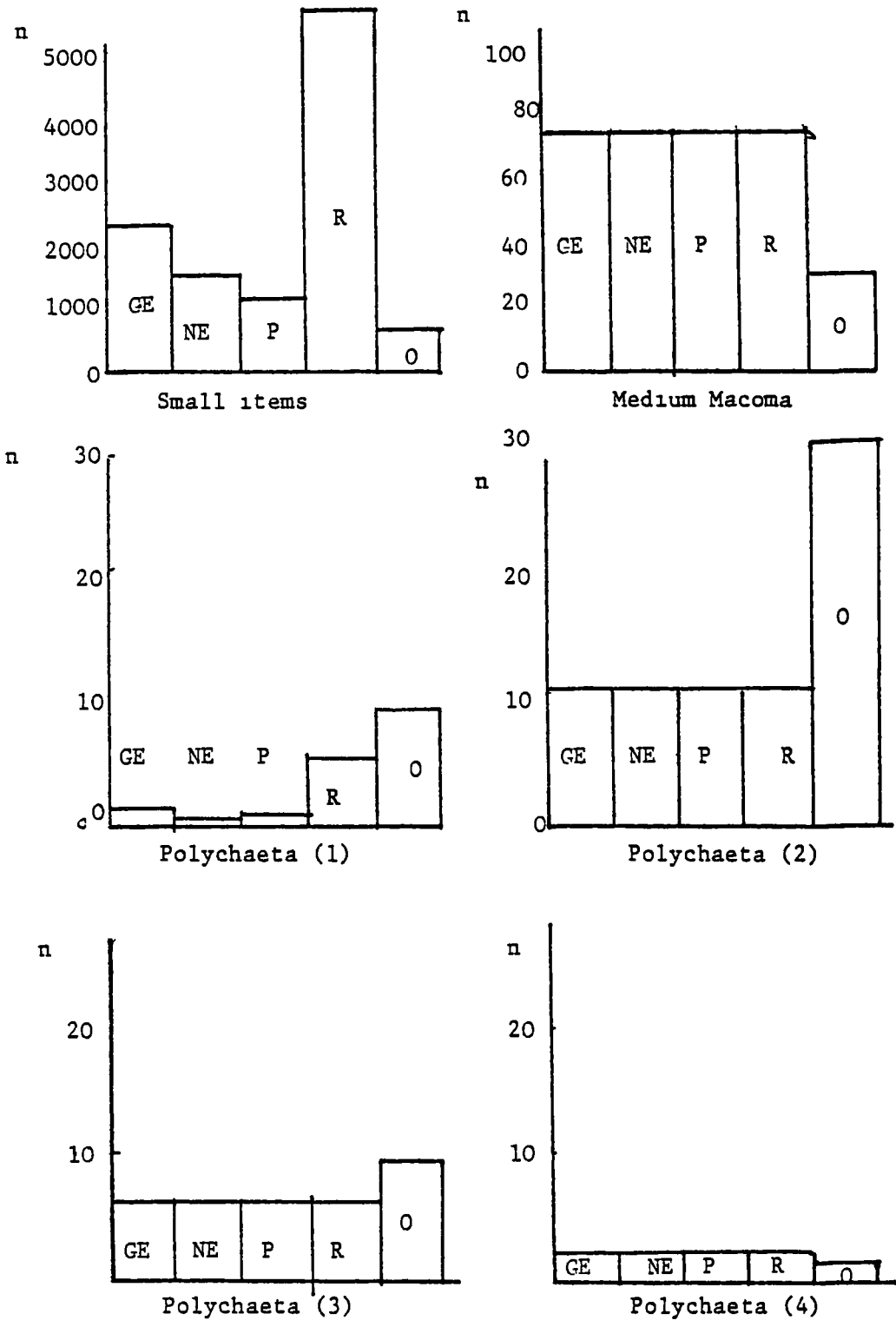

Fig 76

Predicted numbers of each prey type ingested, under each hypothesis, and numbers observed ingested, summed across all plots in Spring

- GE = Gross energy maximization prediction
- NE = Net energy maximization prediction
- P = Protein maximization prediction
- R = Random selection prediction
- O = Observed selection

Table 30

Predicted ingestion of all prey types from the maximization of gross energy, net energy and gross protein models, random selection, and the observed intakes, summed across all plots in AUTUMN.

| Model | Small items/ Small Macoma | Medium Macoma | 1 | 2 | Worms 3 | 4 |
|-----------------|------------------------------|------------------|-----|-----|------------|------|
| Gross Energy | 1275.2 | 29.9 | 5.6 | 4.8 | 1.6 | 0.46 |
| Net Energy | 1008.1 | 29.9 | 5.6 | 4.8 | 1.6 | 0.46 |
| Protein | 694.8 | 29.9 | 5.6 | 4.8 | 1.6 | 0.46 |
| Random | 2817.3 | 29.9 | 5.6 | 4.8 | 1.6 | 0.46 |
| Observed | 597.2 | 2.2 | 0 | 2.6 | 5.7 | 0.38 |

1 Classes = 1 3 - 19 mm
2 20 - 35 mm
3 36 - 58 mm
4 > 59 mm

Table 31

Predicted ingestion of all prey types from the maximization of gross energy (GROSS), net energy (NET), gross protein models, random selection and observed intakes, summed across all plots, EARLY WINTER.

| Model | Small items/ small Macoma | Medium Macoma | Polychaeta | | | |
|-----------------|------------------------------|------------------|------------|------|------|------|
| | | | 1 | 2 | 3 | 4 |
| Gross Energy | 3631.9 | 101.3 | 9.7 | 9.5 | 3.2 | 0.94 |
| Net Energy | 3244.5 | 101.3 | 9.7 | 9.5 | 3.2 | 0.94 |
| Protein | 1430.9 | 101.3 | 11.0 | 9.5 | 3.2 | 0.94 |
| Random | 7607.8 | 101.3 | 11.0 | 9.5 | 3.2 | 0.94 |
| Observed | 783.6 | 7.8 | 0.8 | 4.22 | 10.6 | 1.0 |

Table 32

Predicted ingestion of all prey types for the maximization of gross energy, net energy, and gross protein models, random selection and observed intakes summed across all plots in LATE WINTER

| Model | Small items/ small Macoma | Medium Macoma | 1 | Polychaeta 2 | 3 | 4 |
|-----------------|------------------------------|------------------|------|-----------------|------|-----|
| Gross Energy | 2451.6 | 95.4 | 13.4 | 11.9 | 5.7 | 0.9 |
| Net Energy | 1979.7 | 95.4 | 3.9 | 11.9 | 5.7 | 0.9 |
| Protein | 1928.4 | 95.4 | 4.7 | 11.9 | 5.7 | 0.9 |
| Random | 16423.7 | 95.4 | 13.5 | 11.9 | 5.6 | 0.9 |
| Observed | 1261.8 | 92.0 | 1.3 | 7.2 | 10.7 | 0.3 |

Table 33

Predicted ingestion of all prey types for the maximization of gross energy, net energy, and gross protein models, random selection and observed intakes, summed across all plots in SPRING

| Model | Small items/ small Macoma | Medium Macoma | Polychaeta | | | |
|-----------------|------------------------------|------------------|------------|------|-----|-----|
| | | | 1 | 2 | 3 | 4 |
| Gross Energy | 2231.8 | 75.9 | 0.9 | 10.1 | 5.7 | 1.9 |
| Net Energy | 1487.3 | 75.9 | 0.4 | 10.1 | 5.7 | 1.9 |
| Protein | 1082.6 | 75.9 | 0.5 | 10.1 | 5.7 | 1.9 |
| Random | 5262.3 | 75.9 | 4.9 | 10.1 | 5.7 | 1.9 |
| Observed | 479.7 | 28.5 | 8.04 | 29.7 | 9.2 | 1.2 |

season (Table 29).

Variability in observed diet choice was best explained by the maximization of gross protein intake model in Autumn, Early Winter and Late Winter. This model explained 52.4, 77.9 and 60.5% of the variability in ingestion rates between classes in Autumn, Early Winter and Late Winter respectively, whilst the maximization of gross energy model explained 51.9, 43.3 and 51.9%, the maximization of net energy model explained 38.2, 15.8 and 52.8%, and the random selection model explained 28.9, 14.8 and 48.2% of the variability in observed ingestion rates in the same seasons. On average, protein maximization explained between 15 and 30% more of the variability in diet choice than any of the other models in these seasons.

In Spring the maximization of net energy gain model explained the most variability in ingestion rates (56.9%) compared with 38.5, 46.1 and 17.1% for the maximization of gross energy and protein intake, and random selection respectively.

In all the fitted regressions except those with random prey selection predictions as the independent variable the constants of the regression equations were not significantly different from zero. However, the regression coefficients of all the fitted regression equations were all significantly less than one (the expected). The closest regression coefficients to one were provided by the models which also explained the most variability in ingestion rates in each season.

Predicted and observed ingestion rates of each class summed across all plots in each season are shown in Tables 30 to 33 and Figs. 73 to 76. Consistently across all four seasons Redshank selected fewer 'small items plus small Macoma' than predicted by any model. In addition, medium sized Macoma were also underselected in all seasons except Late

Winter. In Autumn and Spring, Redshank managed to obtain more worms than were predicted available.

The percentage of encountered small items which were ingested was non-linearly, and inversely, related to the availability of high profitability worms - classes 2, 3 and 4 (section 3.18.2(d)) Fig. 78

(b) Collections around search paths

Size frequency distributions of Hydrobia collected adjacent (< 5 cm from) to foraging Redshank paths and greater than 15 cm from the paths on a single tide are shown in Fig. 77. Size selection was assessed by calculating a selection index (SI) for each class n.

$$SI_n = \frac{\text{percent frequency of class n away from path}}{\text{percent frequency of class n adjacent to path}} \quad (36)$$

Selection indices greater than unity indicate selection of that class, whilst values less than one indicate rejection. Values of SI_n for each class across two tides at 7°C, within two hours of tidal emersion, in Spring, with the predicted inclusion points, from each model are shown in Fig. 79. Under these conditions Redshank selected Hydrobia > 2.8 mm in length, compared with predicted inclusion points of 2.6 mm. from the maximization of gross and net energy models and 3.2 mm. from the maximization of gross protein intake. Intakes were more consistent therefore with energy maximization hypotheses under these conditions. Unfortunately, collections in Winter were impossible because the low surface availability in these seasons (section 2.8 1) meant it was not possible to find a sufficiently large sample of Hydrobia on which comparisons could be made.

(c) Pellet contents

Pellets ejected at roost sites used only by Redshank, at Skinflats,

Percentage of encountered
small items ingested

(%)

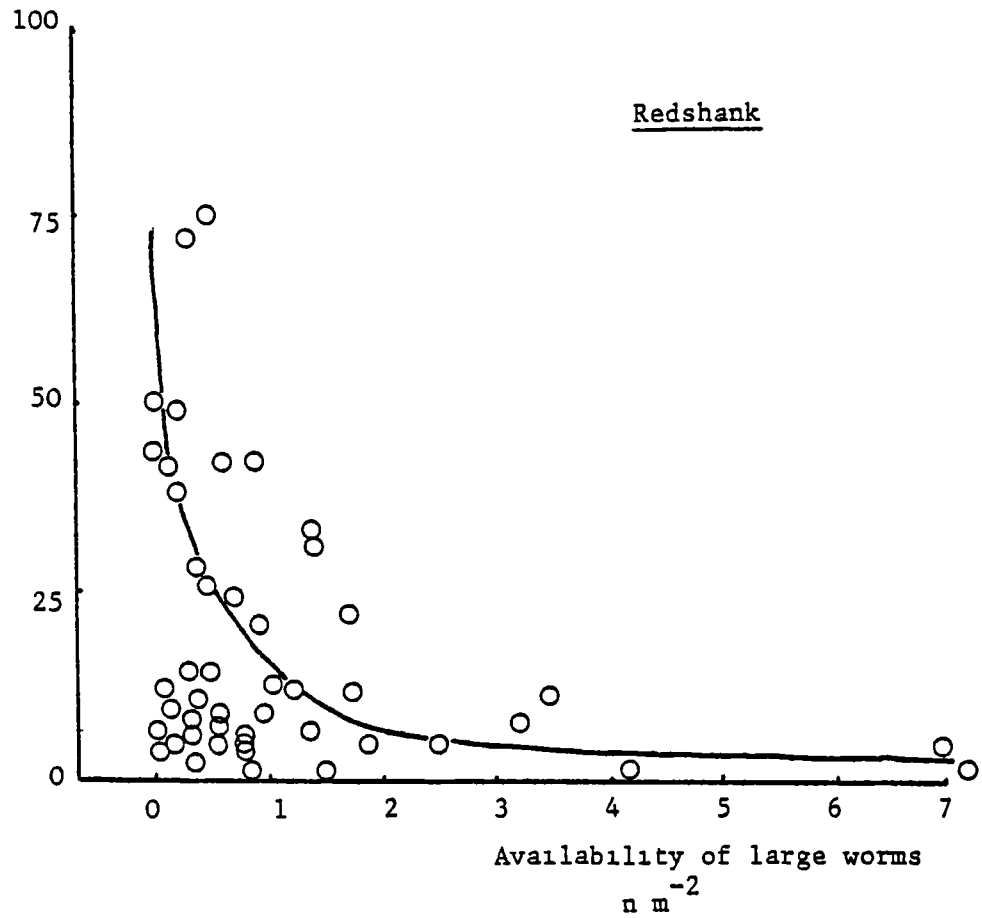

Fig 77

Percentage of small items encountered which are ingested by Redshank against the availability of large worms (highest three profitability classes) ($n m^{-2}$) Curve equals fitted regression equation

$$\log_e y = 2.48 - 0.69x$$

$$r^2 = 0.34$$

$$F = 16.4$$

$$n = 46$$

$$p < 0.05$$

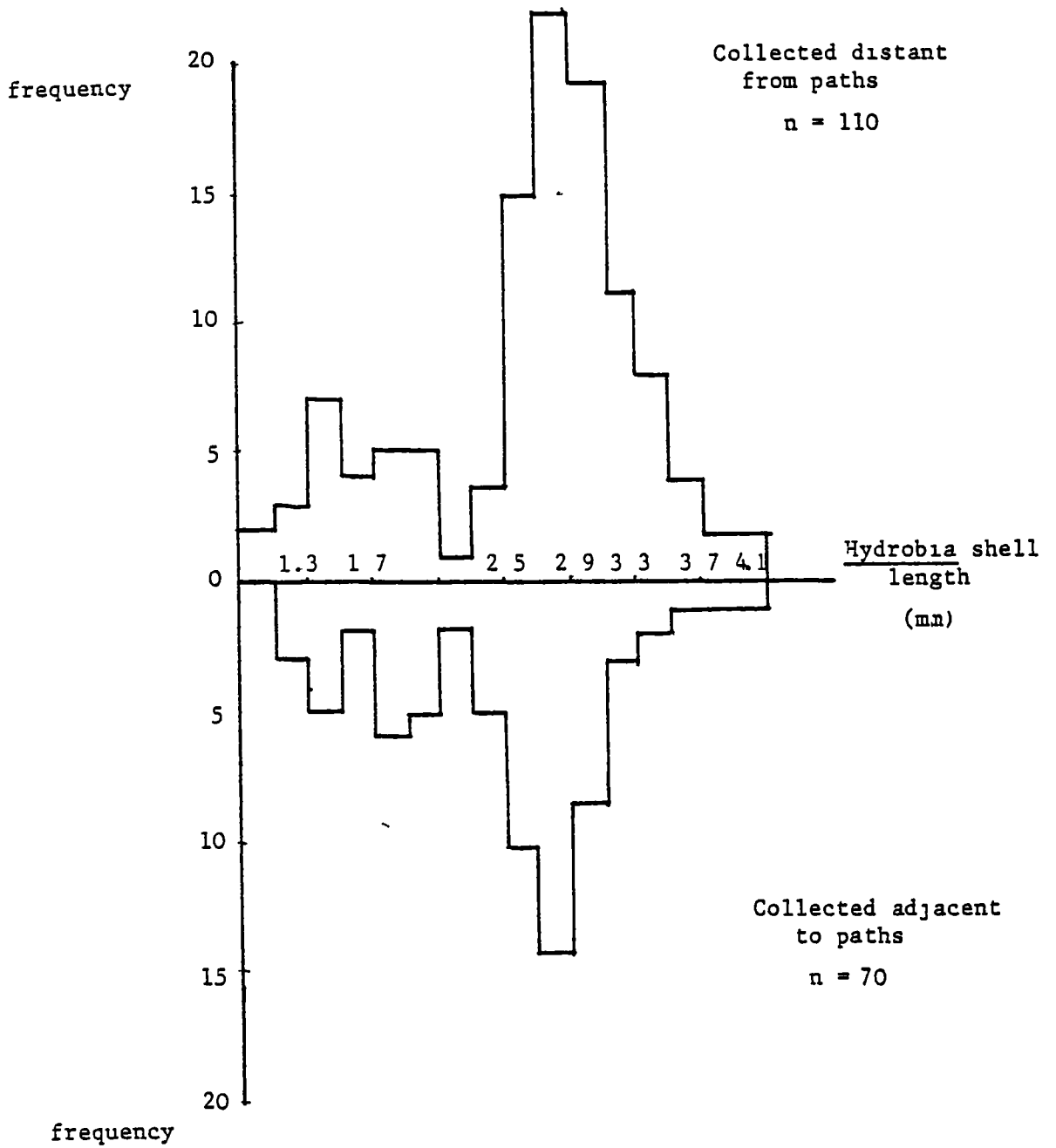

Fig 78 Size/frequency distributions of Hydrobia ulvae collected from the mud surface distant from (>15 cm from) and adjacent to (<5 cm from) fresh Redshank foraging paths on a single tide at 7°C (Spring 1982)

Selection
Index

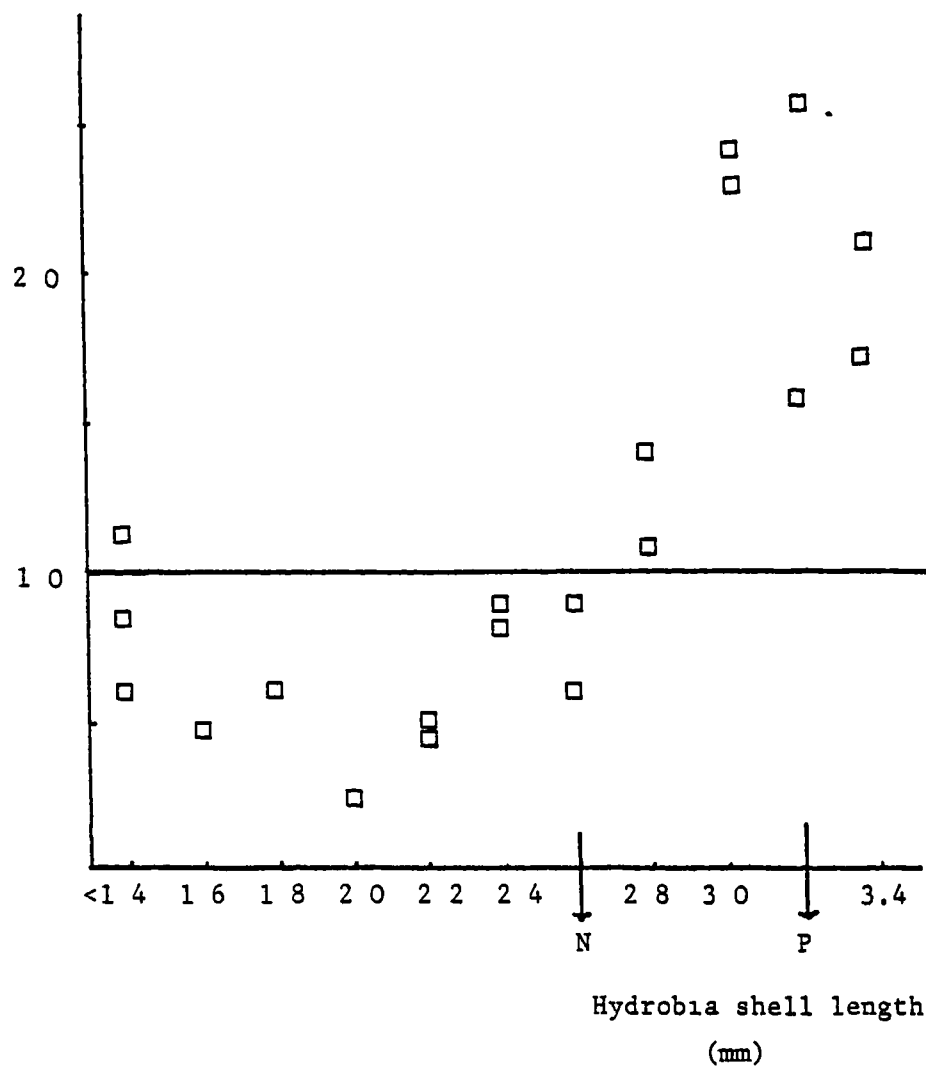

Fig 79

Selection indices calculated from percentage frequency/size histograms of Hydrobia ulvae collected near to and distant from fresh Redshank foraging paths against Hydrobia shell length. An index >1.0 indicates selection and an index <1.0 rejection. Each point represents data from an independent tide at $7-8^{\circ}\text{C}$ in Spring. The predicted points at which Redshank should include all prey of greater size and reject all smaller prey, under the net energy maximization (N) and protein maximization (P) hypothesis are shown.

were collected on four tides in Autumn, two tides in Early Winter, and four tides in Spring. No pellets were found in Late Winter.

Evidence of all four of the major prey were found in the pellets. Fragments of Macoma and Hydrobia shells were too disintegrated to allow a prediction of the ingested size frequency distributions, and whole Hydrobia were encountered only infrequently. An analysis of Nereis jaw lengths was not performed because it was not possible to distinguish between the alternate hypotheses using Nereis selection because all four models predict inclusion. Fragments of Corophium were common in pellets. The most common remains were the protopodite of the second antennae and the basipodite of the elongate fourth peripod. The protopodite was more reliably identified and all predictions of ingested size distributions were made using this fragment alone.

(i) Relationship between the length of the protopodite of and total length of the second antennae

There was a significant positive linear relationship between the length of the protopodite of and the total length of the second antennae (Fig. 80) across both size and season. On average, the protopodite was 27.1% of the total second antennal length. The ratio of its length to the total length did not vary across sizes or seasons.

(ii) Relationship between body length and length of the second antennae

Large Corophium, with long bodies, also had long second antennae (Fig. 81) The relationship between length of the second antennae and body length varied across seasons, because there was a significant positive relationship between the length of the second antennae, in an animal of given body length, and the mean daily maximum air temperature (Phizacklea, pers. comm.) for the month in which the sample was collected (Table 34). Corophium had longer second antennae in the summer - when it

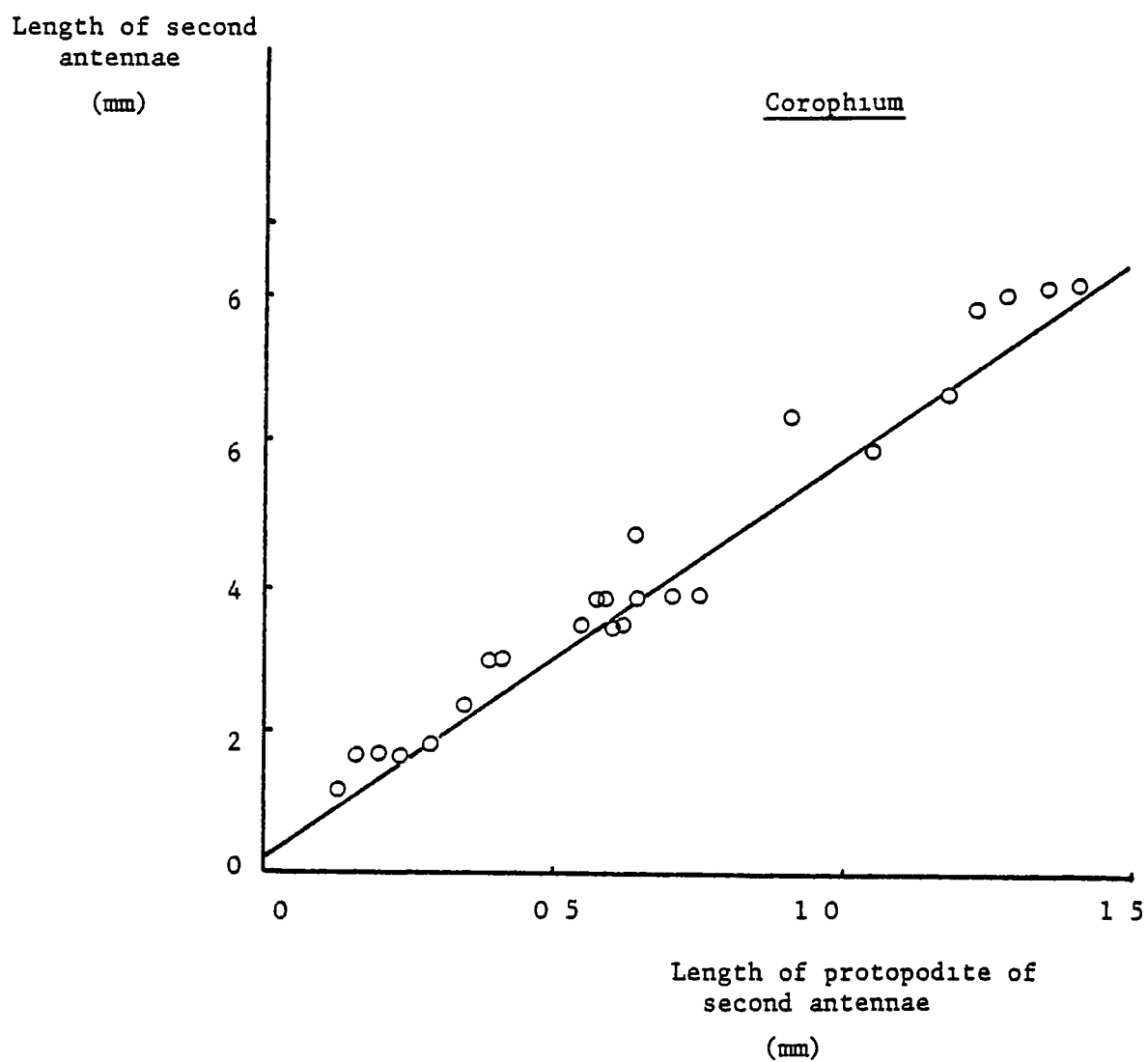

Fig 80 Length of the second antennae of Corophium volutator against length of the protopodite of the second antennae — Curve equals fitted regression equation

$$y = 0.258 + 5.38x$$

$$r^2 = 96.3\%$$

$$F = 546.97$$

$$n = 22$$

$$p < 0.001$$

Table 34

Results of a multiple regression analysis with length of the second antennae of Corophium volutator (mm) entered as the dependent variable against body length (mm) and mean daily maximum temperature of the month in which the sample was collected as independent variables.

| Variable | Coefficient | Coefficient | t |
|------------------|-------------|-------------|------|
| Body length | 0 66 | 0.022 | 30.6 |
| T ^o C | 0 05 | 0 006 | 8.12 |
| Constant | -0 6924 | - 0.10 | 6.6 |

Analysis of variance

n = 288

| Source | SS | MS | F | P |
|------------------|--------|--------|-------|--------|
| Regression | 198 37 | 99.19 | 495 2 | < .001 |
| Body length | 185 16 | 185.16 | 924 4 | < .001 |
| T ^o C | 13 21 | 13 21 | 69 9 | < .001 |
| Residual | 57 08 | 0.2 | | |

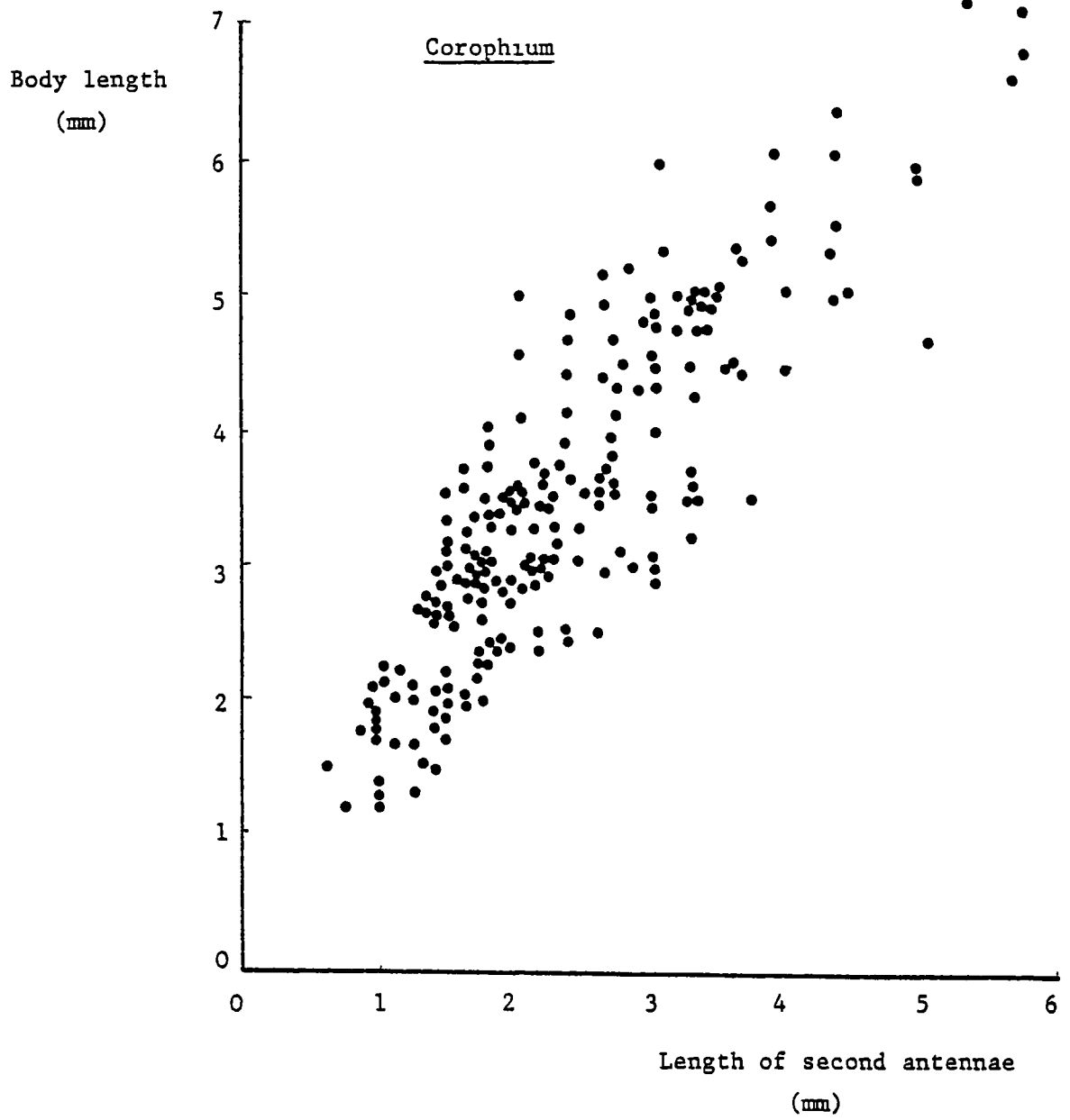

Fig 81 Body length of Corophium volutator against length of the second antennae Data pooled across sites and seasons (n = 288)

was warmer for an animal 40 mm body length, the predicted second antennae length in July was 288 mm. compared with 223 mm. in January

Although body lengths of Corophium selected for the analysis were not related to the mean daily air temperature of the month in which the sample was collected ($r = -0.04$), this temperature entered a stepwise multiple regression analysis, as a highly significant predictor, when body length was the dependent variable and length of the second antennae the first independent variable, because of the relationship between second antennal length and temperature (Table 34).

(iii) Observed and predicted diet choice

Ingested body lengths were predicted from second antennae protopodite lengths using the empirically derived relationships between protopodite length and second antennae length, and length of the second antennae with body length (above). Predicted body lengths were then allocated to 1 mm. size classes. The high predictability of both relationships ($r^2 = 96.6$ and 76.7%) meant the probability of allocating a predicted length to the correct class was greater than 70%

Because the exact feeding location of roosting birds was unknown, predictions of diet choice were made using an average density estimate for each prey class across all five observations plots at Skinflats (section 2.2). Observations of the exploitation pattern of Redshank suggested that all the Redshank roosting at sites used for pellet collections had been feeding immediately previously in at least one of the observation plots

Predicted inclusion points for Corophium were the same across all tides in each season. The predicted body lengths ingested across all tides in each season were pooled. Ingested numbers of each size class and encountered prey in each season are shown in Fig 82 a-c

Fig 82 Frequencies of each size of Corophium available to foraging Redshank (environment) and frequencies selected by foraging Redshank (selected) Sizes selected inferred from measurements of fragments ejected in pellets adjacent to the feeding sites

(A) Autumn

(B) Early Winter

(C) Spring

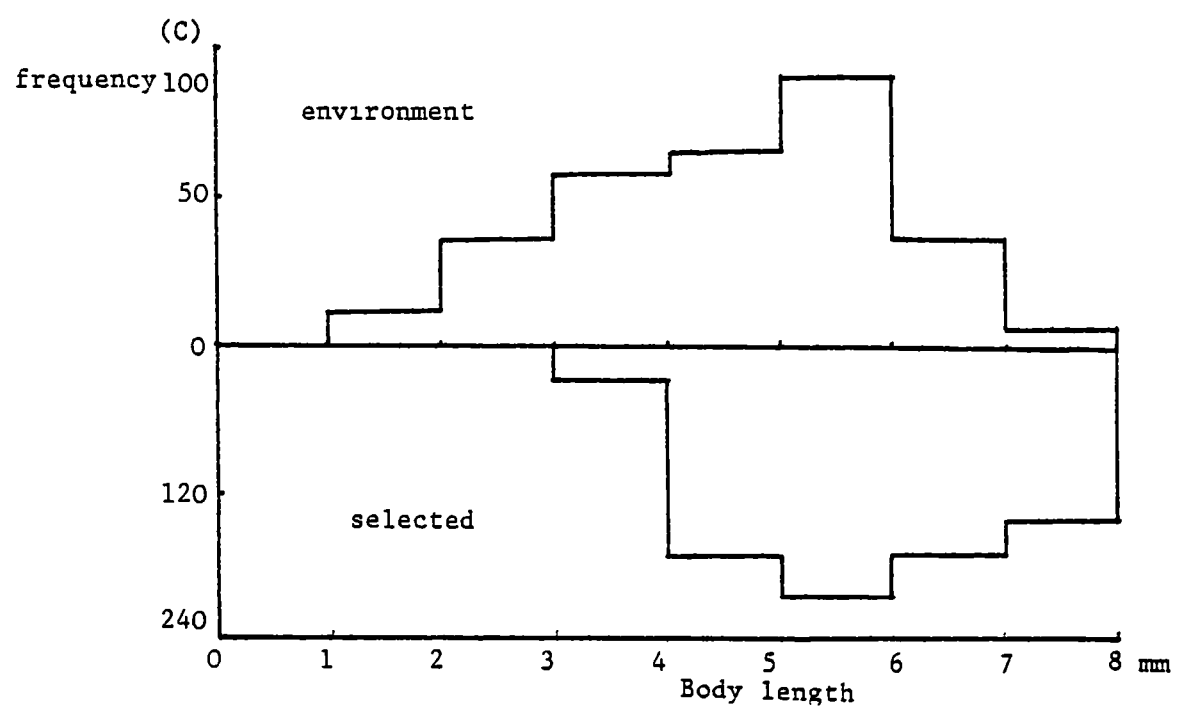
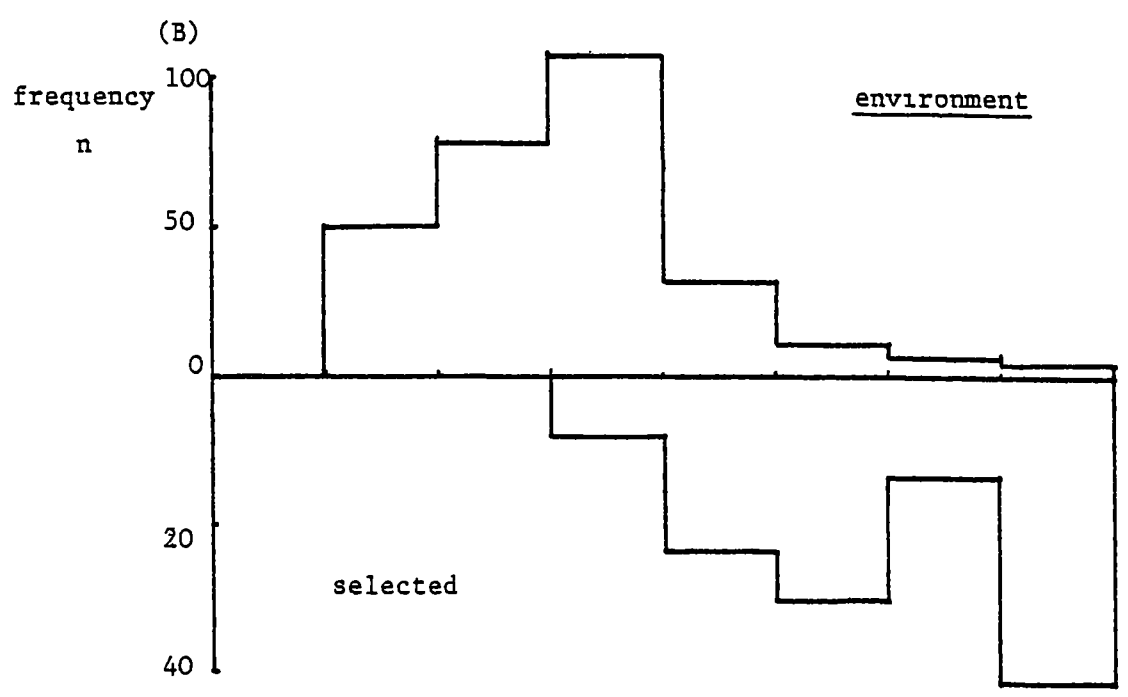
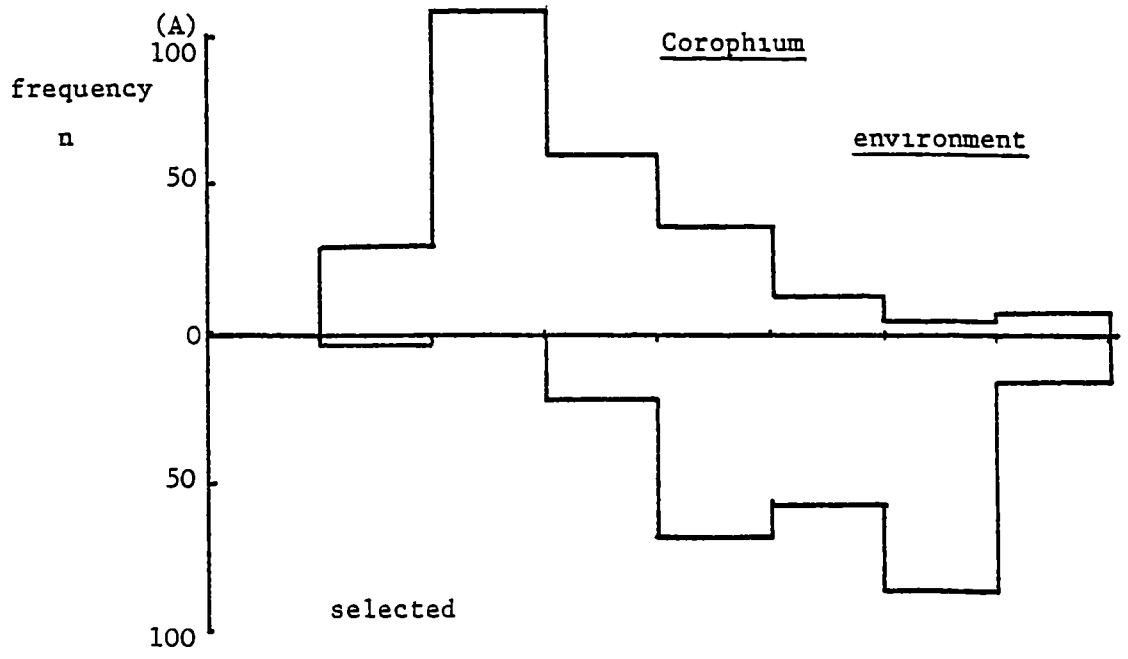

Size selection was assessed by calculating a selection index (SI) for each class n

$$SI_n = \frac{\text{percent frequency of class in pellets}}{\text{percent frequency of class in mud}}$$

Selection indices for each class with the predicted inclusion points from models derived from each hypothesis (section 3.18) are shown in Fig. 83. In Autumn and Early Winter, Redshank selected Corophium greater than 4 mm long. In Autumn this selection was the same as that predicted by the maximization of gross protein model, but included more items than predicted by the maximization of gross and net energy intake. In Early Winter this selection matched both the gross protein and gross energy maximization models but included more than the maximization of net energy gain prediction.

In Spring, the birds were more selective and ingested preferentially only those Corophium > 6 mm in body length. This inclusion point was greater than predicted by all three models but was much closer to the point predicted by the maximization of gross and net energy gain models than that predicted by the maximization of gross protein gain.

(3.19) Diet Choice - Oystercatcher

(3.19.1) Hypothesis and alternate hypotheses

(a) Gross and net energy gain and gross protein gain

Diets were predicted as in Redshank.

Since direct estimates of energy expenditure whilst handling prey were not available, the energy costs of prey handling were estimated from the relative costs of prey handling, as multiples of the observed resting metabolism, in Redshank. The relative costs of ingesting and recognizing

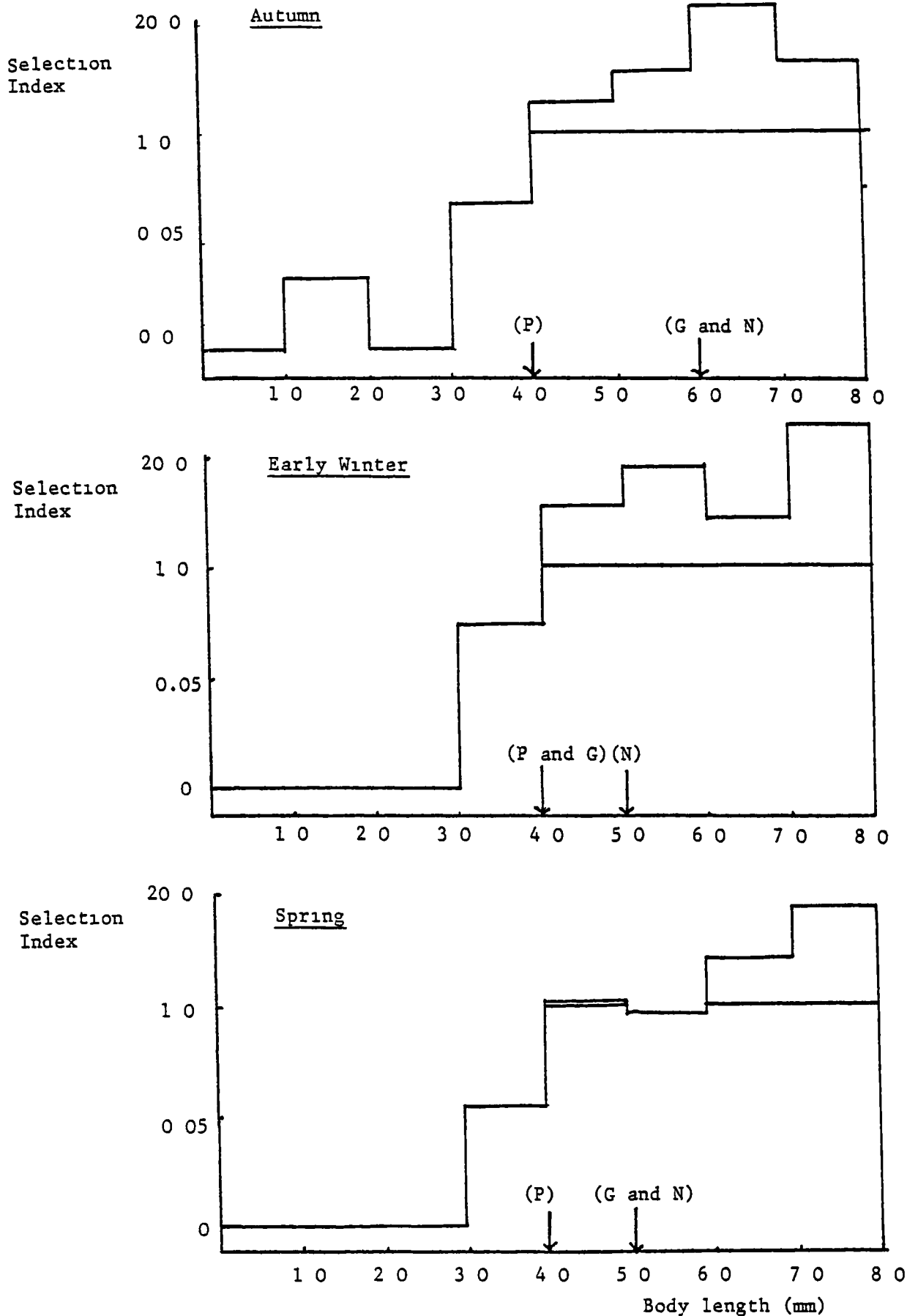

Fig 83

Selection indices calculated from percentage frequency/size histograms of Corophium volutator, collected from the environment and predicted from fragments removed from Redshank pellets in Autumn, Early Winter and Spring. An index >1.0 indicates selection, an index <1.0 rejection, and an index of 0 indicates total rejection. The predicted points at which Redshank should include all prey of greater size and reject all smaller prey, under the net (N) and gross (G) energy maximization and protein (P) maximization hypotheses are also shown.

pecks, were assumed to equal that of pecking, and the relative cost of manipulation was assumed to equal that of probing.

(b) Random selection

Mussels cover a high proportion of the mud surface (section 3.2), hence an Oystercatcher probing at random has a high probability of contacting a mussel. Oystercatchers probing at random will select the largest mussels because random probes are more likely to strike large mussels, which present a greater cross-sectional area, but also because small mussels are only found in the centre of mussel clumps and are consequently concealed by larger mussel. Predictions of size selection assuming random probing were made by multiplying the estimated density (section 3.2) by the relative probability of selection (= relative size multiplied by relative exposure).

(i) Relative size

Probes are made by Oystercatchers at an angle between 40 and 60° (range of 110 estimates across three captive individuals). The area subtended at an angle of 45° was calculated as the mean of the areas subtended vertically and horizontally by mussels with the dorsal surface uppermost. Areas were estimated by outlining the shells of mussels between 1.0 and 7.8 cm in length onto graph paper.

There was a significant positive curvilinear relationship between the estimated subtended area at 45° and mussel length ($r^2 = 99.5$, $n = 50$, Fig. 84). Significant independent effects of shell height and width explained most of the residual variability. The largest (7.5 cm) mussels subtended an area approximately 950x greater than that of the smallest class (0.5 cm).

(ii) Relative exposure

Relative exposure was estimated as the area of a given mussel covered

Area subtended
at 45°

mm² (k)

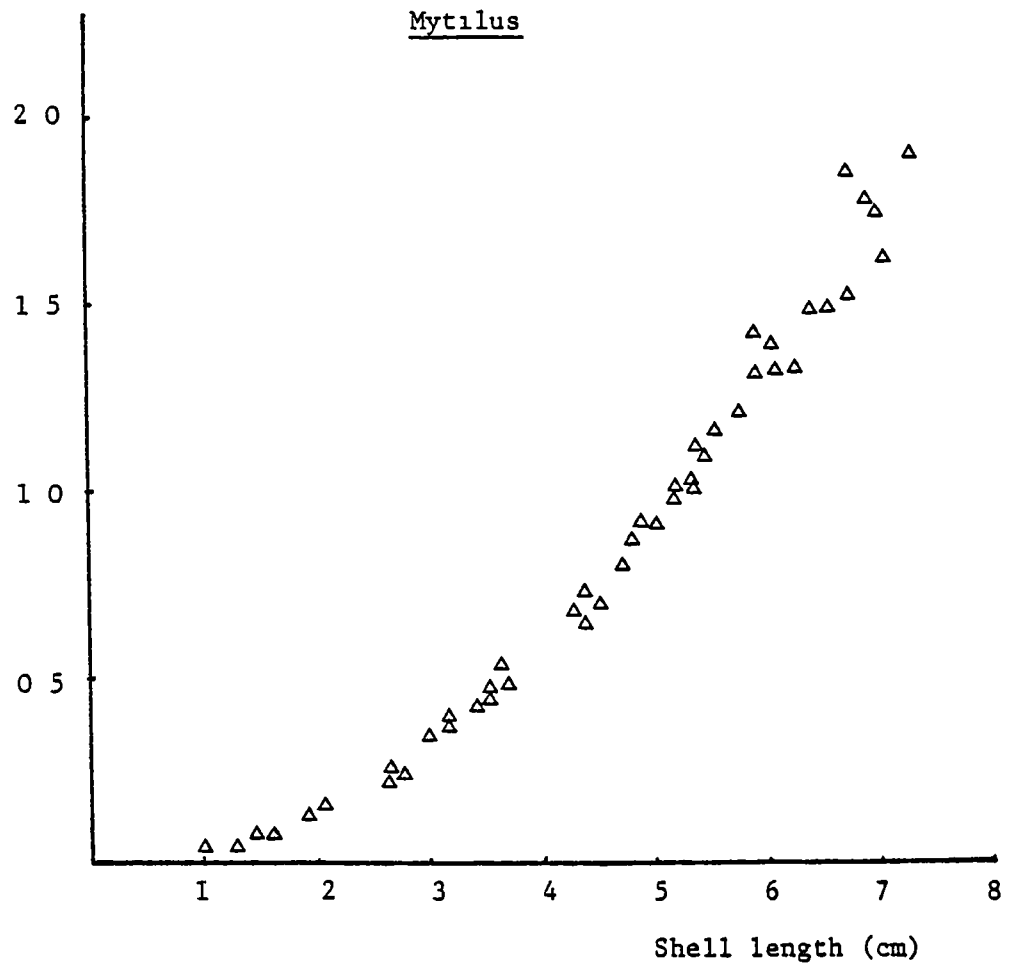

Fig 84

Area of mussels, subtended at an angle of 45° (mean of horizontal and vertical subtended areas) against shell length (cm) The curve equals the fitted regression equation

$$\log_e y = 3.52 + 2.0 \log_e x \quad r^2 = 99.5$$

$$F = 10,491.6$$

$$n = 50$$

$$p < 0.001$$

Percentage of mussel
exposed

Mytilus

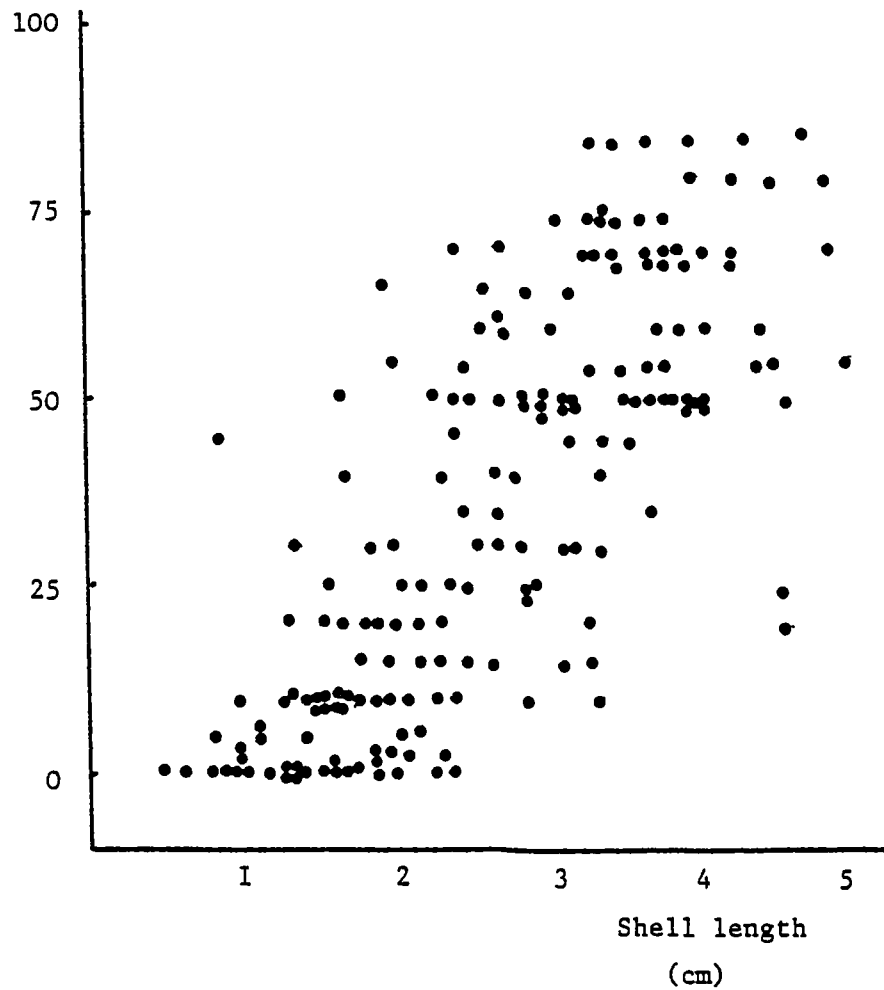

Fig 85

Percentage of mussel surface exposed against mussel length
Exposure was estimated by spray painting mussel clumps in situ
in the field and estimating the percentage paint coverage of
detached mussels later (n = 185)

with paint when removed from a clump of spray painted mussels (section 3.8.3). There was a significant positive, curvilinear, relationship between the estimated percentage of the surface exposed (painted) and mussel length, and a significant linear relationship with the estimated surface area (= twice the predicted horizontal area - above) (Fig. 85). The percentage exposed area of the largest (7.5 cm) mussels was 7x greater than the smallest mussels (0.5 cm).

In combination, the effects of greater area and greater exposure meant an Oystercatcher probing at random would be over 7000x more likely to encounter a mussel of the largest class (7.5 cm) than one of the smallest class (0.5 cm), if they occurred at equal densities.

(3.19.2) Spatial and temporal variation in profitability and variation resulting from differences in handling techniques

(a) Gross energy profitability (P_{gi})

In all seasons, across all plots, for both prizing and hammering individuals, there was a positive, curvilinear, relationship between P_{gi} and mussel length (e.g. Fig. 86). On average across all conditions the profitability of the largest mussels (7.75 cm) was between 5 and 10,000x greater than the profitability of the smallest mussels (0.25 cm).

Across all seasons, plots and sizes mussels opened by the hammering technique had greater profitability than those opened by prizing. The difference between hammering P_{gi} and prizing P_{gi} increased with an increase in mussel length, hence the largest (7.75 cm) mussels hammering P_{gi} averaged 1.8x the prizing P_{gi} whilst in the smallest mussels (0.25 cm) the difference averaged 1.42x.

Profitabilities were lowest at the centre of each mussel bed, opposite the pier end (section 2.2), and increased laterally along both beds to east and west. On average, the greatest profitabilities (plot 5)

in each season exceeded the lowest (in the same class at plot 2) by approximately 1.7x in prizers and 1.5x in hammerers. Seasonal variability in profitability was relatively unimportant. Because spatial and temporal trends in profitabilities of different size classes were similar across all size classes, size classes always had the same rank.

(b) Net energy profitability (P_i)

In all seasons across all plots, in both hammering and prizing Oystercatchers, there was a positive, curvilinear, relationship between P_i and mussel length. The relative effects of including costs on profitability varied with mussel length. Costs were more important in smaller mussels (fig. 86). In large mussels (> 5.75 cm) costs were relatively small and across all conditions P_i exceeded 80% of P_{gi} in prizers and 90% of P_{gi} in hammerers. In small (< 1.25 cm) mussels costs exceeded gains and therefore P_i was negative.

(3.19.3) Variation in the probability of finding opened mussel shells on the mussel bed in relation to shell size

The probability of finding an opened mussel, in a test to establish bias in shell collections, increased non-linearly with increases in mussel length (Fig 87). Large (6 cm) mussels were approximately 5x more likely to be found than small (2 cm) mussels. The probability of finding an opened mussel was linearly related to the exposed area of the mussel (= twice the horizontal subtended area - section 3.19).

(3.19.4) Comparison of predicted and observed diets from mussel shell collections

(a) Prizing

Predicted diet inclusion points from the maximization of gross and net energy gain models were the same across all plots and seasons. The size distribution of mussels available (section 3.8.3), predicted intakes

Profitability

$J s^{-1}$

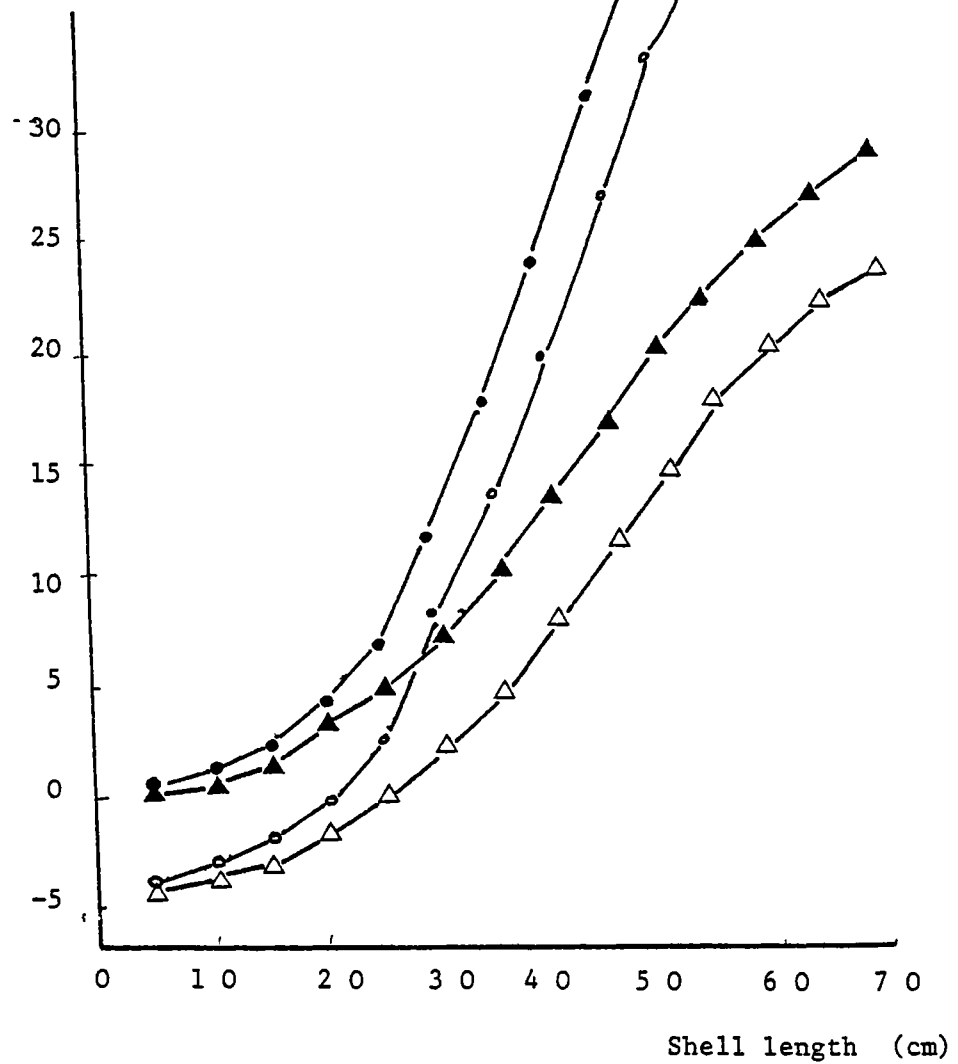

Fig 86 Gross (P_{g1}) and Net (P_{n1}) profitability of mussels to Oystercatchers, against shell length for a typical plot (plot 7) in Late Winter

- ▲ Gross Profitability - Prizers
- △ Net Profitability - Prizers
- Gross Profitability - Hammerers
- Net Profitability - Hammerers

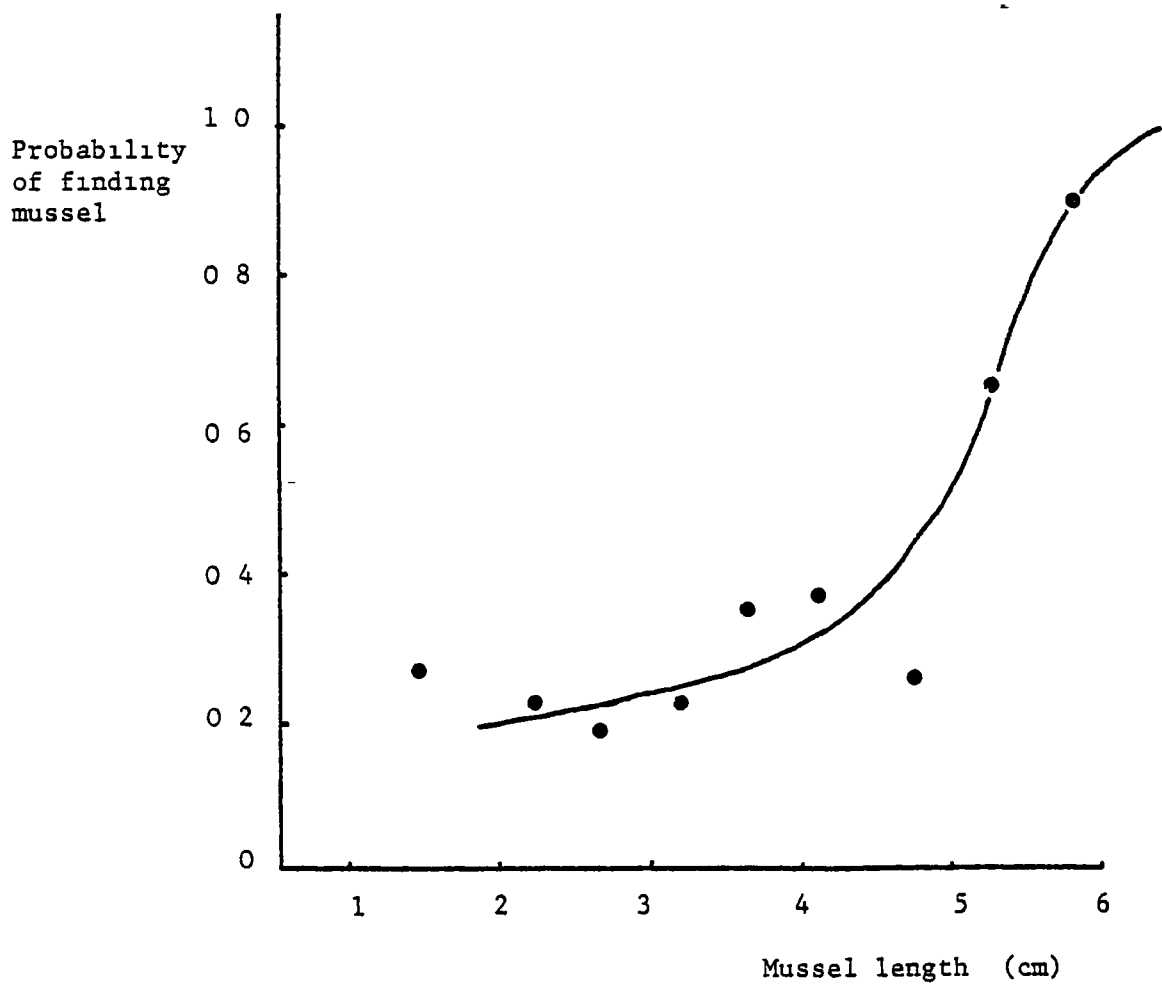

Fig 87

A test to establish bias in shell collections probability of finding a mussel shell opened by an Oystercatcher on the mussel bed against shell length (Curve fitted by eye)

Fig 88 Numbers of mussels of each size class encountered,
and predicted to be ingested by the random encounter model,
Fig 89 the energy maximization model and observed ingested
by 'prizing Oystercatchers at two example plots

Fig 88 plot two, upper mussel bed, Late Winter

Fig 89 plot five, lower mussel bed, Early Winter

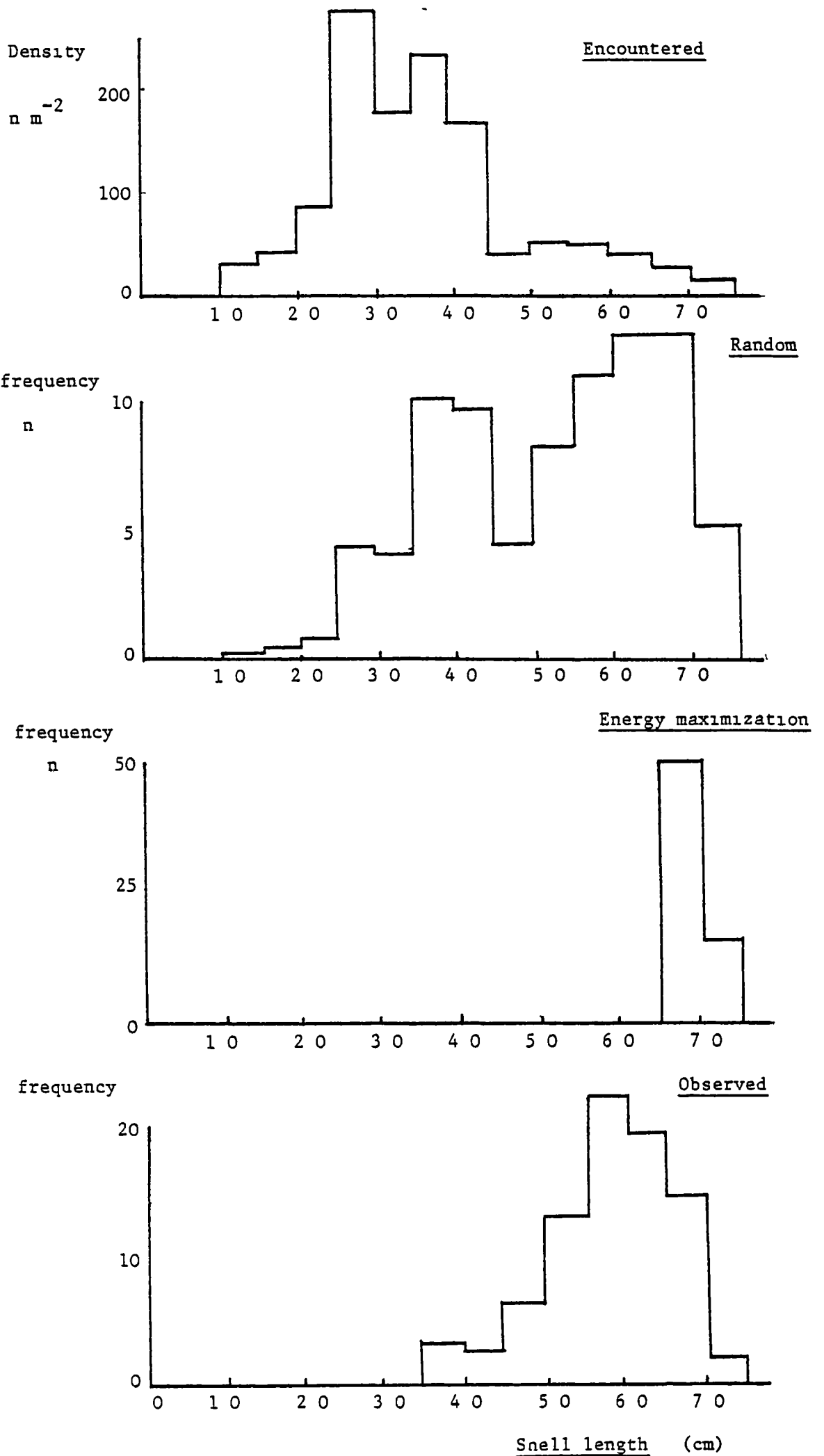
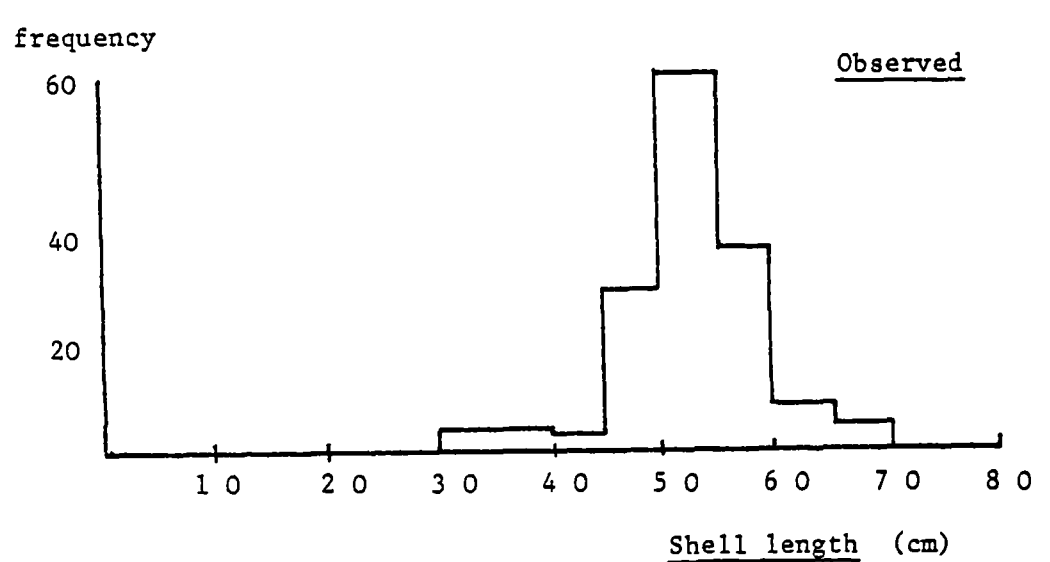
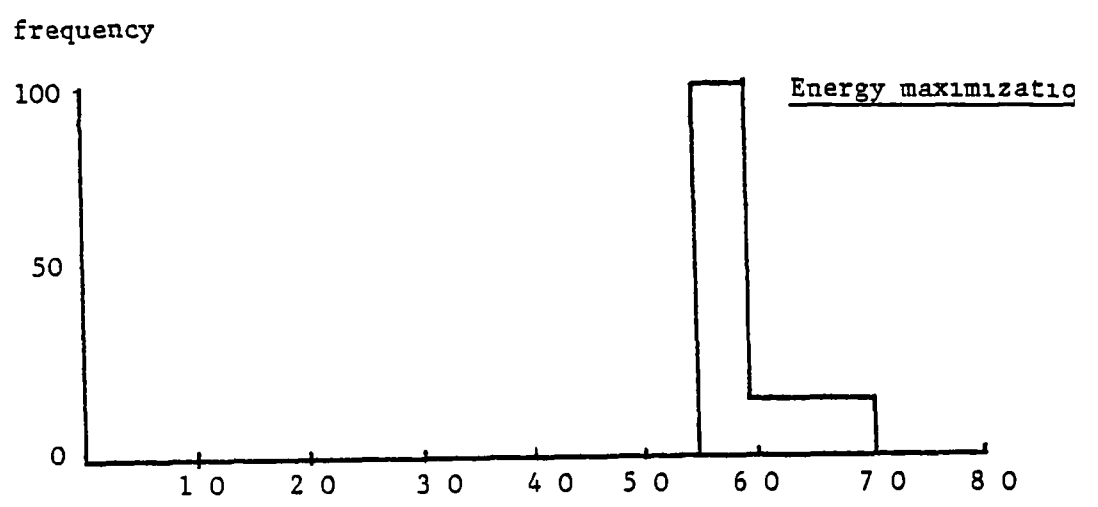
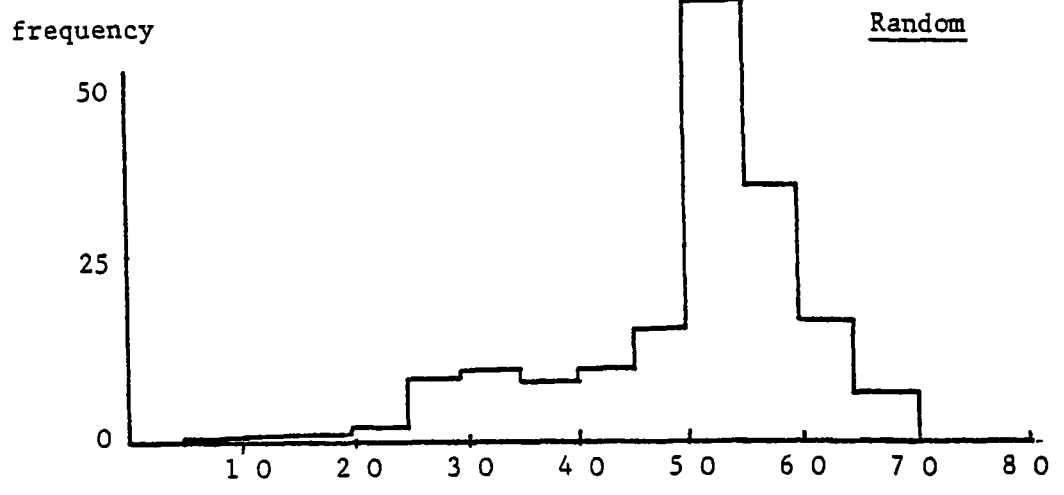
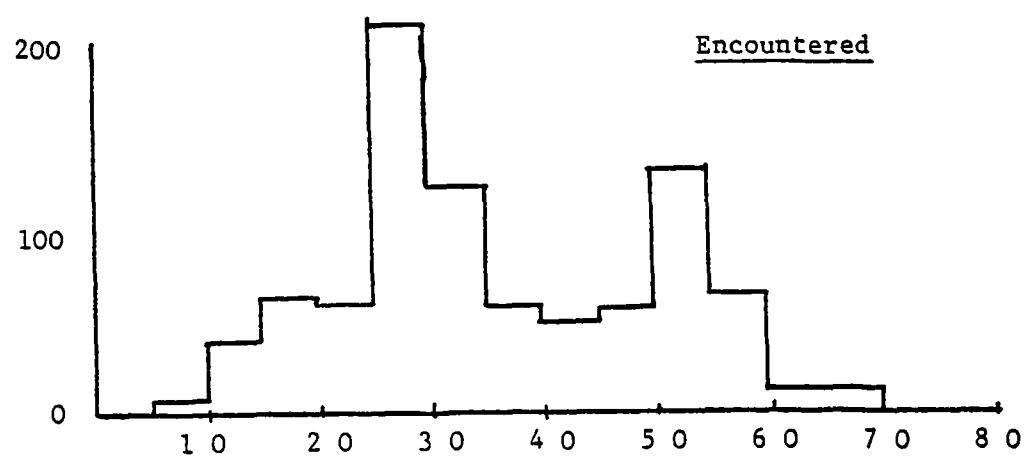

Fig 88

Density
 $n m^{-2}$



Shell length (cm)

Fig 89

from the random selection and energy maximization models (section 3.19.1) and the size distribution of shells opened by Oystercatchers (corrected for bias in the collection method - section 3.19.3) for typical upper and lower bed plots (section 2.2) are shown in Figs. 88 and 89, respectively. Selection of each class was assessed by calculating a selection index (SI_n).

$$SI_n = \frac{\text{the percent frequency of class } n \text{ in collected shells}}{\text{the percent frequency of class } n \text{ in environment}}$$

Variations in SI_n with mussel length, across all the plots and seasons where sufficient shells were collected to test the models are shown in Fig. 90, with the predicted inclusion points from the energy maximization models.

The pattern of selection was similar across all the plots. Although Oystercatchers selected preferentially the larger mussels ($SI_n > 1.0$), the point above which selection exceeded the selection expected if birds selected items in the proportion at which they were encountered ($SI_n = 1.0$, point B - Fig. 90) was always lower than the inclusion point predicted from the energy maximization model (= point A, Fig. 90). On average across all 13 sites the birds included a further 2.3 classes ($\sigma = 0.85$) beyond the model prediction.

In addition Oystercatchers did not totally reject all prey items below the observed inclusion point. Some prey were selected up to 5 classes below the observed, and 7 classes below the predicted, inclusion points. On average, the total rejection point (point C, Fig. 90) was 5.15 classes lower ($\sigma = 1.34$) than the predicted inclusion/rejection point from the energy maximization models.

Selectivity (SI_n) did not continue to increase beyond the observed

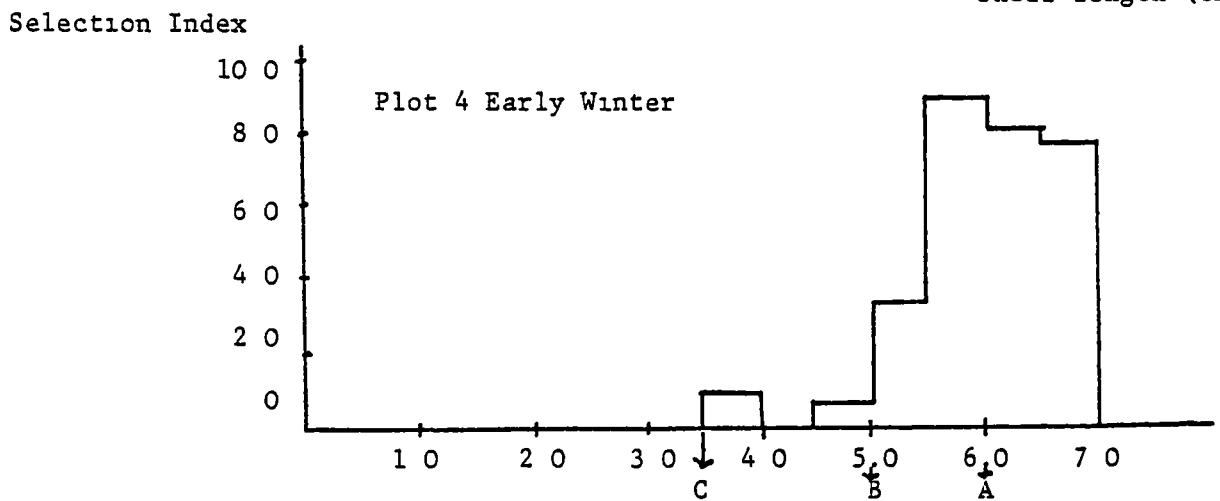
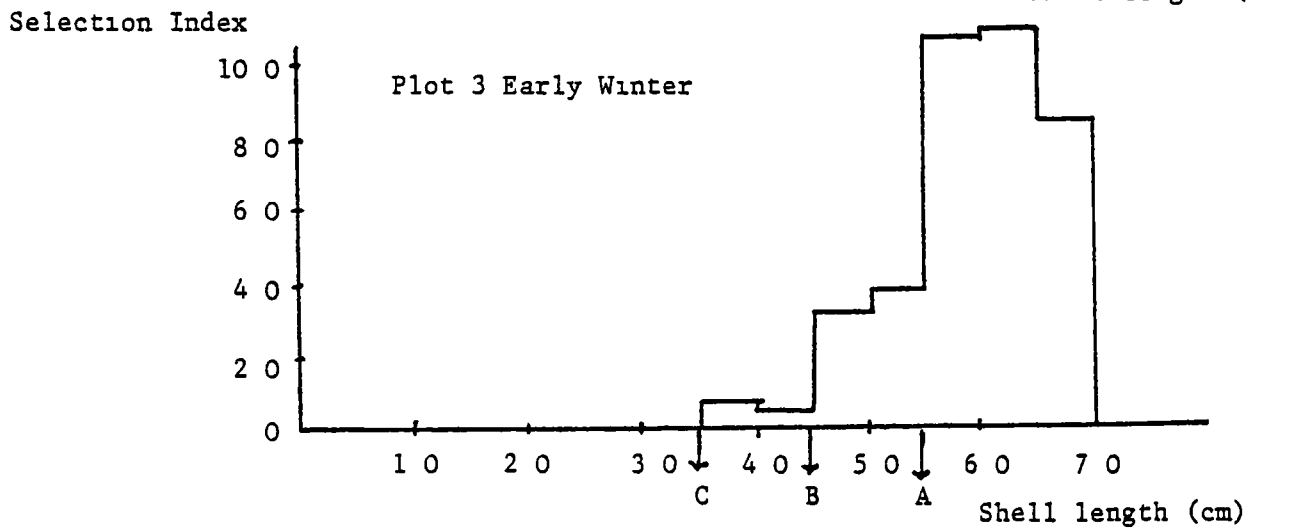
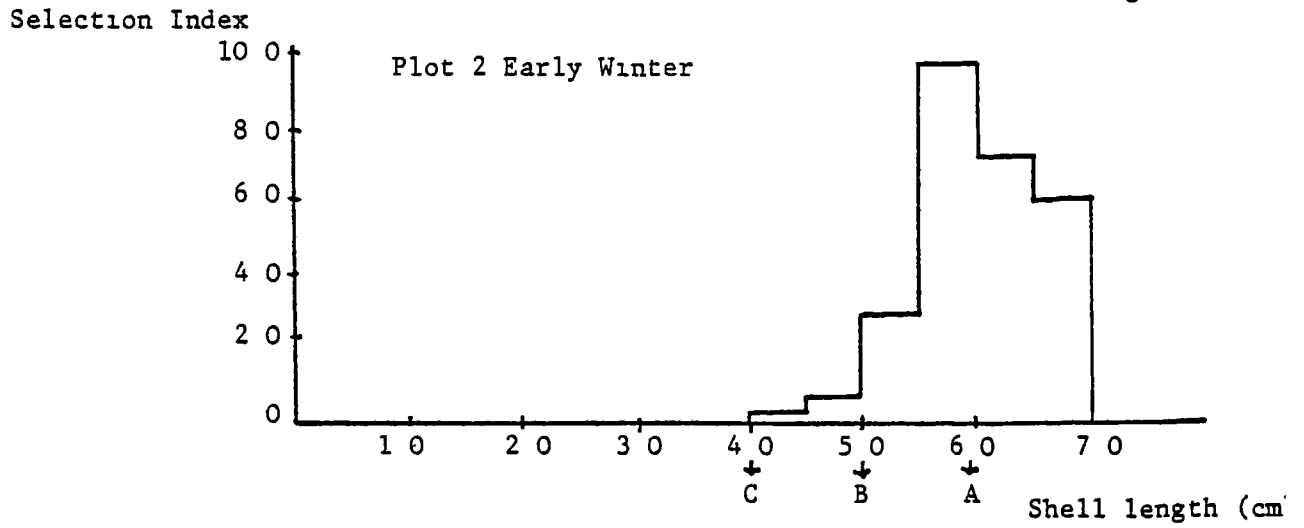
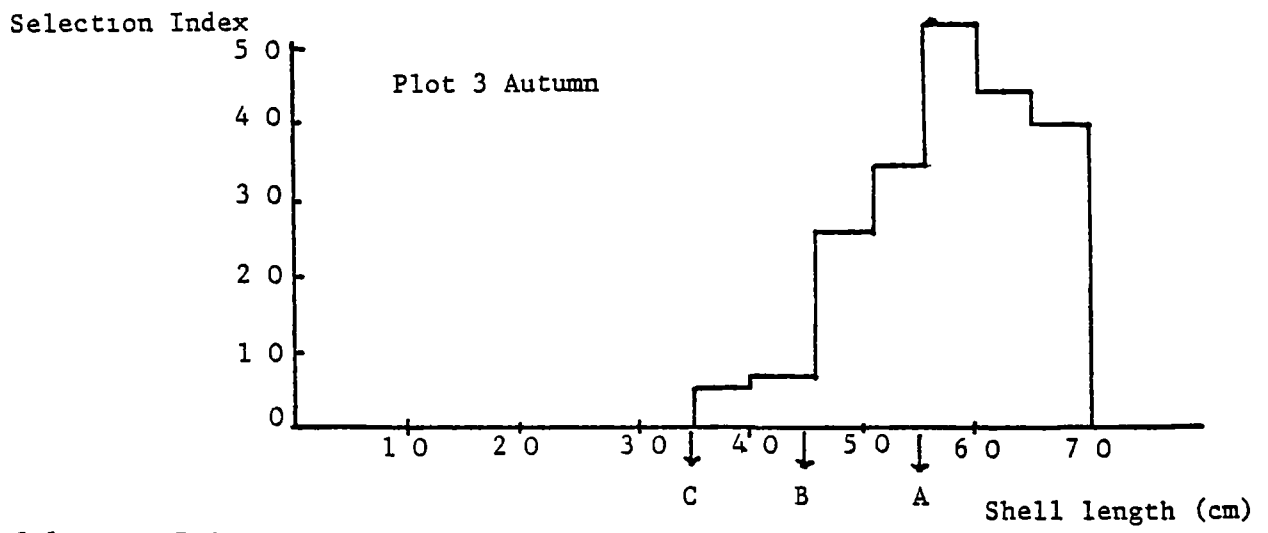
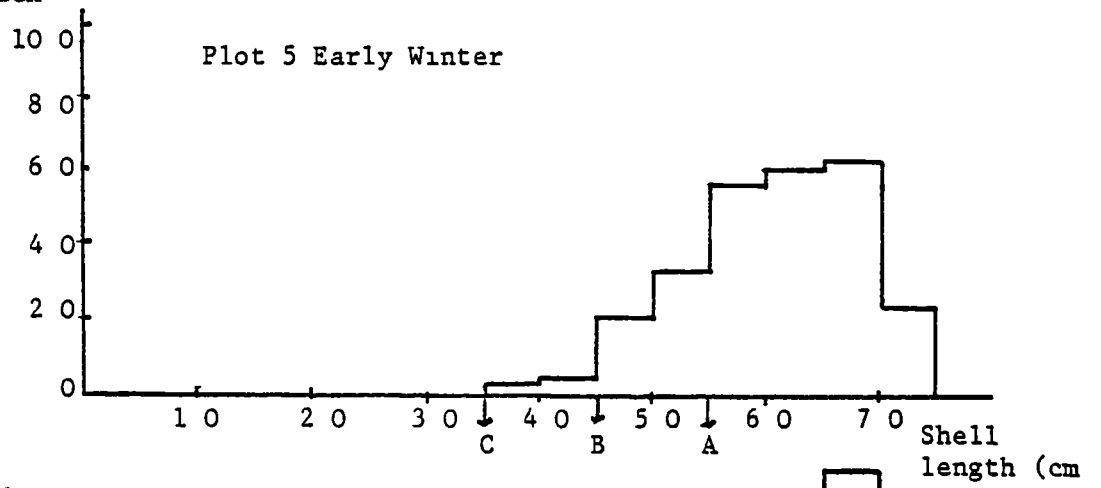

Fig 90

Shell length (cm)

Selection Index



Selection Index

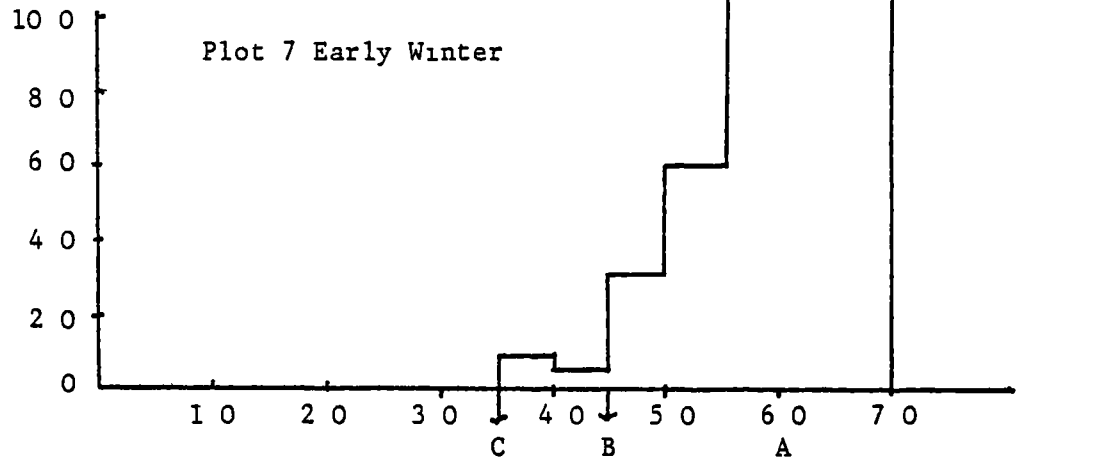

Selection Index

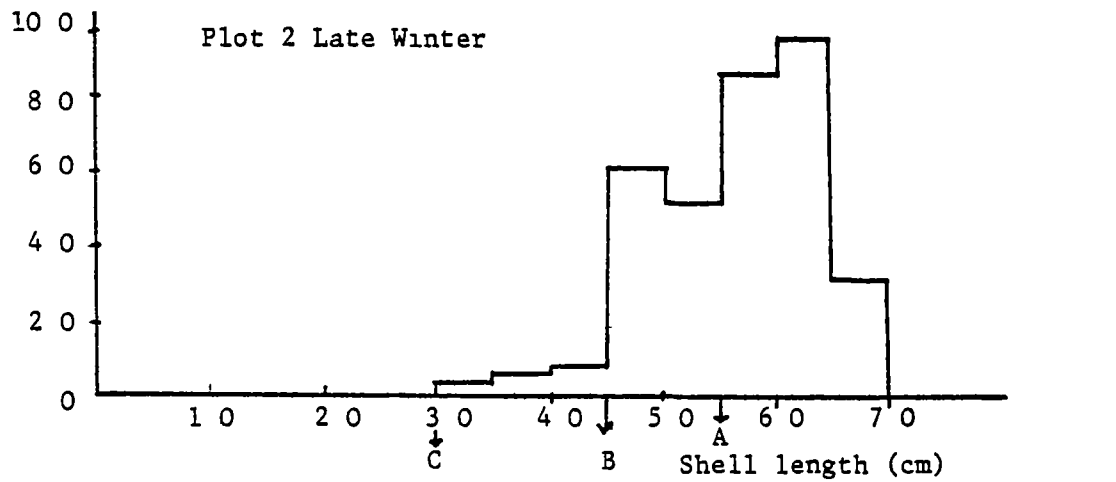

Selection Index

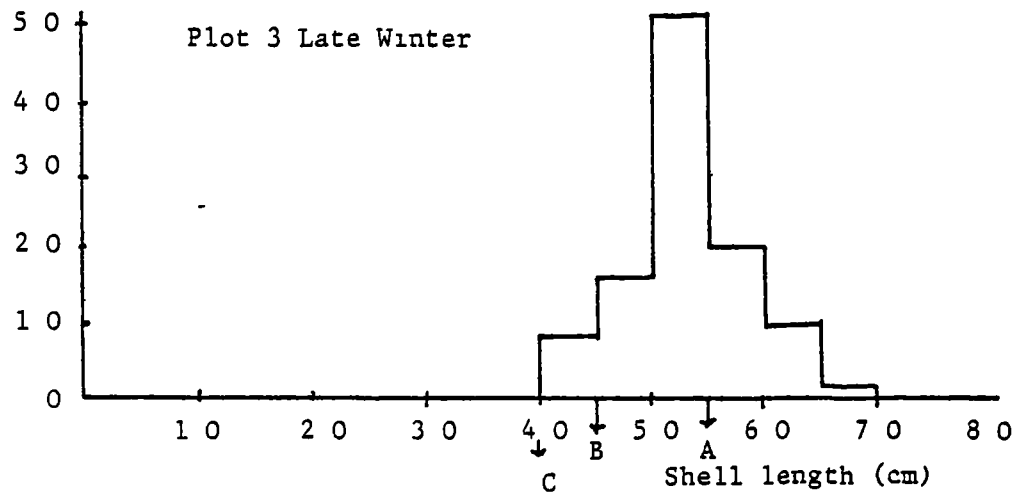

Fig 90 (contd)

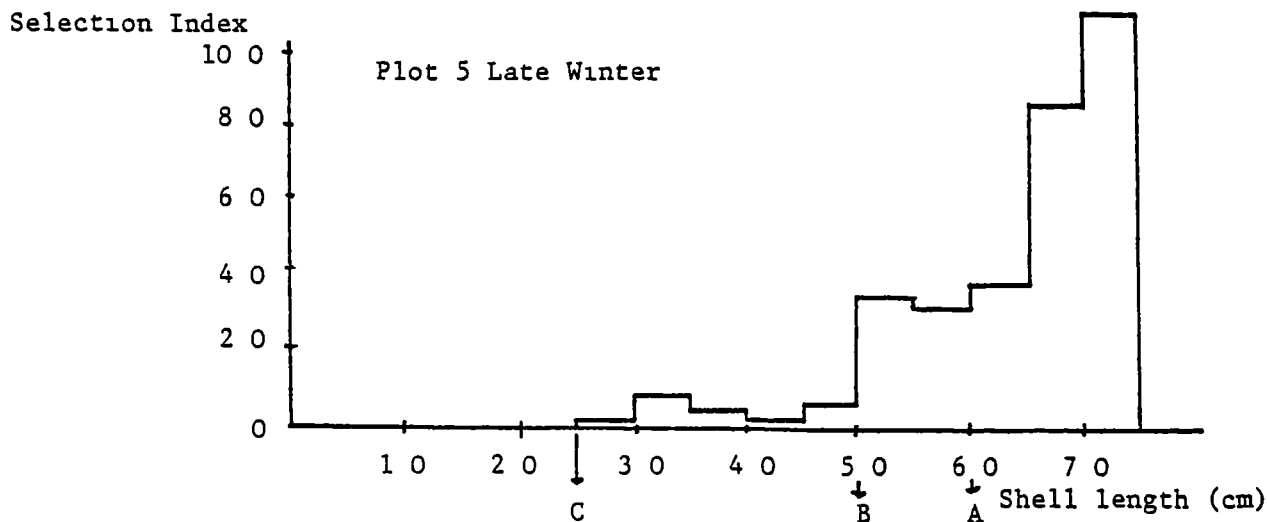

Fig 90 Selection index against mussel length at all sites in 'prizing' Oystercatchers. A value of the selection index greater than 10 represents selection, less than 10 represents under-selection and an index equal to 00 represents total rejection.

A = predicted point above which all classes should be included predicted by the maximization of gross and net energy gain models

B = observed point above which all classes are selected (SI > 10)

C = observed point below which all classes are rejected (SI = 0)

For plot locations, see section 2.2

Table 35

Differences between the observed intake of each size class of mussels by Oystercatchers, and the predictions of the random selection and energy maximization models, summed across all plots, for prizing Oystercatchers.

| <u>Midpoint</u> <u>Class</u> (cm) | Summed deviations from random prediction | Summed deviations from energy maximization |
|---|---|---|
| 0.75 | 0 86 | 0 |
| 1 25 | 3.21 | 0 |
| 1.75 | 6.43 | 0 |
| 2.25 | 15 86 | 0 |
| 2 75 | 35 81 | 0 |
| 3.25 | 54 58 | 7.69 |
| 3.75 | 52 79 | 24.1 |
| 4.25 | 95 45 | 43.73 |
| 4.75 | 1.85 | 161.7 |
| 5.25 | 145.0 | 380.23 |
| 5 75 | 91.37 | 1.04 |
| 6 25 | 48.9 | 208.5 |
| 6 75 | 69.9 | 297.13 |
| 7.25 | 17 39 | 101.6 |
| 7 75 | 5 02 | 22.2 |
| TOTAL | 644 02 | 1247.92 |

Difference between
random selection
prediction and
observed intake

OVER
SELECTION

UNDER
SELECTION

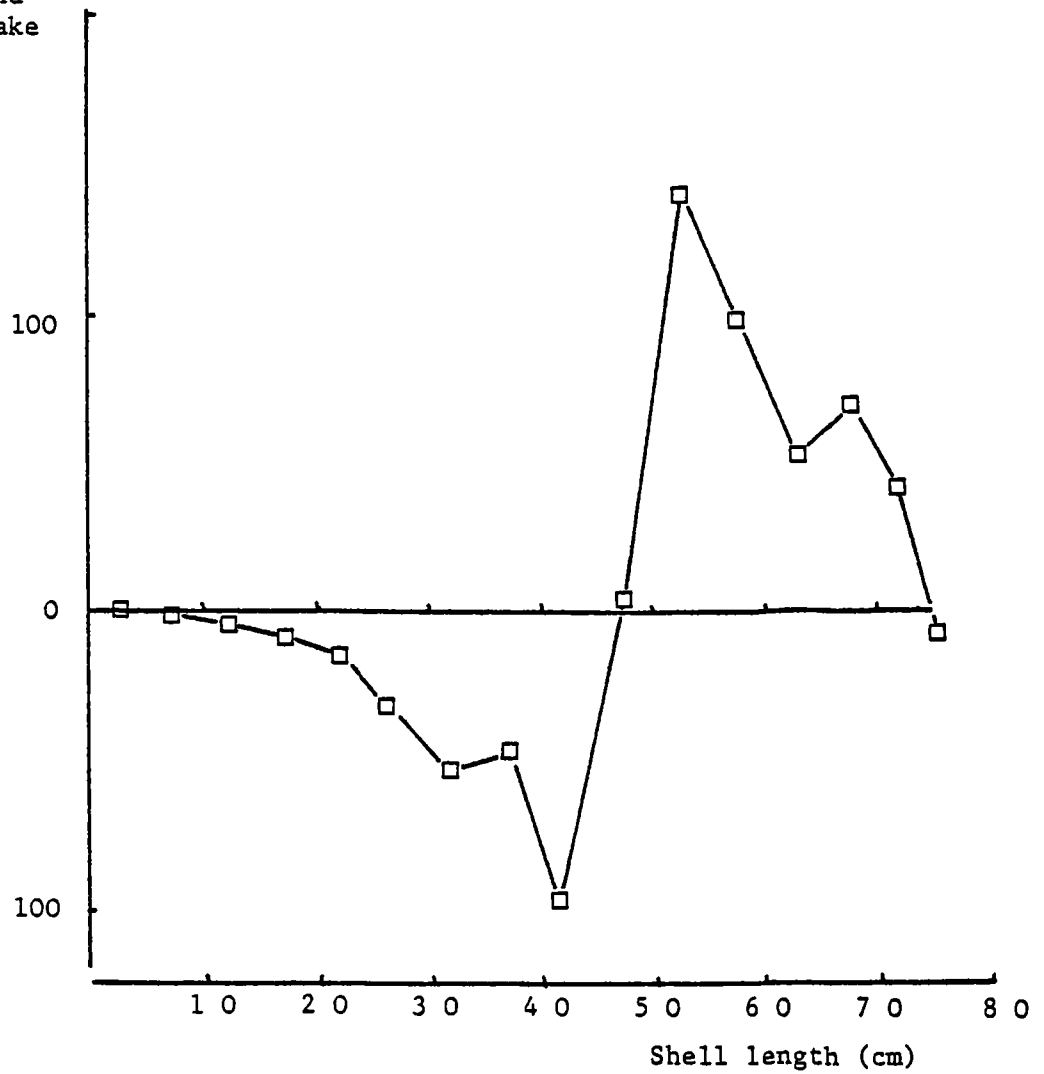

Fig 91

Difference between random selection prediction and observed intake of mussels by 'prizing' Oystercatchers, summed across all plots and seasons. Values above the line represent overselection, i.e. preference, whilst values below the line represent underselection.

inclusion point, to a maximum coinciding with the item of greatest profitability at all sites, but instead reached a maximum, on average, 1.23 classes below the greatest profitability class encountered (= largest class encountered), and decreased in the largest, most profitable, class.

The differences between observed percent frequencies ingested, and expected percent frequencies of each class, from each model (section 3.19.1), summed across classes at each site (Table 35) show this diet choice was closest to the random selection prediction.

Differences from the expected random diet were systematically related to mussel length. The difference between the observed percent frequencies of selection and that predicted by the random selection model, summed for each size class across all 13 plots are shown in Fig. 91. Prizing Oystercatchers still underselected small mussels (> 4.25 cm), and overselected larger mussels, when differences in relative size and exposure between sizes were accounted for. The most preferred mussels, however, 5.25 to 6.25 cm did not have the highest profitability (section 3.19)

(b) Hammering

The size distribution of mussels available, predicted intakes from both the random selection and energy maximization models, and the corrected size distribution of collected shells, for three sites at which sufficient numbers of hammered shells were collected to test the models, are shown in Figs. 92, 93 and 94.

Selection indices of each class against mussel lengths at all three sites are shown in Fig. 95, with the inclusion points predicted by the energy maximization hypothesis. As with prizing individuals, the point above which prey were selected ($SI_n > 1.0$) = point B was always lower than the predicted inclusion point. On average, across all three plots,

Figs 92, 93 and 94

Numbers of mussels of each size class encountered, predicted to be ingested by the random encounter model, the energy maximization model and observed ingested by 'hammering' Oystercatchers at all three plots where a large sample of hammered shells were collected

| | | |
|--------|--------|--------------|
| Fig 92 | Plot 7 | Early Winter |
| Fig 93 | Plot 2 | Late Winter |
| Fig 94 | Plot 5 | Late Winter |

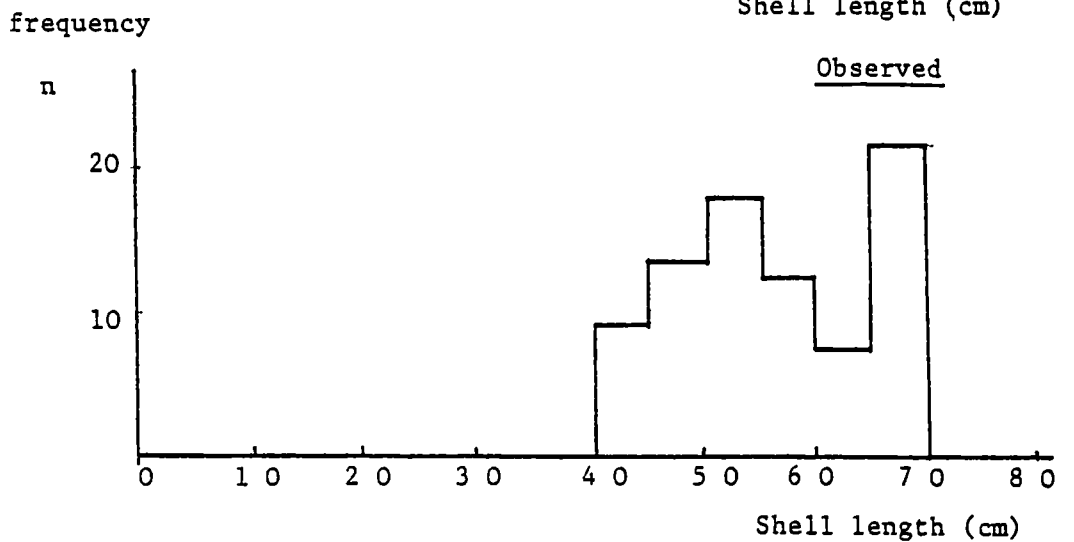
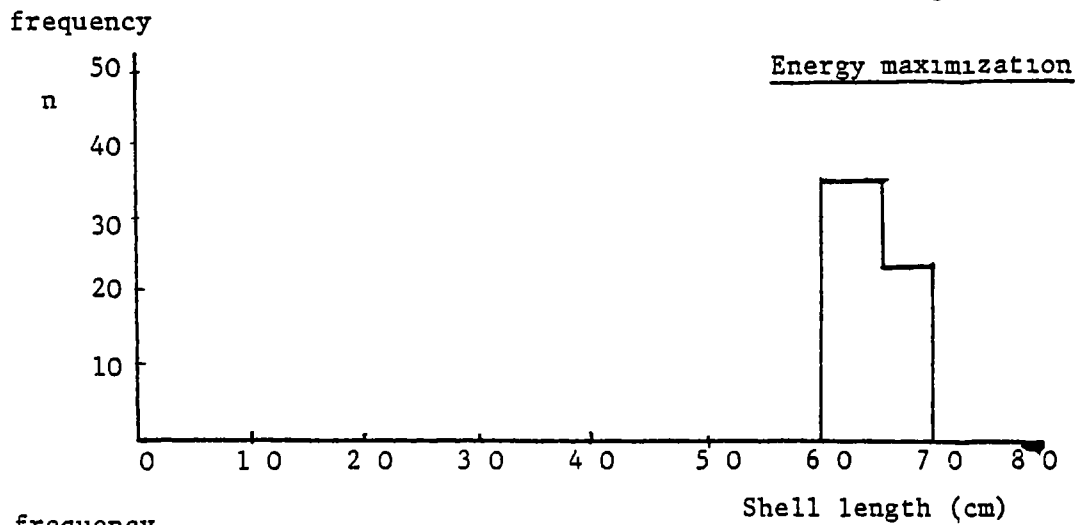
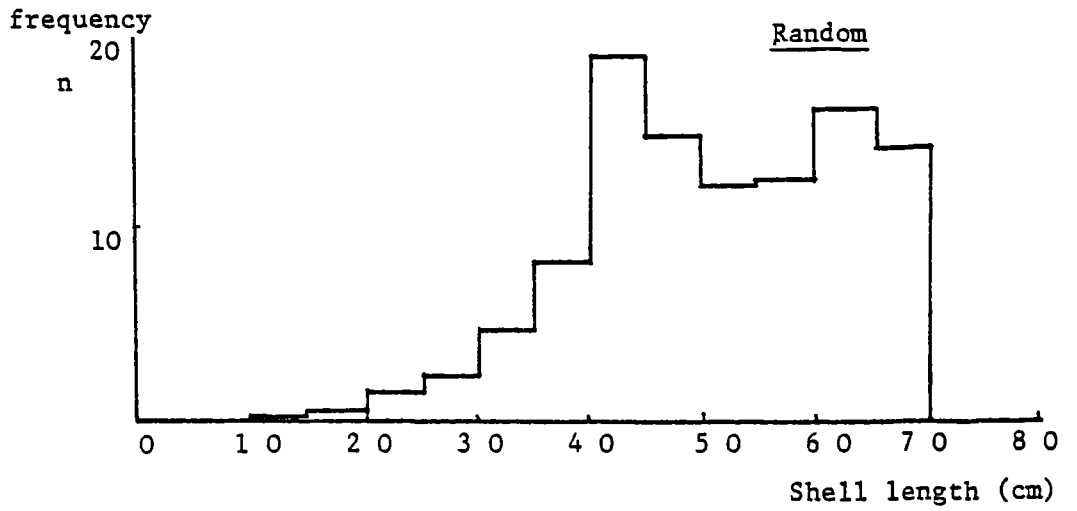
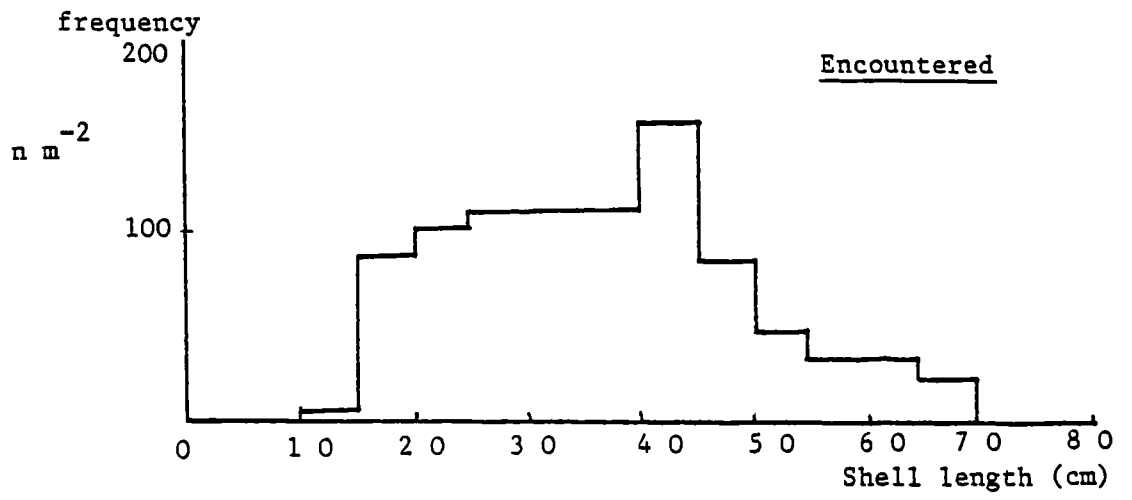

Fig 92

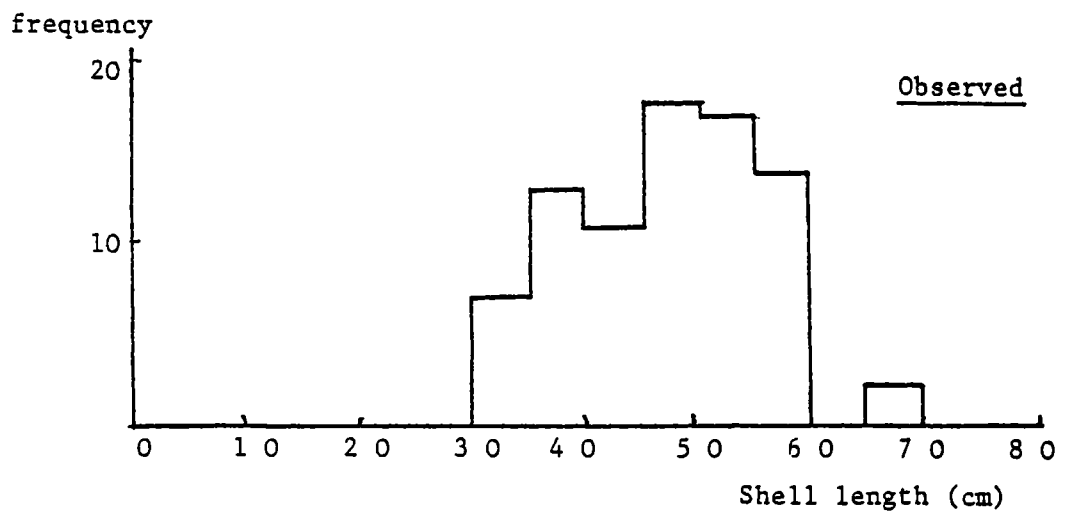
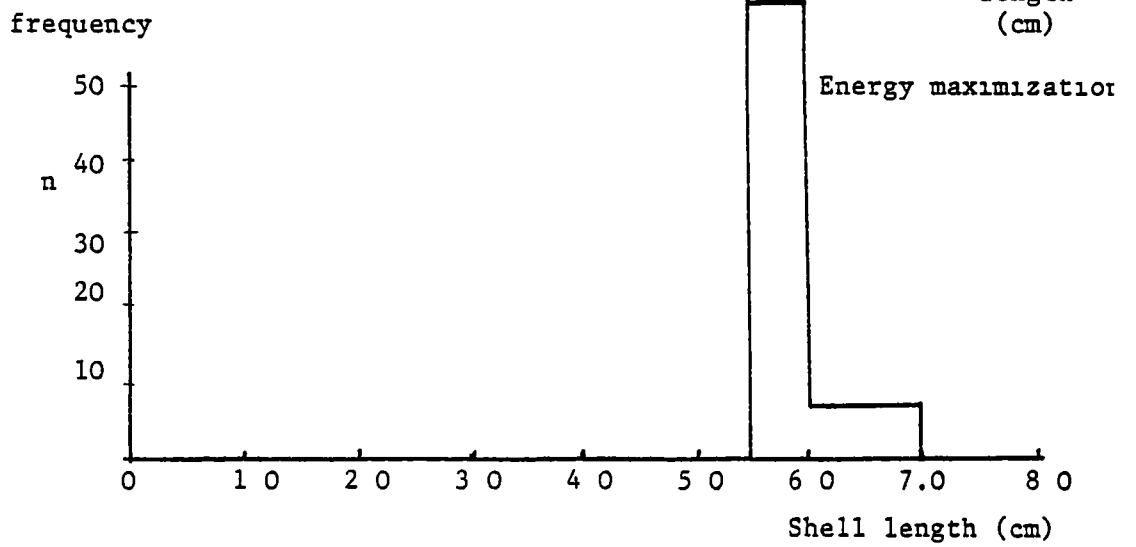
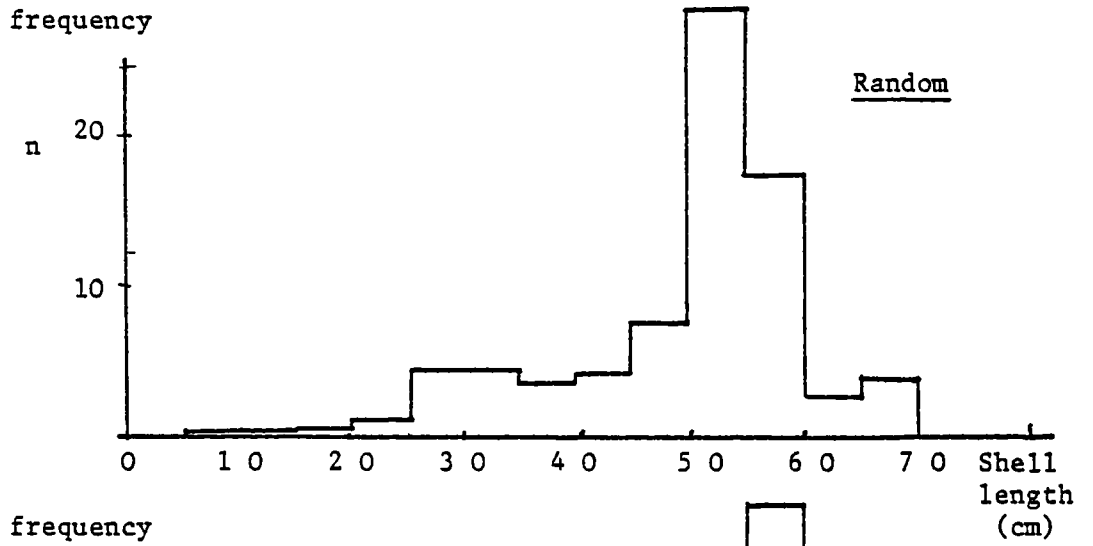
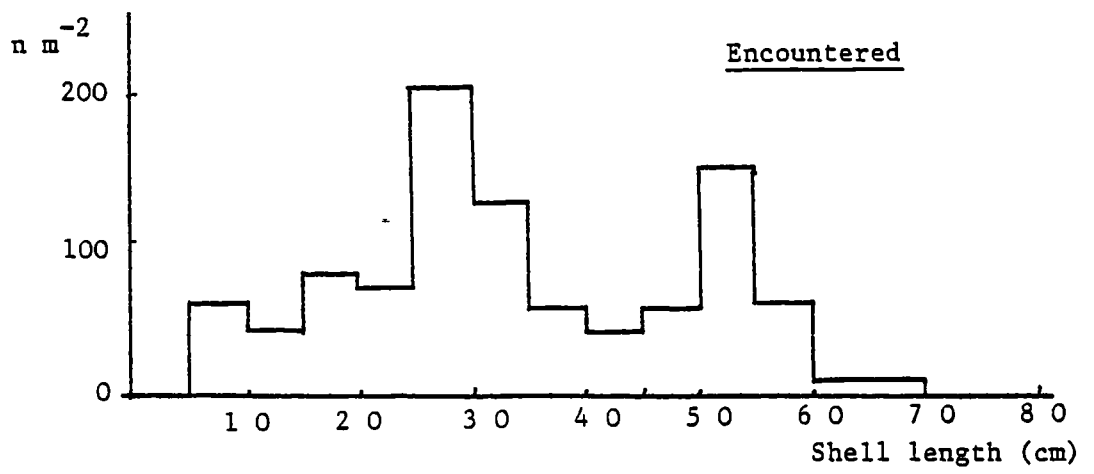

Fig 93

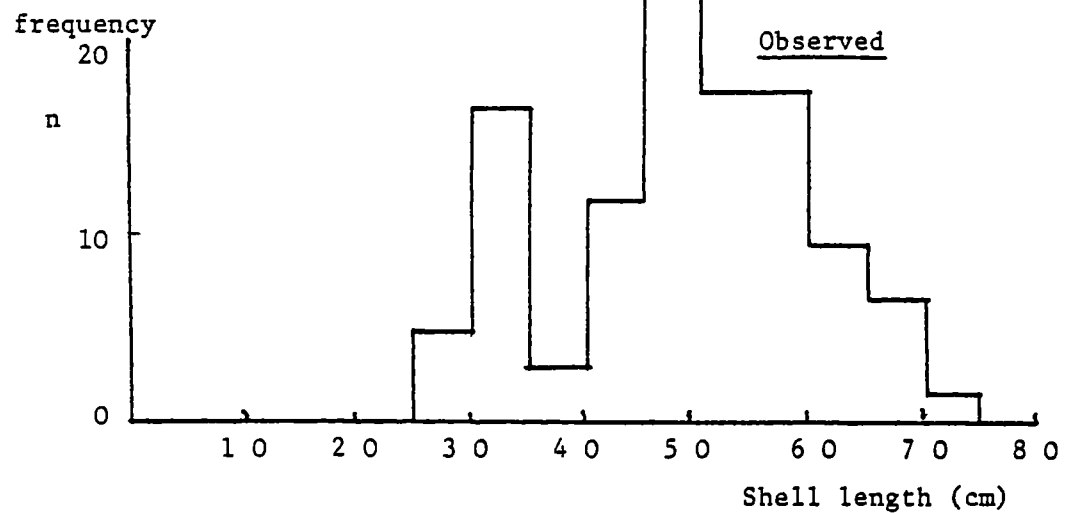
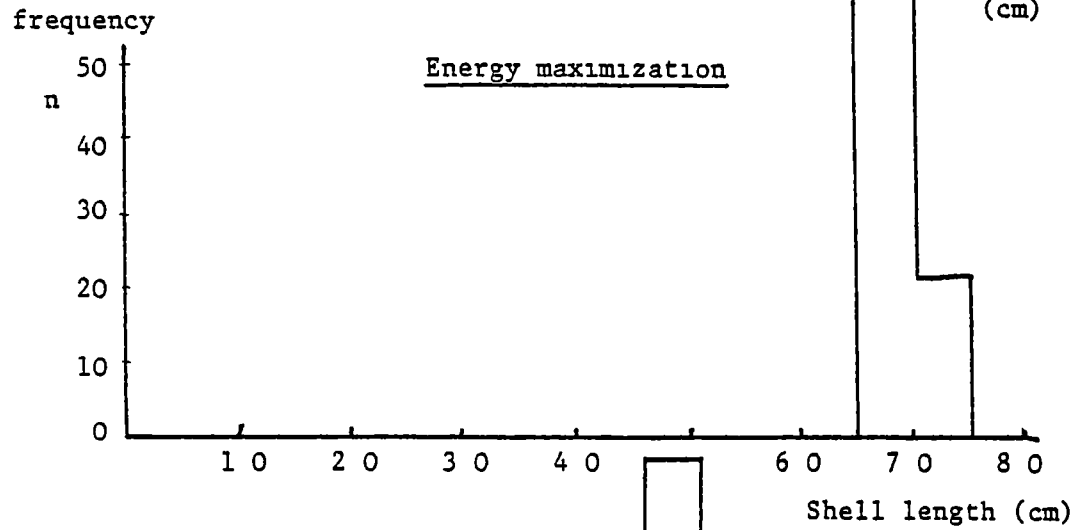
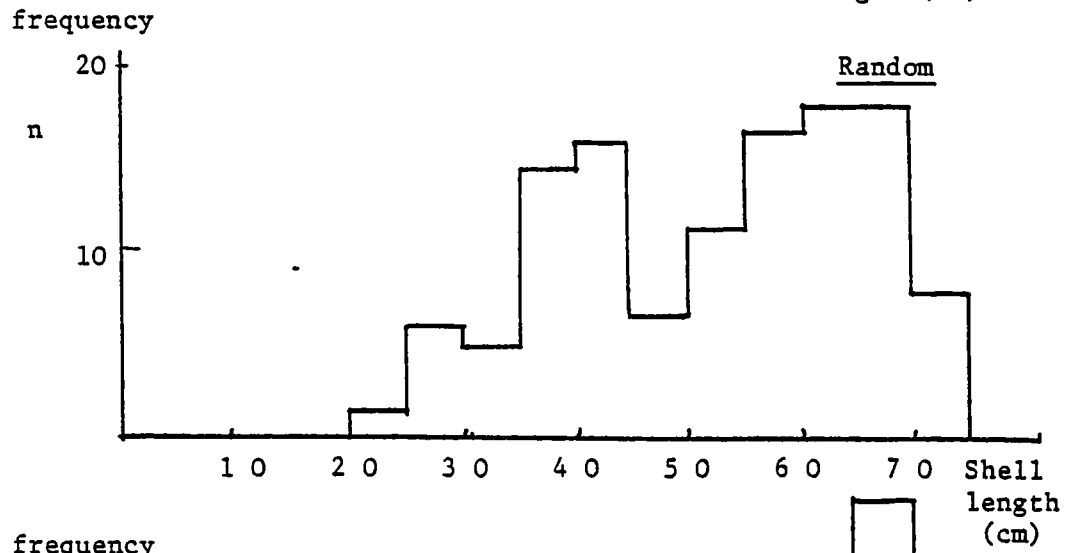
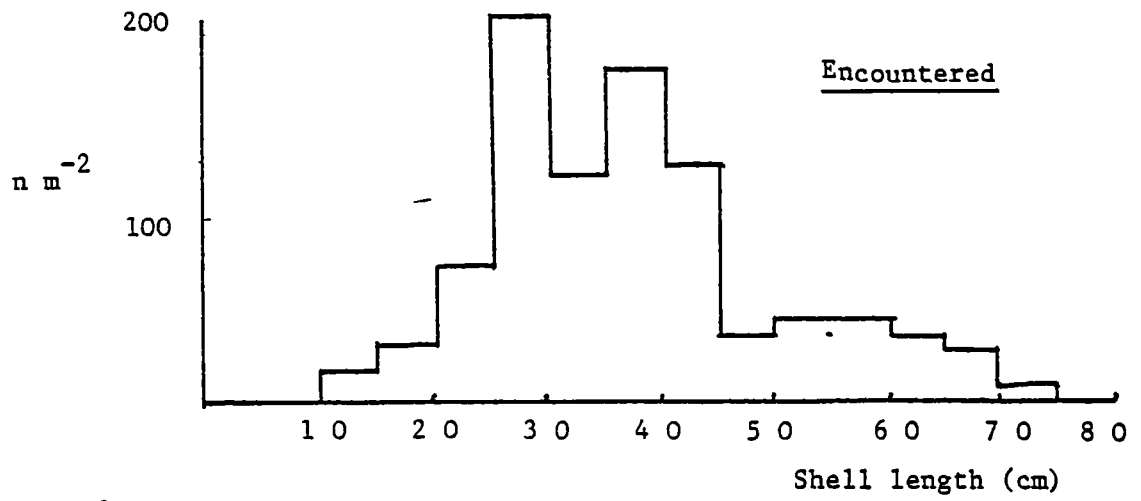

Fig 94

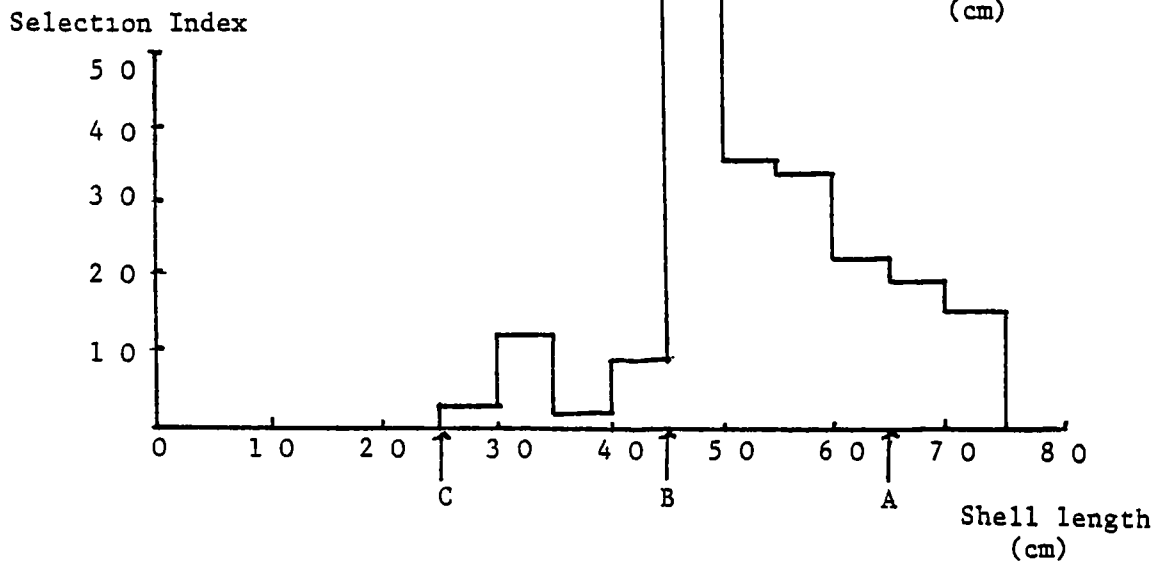
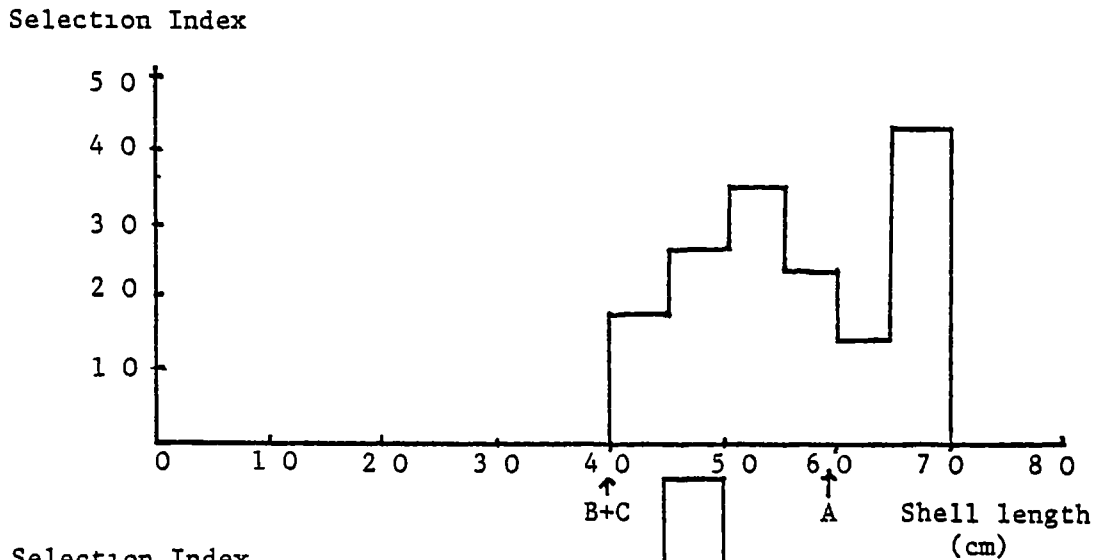
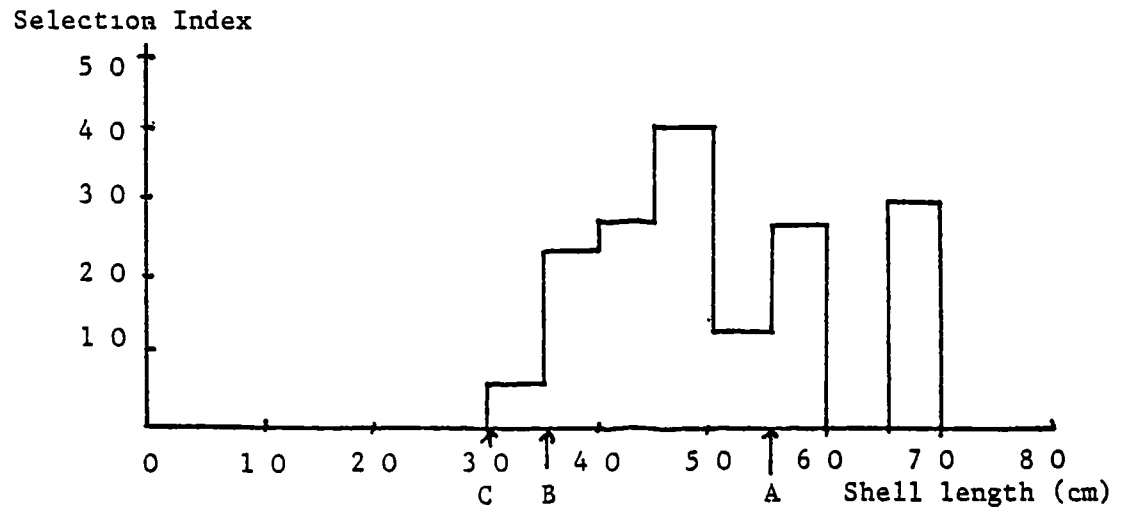

Fig 95

Selection index against mussel length at all sites in 'hammering' Oystercatchers. A value of the selection index greater than 1.0 represents selection, less than 1.0 represents under-selection and an index equal to 0.0 represents total rejection.

- A = predicted point above which all classes should be included predicted by the maximization of gross and net energy gain
- B = observed point above which all classes are selected (SI > 1.0)
- C = observed point below which all classes are rejected (SI = 0)

hammering individuals included 4 further classes beyond the model predicted inclusion point. Diets were significantly wider (n classes included) in hammerers compared with prizers at the same sites ($t = 2.74$, $p < .01$). In addition, at two of the sites the birds selected some prey beyond the observed inclusion point.

Differences between observed percent frequencies ingested, and the expected percent frequencies of each class from each model, summed across classes, at each site (Table 36) show overall diet choice was closest to the random selection prediction. Differences from the random prediction varied with body length (Fig. 96). Hammerers underselected mussels less than 3.75 cm and overselected mussels between 4.25 and 5.25 cm, but underselected larger mussels (> 5.25 cm) which were also the mussels of highest profitability.

(3.19.5) Relationship between the adductor muscle scar dimensions and the mass of the adductor muscle

Large mussel shells had large adductor muscle scars (Appendix 1), and contained animals with heavy posterior adductor muscles. The product of the two muscle scar dimensions (Appendix 1) also entered a multiple regression, with adductor muscle mass as the dependent variable and shell length as the independent variable, as a significant second predictor (Table 37). Shells of the same length with different sized adductor muscles also had different sized adductor muscle scars.

Although the adductor muscle consisted of between 10 and 25% of the total dry flesh mass (section 3.4) the product of the two muscle scar dimensions did not explain any of the residual variability in a regression of flesh AFDM with shell length. Mussels with large adductor muscles did not also have a large flesh AFDM for their length.

Table 36

Differences between the observed intake of each size class of mussels by Oystercatchers, and the predictions of the random selection and energy maximization models, summed across all plots, for hammering Oystercatchers

| Mid Point Class (cm) | Summed deviations from random prediction | Summed deviations from energy maximization |
|----------------------------|---|---|
| 0.75 | 0.01 | 0 |
| 1.25 | 0.25 | 0 |
| 1.75 | 0.63 | 0 |
| 2.25 | 1.93 | 0 |
| 2.75 | 2.71 | 0 |
| 3.25 | 7.15 | 3.57 |
| 3.75 | 3.03 | 12.5 |
| 4.25 | 7.59 | 10.8 |
| 4.75 | 22.63 | 52.2 |
| 5.25 | 1.01 | 101.7 |
| 5.75 | 0.41 | 34.5 |
| 6.25 | 8.65 | 36.3 |
| 6.75 | 8.65 | 91.7 |
| 7.25 | 3.28 | 19.1 |
| 7.75 | 0 | 0 |
| TOTAL | 67.01 | 362.37 |

Difference between
random selection prediction
and observed intake

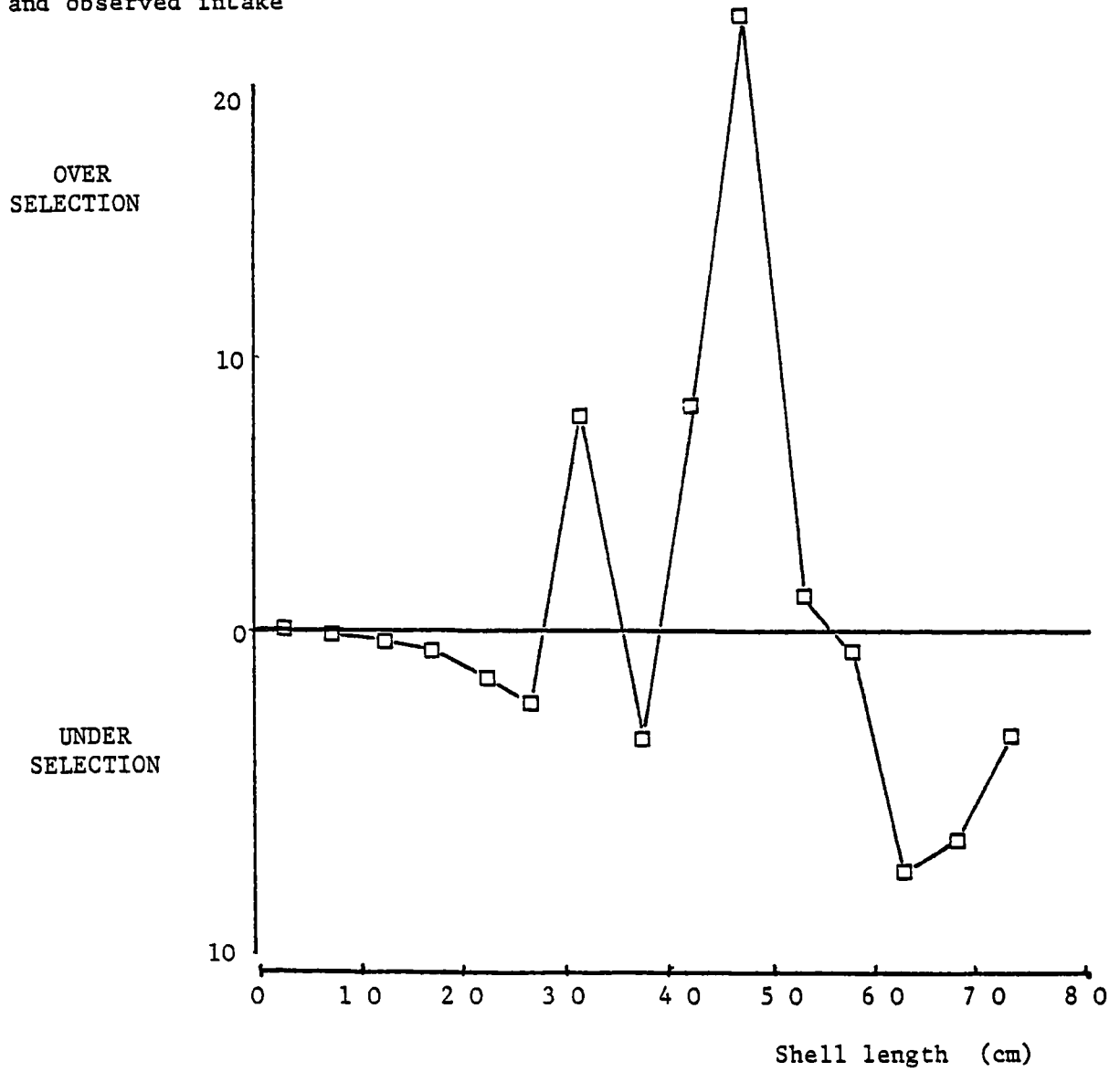

Fig 96 Difference between random selection prediction and observed intake of mussels by 'hammering' Oystercatchers, summed across all plots and seasons. Values above the line represent overselection, i.e. preference, whilst values below the line represent underselection.

Table 37

Results of a multiple regression analysis of wet mass of the posterior adductor muscle of Mytilus as the dependent variable against shell length and log product of the muscle scar dimensions (Appendix 1) as independent variables.

| Independent Variable | Coefficient | σ Coefficient | t |
|---|-------------|----------------------|-------|
| Log _e Shell length | 0 605 | 0 05 | 11 83 |
| Log _e product of scar dimensions | 0.878 | 0.022 | 39.91 |
| Constant | -1.0 | 0.04 | 25.0 |

| Analysis of variance | | n = 31 | | |
|----------------------|------|--------|-------|--------|
| Source | SS | MS | F | p |
| Regression | 3 26 | 1 63 | 139.1 | < .001 |
| Shell length | 3.09 | 3.09 | 263.7 | < .001 |
| Muscle scar | 0 18 | 0 18 | 15 7 | < .01 |
| Residual | 0 29 | 0 01 | | |

(3.19.6) Relationship between dry shell mass, shell thickness and shell length

The thicknesses of a random sample of shells, across sites, seasons and sizes, at the posterior ventral and dorsal surfaces, were intercorrelated. Correlations between each thickness measure and dry shell mass (section 3.4) were similar ($r = 0.649, 0.64$ and 0.647 for posterior, ventral and dorsal thicknesses respectively).

Thickness on the posterior margin entered a stepwise multiple regression, with dry shell mass as the dependent variable and shell length as the independent variable, as a significant second predictor (Table 38). Variation in the other thickness measures did not explain significant amounts of the residual variability and were excluded.

(3 19.7) Preference for prey within size classes

Partial preference for prey within size classes was investigated at nine sites in prizing Oystercatchers. At each site the following prey characteristics - shell height, shell width (Appendix 1), dry shell mass (section 3.4), product of the adductor muscle scar dimensions (Appendix 1 and section 3.19.5) and percentage of the shell covered with barnacles, were measured in all the mussels opened by Oystercatchers. They were compared with the expected value of each characteristic, predicted from relationships between each characteristic and shell length in mussels collected from the environment at each site.

(a) Relationships between shell characteristics and shell length at each site

For all variables, the relationship between the variable and size, at all plots on each mussel bed, were not significantly different. Data from each bed were therefore pooled

Table 38

Results of a multiple regression analysis of dry shell mass of Mytilus (g) as the dependent variable against shell length and shell thickness on the posterior margin as independent variables

| Independent Variable | Coefficient | σ Coefficient | t |
|----------------------|-------------|----------------------|--------|
| Length (cm) | 5 37 | 0.32 | 16.9 |
| Thickness | 5 43 | 0.66 | 8.04 |
| Constant | -25.5 | 1.83 | -13.86 |

n = 49

Analysis of variance

| Source | SS | MS | F | p |
|------------|---------|--------|--------|--------|
| Regression | 1115.48 | 557.74 | 264.33 | < 001 |
| length | 978.79 | 978.79 | 463.88 | < .001 |
| thickness | 136 69 | 136 69 | 66 01 | < 001 |
| residual | 99 17 | 2 11 | | |

(1) Adductor muscle dimensions and shell length

On each bed there was a positive curvilinear relationship between the product of the muscle scar dimensions and shell length (Table 39).

(ii) Shell mass and shell length

(See section 3.4).

(iii) Barnacle coverage and shell length

There was a positive curvilinear relationship between the percentage of shell surface covered with Barnacles and shell length on each mussel bed (e.g. Fig. 97) (Table 39).

(iv) Relationships between shell height, shell width and shell length

Significant non-linear relationships were established between all three allometric variables at each site (Table 39).

(b) Comparison of shell characteristics in environmental mussels with those selected by Oystercatchers

Observed values of each shell characteristic in mussels selected by Oystercatchers, and predicted values from mussels in the environment, were compared with two sample t-tests (Table 40). At all nine sites the mussels selected by prizing Oystercatchers had significantly smaller than predicted adductor muscle scars, and hence smaller adductor muscles (section 3.19.4). At six of the seven sites where coverage of Barnacles was measured, Oystercatchers selected mussels with significantly fewer barnacles on the shell surface. Shell masses were not significantly different and therefore selected shells were not thinner or thicker from the expected, at all nine sites. Shell widths did not differ significantly from the expected at seven of the nine sites. At the remaining two sites shells selected by Oystercatchers were significantly narrower. Selection for shells of different heights were significant at five of the nine sites: at four of these, shells which were significantly

Table 39

Coefficients and constants from regression equations relating various shell characteristics with shell length (cm) of mussels, on each mussel bed in Late Winter

| Variable | Bed | Constant | Coefficient | r ² | n | Equation ¹ Type |
|---|-----|----------|-------------|----------------|----|-------------------------------|
| Width (cm) | U | -1.10 | 1.11 | 95.0 | 30 | LOG |
| | L | -1.04 | 1.15 | 93.8 | 56 | LOG |
| Height (cm) | U | -0.492 | 0.912 | 98.6 | 30 | LOG |
| | L | -0.74 | 1.02 | 85.9 | 56 | LOG |
| Product of Muscle scar Dimensions (mm ²) | U | -4.09 | 2.28 | 94.0 | 30 | LOG |
| | L | -3.56 | 1.95 | 83.5 | 39 | LOG |
| Shell Mass (g) | U | -3.12 | 3.22 | 98.8 | 30 | LOG |
| | L | -3.54 | 3.47 | 97.6 | 56 | LOG |
| Barnacle Coverage (%) | U | -5.38 | 5.48 | 54.4 | 23 | LOG |
| | L | -5.91 | 5.27 | 46.7 | 24 | LOG |

¹ LOG - all variables transformed to log_e

Percent of shell surface covered with barnacles

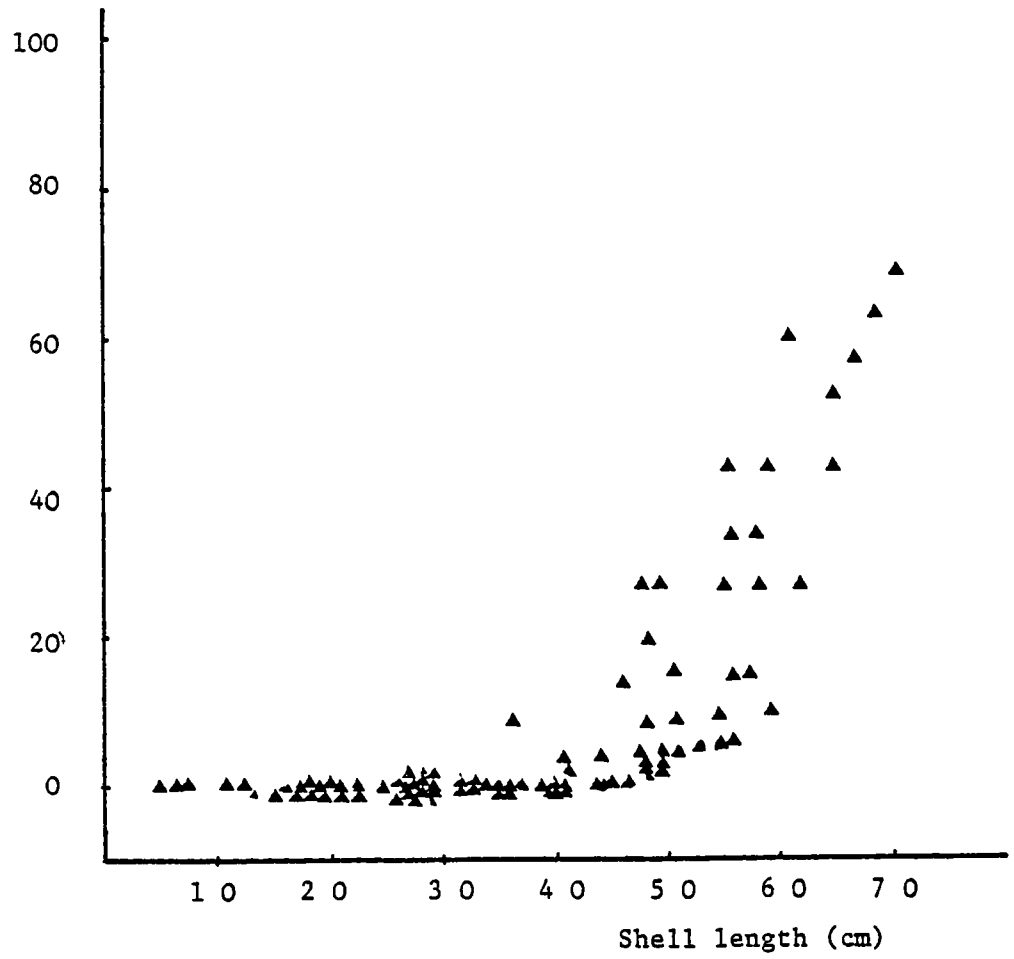

Fig 97 Percent of mussel shell surface covered with Barnacles (Balanus sp) against mussel shell length (example plot 3, Late Winter)

Table 40

Comparison of predicted values of mussel shell characteristics from regressions relating shell length characteristics in mussels from the environment to the observed values of the characteristics in mussels selected by Oystercatchers (using paired sample t-tests).

| Plot | Bed | Shell Width | Shell Height | Shell Mass | Characteristic Log product of mussel scar dimensions | Barnacle Coverage | <u>df</u> |
|-------|-----|--|---------------|---------------|---|----------------------|-----------|
| 2 | U | -2.26 ^{1,4} 0.025 ² | -1.03 0.29 | -1.27 0.21 | -8.75 .0001 | -7.69 .0001 | 113 |
| 4 | U | -1.81 0.07 | -6.38 .001 | -1.01 0.31 | -9.58 .0001 | -15.04 .001 | 309 |
| 3 | U | -1.75 0.084 | 3.67 0.01 | -1.21 0.23 | -6.59 .001 | -9.1 .001 | 77 |
| 2(EW) | U | -0.9 0.37 | -2.06 0.04 | -2.61 0.01 | -5.11 0.01 | -13.01 .001 | 143 |
| 3(EW) | U | -2.2 0.034 | -2.21 0.03 | -1.28 0.21 | -6.39 0.01 | nm ³ | 40 |
| 7 | L | 1.38 0.17 | -0.59 0.56 | 0.63 0.53 | -3.26 0.0016 | -1.47 0.15 | 86 |
| 5 | L | -0.59 0.56 | -0.67 0.5 | 0.32 0.75 | -4.16 0.001 | n.m. | 121 |
| 9 | L | 1.73 0.086 | 1.48 0.14 | -1.21 0.23 | -3.48 0.01 | -3.25 0.0015 | 127 |
| 8 | L | 0.05 0.96 | 4.23 .001 | -0.91 0.37 | -4.95 0.01 | -2.09 0.039 | 120 |

4 Note a -ve value indicates Oystercatchers selected smaller characteristics, +ve indicates larger

- 1 upper value = t
- 2 lower value = p
- 3 nm = not measured

shorter were selected whilst at the fifth site mussels with significantly taller shells (Appendix 1) were selected.

(3.19.8) Spatial heterogeneity in density within plots

Estimates of density of each size class from six separate places within one plot (upper bed, plot 3) were entered as the dependent variable in a two-way analysis of variance with classes and places as the independent variables. Densities were significantly different between classes, but not significantly different between places (Table 41), suggesting spatial heterogeneity in density was relatively unimportant within the plots.

(3.20) Spatio-temporal exploitation patterns

(a) Redshank

Numbers of Redshank foraging in the upper and lower shore levels of Culross bay and roosting on the Longannet power station ash pans (LAPS) (section 2.2 Figs. 4,5), from six hours before to six hours after high tide averaged across three spring tides in Early Winter are shown in Fig. 98.

The roost at LAPS averaged 350 birds throughout the high tide period. The total on Culross bay was relatively stable throughout the low tide period at between 180 - 200 birds, all of which roosted at LAPS. Between two and three hours before low water, as the upper shore became exposed, all the Culross birds left LAPS and fed at the upper shore. As the lower shore became exposed, birds moved away from the upper shore until at low water approximately 50 birds remained on the upper shore with 120 on the lower shore. After low water, numbers on the lower shore gradually declined as some birds returned to the upper shore. Between 3 and 4 hours after low tide the lower shore was covered

Table 41

Analysis of variance of mean density of Mytilus edulis across fourteen size classes and six locations within a single plot on the upper mussel bed at Culross

| Variable | df | SS | MS | F | p |
|----------|----|---------|-------|------|--------|
| Sizes | 13 | 435356 | 33489 | 3.55 | < .001 |
| Location | 5 | 59590 | 11918 | 1.26 | < .05 |
| error | 65 | 612816 | 9428 | | |
| | 83 | 1107762 | | | |

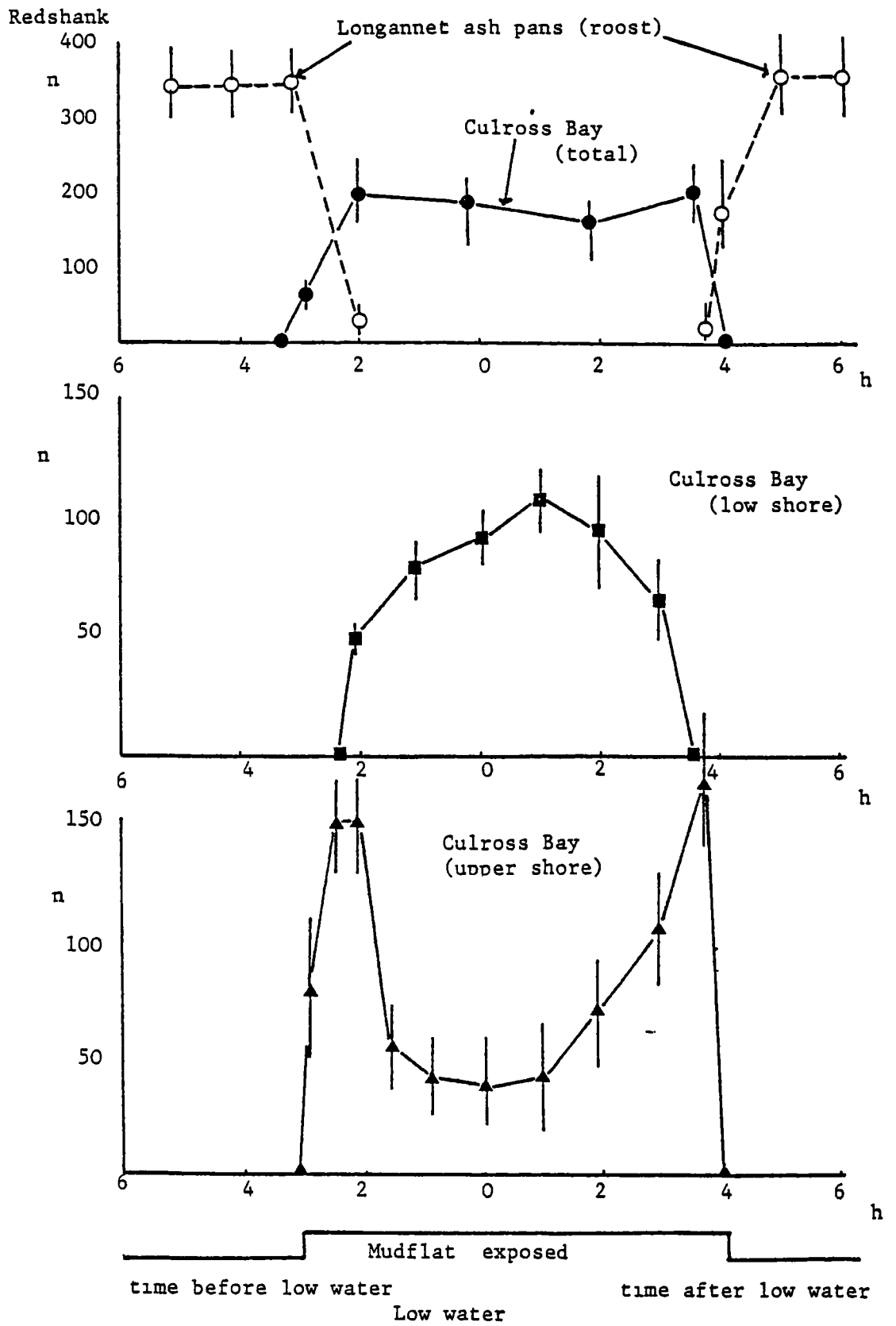

Fig 98 Numbers of Redshank roosting at Longannet ash pans (open symbols) and numbers foraging in Culross Bay (closed symbols), averaged over three spring tides in Spring (+ ranges), throughout the tidal cycle

by the advancing tide and all the remaining birds on the lower shore transferred to the upper shore. Over the next half hour, all the birds on the upper shore flew to LAPS, as the upper shore was covered by the tide.

(b) Oystercatchers

The total Oystercatcher population in the Culross bay, in Winter, varied between 90 and 100 birds. These birds were divided between three roosting sites (LAPS, High Valleyfield ash pans HVAPS, and the end of the pier - see Figs. 4 and 7) and four feeding sites (Inland field, upper and lower mussel beds and the open mudflats) - see section 2.2. Fluctuations in the numbers feeding and roosting at each site, throughout the whole tidal cycle, averaged across three spring tides in Early Winter are shown in Fig. 99.

At low tide the majority (c. 55) of birds fed on the lower bed with approximately 15 on the upper bed, and 10 (mostly juveniles) on the open mud flat. This pattern remained stable until approximately two hours after low water. Birds on the lower bed then began to leave directly to LAPS with some transferring to the upper mussel bed. Over the next two hours, as the lower bed became covered, this process continued and a few lower bed with more upper bed birds, left to feed on inland fields. Throughout this period the population of juveniles feeding on the flat remained constant. As the tide continued to rise the inner bed birds transferred to the inland fields, whilst the last of the outer bed birds left to LAPS and HVAPS. The juveniles either also left to the inland fields or fed on the rocks at the top of the shore. Between four and six hours after low water the inland feeding birds, with the juveniles from the rocks, flew to roosts at HVAPS and the pier end. Some juveniles roosted at LAPS.

Oystercatchers

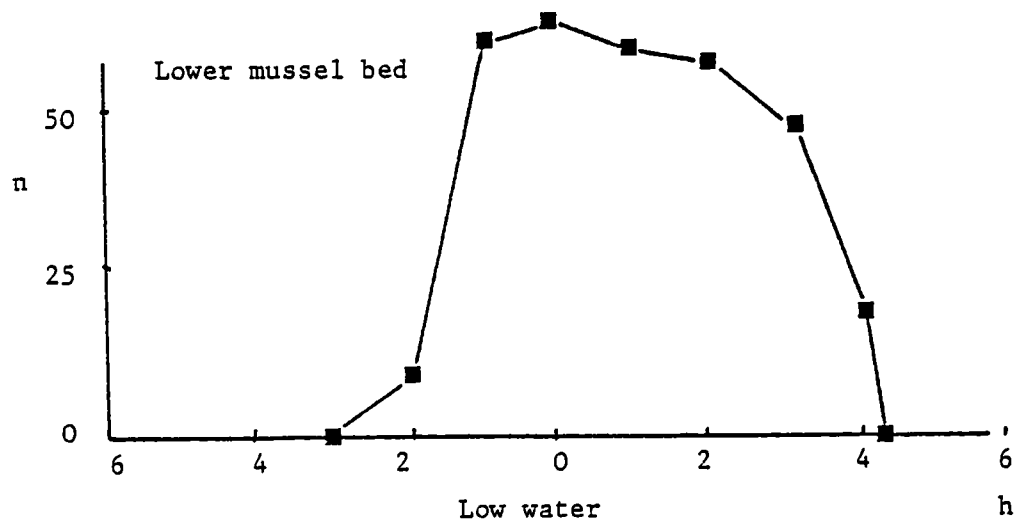
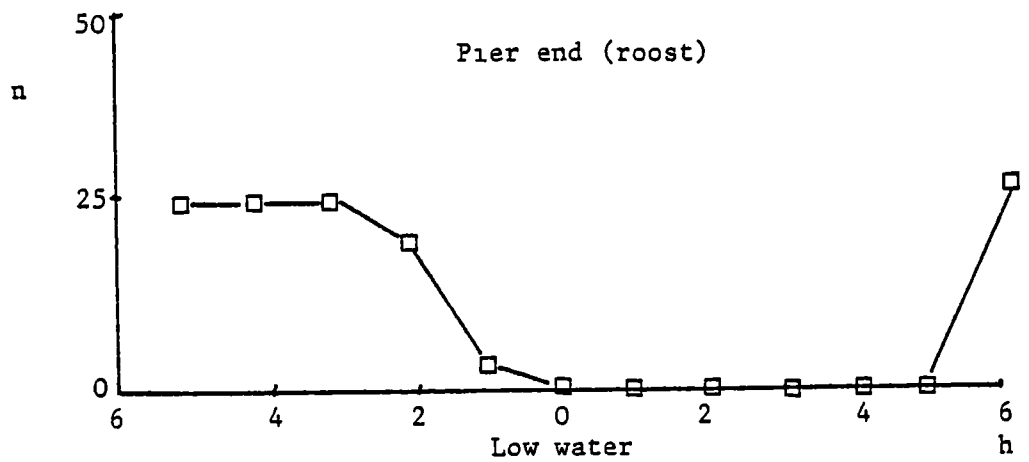
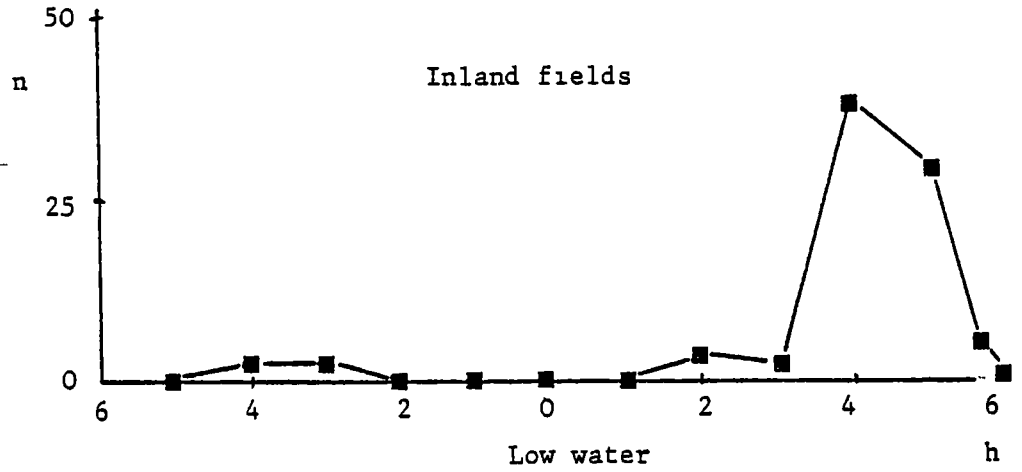
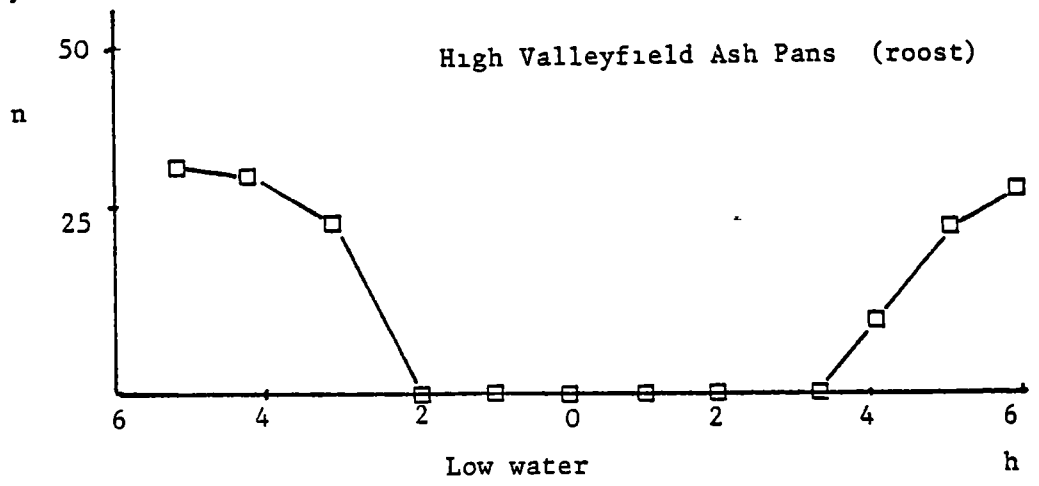

Fig 99

Oystercatcher

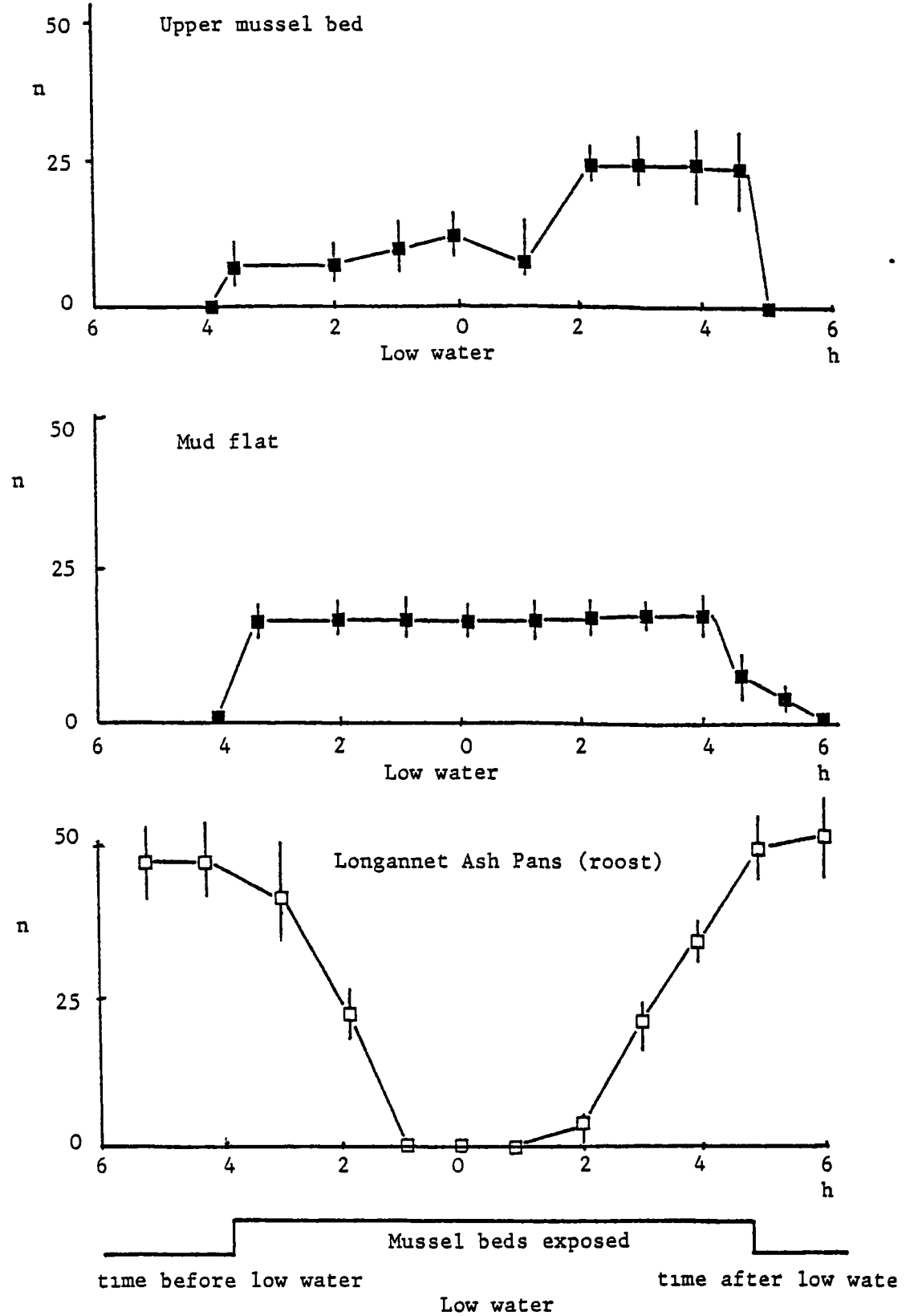

Fig 99 (contd) Numbers of Oystercatchers foraging (closed symbols) and roosting (open symbols) in seven areas of Culross Bay (Section 2 2), averaged across three spring tides in Early Winter (+ ranges) throughout the tidal cycle

As the tide receded the mudflats were exposed first and were occupied by the juveniles from LAPS and the pier end. The upper bed was exposed next and was occupied by the remaining pier end birds whilst the lower bed was exposed last and was occupied by birds flying directly from LAPS and more rarely HVAPS.

Chapter fourDISCUSSIONPART ONE - Parameters of the model(4 1) Prey density - Redshank(a) Hydrobia ulvae

Densities of Hydrobia were intermediate in the range of densities recorded on the Forth as a whole (McLusky et al. 1976) and elsewhere in the range of the species (Clay 1960a). Temporal variations in density (Fig. 12) show that recruitment at Culross occurred during the summer, as shown in previous studies on the Forth (Elliott 1979, Warnes 1981) and other estuaries (Rothschild 1940, Stopforth 1951, Green 1968 and Anderson 1971). At Skinflats (upper shore), recruitment started earlier in Spring, (Fig. 12), but was suspended over the Summer and resumed in Early Winter. This abnormal pattern probably occurred because the flat was exposed for long periods (up to 7 days, on neap tides), and during the Summer it dried out. In these conditions, Hydrobia spat, which are susceptible to desiccation (Stopforth 1951) probably suffered heavy mortality. In Spring and Early Winter cooler temperatures and low levels of incident radiation, meant the mudflat did not dry out on neap tides, and settling spat were recruited into the population.

Spatial distributions at both sites (Figs. 11 and 13) suggested the major factors influencing the distribution were salinity (as shown by Newell 1965, Muus 1967, and Wolff 1973) and tidal height (Wolff 1973, Elliott 1979, Warnes 1981,). The contrasting relationships between density and tidal height at the two sites suggest there is an optimum tidal height between 2 and 5 m above C.D (and therefore exposure) within

the littoral zone, favouring high levels of productivity in Hydrobia populations (loc. cit.)

(b) Corophium volutator

Densities of Corophium were at the lower end of the range quoted by Clay (1960b), 15 - 63,300 m⁻², but similar to the densities on the upper Forth recorded by McLusky et al. 1976. Densities varied greatly between relatively close plots in any one season, as on the Ythan (Goss Custard 1969). Seasonal trends across plots were generally consistent, hence the observed variability across plots was probably not a result of the supposed 'patchy' nature of Corophium distribution (Muus 1967).

Corophium has a salinity tolerance between 2 and 18‰ Cl⁻¹ (McLusky 1968). The virtual absence of Corophium from Culross, except at plots with significant fresh water inflow (section 2.2) may be explained by the high salinities at this site (25 - 32 ‰, Bowen Colthurst 1980).

Temporal fluctuations in Corophium density (Fig. 17) show the major recruitment occurred over the Summer, and continued into Early Winter, as occurs elsewhere in Britain (Watkin 1941, McLusky 1968, Mossman 1977) and in Denmark (Muus 1967).

(c) Macoma balthica

Densities of Macoma were in the lower half of the recorded range (52m⁻² - Cederwall (1977) to 16,000 m⁻² - Smit (1981)). Temporal fluctuations in the density of the smallest Macoma (Figs. 15 and 16) show the major spat settlement occurred between Autumn and Early Winter at both sites, later than spat settlement for Macoma recorded by Elliott (1979), Lammens (1967) and Warwick and Price (1975), but at a similar time to settlement recorded by Warnes (1981), and secondary maturation/spawning observed by Caddy (1967). Annual differences in the timing of spatfall in Macoma are considered normal (Ansell and Trevallion 1967). Densities of medium and large Macoma were relatively stable

temporally. Decreases in mid-winter probably reflected increases in the depth of burrowing in cold weather (Reading and McGroarty 1978, Warnes 1981, Penner 1981).

The greater populations of medium and large Macoma at Skinflats (upshore area) contrasted with previous studies which suggested populations are greatest in mid/low tide areas, with fine sediments (Beanland 1940, Newell 1965, Warwick and Price 1975, Tunnicliffe and Risk 1977, and Muus 1967). The data of this study were similar to the high densities of large Macoma at high tidal heights reported by Vassallo (1969). The differences between the sites in this study reflected differences in the firmness of the deeper levels of the substrate and therefore the maximum depth to which Macoma could burrow. A greater population of large and medium sized Macoma was found at Culross, which has soft sediments to greater depths, but these animals were beyond the range of both small sampling cores and foraging Redshank (pers. obs., Penner 1981).

Decreases in the population at low salinity plots are consistent with the salinity tolerance range of the species (20 - 34 ‰ - Warwick and Price 1975), whilst increases in the density with increases in tidal height were consistent with a mid-tide maximum in the population (Myren and Pella 1977, Beanland 1940).

(d) Polychaetes

Densities of polychaetes were slightly greater than on the polluted Tees estuary (Gray 1976) but at the lower end of the range quoted by Warnes (1981) ($10 - 17,000 \text{ m}^{-2}$), yet similar to other estimated densities on the Forth (McCraw in prep.). The distribution of species, with Nereis diversicolor at the upshore, upper estuary site (Skinflats), and Nephtys hombergii at the lower shore, lower estuary site (Culross), was consistent with the known salinity tolerances of the two species, 5 -

22% in Nereis (Wolff 1973) and 16 - 47% in Nephtys (Clark and Halderlie 1960, Duffes 1973).

Temporal variation in both species showed the major recruitment occurred over the summer in accord with previous studies in Nereis (McCraw in prep., Wolff 1971). The populations of larger worms were also generally greatest in Autumn and Spring and lower in the Winter, which probably reflects a tendency to burrow deeper during the colder months (Penner 1981).

(4.2) Prey Density - Oystercatcher

(a) Mytilus edulis

Bowen Colthurst (1980) has shown the greater density of mussels on the lower bed at Culross is a direct result of increased tidal inundation, which results in greater time available for feeding and hence a higher growth rate. Differences in percent coverage may be a result of substrate differences between the beds, the upper bed was mostly over rocks whilst the lower bed was over mud.

(4.3) Prey body mass

(a) Hydrobia ulvae

Temporal changes in AFDM (Fig 24) were inconsistent with the hypothesis that fluctuations in AFDM are mostly associated with reproduction (Chambers and Milne 1979). Large Hydrobia (> 2.5 mm) were heaviest in Autumn after they had bred. Decreases in the mass of large individuals between Autumn and Early Winter, at the same time that small Hydrobia were increasing in mass, suggests the decrease of the largest animals was not a result of failure to achieve an energy balance, but probably involved loss of gametic as well as somatic tissue. Continued decreases across all classes between Early and Late Winter is most likely

to represent emaciation as a result of low temperatures reducing activity and therefore feeding. Increases in AFDM between Late Winter and Spring probably involved increases in both gametic and somatic tissue as changes were relatively greater in the larger mature individuals. Warnes (1981) has shown egg production is most prolific at Skinflats in Spring.

Chambers and Milne (1979) found a similar decrease in the AFDM of large Hydrobia in Late Summer/Autumn, but this decrease did not continue throughout the Winter and Warnes (1981) found relatively stable AFDM in animals of 3 mm throughout the annual cycle, although larger individuals (4 mm) had greater AFDM in Spring.

Although the data in this study were collected through the severe winter of 1981/82, differences in emaciation did not appear related to the severity of conditions, as the data collected by Warnes (1981) were also from a severe winter (1976/77). In addition, the upshore site (Skinflats) might have been expected to suffer more in the cold weather, but AFDM did not vary between the sites in any season.

In combination with a decreased body mass, Hydrobia also had a greater ash content (Fig. 24) which lowered the assimilation efficiency of their predators (Fig. 33) in Late Winter. Differences in temporal variation of AFDM between studies (above) suggest this is unlikely to be generally true across estuaries, or even on the Forth in different seasons.

(b) Corophium volutator

Maximum AFDM occurred in Autumn when Corophium was probably reproducing (Fig. 26). Subsequent decrease in AFDM of adult (> 4 mm) animals, coupled with a simultaneous increase in the mass of smaller animals suggests this initial loss is at least partly gametic tissue, and not wholly emaciation. The decrease across all classes between Early and Late Winter probably represents emaciation during the more severe

weather conditions (section 3.18). In contrast, Chambers and Milne (1979) found no progressive decrease in AFDM of Corophium on the Ythan, but did find a similar summer peak.

The value of AFDM for medium sized animals (3 mm) was similar to a mean mass value quoted by Warnes (1981) from the same site at a lower tide level. The mass across all sizes was only approximately 60% of that recorded on the Ythan (Chambers and Milne 1979), but twice as large as the AFDM recorded for samples collected across several estuaries in S.W. England (Goss Custard 1977c). Considerable inter-estuary variability in the AFDM of Corophium is therefore apparent. The causes of this variability are unknown.

Percentage ash contents (% DAM) were similar to ash contents on the Ythan (Chambers and Milne 1979). Because DAM% was inversely related with AFDM, Corophium were not only lightest in Spring but also Redshank feeding on them had their lowest assimilation efficiency at this time. However, as with Hydrobia, differences in the temporal variation of AFDM between studies means this is unlikely to be generally true across estuaries.

(c) Macoma balthica

Temporal changes in AFDM were similar to changes reported by Chambers and Milne (1975b, 1979) and Beukema and de Bruin (1977) with a relatively constant AFDM throughout the Winter increasing to a maximum in Spring and Early Summer. Elliott (1979) also reported a maximum AFDM in Spring/Summer but a progressive decrease from Autumn to Late Winter.

Considerable spatial variability in the AFDM of standard size animals was found by Elliott (1979) whilst Hylleberg and Gallucci (1975) found the length/mass relationship in the closely related Macoma nastuta was nearly constant over a wide range of environmental conditions, in accord with the present study.

Lammens (1967), Ansell and Trevallion (1967) (in Tellina tenuis) and Elliott (1979) all found shell mass was relatively independent of season, in both small and large animals. Similar independence was found in the present study. Because shell masses constitute a large proportion of the total mass (Fig. 29) seasonal fluctuations in AFDM had little effect on the DAM%, consequently assimilation efficiency of Redshank feeding on Macoma remained relatively constant throughout the year at both Culross and Skinflats and this may be generally true across estuaries.

(d) Mytilus edulis

Bayne (1976) suggests the major factor influencing flesh mass in Mytilus is the food supply. Consequently, reductions in the time spent exposed at low tide which result in increases in the feeding time, lead to inverse relationships between flesh mass and tidal height (Baird 1966, Baird and Drinnan 1957, Wilson 1971, Seed 1973, Johnson 1981) and even differences in flesh mass between high and low points on the same mussel bed (Goss Custard pers. comm.).

Contrasting with these studies, differences in the mean AFDM of standard size mussels between upper and lower mussel beds (which had exposure times of 40 and 24% respectively, Bowen Colthurst (1980)) were not significant. Errors in the mean estimates of previous studies are generally not quoted and the significance of the differences cannot be assessed. Other studies have also shown no significance in the difference between tidal heights (Lent 1968, Bowen Colthurst 1980) or even the converse trend with tidal height (Rao 1953).

The depression of flesh mass in mussels around the centre of each bed (Fig 30) is probably a result of decreased salinity and reduced dissolved oxygen contents caused by sewage discharges. Both of these factors affect flesh mass locally (Baird 1966, Bayne 1976).

The relatively constant flesh AFDM over the Winter was similar to that reported by Chambers and Milne (1979), but contrasts with the emaciation throughout Winter recorded by Dare and Mercer (1975). Both studies also report increases in AFDM associated with reproduction in Spring which were not found at Culross. Goss Custard et al. (1981) found similar relatively constant AFDM throughout the year on the Exe. The causes of any particular relationship remain obscure. Flesh ash contents were similar to those reported elsewhere (Chambers and Milne 1979).

The recorded shell organic content (AFDM) was similar to that recorded by Price et al. 1977 - Total shell mass (= AFDM + DAM) was not significantly different for mussels of a given length across plots in contrast with previous studies which suggest a positive relationship between shell mass and tidal height (loc. cit.). As with flesh mass, however, the significance of differences in these earlier studies are generally not quoted.

The portions of mussel flesh left behind in mussel shells (stubs of the adductor muscle and edge of the mantle) were also the parts found to be most difficult to remove in the laboratory. Nevertheless, Oystercatchers are capable of removing these portions in captivity if offered only a few mussels (pers. obs.). This suggests these parts are normally excluded because handling them would be unprofitable (Sih 1980). No palatability effect was suspected.

(4.4) Biochemical and caloric contents

The inverse relationship between protein and carbohydrate content across all species/seasons was similar to that reported across seasons in the mussel (Dare and Edwards 1975), although in that study lipid content was independent of both protein and carbohydrate.

Changes in composition through the Winter, for bivalves, were not consistent with previous studies (Daniel 1921, Dare and Edwards 1967, Williams 1969, Ansell and Trevallion 1967) which suggest percentage carbohydrate content decreases, whilst percentage protein increases. This would suggest bivalves on the Forth were using both protein and lipid as energy reserves (as shown by Gabbott and Bayne 1973), despite high carbohydrate contents. Changes in the composition of Corophium and Hydrobia at Skinflats were consistent with the view that carbohydrates and lipids are utilized as an energy reserve before protein (loc cit.).

The estimated calorific contents were higher than previous published values from other estuaries for both Corophium and Nereis (Wood in Goss Custard 1977b, Chambers and Milne 1979), approximately equal for Mytilus (Dare and Mercer 1975) and lower for Macoma (Chambers and Milne 1979, Ansell and Trevallion 1977). The average energy content across all prey species and seasons was similar to other estimates for 'intertidal benthos' ($23.17 \text{ kJ.g AFDM}^{-1}$) (McLusky 1981, Crisp 1971). The very small changes in calorific contents throughout the Winter support the suggestion of Chambers and Milne (1979) that changes in calorific content of benthic invertebrates occur predominantly as a result of changes in reproductive condition. As changes in reproductive condition occur mostly in Spring and Summer (Elliott (1976), Chambers and Milne (1979), sections 4.1 a and b), the effect of changes in calorific value of prey on the energy intake of waders are probably insignificant in comparison with changes in other variables (see sections 3.6 and 4.6).

(4 5) Assimilation efficiencies of wading birds

Assimilation efficiencies (72 - 90%) were similar to previous estimates of assimilation efficiency in adult birds which feed on a wide range of both plant (seeds) and animal material (West and Hart 1966,

Willson and Harmeson 1973, Gibb 1957) but exceeded estimates for herbivores (32 - 41%) (Moss 1973, 1975, Ricklefs 1974).

Inorganic matter may influence the digestion of organic matter in two ways, either by mechanically obstructing the access of enzymes, or by increasing the gut pH and therefore decreasing the efficiency of protein digestion by pepsin, which is optimum in the range pH 1.5 - 2.5 (White, Handler and Smith 1964). This latter effect may be the more important because shells are crushed in the gizzard and mechanical obstruction seems unlikely, yet Fenchel (1972) also found assimilation in Hydrobia was dependent on the intake of inorganic particulate matter, and this invertebrate does not hydrolyze protein using the same endopeptidase.

The effect of inorganic matter on assimilation efficiency may explain some of the anomalies in the observed foraging behaviour of wading birds. Oystercatchers foraging on Macoma in the Wadden Sea (Hulsher 1980) and cockles (Cerastoderma edule L.) in Wales (Sutherland 1982) ingest only the flesh of these bivalves. They could probably ingest the whole prey (i.e. shell + flesh) faster and in doing so achieve a greater intake of energy (i.e. shell + flesh energy). The handling behaviour, therefore, appears inefficient. The effects of including the shell might reduce assimilation efficiency by between 10 and 15% which could make the ingestion of flesh alone more efficient (see section 4.3 (c)). Prey washing may also appear energetically inefficient but may perhaps be interpreted as the removal of inorganic matter (= mud) to improve assimilation efficiency.

(4 6) Relative importance of prey characteristics on the gross energy availability to wading birds throughout the Winter

In all the prey species (Hydrobia ulvae, Macoma balthica, Corophium volutator and Mytilus edulis) the major variable influencing changes in

the energy availability ($\text{kJ}\cdot\text{m}^{-2}$) was prey density. Although changes in the size specific mass were also important, this latter variable changed mostly temporally. Within a given season, therefore, prey density explained almost all the variability in energy availability. In addition, since temporal fluctuations in AFDM were relatively greater in this study than recorded elsewhere (section 4.1 (b)) the importance of size specific mass will be lower elsewhere. The importance of prey density on energy availability occurred despite an inverse relationship between mean size and density in three of the species. Changes in mean size were probably much less important because the populations of large individuals were relatively constant - e.g. in Macoma (Figs. 16 and 17). Increases in density therefore involved additional numbers of small individuals rather than replacement of the large by small animals.

As density was the most important factor influencing the availability of energy to wading birds, in those benthic invertebrates studied, wading birds would be expected to aggregate in areas where their major prey were most dense. Many studies have demonstrated the major factor influencing the density of estuarine predators is the density of their prey (Bryant 1979, Bryant and Leng 1975, Goss Custard 1970, 1977 a,b, Goss Custard et al. 1977, 1981, O'Connor and Brown 1977, Prater 1972, Sutherland 1982b, Warnes 1981, Wolff 1969, Zwarts 1976, Zwarts and Drent 1981). Relatively few situations have been described where prey density is not the major factor influencing predator distribution (Sutherland 1982b, Tjallingii 1971).

In general, the precise pattern of the estuarine predator response is also similar across species and sites with disproportionately more predators in areas of high prey density. This is presumably because individual animals attempt to maximize their own intake, but some subdominant individuals are excluded from the most preferred areas by

dominants, because of the deleterious effects large predator populations may have on their own food intake rate (Goss Custard 1976, 1980a, Zwarts 1978). Goss Custard et al. 1981 have shown young subdominant Oystercatchers are common on the most preferred mussel beds on the Exe estuary, in the Summer, but are excluded by more dominant adults in Winter, supporting the above hypothesis.

Disproportionately large numbers of predators in the high density areas are likely to inflict spatial density dependent mortality on the prey population (Hassell and May 1974). Density dependent mortality has been shown to occur in Corophium populations (Goss Custard 1977b). Such density dependent mortality may result in regulation of the prey population at levels below the carrying capacity of the environment (Southwood 1975). The results of the relatively few predator exclusion experiments, which have been performed within the estuarine habitat, however, do not support this hypothesis. For example, Petersen (1959) excluded avian predators from an estuarine mud flat, but few changes in the density of benthic invertebrates were recorded. In contrast a whole series of experiments, excluding a non-avian predator, the Starfish (Pisaster ochraceus), from rocky shores have demonstrated large increases in the density of their major prey (Mussels) Paine (1980). Whilst estuarine birds may inflict spatially density dependent mortality on their prey, the level of this predation appears generally insufficient to regulate the prey populations i.e. is undercompensating. The small proportion of benthic production which is consumed by avian predators (Warnes 1981, Goss Custard et al. 1980) supports the view that avian predation contributes little to the regulation of the level of benthic invertebrate populations.

In contrast with these data Evans et al. 1979 found waders removed almost 90% of the population of large Hydrobia on the Tees estuary in

Winter. The proportion removed however refers to only a restricted size class of the population and predation on the whole population is probably much lower.

(4.7) Prey availability

(a) Visual foraging Redshank

(1) Hydrobia ulvae

Temporal changes in numbers of Hydrobia on the surface were consistent with previous work relating surface numbers to environmental factors, both in the laboratory (Vader 1964) and field (Vader 1964, Little and Nix 1976), they all report increased burrowing with time since tidal exposure. Seasonal differences in behaviour (Vader 1964) were consistent with the effects of mud temperature (section 3.8.1).

Increased mud temperature may increase surface numbers by causing the animals to become more active. The increase in burrowing behaviour associated with increases in air temperature (section 3.8.1) may indicate the primary function of burrowing behaviour is to avoid desiccation as suggested by Barnes (1981). Desiccation may be an important factor in Hydrobia mortality (Stopforth 1951).

The increase in surface cues with increases in mud temperature and exposure was probably a result of the surface mud becoming less thixotropic as it dried out (Chapman 1949) and burrow structures consequently becoming more stable. A given quantity of burrowing behaviour would be more likely to leave a distinct cue as these factors increased.

Surface water content decreases with increasing time since tidal exposure (Fig. 37). The thixotropy/dilutancy boundary occurs after 2.25 - 2.5 hours (Chapman 1949) which approximately equals the time when burrows start to appear at this temperature giving support to the above

hypothesis.

The negative effects of density (Table 11) were unexpected. Possibly increased densities result in less particle flocculation by constantly mixing the mud and passing it through their digestive systems, and therefore contribute to mud instability, and increase the probability of burrow collapse.

(ii) Corophium volutator

Surface availability of Corophium was low in all conditions because the duration of emergence was short, whilst interemergence times were long (c. 1000x longer). Decreasing emergence with increases in both air temperature and time since tidal emersion may indicate a susceptibility to desiccation but probably reflects a decrease in the suitability of the surface substrate for feeding, as the time exposed is so short. Meadows and Reid (1966) observed that surface detritus drawn into the burrow on emergence is sieved using the setal basket and a current generated by the gnathopods. As surface water content decreases this filtering process is probably impeded.

Variability in the numbers of surface cues was similar to that observed in Hydrobia (above), which suggests the same factors, (e.g. mud water content) are important. It is significant that the percentage of the Corophium population available as a result of surface cues was almost four times greater than the proportion of Hydrobia in the same conditions. This suggests the burrows of Corophium are much more stable structures, probably a result of cementing secretions released from the second periopods (Hart 1930).

(iii) Macoma balthica

The activity of siphons was inversely related to air temperature and time since tidal emersion because the mudflat dried out as both these variables increased. Individual siphons remained active until all the

surface water in the immediate vicinity of the siphon burrow had gone. The large variability in siphon activity probably therefore reflects the variation in drainage/evaporation characters of the micro-climate around the siphon burrows. Whilst increased mud temperatures increased activity, increased air temperatures resulted in evaporation and indirectly decreased availability by a similar amount. As these variables were highly intercorrelated the net effect of temperature changes were negligible, compared to the effects of tidal exposure.

(iv) Nereis diversicolor

The increased activity of Nereis above the surface with increases in air temperature, is consistent with observations that activity within burrows also increases with increases in temperature in the laboratory (Penner 1981). Independence of emergence from changes in tidal exposure conflict with laboratory data which suggest Nereis burrow deeper as time since exposure increases (Penner 1981, Vader 1964). As the time between emergences is long, there is no clear reason why the depth to which Nereis retract in this time should be related with the frequency of emergence.

Nereis probably continued to feed throughout the period of exposure, whilst Corophium did not (above), because they ingested portions of detritus whole, via the extended pharynx (Clay 1960b, Trevor 1977, pers.obs.), and consequently were not so dependent on a high water content to handle the food efficiently. On the other hand, burrow depth is more probably related to with the probability of desiccation which increases throughout the exposed period (Fig 37).

(b) Prey availability - tactile foraging Redshank

Penner (1981) found 86-90% of Hydrobia in the top 2 cm. of substrate, at a different site within Culross bay (section 2.2) whilst only 60% were found in this study at Skinflats. If Hydrobia burrow to

avoid desiccation (Barnes 1981), the greater proportion below 2 cm. at Skinflats may reflect different drainage properties between the sites

Larger Macoma were found deeper in the mud by Greenhalgh (1975), Warnes (1981), Reading and McGrorty (1978) and Penner (1981). However, Chambers and Milne (1975b) and Hulscher (1980) both found small animals burrowed deeper in the Winter. The reasons for differences between sites remain obscure. Penner (1981) found 60-65% of Macoma within the surface 2 cm, whilst Reading and McGrorty found 70% in the surface 3 cm, in Winter, both of which compare closely with the 72% recorded in the surface 2 cm in this study. Most Corophium occurred in the top 4 cm of the substrate as found by Warnes (1981) and Mossman (1977).

Size distributions of Hydrobia and Corophium suggest animals of different size were randomly distributed with respect to depth. By selecting the surface portion therefore tactile foraging Redshank gained no advantage, nor suffered any disadvantage, because small or large Hydrobia and Corophium predominated in this region of the mud.

(4 8) Handling time

(a) Redshank

The time taken to handle 'small items' on the Forth was similar to the time taken to handle Corophium on the Ythan (Goss Custard 1977b). The close agreement between the observed handling time for medium Macoma, and that predicted from the depth distributions of both small and medium Macoma suggests medium Macoma took longer to handle than small Macoma because they were buried deeper in the mud. Macoma which were buried deeper in the mud probably took longer to handle because of the increased time required to extract them. Although large Macoma were buried even deeper in the mud, there was also a significant effect of size on the handling time. This was apparently because the width of large Macoma

shells (Appendix 1) exceeded the maximum gape of the Redshank, whilst the height and length did not. Redshank required several attempts before they got the prey in the correct orientation and could successfully swallow the item.

Although large Nereis generally burrow deeper than small Nereis (Muus 1967, Penner 1981) worms were invariably captured at the surface without probing. The relationship between handling time and body length (Table 13) was consequently a direct size effect. Worms on the Forth were handled almost twice as fast as worms of similar length on the Ythan (Goss Custard 1977a). The reason for such rapid handling is unknown. Conceivably fluid muds on the Forth may afford less grip for the parapodia and therefore extraction is faster (see Chapman 1949), yet handling times were not significantly different between Culross and Skinflats which refutes this hypothesis. Handling times were constant throughout the Winter, as found by Goss Custard (1977a) suggesting the birds did not become more proficient at handling with experience throughout the Winter (see also section 4.2).

(b) Oystercatcher

The increase in recognition time with mussel length suggests larger mussels were more difficult to identify than small mussels. These data conflict with the hypothesis that animals may develop 'search images' of prey (Tinbergen 1960, Dawkins 1971a,b), which enable them to efficiently identify profitable items, and thus reduce the time spent in recognition. In addition, small mussels which are closer to the boundary of the included items in the diet, might be expected to have longer recognition times, because the decision to include or reject the item is more difficult.

Hughes (1979) suggests an animal should only spend time acquiring information if the benefit of the information exceeds the detriment as a

result of the time spent acquiring it. Oystercatchers may derive benefits from choosing mussels within size classes which have certain characteristics which influence profitability, e.g. shell thickness (see section 4). The 6 to 8 seconds spent acquiring the information to distinguish these types would have a relatively small effect on the profitability of large mussels because the total handling time was relatively long (Fig. 45). In contrast, whilst distinguishing morphs of smaller prey would also be advantageous, the time spent acquiring the information (if it also equalled 6-8s.) would be a significant proportion of the total handling time (Fig. 45). The reduction in profitability as a result of spending time acquiring the information might therefore negate the advantage of identifying those items within the smaller size classes. The increase in recognition time with mussel length may therefore be interpreted as an increasing advantage of devoting time to acquiring information on morph types as mussel length increases.

In 'prizing' Oystercatchers, larger mussels took longer to manipulate (i.e. prize open) probably because these mussels had larger adductor muscles (section 3.19). In 'hammerers' large mussels took longer to smash open because they had thicker shells (section 3.19) (see also Goss Custard et al. 1981). The relatively greater increase in manipulation time in 'prizers', with increases in shell length, probably occurred because the relative increase in the size of the adductor muscle, between medium (30 mm) and large (70 mm) mussels (x15), was much greater than the relative increase in shell thickness (x3)

Although large mussels (70 mm) contained 10x more flesh than medium sized mussels (30 mm) they only required 1.9x longer to ingest because the bulk of mussel flesh in all sizes was extracted as a single mass and ingested whole.

Variability of all the components of handling time and total

handling time was large. Probably only a small part of this variability was a result of error in estimates of mussel size (Fig. 48). The major variability in handling time was explained by changes in the manipulation time (section 3.11). This suggests either large differences in the handling abilities of individual birds or structural differences between mussels of the same size were responsible for the observed variability. As the birds were not individually identifiable it was not possible to separate these effects. However, within observations on single individuals there were no obvious consistent trends. This suggests differences between mussels explain most of the variability in handling time, although the number of mussels observed in each 'individual' was small.

Norton-Griffiths (1967) showed immature Oystercatchers are less efficient at opening mussels than adults. Similar differences in foraging success with age have been reported for many bird species (Orians 1969, Recher and Recher 1969, Dunn 1972, Seancy 1978, Greig et al. 1983). In this study differences in age are unlikely to result in inter-individual differences as all the observed birds were 'adults' (section 2.1).

Reports of consistent differences in ability to handle prey, between individuals of the same age, are rare. Krebs et al. (1977) found highly significant differences in the abilities of individual Great tits when feeding on mealworms with pieces of tape attached, but these were unnatural prey. Goss Custard et al. (1981) report no significant differences in handling time between marked individual adult Oystercatchers which were resident on a mussel bed and those which were transient visitors to the bed, supporting the hypothesis that structural differences between mussels were the major factor influencing the variability in handling time within size classes.

(4.9) False recognitions, unsuccessful manipulations and kleptoparasitisms

(a) Redshank

The rates of unsuccessful pecks (3 13 1) were slightly lower than on the Ribble, in North West England (Greenhalgh 1975) and only between 5 and 20% of values recorded for Redshank on the Ythan (Goss Custard 1977b). Unsuccessful pecking was also less common than that recorded in Curlew Sandpipers (Calidris ferruginea) in South Africa (Puttick 1979). Since unsuccessful pecks increased throughout the tidal cycle, as the numbers of surface prey decreased and surface cues increased (section 3.7), unsuccessful pecks were probably directed at surface cues which appeared to contain prey but did not.

Although differences in pecking success of Curlew Sandpipers was independent of the time in the tidal cycle (Puttick 1979), differences in the rates of unsuccessful pecking between estuaries probably represent differences in the quality and number of surface cues. Bias across observers is doubted (Goss Custard 1977b).

Intraspecific kleptoparasitism was very rare (section 3.13.1). Three factors probably account for this. The absence of a social hierarchy amongst non-territorial Redshank means the gains of stealing in the long term would be equal to the losses to other birds for all individuals, hence there would be little selective advantage for kleptoparasitism. The profitability of a kleptoparasitized item is low because the time fighting over the item is long. The only recorded kleptoparasitism resulted in a chase and fight lasting 23 s. Thirdly, the handling times are so short the opportunity to kleptoparasitize seldom occurs. Interspecific kleptoparasitism was similarly rare probably because of this latter reason. Kleptoparasitism by Common gulls (Larus canus L.) (Hamilton and Nash 1928) was never observed

although these birds were frequently seen in the bay.

(b) Oystercatchers

Comparative values of false recognition, unsuccessful manipulation and kleptoparasitism are difficult to interpret because different studies adopt different methods of measurement, e.g. number of inter-bird attacks which successfully result in kleptoparasitism (Vines 1980) and kleptoparasitism per item 'found' (Goss Custard et al. 1981b). Kleptoparasitism was, however, probably at a similar rate to that recorded in the latter study and the source of the losses (Carrion Crows) was the same. Although birds may space themselves to avoid kleptoparasitism (Vines 1980) and hence the risk of kleptoparasitism has a large effect on the distribution of the birds (and therefore the mortality inflicted on the prey), the result of this spacing is the probability of sustaining a kleptoparasitic loss or achieving a gain is low.

In both Oystercatcher and Redshank inter- and intra-specific kleptoparasitism were uncommon events. Although different rates of kleptoparasitism for different prey types might occur, differences in rates of kleptoparasitism did not influence diet choice in these species. In other species, however, high and different rates of kleptoparasitism between alternative prey times have been shown to influence diet choice (Barnard and Stephens 1980).

(4 10) Metabolism - Redshank

(a) The inter-relationship of CO₂ production, O₂ consumption and heart rate over short periods in the laboratory

Most of the variability in respiratory quotient (RQ) occurred at the onset and cessation of activity. When birds became active the estimated CO₂ production increased rapidly whilst the estimated O₂ consumption

increased more slowly. RQ consequently rose. At the end of activity bouts the converse occurred. This effect can be accounted for by differences in response times of the gas analysers. Across a large number of observations the contrasting effects at the start and end of activities add a great deal of variability to the RQ estimates but do not bias the estimated mean. Although in a multiple regression the combined effects of temperature, time since placed into the apparatus, and body mass, explained only 3.5% of the variability in RQ, all the effects were biologically significant (and statistically, $p < .01$).

As none of the birds were starved prior to the respirometry experiments, values of RQ when the birds were first placed into the respirometer (0.9 - 1.0) suggest they initially metabolized stored carbohydrate and/or gut stored food (mostly protein and carbohydrate). Decreases in RQ with time suggests the birds gradually drew on fat and protein reserves as the carbohydrate and gut content was exhausted, until after approximately ten hours they were metabolizing mostly fat (heavy birds) or a mixture of fat and protein (light birds). Similar decreases in RQ from the time since feeding have been reported for Hummingbirds (Amazaila sp.) (Kruger et al 1980). Polar bears (Thalarctos sp.) also metabolize mostly fat after several hours fasting (Nelson 1973). Since the differences in the size corrected body mass reflect mainly the amount of fat stored, these results suggest that during relatively short fasts such as occur at high tide, fat birds (150 g) may avoid having to draw on protein reserves, whilst birds with little stored fat cannot. As most wading birds in Winter are relatively heavy (Minton 1975, Prater 1975, Smit and Wolf 1981, Branson 1975, Symonds 1980) and this excess mass is mostly fat (Davidson 1981), it is probable the amounts of protein used to supply energy demands will be small unless food becomes unavailable for long periods.

During brief periods of cold weather wading birds appear to draw mostly on fat reserves, whilst in long periods of severe weather both fat and protein are utilized (Davidson 1981, Evans and Smith 1975) supporting the hypothesis that protein is only used as an energy source during prolonged fasts.

The explained variability in metabolism by heart rate was much lower in this study than the variability explained in previous studies (Morhadt and Morhadt 1971, Butler et al. 1977, Lally et al. 1974, Ferns et al. 1979, Woakes and Butler 1983) which all have coefficients of variability in excess of 95%. In all these studies, however, the duration over which heart rate and metabolism were correlated was generally much longer (hours rather than seconds). Lund and Folk (1976) correlated the heart rate with metabolism in the Prairiedog (Cynomys ludovicianus) over 25 s periods. The generally poor inter-relationship between variables prompted them to adopt a smoothing technique by calculating a running average which takes information over a longer period. This 'improved the relationship' but the initial correlation coefficients are not quoted. In general, the shorter the duration the lower the variability in metabolism explained by heart rate measurements. Over the short periods used in this study the explained variability was great enough to allow prediction of the metabolism in the field but only by including temperature as a second independent variable. Where temperature is excluded the variability in the relationship may place a practical limit on the period over which heart rate can be used to estimate metabolism in the field. The constancy of the regression coefficients with changes in duration was not investigated. Applying a metabolism against heart rate relationship obtained over long periods to the prediction of metabolism over short periods will certainly underestimate the error in the prediction and could be systematically biased

Because temperature entered the predictive equation relating metabolism and heart rate as a significant predictor variable the gradient of the relationship between heart rate and metabolism, within temperatures, must be different from the relationship across temperatures. At constant temperature, an increase of metabolism by 1 J.s^{-1} as a result of increases in activity required an increase in the heart rate of 5.5 Hz, whereas across temperatures, an equal increase in metabolism as a result of decreased temperature required an increase in heart rate of only 3.4 Hz.

As the energy and therefore oxygen requirements for these changes are equal, the lower tachycardia in response to temperature may be accompanied by an increased stroke volume or $\text{Ca}_{02} - \text{Cv}_{02}$ difference (Ficks equation). The heart rate response of pigeons (Columba livia) to increased energy requirements in exercise (Butler et al. 1977) also appears greater than the response to energy demand as a result of changes in temperature (Bouverot et al. 1976). In this case change in the $\text{Ca}_{02} - \text{Cv}_{02}$ difference was also different, but stroke volume was not measured. Segrem and Hart (1967) found heart rates were higher at a given oxygen consumption in Peromyscus exposed to cold than in the same animals when exercising.

Differences in physiological response to decreasing temperature and increasing activity have important consequences for the application of heart rate metabolism relationships to the prediction of energy expenditure in the field. Estimates of metabolism which are interpolated from a relationship between heart rate and metabolism derived from increases in metabolism as a result of changes in temperature, may overestimate the metabolism associated with changes in activity at constant temperature. In the case of the Redshank, this overestimate would be approximately 60%. Flynn and Gesseman (1979)

found estimates of daily energy expenditure (i.e. variations at relatively constant temperatures) from a heart rate metabolism relationship at different temperatures was on average 30% greater than a simultaneous estimate from food consumption in the Pigeon. This discrepancy is possibly accounted for by the use of a heart-rate metabolism relationship based on the thermoregulatory response alone.

(b) Individual differences

Individual differences in the relationship between heart rate and metabolism have been reported elsewhere for both mammals (Morhardt and Morhardt 1971, Lally et al. 1974, Lund and Folk 1976) and birds (Ferns et al. 1979, Butler and Woakes 1979). Because body mass was an important factor in a multiple regression analysis when data from all the individuals was included (Table 18), and because individuals varied in mass throughout each run as well as between the two runs included in each regression, changes in body mass explain at least part of the individual differences found in this and possibly other studies. Body mass differences did not explain individual differences found by Ferns et al. (1979), demonstrating that other factors, for example differences in the oxygen capacity of the blood, must also be important in individual differences.

(c) Effects of observer handling

The prolonged tachycardia both during attachment of transmitters and upon release into the aviary, were probably a stress response, and may not have a metabolic correlate (Ursin et al. 1979). Even if metabolic levels are elevated during this period estimates of metabolism inferred from heart rates will be spuriously high if taken within a certain time from release, in this case 20 minutes. Twenty minutes was also the time taken for metabolism to decrease to a steady level in a respirometer, in both Redshank (this study) and Scrub and Stellar's Jays (Mann 1983), and

may possibly be generally applicable.

(d) Variation in heart rate during short duration activity

Changes in heart rate throughout short duration bouts of activity at first suggest the energy demand for walking exceeds the supply of oxygen. During this initial stage the birds probably hydrolyse stored muscle ATP to meet the current energy requirements, (Piper 1980) and subsequently replenish the store by resynthesizing the ATP when activity ends. The short duration of the lag means anaerobic provision of the deficit (e.g. by glycolysis) is improbable.

Because active animals may be supplying part of their energy requirement by hydrolysis of stored ATP (and possibly glycolysis in longer bouts) and resting animals may have elevated energy requirements to replenish such stores or remove the anaerobic end products (e.g. lactic acid), estimates of mean heart rates recorded throughout spontaneous bouts of activity which are normally short, will probably underestimate the costs of a given activity. Estimates of resting costs from the adjacent resting periods will be overestimated. This possibly explains why the difference between foraging and resting costs estimated from heart rates in the Blue Winged Teal (Owen 1969) was not significant.

Animals behaving naturally seldom reach steady state energy expenditures for most behaviours (except for example during flight and prolonged rest) and this presents a problem for the prediction of the energy cost of these behaviours using the heart rate technique. The peak energy expenditure between the onset of a behaviour, and a period after the behaviour (approximately equal to the duration of the behaviour) is probably the most practical estimate of energy expenditure when this technique is used to estimate the costs of short duration behaviours.

(e) Resting metabolism

The close correspondence between estimates of resting metabolism using the heart rate technique and estimates from indirect calorimetry largely confirms the heart rate technique as a valid tool for estimating free-living energy expenditure. Estimated resting metabolism at the lower critical temperature as a multiple of the predicted BMR (Lasiewiski and Dawson 1967, Aschoff and Pohl 1971, Kendeigh 1970) equalled $1.59 \times$ BMR in adults, which was greater than the mean of seventeen estimates for temperate birds and mammals ($\bar{x} = 1.405$) (Table 42) but within the range (maximum = 1.7) and not significantly different from the mean ($z = 1.6$, $p > 0.05$). Redshank do not therefore appear to have an unusually high resting metabolic rate as has been suggested might be the case (Davidson 1981).

Observed characteristics of the resting metabolism versus temperature relationships of adult and juvenile Redshank, and the expected values from allometric equations relating those characteristics with body mass in non-passerine birds are presented in Table 43 (Ashoff 1981, Lasiewiski and Dawson 1967, Calder and King 1974, Shilov 1968).

Juvenile Redshank appeared to conform to the Newtonian model of heat loss in a homeotherm (Scholander et al. 1950, Pearson 1950). They maintained their energy expenditure at a basal level above the critical lower temperature, probably by increasing the insulation properties of the plumage. Below the lower critical temperature, increases in heat output were matched by increased thermogenesis. The gradient of the metabolism against temperature line below T_{1c} extrapolated to the expected body temperature of a non-passerine bird (41°C) (Shilov 1968, Calder and King 1974).

In contrast adults had a wider thermoneutral zone extending down to 16° suggesting they have plumage with a greater insulative capacity. Below T_{1c} , however, the conductance was greater than expected for a non

Table 42

Estimates of the resting metabolism of eighteen birds and mammals as a multiple of Basal metabolism (predicted for animals of equal mass from allometric equations)

Birds

| Species | body mass | RMR/BMR | Source |
|------------------------|-----------|---------|--|
| Hummingbird | 10 g | 1.68 | Wolf and Hainsworth (1971) |
| Long billed marsh wren | 12 g | 1.3 | Kale (1966) In King (1974) |
| Quail | 42 g | 1.28 | Fedak <u>et al.</u> (1974) |
| Bobwhite quail | 190 g | 1.25 | " |
| Partridge | 490 g | 1.62 | " |
| Guinea Fowl | 1.2 kg | 1.61 | " |
| Turkey | 4.8 kg | 1.24 | " |
| Goose | 3.8 kg | 1.34 | " |
| Rhea | 22 kg | 1.72 | Taylor <u>et al.</u> (1971) |
| Rhea | 22 kg | 1.45 | Crawford and Lasiewiski (1971) in Fedak <u>et al.</u> (1974) |

Mammals

| | | | |
|-----------------|--------|------|-----------------------------|
| Mouse | 21 g | 1.55 | Taylor <u>et al.</u> (1970) |
| Kangaroo rat | 41 g | 1.21 | " |
| " | 100 g | 1.14 | " |
| Ground squirrel | 235 g | 1.39 | " |
| White rat | 380 g | 1.43 | " |
| Dog | 2.6 kg | 1.38 | " |
| Dog | 18 kg | 1.16 | " |
| | | 1.4 | |
| | | 0.18 | |
| | | 17 | |

passerine bird of 150 g (Aschoff 1981) and the intercept on the temperature axis (31°C for the indirect calorimetry data, 35°C for the heart rate data) falls well below the expected body temperature. Similar data have been found in Scrub jays (Mann 1983) and Mallards (Anas platyrhynchos) (Smith and Price 1973). It is unlikely that Redshank allow their body temperature to fall as low as 31°C whilst still remaining active, which implies that they are unable to maintain maximum insulation at temperatures below T_{1c} . The curvilinear nature of the relationship below T_{1c} , in both adult and juveniles, supports the hypothesis of a gradual reduction in insulation below this temperature. Inability to sustain insulation at low temperatures may have important consequences for the daily energy requirement of adult Redshank.

(f) Walking metabolism

The close correspondence between predicted walking metabolism at a speed of $0\text{m}\cdot\text{s}^{-1}$ and resting metabolism (RMR), in the aviary and laboratory data, was unexpected. Previous studies in both birds (Fedak et al. 1974, Taylor et al. 1971, Brackenbury and Avery 1980) and mammals (Margarita et al. 1963, Cerreteilli et al. 1964, Taylor et al. 1971, Taylor et al. 1974, Taylor 1977, Taylor and Rowntree 1973) suggest the predicted metabolism at a walking speed of $0\text{m}\cdot\text{s}^{-1}$ exceeds 'resting' metabolism. In most of these studies the stationary comparison is BMR. Predicted metabolism when walking at $0\text{m}\cdot\text{s}^{-1}$ averages only 1.06 x observed RMR (in birds) ($n = 7$, $\sigma = 0.17$, Fedak et al. 1974). Observed differences between predicted metabolism at $0\text{m}\cdot\text{s}^{-1}$ and resting metabolism, with both the heart rate and indirect calorimetry techniques, were not significantly different from this mean ($z = 0.35$, $p > 0.05$).

As it is frequently suggested, the difference between predicted metabolism when walking at $0\text{m}\cdot\text{s}^{-1}$ and observed 'resting' metabolisms,

the 'fixed cost' of locomotion, is a result of potential energy fluctuations of the whole animal (Margaria et al. 1963, Fenn 1930, Schmidt Nielsen 1972) these costs must be mostly covered by interconversion of potential and kinetic energy during acceleration/deceleration (Clark and McNiel Alexander 1975) or potential and elastic energy in the limbs (Cavagna et al. 1963).

Increases in the fixed cost of locomotion as temperature fell below T_{1c} suggests there is a disruption of insulation by walking. Comparison of the conductance values of these relationships suggests insulation was reduced by approximately 29%. As movement will both disturb the boundary layer and increase forced convection, this effect does not necessarily imply a reduction in the insulative properties of the plumage.

The independence of the walking speed against metabolism relationship from changes in temperature suggests the decrease in insulation with walking is not progressive. The coefficient of the relationship ($= 0.382 \text{ J.m}^{-1}$) was approximately 1/5th the value obtained by indirect calorimetry in juveniles and 1/8th the expected value for a non-passerine bird of 150 g (Fedak et al. 1974). Comparison of either the indirect calorimetry or biotelemetry estimate with the allometric prediction suggests Redshank are highly efficient at walking - this is probably in part a consequence of the Redshank's long legs, which may be regarded therefore as an adaptation to efficient low cost walking, in addition to wading.

The difference between observed estimates in the aviary and laboratory were probably partly a result of stress elevating the estimates in the respirometer. Walks in the treadmill were forced walks of relatively long duration (c. 12 minutes) and especially at high speeds the birds showed considerable amounts of non-walking behaviours which

Table 43

Characteristics of the thermoregulatory responses of Juvenile and Adult Redshank compared with the predicted values from allometric equations for non-passerine birds of equal mass

| Characteristic | Juvenile (95 g) | | Adult (150 g) | |
|--|-----------------|-----------|---------------|-----------|
| | Observed | Predicted | Observed | Predicted |
| T_{lc} °C | 21 | 20 | 16 | 18 |
| C^b J.°C ⁻¹ s ⁻¹ | 0.057 | 0.06 | 0.0919 | 0.075 |
| T_B^c °C | 41 | 41 | 31 - 35 | 41 |

a T_{lc} - Lower critical temperature predicted from Lasiewiski and Dawson 1967.

b C - Conductance (equals gradient of metabolism versus temperature relation below T_{lc}) predicted from Ashcoff 1981

c T_B - Body temperature.
Observed equals intercept of the metabolism versus temperature relationship on the temperature axis.
Predicted from Shilov 1968, Calder and King 1974.

were associated with elevated metabolism. In addition, because estimates using heart rate were for walks of much shorter duration, the estimates may not be directly comparable.

(g) Non-walking activity metabolism

The similarity in estimates of energy expenditure whilst pecking, probing and tactile searching was surprising considering the apparent differences in effort which appear to be expended on each behaviour. Energy Expenditure during these behaviours were all less than 2.0x BMR (at T_{1c}) which suggests they are relatively inexpensive compared with the cost of flight (12.0x BMR) (Tucker 1968, 1972, Wolf and Hainsworth 1971, Hails 1979) and swimming on the water surface (4.0x BMR) (Prange and Schmidt Nielsen 1970, Woakes and Butler 1983). Foraging costs were similar to the costs of feeding in the Black Duck (Anas rubripes) [1.8x BMR] which were also estimated using the heart rate technique (Wooley and Owen 1978) and 'non-flight activity' in the Phainopelpe (Phainopelpe nitens) [1.54x BMR] (Walsberg 1978) estimated by indirect calorimetry. The costs are also similar to 'light sedentary work' and 'standing activities' in Humans (Homo sapiens) (Passmore and Durnin 1955).

Because estimates of the costs of these behaviours in other species are few, many authors have resorted to guessing the costs (from the effort which appears to be expended in each behaviour) to convert time budgets into energy budgets and hence estimate daily energy expenditures. Estimated costs of handling activities bore little relationship to the apparent effort expected and consequently such guesses may often be in error. Guesses of foraging costs for non-flying foragers vary between 2.0x BMR (Kushlan 1977) and 5.0x BMR (Holmes et al 1979) (see Table 44) and average 2.64x BMR (n=10). If the estimated costs in Redshank are representative, they suggest such guesses are on average 40% and up to 263% too great. As foraging is a

Table 44

Estimates (guesses) of energy expenditure whilst foraging, for non-flying foragers, as a multiple of BMR, from studies where the cost has been used to convert time to energy budgets in birds.

| Source | | Species | Estimated energy expenditure (x BMR) |
|-----------------------|------|---|--------------------------------------|
| Kushlan | 1977 | Ibis | 2.0 x |
| Custer and Pitelka | 1972 | Lapland longspur | 2.1 x |
| Ettlinger and King | 1980 | Flycatcher (sit and wait) | 2.1 x |
| Maxon and Oring | 1980 | Spotted sandpiper | 2.4 x |
| Schartz and Zimmerman | 1971 | Dickcissel | 2.4 x |
| Dwyer | 1975 | Gadwall | 2.5 x |
| Pettifor | 1983 | Kestrel (sit and wait) | 2.5 x |
| Tarbotton | 1978 | Black shouldered hawk (sit and wait) | 2.5 x |
| Wakely | 1978 | Ferruginous hawk (sit and wait) | 3.5 x |
| Holmes <u>et al.</u> | 1979 | Red eyed vireo Black throated Blue warbler | 5.0 x |
| | | Mean | 2.64 x |
| | | | 0.93 |

Sit and wait = Estimate whilst sit and wait foraging.

large component of most avian time budgets (Austin 1978, Davies 1977, Ettinger and King 1980, Gibb 1959, Orians 1961, Puttick 1979, Schartz and Zimmerman 1971, Turner 1981, Verbeek 1964, Wakely 1978b, Weins and Innis 1978), daily energy expenditure estimates will be highly sensitive to such errors (Ettinger and King 1980).

(h) The costs associated with carrying a fat store

Across individuals there was a positive relationship between metabolism and body mass during all activities (Table 19). As differences in body mass reflected mostly differences in stored fat, these data show there is a metabolic disadvantage of carrying a fat store.

The regression coefficients of metabolism on mass varied between activities (Table 19). The greatest coefficient was that whilst walking. This probably reflects the increased cost of acceleration and deceleration with increases in mass (Clark and McNeil Alexander 1975). The coefficient when probing was greater than when at rest, whilst the coefficient when pecking was lower than when at rest. The reasons for these differences are unknown.

The positive coefficients of metabolism on body mass suggest there is no metabolic advantage of maintaining a fat store because of the enhanced insulation resulting from the fat layer. These data conflict with observations of domestic mammals, which suggest fat is a good insulator (Irving 1956a,b) with between 11 and 17% of the insulative properties of still air (Monteith 1973). Analysis of the locations of fat deposits in wading birds offers some indication of why this might be the case. Fat is deposited primarily in the interclavicular pit and abdominal regions. Since the majority of heat production probably occurs in the pectoral region, the fat is poorly sited to act as an insulator. Redshank (and other birds) probably avoid depositing fat over the pectoral muscles because its insulative properties restrict heat

flow from the flight muscles during flight and may result in overheating.

The cost of carrying a fat store varies with the amount of fat stored and the activity budget of the animal. In Winter, Redshank carry a fat store which amounts to approximately 11% of the body mass (Davidson and Evans, 1981). The lean mass (without fat) approximately equals 139 g, whilst the total mass (with fat) approximately equals 156 g. Accurate activity budgets for Redshank are unknown, because of the problems of assessing nocturnal activity. Fig. 100 shows the time it is calculated a Redshank must forage to achieve a positive energy balance in Early and Late Winter, at Skinflats. If it is assumed Redshank forage for this required time and roost/rest/preen for the remaining time, and it is also assumed the coefficient of metabolism on mass whilst foraging equals $0.0168 \text{ J.g}^{-1}\text{s}^{-1}$ (that whilst walking) and in the remaining time equals $0.098 \text{ J.g}^{-1}\text{s}^{-1}$ (that whilst resting), the costs of carrying the fat store can be assessed.

At 0°C the costs of carrying fat equals $18.2 \text{ kJ. day}^{-1}$, whilst the total daily energy requirement equals approximately 288 kJ. day^{-1} . The cost of maintaining the fat store at 0°C therefore equals only 6 to 7% of the total daily energy requirement. As there is no insulation advantage in carrying a fat store and a cost of carrying the store, Redshank, and probably other waders, carry fat stores in Winter, mainly as an insurance against severe weather conditions, during which they cannot meet a 24 h energy balance (see below). The size of the store is probably regulated at a level which balances the metabolic advantage of carrying extra fat with the probability not achieving an energy balance, since conditions would have to be very prolonged and severe (less than -4°C) to reduce the store directly by failure to meet a 24 h energy balance.

Observations of changes in body mass of waders during and after

severe weather support the hypothesis that the reduction of body mass after mid-winter is a result of regulation, and not a direct reduction because of failure to meet a 24 h energy balance (Pienkowski et al. 1979, Dugan et al. 1981).

(4.11) Metabolism - Oystercatcher

The variation of resting metabolism with temperature suggests Oystercatchers conform to the Scholander model of heat flow. The lower critical temperature was 7°C lower than that expected for a non-passerine bird of 500 g. (Lasiewiski and Dawson 1967). Thermal conductance below T_{1c} was also lower than expected and the intercept on the temperature axis of the metabolism against temperature relationship below T_{1c} equalled the expected body temperature (=41°C). Metabolism at thermoneutrality equalled 1.25x the mean predicted BMR for a non-passerine bird of 500 g. (Aschoff and Pohl 1970, Lasiewiski and Dawson 1967, Kendeigh 1970). In combination all these factors suggest Oystercatchers have a high insulative capacity compared with other non-passerines of similar size.

The linear relationship between windspeed and metabolism was unexpected as previous work has demonstrated non-linear relationships, increments at high wind speeds having a relatively lesser effect than increments at low speed (Gessamen 1973, Robinson et al. 1976, Cnappell 1980). Presumably the inferred non linear relationships are a result of disruption of the boundary layer which occurs at low speeds (Kersten 1982). Possibly the continued increase in metabolism with increases in windspeed in this study reflects disruption of the plumage insulation after removal of the boundary layer. These data conflict with previous work in Oystercatchers (Whitlock 1978) in which a non-linear model was fitted, but a linear model was not explicitly rejected. More recently

Goldstein (1983) has re-examined the literature (loc cit) and concludes in most cases a linear model fits the data as well as, or better than, the curvilinear model, in accord with the present study.

PART TWO - Tests of model predictions and general discussion

(4.12) Search strategy

(a) Relationship between pacing rate, stride length and walking speed

Redshank and Oystercatcher increased their walking speed by increasing both the pacing rate and stride length. When walking slowly both species always made short strides, unlike Quail (Coturnix sp.) which make both long and short strides at slow speeds and become obligate long striders at fast speeds (Clark and McNeil Alexander 1975).

As stride length varies systematically with walking speed, attempts to estimate walking speeds by multiplying the observed pacing rate by the mean stride length (e.g. Goss Custard 1977a) will underestimate speeds at high pacing rates and overestimate speeds at low pacing rates. Thus estimates of walking speed from the regression equations on one hand and the pacing rate multiplied by mean stride length on the other, differed by more than 20%, above 3 paces s^{-1} and below 1 pace s^{-1} .

(b) Comparison of predicted and observed search speed

In both Oystercatcher and Redshank the similarity between observed and predicted walking speeds from the acceleration limited model (section 1.2) suggests velocities are acceleration limited above 2 encounters. m walked⁻¹. Slower velocities than predicted may have occurred at lower encounter rates for several reasons. These are detailed below.

The time to reach maximum velocity (T_{ac}) may have been overestimated. A lower value of T_{ac} would result in a steeper decline

of velocity from v_{\max} at encounter rate equals zero, and bring predicted and observed velocities below 2 encounters m^{-1} closer, but would also alter the value of $Da_1 \text{CRIT}(1)$ (section 1.2) and the nature of the prediction above 2 encounters m^{-1} walked. Further, this does not explain the difference in velocity between foraging and non foraging birds (section 3.17).

Alternatively, at high velocities p_d (the probability of detecting an item) may become inversely related to velocity. Where the decrease in p_d has a more deleterious effect on energy returns than the increase in the velocity the predator should not continue to increase velocity to v_{\max} but forage at a slower speed, as suggested by Gendron et al. (1983).

An inverse relationship between p_d and velocity may occur because searching a given area to some constant level requires a fixed time. At low velocities the potential area than can be searched is wider than the maximum distance the animal can reach (foraging path width). As velocity increases a decrease in the area searched only occurs outside the foraging path width and therefore the encounter rate continues to rise. At a critical velocity the boundary of the searched area falls within the foraging path width and may therefore decrease encounter rates.

A second mechanism may cause reduction in detection increases in potential energy fluctuations as velocity increases (Margarita et al. 1963). Clark and McNiel Alexander (1975) have suggested the head bobbing behaviour of Quail may be an adaptation to keep the head stationary for the maximum period in each stride to facilitate prey detection. As velocity increases the percentage time the head is stationary decreases, and probably therefore detection decreases also.

In Redshank increases in predator velocity with time since tidal emersion were probably mediated by changes in mud softness resulting from

decreases in mud water content (Fig. 37). The inverse relationship between velocity and mud softness was probably a result of two factors. Firstly a decrease in the ability to accelerate because the force transmitted to the mud is not matched by an equal ground reaction, and secondly a decrease in v_{\max} . Velocities at given encounter rates did not differ between plots in the Oystercatcher, probably because the mussel beds were all firm and therefore the consequences of mud softness were not found.

The similar relationship between predator velocity and encounter rate, for different prey types (Table 24), conflicts with observations of Goss Custard (1977b) who found Redshank walk faster when feeding on Corophium than on Nereis. This latter result conflicts with the current study more than is immediately apparent, because encounter rates with Nereis in Goss Custard's study were lower than with Corophium. Goss Custard (1977b) suggests this may be because detecting worms is more difficult, and this is analogous to observations that Thrushes (Turdus sp.) also search more slowly when feeding on inconspicuous prey (Smith 1974). Possibly observed differences in the searching velocity of Redshank (loc cit.) were a result of differences in mud softness between the sites at which Nereis and Corophium were respectively common. Mossman (1977) showed Corophium prefer sediments with a high silt fraction whilst on the Forth Nereis was most common at a site with a high clay content which is also extremely soft (McCraw, pers. comm.). Differences in sediment preferences between the species may therefore support the hypothesis that differences in the observed walking speeds at Nereis and Corophium sites may be a result of differences in mud softness.

Velocity was independent of temperature in both species in contrast to the positive relationship between walking speed and temperature in the Bar-tailed Godwit (Smith 1975). These latter data have been quoted as

supportive evidence for a progressive decrease in predator velocity as prey availability (in this instance Arenicola marina) decreases (Evans 1976, Krebs 1978). This conflicts with the predictions of the above model (section 1.2). Whilst the encounter rate with Arenicola declined with decreases in temperature the birds expanded their diet to include the polychaete Scoloplos armiger and hence total prey encounter rates increased. The decrease in velocity may thus be accounted for by the acceleration limited model (section 1.2) and these data do not conflict with this model's predictions.

The inverse relationship between predator velocity and prey encounter rate has several important consequences for predator-prey relationships.

Predators walking slower in high prey density areas will spend more time in these areas and populations of predators will therefore tend to accumulate (orthokinesis). This is one mechanism by which density dependent mortality may be inflicted by predators on a prey population, without the predators requiring knowledge of the overall prey distributions (see also section 4.12.e).

Holling (1959) suggested that at high densities of prey, ingestion rates will be limited by handling time (the functional response). More recently Krebs et al. (1983) have shown the asymptote of functional response curves lies well below that predicted by handling time limitations alone. Part of the difference between predicted and observed asymptotes may be explained by changes in diet with increases in density. The inverse relationship between predator velocity and prey encounter rate may explain the remaining discrepancy. As the asymptote of predator ingestion generally occurs at low densities in waders (Goss Custard 1977a,b, Sutherland 1982b) and other animals (Chant and Turnbull 1966, Cook and Cockrell 1978, Hardman and Turnbull 1974, Holling 1965,

Mook and Davies 1967, Sandness and McMurty 1970), density dependent mortality is less likely to be influenced by the functional response than the aggregative numerical response (Hassel and May 1974)

(c) Changes in foraging mode

The superiority of tactile searching in Redshank (section 3.17.2) was a result of a wider feeding path (section 3.9) and a greater proportion of prey available (section 3.7) hence, although encounters with Nereis were zero with this method, this was more than offset by the greater encounter rates with lower profitability prey. The advantage of tactile foraging increased with increases in time since tidal emersion, and decreases in temperature, since availability of prey to visual feeders decreased with these changes whilst availability to tactile feeders did not.

Contrary to the predictions of the model, Redshank fed visually over 90% of the time at both sites (section 3.17.2(b)). It is thought the major constraint on tactile foraging was firmness of the substrate. At Skinflats which has a compact mud surface, tactile foraging only once exceeded 10% in the population, when storm water presumably softened the surface sufficiently for the birds to insert their bills. The decrease in the proportion of birds foraging in the tactile mode with increases in time since tidal emersion (Fig. 63) is also consistent with this hypothesis, as at tidal emersion high water content would reduce the resistance of surface layers but as they dried out the mud would become more dilutant (Chapman 1949). Surface firmness has also been shown to have important effects on the foraging distributions of Avocets (Recurvirostra avosetta) (Tjallingii 1971) and Shelduck (Tadorna tadorna) (Warneş 1981, Evans and Pienkowski 1982) both of which feed by moving their bills through the surface sediments in a manner similar to tactile foraging Redshank.

The effects of substrate firmness may be assessed in the model by varying the depth to which tactile foragers can probe the bill. By reducing the depth from 2 cm to 1 cm tactile gains become reduced by between 10 and 15% which makes visual foraging more profitable above about 10°C and between 0 and 2 hours after tidal emersion. Precise relationships between the percentage of prey present in depths less than 1 cm are unknown. At the point where mud is so firm that tactile foragers could only take prey at the surface, gains by visual foraging exceed tactile gains in all conditions, because tactile foragers would derive no advantage from surface cues.

A range of conditions exist, from those where the mud is very soft and tactile foraging is the most efficient method in all conditions, to those where the mud is firm and visual foraging is always more efficient. Between these limits the most effective mode is influenced by the effects of temperature and tidal cycle on mud firmness and prey availability. Increasing mud temperatures favour the visual mode. Over the initial period of tidal exposure, tactile foraging may become less favoured as the mud dries out and becomes firmer, but then more favoured because of decreases in prey availability to visual foragers.

Observations at sites where the mud is fluid at a site within Culross Bay but outside the study area, suggest tactile foraging is the dominant mode throughout the tidal cycle (also Evans 1979). At other sites Redshank switch to tactile foraging at low temperatures (Goss Custard 1969, Warnes 1981) and with increases in time since tidal emersion (Warnes 1981). These data support the hypothesis that changes in mud firmness are a major factor influencing the foraging mode of the Redshank. Further evidence comes from some observations at Culross where birds were observed alternating between modes as they encountered small patches of surface water c. 2 m wide where presumably mud solidity

was reduced and tactile foraging became more profitable.

(d) Foraging versus not foraging

The temperature below which it was predicted to be unprofitable to continue foraging (-30°C) was 2°C lower than the minimum recorded temperature on mainland Britain since the 1920's (-28°C , Bracknell Met. Office). Whilst birds were not observed to discontinue foraging under severe conditions (-7°C), these data cannot be used to support the model since they do not differ from the predictions of the null hypothesis. As Redshank continued foraging at this temperature, the conditions under which it becomes unprofitable to feed must be even more severe and consequently such behaviour will be encountered only infrequently. Evans (1976) cites two cases of waders discontinuing foraging in severe conditions but no exact weather conditions are detailed.

Redshank may have stopped foraging in high winds ($> 10\text{m.s}^{-1}$) but at much milder temperatures than predicted (Fig. 65), because high winds reduced prey availability, but more probably because it reduced foraging efficiency directly, by buffetting. The effect of buffetting might be to reduce p_d (the probability of a predator detecting a prey). Reductions in p_d could reduce the effective prey availability (equation 12) below $D_{a1}\text{CRIT}$, and therefore make it profitable to stop foraging. A second alternative is that there are other risks associated with foraging in high wind, which also influences fitness, such as being blown over into the mud. More research is required to separate between these alternative explanations.

When Redshank were noted to stop foraging, in the presence of an avian predator, they concealed themselves in runnels and at the edge of the sea-washed turf. In these cases the decision of whether to forage or not was probably influenced by a trade-off with other risks associated

with foraging. Redshank exposed on the open mud surface are probably more likely to be captured by a raptor than those hiding in runnels etc, where they are less likely to be detected and aerial manoeuvres are probably impeded. Avoidance of predation in the field has also been shown to affect the foraging decisions made by Blue gill Sunfish (Lepomis macrochirus) Mittlebach 1981, and House sparrows (Passer domesticus) Grubb and Greenwald 1982.

Although the prediction that animals should stop foraging below a critical availability is of theoretical interest, in wading birds the conditions in which all local habitats fall below $D_{ai,CRIT}$ is very infrequent, and as a tactic in the field therefore the behaviour is probably also very rare. In other habitats, however, the decrease in food availability in severe weather may be sufficient to make non-foraging a more frequently profitable tactic. For example, ground feeding birds may stop foraging when food availability is reduced by snow cover (Spencer 1981).

It should be emphasised that prolonged conditions below $D_{ai,CRIT}$ are not the ultimate cause of cold weather movements, in birds, as implied by Spencer (1981), or seasonal migration between habitats in birds and winter hibernation in mammals as suggested by Avery (1983). Since the net energy gain at which it becomes profitable to stop foraging is always negative (section 1.2), animals may encounter conditions frequently, in which it is profitable to continue foraging, but in which they still fail to achieve a positive energy balance. If these conditions are prolonged the animals may exhaust stored energy reserves and die. It is this risk of mortality, associated with the probability of achieving a positive energy balance, which is the ultimate factor influencing cold weather movements and possibly seasonal migration/hibernation, and not prolonged conditions below $D_{ai,CRIT}$.

(e) Angularity in the search path

Observed changes in search path angularity with availability at the same scale as patch width, support the model's predictions that Redshank respond to availability using a klinokinesis. In contrast, the prediction of klinotaxis was not upheld. Redshank therefore appear to choose patches on the small scale using two very simple methods (klimo- and ortho-kinesis).

(f) Spatiotemporal exploitation patterns

In both Redshank and Oystercatcher the majority of birds fed in the area which provided the greatest returns of net energy (and protein). In Redshank the most profitable area was behind the tide edge (Fig. 63 and 64) and most birds fed at the lowest exposed area (Fig. 98). In Oystercatcher the most profitable area was the lower mussel bed (section 4.13) and most birds fed on this bed (Fig. 99).

Whilst most birds adopted the strategy of feeding in the best area, all birds did not. The advantage of or reason for not feeding in the most profitable area for food gain is unknown. It is possible that the dominant members of the population excluded subdominants because of the deleterious effects large populations of predators may have on their own energy gain rates (Goss Custard 1977a,b, 1980a, Zwarts 1978, Vines 1980).

(4.13) Diet Choice(a) Profitability and the effects of including costs on diet choice predictions

The major factor influencing gross energy profitability, P_{gi} (eqn. 36) (and Gross protein profitability) was prey size, because size had a large influence on the variability of both energy content (E_{t1}) and handling time (T_{t1})

Redshank prey were relatively small, when compared with the predator dry mass (95 - 100 g). Prey mass divided by predator mass varied between 10^{-5} (small Hydrobia) and 10^{-2} (large Macoma). All the prey were handled rapidly (90% of handling times were less than 5 seconds), and false recognitions and unsuccessful manipulations were infrequent. Gross energy profitability of the larger Redshank prey was generally high (150 J.s^{-1} handling)

Oystercatcher prey were relatively large Dry prey mass divided by dry predator mass varied between 10^{-3} and 0.14. These prey were handled slowly and much time was spent attacking or probing prey which ultimately provided no energy return. Profitabilities of the largest (most profitable mussels) were only between 1/5 and 1/3 of the profitability of large worms to Redshank. The profitability of large cockles to Oystercatchers (c $21 - 25 \text{ J.s}^{-1}$ handling - calculated from Sutherland 1982c, assuming an energy content of 21.4 kJ.g^{-1} AFDM - Chambers and Milne 1979) is lower than that of large mussels (this study - Fig. 86) The estimate of handling time in Sutherland (1982c) does not include time spent in unsuccessful handling attempts and consequently the profitability of cockles is an overestimate.

The effects of including costs on profitability (equation 6) was dependent on the size of the gross profitability and the scale of the costs Costs increased with increases in predator size. In Redshank, which are small birds feeding on high profitability prey, the effects of including costs on the profitability of the larger (high profitability) prey were negligible (section 3.18.1). The effect of including costs on the profitability of smaller (low profitability) prey was much greater. In Oystercatcher, which are larger and feed on low profitability prey, the effect of including costs on profitability was greater and even in the most profitable prey including costs reduced the gross profitability

by over 10%. Comparative data for homeotherms are few. Turner (1982) found the net profitability of large flies (Scatophagia) to Swallows (Hirundo rustica) was over 90% of the gross profitability, which compares closely with the data for the highest profitability prey in this study. The effects of including costs on the profitability of the prey of several bird species were estimated (Table 4§) assuming prey handling costs to equal 1.9x BMR (section 3.15, Table 22). BMR was estimated from Aschoff and Pohl (1971) in the α phase.

In all the above cases including the costs of handling prey reduced the gross profitability by less than 25%, suggesting the data from this study are generally applicable. Different effects of costs on profitability, in different predators, lead to different effects of including costs on the predicted diet. In a species like Redshank, where costs are insignificant in high ranking prey, net energy gains (E_{net}) when including the most profitable items will be similar to gross gains, unless those prey are scarce when the costs of searching may significantly influence E_{net} . Since including costs has a greater effect on smaller, low profitability items, these items are less likely to be included in the diet, when E_{net} is not reduced by including search costs. In these species the predicted most preferred items are unlikely to change when costs are included, but the predicted diet might be expected to become narrower (as found in Redshank).

In a species like the Oystercatcher where costs are significant in the most profitable prey, including costs may change the ranking of profitabilities, since differences in costs between prey are also likely to be more significant. Net energy gains (E_{net}) when including the highest profitability prey will also be reduced in these species when costs are taken into account. As the profitability of smaller prey will also be reduced by including costs, these effects may cancel and the

Table 45

Estimates of net energy profitability as a proportion of gross profitability calculated from gross energy profitabilities published in quoted papers assuming the costs of prey handling equal $1.9 \times \text{BMR}$ (section 3.15) (BMR predicted for predator of equal mass after Aschoff and Pohl 1971).

| Source | Prey | Predator | J.s^{-1} | | ϵ_h | P_1/P_{g1} |
|--|--------------------------------------|---|-------------------|-------------------|--------------|--------------|
| | | | P_{g1} | J.s^{-1} | | |
| Krebs et al. (1977) | Mealworm (<u>Tenebrio</u>) | Great Tit (<u>Parus major</u>) | 144.5 | 0.61 | 0.99 | |
| Goss Custard (1977) | <u>Nereis</u> | Redshank (<u>Tringa totanus</u>) | 280.1 | 1.9 | 0.993 | |
| Turner (1982) | <u>Scatophagia</u> | Swallow (<u>Hirunda rustica</u>) | 15.3 | 1.07* | 0.93 | |
| Sutherland (1982) | Cockle (<u>Cardium edule</u>) | Oystercatcher (<u>Haematopus ostralegus</u>) | 22.5 | 5.0 | 0.77 | |
| Inferred from Goss Custard et al. 1981 a and b | Mussels (<u>Mytilus edulis</u>) | Oystercatcher (<u>Haematopus ostralegus</u>) | 45.6 | 5.0 | 0.891 | |
| Pulliam (1980) | Seeds | Chipping sparrow | 24.0 | 0.6 | 0.97 | |
| Davies (1977) | <u>Scatophagia</u> | Pied Wagtail (<u>Motacilla alba</u>) | 355.5 | 0.6 | 0.99 | |

ϵ_h = estimated handling costs

* author's own estimate

predicted diet remain unaffected. The factor most likely to influence diet is the costs of searching. As the high profitability prey become more scarce, E_{net} when including only the high profitability items will decrease, and the lower profitability prey will have a greater probability of entering the diet. The predicted diet would therefore broaden.

The contrasting effects of changes in the relative size and availability of high profitability items, on the profitability rankings and predicted diet width when costs are included in the predictions are summarized in Table 46. Since the relative size and availability of prey are unlikely to be intercorrelated, including costs may modify the predicted diet, of almost any predator. It is not possible therefore to assess whether studies which have excluded costs e.g. Krebs et al. 1977, Goss Custard 1977a, but still found support for the model predictions did so because costs were unimportant (i.e. the effects of relative size and availability of high profitability items on the significance of costs cancelled each other), or because costs were important, but the predators were insensitive to them. Similarly, in tests which exclude costs, but find no support for the gross maximization predictions (e.g. Goss Custard 1977b, Giraldeau and Kramer 1982), the animals may deviate because they do not optimize either gross or net energy gain in the diet, or because costs are indeed important.

The importance therefore of measuring energy expenditures, along with other model parameters, cannot be overstressed. Without these measurements the importance of NET energy maximization on foraging behaviour cannot adequately be assessed. Cowie (1977), investigating the behaviour of Great tits in mealworm prey patches, found the birds left patches later than predicted by a gross energy maximization model. Including costs in the prediction improved the fit between observed and

Table 46

The effects of including costs on diet predictions. Important variables are located in boxes. The effects of changes in these variables in the directions indicated, on the influence including costs has on diet predictions are listed

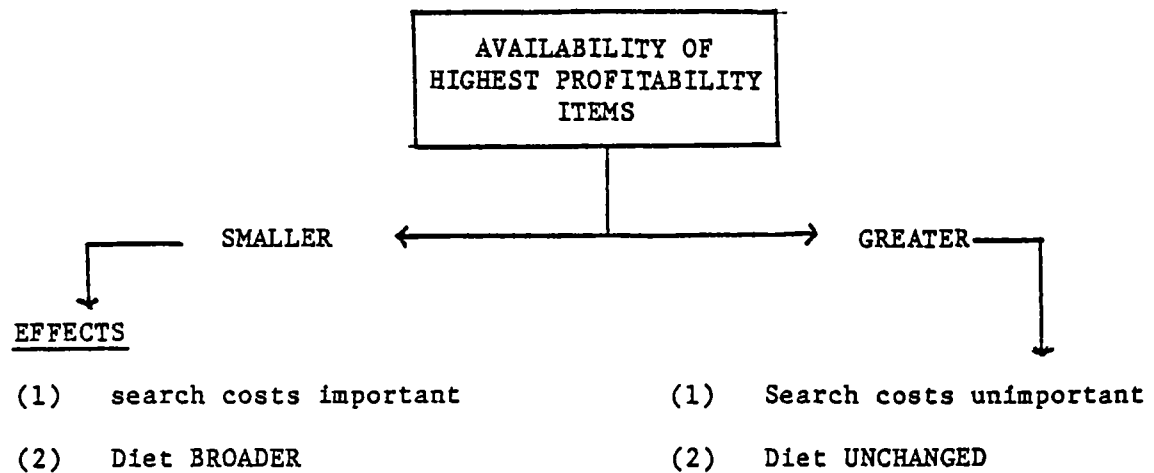
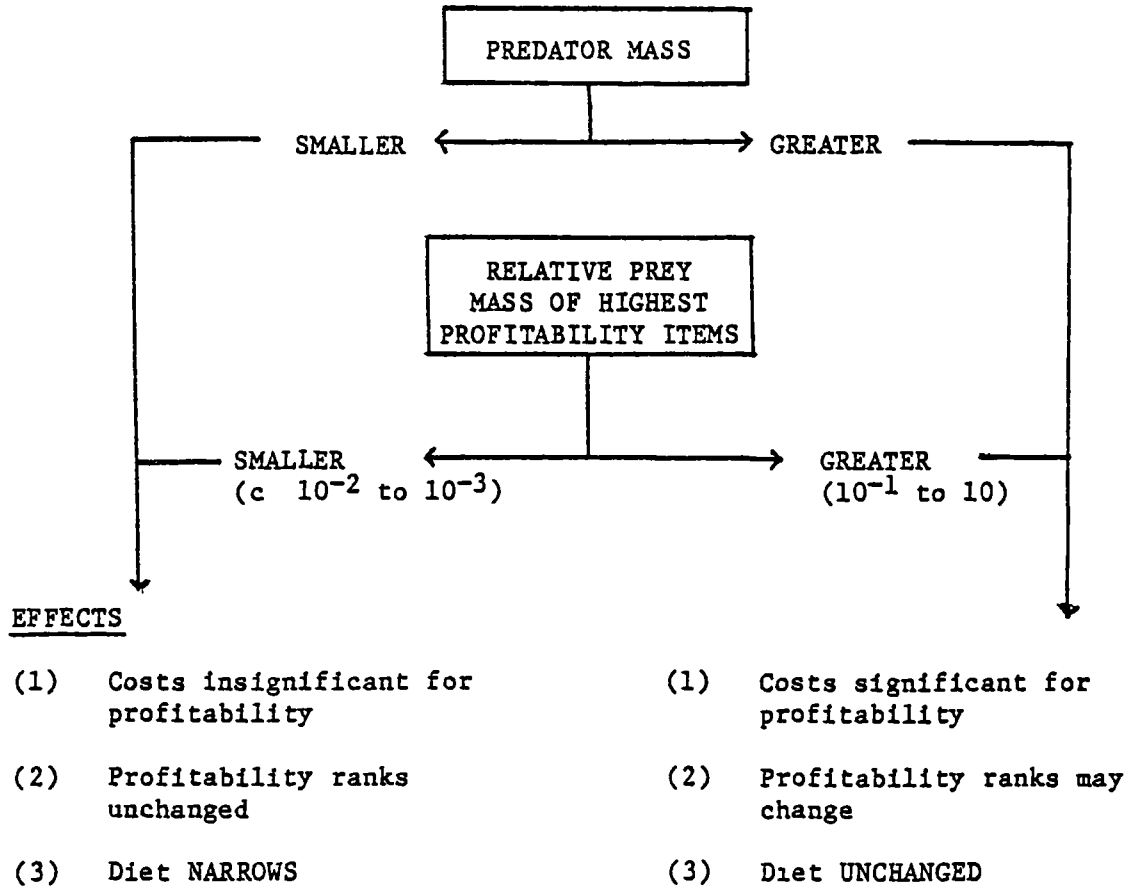

predicted, demonstrating the importance of including costs in model predictions.

(b) Temporal changes in profitability

Temporal changes in profitability have been shown to be large, and affect prey types differently, with consequent temporal changes in the rank of some profitabilities, in the Redshank (section 3.18.2). Temporal changes may occur over long periods, as a result of seasonal changes in body condition, or over the short term, mostly as a result of changes in unsuccessful attack rates. Changes in handling time were not important.

Where predators feed on a variety of prey types these rank changes are likely to be the rule, rather than the exception, because changes in energy content, and unsuccessful attack rates, are probably only weakly correlated in time between prey species. Temporal changes in profitability ranks would have important implications if they were correlated with changes in availability. For example, as Redshank prey Macoma become less available the rate of unsuccessful pecking increases, which results in a decrease in profitability. Positive intercorrelations of this type might form the basis of prey switching (Murdoch and Oaten 1975) in which the predator 'switches' its most preferred item to that which it encounters most frequently. Negative intercorrelations on the other hand might lead to counter-switching (Visser 1981) - in which the predator switches between the least frequently encountered items.

Previous explanations of 'switching' behaviour have mostly suggested a causative effect of encounter rate. For example, increases in the frequency with which a predator encounters prey results in a progressive decrease in either the recognition time (due to formation of a search image - Dawkins 1971a,b) or manipulation times as a result of learning

(Hughes 1979). These changes result in an increase in profitability of more frequently encountered items and therefore to a switching in preference between items which temporally become frequent. A similar causative explanation of counter-switching is that as the density of a given prey increases it may derive benefits from conspecifics which reduce its profitability to a predator. For example, attack success of Goshawks (Accipiter gentilis) on woodpigeons decreases with increases in pigeon flock size (Kenward 1978).

It is probable, however, that most predators in the field will be selected to handle prey as efficiently as possible. Changes in the encounter rate with items inside the optimal set are unlikely to result in progressive learning. Relatively constant handling times throughout the Winter in both Oystercatcher and Redshank, despite the opportunity to learn and hence improve performance support the hypothesis that progressive improvement of handling times in the field are unlikely to explain switching in anything but young animals. A possible alternative explanation for switching (and counterswitching), is that non-causative correlations between profitability and availability result in changes of the rank order of profitability and therefore changes in the preferred diet in relation to availability.

(c) Comparison of observed and predicted diet choice

(i) Redshank

The diet predictions of the maximization of net energy gain model provided an inadequate description of the diet choice behaviour of the Redshank, for two reasons. Firstly, Redshank included some prey in the diet which it was predicted they should exclude (and excluded some prey it was predicted they should include). Secondly, outside of the predicted and observed inclusion points, items were occasionally selected

when the model predicted these items should be totally rejected (= partial preference).

Differences between the observed diet and the diet predicted by the maximization of net energy gain model are detailed as follows. In all seasons Redshank were observed to ingest more large worms than it was predicted they should include in the diet, and since prey are either predicted to be included or excluded from the diet this also meant they selected more large worms than were predicted to be available. The smallest worms on the other hand were under selected (i.e. fewer were ingested than predicted) in all seasons except Spring.

The most probable explanation for these discrepancies is error in the estimate of availability. Small worms were rarely noted to emerge in feeding behaviour above the surface (section 3.8). Since the measured time above the surface was presumed to be equally distributed across the worms present a bias in activity towards larger worms would result in an underestimate of their availability of small worms.

Alternatively, large worms which are mobile and expose a relatively large area above the surface may be more conspicuous than Hydrobia, but small worms less conspicuous. Since effective path width is probably dependent on conspicuousness (p_d), but was calculated for Hydrobia only (section 3.9), effective path width may have been overestimated for small, but underestimated for large worms. This would also result in underselection and overselection of small and large worms respectively. Whilst these explanations probably explain the observed differences in Autumn, Early and Late Winter, in Spring the observed selection of worms greatly exceeded the predicted numbers available in all classes (Table 32). This was possibly because Spring is the season in which Nereis spawn (Dales 1950). Spawning in Nereis is fatal (Clay 1960b). Linke (1939) observed that post spawning many adult worms were found on the mud

surface, either dead or with ruptured body cavities. The high intakes of worms in Spring may involve similar moribund or dead adults, which would not be predicted to be available from the availability estimates (section 3.8).

A further discrepancy in the diet predictions was that in Autumn and Early Winter, Redshank appeared to exclude medium sized Macoma, whilst the model predicted these items should be included. Since the predicted and observed intakes in Late Winter and March were well matched, this does not appear to be a result of errors in the estimate of availability of these prey. The most probable cause of this error was that numbers of Macoma were not equally distributed throughout the size class. Since profitability varied within each size class (Fig. 70), if the distribution of Macoma within the size class was not even, the profitability of those prey would differ from the estimated mean profitability of the class. This was certainly the case after spatfall in Autumn when most Macoma in the medium size class were at the lower boundary of the class. In addition to the profitability of these items being lower than the mean for the whole class, the probability of misidentifying these items as small Macoma was greater than for items at the class centre (Fig. 46). It was not possible to subdivide the classes since these were defined by the ability to distinguish the sizes by direct observations (section 3.12)

In all seasons the intake of small items was lower than predicted by the models. A comparison of the size distribution of Corophium selected by Redshank (in pellets), with those in the environment, in Autumn and Early Winter, revealed that in fact the number of size classes of Corophium included in the diet was GREATER than the distribution predicted by the net energy maximization model (Fig. 82). The majority of small items were either Corophium or Hydrobia (small Macoma were

relatively infrequent). This suggests the number of classes of Hydrobia included was less than predicted, and as Hydrobia was the more abundant item, in combination selection of Hydrobia and Corophium resulted in an overall underselection of 'small items', although no data on size selection in Hydrobia were available from these seasons to test this hypothesis. In Spring, comparison of the selected size distribution of Corophium with that in the environment showed the number of classes included in the diet was narrower than the prediction (Fig. 82). In addition, the selected distribution of Hydrobia in Spring, inferred from collections around search paths was narrower than the net energy maximization hypothesis (Fig. 81).

In Spring, the number of classes of Hydrobia and Corophium included in the diet was probably less than predicted by the net energy maximization model, because the availability of large worms was underestimated (above). Since large worms were the most profitable prey (Fig. 84) it would be expected ^{that} an increase in the availability of these prey would result in a lower probability of small (low profitability) prey entering the predicted diet. Percentage selection of small items was shown to be inversely related with the observed intake of large worms, in support of this hypothesis. Across all plots, conditions, and prey types, the net energy gain model provided the best fit of the alternate hypotheses in Spring, and explained 56.9% of the variability in numbers of items of each prey type observed ingested. These data suggest Redshank do maximize the net rate of energy gain when foraging in Spring. Discrepancies between the predicted diet and that observed were mostly a result of inaccuracies in the estimate of availability of high profitability prey (large worms)

In other seasons, the inclusion of more Corophium size classes than predicted by the net energy maximization model, whilst underselecting

'small items' as a whole, at most sites, was consistent with the predictions of the protein maximization model. This model predicted a wider inclusion of Corophium, which contain more protein (Table 7), but a narrower inclusion of Hydrobia, which are poor in protein (Table 7). In each of these seasons protein maximization predictions explained more of the variability in numbers of prey items which were observed to be ingested than any other model. These data suggest the cause of the discrepancies between the observed diet choice in Autumn, Early and Late Winter, and the predictions of the net energy maximization model, was a result of most birds foraging to maximize protein intake rather than to maximize the rate of net energy gain.

Why Redshank maximize protein intake throughout the winter remains a problem. Observations in Late Winter on the Forth were made after a period of severe weather when both fat and protein stores were probably depleted (Davidson 1982). After such conditions Redshank may replace protein before fat (and hence forage to maximize protein intake), because low protein stores may render them more susceptible to avian predation which can be significant in wintering shorebirds (Page and Whitacre 1975). Nevertheless, both Autumn and Early Winter observations were made in mild weather, with no preceding harsh weather, and replacement of lost protein cannot easily explain the observed protein maximization at these times, since birds are unlikely to need to draw on protein reserves during normal high water roosts (section 4.10(a)).

A second hypothesis is that if reduction in the assimilation efficiency with increasing intake of inorganic matter is a result of reduction in gut pH (because of the high Ca^{++} content of the shells) - see section 4.5, and therefore a reduction in the efficiency of pepsin action, a disproportionate quantity of the undigested material would be protein. Hence although assimilation averaged 70 - 90%, assimilation of

protein might be considerably lower. In the absence of information concerning the daily essential amino acid requirements of Redshank, the abundance of these amino acids in the diet, and protein assimilation efficiency, this problem is likely to remain unsolved.

Using the current data, it is possible to assess the importance of maximizing energy intake for foraging Redshank, by constructing a daily energy budget and assessing the proportion of available time Redshank would be required to feed to achieve a positive energy balance.

Figures 63 and 64 show the theoretical maximum net energy gains for Redshank foraging at both Skinflats and Culcross, across a range of temperatures and tidal exposure times, in Early Winter. As Redshank underselect (i.e. ingest fewer than predicted) small items and medium Macoma, which constitute the majority of the ingested energy, these estimates are approximately 2x too large. Similar theoretical maximum energy gains, modified for differences between predicted and observed intakes, were calculated for Late Winter. Redshank were able to and most appeared to remain in the most recently exposed areas throughout the ebb tide (Fig 98), where energy gains were greatest. On flow tides the time since tidal exposure for all areas of the flat became progressively longer, and energy returns decreased.

Although in theory Redshank were able to forage whenever the mudflats were exposed, in practise they did not because environmental conditions (mostly wind) reduced their ability to forage and/or because they had to perform other activities, e.g. vigilance and flight to escape predators, which are incompatible with foraging. Time budgets of 'foraging' Redshank (Table 47) show the time spent in these competing activities was small, as has been found in other time budgets constructed for Curlew sandpipers (Puttick 1979) and Grey Plovers (Pluvialis squalator) (A Wood, pers.comm.) on the Tees. When a predator was

Table 47

Time budgets of 'foraging' Redshank.

| Behaviour | Time observed (s) | % Time observed |
|------------|----------------------|-----------------|
| Foraging | 10,078.8 | 99.16 |
| Vigilance | - | - |
| Flight | 36.7 | 0.36 |
| Preening | - | - |
| Aggression | 48 5 | 0.47 |
| Calling | - | - |
| TOTAL | 10,164.0 | 100.0 |

present, Redshank spent longer periods in flight. For example between 1140h. and 1240h. on the 18.3 81, Redshank foraging at Skinflats were disturbed repeatedly by a female Sparrowhawk (Accipiter nisus). During this 60 min. period almost all foraging birds were observed to fly in tight flocks, from the open flat into runnels and to the junction of the sea-washed turf and mudflat. The majority of birds were in flight for approximately 8-10 minutes. Predator attacks were rare in the study areas. During ninety hours of field observations in Late Winter (1982), only six birds of prey were sighted (2 Kestrel (Falco tinnunculus), 3 Sparrowhawks, and 1 Peregrine falcon (Falco peregrinus). These birds caused significant disturbance on only two occasions. This would suggest Redshank spend approximately 4-5 minutes in predator avoidance flight each day.

Non-foraging activities include flight, preening, and washing. Apart from disturbance by predators (above), Redshank at Skinflats and Culross fly between the roost and feeding sites. At both sites the round trip distance equalled 4 to 5 km. Redshank were timed flying over a standard distance at Culross, both into and out of the roost.

The major variable influencing the flight speed was the wind velocity. Birds flew slower with headwinds and faster with tailwinds, and possibly adjusted the flight speed so that power input was optimized (Tucker 1972). In the absence of any data concerning the relationship between energy expenditure and flight speed in the Redshank this hypothesis could not be tested. There was also a significant effect of flock size on flight speed. Birds in flocks flew faster. Redshank flying in flocks probably experienced mutual sheltering and increased flight efficiency (Lissaman and Schollenberger 1970). The advantage of a tailwind when flying in one direction was normally offset by the disadvantage of a headwind when returning. On average, the travel

between roost and feeding site occurred at a flight speed of 10.1 m.s^{-1} (mean of 43 flight speed estimates at 0 m.s^{-1} windspeed). The time to cover 4.5 km. at this speed equals 7.4 min. At the maximum flight speed observed, this time was reduced to 4.5 minutes, whilst at the slowest speed observed, the time increased to 12.8 minutes. In combination with the disturbance by predators and flights on the mudflats (above), Redshank spent between 11 and 21 minutes in flight per day. A figure of 16 min. has been included in this budget.

Redshank spent less than 0.1% of the 'foraging' time preening (Table 47) and similarly birds on the mudflat which were 'not foraging' spent the majority of time resting or roosting, but not preening. Although no time budget data were collected from these birds, preening probably did not account for more than 5% of the 'non-foraging' time on the mudflat. Most washing behaviour occurred as the tide reached the top of the mudflats on flow tides, and was followed by preening before the birds roosted. Estimates of the time spent preening and washing as the tide reached the top of the mudflat were made on three Spring tides in Late Winter. On all three tides, washing and preening were never observed in more than 40% of the population at any one time. Redshank were estimated to spend between 15 and 25 minutes washing and preening at this time and a figure of 20 minutes has been included in this budget.

The energy cost of preening and washing was assumed to equal that of foraging. Estimates of the energy cost of preening by radio-telemetry suggest it is of similar cost to 'foraging', but washing could not be costed as water shorted the batteries of the transmitter. Wooley and Owen (1978) also found preening to cost the same as foraging in the Black Duck, but washing was more costly (2.9x BMR). Roosting (with one leg retracted and the beak placed in the scapulae) was common in the radio-telemetry study aviary (section 2.17). Nevertheless, only three

uninterrupted roosts longer than 15 minutes were recorded, all at 8 to 9°C. Initially, roosting energy expenditure exceeded resting costs but declined until after ten minutes roosting was significantly less costly than resting (\bar{x} roost cost = 2.12 J.s⁻¹, \bar{x} rest = 2.21 J.s⁻¹, $t = 9.88$, $p < .001$). The energy saving 0.09 J.s⁻¹ was assumed to be constant across temperatures. Increasing windspeed had two effects on the energy budget, it increased energy expenditure (section 3.15) in both the foraging and non-foraging periods, and increased the time Redshank were prevented from foraging. Possible thermoregulatory benefits of mutual wind sheltering and absorption of incident radiation were ignored.

Whilst foraging the birds had a positive energy balance and whilst not foraging a net energy loss. As the proportion of the day spent foraging is theoretically increased, the total net return from foraging increases, whilst the total cost of the non-foraging period decreases. At some critical foraging time the net energy gain in the foraging period equals the energy expenditure in the non-foraging period. This is the required foraging time to achieve a positive energy balance (FT_0).

FT_0 's were evaluated using an iterative calculation. The time spent foraging was increased by increments of one hour until the calculated daily energy balance was positive. The energy balance estimates were then plotted on foraging time and FT_0 was interpolated as the foraging time with an energy balance of 0. (An example is shown in Appendix two.)

FT_0 at Skinflats and Culross, against temperature, at windspeeds of 0 and 8 m s⁻¹ for Early and Late Winter are shown in Figs. 100 and 101 respectively. Since densities of the most profitable items (large worms and large Hydrobia) were relatively constant between Early and Late Winter, the relationship between FT_0 and temperature was almost

FT_0
 hours foraging 24 hours^{-1}
 to achieve a 24 hour energy
 balance

Redshank

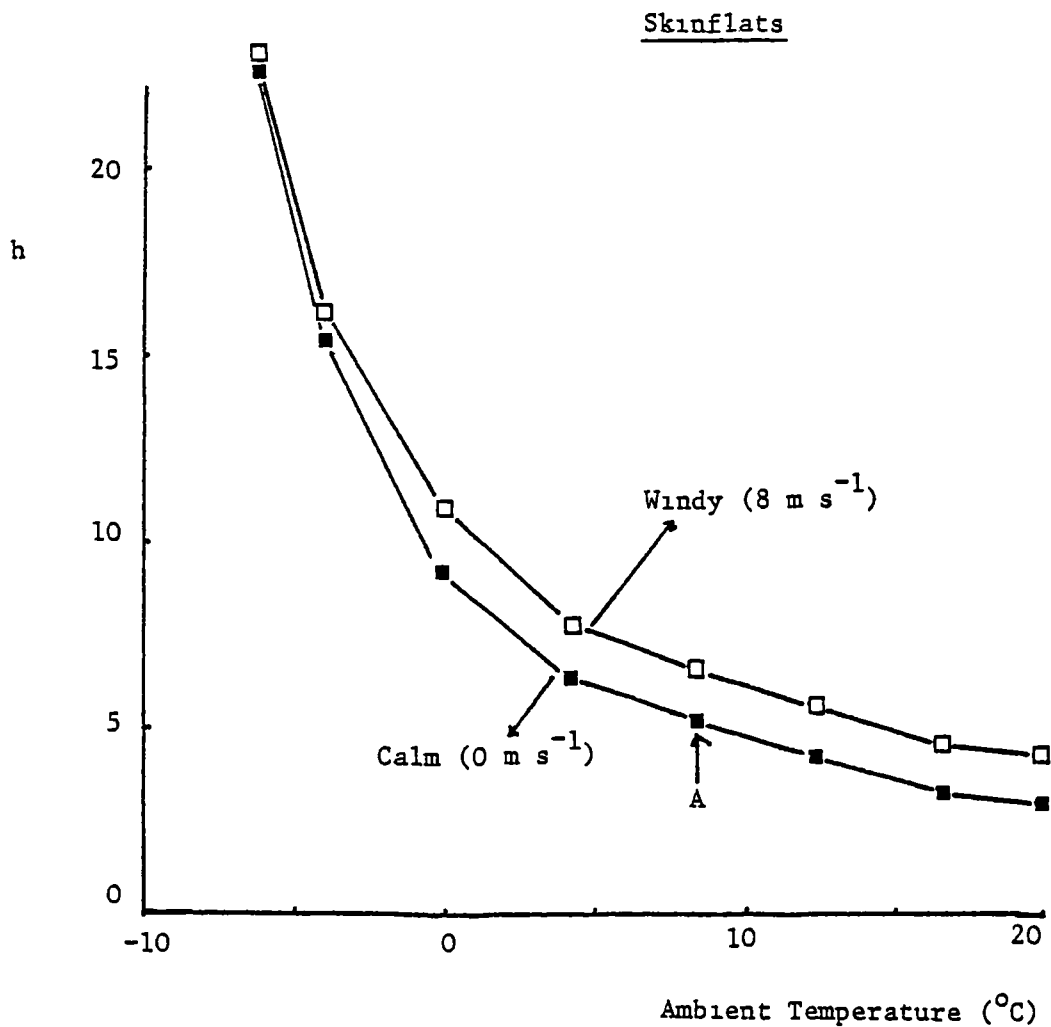

Fig 100 FT_0 (hours foraging per 24 hours to achieve a positive energy balance) against ambient temperature in calm (0 m s^{-1}) and windy (8 m s^{-1}) conditions by Redshank feeding at Skinflats, in Early Winter (The calculation of point A is shown in Appendix 2)

hours foraging 24 hours⁻¹
to achieve a 24 hour energy
balance

Redshank

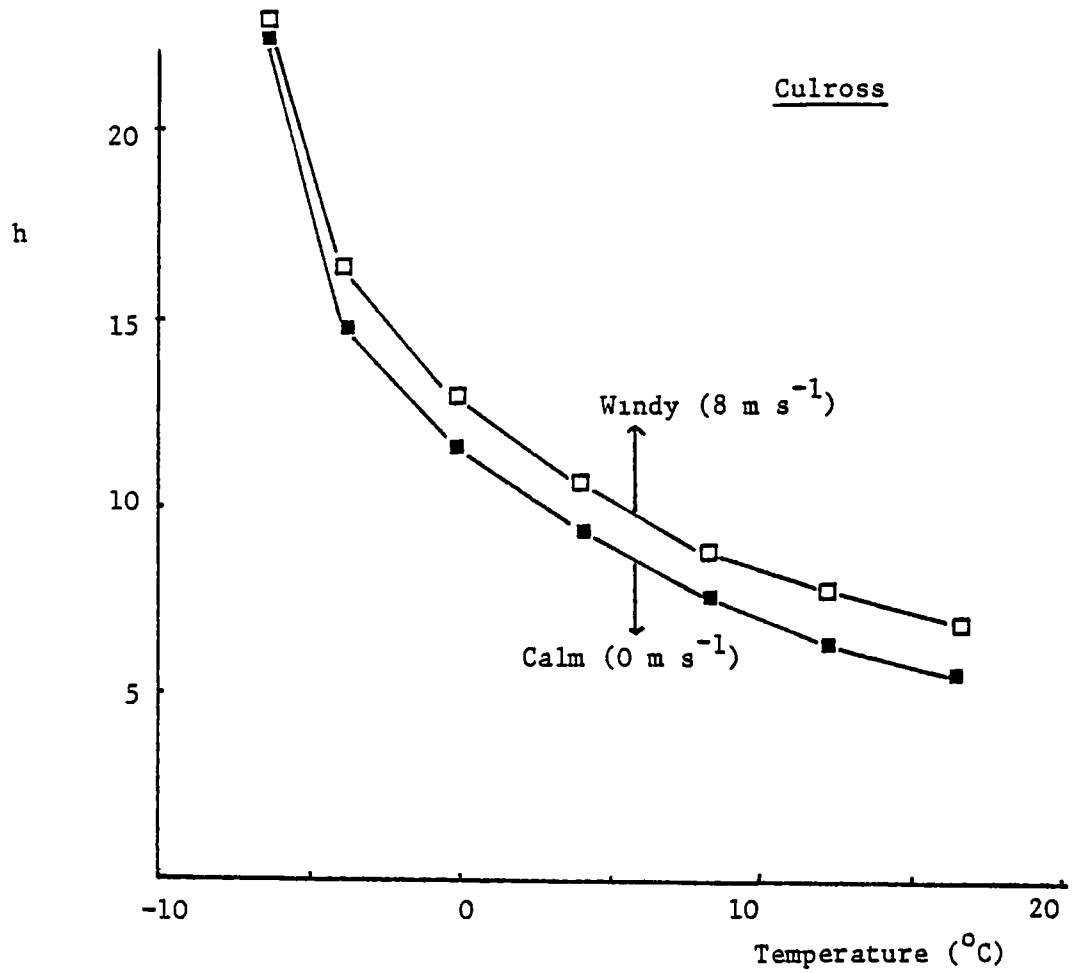

Fig 101 FT₀ (hours foraging per 24 hours to achieve a positive energy balance) against ambient temperature in calm (0 m s⁻¹) and windy (8 m s⁻¹) conditions by Redshank feeding at Culross, in Early Winter

identical in the two seasons.

Mudflat exposure varied with the tidal cycle and tidal height of the site. Low lying sites (e.g. Culross) were exposed longest on Spring tides, whilst upshore sites were exposed for longer on neap tides. The characteristic juxtaposition of tidal and diurnal cycles on the Forth meant the number of daylight hours during which each site was available varied in a systematic manner with tidal height in each season (Fig. 102). By interpolating the number of daylight hours each flat was available on the required foraging times (Figs. 100 and 101), the severest conditions in which Redshank could still achieve a positive energy balance by daylight feeding only were defined (Table 48), for neap and Spring tides.

At Skinflats Redshank were able to maintain positive daily energy balances at temperatures above about 0.5° on neap and 4°C on spring tides by daylight feeding only in Early Winter. The average daily air temperature at Skinflats in this season (7.5°C Phizacklea, pers. comm.) was above these limits. In Early Winter therefore Redshank only rarely encountered conditions in which they were unable to achieve a positive daily energy balance, by daylight feeding only.

In Late Winter shorter days meant the number of daylight hours Skinflats was exposed was lower than in Early Winter (Fig. 102). The severest conditions in which Redshank feeding during daylight only, could attain a positive daily energy balance, were milder than in Early Winter, and averaged about 4°C on neap and 10°C on spring tides. The average daily air temperature in Winter on the Forth (3°C Phizacklea pers comm) was below these limits. Hence, Redshank feeding in daylight only, at Skinflats would commonly suffer 24h. energy deficits, in Late Winter.

At Culross the uppershore has been reclaimed and the mudflat is all

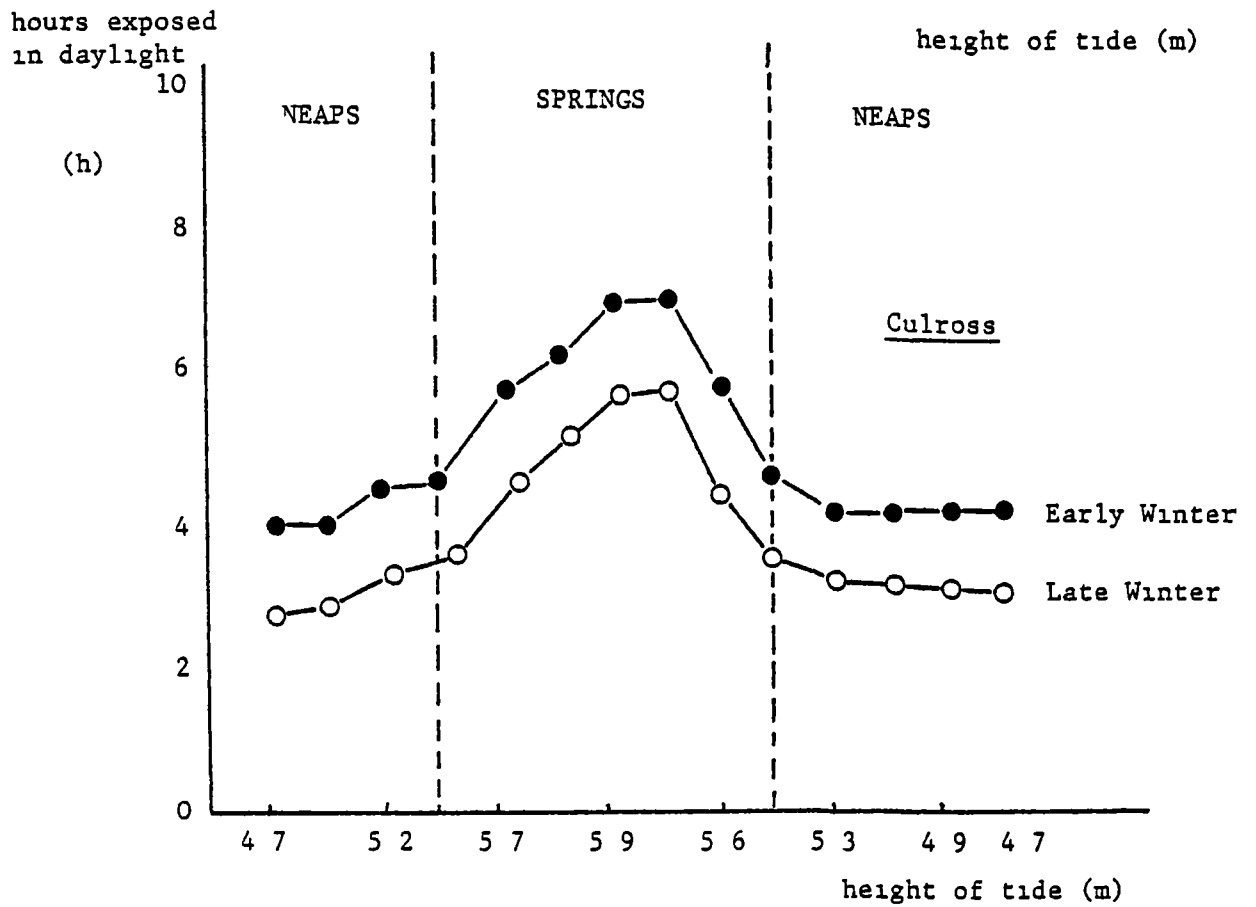
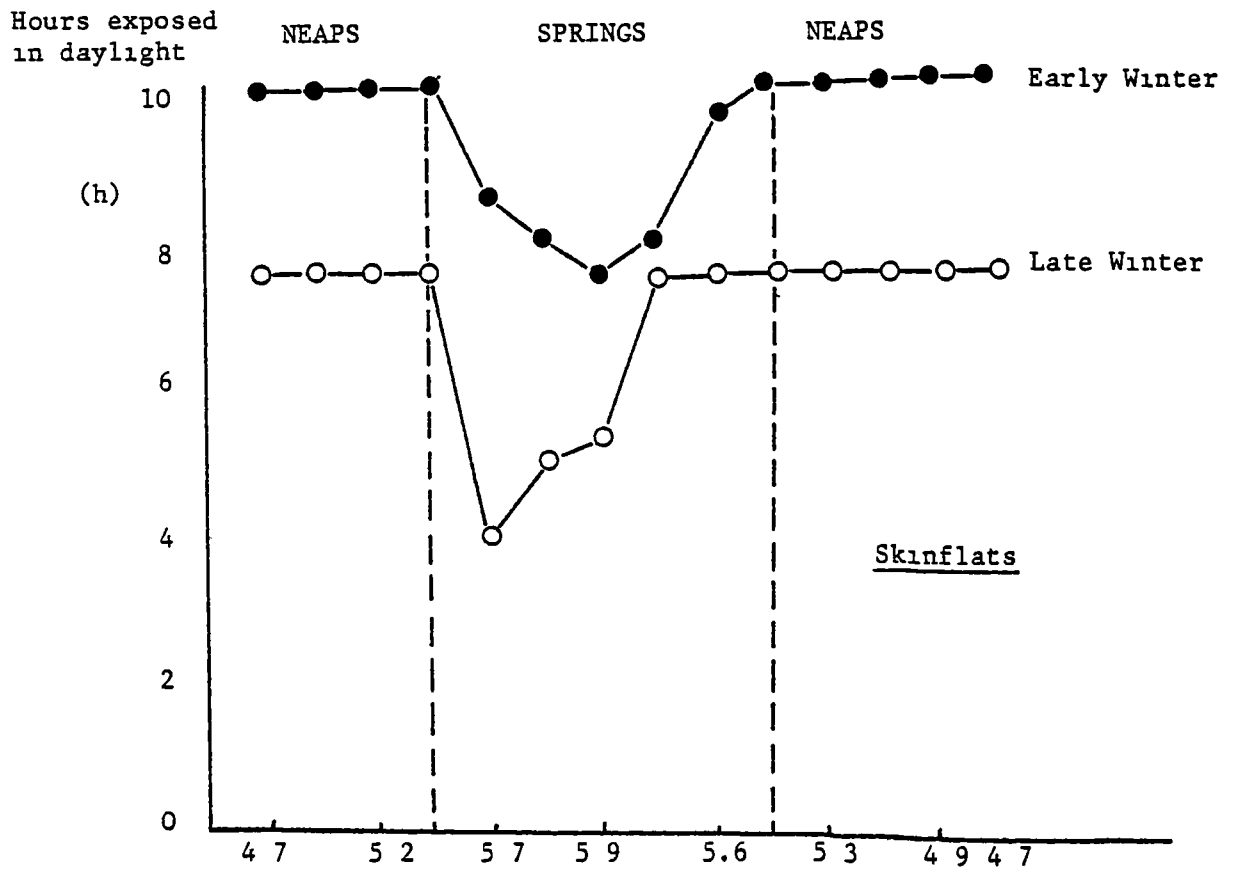

Fig 102 Hours the mudflats at Culross and Skinflats were exposed in daylight, in Early and Late Winter, throughout a typical neap-spring-neap tidal cycle

Table 48

Severest conditions (temperatures) at which Redshank could still achieve positive energy balances by foraging in daylight only, in Early and Late Winter, at Culross and Skinflats, on neap and spring tides, at low and high windspeeds

| Season | Site State of tide | SKINFLATS | | CULROSS | |
|--------------|--------------------------------|-----------|--------|---------|--------|
| | | neap | spring | neap | spring |
| Early Winter | Calm (0 m s^{-1}) | -0.5 | +2.0 | NP | +8.0 |
| | Windy (8 m.s^{-1}) | +1.0 | +4.0 | NP | +12.0 |
| Late Winter | Calm (0 m.s^{-1}) | +3.0 | +8.5 | NP | +12.5 |
| | Windy (8 m s^{-1}) | +5.5 | +12.0 | NP | NP |

NP - Not possible to achieve energy balance by daylight foraging in any conditions.

low lying. On the highest springs, it was exposed for a maximum of seven daylight hours, in Early Winter. On neap tides the exposed period in daylight was sometimes as short as four hours. In Late Winter the hours of exposure in daylight were even shorter (Fig. 102). In consequence the severest conditions at which it was still possible to attain a positive energy balance by daylight feeding were milder than at Skinflats (Table 48). On neap tides it was not possible to achieve a positive daily energy balance, in any conditions, in either season. On spring tides it was only possible to achieve a positive daily energy balance above about 10°C in Early Winter and above about 12°C in Late Winter. Both of these temperatures are above the mean daily air temperatures recorded on the Forth in these seasons (above). At Culross therefore Redshank would almost never achieve a positive daily energy balance if they only fed during the time the mudflat was exposed in daylight.

There are several possible methods Redshank foraging at Culross (and Skinflats in Late Winter) may have used to meet the excess energy requirements after daylight foraging.

- (i) High tide feeding - At Skinflats Redshank were often observed to continue foraging in the salt marsh, after the mudflat was completely covered. This feeding continued for up to an hour. At Culross reclamation of the upper shore and salt marsh meant this was not possible
- (ii) Inland feeding - Redshank were encountered only infrequently during systematic checks of the inland fields around both Skinflats and Culross (max. n = 3) (see also Bryant (1981)). This behaviour is common however at other sites on the Forth where up to 50% of birds from the adjacent bays may be recorded feeding inland (Bryant pers.comm.). Heppleston (1971) showed that suitability of inland

fields to Oystercatchers was related to the abundance of earthworms (Lumbricus sp) and the time since the field was put under the plough. Since the fields adjacent to the study sites were ploughed almost annually, they may have been unattractive to Redshank. Whilst this may account for the low numbers of inland feeding Redshank at Skinflats, inland feeding Oystercatcher were common around Culross (below), which suggests these fields were suitable for inland feeding. Inland feeding did not appear therefore to be a preferred habit at these sites.

(iii) Night feeding - Observations at night were made on a single tide in each each period, when weather conditions (clear sky and full moon) afforded maximum visibility (total n = 4). Redshank were encountered in all the seasons, but it was not possible to assess numbers or make any observations on foraging. Previous studies have suggested Redshanks feed at night using the tactile method (Goss Custard 1969, Greenhalgh 1975). At some sites energy gains at night may perhaps therefore exceed gains in the day At Culross tactile foraging gains are probably lower than when visual foraging. Assuming tactile intake equalled 70% of visual foraging gains, night feeding would reduce the severest conditions at which a 24 hour energy balance could be achieved to approximately -2°C on spring tides but to only between 7 and 11°C on neap tides, in both seasons

(iv) Feeding at other sites - Because achieving an energy balance at Culross is difficult on neap tides, the birds may abandon Culross and feed at other sites during the day or night on these tides. Some evidence, from counts of the number of Redshanks feeding within the Culross bay at low water support this hypothesis since there

were significantly fewer Redshank feeding in the bay on neap tides (Neaps counts = 4, mean n birds = 93.7, σ = 42, Springs counts = 8, mean n birds = 148, σ = 31.5, t = 2.35 (p < .01). No night counts are available. If Redshank do forage elsewhere, e.g. Skinflats, on neap tides, they are probably able to achieve 24h. energy balances at temperatures down to between -2 and -4°C .

Because areas of mudflat suitable for foraging Redshank were available, on the Forth, for approximately 20-24h. of each day, Redshank were probably able to achieve positive daily energy balances in most conditions when the temperature was greater than -4 to -2°C , in both Early and Late Winter. Under the conditions in which most of the foraging observations were collected (2 to 17°C), Redshank probably needed to forage for only between 20 and 40% of the available foraging time. Maximizing the rate of net energy intake during the foraging time might have been relatively unimportant in its consequences for achieving an energy balance.

Calculations of the daily energy expenditure when Redshank are in energy balance (FT_0) as a multiple of BMR at various temperatures and windspeeds are shown in Table 49. On average in Early Winter Redshank probably expend 2.5 to $2.8 \times \text{BMR day}^{-1}$ whilst in Late Winter they expend 2.8 to $3.2 \times \text{BMR day}^{-1}$. These values are only 70 to 80% of the 'maximum sustained working level' of parental birds tending nestlings [$3.8 - 4.2 \times \text{BMR}$] (Drent and Daan 1980) which is inferred to be the ceiling for adult performance and at a similar level to estimates for other non-breeding non-moulting birds ($2.6 \times \text{BMR}$, Drent and Doornbos in Drent and Daan 1980). These data lend further support to the suggestion that Redshank in Winter are commonly under little pressure to maximize their net energy intake whilst foraging.

Maximizing the rate of net energy gain whilst foraging may have been

Table 49

Daily energy expenditure of Redshanks as a multiple of BMR when in energy balance, at various temperatures and windspeeds in Winter of the Forth estuary.

| Temperature °C | Windspeed | |
|-------------------|-----------------------------|------------------------------|
| | Calm 0 m.s ⁻¹ | Windy 8 m.s ⁻¹ |
| 16 | 1.84 | 2.17 |
| 12 | 2.03 | 2.36 |
| 8 | 2.4 | 2.73 |
| 4 | 2.79 | 3.12 |
| 0 | 3.23 | 3.56 |
| -4 | 3.84 | 4.17 |

Mean Temp Early Winter = 7°C
Mean Temp Late Winter = 3°C

more important in Spring, because although daylength was longer than in Late Winter, and conditions milder, Redshank were preparing to migrate. Relatively few Redshank breed on the Forth because the area of saltmarsh is small. Before migrating, waders deposit fat stores to fuel the migration. Generally these stores are large, in Redshank up to 20% of the lean mass (25-30 g of fat - Minton 1975, Glutz 1977), with the majority deposited rapidly over a relatively short period of about 14 days (Eades and Okill 1977, Elliott et al. 1976, Prater 1974, Pienkowski et al. 1979).

If Redshank were to forage for the entire available feeding period (day and night) and their night energy gain occurred at only 70% of visual rates, at 7°C (the mean daily air temperature in Spring on the Forth) the daily energy surplus would equal approximately 250 kJ. Fat has an energy content of about 40 kJ.g⁻¹ (Klieber 1967). In theory therefore the energy surplus equals approximately 6.25 g of fat per day. This calculation takes no account of the costs associated with wind. Even including a moderate wind (8 m.s⁻¹) the energy surplus would still exceed an equivalent of 4 g of fat per day. Maximum mass gains in premigratory Redshank probably occur at a much slower rate of 1.5 to 1.8 g.day⁻¹ (Minton 1975).

These data suggest it is unlikely Redshank are under strong pressure to maximize the rate of net energy gain in Spring. These calculations, however, take no account of the energy costs associated with the anabolic metabolism of fat storage. If the conversion of ingested energy to fat was only 19 - 26% efficient, as in nestlings (Drent and Daan 1980) Redshank would need to forage for all the available time to achieve the mass gains recorded. In these conditions Redshank may be selected to maximize the rate of net energy gain, as observed.

Since it is implicitly assumed animals optimize some function in

foraging behaviour because natural selection favours individuals following that optimization strategy, temporal changes in the nature of selective pressure would be expected to effect changes in the optimized function, and therefore behaviour. Hence in mild Winter conditions maximization of protein intake by Redshank may be selected for, but in Spring pressure to rapidly deposit fat may select individuals which maximize net energy intake. Changes in selective pressures may occur over shorter time scales. For example, as temperature falls, the proportion of the available foraging time required to achieve a daily energy balance increases (fig. 100 and 101). At temperatures below about -2°C Redshank might be selected to maximize net energy gain as opposed to protein gain, which appears to occur in milder temperatures. Unfortunately data for foraging Redshank at these temperatures were not available to test this hypothesis.

Temporal changes in the optimized function over the long or short term, may have important consequences for benthic community structures. Barnes and Hughes (1982) suggest Hydrobia and Corophium (arenaria) may competitively exclude each other from small (100 cm^2) areas. These species may co-exist therefore because predation by Redshank, which switches between a diet including Hydrobia when maximizing energy intake and Corophium when maximizing protein intake may restrict each species from competitively excluding the other. A series of mild winters therefore might be expected to favour populations of Hydrobia whilst a number of harsh winters might favour Corophium. Results of detailed sampling over small areas for long periods are not available to test this hypothesis.

On the Ythan estuary (N.E. Scotland), Redshank and other avian predators have been excluded from small areas of mudflats. Within these areas removal of predators has not resulted in competitive exclusion of

either Hydrobia or Corophium (Raffielli pers. comm.), in conflict with the above hypothesis. The duration of this experiment (one winter) may have been insufficient to result in changes which were detectable by the sampling employed. Temporal changes in prey preference, as a result of changes in optimized functions, in response to changes in selective pressure, may potentially influence the diversity of communities, containing species which would competitively exclude each other, in a more subtle manner than the 'functional link' influence proposed by Paine (1980).

In addition, differences in physiological history may result in different optimization functions for different individuals. For example, resident birds may forage to maximize protein intake, whilst migrants may maximize net energy intake. It might therefore be possible to observe two individuals foraging adjacent to one another, in identical conditions, but selecting different prey. Such behaviour differences have been observed on the Ythan (Goss Custard 1977b) and on the Forth (pers. obs.), albeit on birds of unknown physiological history.

The second discrepancy between predicted diets, of all models, and diet observed in the field was 'partial preference' of low profitability prey. There are several possible explanations of this behaviour. These are detailed below in the context of partial preference in the diet of the Oystercatcher. A probable explanation of partial preference in the Redshank was that the birds found it difficult to discriminate the profitabilities of prey hidden in burrows.

(ii) 'Prizing' Oystercatchers

There were two major discrepancies between the observed and predicted diets. The largest mussels were the most profitable but were not the most preferred. Secondly, some mussels smaller than the

observed selection point (B in Fig. 90) were occasionally included (= partial preference).

Goss Custard et al. (1980) also found the risk of predation for mussels by Oystercatchers, on the Exe, was greatest in the classes 45-50 mm and lower for larger sizes, although no profitabilities were given.

Differences between the predicted and observed diet may have occurred because of errors in the estimates of profitability, or because there was some other selective, but non-energetic, disadvantage associated with these mussels. Since it is unlikely that much error occurred in the estimates of energy content or handling time (see section 3.12(d)) the most likely source of error was estimates of false recognition and unsuccessful manipulations rates, or of energy expenditure during foraging, which was inferred from the Redshank metabolism work (section 3.14) and assumed constant across prey sizes.

If Oystercatcher were less successful at manipulating larger mussels it would be expected the rates of unsuccessful manipulation would increase with the density of large mussels. This was not the case (Fig. 49b) but the absence of any relationship may simply reflect the fact that the longest mussels were not preferred. Sutherland (1982b) found Oystercatchers foraging on large Cockles made more unsuccessful manipulations and this may be similar in mussels. If the largest mussels had greater unsuccessful manipulation rates this would decrease the profitability of these prey. A decrease in success rate from 3.8% to 1% (Table 15) of investigations would reduce the profitability to 17.5 J.s^{-1} - a lower rank than the observed preferred prey items (Fig. 90). Since changes of this order are probably realistic this may explain why the largest mussels are not the most preferred items.

The second source of discrepancy between predicted and observed diets was partial preference. Several mechanisms have been proposed to

account for partial preferences.

(a) Individual differences

Individual differences in foraging ability would lead to positioning of individual inclusion points around a mean predicted value. Diets observed across individuals might reflect these differences. Although handling times showed considerable variability, (Fig. 45) this appears to be a result of differences between mussels more than differences between Oystercatchers. If an Oystercatcher was so inefficient that its diet included items of the lowest profitability recorded as ingested, its mean net energy gain whilst foraging would have to be lower than 8 J.s^{-1} (the lowest mean profitability of an observed ingested size class). Even in relatively mild conditions (9°C) these birds would have to feed for 12 h day^{-1} to achieve a positive energy balance (see below) and in Late Winter when earthworm availability is low and inland feeding unprofitable (see below) it is unlikely such individuals could survive within the population.

(b) Sampling

Krebs et al. (1979) suggest animals may select the odd item from outside the optimal set because they are not omniscient concerning fluctuations in model parameters (contra to the assumptions of most models), and must sample the environment for information about prey profitabilities for example. Whilst this may be probably correct, fluctuations in profitability within mussels sizes occurred relatively slowly (seasonally) and did not lead to changes in rankings (in this study), hence profitability, sampling might be expected, but much less frequently than observed

(c) Discriminant ability

Houston et al (1980) and Rechten et al 1980, were able to show that Great Tits (Parus major) partially preferred mealworms in drinking straws

size set. This would lead to partial preference (see Figure 104). The degree of partial preference will depend on the amount of variability in profitability explained by changes in the classed variable (most often size). Partial preference might be expected in the Oystercatcher because the explained variability in profitability by size was low.

Prizing Oystercatchers at Culross did select within size classes. Across sites they consistently selected mussels with relatively small posterior adductor muscles, and with relatively few surface Barnacles. Selection for relatively tall and wide mussels (Appendix 1), which would be expected if selection occurred at random, or for light shells which has been shown in hammerers on the Exe (Goss Custard et al. 1981), was not shown to occur. Selection of mussels with small adductor muscles is compatible with this view, because this variable probably exerts a large influence on handling time (see section 4.8). Selection for mussels with fewer Barnacles is more difficult to explain. There is a positive relationship between percentage barnacle coverage and the probability of the mussel valve edges being deformed. Oystercatchers consequently select mussels with less deformed shells (Table 50). Possibly deformed mussels are more difficult to prize apart because it is difficult to force the bill between the valves. High variability of profitability within size classes coupled with good discriminant ability in the predator, probably explains the partial preference in the 'prizing' Oystercatcher.

(iii) 'Hammering' Oystercatchers

Preference for smaller mussels than predicted was more marked in 'hammerers', despite the fact that profitabilities of the large mussels were greater in hammerers. Similar avoidance of the largest mussels was reported by Norton Griffiths (1968). Reductions in profitability as a result of a drop in the successful attack rate from 5.3% (Table 15) to

Deterministic Model

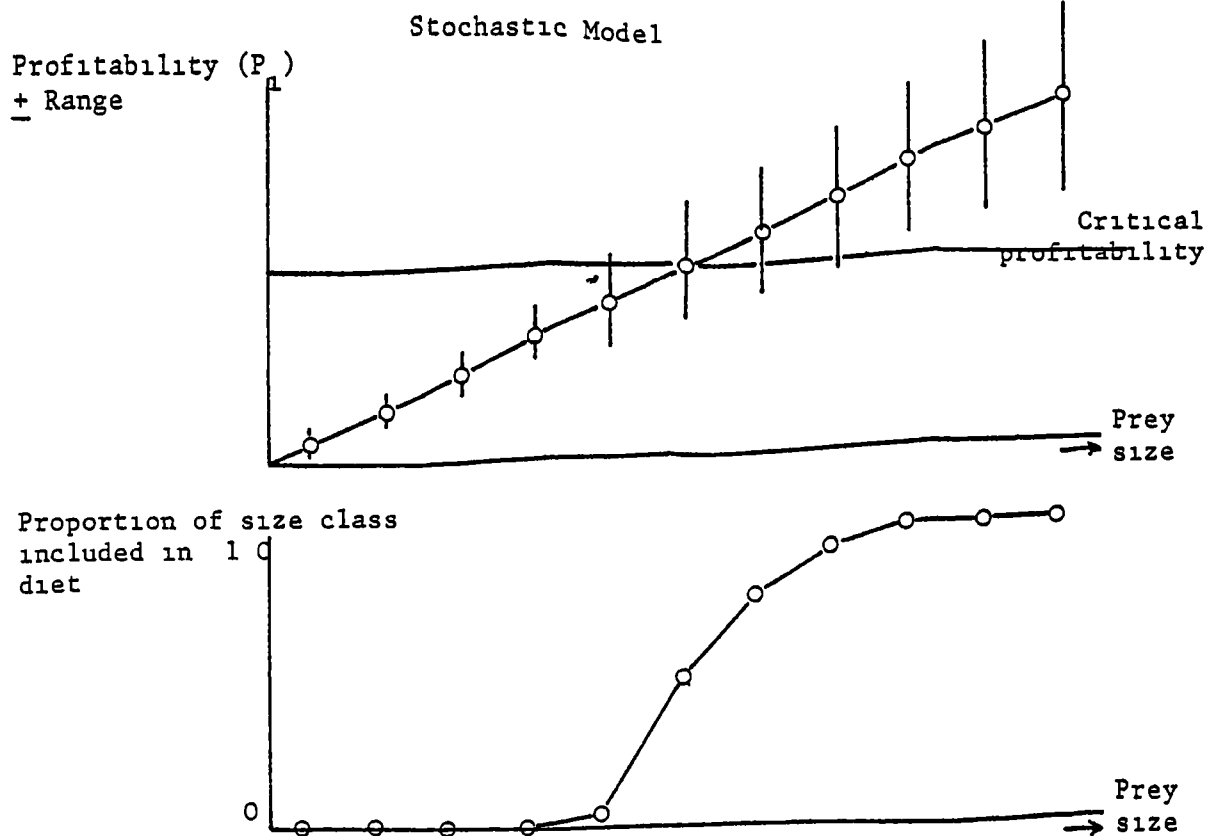
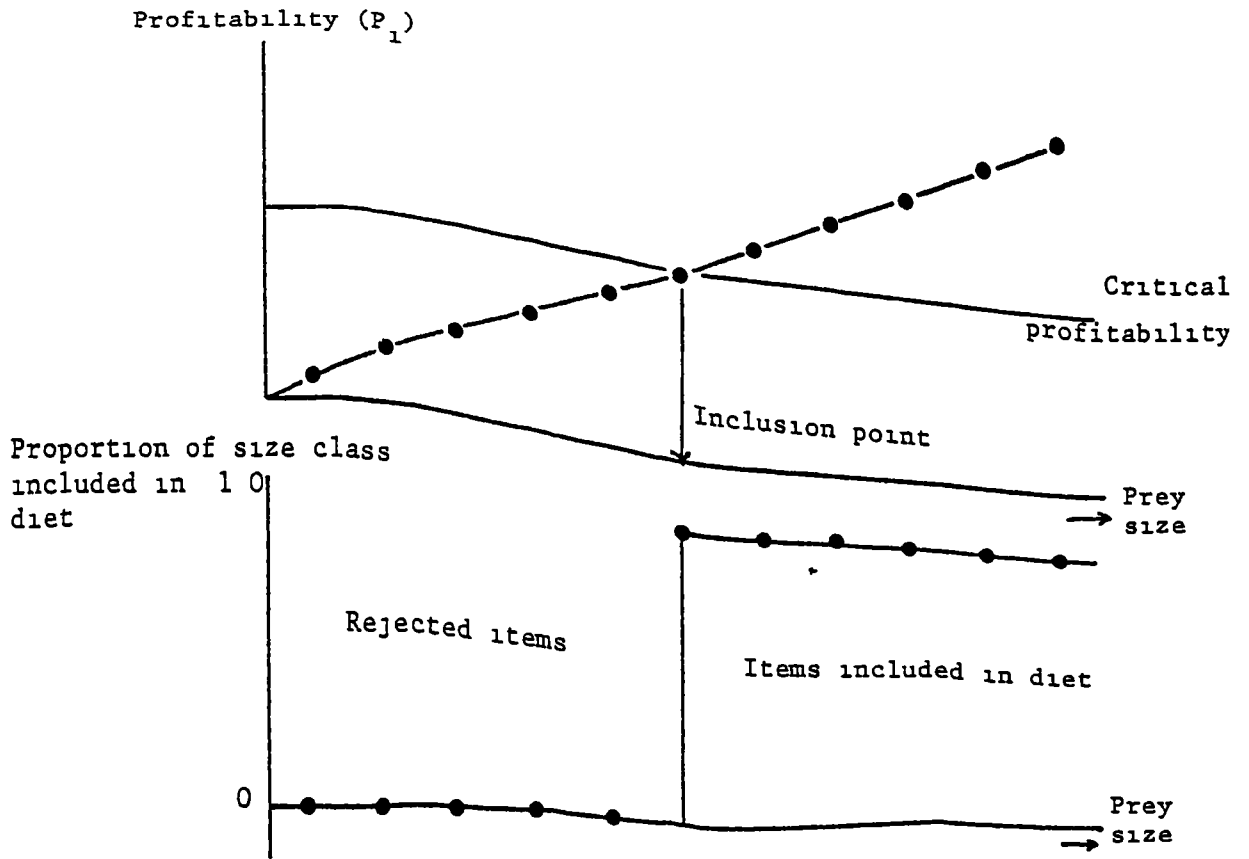

Fig 103 An explanation of partial prey preference diet choice predicted by a deterministic and stochastic model of profitability against prey size

Table 50

Deformation of the posterior margin and all margins of mussels selected by Oystercatchers and collected in the environment (all mussels in both classes > 4 cm long)

| Season | Plot | SELECTED | | | | NOT SELECTED | | | |
|--------|------|----------|----------------------|-------------------|------------|--------------|----------------------|-------------------|-----------|
| | | n | n def on post margin | def on any margin | % deformed | n | n def on post margin | def on any margin | %deformed |
| LW | 5 | 115 | 25 | 35 | 30.4 | 14 | 7 | 8 | 57.1 |
| EW | 6 | 39 | 19 | 26 | 66.6 | 36 | 10 | 27 | 75.0 |
| EW | 7 | 40 | 7 | 13 | 32.5 | 36 | 10 | 28 | 77.8 |
| LW | 7 | 28 | 7 | 8 | 28.6 | 34 | 14 | 21 | 61.8 |
| LW | 6 | 40 | 11 | 4 | 10.0 | 33 | 9 | 21 | 63.6 |
| LW | 5 | 69 | 13 | 18 | 26.1 | 64 | 19 | 37 | 57.81 |
| LW | 8 | 60 | 7 | 10 | 16.7 | 35 | 11 | 23 | 65.71 |
| LW | 2 | 23 | 9 | 14 | 60.9 | 37 | 9 | 18 | 48.6 |
| LW | 4 | 40 | 16 | 28 | 70.0 | 41 | 21 | 34 | 82.9 |
| TOTAL | | 454 | 114 | 156 | 0.34 | 330 | 110 | 217 | 0.637 |

1%, reduces the profitability of the largest mussels from 84 J s^{-1} to 32 J.s^{-1} . This still exceeds the profitability of the preferred classes (3.25 to 4.75 cm) which vary between 11.9 and 27.3 J s^{-1} .

A second error in the estimate of profitability may be the estimated cost of handling which was assumed to equal the cost of probing in Redshank ($= 1.9 \times \text{BMR at } T_{1c}$). As hammering appears a more strenuous activity this may be an underestimate (but see section 4.10). To reduce the profitability below 11.9 J.s^{-1} would require hammering to exceed $10 \times \text{BMR}$ (in addition to the reduction in success rate). This estimate is the same order as estimates of the cost of flight (Hails 1979). It seems most improbable therefore that the underselection of large high profitability mussels can be wholly explained by inaccuracies in the estimates of profitability.

Hammerers presumably avoid large mussels because foraging on them reduces fitness in some other non-energetic manner. A possible source of such a reduction in fitness is an increase in the probability of bill damage when hammering large mussels

Other predators may also injure themselves when handling prey, for example, Lions (Felix leo) may be injured when felling Zebra (Zebra zebra) because the prey may fall on them (Bertram 1978). Whether this modifies the diet to avoid such 'risky' prey is unknown but is suspected to occur (op cit.) - generally the probability of self injury is likely to increase as the prey become relatively large. In predators exploiting relatively large prey the probability of self injury may be an important factor influencing diet choice.

(iv) Why do Oystercatchers not eat mussel shells?

Mussel shells have approximately the same energy content as the flesh (section 3.4) yet Oystercatchers leave the shells behind. Ingesting shells has no disadvantage in terms of decreasing the predator

velocity because shells are obviously encountered at the same time as the flesh. To be included in the diet therefore the profitability of shells would have to exceed the maximum net energy gain

The organic portion of shells is fibrous protein (Price et al. 1974), which is assumed to have an energy content of 22.2 kJ g^{-1} . With an assimilation efficiency of 70% (section 3.7) the shells of the largest mussels would have to be ingested within 330s to be profitable. This does seem possible. Possibly Oystercatchers reject mussel shells because ingesting them would cause damage to the gut or because the protein is bound in such a manner that it cannot be digested. These alternatives require further investigation.

(d) Daily energy budget of Oystercatcher and maximization of net energy gain

As Oystercatcher selected prey of a single species, in which energy and protein contents did not vary with body length, the predictions of the gross energy and gross protein maximisation models were identical. In addition, including costs had no effects on diet choice predictions, hence the predictions of all three maximization models were the same. Prizing Oystercatchers probably did feed on those mussels which maximized either net or gross energy or protein intake, but distinguishing between these hypotheses was not possible.

By constructing a daily energy budget and comparing the time available with that required to achieve a 24 hr energy balance (FTo), it was possible to assess how consistent a strategy of net energy maximization is with the variable opportunities to achieve energy balance. Theoretical maximum net energy gains, across plots, on each bed, were greatest on the lower bed (section 2.2) where larger mussels were more abundant (section 3.2). As 'prizing' Oystercatchers did not select the most profitable prey, actual net intakes were approximately

20% lower than the theoretical maximum. Since all the parameters of the net energy gain equation were not significantly different between Early and Late Winter, the predicted actual net energy gains were not significantly different between these seasons. Mean net energy intake, across plots on each bed, was directly related to temperature.

As in Redshank (section 4.13), Oystercatcher are theoretically able to forage for all the time the mussel beds are available, but in practice do not because they must perform other activities which are incompatible with foraging. Environmental conditions did not appear to reduce foraging ability in the Oystercatcher, unlike Redshank. Time budgets of five individual Oystercatchers in Winter, at windspeeds of 6 to 9 m.s^{-1} , for over an hour each, suggested the time spent not foraging was less than 2% of the total time. Time budgets of 'foraging' Oystercatchers also reveal that the majority of time was actually spent foraging (Table 51). Time not foraging was therefore ignored.

Oystercatchers were never observed to fly as a consequence of disturbance by predators. The avian predators observed at Culross were either Kestrel or Sparrowhawks, both of which select prey which are much smaller than Oystercatchers (Witherby et al. 1935). Oystercatcher did not respond to these predators presumably because they presented no threat. Possibly some disturbance did occur, but at a level which could not be detected, and so this was ignored.

As in Redshank, Oystercatcher flight speeds into and out of the roost were mostly influenced by the wind velocity. On average, travel between roost and feeding sites, and return, occurred at a speed of 7.25 m.s^{-1} (mean of 31 readings at windspeed = 0) and ranged from 5.6 to 9.25 m.s^{-1} . The time to cover 4.5 km (see 4.12) at the mean speed equalled 10.5 minutes. This was assumed to be the time spent in flight per day. In the absence of any data concerning the time spent preening

Table 49

Time budgets of 'foraging' Oystercatcher

| Behaviour | Time observed (s) | % Time observed |
|------------|----------------------|-----------------|
| Foraging | 15,093.9 | 98.54 |
| Vigilant | 23.4 | 0.16 |
| Flight | 24.4 | 0.16 |
| Preening | 114.4 | 0.75 |
| Aggression | 56.6 | 0.37 |
| Calling | 2.5 | 0.02 |
| TOTAL | 15,315.2 | 100.0 |

and washing, this time was assumed to equal that observed in Redshank (section 4.12). All energy expenditures were inferred from estimates in Redshank (section 3.18). FT_0 was calculated as in Redshank (section 4.12, and Appendix 2).

FT_0 for each mussel bed, against temperature, at windspeeds of 0 and 8 m.s^{-1} are shown in Fig. 104. The mussel beds were both low lying, in common with most other mussel beds in Britain (Bayne 1976). Daylight exposure times of each bed were consequently relatively short (Fig. 105). The severest conditions in which Oystercatchers, foraging exclusively on each bed, could achieve positive daily energy balances, were defined by interpolating the exposure times on the required foraging times (Table 52).

In Early Winter in calm conditions, Oystercatcher were able to achieve positive energy balances down to approximately 5.5°C on neap and 3°C on spring tides. These temperatures were lower than the mean temperatures recorded on the Forth in that season (7°C) which suggests in calm conditions Oystercatcher were probably able to achieve positive energy balances on most days. In windy (8 m.s^{-1}) conditions, on the other hand, Oystercatchers were only able to achieve positive energy balances on the upper bed on spring tides and then only down to 7°C

In Late Winter, day length was shorter and daylight hours of exposure similarly so. Even in calm conditions therefore, Oystercatchers could only achieve positive energy balances by feeding on the upper bed at temperatures above approximately 6°C , by daylight feeding only. When it was windy they could never achieve daily energy balances by daylight feeding only. Since the mean recorded air temperature in Late Winter equalled 3°C it is concluded, that daylight feeding would only result in a positive daily energy balance in calm conditions in Early Winter.

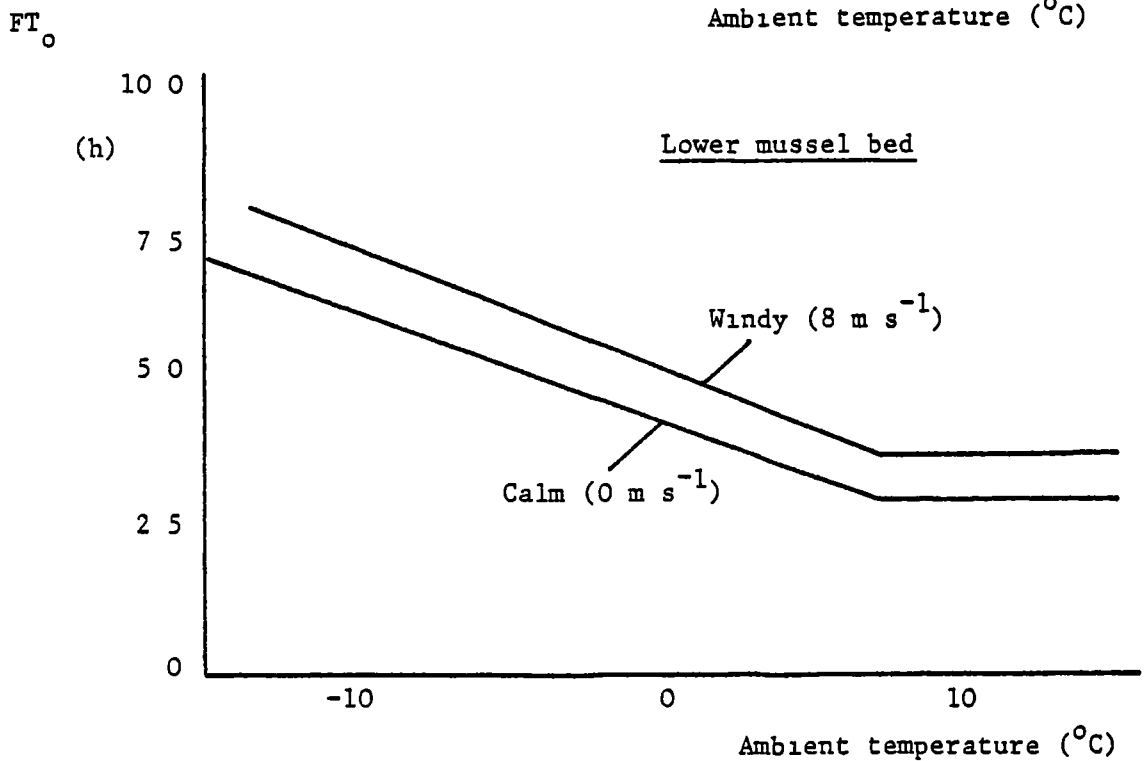
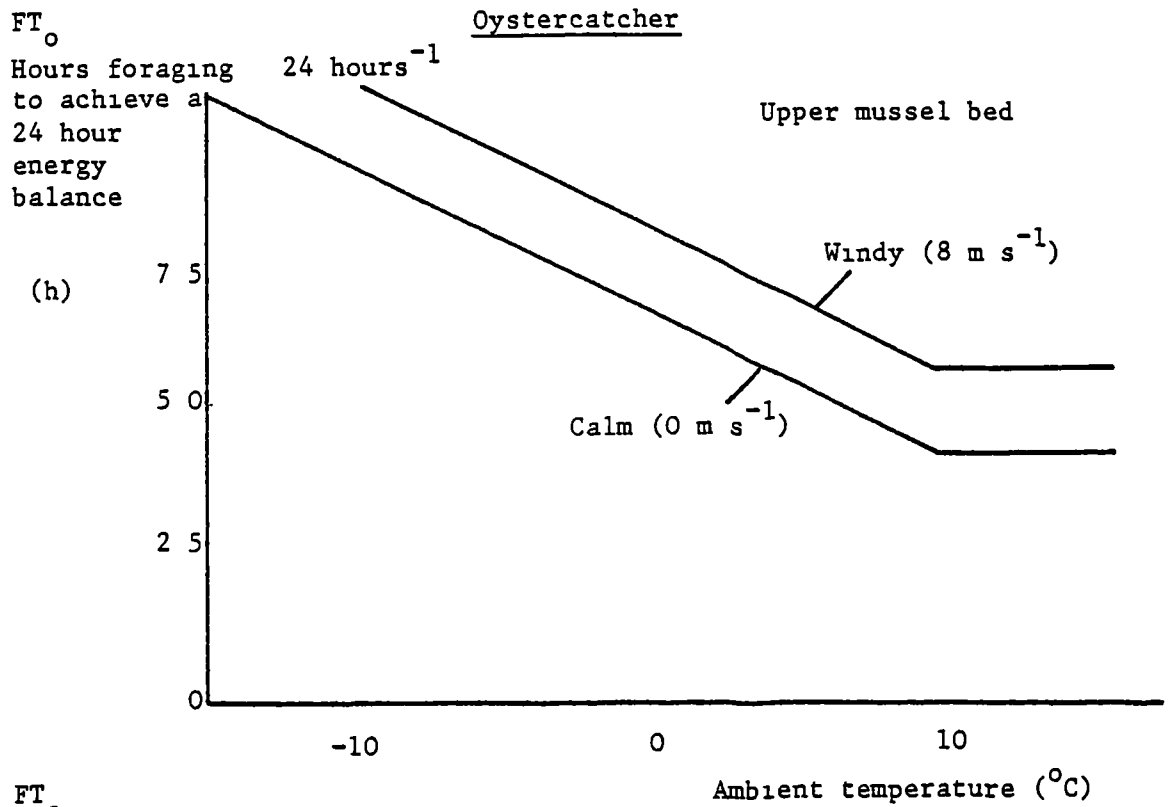

Fig 104 FT₀ (hours foraging per 24 hours to achieve a positive energy balance) against ambient temperature in calm (0 m s⁻¹) and windy (8 m s⁻¹) conditions by Oystercatchers feeding on the upper and lower mussel beds at Culross

hours exposed
in daylight

(h)

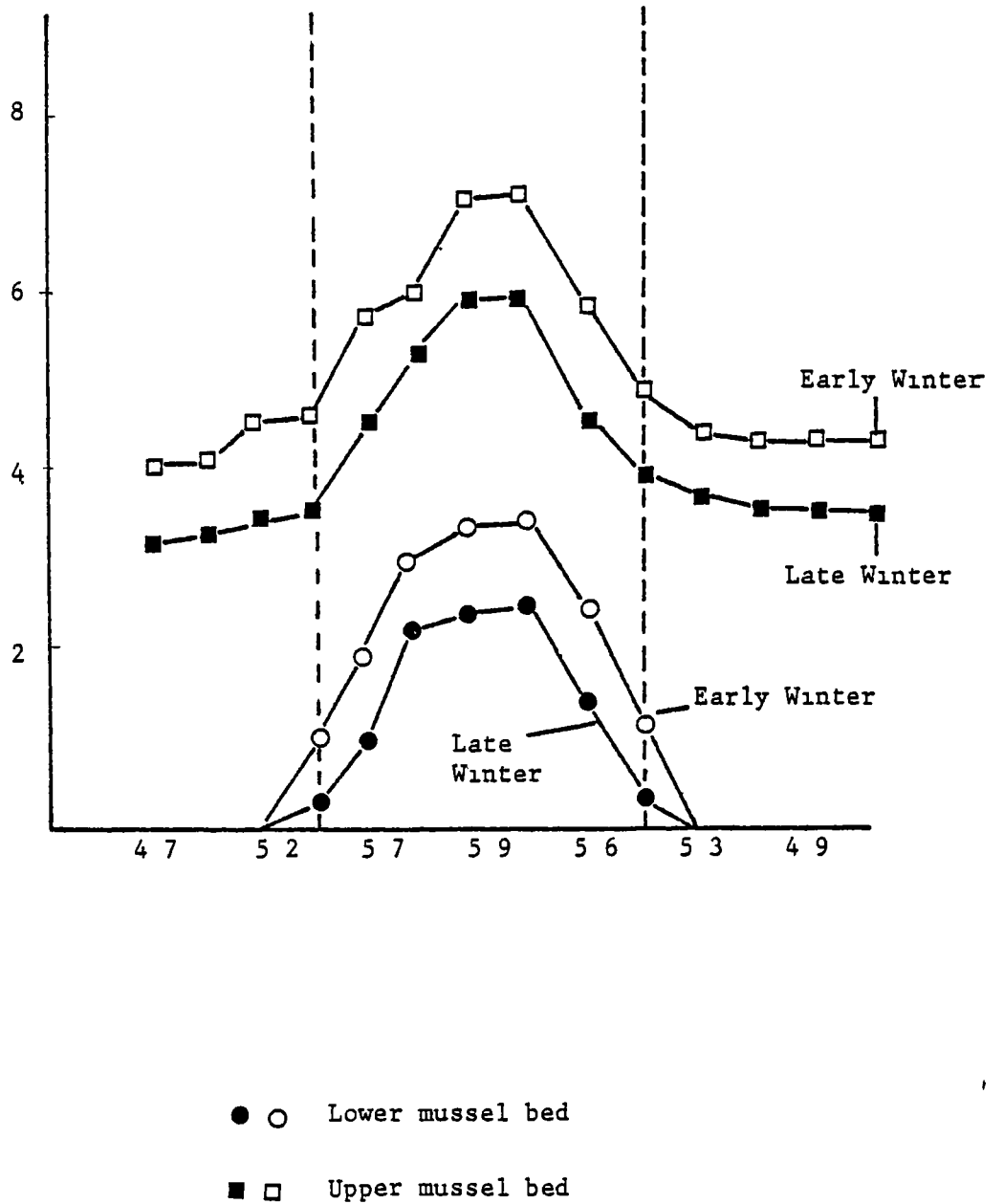

Fig 105 Hours the mussel beds at Culross and Skinflats were exposed in daylight, in Early and Late Winter throughout a typical neap-spring-neap tidal cycle

Table 52

Severest conditions (temperatures) at which Oystercatcher could still achieve positive energy balances by foraging in daylight only, in Early and Late Winter, on neap and spring tides, at low and high windspeeds for birds feeding on the upper or lower mussel beds.

| Season | Bed State of tide Conditions | Lower | | Upper | |
|--------------|--|-------|--------|-------|--------|
| | | neap | spring | neap | spring |
| Early Winter | Calm (0 m.s^{-1}) | NP | 4.0 | 5.5 | 2.0 |
| | Windy (8 m.s^{-1}) | NP | NP | NP | 7.5 |
| Late Winter | Calm (0 m.s^{-1}) | NP | NP | 7.5 | 4.5 |
| | Windy (8 m s^{-1}) | NP | NP | NP | NP |

NP - not possible to achieve energy balance by daylight foraging in any conditions

Since mussel beds are generally all low lying, Oystercatcher probably do not have the option of feeding at other exposed sites when the mussel beds are covered, because other mussel beds on the bays are also covered. To achieve 24 h energy balances they must either feed at night or in inland fields.

Observations around Culross bay suggest inland feeding occurs exclusively in Early Winter. It does not occur in Autumn when daylight hours available on the mussel bed are long and conditions mild, and also not in Late Winter when the favoured prey (earthworms, Lumbricus sp.) are less available (Gerrad 1967, pers. obs.). Penner (1981) found inland feeding around the same bay also increases between Autumn and Early Winter (no Late Winter observations made). Heppleston (1971) found inland feeding common throughout the winter, on the Ythan, but it was most common in November and December. In contrast, Goss Custard et al. (1981) found feeding by 'mussel feeders' relatively scarce on the Exe. Although Heppleston (1971) demonstrated great variability in the quality of inland fields for inland feeding, mostly related to the interval since ploughing, the lack of inland feeding on the Exe was not related to unsuitability of the fields because Oystercatchers specializing on other prey did feed inland. Possibly milder conditions on the Exe reduce the required feeding time to less than the available period, or these birds supplement their intake by night feeding.

Night feeding in the Oystercatcher is widespread (Heppleston 1971, Hulsher 1976, Greehalgh 1975, Goss Custard et al 1977). On the Forth Oystercatchers were present on the mussel beds at night in all the seasons but numbers could not be assessed. Heppleston (1971) found an increase in numbers foraging at night between Early and Late Winter, whilst Goss Custard et al (1977) found a decrease. The reliability of estimates of numbers of night-time foragers is probably low, yet

observations of foraging at night in mid winter support the hypothesis that Oystercatchers seldom achieve a positive energy balance by daylight feeding only (a similar conclusion is reached by Heppleston 1971).

If Oystercatchers do forage at night the severest temperatures at which they would still achieve positive energy balances are much lower. Estimates of the rates at which Oystercatchers feed at night suggest they are capable of achieving equal rates of intake to those observed in daylight, when feeding on cockles (Hulsher 1976, Sutherland 1982b). Night feeding rates on mussels are unknown. If it is assumed there is no reduction in the intake rate at night, Oystercatcher could probably achieve energy balances down to between -6 and -16°C , depending on windspeed and tidal cycle. In Early Winter when inland feeding is also possible these limits are reduced even further. This would suggest that Oystercatchers too were under little pressure to maximize the net rate of energy gain, whilst foraging, in the conditions in which observations were made.

Although Oystercatchers appeared to select mussels which maximized the net rate of energy gain, they may have done so because they were selecting to maximize intake of some other nutrient (e.g. protein) but the predicted diets were indistinguishable. Alternatively, there may have been a selective disadvantage to foraging at night. Oystercatchers foraging to maximize net energy intake during the day would thus spend less time exposed to the disadvantage at night than less efficient foragers.

A possible disadvantage of night foraging is an inability to detect and evade nocturnal predators, e.g. Foxes (Vulpes vulpes). Rates of nocturnal and diurnal predation are unknown. There is no a priori reason, however, to believe nocturnal predation is greater in the Oystercatcher than the Redshank. Redshank foraging at Culross did not

appear to maximize the rate of net energy intake, despite the fact they could not achieve positive daily energy balances by daylight feeding only, and presumably also fed at night (above).

Calculations which suggest both Redshank and Oystercatcher are able to achieve 24 h energy balances by foraging for less than 50% of the available time conflict with the widely held opinion that Winter is a time when most birds struggle to find enough food (see for example Spencer 1981). This view probably originated in energy requirement studies performed by Gibb (1956, 1960) who estimated Rock pipits (Anthus spinaletta), which feed on the coast and tits (Parus sp.) and Goldcrests (Regulus regulus) feeding in pine woods (Pinus sp.) require to find one food item every two or three seconds to survive. These estimates were reinforced more recently by similar calculations that Pied Wagtails (Motacilla alba) require to find an insect every four seconds to survive (Davies 1982). Although in both cases estimates of daily energy requirements are only inferred and may be in error, such errors are unlikely to explain all the discrepancy between the required foraging times in these previous studies (all the available time) and the current study (less than 50% of the available time).

The discrepancy is also not a result of differences in the ability to forage at night. Whilst Oystercatcher and Redshank at Culross were unable to achieve positive energy balances in most conditions by daylight feeding only, this was only because the available feeding time in daylight was short, and less than 50% of the total daylight hours. Differences in ability to achieve 24 h energy balances reflect differences in body mass between the study species. The species in this study were between 5 and 50x heavier than the species in earlier studies. Larger birds are able to collect more energy (Bryant and

Westerterp 1980) but expend relatively less energy than small birds (Walsberg 1983) this presumably favours large birds in Winter.

Differences in ability to achieve energy balances in Winter between large and small birds probably explain why of the 154 bird species regularly breeding in Britain, the 45 species which migrate totally out of Britain in Winter are significantly smaller than the 109 species which remain (Appendix 3 - \bar{x} length of residents = 36.1 cm, \bar{x} length of migrants = 22.1 cm $t = 2.98$) - lengths and status from Bruun and Singer 1979).

Since Oystercatcher and Redshank were generally quite able to achieve positive 24 h energy balances in most conditions, it would be expected mortality in Winter, as an ultimate result of starvation, would be relatively rare. It is anomalous therefore that there are many reports of heavy Winter mortality, resulting from starvation, for both species (Dobinson and Richards 1964, Goss Custard et al 1977a, Baillie 1980, Pilcher 1964, Pilcher et al. 1974, Bryant et al. 1980, Hopleston 1971, Swennen and Duiven 1982). Large mortality in severe weather is probably over publicized. More widespread (Clark 1982) or more long term studies (Goss Custard et al. 1981) reveal heavy mortality occurs only in restricted areas and is uncommon in most winters. Such mortality data would be expected from the data in this study, since conditions in which Redshank and Oystercatcher fail to achieve positive energy balances by foraging for the whole available period are very severe (less than about -4°C and -12°C respectively). Prolonged conditions more severe than this are both rare and local within Britain and the coast of Western Europe.

Whether the high probability of achieving a positive energy balance, and hence the generally high survival of wading birds in Winter (loc. cit.) means wading bird populations are limited on the breeding grounds (Hale 1980, Goss Custard et al 1982) is unknown. Populations may be

limited by occasional but severe density independent mortality (Andrewartha and Birch 1957) such as probably occurs on the wintering grounds. Clearly more research is required to investigate the energy demands of reproduction, birds abilities to meet these demands on the breeding grounds and the importance of mortality during migration.

Summary

The searching behaviour of both Redshank and Oystercatcher was consistent with a model of maximization of velocity, with acceleration limitation. The diet choice behaviour of both species was not consistent with the predictions of a model based on maximization of net energy gain. In Redshank, maximization of protein gain predictions fitted the observed data better in three of four seasons. In 'hammering' Oystercatchers a trade off with the risks of bill damage was suspected. Deviations within prizing Oystercatchers probably reflected inaccuracy in the measurement of unsuccessful attack rates, and consequent inaccurate predictions. Prizing Oystercatchers possibly do select prey which maximize net energy gain, but predictions were indistinguishable from predictions of gross energy or protein maximization, and a functional interpretation is not justified.

In general these data do not support the hypothesis that maximization of net energy gain when foraging, is necessarily commensurable with fitness. This hypothesis was suggested implicitly in the first foraging models (MacArthur and Pianka 1966, Emlen 1966) and explicitly by Schoener (1971). Maximization of net energy gain in Redshank and Oystercatcher was relatively unimportant because in most Winter conditions both species were able to achieve positive energy balances by foraging for less than 50% of the available time. Throughout Early Winter therefore, the birds are able to build up an

energy store (Minton 1975, Bronson 1975, Pienkowski et al 1979, Pinkowski 1979, Symonds 1980, Smit and Wolf 1981, Davidson 1982, Dugan et al 1983) Hence occasional periods of severe weather in Late Winter when birds cannot achieve positive energy balances, by foraging for the entire available period, have a relatively small effect on mortality because energy deficits may be supplied from this store (Grubb 1978, Dugan et al. 1981).

These data are comparable with other field studies of foraging behaviour, where it has been generally found the simple maximization of net energy gain model is insufficient to account for all the observed foraging behaviour (see Introduction, page 6, for references). In contrast with earlier laboratory studies (see Introduction, page 6, for references), where the predictions of the net energy gain model were generally upheld. This dichotomy appears to be a result of the experimental procedures involved in the laboratory studies, where conflicting selective pressures are avoided and animals are starved "...to encourage the birds to feed efficiently" (Krebs 1977 p.32).

Although laboratory studies may provide a more controlled environment, it is precisely for the same reasons these studies generate ecologically less important data.

Unfortunately, field studies are less easily performed and consequently less common. It is not possible therefore to generalize about the importance of different types of optimization functions, e.g. predator avoidance (Mittlebach 1981) territoriality (Houston and Davies 1979), nutrient intake (Belovsky 1978, Freare et al. 1974) and self injury (Bertram 1978). Temporal changes in the optimal function which maximizes fitness are probably common. The implied ability of captive predators to recognize the 'foraging problem' in the laboratory (starvation with no conflicts) and behave accordingly is perhaps evidence

that predators are able to modify their behaviour as the optimal solution maximizing fitness changes.

The implications of such temporal changes in foraging behaviour for the structure of communities is potentially large. By alternating the diet between competitive prey, predators may allow coexistence of animals which would otherwise exclude each other. This provides a more subtle influence on diversity than the 'functional link' detailed by Paine (1980) where a predator simply suppresses a single dominant prey type. Future work might investigate the importance of different types of optimal function in different types of animal. For example, is maximization of net energy gain more important in small animals?, is avoidance of being eaten oneself only a problem for small predators? and is self injury only important when attacking relatively large prey? Answers to problems of this type might allow a more general application of the results of foraging investigations to the prediction of population and community interactions.

REFERENCES

- ANDERSON, S S (1972) The ecology of Morecambe Bay II. Intertidal invertebrates and factors influencing their distribution
J.Appl ecol , 9, 161-178
- ANSELL, A D. and TREVALLIION, A (1967) Studies of *Tellina tenuis* Da Costa I. Seasonal growth and biochemical cycle
J.Exp Mar.Biol Ecol , 1, 220-235
- ASHCHOFF, J and POHL, H., (1971). Rhythmic variation in energy metabolism. Fedn Proc , 29, 1541-1552
- ASHCHOFF, J (1981). Thermal conductance in mammals land birds its dependence on body size and circadian phase. Comp.Biochem.Physiol., 69A, 611-619
- AUSTIN, G.T. (1978) Daily time budget of the post nesting Verdin Auk, 95(2), 247-252
- AVERY, M.A (1983) The timing of emergence of wintering pipistrelle bats. Unpub PhD Thesis University of Aberdeen.
- BAILLIE, S. (1980). The effect of the hard winter of 1978/79 on the wader populations of the Ythan estuary. Wader Study Group Bulletin, 28, 16-17
- BAIRD, R.H. (1966) Factors affecting the growth and condition of mussels (*Mytilus edulis*). Fishery investigations M.A F F., London Ser., 11, 25 1-33
- BAIRD, R H and DRINNAN, R.E. (1957). The ratio of shell to meat in Mytilus J Cons perm.int Explor Mer , 22 No 5
- BARNARD, C.J. and BROWN C.A J (1981) Prey size selection and competition in the common shrew (*Sorex araneua* L.). Behav Ecol Sociobiol , 8, 239-243
- BARNARD, C.J , and STEPHENS, H (1981) Prey size selection by Lapwings (*Vanellus vanellus*) in Lapwing/Gull (*Larus ridibundus*) associations Behaviour, 77, 1-22
- BARNES, R S K. (1981) Behavioural activities and ecological strategies in the intertidal gastropod (*Hydrobia ulvae*) In 'Jones, N.V. and Wolff, W J (eds) Feeding and survival strategies in estuarine organisms' Marine Science vol 15, Plenum, New York.
- BARNES, R S and HUGHES, R N (1982) An introduction to Marine ecology (Eds) Blackwell Scientific Publications, Oxford. 320p
- BAYNE, B L (1976) (Ed) Marine mussels their ecology and physiology I B P Handbook 10 Cambridge University Press

- BEANLAND, R L. (1940) Sand and mud communities on the Dovey estuary
J Mar.Biol Ass., 24, 589-611.
- BELOVSKY, G.E (1978) Diet optimization in a generalist herbivore, the
Moose Theor Popul.Biol , 14, 105-134.
- BERTRAM, (1978) 'Social organization' Chpt 3 In 'Krebs, J R. and
Davis, N B. (Eds) (1978) 'Behavioural ecology, an evolutionary
approach' Blackwell Scientific publ Oxford
- BEST, L S and BIERZCHUDCK, P (1982) Pollinator foraging in foxglove
(Digitalis pupurea) a test of a new model. Evolution, 36, 70-79
- BEUKEMA, J J (1968) Predation by the three-spined stickleback
(Gasterosteus aculeatus L.) The influence of hunger and
experience. Behaviour, 31, 1-126
- BEUKEMA, J.J. and de BUIN, W. (1977) Seasonal changes in dry weight
and chemical composition of the soft parts of the tellinid bivalve
Macoma balthica in the Dutch Wadden Sea Neth J Sea Res , 11(1),
42-55.
- BOUVEROT, P., HILDWEIN, G AND OULHEN, P (1976). Ventilatory and
circulatory O₂ convection at 4000m in pigeon at neutral or cold
temperature Resp physiol , 28(3), 371-387
- BOWEN-COLTHURST, E. (1980) Some aspects of the ecology of Mytilus
edulis L. in the Forth estuary Unpub Hons. Thesis, University of
Stirling
- BRACKENBURY, J H and AVERY, P (1980) Energy consumption and
ventilatory mechanisms in the exercising fowl
Comp Biochem.Physiol , 66A(3), 439-447.
- BRANSON, N J B A. (1976) Moults measurements and migrations of the
grey plover Bird Study, 23, 257-266
- BRODY, S (1945). Bioenergetics and Growth. New York. Rheinhold
publ corp 1023pp
- BRUNN, B and SINGER, A. (1979) Hamlyn guide to the birds of Britain
and Europe Hamlyn, London
- BRYANT, D M. (1978). Survey of shorebird feeding distribution and
movements in the Forth estuary (January) Report to N C C., Stirling
University.
- BRYANT, D M (1979) Effects of prey density and sire character on
estuary usage by overwintering waders (Charadrii) Est. and Coast
Mar Sci , 9, 369-384
- BRYANT, D M (1980) A report on the bird fauna of the Forth estuary
mudflats (Jan.-Feb) Report to N C C., R S P.B , Computer
Supplies Co , University of Stirling
- BRYANT, D M and LENG, J (1975) Feeding behaviour and distribution of
shelduck in relation to food supply Wildfowl, 26, 20-30

- BRYANT, D M. and WESTERTERP, K.R. (1980) Energetics of foraging and free existence in birds Proc Int.Orn Cong Berl. XVII, vol I, 292-299
- BUTLER, P.J. (1970) The effect of progressive hypoxia on the respiratory and cardiovascular systems of the pigeon and duck. J Physiol. (Lond), 201, 527-538
- BUTLER, P.J., WEST, N H and JONES, D.R. (1977). Respiratory and cardiovascular responses of the pigeon to sustained level flight in a wind tunnel. J Exp Biol , 71, 7-26
- BUTLER, P J and WOAKES, A J (1979). Changes in heart rate and respiratory frequency during natural behaviour of ducks with particular reference to diving. J Exp Biol., 79, 283-300.
- CADDY, J F. (1967). Maturation of gametes and spawning in Macoma balthica (L.) Can J Zool , 45(6), 955-965
- CALDER, W.A. and KING, J R (1974). Thermal and caloric relations of birds. In Farner, D , and King, J.R., (eds.). Avian Biology vol.4, 259-413 Academic Press, New York.
- CARPENTER, T M (1937). The composition of the atmosphere J Amer.Chem.Soc., 59, 358.
- CAVAGNA, G.A., SAIBENE, F.P. and MARGARIA, R. (1963). Mechanical work in running. J.Appl.Physiol., 19(20), 249-256.
- CEDERWALL, H. (1977). Annual macrofauna production of a soft bottom in the North Baltic proper. Proc 11th European Mar.Biol.Symp. (1976), 155-164
- CERRETELLI, P., PIPER, J., MONGILLI, F , and RICCI, B. (1964). Anerobic and aerobic metabolism in exercising dogs. J.Appl.Physiol., 19, 25-28
- CHANT, D A. and TURNBULL, A L. (1966). Effects of predator and prey densities on interactions between Goldfish and Daphnia pulex (De Geer) Can.J Zool , 44, 285-289
- CHAMBERS, M R. and MILNE, H (1975b) Life cycle and production of Nereis diversicolor (O F. Muller) in the Ythan estuary (Scotland). Est.Co Mar Sci , 3, 133-144
- CHAMBERS, M R and MILNE, H. (1979). Seasonal variation in the condition of some intertidal invertebrates of the Ythan estuary, Scotland. Est Co Mar Sci , 8, 411-419.
- CHAPMAN, M A G (1949) The thixotropy and dilitancy of marine soil. J Mar Biol Ass (UK), 28, 123-140
- CHAPPELL, M A (1980) Thermal energetics of chicks of arctic breeding shorebirds. Comp Biochem Physiol., 65A, 311-317
- CHARNOV, E L (1976) Optimal foraging attack strategy of the mantid Am Nat , 110, 141-151

- CLARK, B (1962) Balanced polymorphism and the diversity of sympatric species In 'Taxonomy and Geography' (Nichols, D , Ed) pp 47-70 Systematics Association, Oxford.
- CLARK, N.A. (1982) The effects of severe weather in December 1981 and in January 1982 on waders in Britain Bull Wader study grp , 34, 5-7
- CLARK, J and MCNIEL ALEXANDER, R (1975) The mechanics of running in Quail (Coturnix coturnix) J.Expt Biol., 88-113
- CLARK, R.B and HALDERLIE, E C (1960) The distribution of Nephtys cirrosa and Nephtys hombergii on the South Western coasts of England and Wales. J Anim Ecol , 29, 117-142
- CLAY, E (1960a) Literature survey of the common fauna of estuaries No 8 Hydrobia ulvae (Pennant), H ventrosta (Montagu) and Potamopyrgus jenkinsi (Smith) Paints Div., Brixham Research Station, 26pp
- CLAY, E. (1960b) Literature survey of the common fauna of estuaries No 15. Corophium volutator (Pallas) I.C.I. Paints Division, Brixham, Devon.
- COOK, R M. and COCKRELL, B.J (1978) Predator ingestion rate and its bearing on feeding time and the theory of optimal diets. J.Anim.Ecol., 47(2), 529-549
- COWIE, R.J. (1977) Optimal foraging in Great tits (Parus major). Nature, 268, 137-139
- CRAMPTON, E W and LLOYD, L.E (1959). Fundamentals of nutrition, San Francisco, Freeman
- CRISP, D.J (1971). Energy flow measurements In Methods for the study of marine benthos. Eds N A. Holme and A.D. McIntyre. Handbook No 16 Blackwell Scientific Publications.
- CUSTER, T W. and PITELKA, F A (1972). Time activity budgets and energy budgets of nesting lapland longspurs near Barrow, Alaska Proc. 1972 Tundra Biorne Symp. Lake Wilderness, University, Washington, pp. 160-164,
- DALES, R.P (1950) The reproduction and larval ldevelopment of Nereis diversicolor (O.F Muller) J Mar Biol Ass U.K 29, 231
- DARE, P J and EDWARDS, D B (1967) Seasonal changes in the flesh weight and biochemical content of mussels (Mytilus edulis) in the Conway estuary, North Wales Fishery Invest. London, (Sec II), 22, 1-15.
- DARE, P J and MERCER, A.J (1975) Foods of the Oystercatcher in Morecambe bay, Lancashire Bird Study, 20, 173-184
- DAVIDSON, N C. (1981) Survival of shorebirds (Charadrii) during severe weather the role of nutritional reserves, pp 231-249. In Jones, N V and Wolff, W J (Eds) Feeding and survival strategies of estuarine organisms Marine Science, vol 15 Plenum, New York

- DAVIDSON, N C. (1982) Changes in the body conditions of Redshanks during mild winters an inability to regulate reserves Ringing and Migration, 4, 51-62
- DAVIDSON, N C. and EVANS, P R (1981) Mortality of Redshanks and Oystercatchers from starvation during severe weather. Bird Study, 29(3), 183-189
- DAVIES, N B. (1977) Prey selection and social behaviour in Wagtails (motacillidae) J Anim Ecol., 46, 37-57
- DAVIES, N B. and HOUSTON, A I (1981) Owners and satellites the economics of territory defence in the pied Wagtail (Motacilla alba) J. Anim Ecol , 50, 157-180
- DAWKINS, M (1971a). Perceptual changes in chicks, a new look at the 'search image' concept An. Behav. (1971), 19, 566-574
- DAWKINS, M. (1971b) Shifts of attention of chicks during feeding. An. Ben., 19, 575-582
- DE BENEDICTIS, P A., GILL, F B , HAINSWORTH, F R., PYKE, G H. and WOLFF, L.L. (1978) Optimal meal size in hummingbirds. Am Nat., 112, 301-316.
- DOBINSON, H M and RICHARDS, A J (1964) The effects of the severe winter of 1962/63 on birds in Britain. Brit Birds, 57, 373-433
- DODD, A.P. (1959) The biological control of the prickly pear in Australia In 'Biogeography and Ecology in Australia', Keast, A , Crocker, R.L. AND Christian, C S (Eds) Monagr Biol., Vol 8.
- DRENT, R H. and DAAN, S (1980). The prudent parent Energetic adjustments in avian breeding Ardea (1980), 68, 225-252
- DUFFES, J (1973) Some effects of salinity on Nephtys hombergii Lamark (Annelida polychaeta). Unpub BSc Hons thesis. University of Stirling
- DUFFY, D C., ATKINS, N and SCHNEIDER, D C. (1981) Do shorebirds compete on their wintering grounds? Auk, 98(2), 215-229
- DUGAN, P.J , EVANS, P R , GOODYER, L R. and DAVIDSON, N C (1981) Winter fat reserves in shorebirds disturbance of regulated levels by severe weather conditions Ibis, 23(3), 359-364
- DUNCAN, I J H and FILSHIE, J.H. (1979). The use of radio-telemetry devices to measure temperature and energy expenditure in the Domestic Fowl In 'Amloner, C J and McDonald, D W (Eds), A handbook of biotelemetry and radio tracking' Pergamon, London
- DUNN, E K (1972) Effect of age on fishing ability of sandwich terns (Sterna sandvicensis) Ibis, 114, 360-366.
- DUNSTONE, N. and O'CONNER, R J (1979) Optimal foraging in an amphibious mammal Mustela vison l The aqualung effect Anim Behav , 27, 1182-1194

- DWYER, T J. (1975) Time budget of breeding Gadwalls Wilson Bull ,
87(3), 335-344.
- EADES, R A. and OKILL, D J (1977) Weight changes of Dunlins on the
Dee estuary in May. Bird Study, 24, 62-63
- EBERSOLE, J P and WILSON, J C (1980) Optimal foraging the response
of Peromyscus leucopus to experimental changes in processing time and
hunger. Oecologia (Berl), 46, 80-85
- EDIN, H. (1926). cited in Kleiber, M. (1967)
- ELLIOTT, C.C.H , WALTNER, M., UNDERHILL, C.G , PRINGLE, J.S S. and
DICK, W.J.A. (1976) The migration system of the Curlew Sandpiper
(Calidris ferruginea) in Africa Ostrich, 47, 191-213.
- ELLIOTT, M. (1979) Studies of the production ecology of several
mollusc species in the estuarine Firth of Forth, Vol I and II.
Unpubl PhD Thesis, University of Stirling
- ELNER, R W. and HUGHES, R.N (1978). Energy maximization in the diet of
the shore crab Carcinus meanas (L.) J.Anim Ecol., 47, 103-116.
- EMLLEN, J.M. (1966). The role of time and energy in food preference.
Am Nat., 100, 611-617.
- EMLLEN, J M. and EMLLEN, M G R. (1975) Optimal choice in diet test of
an hypothesis. Am.Nat., 109, 427-435.
- ENS, B.J. (1982) Size selection in mussel feeding Oystercatchers
Bull.wader study grp., 34, 16-20
- ERICHSON, J T., KREBS, J.R. and HOUSTON, A I (1980) Optimal foraging
and cryptic prey. J Anim Ecol., 49, 271-276
- ESTABROOK, G F. and DUNHAM, A E. (1976) Optimal diet as a function of
absolute abundance, relative abundance and relative value of available
prey Am Nat., 110, 401-413
- ETTINGER, A O and KING, J.R (1980) Time and energy budgets of the
Willow Flycatcher (Empidonax traillii) during the breeding season.
Auk, 97, 535-546
- EVANS, P R. (1976) Energy balance and optimal foraging strategies in
shorebirds some implications for their distributions and movements
in the non-breeding season Ardea, 64, 117-139
- EVANS, P R. (1977) Notes on the feeding of waders on Heron island
Sunbird, 6, 25-30.
- EVANS, P R (1979) Adaptions shown by foraging shorebirds to cyclical
variations in the activity and availability of their invertebrate
prey In 'Naylor, E and Hartnell, R G (Eds) Cyclic phenomena in
marine plants and animals ' Pergamon Press, London.

- EVANS, P R., HERDSON, D M., KNIGHTS, P J. AND PIENKOWSKI, M W. (1979) Short-term effects of reclamation of part of seal sands, Teesmouth, on wintering waders and Shelduck 1. Shorebird diets, invertebrate densities, and the impact of predation on the invertebrates. *Oecologia*, 41, 183-206
- EVANS, P R. and PIENKOWSKI, M W (1982) Behaviour of Shelducks (*Turdus naumanni*), does regulation occur *J Anim.Ecol.*, 51(1), 241-263
- EVANS, P.R. and SMITH, P C (1975) Studies of shorebirds at Lindesfarne, Northumberland 2 Fat and pectoral muscle las indicators of body condition in the bar-tailed godwit *Wildfowl*, 26, 64-76.
- FEARE, C.J., DUNNET, G M. and PATTERSON, I.J. (1974) Ecological studies of the rook (*Corvus frugilegus* L.) in North East Scotland food intake and feeding behaviour *J Appl Ecol.*, 11(3), 867-869
- FEDAK, M A. and SEEHERMAN (1979). Reappraisal of energetics of locomotion shows identical costs in bipeds and quadrupeds including ostrich and horse *Nature*, 282, 713-716.
- FEDAK, M.A., PINSHOW, B. and SCHMIDT-NIELSEN, K (1974). Energy cost of bipedal running. *Am J.Physiol.*, 227, 1038-1044
- FENCHEL, T., KOFOED, L.H. and LAPPALAINEN, A. (1975). Particle size selection of two deposit feeders - *Corophium volutator* and *Hydrobia ulvae*. *Mar.Biol.*, 30, 119-128.
- FENN, W O. (1930) Work against gravity and work due to velocity changes in running *Am. J Physiol.*, 93, 433-462.
- FERNS, P.N., MACALPINE-LENY, I H. and GOSS CUSTARD, J D (1979). Telemetry of heart rate as a possible measure of energy expenditure in the Redshank (*Tringa totanus*) In 'Amlaner, C.J. and MacDonald, D W. (1979) (Eds) A handbook of biotelemetry and radiotracking'. Pergamon Press, Oxford
- FLYNN, R.K. and GESSEMAN, J A (1973) An evaluation of heart rate as a measure of daily metabolism in pigeons (*Columba livia*) *Comp Biochem.Physiol* , 63A, 511-514.
- FRAENKEL, G S and GUNN D L. (1940) The orientation of animals Kineses, Taxes and Compass Reactions Oxford
- GABBOTT, P S and BAYNE, B L. (1973) In Bayne, B L. (Ed.) Marine mussels their ecology and physiology I B P. Handbook 10. Cambridge University Press
- GARDNER, M.B. (1981) Mechanisms of size selectivity by planktivorous fish a test of hypotheses *Ecology*, 62, 571-578.
- GENDRON, R P and STADDON, J E R. (1983) Searching for cryptic prey, the effect of search rate. *Am Nat* , 121(2), 172-186
- GERRAD, B M (1967) Factors affecting earthworms in pastures *J Anim Ecol.*, 36, 235-252

- GESSEMAN, J.A. (1973) Ecological energetics of homeotherms, a view compatible with ecological model. Utah State Univ. Press, Logan.
- GIBB, J.E. (1954) The feeding ecology of British titmice with notes on the treecreeper and goldcrest *Ibis*, 96, 513-546
- GIBB, J. (1956) Food, feeding habits and territory of the Rock Pipit (*Anthus spinoletta*) *Ibis*, 98, 506-530
- GIBB, J E. (1957). Food requirements and other observations of captive tits *Bird Study*, 4, 207-215.
- GIBSON, P. (1980) The control of handling time and its effects on the foraging strategy of a heteropteran predator, *Notonecta* *J Anim Ecol.*, 49, 699-712.
- GIRALDEAU, L A and KRAMER, D.L. (1982) The marginal valve theorem a quantitative test using load size variation in a central place forager *An Behav.*
- GLUTZ, V B (1977). *Hanbuch der Vogel Mitdeuropas Vol.7, Weisbaden.*
- GOLDSTEIN, D L. (1983) The effect of wind on avian metabolic rate with particular reference to gambels quail. *Physiological Zoology*, 56 (4), 485-493
- GOSS CUSTARD, J.D. (1969) The winter feeding ecology of the Redshank (*Tringa totanus* L). *Ibis*, 111, 338-356.
- GOSS CUSTARD, J D (1973) Current problems in studying the feeding ecology of estuarine birds. Coastal ecology research paper No. 4. N C C
- GOSS CUSTARD, J.D (1976). Variation in the dispersion of Redshank (*Tringa totanus*) on their winter feeding grounds *Ibis*, 118, 257-263
- GOSS CUSTARD, J.D. (1977a) Optimal foraging and the size selection of worms by Redshank (*Tringa totanus* L) in the field. *Anim. Behav.*, 25, 10-29.
- GOSS CUSTARD, J.D (1977b) The energetics of prey selection by Redshank (*Tringa totanus* L.), in relation to prey density. *J.Anim.Ecol.* 46, 1-19
- GOSS CUSTARD, J D. (1977c). Predator responses and prey mortality in the Redshank (*Tringa totanus* L) and a preferred prey, *Corophium volutator* (Pallas) *J.Anim Ecol.*, 46, 21-36
- GOSS CUSTARD, J D , DURRELL, S.E.A le V dit. and ENS, B J (1982) Individual differences in aggressiveness and food stealing among wintering Oystercatchers (*Heamatopus ostralegus*) *Anim Behav* , 30, 917-928
- GOSS CUSTARD, J D , DURRELL, S E A lev. dit , MCGRORTY, S , READING, C.J. and CLARKE, R T (1981) Factors affecting the occupation of mussel beds (*Mytillus edulis*) by Oystercatchers (*Heamatopus ostralegus*), on the Exe estuary, South Devon. In 'Jones, N.V. and Wolff, W.J (Eds.) Feeding and survival strategies of estuarine organisms' pp 217-229 Plenum Press, London.

- GOSS CUSTARD, J D , JENYON, R A., JONES, R E., NEWBURY, P E. and WILLIAMS, R le B (1977) The ecology of the wash 2 Seasonal variation in the feeding conditions of wading birds (Charadrii), J Appl Ecol , 14, 701-719.
- GOSS CUSTARD, J.D , DURRELL, S E A Le V dit , SITTERS, H.P. and SWINFEN, R. (1982) Age structure and survival of a wintering population of Oystercatchers Bird Study, 29(2), 82-99.
- GOSS CUSTARD, J.D. and JONES, R E. (1976) The diets of Curlew and Redshank. Bird Study, 23, 223-243
- GOSS CUSTARD, J D , KAY, D G. and BLINDELL, R M. (1977b). The density of migratory and overwintering Redshank and Curlew in relation to the density of their prey in South West England. Est Co.Mar.Sci., 5, 497-510
- GOSS CUSTARD, J.D., MCGRORTY, S , READING, C.J., DURRELL, S E A. le Vit (1980) Oystercatchers and mussels on the Exe estuary. Essays on the Exe estuary Devon Ass Special vol. 2, 161-185.
- GOSS CUSTARD, J D. and ROTHERY, P (1976) A method for measuring some components of foraging of certain birds in the field. Anim. Behav., 24, 545-550.
- GRAY, J S. (1976). The fauna of the polluted river Tees estuary. Est and Co Mar Sci., 4, 653-676.
- GREEN, J (1968) The biology of estuarine animals Sidgwick and Jackson, London, 401 pp.
- GREENHALGH, M.E (1975) Studies on the foods and feeding ecology of wading birds Unpubl. PhD Thesis, Liverpool Polytechnic.
- GREIG, S A , COVISON, J.C. and MONAGHAN, P. (1983). Age related differences in foraging success in the Herring Gulls (Larus argentatus), Anim.Behav., 31, 1237-1244.
- GRUBB, T C Jnr , and GREENWALD, L. (1983). Sparrows and a brushpile: foraging responses to different combinations of predation risk and energy cost An. Beh., 30(3), 637-641
- HAILS, C J. (1979). A comparison of flight energetics of hirundines and other birds. Comp Biochem Physiol., 63A, 581-585.
- HALE, W G (1980). Waders, Collins, London.
- HALL, S J., TODD, C.D and GORDON, A D (1982). The influence of ingestive conditioning on the prey species selection of Aeolida papillosa (Mollusca Nudibranchia) J.Anim Ecol , 51,(3), 907-923.
- HAMILTON, D and NASH, J K (1928) Piratical habits of Gulls. Scot Natur , 17, 26-27
- HARDMAN, J M. and TURNBULL, A L (1974) The interaction of spatial heterogeneity, predator competition and the functional response to prey density in a laboratory system of wolf spiders (Araneae Lycosidae) and fruit flies (Diptera Drosophilidae). J Anim.Ecol , 43(1), 155-172

- HART, T.J (1930) Preliminary notes on the bionomics of the Amphipod Corophium volutator (Pallas) J.Mar Biol.Ass. UK, 16, 761-789
- HASSELL, M.P and MAY, R M. (1974) Aggregation in predators and insect parasitoids and its effect on stability J.Anim Ecol., 43, 567-594.
- HEINRICH, B (1979) Resource heterogeneity and patterns of movement in foraging bumblebees. Oecologia (Berl), 40, 225-245
- HELP, C. and HERMAN, R. (1979) Production of Nereis diversicolor (O F. Muller) Polychaeta, in a shallow brackish water pond. Est Co.Mar.Sci., 8, 297-305
- HELLER, R. (1980) Optimal diet in a patchy environment. Theor popul. Biol., 17, 201-214.
- HEPPLESON, P B (1971) The feeding ecology of Oystercatchers (Haematopus ostralegus) in winter in Northern Scotland. J Anim.Ecol., 40, 651-672
- HESSER, C M., LINNORSSON, D. and BJURSTEDT, H. (1977) Cardio-respiratory and metabolic responses to positive, negative and minimum load dynamic leg exercise Resp physiol., 30(1), 51-69
- HILL, M O (1973). The intensity of spatial pattern in plant communities. J.Ecol., 61, 225-235.
- HODGES, C.M. (1981) Optimal foraging in bumblebees (Bombus appasitus) hunting by expectation. Anim Beh., 29, 1166-1171.
- HOLLING, C J. (1959). Some characteristics of simple types of predation and parasitism. Can Ent., 91, 385-398
- HOLLING, C.J (1965). Functional response of invertebrate predators to prey density. Mem.Ent.Soc Can , 48, 1-86.
- HOLMES, R.T , BLACK, C.P and SHERRY, T.W (1979). Comparative population bioenergetics of three insectivorous passerines in a deciduous forest Condor, 81(1), 9-20.
- HOUSTON, A I., KREBS, J R and ERICHSON, J T. (1980) Optimal prey choice and discrimination time in the Great Tit (Parus major). Behav Ecol. and Sociobiol , 6, 169-175.
- HUFFAKER, C.B. and KENNET, C E. (1956) Experimental studies of predation predation and cyclamen mite populations on strawberries in California Hilgardia, 26, 191-222.
- HUGHES, R.N (1979) Optimal diets under the energy maximization premise the effects of recognition time and learning Am Nat., 113, 209-222.
- HULSHER, J.B (1976). Localization of cockles (Cardium edule L.) by Oystercatcher (Heamatopus ostralegus) in darkness and daylight. Ardea, 64, 292-311

- HULSHER, J B. (1981) The Oystercatcher (Haematopus ostralegus) as a predator of the bivalve Macoma balthica, in the dutch, Wadden Sea. Ardea, 70, 89-152
- HYLLEBERG, J and GALLUCCI, V F (1975) Selectivity in feeding by deposit feeding bivalve - Macoma nasuta Mar.Biol., 32(2), 167-178.
- IRVING, L. (1956a). Physiological insulation of swine as bare-skinned animals J App.Physiol , 9, 414-420
- IRVING, L. (1956b) Metabolism and insulation of swine as bare-skinned animals. J.Appl Physiol , 9, 421-426
- JOHNSON, I (1981) Aspects of the ecology and physiology of Mytilus edulis L. in the Forth estuary in relation to vertical height on the shore. Unpub Hons thesis, University of Stirling.
- KEAST, A. and WELSH, L. (1964). Daily feeding periodicities, food uptake rates, and dietary changes with hour of day in some lake fishes. J Fish Res Board.Can., 25, 1133-1144
- KENDEIGH, S C. (1970). Energy requirements for existence in relation to size of bird Condor, 72, 60-66.
- KENDEIGH, S.C. (1977). Avian energetics. In 'Granivorous birds in Ecosystems', Vol 12 Pinowski, J. and Kendeigh, S.C , Cambridge Univ. Press.
- KERSTEN, M (1982). The combined effect of wind and radiation on the energy requirements for thermoregulation in birds. Unpub. manuscript
- KENWARD, R E. (1978) Hawks and doves: factors affecting success and selection in goshawk attacks on woodpigeons. J.Anim Ecol., 47(2), 449-461.
- KING, J R. (1974). Seasonal allocation of time and energy resources in birds In Paynter, R.A. Jr (Ed.) "Avian energetics", p 4-85. Publ Nuttal.Orn. Club. No 15
- KLIEBER, M. (1967) The fire of life Third impression. 2nd Ed John Wiley and Sons, New York, 454pp.
- KONTOGIANNIS, (1968). The effect of temperature and exercise on the body weight and energy intake of the White-throated Sparrows (Zonotrichia albicollis) Physiol Zool , 43, 54-64
- KREBS, J R. (1978) Optimal foraging decision rules for predators In Krebs, J.R and Davies, N B (Eds), Behavioural Ecology An Evolutionary approach, Chpt 2, Blackwell Scientific Publications, Oxford
- KREBS, J R ERICHSEN, J T , WEBBER, M I and CHARNOV, E L. (1977) Optimal prey selection in the Great Tit (Parus major) Anim Behav., 25, 30-38
- KREBS, J R., KACELNIK, A. and TAYLOR, P (1978). Test of optimal sampling in the Great Tit Nature Lond, 275, 27-31

- KREBS, J R., RYAN, J C and CHARNOV, E.L. (1974). Hunting by expectation or optimal foraging a study of patch use in chickadees. *Anim.Behav.*, 22, 953-964
- KREBS, J R., STEPEHNS, D W and SUTHERLAND, W J (1983). Perspectives in optimal foraging In Clark, G A (Ed) Perspectives in ornithology Cambridge University Press
- KRUGER, K., PRINZINGER, R. and SCHUCHMANN, K.L. (1980) Torpor and metabolism in hummingbirds *Comp.Biochem and Physiol.*, 73A, 679-689
- KUSHLAN, J.A. (1977). Population energetics of the American White Ibis. *Auk*, 94, 114-122.
- LACK, D. (1954) The natural regulation of animal numbers. Oxford.
- LACK, D. (1971) Ecological isolation in birds. Blackwell Scientific Publications, Oxford
- LALLY, D A., ZECHMANN, F W. and TRACY, R A. (1974). Ventilatory responses to exercise in divers and non divers. *Resp.Physiol.*, 20(2), 117-131
- LAMMENS, J J. (1967) Growth and reproduction in a tidal flat population of Macoma balthica (L.). *Neth.J Sea Res.*, 3, 315-382.
- LASIEWISKI, R.C. and DAWSON, W R. (1968) A re-examination of the relation between standard metabolic rate and body weight in birds. *Condor*, 69, 13-23.
- LAWRENCE, D H. and MASON, W A. (1955) Intake and weight adjustment in rats to changes in the feeding schedule *J.Comp.Physiol Psychol.*, 48, 43-46
- LAWTON, J H , BEDDINGTON, J R and BONSER, R (1974). Switching in invertebrate predators. In Usher, M.B. and Williamson, M.H., *Ecological stability*. Chapman and Hall, London.
- LENT, C M. (1968) Air gaping by the ribbed mussel (Modiolus demissus) (Dillwyn) Effects and adaptive significance *Biol Bull.Mar Biol.Lab Woods Hole, Mass.*, 134, 60-73
- LINKE, O (1939). Die Biota des Jadebusenwattes Helgolonde wiss Meeresunters, Bd 1, 201-348.
- LISSAMAN, P B S. and SCHOLLENBERGER, C A. (1970) Formation flight of birds. *Science*, 168, 1003-1005
- LITTLE, C and NIX, W (1976) The burrowing and floating behaviour of the gastropod (Hydrobia ulvae) *Est Co.Mar.Sci.*, 4, 537-544
- LUND, G F and FOLK, G.E Jr. (1976) Simultaneous measurements of heart rate and oxygen consumption in Black-tailed Prarie dogs (Gynomys ludovicianus). *Comp.Biochem Physiol* , 53A, 201-207.
- MANN, N J (1983) Comparative physiology of the Scrub Jay (Aphelocoma coerulescens) and Stellers Jay (Cyanocitta stelleri) *Comp Biochem Physiol* , 76A (2), 1983, 305-319

- MARCONI, C., PENDERGAST, D , KRASNEY, J A., RENNIE, D W., CERRETELLI, P., (1982). Dynamic and steady state metabolic changes in running dogs Resp.Physiol., 50, 93-110
- MARGARIA, R., CERRETELLI, P , AGHEMO, P. and SASSI, G (1963) Energy cost of running J Appl Physiol , 18, 367-370
- MARTEN, G (1973). An optimization equation for predation. Ecology, 54, 92-101
- MAXON, S.J. and ORING, L.W (1980) Breeding season time and energy budgets of the polyandrous spotted sandpiper Behaviour, 74, 200-263
- MAYNARD SMITH, J S (1983). Evolution and the theory of games. Cambridge University Press
- McARTHUR, R.H. (1972) Geographical Ecology. Harper and Row, New York.
- McARTHUR, R H. and PIANKA, E R. (1966) On the optimal use of a patchy environment. Am.Nat., 100, 603-609.
- McLUSKY, D S. (1968) Some effects of salinity on the distribution and abundance of Corophium volutator in the Ythan estuary. J Mar Biol.Ass.U.K., 48, 443-454
- McLUSKY, D.S (1981) Estuarine ecology Blackie, Glasgow
- McLUSKY, D S., BRYANT, D.M., ELLIOTT, M., TEARE, M and MOFFAT, G. (1976). Intertidal fauna of the polluted Forth estuary Mar.Pol.Bull., 7, 48-50.
- MEADOWS, P.S. and REID, A. (1966) The behaviour of Corophium volutator J Zool Lond , 150, 387-400.
- MINTON, K. (1979) Factors influencing leaf choice by Howler monkeys a test of some hypotheses of food selection by a generalist herbivore Am.Nat., 114, 362-368.
- MINTON, C.D T. (1975). The waders of the Wash - ringing and biometric studies Report to Wash feasibility study Water Resources Board
- MITTELBACH, G.G (1981) Foraging efficiency and body size A study of optimal diet and habitat use by Bluegills Ecology, 62(5), 1370-1386
- MONTEITH, J L. (1973) Principles of environmental physics. Edward Arnold, London
- MOOK, L J. and DAVIES, D M (1967) The European preying mantis (Mantis religiosa L.) as a predator of the red legged grass hopper (Melonoplus femurrubrum) De Geer. Can Entomol., 98, 913-918
- MORHADT, J E. and MORHADT, S S (1971) Correlation between heart rate and oxygen consumption in Rodents Am.J Physiol , 221, 1580-1586
- MORSE, D H (1980) Behavioural mechanisms in Ecology. Harvard University Press, Cambridge, Mass

- MOSS, R. (1973) The digestion and intake of foods by wild Ptarmigan in Alaska. *Condor*, 75, 293-300
- MOSS, R. (1975) The digestion of heather by Red Grouse during the Spring *Condor*, 79, 471-477
- MOSSMAN, D E. (1977) The energetics of Corophium volutator (Pallas), Unpubl. PhD thesis, University of London
- MURDOCH, W.W. and OATEN, A.S (1975) Predation and population stability *Adv Ecol Res* , 9, 2-131.
- MUUS, B J (1967) The fauna of Danish estuaries and lagoons. *Meddr. Danm., Fisk, og Havunders*, 5, 7-316
- MYREN, R T and PELLA, J J. (1977) Natural variability in the distribution of an intertidal population of Macoma balthica subject to potential oil pollution at Port Valdez, Alaska *Mar.Biol* 41, 371-382.
- NELSON, R.A., WAHNER, H W., JONES, J D , ELLEFSON, R.D. and ZOLLMAN, P.E. (1973) Metabolism of bears before, during and after Winter sleep. *Am.J Physiol.*, 224, 491-496
- NEWELL, R (1965) The role of detritus in the nutrition of two marine deposit feeders, the prosobranch Hydrobia ulvae and the bivalve Macoma balthica *Proc R.Zool.Soc.(Lond)*, 144, 25-45.
- NEWTON, I. (1980). The role of food limiting bird numbers. *Ardea*, 68(1), 11-30
- NORBERG, R.A. (1977). An ecological theory of foraging time and energetics and choice of optimal food searching method *J.Anim.Ecol.*, 46, 511-531
- NORTON GRIFFITHS, M. (1967). Some ecological aspects of the feeding behaviour of the Oystercatcher Haematopus ostralegus on the edible mussel Mytilus edulis *Ibis*, 109, 412-424.
- NORTON GRIFFITHS, M. (1968) The feeding behaviour of the Oystercatchers (Haematopus ostralegus) PhD thesis, University of Oxford.
- O'CONNOR, R J. and BROWN, R A (1977) Prey depletion and foraging strategy in the Oystercatcher (Haematopus ostralegus) *Oecologia*, 27, 75-92
- ODUM, E.P (1971) *Fundamentals of Ecology* Third edition London.
- OLLASON, J G (1980). Learning to forage optimally. *Theor.popul Biol.* 18(1) 44-56
- ORIAN, G H (1961). The ecology of Blackbird (Agelaius) social systems. *Ecol monogr* , 31, 285-312.
- ORIAN, G H (1969) Age and hunting success in the Brown Pelican (Pelecanus occidentalis) *Anim.Behav* , 17, 316-319
- OWEN, R B. (1969) Heart rate, a measure of metabolism in the Blue Winged Teal *Comp Biochem.Physiol* , 31, 431-436

- PAGE, G and WHITACRE, D F. (1975). Raptor predation on wintering shorebirds *Condor*, 77, 73-83
- PAINE, R.T. (1980) The third Tansley lecture food webs linkage, interaction strength and community structure *J Anim.Ecol.*, 49(3), 667-687.
- PASSMORE, N I and DURBIN, R A (1955) Cited in Ricklefs, R.E., Chpt. 4. In Paynter, R.A. Jr. (Ed) 'Avian energetics'. Publ.Nuttal.Ornith. Club, No. 15
- PASTORAK, R A. (1980) Selection of prey by Chaoborus larvae A review and new evidence fgor behavioural flexibility. In Kerfoot, W.C. (ed.) Evolution and ecology of Zooplankton communities. Univ. Press of New England. *Ecology*, 62(5), 1131-1324.
- PEARSON, O.P. (1950) The metabolism of Hummingbirds. *Condor*, 52, 145-152.
- PENNER, S P (1981) Factors influencing the inland feeding behaviour of estuarine wading birds on the Firth of Forth. Unpub Hons. thesis, University of Stirling
- PERNOLL, M L , METCALFE, T.L., SCHLENKER, T.L., WEKH, J.E. and MATSUMOTO, J A. (1975). Oxygen consumption at rest and during exercise in pregnancy. 25, 285-294
- PETERSON, C.H. (1979) Predation, competitive exclusion and diveristy of soft sediment benthic communities of estuaries and lagoons In Livingston, R J. (Ed.) Ecological processes in coastal and marine systems 233-264. Plenum Press, New York.
- PETTIFOR, R.A. (1983). Seasonal variation and associated energetic implications in the hunting behaviour of the Kestrel. *Bird Study*, 30, 201-206.
- PFUND, A H. AND GEMMILL, C L. (1940). An infra-red absorption method for quantitative analysis of respiratory and other gases *Bull. John Hopkins Hosp* , 67, 61-65).
- PHILLIPS, A.M. Jr., PODOLIAK, H.A , POSTON, H.A , LIVINGSTON, D.L., BROOKE, H.E., PYLE, E E and HAMMER, G.L. (1964) *Fish Res Bull* 27 In Halver, J E (Ed.) *Fish Nutrition, The Vitamins*, Ch 2. Academic, London.
- PIANKA, E.L (1966) Convexity, desert lizards and spatial hetrogeneity. *Ecology*, 47, 1055-1059)
- PIANKA, E R and PARKER, W S (1975). Age specific reproductive tactics. *Am Nat.*, 109, 453-464
- PIENKOWSKI, M W., LLOYD, C S. and MINTON, C D T (1979). Seasonal and migrational weight changes in dunlins *Bird Study*, 26(3), 134-149
- PIIPER, J (1982) Respiratory gas exchange at lungs, gills and tissues mechanisms and adjustments *J Exp Biol.*, 100, 5-22

- PILCHER, R E M. (1964) Effects of the cold weather of 1962-1963 on birds of the North coast of the Wash Wildfowl Trust Ann.Rep , 15, 23-26
- PILCHER, R E.M , BEER, J V and COOK, W A. (1974) Ten years of intensive late winter surveys for waterfowl corpses on the North West shore of the Wash, England. Wildfowl, 25, 149-154
- PRANGE, H D. and SCHMIDT NIELSEN, K (1970). The metabolic cost of swimming in ducks J Exp Biol , 53, 743-777.
- PRATER, A J. (1972). The ecology of Morecambe Bay III. Food and feeding habits of the Knot (Calidris canutus) in Morecambe Bay. J Appl.Ecol., 9, 179-194.
- PRATER, A J. (1974). The population and migration of the knot in Europe. Proc. Wader Symp Warsaw, 1973, 99-115.
- PRATER, A.J. (1974). BTO/RSPB Birds of estuaries enquiry. Report for 1972-1973. Tring British Trust of Ornithology.
- PRATER, A.J (1975). BTO/RSPB Birds of estuaries enquiry. Report for 1973-1974. Tring British Trust of Ornithology.
- PRATER, A.J , MARCHANT, J.H. and VUORINEN (1977). Guide to the identification and ageing of holarctic waders. BTO guide 17, Maud and Irving Ltd , Tring.
- PRATER, A J (1981). Estuary birds of Britain and Ireland. Poyser, Calton.
- PRICE, T.J. (1974). The organic content of shells and soft tissues of selected estuarine gastropods and pelecypods. Proc Natl. Shellfish Assn , 65, 26-31.
- PULLIAM, H R. (1974) On the theory of optimal diets. Am.Nat., 108, 59-74.
- PUTTICK, G M. (1979) Foraging behaviour and activity budgets of Curlew Sandpipers. Ardea, 67, 111-123
- PYKE, G.H., PULLIAM, H.R. and CHARNOV, E.L. (1977) Optimal foraging A selective review of theory and test. Q.Rev.Biol., 52, 137-154
- RAO, K P (1953) Rate of water propulsion in Mytilus californianus as a function of latitude. Biol.Bull Mar Biol Lab. Woods Hole, Mass., 104, 171-181.
- RAPPORT, D.J (1971) An optimization model for food selection. Am Nat , 108, 59-74.
- RAPPORT, D J (1980) Optimal foraging for complementary resources. Am Nat., 116, 324-346
- READING, C.J and McGRORTY, S (1978). Seasonal variations on the burying depth of Macoma balthica (L) and its accessibility to wading birds Est Co Mar Sci , 6, 135-144

- RECHER, H F and RECHER, J A. (1969). Comparative foraging efficiency of immature and adult Blue Herons Anim Beh., 17, 320-322.
- RECHTEN, C , AVERY, M and STEVENS, A. (1983) Optimal prey selection Why do Great Tits show partial preferences. Anim.Behav
- REES, M I (1937). Determining ash in high carbonate coals - study of the modified method. Ind Eng Chem Anal., 9, 307-309.
- RICHTER, C.P and RICE, K K. (1945) Self selection studies on coprophagy as a source of vitamin B complex. Amer.J Physiol., 143, 344-354
- RICKLEFS, R.E. (1972). Ecology Nelson, London
- RICKLEFS, R.E. (1974) Chpt. 4. In Paynter, R.A. Jr. (Ed.) 'Avian Energetics'. Publ.Nuttal Ornith Club, No. 15.
- ROBINSON, D.E , CAMPBELL, G.S. and KING, J R. (1976). An evaluation of heat exchange in small birds. J Comp.Physiol., 105, 153-166
- ROTHSCHILD, M A (1940) Rearing animals in captivity for the study of trematode life histories J Mar Biol.Assn UK, 24, 613-617.
- ROYAMA, T. (1970). Factors governing the hunting behaviour and selection of food by the Great Tit (Parus major L.). J Anim.Ecol., 39, 619-668.
- ROZIN, P and MEYER, J. (1961). Regulation of food intake in the goldfish. Am.J.Physiol , 201, 968-974.
- RYPSTRA, A.L. (1982). Building a better insect trap an experimental investigation of prey capture in a variety of spiders webs. Oecologia (Berl), 52, 31-36.
- SALONEN, K S , SARVALA, J , HAKALA, I., VILJANEN, M.J. (1977). The relation of energy and organic carbon in aquatic invertebrates. Limnol. Oceanogr , 21(5), 724-730
- SANDNESS, J N. and McMURTY, J A. (1970) Functional responses of three species of Phytoseiidae (Acorina) to prey density Can.Ent., 102, 692-704.
- SCHARTZ, R.L. and ZIMMERMAN, J L. (1971) The time and energy budget of the male dickcissel (Spiza americana) Condor, 73, 65-76.
- SCHMIDT-NIELSEN, K (1972) Locomotion energy cost of swimming flying and running Science, 177, 222-228
- SCHMIDT-NIELSEN, K. (1975) Animal Physiology adaptation and environment. Cambridge University Press. 699pp
- SCHOENER, T W. (1971) Theory of feeding strategies Ann.Rev Ecol Syst., 2, 369-404

- SCHOLANDER, P F., HOCK, R , WALTERS, V., JOHSON, F and IRVING, L. (1950).
Heat regulation in some arctic and tropical mammals and birds.
Biol Bull., 99, 237-258
- SEARCY, W.A. (1978) Foraging success in three age classes of Glaucous-winged Gulls. Auk, 95(3), 586-588.
- SEED, R. (1973). Absolute and allometric growth in the mussel (Mytilus edulis) (Mollusa bivalvia) Proc.Mal.Soc.Lond., 40, 343-357.
- SEGREM, N.P. and HART, J S. (1967) Oxygen supply and performance in Peromyscus Metabolic and circulatory responses to exercises. Can.J Physiol Pharm , 45, 543-549.
- SHILOV, I A. (1968). Heat regulation in birds. An Ecological Physiological outline Amerino Publ.Co., New York. (Translated from Russian original)
- SIH, A (1980). Optimal foraging partial consumption of prey. Am.Nat., 116(2), 281-290.
- SMIT, E L.B (1951) Animal production in the Danish Wadden Sea. Medcl Komm.Dansk.Fisk.Havunoets Ser.Fiskeri, II (6), 1-151.
- SMIT, C.J and WOLFF, W J. (1981). (Eds.) Birds of the Wadden Sea. Wadden Sea working group report No 6. A A. Balkema, Rotterdam.
- SMITH, J N.M. (1974) The food searching behaviour of two European Thrushes II. The adaptiveness of the search patterns Behaviour, 49, 1-61.
- SMITH, K.J and PRICE, (1973). Fasting metabolism of subadult Mallards. Condor, 75, 330-335
- SMITH, P C (1975) A study of winter feeding ecology and behaviour of Bar-tailed Godwit (Limosa lapponica). Unpubl. PhD thesis, University of Durham.
- SOUTHWOOD, T.R.E (1977). Habitat the templet for ecological strategies? J Anim.Ecol., 46, 337-365.
- SPEAKMAN, J.R (1980) The costs and gains of foraging in wading birds (Charadrii) Unpubl Hons thesis, University of Stirling.
- SPEAKMAN, J.R (1983). The searching behaviour of foraging Redshanks (Tringa totanus). Bull.Wader Study Grp., 37, 13-16
- SPENCER, R (1981) Birds in winter - an outline. Bird Study, 29(3), 169-182
- SPOOR, H.F (1948) Application of the Infra-red analyser to the study of Human energy metabolism J Appl.Physiol., 1, 369-384.
- STEARNS, S C. (1976). Life history tactics a review of the ideas Q Rev.Biol., 51, 3-47.
- STOPFORTH, S C. (1951). An ecological survey of the Cheshire foreshore of the Dee estuary J.Anim Ecol , 20, 103-122.

- SUTHERLAND, W J (1982b). Spatial variation in the predation of cockles by Oystercatchers at Traeth Melynog, Anglesey II. The pattern of mortality J Anim Ecol , 51, 491-500.
- SUTHERLAND, W J (1982c) Do Oystercatchers select the most profitable cockles? Anim Behav. 30(3), 850-860.
- SWENNEN, C and DUIVEN, P (1982) Characteristics of Oystercatchers killed by cold stress in the Dutch Wadden Sea area. Ardea, 71(1), 155-161.
- SYMONDS, F.L. (1980). Wader movements within and through the Firth of Forth some preliminary results Edin. Ringing Grp., Report No 7, 17-30
- SZLYK, P.C , McDONALD, B W., PENDERGAST, D R., KRASNEY, J.A. (1981). Control of ventilation during graded exercise in the dog. Respir Physiol 46(3), 193-412
- TAYLOR, C.R. (1977). The energetics of terrestrial locomotion and body size in vertebrates. In 'Scale effects in animal locomotion'. Pedley, S C., (Ed.).
- TAYLOR, C.R. (1979). In Elder and Trueman (Eds.), 'Aspects of animal movement.'
- TAYLOR, C.R. and ROWNTREE, V.J. (1973). Running on two or four legs which consumes more energy? Science, 179, 186-187.
- TAYLOR, C R., SCHMIDT-NIELSEN, K. and RAAB, J L. (1970) Scaling of energetic cost of locomotion to body size in mammals. Am.J.Physiol., 219, 1104-1107.
- TAYLOR, C R., SHTONIK, A , DMI'EL, R., BAHORAV, D. and BARUT, A. (1974). Running in cheetahs, gazelles and goats energy cost and limb configuration. Am.J.Physiol., 227, 848-850.
- THAMDRUP, H M. (1935). Beitrage zur Okologie der Wattenfauna auf experimenteller grundlage Meod Komm. Panmarks Fisk. og Havunders. Ser Fiskeri, vol X, Nr 2.
- THOMAS, S P. and STRUTHERS, R A (1972). The physiology and energetics of bat flight. J.Exp Biol., 57, 317-335.
- TIMMIN, M E. (1973) A multi-species consumption model. Math Biosci., 16, 59-66
- TINBERGEN, L (1960). The natural control of insects in pinewoods 1. Factors influencing the intensity of predation by song birds. Arch neerl.Zool , 13, 265-343
- TJALLINGII, S J (1971). Habitat selection in the Avocet (Recurvirostra quosetta) in relation to feeding. In Proc. International ornithological conference, Den Haag (1971), p 696 (Abstract only).

- TREVOR, J.H. (1977) The burrowing of Nereis diversicolor together with some notes on Arenicola marina (Annelida polychaeta) J.Exp Mar Biol Ecol , 30, 129-145
- TUCKER, V A. (1968) Respiratory exchange and evaporative water loss in the flying budgerigar J Exptl.Biol , 48, 67-87
- TUCKER, V A. (1972). Metabolism during flight of the Laughing Gull (Larus atricilla). Am.J Physiol., 222(2), 237-245
- TUNNICLIFFE, V. and RISK, M J (1977) Relationships between the bivalve Macoma balthica and bacteria in intertidal sediments. J Mar Res., 35(3), 499-407.
- TULLOCK, V.A. (1970) The Coal Tit as a careful shopper. Am.Nat., 104, 77-80.
- TURNER, A.K (1981) The use of time and energy by aerial feeding birds. Unpubl. PhD thesis, University of Stirling.
- TURNER, A.K. (1982). Optimal foraging by the Swallow (Hirundo rustica L) prey size selection. An.Beh., 30(3), 862-873
- URSIN, H., BAADE, E. and LEVINE, S (1977). Coping men - a study of human psychobiology. London Academic Press
- VADAS, R L. (1977). Preferential feeding an optimization strategy in sea urchins. Ecol.monogr., 47, 337-371.
- VADER. W.J M (1964) A preliminary investigation into the reaction of the infauna of tidal flats to tidal fluctuations in water level. Neth J Sea Research, 2, 189-222.
- VASSALLO, M.J. (1969) The ecology of Macoma inconspicua (balthica) in central San Fransisco Bay II. Stratification within the substrate The Veliger, 13(3), 279-284.
- VERBEEK, N.A.M. (1964) A time and energy budget study of the Brewer Blackbird. Condor, 66, 70-74.
- VISSER, M (1981) Prediction of switching and counter switching based on optimal foraging. Z.Tierpsychol , 55, 129-138
- VINES, G. (1980) Spatial consequences of aggressive behaviour in flocks of Oystercatchers (Heamatopus ostralegus L) Anim Beh , 28, 1175-1185
- WAKELEY, J S (1978) Energy budgets, energy expenditures and energy intakes of nesting ferruginous Hawks Auk, 95, 667-676.
- WALSBERG, G E (1978). Broad size and the use of time and energy by Phainopelma Ecology, 59(1), 147-153.
- WALSBERG, G E (1983) Avian Ecological energetics In 'Farner, D S., King, J R and Parkes, K.C (Eds). Avian Biology Vol. VII. Academic London

- WARNES, J M. (1981). The production ecology of Hydrobia ulvae and the impact of shorebirds on the Forth estuary. Unpub. thesis, University of Stirling
- WARWICK, R M and PRICE, R. (1975) Macrofauna production in an estuarine habitat. J Mar Biol.Ass , UK, 55, 1-18
- WATKIN, E.E (1941) The yearly life cycle of the Amphipod, Corophium volutator. J.Anim Ecol., 10, 77-93.
- WEINS, J.A. and INNIS, G S (1978) Estimation of energy flow in bird communities, a population bioenergetics model. Ecology, 55, 730-746.
- WERNER, E.E. and HALL, D J (1974). Optimal foraging and size selection of prey by the Bluegill Sunfish (Lepomis macrochirus). Ecology, 55, 1042-1052.
- WEST, G.C. and HART, J.S (1966) Metabolic responses of evening grosbeaks to constant and fluctuating temperatures. Physiol Zool., 39, 171-184.
- WHITE, A., HANDLER, P and SMITH, E.L (1964). Principles of Biochemistry, 3rd edn. McGraw Hill Book Co., New York, 1106pp
- WHITLOCK, R J. (1979) The ecological significance of energy conservation during roosting for wading birds. Unpubl. Hons. thesis, University of Stirling.
- WILSON, J H. (1971). A study of feeding growth and reproduction of Mytilus edulis in Carungford Lough. Unpubl. PhD thesis, The Queens University, Belfast, N Ireland.
- WINBERG, G C. (1971). Methods for the estimation of the production of aquatic animals. Academic, London, 175pp.
- WITHERBY, H.F., JOURDAIN, F C.R., TICEHURST, N.F. and TUCKER, B W. (1940). Handbook of British Birds, London
- WOAKES, A J and BUTLER, P J. (1983) Swimming and diving in Tufted Ducks (Aythya fuligula) with particular reference to heart rate and gas exchange. J.Exp Biol., 107, 311-329
- WOLF, L.L. (1975). Energy intake and expenditure in a nectar feeding sunbird Ecology, 56(1), 92-104.
- WOLF, L.L. and HAINSWORTH, F R. (1971). Time and energy budgets of territorial hummingbirds Ecology, 52, 980-988
- WOLFF, W J. (1969) Distribution of non-breeding waders in an estuarine area in relation to the distribution of their food organisms. Ardea, 57, 1-28.
- WOLFF, W J. (1973) Changes in intertidal benthos communities after an increase in salinity. Thalassis jugosl., 7, 429-434.
- WOOLEY, J B and OWEN, R B (1978). Energy costs of activity and daily energy expenditure in the Black Duck J Wildl Monag., 42(4), 739-745.

- YONGE, C M. (1949) On the structure and adaptations of the Tellinacea, deposit feeding Eulamellibranchia Phil Trans.R.Soc Ser B , Vol. 234, p 26-76
- ZACH, R. (1979) Shell dropping, decision making and optimal foraging in north-western crows Behaviour, 68, 106-117
- ZWARTS, L. (1974). Density related processes in the feeding dispersion and feeding activity of Teal (Anas crecca) Ardea, 64, 192-209.
- ZWARTS, L. and DRENT, R. (1981) Prey depletion and the regulation of predator density Oystercatchers (Haematopus ostralegus) feeding on mussels (Mytilus edulis). In Feeding and survival strategies of estuarine organisms. Jones, N.V. and Wolff, W.J. (Eds.), pp 193-216 Plenum Press, London.

Appendix 1

Definition of measurements made on invertebrates

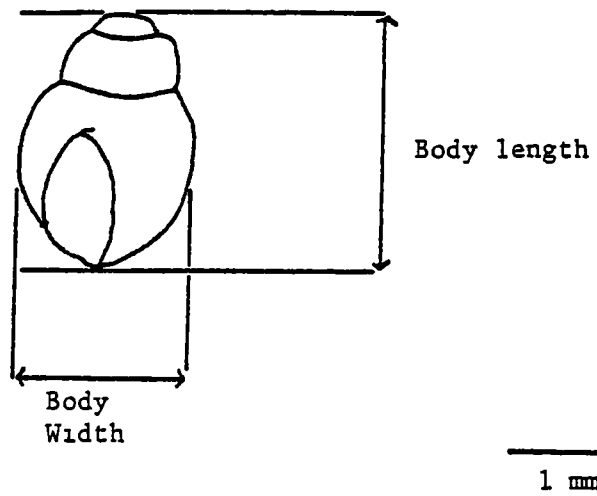
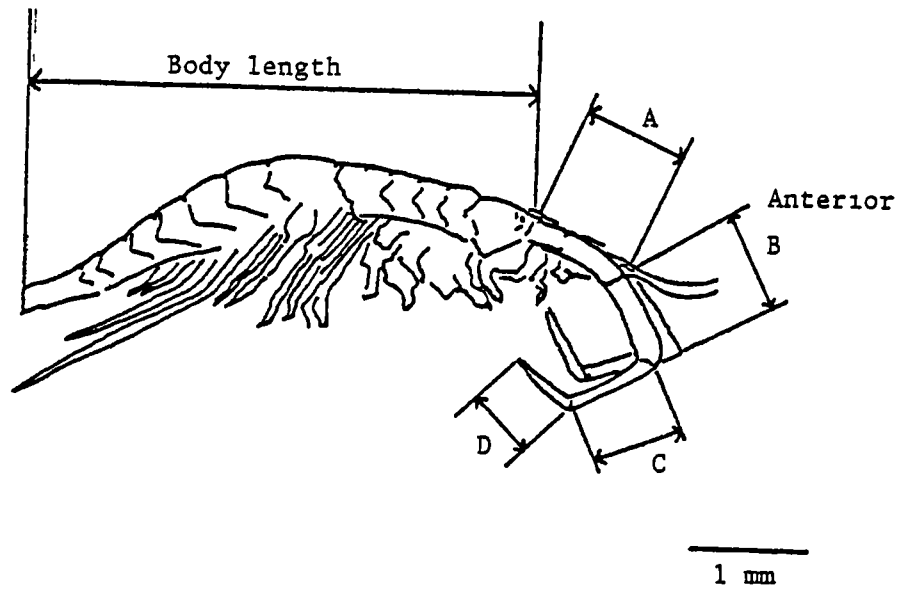
(a) *Hydrobia ulvae* (lateral view)(b) *Corophium volutator* (lateral view)

Length of second antennae = $A + B + C + D$

Length of protopodite of second antennae = D

Appendix 1 (contd)

(c) *Macoma balthica*

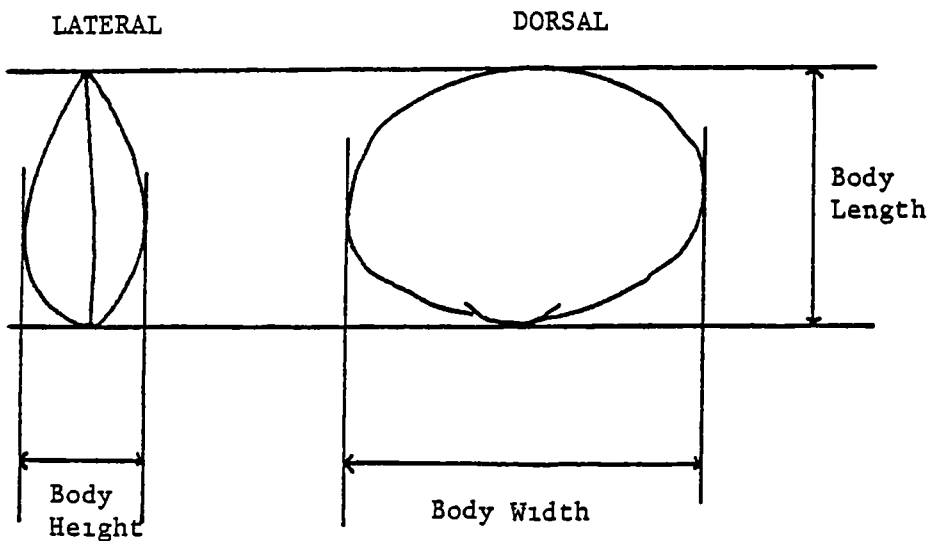

(d) *Nereis diversicolor* (*Nepthys hombergii*) DORSAL

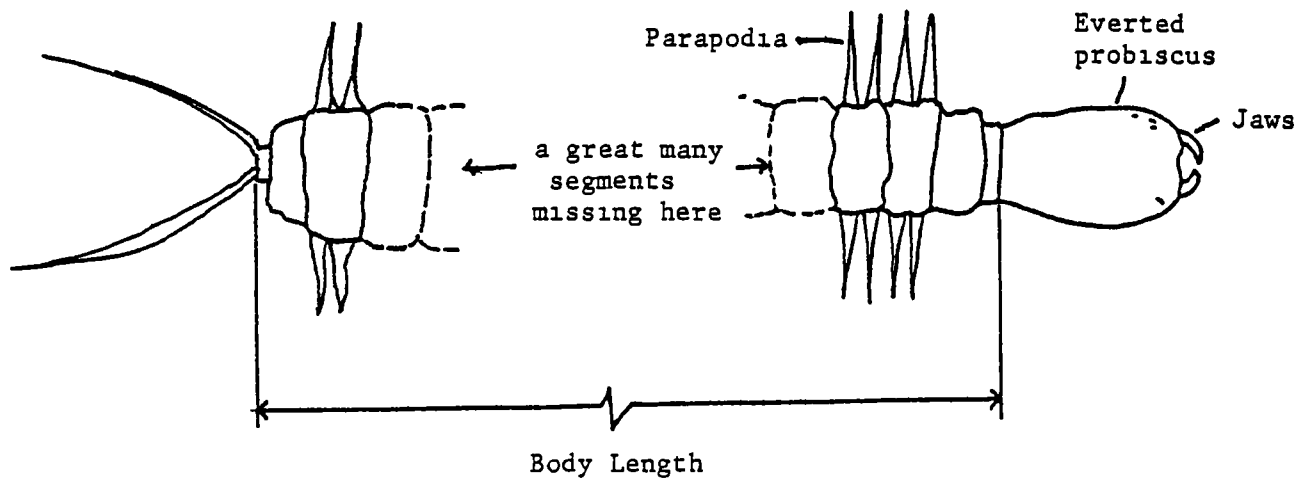

Body width includes parapodia

Appendix 1 (contd)

(c) *Mytilus edulis*

(1) external characters

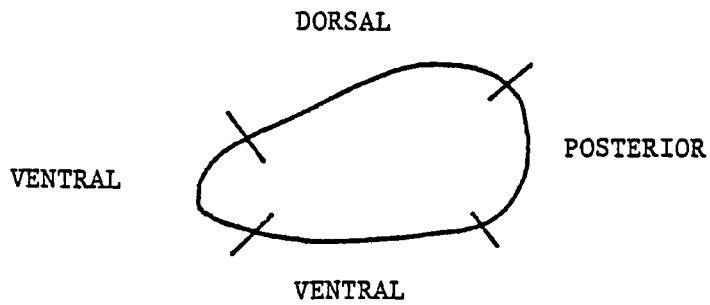
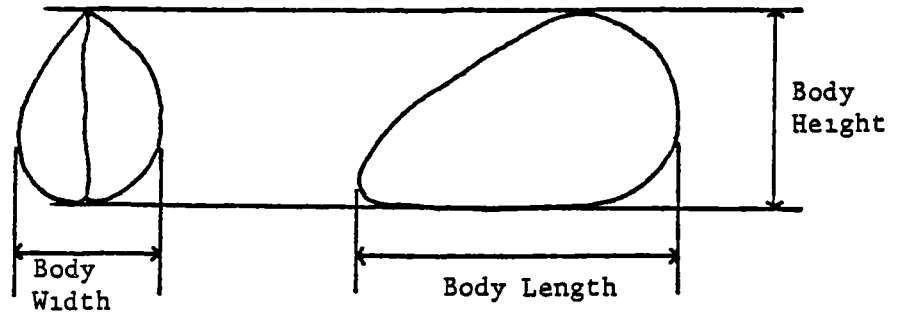

(11) internal characters (muscle scar)

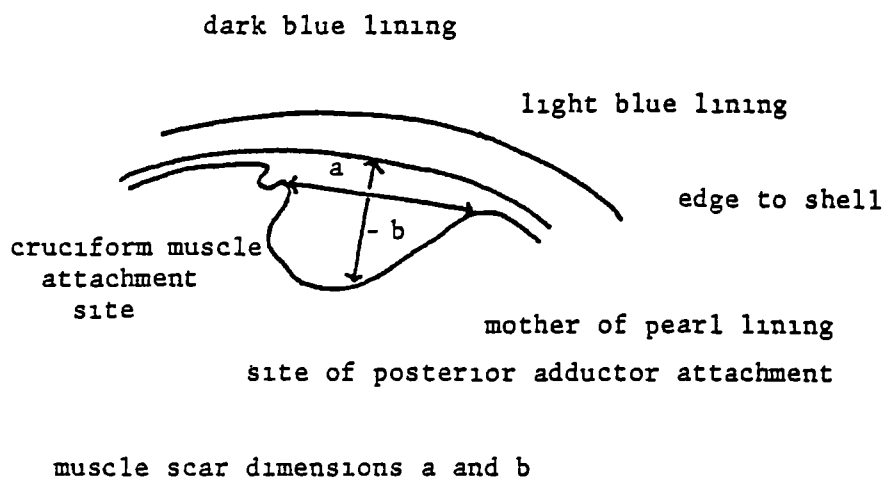

Appendix 2

Details of calculations of the foraging time required to achieve a positive energy balance (FT_0) in the Redshank, an example

Site Skinflats
 Temperature 8°C
 Windspeed 0 m s⁻¹

| | | Energy gain kJ.24 ⁻¹ h |
|------------------|----------------|-----------------------------------|
| Feeding time | 1 h | +32.4 |
| Preening/washing | 0 33 h | -3 2 |
| Flight | 0.25 h | -10.8 |
| Roost | <u>22.42 h</u> | <u>-178 4</u> |
| | 24 h | -160.0 |
| Feeding time | 2 h | +64 8 |
| Preening/washing | 0 33 h | -3.2 |
| Flight | 0.25 h | -10 8 |
| Roost | <u>21 42 h</u> | <u>-170 44</u> |
| | 24 h | -119.6 |
| Feeding time | 3 h | +97.2 |
| Preening/washing | 0.33 h | -3 2 |
| Flight | 0 25 h | -10 8 |
| Roost | <u>20 42 h</u> | <u>-162 5</u> |
| | 24 h | -79.3 |
| Feeding time | 4 h | +129 6 |
| preening time | 0 33 h | -3 2 |
| Flight | 0.25 h | -10 8 |
| Roost | <u>19.42</u> | <u>-154 55</u> |
| | 24 h | -38.95 |
| Feeding time | 5 h | +162.0 |
| Preening/washing | 0 33 h | -3 2 |
| Flight | 0 25 h | -10 8 |
| Roost | <u>18 42 h</u> | <u>-146 6</u> |
| | 24 h | +1.4 |

The 24 h energy balance is plotted against the time spent feeding overleaf

24 hour energy balance

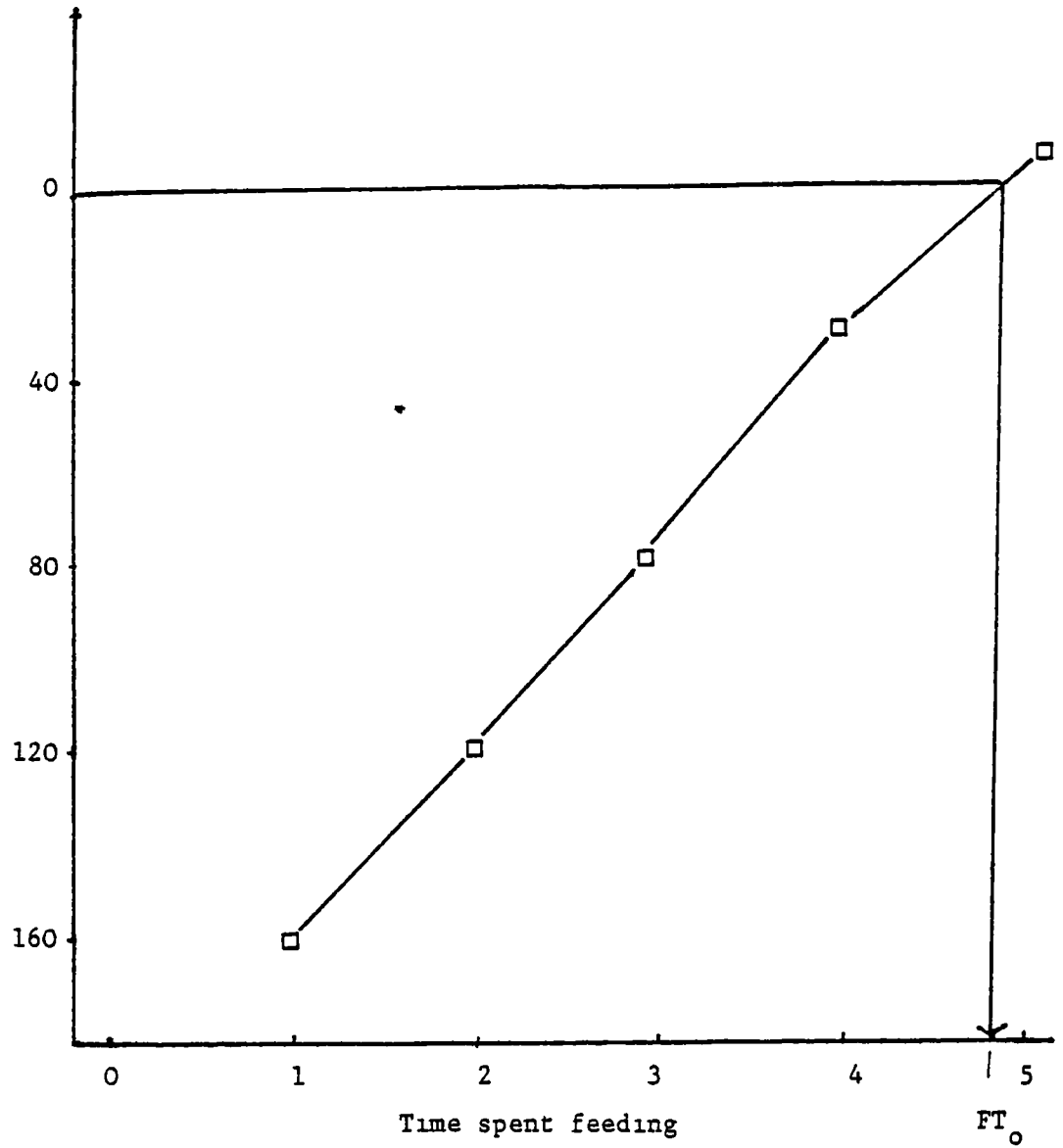

The time spent feeding required to achieve a positive energy interpolated from a 24 h energy balance where $kJ = 0$, equals 4.8 hours (See Fig 100, point A)

Appendix 3

Body lengths of British birds which are resident and summer visitors

| Family | Summer + Winter | | Summer only | Length | |
|---------------------------|-----------------------------|--------------------------|--------------------------|----------------------|-----|
| | Resident | Length | | | |
| Gaviidae | <i>Gavia arctica</i> | 25" | | | |
| | <i>Gavia stellata</i> | 22" | | | |
| Podicepsidae | <i>Podiceps cristatus</i> | 18" | | | |
| | <i>P. auritus</i> | 14" | | | |
| | <i>P. caspicus</i> | 12" | | | |
| | <i>P. ruficollis</i> | 10" | | | |
| Ardeidae | <i>Botaurus stellans</i> | 30" | | | |
| | <i>Ardea cinerea</i> | 36" | | | |
| Cygninae | <i>Cygnus olor</i> | 58" | | | |
| Anatidae | <i>Anas platyrhynchos</i> | 23" | <i>A. querquedula</i> | 15" | |
| | <i>A. strepera</i> | 20" | | | |
| | <i>A. acuta</i> | 28" | | | |
| | <i>A. penelope</i> | 18" | | | |
| | <i>A. crecca</i> | 14" | | | |
| | <i>Spatula clypeata</i> | 20" | | | |
| | <i>Tadorna tadorna</i> | 24" | | | |
| | <i>Aythya fuliginea</i> | 17" | | | |
| | <i>Aythya ferina</i> | 18" | | | |
| | <i>Somateria mollissima</i> | 24" | | | |
| | <i>Mergus serrator</i> | 22" | | | |
| | <i>Mergus merganser</i> | 25" | | | |
| | Accipitridae | <i>Aquila chrysaetos</i> | 32" | <i>Milvus milvus</i> | 25" |
| | | <i>Buteo Buteo</i> | 21" | | |
| | | <i>Acciptor nisus</i> | 13" | | |
| <i>Circus aeruginosus</i> | | 20" | <i>Circus pygorys</i> | 18" | |
| <i>Circus cyaneus</i> | | 18" | | | |
| Pandionidae | | | <i>Pandion haliaetus</i> | 22" | |
| Falconidae | <i>Falco peregrinus</i> | 18" | <i>Falco subbuteo</i> | 11.5" | |
| | <i>Falco columbarius</i> | 11 5' | | | |
| | <i>Falco tinnunculus</i> | 12 5" | | | |

Appendix 3 (contd)

| Family | Summer + Winter | | Summer only | Length |
|----------------|-----------------------|--------|----------------------|--------|
| | Resident | Length | | |
| Tetraonidae | Lagopus lagopus | 14' | | |
| | Lagopus mutus | 14" | | |
| | Tetrao erogallus | 28" | | |
| | Lyrurus tetrrix | 18" | | |
| Phasianidae | Alectoris rufa | 13 5" | Coturnix coturnix | 7" |
| | Perdix perdix | 12" | | |
| | Phasianus colchicus | 27" | | |
| Rallidae | Rallus aquaticus | 11" | Porzana porzana | 9" |
| | Gallinula chloropus | 13' | Crex crex | 10" |
| | Fulica atra | 15" | | |
| Heamatopodidae | Heamatopus ostralegus | 14" | | |
| Charadriidae | Vanellus vanellus | 12" | Charadrius dubius | 6" |
| | Charadrius hiaticula | 7" | Eudromias morinellus | 9" |
| | Pluvialis apricaria | 11" | Tringa hypoleucos | 8" |
| | Gallinago gallinago | 11)" | | |
| | Scolopax rusticola | 14" | | |
| | Numenius arquata | 22" | | |
| | Tringa totanus | 11" | | |
| Laridae | Calidris alpina | 7" | | |
| | Larus marinus | 27" | Sterna sandviciensis | 16" |
| | Larus fuscus | 21 | Sterna hirundo | 14" |
| | Larus argentatus | 22' | Sterna paradisaea | 15" |
| | Larus canus | 16" | Sterna dougalli | 15" |
| Columbidae | Larus ridibundus | 14" | Sterna albifrons | 9" |
| | Columba livia | 13" | Streptopelia turtur | 11" |
| | Columba oenos | 13" | | |
| | Columba palumbus | 16" | | |
| Cuculidae | Streptopelia decaocta | 11" | | |
| | | | Calculus conorus | 13" |
| Strigidae | Athene noctua | 9" | | |
| | Asio otus | 14" | | |
| | Asio flammeus | 15" | | |
| | Strix aluca | 15' | | |

Appendix 3 (contd)

| Family | Summer + Winter | | Length | Summer only | Length |
|---------------|-------------------------|--|-------------|-----------------------|--------|
| | Resident | | | | |
| Tytonidae | Tyto alba | | 14" | | |
| Caprimulgidae | | | | Caprimulgus europaeus | 11" |
| Apodidae | | | | Apus apus | 6.5" |
| Alcedinidae | Alceda althis | | 7" | | |
| Picidae | Picus viridis | | 12" | Jynx torquilla | 7" |
| | Dendrocapus major | | 9" | | |
| | D minor | | 6' | | |
| Alaudidae | Alauda arvensis | | 7" | | |
| | Lullula arborea | | 6" | | |
| Hirundinidae | | | | Riparia riparia | 5" |
| | | | | Hirundo rustica | 7.5" |
| | | | | Delichon urbica | 5" |
| Motacillidae | Anthus praetensis | | 6" | Anthus trivialis | 6' |
| | Anthus spinoletta | | 6.5" | Motacilla flava ssp | 6.5" |
| | Motacilla cinerea | | 7" | | |
| | Motacilla alba ssp | | 7" | | |
| Lanidae | | | | Lanius collurio | 7" |
| Sturnidae | Sturnus vulgaris | | 8 5" | | |
| Corvidae | Garrulus glandarius | | 14" | | |
| | Pica Pica | | 18" | | |
| | Pyrrhocorax pyrrhocorax | | 15" | | |
| | Corvus monedula | | 13" | | |
| | Corvus frugilegus | | 18" | | |
| | Corvus corone ssp | | 18" | | |
| | Corvus corax | | 25' | | |
| Cinclididae | Cinclus cinclus | | 7" | | |
| Troglodytidae | Troglodytes troglodytes | | 4" | | |
| Prunellidae | Prunella modularis | | 6" | | |
| Musicapidae | Sylvia atricapilla | | 5.5" | Locustella naervia | 5" |
| | Sylvia undata | | 5' | Acrocephalus | |
| | | | | schoenobaenus | 5" |
| | Regulus regulus | | 3 5" | A palustris | 5" |
| | | | A sciraceus | 5" | |

Appendix 3 (contd)

| Family | Summer + Winter | | Summer only | Length | |
|-----------------------------|----------------------------|--------------------------|-----------------------------|------------------------------|-------|
| | Resident | Length | | | |
| Musicapidae (contd) | | | <i>Sylvia borin</i> | 5 5" | |
| | | | <i>S communis</i> | 5 5" | |
| | | | <i>S. curruca</i> | 5.5" | |
| | | | <i>Phylloscopus</i> | | |
| | | | <i>trochilus</i> | 4.25" | |
| | | | <i>P collybita</i> | 4.25" | |
| | | | <i>P sibilatrix</i> | 5" | |
| | | | <i>Regulus ignicapillus</i> | 3.5" | |
| | | <i>Panurus biormicus</i> | 6 5" | <i>Ficedula hypoleuca</i> | 5" |
| | | | | <i>Muscicapa striata</i> | 5 5" |
| | Turdinae | <i>Saxicola torquata</i> | 5" | <i>Oeonthe oeonthe</i> | 5.75" |
| <i>Phoenicurus schruros</i> | | 5 5" | <i>Saxicola rubetra</i> | 5" | |
| <i>Erithacus rubecula</i> | | 5 5" | <i>Phoenicurus</i> | | |
| | | | <i>phoenicurus</i> | 5.5" | |
| | | <i>Turdus merula</i> | 10" | <i>Luscinia megarhynchos</i> | 6.5" |
| | | <i>Turdus philometos</i> | 9" | <i>Turdus torquatus</i> | 9.5" |
| | | <i>T. viscivorus</i> | 11" | | |
| Paridae | <i>Parus polustris</i> | 4 5" | | | |
| | <i>Parus montanus</i> | 4 5" | | | |
| | <i>Parus cristatus</i> | 4 5" | | | |
| | <i>P. caeruleus</i> | 4 5" | | | |
| | <i>P. ater</i> | 4 5" | | | |
| | <i>P. major</i> | 5.5" | | | |
| | <i>Aegithalos caudatus</i> | 5 5" | | | |
| | <i>Sitta europaea</i> | 5 5" | | | |
| Certhiidae | <i>Certha familiaris</i> | 5" | | | |
| Pioceidae | <i>Passer domesticus</i> | 5 75" | | | |
| | <i>Passer montanus</i> | 5.5" | | | |
| Fringillidae | <i>Fringilla coelebs</i> | 6" | | | |
| | <i>Pyrrhula pyrrhula</i> | 5 75" | | | |
| | <i>Coccothraustes</i> | | | | |
| | <i>coccothraustes</i> | 7" | | | |
| | <i>Carduelis chloris</i> | 5 5" | | | |
| | <i>Carduelis spinus</i> | 4 5" | | | |

Appendix 3 (contd)

| Family | Summer + Winter | | Summer only | Length |
|--------------|------------------------------|--------|-------------|-----------|
| | Resident | Length | | |
| Fringillidae | <i>Carduelis carduelis</i> | 4 75" | | |
| | <i>Acanthis cannabina</i> | 5 | | |
| | <i>Acanthis flavirostris</i> | 5 25" | | |
| | <i>A flammea</i> | 5" | | |
| | <i>Loxia curvirostra</i> | 6 5" | | |
| Emberizidae | <i>Emberiza colandra</i> | 7" | | |
| | <i>E. schoeniclus</i> | 6" | | |
| | <i>E. citrineus</i> | 6 5" | | |
| | <i>E. cirius</i> | 6 5" | | |
| | <i>Plectrophenox nivalis</i> | 6.5" | | |
| | | n | <u>109</u> | <u>45</u> |
| | | x | 14.19" | 8.69" |
| | | | t = 2.98 | |
| | | | p 01 | |