

Thesis
1711

THE EFFECTS OF ALUMINIUM ON SOME ASPECTS OF THE PHYSIOLOGY
AND GILL HISTOPATHOLOGY OF THE NILE TILAPIA,
OREOCHROMIS NILOTICUS (L.), IN ACIDIC WATER

A THESIS SUBMITTED TO THE UNIVERSITY OF STIRLING FOR THE
DEGREE OF DOCTOR OF PHILOSOPHY

BY

A. R. MOLLAH, B.Sc.(Hons.), M.Sc.

INSTITUTE OF AQUACULTURE
UNIVERSITY OF STIRLING
STIRLING, SCOTLAND

APRIL 1991



7/91

THE BRITISH LIBRARY DOCUMENT SUPPLY CENTRE

BRITISH THESES NOTICE

The quality of this reproduction is heavily dependent upon the quality of the original thesis submitted for microfilming. Every effort has been made to ensure the highest quality of reproduction possible.

If pages are missing, contact the university which granted the degree.

Some pages may have indistinct print, especially if the original pages were poorly produced or if the university sent us an inferior copy.

Previously copyrighted materials (journal articles, published texts, etc.) are not filmed.

Reproduction of this thesis, other than as permitted under the United Kingdom Copyright Designs and Patents Act 1988, or under specific agreement with the copyright holder, is prohibited.

THIS THESIS HAS BEEN MICROFILMED EXACTLY AS RECEIVED

**THE BRITISH LIBRARY
DOCUMENT SUPPLY CENTRE
Boston Spa, Wetherby
West Yorkshire, LS23 7BQ
United Kingdom**

DEDICATED

TO

MY WIFE AND CHILDREN

ABSTRACT

The aims of this study were to investigate the physiological effects of aluminium in the tilapia, *Oreochromis niloticus* (L.), in an acidic environment and to evaluate the possible ameliorative effects of external calcium concentrations. Experiments were conducted in a flow-through exposure system employing synthetic water of precisely known composition, thus facilitating the stringent control of the chemical and physical variants in the exposure media. A pH of 5.2 at two calcium concentrations (0.6 and 16.0 mg l⁻¹) and a number of aluminium concentrations (0-520 µg l⁻¹) were selected, thus allowing the investigation of the interactive effects of calcium and aluminium in the manifestations of toxic actions. Both short-term (4 days) and chronic (21 days) exposure schedules were followed.

A series of experiments was carried out to investigate aluminium-induced changes in plasma and tissue concentrations of Na⁺, K⁺, Ca²⁺ and Mg²⁺, and plasma glucose and total protein concentrations, and plasma osmolality. Changes in blood haematocrit levels and haemoglobin concentrations were also measured. Concentration-dependent responses were observed in most of the parameters. Plasma sodium, and tissue sodium and potassium concentrations decreased with a concomitant decline in plasma osmolality, while, in general, plasma potassium and calcium concentrations increased. Plasma glucose levels were greatly elevated by acid/aluminium exposure. Both blood haematocrit levels and haemoglobin concentrations were raised, accompanied by a marked swelling of erythrocytes. Qualitatively similar results were observed in both short-term and chronic exposure experiments. However, responses were modified (both qualitatively and quantitatively) with exposure time during chronic exposures. Increased calcium concentrations in the exposure media reduced or abolished acid/aluminium-induced changes in the majority of the parameters and were particularly effective in reducing ion loss from the body. The manifestation and magnitude of a particular response was clearly dependent upon aluminium and calcium concentrations in the exposure media and duration of the exposure.

Both *in vitro* and *in vivo* effects of aluminium on the activity of two ion-transporting enzymes, Na⁺/K⁺-ATPase and Ca²⁺-ATPase, in gills of tilapia were measured. *In vitro* exposure inhibited the activity of the enzymes while both stimulatory and inhibitory effects of aluminium were observed during *in vivo* exposure, the magnitude of the response again being dependent upon aluminium and calcium concentrations in the media.

Mobilization of body calcium reserves in tilapia during acid/aluminium exposure using radiolabelled calcium (⁴⁵Ca) was also investigated. Results indicated that low calcium water and the presence of aluminium in the media independently and in combination increased calcium turnover rates in the body and reduced calcium content in the scales while muscle tissue and bone calcium concentrations were little affected.

Light and electron microscopic studies on gill tissue were carried out in order to investigate structural and ultrastructural changes caused by acid/aluminium exposure. Characteristic pathological changes included epithelial swelling and secondary lamellar fusion, proliferation and hypertrophy of chloride and mucous cells, loss of surface microridges, epithelial lifting, and degenerative changes in different cell types. Higher aluminium concentrations were required in high calcium water to elicit a response similar to that in low calcium water conditions. The changes in gill tissues appeared to be consistent with the physiological observations made during the present study.

Under these experimental conditions, tilapia were physiologically affected in a deleterious manner by concentrations as low as 100 and 150 µg Al l⁻¹, in both low calcium and high calcium water conditions, respectively, indicating that aluminium is potentially toxic to fish in tropical environments. The study also confirms the ameliorative role of calcium on aluminium toxicity and indicates that the discrepancies apparent among previous studies may have resulted from differences in the molar ratios of aluminium and calcium used.

ACKNOWLEDGEMENTS

It is my pleasure to express my sincere gratitude to my principal supervisor, Dr. M. C. M. Beveridge, for his guidance, support and constructive criticism throughout the study and in the production of this thesis. I remain eternally grateful for his patience and understanding during my moments of difficulty. I am also grateful to my additional supervisor, Dr. M. J. Phillips, for his constant advice, suggestions and encouragement.

It would have been impossible to carry out the radioisotopic work of this study without the generous help, suggestion and advice from Dr. S. George, of the Department of Biological Sciences, University of Stirling, and to him I am very grateful.

Help and suggestions received from Dr. L. G. Ross, Dr. N. Freirich, Dr. R. Wootten, Dr. Mary Tatner and Dr. D. Baird of the Institute of Aquaculture, at the time of my needs are gratefully acknowledged.

Thanks are due to Dr. C. Exley who induced my interests in aluminium toxicity. I am also very much thankful to Dr. Lakshmikantham who helped me in various ways and in particular with electron microscopy.

I wish to extend my sincere appreciation to the staff of the Institute of Aquaculture, especially Julia Farrington, Laura Cumming, Betty Stenhouse and Sheila.

In the course of my study I have been benefited by the technical expertise of various technical staff and my sincere thanks in particular are due to William Struthers of the water quality division, Stuart Miller, Keith Ranson, Ian McEven, Allan Porter, Mairi Beveridge, Laura Sinclair.

I wish to thank all my colleagues and friends at the Department of Zoology, University

of Dhaka, Dhaka, for their support during my absence. I also thank my colleagues and fellow countrymen at the Institute of Aquaculture for their generous help and hospitality throughout my study period.

I must acknowledge the Commonwealth Scholarship Commission in the U. K. for providing me the financial assistance during the term of my study.

Lastly, but no means the least, my heartfelt thanks must go to my mother, brother and sisters for their patience and support.

CONTENTS

Abstract	i
Acknowledgements	ii
Chapter 1 General Introduction	
1.1 Surface Water Acidification and Associated Problems	1
1.2 Occurrence of Acid Water in Tropical Environments	2
1.3 Origin and Chemistry of Aluminium	5
1.4 Effects of Acid/Aluminium Exposure on Fish	
1.4.1. Physiological Effects	8
1.4.2. Histopathology	16
1.4.3. Effects on Egg Hatchability, Growth/Reproduction	18
1.5 Mechanisms of Acid/Aluminium Toxicity	20
1.6 Influence of External Calcium Concentrations on Gill Structure and Functions	22
1.7 Regulation of Ionic Balance in Fish	24
1.8 Problems and Scope in Physiological Investigations in Fish under Acid/Aluminium Stress	26
1.9 Objectives of the Present Study	29
Chapter 2 General Materials and Methods	
2.1 The Fish, Source and Maintenance of Fish Stock	31
2.2 The Fish Exposure System and the System Protocol	31
2.2.1 Deionization of Water	33
2.2.2 Maintenance of Ionic Composition of Exposure Media	35
2.2.3 Maintenance of pH and Temperature	35
2.2.4 Exposure Tank Unit, Water Distribution	37
2.2.5 Toxicant Dosing	38
2.3. Pre-exposure Acclimation of Fish	38
2.4. Pre-exposure Experimentation Protocol	38
2.5. Monitoring Water Quality	39
2.6. Determination of Aluminium Content in Gill Tissue	40
Chapter 3 Effects of Short-term Acid/Aluminium Exposure on Some of the Blood and Tissue Parameters of Tilapia, <i>Oreochromis niloticus</i>	
3.1 Introduction	41
3.2 Materials and Methods	46
3.2.1 Experimental Protocol	
Experiment 1. Preliminary investigation of ameliorating effects of ambient calcium concentrations on ionic balance in tilapia	46
Experiment 2. Investigation into the interactive effects of calcium and aluminium on the ionic status and some haematological parameters in tilapia	47

Experiment 3. Further investigations into the effects of different aluminium concentrations under low and high calcium conditions	48
3.2.2 Collection of Blood	50
3.2.3 Collection of Muscle Tissue and Preparation of Tissue Digests for Electrolyte Analysis	51
3.2.4 Collection and Preparation of Gill Tissue Digests	51
3.2.5 Visual Observation of Fish and Physical Appearance	51
3.2.6 Analytical Procedure	52
3.2.7 Statistical Analysis and data Reporting	55
3.3. Results	
3.3.1. Experiment 1	
3.3.1.1 Water Quality	56
3.3.1.2 Fish Mortality	56
3.3.1.3 Blood Parameters	56
3.3.2 Experiment 2	
3.3.2.1 Water Quality	62
3.3.2.2 Blood Parameters	62
3.3.3 Experiment Series 3	
3.3.3.1 Water Quality	71
3.3.3.2 Visual Observation of Fish	74
3.3.3.3 Blood Parameters	76
3.3.3.4 Muscle Tissue Parameters	87
3.3.3.5 Aluminium Content in Gill Tissue	90
3.4 Discussion	
3.4.1 Water Quality	93
3.4.2 Fish Behaviour and Physical Appearance	94
3.4.3 Blood and Tissue Parameters	96
3.4.4 Aluminium Accumulation in Gill Tissue	109
 Chapter 4 Effects of Chronic Acid/Aluminium Exposure on Some of the Blood and Tissue Parameters of Tilapia, <i>O. niloticus</i>	
4.1 Introduction	112
4.2 Materials and Methods	
4.2.1 Experimental Protocol and Analytical Methods	114
4.2.2 Statistical Analysis	115

4.3 Results	
4.3.1 Water Quality	116
4.3.2 Blood Parameters	116
4.3.3 Muscle Tissue Parameters	128
4.3.4 Aluminium Content in Gill Tissue	130
4.4 Discussion	133
Chapter 5 Effects of Acid/Aluminium Exposure on the Gill Na ⁺ /K ⁺ -ATPase and Ca ²⁺ -ATPase activity of Tilapia, <i>O. niloticus</i>	
5.1 Introduction	137
5.2 Materials and Methods	141
5.2.1 Experimental Protocol	
5.2.1.1 Experiment 1: Exposure to Acid Conditions	141
5.2.1.2 Experiment 2: Short-term Exposure to Acid/ Aluminium conditions	141
5.2.1.3 Experiment Series 3: Chronic exposure to Acid/ Aluminium conditions	142
5.2.2 Preparation of Gill Homogenate for Enzyme Assay	142
5.2.3 Enzyme Assay	143
5.2.4 <i>In vitro</i> Experiment	146
5.2.5 Statistical Analysis	147
5.3 Results	
5.3.1 Experiment 1	148
5.3.2 Experiment 2	
5.3.2.1 Water Quality	148
5.3.2.2 Enzyme Activity	151
5.3.2.3 Gill Aluminium Content	151
5.3.3 Experiment Series 3	
5.3.3.1 Water Quality	153
5.3.3.2 Enzyme Activity	153
5.3.3.3 Gill Aluminium Content	157
5.3.4 <i>In Vitro</i> Experiments	160
5.4 Discussion	162
Chapter 6 Effects of Acid/Aluminium Exposure on the Calcium Metabolism in Tilapia, <i>O. niloticus</i> ,	
6.1 Introduction	171

6.2 Materials and Methods	
6.2.1 The Source of Fish and Pre-exposure Acclimation	175
6.2.2 Prelabelling of Tissue with ⁴⁵ Ca	
6.2.3 Exposure Protocol	175
6.2.4 Preparation of Tissue Samples for Analysis	176
6.2.5 Counting of Radioactivity	177
6.2.6 Determination of Total Calcium in Tissue Digest	177
6.2.7 Determination of Aqueous Aluminium	177
6.2.8 Statistical Analysis	178
6.3 Results	
6.3.1 Aluminium Concentration in the Exposure Media	179
6.3.2 ⁴⁵ Ca Retention in Different Tissues	179
6.3.3 Total Calcium Content	184
6.4 Discussion	
6.4.1 Aluminium Concentration in the Exposure Media	188
6.4.2 Effect of Exposure Calcium Concentrations	189
6.4.3 Effect of pH	191
6.4.4 Effect of Aluminium Concentration	192
6.4.5 Total Calcium Concentrations and ⁴⁵ Ca Dynamics in Different Tissue Compartments	194
 Chapter 7 Effects of Acid/Aluminium Exposure on the Gill Histopathology of Tilapia, <i>O. niloticus</i> .	
7.1. Introduction	197
7.2 Materials and Methods	
7.2.1 The Source of Materials and Tissue Sampling	199
7.2.2 Light Microscopy	200
7.2.3 Electron Microscopy	
7.2.3.1 Scanning Electronmicroscopy	201
7.2.3.2 Transmission Electronmicroscopy	202
7.3 Results	
7.3.1 Chronic Exposure	207
7.3.2 Short-term Exposure	225
7.4 Discussion	236
 Chapter 8 General Discussion	245
List of References	258

Appendix-1	283
Appendix-2	284
Appendix-3	285
Appendix-4	286
Appendix-5	287
Appendix-6	288
Appendix-7	289

CHAPTER 1
GENERAL INTRODUCTION

1.1. Surface Water Acidification and Associated Problems

Acidification of natural water is an important ecological problem facing the world today and may well remain a significant problem of the foreseeable future. The extensive presence of acidic waters in Scandinavia, parts of the U.K. and northeastern America, and its damaging impact on fish and fisheries is well documented (Haines, 1981; Spry *et al.*, 1981; Howells, 1983; Exley and Phillips, 1988), and has caused scientific and political concern in these regions throughout the past few decades (Howells and Morris, 1989; McCormick, 1990).

The atmospheric deposition of acid radicles (SO_2 and NO_x) either in dry or wet state, originating from the use of fossil fuel in heavily industrialized countries, is thought to be the main reason for surface water acidification. Hydrological and geological characteristics of the catchment area, however, play an important role in determining the degree of acidification of a water body. Rivers or lakes that drain water from catchment areas containing base-poor rocks or ion depleted soils are particularly vulnerable to surface water acidification. In addition, rivers and lakes receiving industrial and mine waste drainage are acidic as a result of acid discharge or leaching of sulphur compounds which oxidize to sulphate. Besides the above man-made sources, several natural processes produce H^+ in the soil and reduce the pH of the percolating water. These include the production of carbonic acid by CO_2 , the hydrolysis of minerals, the decomposition and nitrification of ammonium produced by bacterial decomposition of vegetation and by fertilizers, the oxidation of dry soil, the action of organic acids from decaying humus and the release of H^+ from the roots of plants to compensate for the uptake of calcium and magnesium ions (Hagen and Largeland, 1973; Scofield, 1976; Henriksen, 1982; Mason, 1989). The latter processes could be important factors for the acidification of tropical ecosystems.

Besides the direct effects of acidic water itself on fish populations, an important consequence of catchment weathering by acid precipitation is the mobilization and transfer of metal ions from edaphic environment to the aquatic environment (Driscoll *et al.*, 1980). Thus, many trace metals are found to be elevated in acidic environments (Wright and Gjessing, 1976; Dickson, 1983; see also Exley and Phillips, 1988, for a review) and among those aluminium has caused the greatest concern because of its widespread occurrence in acidified water and its possible link with declines in fish populations (Norton, 1982; Brown and Sadler, 1989, for reviews). Studies of water chemistry of rivers and lakes of northeastern America, the U.K. and Scandinavia have shown that the more acidic waters, are the higher the concentrations of aluminium (Baker, 1982, for a review). In a study conducted in upland areas of England and Wales biomass and population density of salmonids were positively correlated with pH, calcium and alkalinity and negatively with aluminium concentration and concentrations of other metals (Turnpenny, 1985). According to Turnpenny it is the levels of aluminium and other metals but not the pH *per se* which is at the root of population decline in acidic environments. Similarly, analysis of survival of brook trout stocked into 53 Adirondack lakes as a function of 12 water quality parameters indicated aluminium to be the primary chemical factor controlling trout survival (Schofield and Tronjar, 1980). By now, it is well established through toxicological studies, from both laboratory and field, that aluminium in the acidic environment can be acutely and chronically toxic to fish (for reviews: Baker, 1982; O'Donnell *et al.*, 1984; Exley and Phillips, 1988; McDonald *et al.*, 1989; Brown and Sadler, 1989). The present study, therefore, aimed to investigate the toxic effects of such an important metal, aluminium, on fish in an acidic environment.

1.2. Occurrence of Acid Waters in Tropical and Subtropical Environments

It is generally thought that acidification of surface waters is a problem in the western industrialized countries of temperate regions. However, acidic surface waters have been

reported from many areas of tropical and subtropical countries. The aim of this Section is to bring together the information on the distribution of acidic waters in the tropical and subtropical environments. Most of the tropical and subtropical acid waters mainly originate from two sources, acid sulphate soils and as a biological processes (see above) in catchments with low buffering capacity. In the recent past, occurrence of 'Acid Rain' has been reported from the southern hemisphere. Longrange air-borne pollutants originating from the developed countries may well cross political boundaries. Moreover, the recent industrial development in many countries of those regions has increased the emission of SO₂ and NO_x considerably and the situation is worsening rapidly (McCormick, 1990). The 'International Conference on Acidification of Tropical Ecosystems'-held in Caracas, Venezuela, April, 1986, expressed growing concern about the problem (mentioned in McCormick, 1990).

The waters of some lakes and rivers in Australia, in particular Frazer Island and Queensland, are acidic with pH values ranging from 4.1 to 6.0 and are very low in conductivity (Bayly *et al.*, 1975). Similarly, in southern Malaysia black waters with pH 3.6 to 5.4 are known to occur (Jhonson, 1968). These waters are also very low in conductivity. Water draining the Malacca area has a pH as low as 1.8. Lake Subang in West Malaysia is known to have very low calcium and magnesium concentrations of 0.2 to 2.8 and 0.1 to 3.2 mg l⁻¹, respectively, with a pH of 4.6 (Arumugan and Furtado, 1980). In River Pahan basin and lake Tasek-Bera acid black water with a low pH of ≤4.7 is common (Serruya and Pullingher, 1983). In India, some lakes are reported to be acidic after a prolonged period of drying. A pH value as low as 3.8 has been observed in lake Vembanad. The low pH of soil in the catchment area is the probable cause (Pilli *et al.*, 1985).

In Africa, the presence of acidic waters has been documented in many river and lake systems. The southern part of the Zaire river is characterized by blackwater with pH

values of 3.5 to 5.2 and low calcium and magnesium concentrations of 1.7 and 1.04 mg l⁻¹, respectively, (Meybeck, 1978). An aluminium concentration of 36 µg l⁻¹ was reported in that study. Lake Tumba which drains into River Zaire has a thick layer of kaolinite (aluminium compound) on the lake bottom covered by organic debris. The water of this lake has a very low calcium and magnesium content of 0.7 and 0.3 mg l⁻¹, respectively, and having pH values ranging from 4.5 to 5.0. A low pH of 4.0 has been reported to occur in lake Maji-Ndombe (Beadle, 1974; McConnell-Lowe, 1975; Serruya and Pullingher, 1983). Loveshin (1982) mentioned that in some tributaries of the Congo river, the pH may fall below 5.0. Acidic waters have also been observed in some volcanic lakes in Africa. For example, lake Hara Orgona in southern Ethiopia is the most well known with a pH of 3.2 (Loffler, 1978).

In South America many rivers and lakes are also characterized by acid water of varying acidity. In the Amazon, the largest river system in the world, two types of acid water have been identified, blackwater and clearwater. The black water is usually found in the upper Rio Nigro river and associated tributaries, and the acidity probably originates from the incomplete oxidation of organic matter. This water is rich in iron and aluminium and poor in base metals, with pH 3.8 to 4.9 (Sioli, 1964; 1968). The clear water of some upper tributaries, which drains through brown loam soil, resulting from the weathering of granite and gneiss of the procambrian era, is very poor in minerals and has a conductivity of ≤10 µS cm⁻¹ and a pH of 4.0-6.6 (Serruya and Pullingher, 1983). Acid water having pH values of 4.2 to 6.8 has been reported in Orinoco and Casiquiare reservoir (Edwards and Thomes, 1970). The pH of Guri reservoir is usually found to be below 6.5 with a very low calcium concentration (<1 mg l⁻¹) (Lewis and Weibezhan, 1976)). Lake Nabugado has a water pH of 4.7 (mentioned in Serruya and Pullingher, 1983).

Another major source of acid water in tropical lake and river systems is acid sulphate

soils. This soil is rich in pyrite which, on oxidation, produces large amounts of sulphuric acid. The acidity, in turn, releases iron and aluminium in water that can be toxic to fish (Simpson and Cook, 1983; Singh, 1985). Acid sulphate soils are reported to occur in many freshwater and brackishwater mangrove tidal swamp areas. The world wide extent of acid sulphate soils is about 13 million ha, of which 5 million are in southeast Asia. The pH of waters in such areas is often below 4.0 and aluminium concentrations have been reported to vary between 0.5 and 26.0 mg l⁻¹ (Singh, 1985).

1.3. Origin and Aquatic Chemistry of Aluminium

Aluminium is the third most abundant element comprising about 7% of the earth's crust. The free metal form of aluminium does not exist in nature, although aluminium compounds are found to a lesser or greater extent in all rocks and plants. Weathering of these rocks gives rise to a variety of compounds (e.g. gibbsite, kaolinite, cryolite etc., for example) that are leached into the aquatic environment (O'Donnell *et al.*, 1984; Exley and Phillips, 1988, for reviews).

The atmospheric deposition of aluminium in aquatic ecosystems is negligible (Peirson *et al.*, 1974). Several anthropogenic sources such as dye and paper manufacturing, tanning industries, taconite processing, water treatment using alum as coagulant, coal mining and oil shale mining (Freeman and Everhart, 1971; Sorensen *et al.*, 1974; Boyd, 1979; Buergel and Soltero, 1983) may contribute to aluminium contamination of the aquatic environment. However, such activities are localized and insignificant compared to the widespread occurrence of aluminium in acidic environments. Depending on water quality, the products of weathering of aluminium-containing rocks are leached out into the aquatic environment (Exley and Phillips, 1988, for review) and are considered to be the main source of aluminium pollution in natural waters (Driscoll *et al.*, 1980). In natural waters of circumneutral pH and low concentrations of complexing agent (e.g. fluorides, silica, humic substances), the concentrations of soluble aluminium are

relatively low (Nordstrom, 1982) due to the insoluble nature of hydroxides, gibbsite and kaolinite (Hem, 1970). However, the solubility of these compounds increases dramatically as pH falls. For example, when the pH decreased from 5.68 to 4.73 the concentration of aluminium in the Hubbard Ecosystem increased almost 900% (Johnson *et al.*, 1981).

The chemistry of aluminium in aquatic environments is complicated and is influenced by various physico-chemical factors, of which ambient pH is the most important. Water pH not only controls the solubility of aluminium but also dictates its speciation. According to Burrows (1977) the aquatic chemistry of aluminium is essentially that of its hydroxides and differs from that of other non-transitional metals in three important ways; (a) it is readily amphoteric (donates or accepts H⁺), (b) it forms complexes with other substances, and (c) it tends to polymerise in the aquatic environment. Solubility of aluminium is a direct function of ambient pH, decreasing to a minimum between pH 5.5 and pH 6.5 (see Burrows, 1977 and Roberson and Hem, 1969) and increasing towards both extremes of the pH scale. Because of amphoterism, it forms cationic monomeric species (e.g. Al³⁺, Al(OH)²⁺, Al(OH)₂⁺) at pH values less than 5.5 and soluble aluminate species, e.g. Al(OH)₄⁻, at pH greater than 5.5. Between pH 5.5 and 6.5 most aluminium is in the form of Al(OH)₃ (Burrows, 1977; see also Odonnell *et al.*, 1984). Aluminium salts of non-complexing acids dissociate in water to produce a hexaquo aluminium-complex Al(H₂O)₆³⁺. Subsequent hydrolysis yields an acidic solution:

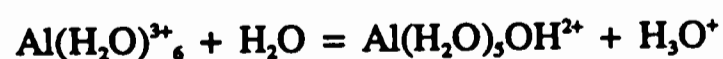

Progressive hydrolysis leads to the formation of colloidal aluminium hydroxide:

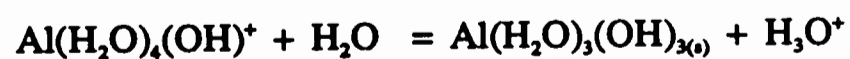
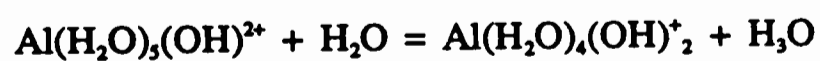

In basic solutions, addition of further aluminium leads to the formation of soluble aluminate ion Al(OH)₄⁻.

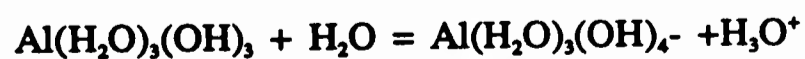

High concentrations of hydroxy-aluminium compounds (when exceeds amorphous solubility) or ageing of aluminium stimulates polymerization of the hydroxy-metal species (Hem, 1968). This tendency increases as the ratio of the aluminium-bound hydroxyl to aluminium increases from 0 to 3 (see Odonell *et al*, 1984); for example:

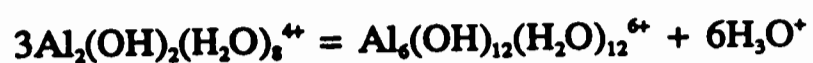

Further combination of the hexomers results in the precipitation of the neutral mineral gibbsite. The intermediate aluminium species are metastable although the ageing process can be strongly long. The polymers are generally heavier than monomeric forms, and as a result they tend to precipitate thereby reducing their availability to aquatic organisms.

In natural waters of low pH, the aquatic chemistry of aluminium is further complicated by the presence of a number of other inorganic and organic anions capable of forming coordinated bonds with aluminium. Important inorganic complexing ligands include fluoride, sulphate and silicic acid. Both aqueous fluoride and sulphate complex with aluminium and may affect both absolute and relative proportions of aluminium-hydroxy species. The rate of complexation is controlled by both water pH and temperature (Burrows, 1977; Planky *et al.*, 1985; Exley and Phillips, 1988). Aluminium combines with dissolved silica to give aluminosilicates by complexing with both monomeric aluminium-hydroxy species or aluminate anions and the ultimate complex is a colloidal solid and, thus, may be unavailable to aquatic organisms (Hem *et al*, 1973; Birchall *et al*, 1989). The precipitation of aluminium hydroxide in natural waters is also affected by the presence of chloride anions. For example, the rapid precipitation of $\text{Al}(\text{OH})_3^{(s)}$ in the presence of elevated chloride levels occurs in the absence of other electrolytes, between pH 7.3-7.4 (Exley and Phillips, 1988; for a review). Important, too, is the ability of aluminium to complex with organic molecules which also increases its solubility. A wide variety of organic acids, notably, fulvic and humic acids bind

aluminium in the acid solution. Binding to aluminium is via carboxylate, phenolic and silicic acid-like groups (Tipping *et al.*, 1988) and is dependent on pH, temperature and fluoride levels (Pott *et al.*, 1985). Although the organic ligands increase aluminium solubility, they can reduce aluminium toxicity by reducing the further complexation at the gill surface (Exley and Phillips, 1988; Witters *et al.*, 1990).

1.4. Effects of Acid/Aluminium Exposure on Fish

This Section surveys the main research which has been carried out on the effects of aqueous aluminium on the physiology, growth and histopathology of fish. The effects of aluminium on other animals and the effects of similarly acting metals on fish will, where necessary, be included in the latter chapters.

1.4.1. Physiological Effects of Acid/Aluminium Exposure

Table 1.1. summarizes the results and the exposure conditions of the main research works on physiological problems in fish. The highlights of results from those studies are discussed below.

1.4.1.1. Effects on Ion Fluxes

Several studies (ref. no. 1-8; Table 1.1) have investigated the effects of acid/aluminium exposure on ion fluxes in fish. Aluminium has been found to reduce the netflux of sodium (ref. no. 1-6), potassium (ref. no. 3, 4) and chloride (ref. no. 3, 4, 7) although not calcium ions (ref. no. 3, 4, 8) in fish. The loss of ions was found to be branchial rather than renal. The net loss of ions was the result of either inhibition of influx or stimulation of efflux or a combination of both. Several of the studies have shown that aluminium exposure had caused inhibition of influx at low pH and stimulated efflux at higher pH (ref. no. 1, 2, 7). The effects of external calcium on aluminium induced changes in ion flux are conflicting. External calcium concentrations may (ref. no. 4, 6) or may not (ref. no. 1, 3) ameliorate toxic effects of aluminium on ion flux. Prior

acid/aluminium, although not acid alone, acclimation of fish may confer greater resistance to subsequent acute exposure to acid/aluminium (ref. no. 5, 6).

1.4.1.2. Effects on Ionic and Osmotic Balance

Ionic imbalance in fish has been identified as the main toxic syndrome of acid/aluminium toxicity in fish. A large number of studies have reported the acid/aluminium-induced reductions in plasma sodium and chloride ion concentrations (ref. no. 3, 4, 6, 9, 11-22, 24, 25; Table 1.1), although a few workers did not observe these phenomena (ref. no. 14, 22). These effects were more pronounced in lower pH than in higher pH conditions (ref. no. 13, 22). Consistent with ion flux studies, few workers have observed the mitigating effects of external calcium concentrations on the acid/aluminium-induced changes in plasma ion loss (ref. no. 4, 21), while a few studies did not demonstrate such effects (ref. no. 3, 22). In general, plasma potassium (ref. no. 3, 17, 19, 21, 22) and calcium (ref. no. 15, 17, 19) concentrations were elevated by acid/aluminium stress. However, some studies (ref. no. 21, 22) did not find any significant changes in plasma calcium concentrations, while other ions were affected. Whole body content of major ions were also found to be affected by acid/aluminium exposures (ref. no. 28, 29, 30).

1.4.1.3. Effects on Respiration, Acid-Base Status and Haematology

Acid/aluminium exposures have consistently been shown to reduce oxygen tension (pO_2) and to increase carbon dioxide tension (pCO_2) in blood of a variety of fish species (ref. no. 9, 10, 13, 14, 17, 20-23, 27; Table 1.1) These effects of acid/aluminium exposures were found to be more severe under higher pH than lower pH conditions (ref. no. 9, 13, 20, 22). While higher external calcium concentrations in the exposure media exacerbated the respiratory distress (ref. no. 22; see also ref. no. 14, 17), Playle *et al.* (1989) reported that external calcium concentrations reduced the acid/aluminium-induced changes in blood gas tension. Although pO_2 tension in blood was reduced by

Table-1.1. Physiological Effects of Aluminium Toxicity to Fish

Ref. No.	Fish and Exposure Conditions	Observations	References
1	pH= 7.0-4.0; Al= 8umol/l; Ca=0.01 and 0.05 mmol/l; static exposure in synthetic water. Fish: <i>Salmo trutta</i> .	Low pH itself had little effect on sodium influx but tended to increase influx. Aluminium addition significantly reduced influx at pH 4.5 and 4.0. Efflux was unaffected. Aluminium concentrations at pH 7.0 and 5.4 had no such effects. Higher calcium concentrations had no protective effects.	Dalziel <i>et al.</i> (1986)
2	pH=5.4; Ca=0.05 mmol/l; Al=0, 2, 4, 8 umol; semi-flowthrough exposure in synthetic water Fish: <i>Salmo trutta</i> .	Low pH down to 4.0 had little effect on sodium influx but increased efflux. Aluminium concentrations as low as 2 umol/l was sufficient to reduce sodium influx significantly at pH 4.0. Aluminium did not affect influx in fish at pH 5.4 but increasing aluminium concentrations tended to increase efflux at pH 5.4 and to lesser extent at pH 4.5. No effect of aluminium on efflux was apparent at pH 4.0.	Dalziel <i>et al.</i> (1987)
3	pH=4.1; Ca=38 and 190 uequiv/l; Al=350 ug /l; static exposure in synthetic water. Fish: <i>Salmo gairdneri</i> .	Low pH induced net loss of sodium, potassium, chloride ions. Addition of aluminium further significantly increased net losses in above ions. Loss of ions was branchial rather than renal. Increases in Hct but not in Hb and RBC, and decreases in osmolality were observed. Higher calcium concentrations in the media had no ameliorating effects.	Witters (1986)
4	pH=6.5-4.4; Ca=25 and 400 uequiv/l; Al=0, 111, 333 and 1000 ug/l; flow-through exposure in synthetic water for 11 d. Fish: <i>Salvelinus fontinalis</i> .	pH dependent reduction in influx in sodium, potassium, ammonium but but not in calcium ions observed. Exposure to aluminium further caused slight reductions in influx at low pH but, greatly stimulated efflux. Plasma concentrations of major ions decreased by acid/aluminium exposure. Fish at the highest aluminium concentration died within 1 d of exposure. Fish at 111 ug Al/l, however, recovered slightly. Higher calcium concentrations in the exposure media appeared to be protective against acid/aluminium toxicity.	Booth <i>et al.</i> (1988)

contd....

Ref. No.	Fish and Exposure Conditions	Observations	References
5	<p>Acclimation of fish at pH 5.2; Ca= 25 and 400 uequiv/l; Al=150 ug/l for 10 week. Challenge exposure at pH 4.8; Al=330 ug/l; flowthrough exposure in synthetic water for 40 min. Fish: <i>Salvelinus fontinalis</i></p>	<p>Acclimation of fish to pH 5.2 induced a decrease in sodium transport activity. Fish acclimated to acid/aluminium (150 ug/l) exhibited compensatory mechanism in transport activity in the gill. Acid/aluminium-acclimated fish showed greater resistance to challenge exposure than naive fish.</p>	<p>McDonald and Milligan (1988)</p>
6	<p>Acclimation of fish at pH 6.5 and 5.2; Ca=25 and 400 uequiv/l; Al=0, 75, 150 ug/l. Challenge exposure at pH 4.8; Al=333 ug /l; flowthrough exposure in synthetic water. Fish: <i>Salvelinus fontinalis</i></p>	<p>Acclimation of fish to pH 5.2 and elevated aluminium concentrations produced no significant changes in osmolality, plasma protein or Hb. Overall electrolytes were higher in aluminium exposed fish under high calcium conditions. Naive fish challenged with low pH and higher aluminium concentration showed large negative sodium netflux, depressed plasma sodium and chloride concentrations, increased Hct and mortality. Acid / aluminium but not pH alone (5.2) acclimation abolished such effects.</p>	<p>Wood et al. (1988b)</p>
7	<p>pH=5.5 and 4.0; Ca=0.35 mequiv/l; Al=6 u mol/l; recycled synthetic water exposure. Fish: <i>Salmo trutta</i>.</p>	<p>At pH 4.0 chloride efflux was not affected but influx reduced by 55%. At pH 5.5 influx was reduced by 62% while efflux increased by 67%. Potentiation of aluminium toxicity at pH 5.5.</p>	<p>Battram (1988)</p>
8	<p>pH= 6.5 and 4.5; Ca = 2 umol/l; Al= 6 umol/l semi-flowthrough exposure in synthetic water</p>	<p>At low pH calcium influx was inhibited and efflux was stimulated. Aluminium concentration had no additional effects over pH effect, except a slight, but insignificant, increase in efflux.</p>	<p>Reader and Morris (1988)</p>
9	<p>pH= 6.0-4.0; Ca=0.8-3.00 mg/l; Al= 190-531 ug/l; static exposure in tapwater. Fish: <i>Salmo trutta</i>.</p>	<p>Venous blood of brown trout exposed to aluminium was analyzed for plasma electrolyte, blood pH, oxygen, and carbondioxide tension. Exposure to 900 ug Al/l aluminium caused rapid loss in plasma sodium and chloride ion levels. Maximum response to aluminium observed at pH 5.0. Responses at pH 4.5 and 4.3 were comparatively small. No significant effect of aluminium could be detected at pH 6.0. Further experiment with 190 ug Al/l at pH 5.0 also proved to be toxic. Blood oxygen tension decreased while blood carbondioxide and pH were unaffected. Low aluminium level ameliorated acid toxicity at pH 4.0.</p>	<p>Muniz and Leivestad (1980)</p>

.....contd.

Ref. No.	Fish and Exposure Conditions	Observations	References
10	pH= 5.0; Al= 450 ug /l; static exposure Fish: <i>Savelinus fontinalis</i> ; <i>Salmo trutta</i> .	Substantial increases in oxygen consumption and ventilation rates were observed.	Rosseland (1980)
11	pH= 5.0; Al= 186-531 ugAl/l;static exposure in natural water. Fish: <i>Salmo trutta</i> .	Exposure to aluminium resulted in a loss of plasma chloride levels. More dramatic change in chloride ion (8 mmol/l/h) occurred at the highest aluminium concentration.	Rosseland and Skogheir (1982)
12	Static exposure in natural water at low pH and elevated aluminium concentration. Fish: <i>Salmo salar</i> , <i>Salmo trutta</i> , <i>Salmo gairdneri</i> , <i>Salvelinus fontinalis</i> .	Sensitivity of fish to aluminium exposure was compared by measuring plasma chloride levels in 4 species of fish. Plasma chloride levels decreased in all fish species, except brook trout. The result confirmed in differences in sensitivity to high aluminium and low pH combination exhibited by different fish species. Salmon was most sensitive, followed by rainbow trout and brown trout, brook trout being more resistant species.	Roseland and Skogheim (1984)
13	pH= 6.8-4.0; Ca= 0.8-6.0 mg/l; Al= 2 umol/l static exposure in tapwater. Fish: <i>Salmo gairdneri</i>	During 6-11 d exposure to aluminium blood respiratory, ionoregulatory and ventilatory parameters were measured. Death was due to hypoxia at pH 6.1, due to electrolyte loss at pH 4.5 and pH 4.0, at pH 5.5 there was a combination of the two mechanisms of toxicity. Organic acid ameliorated aluminium toxicity at pH 4.0 but not at pH 5.0.	Neville (1985)
14	pH= 5.0; Ca= 3.3 mmol/l; Al= 2 mg/l; static exposure in tapwater. Fish: <i>Salmo gairdneri</i> .	Aluminium caused no changes in plasma sodium and chloride levels but increased plasma potassium during 6 d exposure period. Dorsal aortic oxygen tension was greatly reduced, blood carbondioxide tension increased and oxygen uptake increased by 15%. Ventilation rate was doubled. Increases in Hct and RBC swelling also occurred. High High calcium concentration in the media probably protected fish from ionic loss but enhanced respiratory distress.	Maite (1986)

.....contd.

References

Observations

Ref. No. Fish and Exposure conditions

- | | | | |
|----|--|---|-------------------------|
| 15 | pH= 5.0; Ca= 1mg/l; Al= 200ug/l; static exposure in synthetic water.
Fish: <i>Salmo gairdneri</i> . | Acclimation of fish to pH 5.0 for 14 d did not protect the fish from toxic effect when challenged with aluminium. Deleterious effects of aluminium exposure were manifested in increases in blood Hct, Hb, RBC and a decline in plasma concentration of sodium chloride and plasma osmolality. | Witters et al. (1987) |
| 16 | pH= 4.8; Al= 240 ug/l; Field study.
Fish: <i>Salmo trutta</i> . | Exposure to aluminium resulted in a decline in plasma chloride ion and osmolality but caused an increase in blood Hct levels. | Muniz et al. (1987) |
| 17 | pH= 5.0; Ca= 3.5 mmol/l; Al= 2 mg/l; static exposure in tapwater for 6 d.
Fish: <i>Tinca tinca</i> . | Aluminium exposure caused immediate decrease in oxygen tension and increases in carbondioxide in blood. Hct and Hb also increased. Plasma chloride ion concentrations declined but bicarbonate, potassium and calcium ion levels increased. Changes in plasma ions were small compared to respiratory distress. Ambient high calcium concentration probably caused increased respiratory distress in aluminium-exposed fish. | Jensen and Weber (1987) |
| 18 | pH= 5.1-4.2; Al=0.27-0.37; Field experiment in a stream.
Fish: <i>Salmo trutta</i> . | Reduction in plasma sodium levels were observed at all pHs. Addition of aluminium alleviated this effect at pH 4.2 but exacerbated it at pH 4.8-5.1. Loss of plasma potassium concentrations were also observed. Ventilation rate increased at pH 4.8-5.1 with aluminium but less consistent at pH 4.2. | Omreod et al (1987) |
| 19 | pH= 4.8; Ca= 25 uequiv/l; Al= 112 ug/l; flow through exposure in synthetic media.
Fish: <i>Salmo gairdneri</i> . | Low pH caused moderate ionoregulatory disturbances. Addition of aluminium further caused 100% mortality within 72 h. Loss in plasma ion levels, hyperglycemia, lactate accumulation, increases in Hct, RBC swelling and greatly elevated plasma cortisol concentrations were observed. | Goss and Wood (1988) |
| 20 | pH= 5.2 and 4.8; Ca= 45 and 410 uequiv/l; Al= 105 ug/l; flow-through exposure in synthetic water for 72 h.
Fish: <i>Salmo gairdneri</i> . | Two toxic mechanisms were seen; (a) ionoregulatory toxicity, caused by aluminium at pH at pH 5.2 and 4.8, and by acidity alone at pH 4.4.; (b) respiratory toxicity, caused solely by aluminium and was greatest at higher pH. Ionoregulatory toxicity involved decreases in plasma sodium and chloride levels and increases in plasma potassium. Respiratory disturbances included reduced blood oxygen tension, elevated carbondioxide tension and increases in blood lactate. High calcium level in the media reduced ionoregulatory disturbances due to acidity alone but not to those due to aluminium at higher pH. | Playle et al. (1989) |

.....contd.

Ref. No.	Fish and Exposure Conditions	observations	References
21	<p>Acclimation of fish for 10 week at pH 6.5 and 5.2; Ca= 25 and 400 Uequiv/l; Al= 150 Ug/l; Challenge exposure at pH 4.8 and 333 ug Al/l. Flow-through exposure in synthetic media. Fish: <i>Salvelinus fontinalis</i>.</p>	<p>Fish acclimated in acid/aluminium conditions did not exhibit any respiratory and other physiological disturbances. Naive fish challenged with pH 4.8 and higher aluminium concentration showed ionoregulatory, acid-base, respiratory, fluid volume, haematological and other physiological disturbances. Acid/aluminium acclimated fish showed greater resistance than acid alone acclimated fish when challenged. Thus acclimation was to aluminium rather than to acidity itself. Higher calcium in the exposure media delayed but did not prevent toxic effects. Cortisol levels were increased by aluminium exposure.</p>	<p>Wood et al. (1988c)</p>
22	<p>pH 4.8 and 4.4; Ca= 25 and 400 uequiv/l; Al= 333 ug/l; flow-through exposure in synthetic water. Fish : <i>Salvelinus fontinalis</i>.</p>	<p>Fish exposed to 4.8 under low calcium conditions showed negligible physiological disturbances. Addition of aluminium to the same media resulted in fish mortality preceded by marked decreases of plasma sodium and chloride ions; moderate disturbances in blood gases but no blood acidosis. Plasma glucose level increased greatly. Similar exposure under high calcium conditions caused similar mortality but smaller ionic disturbances and respiratory acidosis. pH 4.4 also induced mortality and accompanying marked ionic disturbances, metabolic acidosis but little changes in blood gases. Addition of aluminium increased mortality with smaller ionic disturbances but greater respiratory disturbances.</p>	<p>Wood et al. (1988a)</p>
23	<p>pH= 4.8; Ca= 400 uequiv/l; Al= 333 ug/l. Synthetic water exposure. Fish: <i>Salvelinus fontinalis</i>.</p>	<p>Acid/aluminium-induced increases in ventilation and cough rates in fish but no changes in in blood oxygen tension and oxygen consumption were observed.</p>	<p>Walker et al. (1988)</p>
24	<p>Acclimation of fish at pH 5.0 for 7 d; exposure at pH 4.7 and 180 ug Al/l with or without 10 mg/l humic substances; flow-through exposure in synthetic water. Fish: <i>Onchorhynchus mykiss</i>.</p>	<p>pH acclimated fish when exposed to aluminium caused mortality accompanied by 25% reduction in plasma concentrations of sodium chloride and doubling of Hct value during a 10 d exposure period. Presence of humic substances in the media ameliorated these toxic effects.</p>	<p>Witters et al. (1990)</p>
25	<p>pH= 65 and 5.0; Ca= 0.5 and 7.5 mg/l; flow-through exposure. Fish: <i>Salmo fontinalis</i>.</p>	<p>Potential of toxic effect at low pH and low calcium concentrations. Plasma sodium level was depressed; spawning surge in plasma calcium did not occur; plasma oestradiol and vitellogenesis were reduced by aluminium. Failure in reproductive success was correlated with osmoregulatory disturbances in fish caused by aluminium.</p>	<p>Mount et al.(1988a)</p>

.....contd.

Ref. No.	Fish and Exposure Conditions	Observations	References
26	pH= 5.0; Al= 200 ug/l; Ca= not known. Static exposure in tap water. Fish: <i>Salmo salar</i> .	Exposure to the said conditions reduced the activity of carbonic anhydrase and Na/K-ATPase enzymes in the gills by 25-40% of control (maintained at pH 5.0) levels.	Staurnes et al. (1984)
27	pH= 5.0; Ca= 28 umol/l; Al= 60 ug/l; Flow-through exposure in synthetic media. Fish: <i>Oncorhynchus mykiss</i>	A 10-fold increase in plasma catecholamine levels accompanied by elevated cortisol levels were observed under said exposure conditions. Simultaneous decreases in plasma sodium concentrations and blood oxygen tension were also recorded.	Witters et al. (1991)
28	pH= 5.4, 4.8 and 4.5; Ca= 10-50 umol/l; Al= 2-8 umol/l; flow-through exposure in synthetic water. Fish: <i>Salmo trutta</i> (yolk-sac fry).	During a 30 d exposure, aluminium concentrations of 2-8 umol/l impaired growth, survival, gross development and net uptake of calcium, potassium, sodium, and also impaired calcium deposition in skeleton. These effects were more severe at calcium concentration 10 umol/l and some more severe at pH 5.4. Low calcium concentration alone also affected calcium deposition in skeleton.	Reader et al. (1988)
29	pH= 6.5 and 4.5; Ca= 20 umol/l; Al= 6000 nmol/l; and also in mixture with other metals.; Flow-through exposure. Fish: <i>Salmo trutta</i> (yolk-sac fry).	At low pH, in the absence of metal, whole body net uptake of sodium, potassium and calcium deposition were impaired with only 10% mortality. At pH 4.5 aluminium individually and also in mixture with other trace metals caused 87-100% mortality. At low pH addition of aluminium further impaired whole body net calcium and potassium uptake.	Reader et al. (1989)
30	pH= 6.5-4.0; Ca= 0.5-8.0 mg/l; Al= 0-1000 ug/l; flow-through exposure in synthetic media Fish: <i>Salvelinus fontinalis</i> (fertilization to swim-up fry).	Lower calcium concentrations, and higher aluminium concentrations in acidic pH individually and in combination caused negative influence on whole body sodium, potassium chloride and calcium ion balance.	Wood et al. (1990)

acid/aluminium stress, O₂ consumption in stressed fish, in general, increased (ref. no. 10, 12, 14, 23). Consistent with this effect, ventilatory responses in fish are also increased by acid/aluminium exposures (ref. no. 10, 12, 14, 23). Blood acid-base status has been monitored by a few workers and blood pH was reported to be reduced by acid/aluminium exposures (ref. no. 9, 13, 19, 21, 22).

In general, increases in blood haematocrit (ref. no. 3, 6, 10, 14-17, 20, 24) and blood haemoglobin concentrations (ref. no. 13-15, 17-20) have often been reported from fish exposed to acid/aluminium conditions. Similarly, acid/aluminium stress has been shown to increase erythrocyte number in blood (ref. no. 14, 15) as well as to induce erythrocyte swelling (ref. no. 14, 19, 20).

1.4.1.4. Effects on Other Biochemical Parameters

Plasma concentrations of cortisol (ref. no. 20, 21, 27) and catecholamines (ref. no. 27 and also observed by Goss, Playle and others; unpublished results quoted in Playle *et al.*; 1989), considered as primary stress responses, have been reported to be greatly elevated by acid/aluminium exposures. Similar changes in plasma glucose (ref. no. 20, 21, 27) and lactate (ref. no. 17-20, 22) concentrations have also been reported from fish exposed to acid/aluminium. The changes in plasma protein concentrations were not clear-cut but, in general, tended to be increased under acid/aluminium conditions (ref. no. 6, 20). Acid/aluminium has been shown to inhibit Na⁺/K⁺-ATPase and carbonic anhydrase activities in fish gills (ref. no. 25).

1.4.2. Histopathology

Histological changes in acid/aluminium-exposed fish have been a subject of a few studies. Several early investigators indicated gross abnormalities in fish gills acutely exposed to acid/aluminium (Muniz and Leivestad, 1980; Schofield and Tronjar, 1980). These abnormalities included mucus clogging and lamellar fusion in gills. Based on

histological observations under light microscope, severe gill lesions including lamellar thickening, fusion of secondary lamellae, epithelial lifting and cell necrosis, were described by Saleh (1986) in acutely exposed tilapia, *Oreochromis aureus*, under acid/aluminium conditions at different pH levels. Subsequently, Karlsson-Norrgrén *et al.*, (1986b) examined brown trout, *S. trutta*, gill tissues after exposure to different aluminium concentrations (50, 200, 500 $\mu\text{g l}^{-1}$) at pH 5.5 and 7.0 for 3 to 6 weeks under static exposure in tap water conditions. The pathology observed by the authors included swelling and fusion of secondary lamellae, intercellular vacuolation, epithelial hyperplasia and proliferation of chloride cells. While there were no noticeable changes in gills of fish at 50 $\mu\text{g Al l}^{-1}$, the pathological changes observed by the authors at aluminium concentration of 500 $\mu\text{g l}^{-1}$ were severe. Addition of humus substances in the exposure media reduced the adverse effects of aluminium exposure. However, the observations were limited to a few selected lesion types.

Youson and Neville (1987), using transmission electron microscopy, reported cellular changes in chloride cells in rainbow trout exposed to different aluminium concentrations under tap water exposure conditions.

In rainbow trout, *S. gairdneri*, subjected to 5, 10, 20 $\mu\text{mol Al l}^{-1}$ at pH 4.7 and 5.2, Evans *et al.* (1988) also found primary epithelial hyperplasia, chloride cell proliferation and increased blood-water-diffusion distance. Pathological changes were more severe with aluminium at pH 5.2 than at pH 4.7. A low level of aluminium in the exposure media protected the fish from the adverse effects of low pH. This experiment was also conducted in tap water under static exposure conditions.

Jago *et al.* (1987) reported abnormalities in gills of sac fry of Atlantic salmon, *S. salar*, hatched and maintained at pH 5.5 and different aluminium concentrations (0, 38, 75, 150 and 300 $\mu\text{g l}^{-1}$) for a period of 60 days. These abnormalities included poorly

developed or absence of secondary lamellae, fused primary lamellae and proliferation of chloride and epithelial cells. Using transmission microscopy this study described degenerative changes in chloride cells. However, the above changes were evident in fish exposed to aluminium concentrations $\geq 75 \mu\text{g l}^{-1}$. Acid alone exposure produced none of the above changes.

Morphometric changes in gill secondary lamellae were investigated by Tietge *et al.* (1988) in brook trout, *S. fontinalis*, exposed to an aluminium concentration of $393 \mu\text{g Al l}^{-1}$ at pH 6.6 to 4.3 for a period of 143 days. Acid/aluminium exposure resulted in increased diffusion distance, white blood cell infiltration and a dramatic increase in lamellar dense cells. While low pH alone induced a significant increase in chloride cell number, aluminium had no additional effect on this cell type number. The authors suggested that high aluminium concentration probably caused degeneration in chloride cells resulting in a decrease in the cell number.

1.4.3. Effects on Egg Hatchability, Growth and Reproduction

Cleveland *et al.* (1986) investigated the mortality, growth and behavioural responses in brook trout as a function of developmental stages. Eyed eggs and young brook trout were exposed to low pH (4.5, 5.5 and 7.2) with or without aluminium ($300 \mu\text{g l}^{-1}$) for 30 days. Growth was retarded and mortality increased by low pH and/or by aluminium concentration. Adverse effects generally increased as pH decreased from 7.2 to 4.5 and potentiation of effects by aluminium occurred at pHs of 5.5 to 7.2. However, under similar exposure conditions (but in soft water), Hunn *et al.* (1987) found that aluminium significantly reduced embryo mortality in brook trout at pH 4.5 but had no effect at higher pHs.

Sadler and Lynam (1987) exposed yearling brown trout to various aluminium concentrations ($0-3.7 \mu\text{mol l}^{-1}$) over a pH range 4.3-6.5 in a flow-through exposure

system using synthetic water media. Low pH produced little effect on growth or survival except at the lowest pH (4.3). At pH less than 5.5, concentrations of total aluminium in excess of $1 \mu\text{mol l}^{-1}$ were found to retard growth. The effects of aluminium were reduced at pH above levels 5.5. The authors suggested that $\text{Al}(\text{OH})_3$ was the most toxic moiety. In a further experiment, Sadler and Lynam (1988) demonstrated the protective effects of ambient calcium concentrations on acid and aluminium-induced changes in growth and mortality. They exposed yearling brown trout at pH 5.2 to various concentrations of calcium ($4\text{-}400 \mu\text{mol l}^{-1}$) and aluminium ($0\text{-}3 \mu\text{mol l}^{-1}$). In general, higher mortality and lower growth rates were found at higher aluminium concentrations, with these effects being reduced at higher calcium concentrations. Segner *et al.* (1988) also recorded a significant growth depression in young brown trout exposed to pH 5.0 at $230 \mu\text{g Al l}^{-1}$. Similar growth reductions were also observed by Reader *et al.* (1988; 1989) in brown trout yolk-sac fry exposed to acid/aluminium conditions (see ref. no. 28 and 29; Table-1.1.).

In a long-term experiment (147 d), Mount *et al.* (1988b) investigated the survival, growth, fecundity and progeny survival of brook trout exposed to concentrations of pH, aluminium, and calcium. At low pH (4.42-5.03) survival and growth were reduced by aluminium concentrations ($486 \mu\text{g l}^{-1}$) and low calcium concentrations (0.5 mg l^{-1}). Fecundity was also reduced under these conditions but it was thought to be mediated through reduced growth. Progeny survival was not impaired by acid/aluminium exposure.

McCormick *et al.* (1989) also reported the adverse effects of acid/aluminium exposure on spawning success, embryogenesis and early larval survival of brook trout, *S. fontinalis*. At higher pH (7.5) low levels of aluminium ($15\text{-}30 \mu\text{g Al l}^{-1}$) appeared to be protective against the adverse effects of low calcium exposure on spawning.

Ingersoll *et al.* (1990a) exposed various life stages of brook trout, *S. fontinalis*

(fertilized eggs through swim-up fry), to a matrix of 84 combinations of pH (6.5-4.0), calcium (0.0-8.0 mg l⁻¹) and aluminium (0-1000 µg l⁻¹). Fertilization and hatching rates were affected by pH ≤ 5.2. Survival of swim-up fry was affected at pH ≤ 4.4-4.0. Lower aluminium concentrations ≤ 111 µg l⁻¹ reduced adverse effects of low pH. Higher aluminium concentrations, however, deleteriously affected all life stages of brook trout. Sensitivity to aluminium gradually increased with age.

Two strains of brook trout were exposed to 14 combinations of pH (6.5-4.3), aluminium (6-665 µg l⁻¹) and calcium (0.6-1.9 mg l⁻¹) by Ingersoll *et al.* (1990b). Survival and growth of both strains were affected similarly by pH, calcium and aluminium exposure. Survival was reduced by monomeric aluminium concentrations of 29 µg l⁻¹ at pH 5.2 and ≥ 228 µg l⁻¹ at pH 4.4 and 4.8. Growth was reduced by pH ≤ 4.8 and aluminium concentrations ≥ 34 µg l⁻¹.

1.5. Mechanisms of Acid/Aluminium Toxicity

The present understanding of aluminium toxicity to fish is based largely on the symptoms related to exposure to the toxicant and is still incompletely understood. However, in general, the mechanisms of aluminium toxicity appear in many respects to resemble that of H⁺ toxicity (see Wood and McDonald, 1987; Booth *et al.*, 1988). Aluminium accumulation/binding in/or on the gills and its effects on the gill structures and functions are thought to be the main cause of aluminium toxicity.

Two general, but mutually distinct, theories have been suggested of the way in which aluminium acts on the gills, one based on solubility and the other based on aluminium speciation. The first, as suggested by Schofield and Tronjar, (1980) (also see Wood and McDonald, 1987), views aluminium toxicity as a function of transformation of soluble monomeric aluminium species into either polymers/ or precipitates at the gill surface. This transformation causes irritation and induces inflammatory response in gill tissues.

Rapid aluminium precipitation at the gill surface would either require the interlamellar water to be heavily over-saturated with respect to amorphous $\text{Al}(\text{OH})_3$, or aluminium at the gill surface, perhaps, bound to anionic sites, to act as nucleation sites for the induced precipitation of aluminium. The second mechanism (see Booth *et al.*, 1988) is based on differences in toxicity amongst the aluminium species. In this case the suggestion is that aluminium species vary in terms of reactivity with surface binding. Therefore, aluminium toxicity depends on competition between aluminium species, hydrogen ions and other cations for binding /chelation/adsorption at the gill surface. The positive charge on the aluminium species found in acid solution could induce the association of aluminium with anionic sites on the gill surface, anionic sites that may be integral to the gill physiology and biochemistry.

The two toxic mechanisms, as described above, are probably not mutually exclusive. It is likely that both mechanisms are involved in aluminium toxicity and that their relative importance are attributable to the prevailing water quality (see Booth *et al.*, 1988). Under some circumstances, both may be equally active in producing gill damage, whereas under others, one may be predominant over the other.

Irrespective of which of the above mechanisms is involved, aluminium causes gill damage (Schofield and Tronjar, 1980; Karlsson-Norrgren *et al.*, 1986b; Evans *et al.*, 1988; Tietge *et al.*, 1988) and can alter gill functions, particularly with regard to gill permeability and gill enzyme activity (Staurnes *et al.*, 1984a). These cause imbalances in ion fluxes across the gills, particularly that of sodium and chloride (Dalziel *et al.*, 1986; 1987; McDonald and Milligan, 1988; Booth *et al.*, 1988; Battram, 1988), resulting in a rapid loss of plasma sodium and chloride ions. Death probably results from the concomitant effects of plasma ionodilution (Muniz and Leievestad, 1980; Neville, 1985; Booth *et al.*, 1988; Wood *et al.*, 1988a), probably through disturbances in fluid volume distribution, cardiac function, and impaired enzyme and nerve functions.

At the same time, mucus production, the build up of aluminium complexes on the gill surface, oedema, swelling of the gill epithelium, may all serve to increase water-blood diffusion distance for oxygen and carbon dioxide. Thus, acid/aluminium stress also involves respiratory blockade as a second mechanism of toxicity in addition to ionoregulatory failure (Muniz and Leivestad, 1980; Neville, 1985; Malte, 1986; Wood *et al.*, 1988a). A contributory factor in fish death may also involve imbalances in acid-base regulation. Such disturbances have been suggested as arising from respiratory as well as metabolic acidosis (see Table-1.1.).

Sublethal effects are manifested in gill damage, retarded growth, reproductive failure (see Section 1.4.). The degree and manifestation of the above toxic effects are dependent on the prevailing water quality.

1.6. Influence of External Calcium Concentrations on Gill Structure and Functions

One of the main aims of the present study was to investigate the ameliorative effects of external calcium on aluminium toxicity. To understand this it is of value to first examine the normal interactions of calcium with gill function. The gill surface has a net negative charge because of a variety of anionic ligands. The surface ligands of fish gills probably consist of the following: sialic acid residues of mucus and membrane glycoproteins, carboxyl groups of membrane glycolipids and various polyelectrolytes of intercellular cement; hyaluronic acid, heparin and chondroitin sulphate with carboxyl and phosphate groups (Oschman, 1978). The common feature of these ligands is the predominance of oxygen as a donor (Oschman, *ibid*). In neutral waters external calcium probably exerts most of its effects being bound to gills. The gill binding of any cation, including calcium, probably occurs through the anionic ligands (McDonald, 1983b). Divalent calcium ions can reduce the hydration of organic molecules as well as forming cross-links with surface ligand molecules to form more condensed structures, thereby maintaining the stability and integrity of the apical membrane of the transporting cells

(Potts and McWilliams, 1989; McDonald *et al.*, 1989, for reviews). In addition, calcium ions are probably bound to two separate sites, involved in ionic regulation: to the apical sodium channels and to the paracellular tight junctions (McDonald, 1983b). Binding on the inner surface of these sites calcium may, thus, increase the positivity of the pores and may selectively reduce the permeability of the ions (McWilliams and Potts, 1978). Therefore, it appears that any metal interfering with calcium at the gill surface may alter the ionic and osmotic regulation capability of gills.

External calcium concentration has been shown to have marked effects on ion fluxes (Na^+ , Cl^- , Ca^{2+}) both in freshwater and marine fish (Cuthbert and Maetz, 1972; Eddy, 1975; Perry and Wood, 1985; Flik *et al.*, 1986). In the above studies, in general, removal of calcium from the external medium increased both influx and efflux across the gills. It has been interpreted that lower concentrations of calcium in the medium stimulated efflux and the observed increases in influx were probably a compensatory response to increased efflux. Investigations on the effects of external calcium concentration on transepithelial potential (T.E.P.) measurements have indicated the way in which calcium effects ionic efflux. Kerstetter *et al.*, (1970) and Eddy (1975) found that the presence of calcium in the experimental media produced a positive shift in the polarity of the T.E.P. in rainbow trout, *Salmo gairdneri*. McWilliams and Potts (1978) also found that at pH 7.0 in calcium free medium the T.E.P. in brown trout, *S. trutta*, was -16mv. Addition of calcium to the medium produced a reversible shift in potential in a positive direction and with a concentration of 80 mg Ca l^{-1} the T.E.P. was a few millivolts positive. Further increases in calcium concentration produced no significant change in potential. In calcium-free medium the permeability ratio $\text{Na/Cl} = 1.7$. As calcium was added to the external medium the ratio approached unity and at calcium concentrations greater than 200 mg l^{-1} the ratio became less than 1.0, indicating that chloride ion were diffusing out more rapidly than sodium, (i.e., the permeability of gills to sodium ions had been reduced) and as a result the T.E.P. was slightly in a positive

direction.

1.7. Regulation of Ionic Balance in Fish

Freshwater fish have body ionic concentrations which are considerably higher than that of the external medium. Consequently, there is a tendency for body ions to diffuse out to the external medium. Concomitantly, there is a continuous inflow of water into the fish, which is excreted in the form of a copious dilute urine. The kidneys re-absorb many of the ions but inevitably some are lost. To make good this loss of ions, freshwater fish have developed active uptake mechanisms for major body ions against a considerable concentration gradient. Any interference in this dynamic process may lead to an imbalance in ionic concentrations in the fish body.

Krogh (1939) was the first to demonstrate that fish can extract sodium and chloride ions independently from the freshwater environment and subsequent studies (Kerstetter *et al.*, 1970; Payan *et al.*, 1975; Payan, 1978) clearly indicate that the branchial epithelium is the site of ionic uptake. Krogh (*ibid*) also suggested that approximate electroneutrality was maintained across the epithelium by the coupled exchange of NH_4^+ for Na^+ and HCO_3^- for Cl^- . Clear evidence supporting this proposition came from the studies of Maetz and Garcia-Romeu (1964) who demonstrated, using radioactive isotopes, that injection of either NH_4 or HCO_3 into the peritoneal fluids of the goldfish, *Carassius auratus*, stimulated uptake of Na^+ and Cl^- , respectively, while addition of the ions to the external media inhibited uptake of both of the above ions. The proposal for a $\text{Cl}^-/\text{HCO}_3^-$ exchange system was further corroborated by studies of Kirschner *et al.* (1973). By using an isolated double-perfused trout head Payan *et al.* (1975) and Payan (1978) have demonstrated that Na^+ uptake in fishes is associated with NH_4^+ efflux. There are also indications that Na^+ uptake may be coupled with H^+ efflux. Kerstetter *et al.* (1970) found that in rainbow trout the NH_4^+ efflux was unaffected by substantial changes in external sodium concentrations while there seemed to be a correlation

between the rate of sodium uptake and the acidification of the external medium. Further evidence of this proposal came from Cuthbert *et al.* (1979). However, Maetz (1973) calculated that Na^+ uptake could best be correlated with the sum of NH_4^+ and H^+ efflux. Therefore, it appears that both exchange mechanisms operate within the freshwater teleost branchial epithelium. The involvement of carbonic anhydrase to promote H^+ and HCO_3^- , necessary for the above exchange processes, has been demonstrated using the anhydrase inhibitor acetazolamide (Kerstetter *et al.*, 1970; Payan *et al.*, 1975). The above exchange mechanisms are thought to operate at the apical border of the ion transporting cell (Evans, 1980a). Several authors have envisaged an electroneutral antiport system located in the apical membrane of the chloride cell driven by basolateral Na^+/K^+ -ATPase (Kerstetter *et al.*, 1970; Maetz 1974). In recent years, however, several other ATPase enzymes (Na^+/H^+ -ATPase, $\text{Na}^+/\text{NH}_4^+$ -ATPase) have been described in freshwater fish (Balm *et al.*, 1988; also see review by DeRenzis and Bomancin, 1984). However, the evidence is not convincing. The basolateral movement of sodium occurs through Na^+/K^+ exchange mechanism (Richards and Fromm, 1970; and see also review by Evans, 1980b) and mediated by Na^+/K^+ -ATPase. The evidence for the involvement of Na^+/K^+ -ATPase in branchial sodium regulation is now fairly extensive (Kerstetter *et al.*, 1970; Jampol and Epstein, 1970; Maetz, 1971; 1974; Silva *et al.*, 1977; Moon, 1978; Watson and Beamish, 1980; Dange, 1985).

The active uptake of calcium through gills has also been demonstrated in a number of studies (Perry and Wood, 1985; Flik *et al.*, 1985a; Flik *et al.*, 1986;1986a; Reader and Morris, 1988). Flik *et al.*(1985b) proposed a model for calcium uptake across fish gills. The model suggests that uptake of calcium through the apical membrane is passive along an electrochemical gradient but basolateral transportation is an energy requiring-process and is mediated through a transport enzyme. It is also fairly well established that a calcium dependent ATPase enzyme (Ca^{2+} -ATPase) is associated with active uptake of calcium ions across the cell membrane (Ma *et al.*,1974; Burdick *et al.*, 1976;

Fenwick, 1976; Shephard and Simkiss, 1978; Moon, 1978; Watson and Beamish, 1980; Bansal *et al.*, 1985).

The actual cell type in the gill involved in ionic uptake is still open to debate. While functional gill models suggest that the chloride cells are the most likely sites of active ionic uptake in freshwater fish (review: Evans *et al.*, 1982), other investigators believe that lamellar respiratory cells are the important transporting cells (Girard and Payan, 1980; Payan and Girard, 1984). However, more recent studies point strongly to the chloride cells as the major sites of active uptake (Perry and Wood, 1985; Avella *et al.*; 1987). The basolateral localization of Na^+/K^+ -ATPase in the chloride cells strongly suggests the involvement of chloride cells in ionic uptake (Hootman and Philpott, 1979)

1.8. Problems and Scope in Physiological Investigations in Fish under Acid/Aluminium Conditions

It is clear that aluminium is one of the most important pollutants in acidic environments. Its adverse effects on fish population are now well recognized. The ability of this metal to induce physiological problems in fish has come to light in recent years. Disruption of branchial ionoregulatory and respiratory mechanisms have been suggested to be the main toxic syndromes in aluminium toxicity. Presently, the evidence supporting these conclusions appears to be overwhelming, although many findings remain contradictory and the exact mode of its toxic action under diverse environmental conditions is still poorly understood.

Of importance is the role of ambient calcium concentrations on the physiological effects of aluminium in fish under acidic conditions. The protective effects of ambient calcium concentrations is well established in the toxicology literature as reducing the toxicity of a number of aquatic contaminants (Alabaster and Lloyd, 1980; Sprague, 1985; McDonald *et al.*, 1989). The physiological bases for this protection is discussed above

(Section 1.6.) in detail. For acid alone exposure, the ameliorative effects of external calcium on fish physiology, on ionic balance and haematology in particular, have been extensively studied and are well documented. However, when the present study commenced there were very few studies concerned with ambient calcium concentrations and their ameliorative effects on physiology of acid/aluminium-exposed fish (Dalziel *et al.*, 1986; Witters, 1986). These authors, however, could not demonstrate any significant effect of ambient calcium concentration on ionoregulation in fish exposed to 0.05 mmol l⁻¹ calcium compared with fish held in 0.01 mmol Ca l⁻¹. It was argued that the highest calcium concentrations employed in their studies were probably insufficient to induce any measurable effect during short-term experiments. Subsequent to and contemporary with the present work, several researchers did use significantly higher concentrations of calcium. However, the results are conflicting (see Section 1.4.). It appears from the literature that the elucidation of such an action of calcium may depend not only on the concentrations of calcium but also on the levels of aluminium and duration of the experiment. Therefore, the use of a number of aluminium and calcium concentrations is necessary to characterize the effects of external calcium concentrations on the physiological effects of aluminium in fish.

Studies concerned with ionoregulation (Section 1.4.1.1.) have convincingly demonstrated the effects of acid/aluminium exposure on ion fluxes. Several have reported inhibitory action of aluminium on ion influx rates. However, the underlying mechanisms remain poorly understood. Effects of acid/aluminium exposure on ion transport enzymes have rarely been properly assessed. Similarly, a large number of studies have measured plasma ion concentrations (Section 1.4.1.2.) in an attempt to assess the stress response in fish and/or to correlate them with the observed changes in ion influx rates in fish under acid/aluminium stress. It is well known that tissue ions may be reabsorbed in the face of a decline in plasma ion concentrations and may compensate for the loss of the latter ions. Therefore, on the basis of plasma ion measurements and without the

concomitant knowledge of tissue ion concentrations, the meaningful interpretation of ionic status of fish or assessment of stress response in fish is not only difficult but also may be misleading. However, no attempt was made to measure the ion concentrations in different tissue compartments of acid/aluminium exposed fish. Since gills are regarded as the target organ for aluminium toxicity, it is necessary to describe changes in structure and ultrastructure in gill tissue in order to fully explain the ionic imbalance caused by aluminium. Although a number of studies have examined the acid/aluminium induced changes in gill tissue (Section 1.4.2.), detailed histological knowledge of gill alteration has yet to emerge.

It is now well documented, through toxicological and physiological investigations, that the effects of many chemical pollutants, especially that of pH and heavy metals, are influenced by variety of water quality parameters (Alabaster and Lloyd, 1980; Spry *et al.*, 1981). It also appears from the literature that the majority of early works investigating the physiological effects of aluminium on fish were carried out using tap water in static exposure conditions (Muniz and Leivestad, 1980; Rosseland and Skogheim, 1982; 1984; Neville, 1985; Malte, 1986; Jensen and Weber, 1987, for examples). Therefore, the results from those experiments with unknown or imprecisely known water composition appear to be of limited use, because not only is the exact effect of the toxicant difficult to establish but also comparisons between studies are often impossible.

It is evident from the foregoing literature review that studies concerned with physiological effects of aluminium on fish are confined to cold water species and salmonids in particular. However, several studies have indicated that sensitivity in physiological responses to aluminium exposures can vary among different species (Rosseland, 1984; see also Table 1.1.). Although acid/aluminium conditions prevail in many areas of tropical and subtropical countries, so far no attempt has been made to

study the physiological effects of aluminium on any warm water fish. However, a few mortality trials have indicated that aluminium is also toxic to warm water fish (Murungi and Robinson, 1987; Phillips and Saleh, 1987) and the latter authors emphasized the need for further studies on tropical and subtropical fish species. It is, thus, necessary to evaluate the physiological response among warm water fishes before any generalization of aluminium toxicity can be made.

1.9. Objectives of the Present Study

In addition to evaluating the stress response of a warm water fish species to aluminium, it was apparent at the beginning of this project that much work was still required on the physiological response to acid/aluminium exposure in order to understand the toxic mode of aluminium, particularly with regard to ionic regulation. These continued to form the core of the project, despite the fact that it coincided with a period of active research into physiological responses to aluminium, in which time a large number of papers were published (Section 1.4.). Literature review clearly indicated that investigations on blood parameters would be of value. However, the gaps in knowledge, as outlined in the previous section, suggest that measurements of electrolyte levels in tissue compartments in conjunction with plasma ion measurements would be required in order to evaluate ionic status in stressed fish. Similarly, measurements of ion transport enzyme activity in gills of acid/aluminium exposed fish would help in an understanding of the biochemical basis of uptake inhibition observed by previous workers. Therefore, an attempt was made to study both these aspects of physiology under acid/aluminium exposures. These studies were also combined with structural and ultrastructural investigations of gills in order to assess whether any changes in ionic status could be explained by gill alterations and also whether that changes in cellular architecture could provide an insight into the mechanisms of aluminium toxicity.

A further objective of this study was to investigate the influence of external calcium

on physiology in acid/aluminium-stressed fish. Different combinations of aluminium and calcium concentrations were used to assess whether the protective action of calcium is a function of interaction between concentrations of both the ions. Since water quality parameters are important determining factors in acid/aluminium toxicity studies, a priority of the present study was to stringently control water quality parameters. It was, therefore, decided to conduct the experimental trials under flow-through exposure conditions in synthetic water media of precisely known composition.

CHAPTER 2
GENERAL MATERIALS AND METHODS

The materials and methods common to all experiments are presented in this chapter, whereas specific aspects of materials and methods applicable to individual experiments are detailed in the appropriate chapters.

2.1. The Fish. Source and Maintenance of Fish Stock

Male Nile tilapia, *Oreochromis niloticus* (L.), were used in this study. Fish weight varied between 57.6 and 86.2g and were 5-6 months old. They were bred from a genetically homogeneous stock (McAndrew and Majumdar, 1983) in the Tropical Aquarium, Institute of Aquaculture and were raised to the required size in a recirculating system in the above facility. Preliminary trials showed that certain blood parameters vary between male and female fish, particularly fluctuating among females, therefore, only male fish were used. The fish were sexed by hand and only the experimental male fish were held separately for at least one month prior to the experiments.

The fish holding system consisted of several tanks which were fed individually with a continuous flow of water from a header tank. Adequate water flow and air diffusion ensured an adequate oxygen supply. The system used biofilters for controlling ammonia and nitrite. In addition, the system was cleaned and fresh water added periodically. The water was thermostatically regulated to maintain a temperature of 27°C. A 12:12 light/dark regime was maintained using electronically preset aquarium lights.

For toxicological investigations, pre-exposure water quality is probably an important aspect to consider. Therefore, certain water quality parameters of the holding system were monitored at intervals and a summary of these is given in Appendix-1.

2.2. The Experimental System and the System Protocol

As has been indicated in chapter 1, a static exposure system was unsuitable for the

present study and thus it was necessary to build a flow-through exposure system. Again, since one of the aims of this study was to use synthetic water (Chapter 1), a flow-through exposure system having provision for multistage treatment of tap water was built and standardized. The schematic representation of the system is presented in Fig. 2.1. Tap water was passed through a membrane filter (MF) having 1 μm pore size and then through an activated carbon filter (CF) to remove suspended solids including trace organics and free chlorine, respectively. The filtered water was then passed through ion exchange resin columns (C1-C2) for deionization and the outflow was collected in a bottom reservoir (BR). The water was then pumped up into a primary header tank (H1) of 100 l capacity employing an airlift pump (ALP) entirely constructed from PVC pipes and accessories. This header tank had an outflow of excess water back into the bottom reservoir and thus maintained a constant head in all header tanks. Water then entered into a second header tank (H2) and there it received salts by regulated dosing to maintain the ionic composition of the experimental water. Water then flowed into a third header tank (H3) where the pH of the water was adjusted to a desired level. Similarly, another outlet from the second header tank led into two exposure tanks. Therefore, water of approximately neutral pH could be supplied into those two tanks, when necessary. From the third header tank, water was distributed into fish exposure tanks (T1-T8) through a water delivery system (DP). Before entry into the tanks, the water was percolated with toxicant in mixing chambers (mc1-mc8).

The following discussion will provide some of the individual aspects in detail and the rationale behind them. The associated problems are also discussed.

2.2.1. Deionization of Water

Deionization was achieved by passing the outflow water from the carbon filter through ion exchange resin columns (see Fig.2.1). For the purpose two deionization units were built and maintained.

Each unit consisted of two PVC pipes (137 cm long and 20 cm in diameter) fitted with

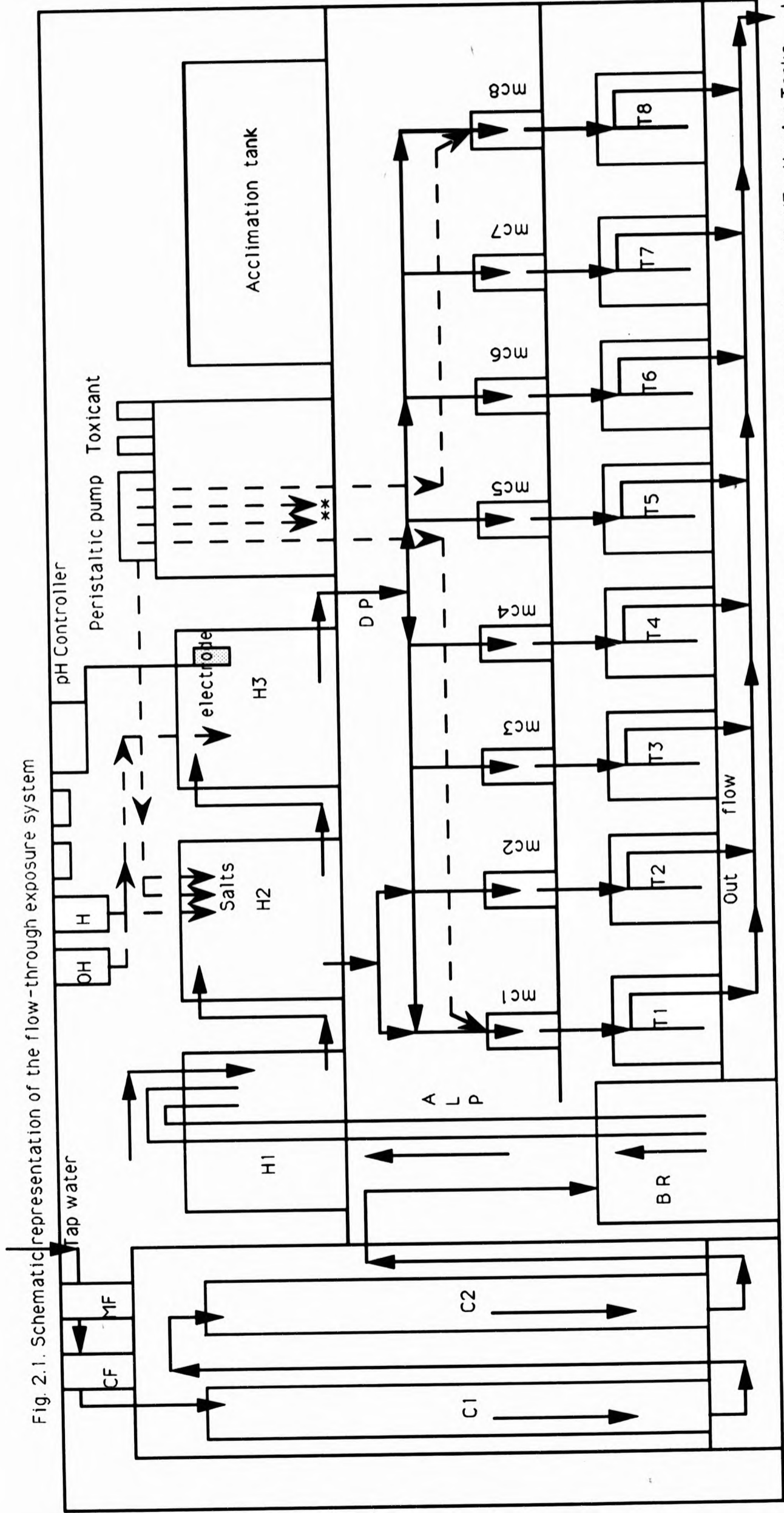

Fig. 2.1. Schematic representation of the flow-through exposure system

Tap water
 MF = Membrane filter
 CF = Carbon filter
 C1-C2 = Resin column
 BR = Bottom reservoir
 H1-H3 = Header Tanks
 Peristaltic pump
 Toxicant
 Salts
 H2
 electrode
 H3
 pH Controller
 D P
 ALP
 mc1
 mc2
 mc3
 mc4
 mc5
 mc6
 mc7
 mc8
 T1
 T2
 T3
 T4
 T5
 T6
 T7
 T8
 Out flow
 To drain
 M F = Membrane filter
 C F = Carbon filter
 C 1 - C 2 = Resin column
 B R = Bottom reservoir
 H 1 - H 3 = Header Tanks
 A L P = Air lift pump
 D P = Water delivery pipe
 m c - m c 8 = Mixing chambers
 T 1 - T 8 = Exposure tanks
 ** 8 tubings supply 8 individual exposure tanks

accessories and were securely placed in a wooden/iron frame in a vertical position as shown in the Fig. 2.1. Each resin column housed about 22-24 kg of either cation resin (Duolite C225, H⁺ form; BDH Ltd.) or anion resin (Duolite A 113, OH⁻ form; BDH Ltd.).

Each deionizer unit produced water of $0.2 \mu\text{S cm}^{-1}$ conductivity and was capable of supplying 32000-35000 l of deionized water within $4 \mu\text{S cm}^{-1}$ conductivity beyond which a deionizer was considered to be exhausted, and subsequently removed from the system, and replaced with a new column containing regenerated resin. This operation could be performed without interrupting the system's operation. Resin, originally procured in Na⁺ and Cl⁻ form, converted into H⁺ and OH⁻ form before use, using the technique for regenerating the resin described below.

Regeneration of resin

Resin was regenerated by 4% solutions of either H₂SO₄ (for cation resin) or NaOH (for anion resin). Five bed volumes of either solution were passed through the appropriate resin column at the rate of 5 ml/100 ml resin/min. At the later stage of regeneration the resin was left to stand for 2-3 hours in solution. The following schedule was followed for washing the regenerated resin: after regeneration each resin column was washed with about 100 l of deionized water and left overnight. For the next 5-7 days resins were washed once per day with 30-50 l of deionized water, and for the next 5-7 days they were washed with same volume of tap water on alternate days. Resin thus washed produced deionized water within $1 \mu\text{S cm}^{-1}$ with 10-15 min of tap water flow.

An additional advantage of the above schedule was the availability of deionized water for washing the resin. As mentioned earlier, to maintain the constant head in the exposure system some water was allowed to overflow from the bottom reservoir and collected in a 200 l tank. This water was used for resin washing. The above schedules,

both for regeneration and washing the resin, resulted in an improvement in performance over the recommended schedule of BDH Ltd.

2.2.2. Maintenance of Ionic Composition of Experimental Water

Throughout this study two synthetic media, differing in their calcium concentrations, were employed. Medium (A) containing 0.6 mg Ca l^{-1} ($0.015 \text{ mmol l}^{-1}$) was regarded as low calcium water (LCW) while the other medium (B) having 16 mg Ca l^{-1} (0.4 mmol l^{-1}) was designated as high calcium water (HCW). The detailed ionic composition of experimental media is presented in Table 2.1. The former medium had 2 mg total hardness as CaCO_3 , and the ratio of cations were maintained approximately according to HMSO (1969) with the exception of the incorporation of potassium salt (see Reader *et al.*, 1988, for inclusion of potassium). The latter medium (B), had a similar ionic composition, except that calcium-salt was added. Higher calcium levels in this case were obtained by addition of $\text{Ca}(\text{NO}_3)_2 \cdot 4\text{H}_2\text{O}$.

Nominal ionic composition of the experimental waters was achieved by automatic dosing of various salt solutions into the second header tank. These were dosed from 3 or 4 stock solutions using a peristaltic pump. Details of the stock solutions are given in Appendix-2

2.2.3. Maintenance of pH and Temperature

The pH of experimental water was aimed at to maintain at 5.2. Water was acidified in the third header tank and was automatically maintained by a automatic pH controller (EIL 943, Kent Industrial). Two single peristaltic pumps (pp) under the control of the pH controller dosed either 0.15M HNO_3 , or 0.1M NaOH . Dosing of acid-base was so adjusted that addition of excess NaOH could be avoided.

Table 2.1. Ionic Composition of Exposure Media

Parameters	Medium A		Medium B	
	mmol l ⁻¹	mg l ⁻¹	mmol l ⁻¹	mg l ⁻¹
Ca ²⁺	0.015	0.600	0.400	16.000
Mg ²⁺	0.038	0.150	0.038	0.150
Na ⁺	0.049	1.100	0.040	1.100
K ⁺	0.005	0.200	0.005	0.200
Cl ⁻	0.004	1.400	0.004	1.400
No ₃ ⁻	0.001	0.070	0.760	47.350
SO ₄ ⁻	0.113	1.240	0.113	1.240
HCO ₃ ⁻	0.036	2.180	0.036	2.180

Water pH in the header tank was set below the desired pH to counteract the neutralizing influence of the fish (mainly owing to ammonia excretion) on the water as it passed through the fish tanks. At the beginning of each experiment some fluctuations in pH in different tanks were observed which could be corrected by manual addition of acid-base. A hand held pH meter (Bibby SMP-1) was usually used for the purpose.

Exposure water temperature was maintained at $27 \pm 1.5^{\circ}\text{C}$ throughout the experiment using 15-20 thermostatically regulated immersion heaters. The heaters were distributed in the bottom reservoir and in the first and second header tanks. Temperature was checked twice daily with a digital pH-Temperature meter (Bibby, SMP-1) and found within the expected range.

2.2.4. Exposure Tank Unit. Water Distribution System and Flow Rates

The fish exposure tank unit consisted of eight glass aquaria (60cm x 30cm x 26cm) of approximately 45 l capacity each and was covered by black polythene lids. A swinging arm outlet maintained the water level in the tanks.

Water from the last header tank was taken by a main PVC delivery pipe (DP) running above the exposure tanks. From this pipe individual connection (made from PVC pipes, T-pieces, polythene hose and narrow end of plastic pipettes) led to individual tank and gravity fed. Plastic clamps were used to regulate water flow. Before entry to the tank, water passed through a coiled tube placed in a mixing chamber into which toxicant was also delivered. From the exposure tanks water went to waste through the tank outlet. Waste water was channelled into an underground drain using a drain pipe.

The flow rate varied from 250-300 ml min⁻¹ in each tank depending on the mass of the fish in each experiment giving a flow rate of 0.9-1.0 l g⁻¹ day⁻¹. Ninety percent replacement time was achieved in 7 to 9 h. Flow rate was monitored every 6-12 h and

adjusted, if necessary.

2.2.5. Toxicant Dosing

Toxicant was dosed into individual exposure tanks using a 16 channel Watson-Marlow Peristaltic pump (Model No.2002/AU). PVC/ silicon tubings of known diameter were used. The free end of each tube was connected to flexible plastic tube which was, in turn, connected to the exposure tank. Toxicant was delivered into a mixing chamber, where it was percolated with experimental water before entering the tanks.

Aluminium as $\text{Al}(\text{NO})_3 \cdot 9\text{H}_2\text{O}$ was used in this study. Concentrations used are described under each individual experimental chapter. Individual stock solutions were prepared for each concentration tested and pH adjusted as desired by adding NaOH.

2.3. Pre-exposure Acclimation of Fish

Fish were acclimated for 10-12 days in static synthetic water medium of the same ionic composition as the control exposure tank at neutral pH. Fish were held in 100 l capacity glass tanks (5 such tanks were available). Loading density was approximately 0.01 kg l^{-1} . Water was changed daily and filtered continuously through an Eihem Filter Pump. Fish were not fed for the last four days of acclimation.

2.4. System Preparation and Pre-exposure Experimentation Protocol:

Before each experiment the system was washed and cleaned with deionized water. Then the flow-through system was run for 12 h continuously before fish were introduced into the exposure tanks. Physical and chemical water parameters were monitored during this time to ensure that the system was operating efficiently. Acceptable limits of stability were usually achieved within 12 h and maintained within limits thereafter.

Fish were then introduced into the exposure tanks and further acclimated for a period of 24-30 h in running water at circumneutral pH. Thereafter the pH was gradually

reduced by addition of dilute HNO₃ and adjusted to 5.2 over a period of 4 h. Dosing of aluminium was then started, with aluminium levels being adjusted in each treatment tank over a period of 2 h by manual addition (only in case of short-term experiment). The experimental protocol and sampling procedures are described in the respective experimental chapters.

2.5. Monitoring Water Quality

pH: pH was monitored at every 12 h during short-term experiments while that for long-term experiments were monitored daily and was measured with a digital meter with built in temperature compensation (PW 9409; Phillips) and a standard glass electrode (CWL Russel pH Ltd).

Total Ammonia, Nitrite and Nitrate: Total ammonia-nitrogen (NH₃-N), nitrite-nitrogen (NO₂-N) and nitrate-nitrogen (NO₃-N) concentrations in water samples from fish holding tanks were analyzed on a Technicon-sampler 1V autoanalyzer.

Total Calcium, Magnesium, Sodium and Potassium: Samples was collected and stored in acid-washed polythene bottles, in a matrix of 1% (v/v) HNO₃ at 4°C. Total levels of each were determined using atomic absorption flame spectroscopy as described in Golterman *et al.* (1978).

Aluminium: Total concentrations of aluminium were measured only in experimental water samples. Samples was taken in duplicate in acid-washed polythene bottles and stored in acid-washed bottles in a matrix of 1% (v/v) HNO₃ at 40C. Sampling schedules are described in individual chapters. Total aluminium concentration of all stored samples was measured by graphite furnace atomic absorption spectroscopy using the programme as described by Exley (1989).

2.6. Determination of Aluminium Content in Gill Tissue

For studies of aluminium accumulation in gills, the second/or third left-hand gill arches of fish were removed. These were then cut into pieces and dried at 60-65°C to a constant weight. Approximately 120-150 mg dried tissue was weighed and digested in 10 ml conc. nitric acid, first at room temperature overnight and then at 95°C for 6-8 h. The tissue digests were subsequently made up to 25 ml with distilled water and stored at 4°C until analysis for aluminium could be carried out. After appropriate dilutions, total aluminium concentrations in the tissue digests were determined as above.

CHAPTER 3
EFFECTS OF SHORT-TERM ACID/ALUMINIUM EXPOSURE ON SOME OF
THE BLOOD AND TISSUE PARAMETERS OF TILAPIA, *OREOCHROMIS*
***NILOTICUS*.**

3.1. INTRODUCTION

Failure in ionoregulation and respiration has been identified as the main toxic syndrome in acid/aluminium-exposed fish (reviews: Wood & McDonald, 1987; Wood, 1989; McDonald *et al.*, 1989; see also Booth *et al.*, 1988; Wood *et al.*, 1988c). Any imbalance in ionic status and respiration in fish may be expected to be reflected in blood parameters because of the close association between the circulatory system, the body of the animal and its environment. Moreover, the responses in blood parameters to environmental changes are rapid, easily measurable and provide an integrated measure of the physiological status of the fish (McKim *et al.*, 1970; Tort and Torres, 1988). The relationship of various blood parameters to energetics, respiration and defence mechanism provides an opportunity to assess and predict stress effects. In fact, blood parameters have long been used as diagnostic tools in recognizing and dealing with environmental stressors.

In freshwater fish, the physiological regulation of the major electrolytes is very sensitive to environmental stressors and plasma electrolytes have been proven to be reliable indicators of acid and acid/aluminium stress (see McDonald *et al.*, 1989). In addition to plasma electrolytes, certain other blood parameters, notably, haematocrit, haemoglobin and mean cell haemoglobin concentration are very often measured not only because of their relationship with respiration but also because they provide a good indication of ionic status (see Soivio and Okari, 1976; Milligan and Wood, 1982). Often measured alongside the above parameters is plasma protein concentration. All these parameters are indices of fluid volume disturbance indicating haemoconcentration or haemodilution which mainly arises because of water shift between extracellular and intracellular compartments (Milligan and Wood, 1982; Goss and Wood, 1988). It is well known that the shifts in water volume are again mainly due to changes in electrolyte levels

(thereby setting osmotic imbalance) in extracellular and intracellular compartments. Therefore, the measurements of these parameters may help in interpreting results in addition to their use in assessing fish health under stress conditions.

Plasma osmolality is an overall measure of the levels of plasma electrolytes and other organic osmolytes and is very often measured in ionoregulation studies. Changes in plasma glucose level induced by a variety of stressors are well documented and are considered as reliable indicator of stress (McLeay, 1975; Silberged, 1975; Hattingh, 1976; Wedemeyer and McLeay, 1981). The elevation of plasma glucose levels in fish by corticosteroids and catecholamines enables the measurement of this parameter as a secondary stress response mediated through direct sympathetic (chromaffin tissue) as well as hormonal (interrenal tissue) pathways (Wedemeyer and McLeay, 1981).

It has been mentioned in Chapter 1 that since exchangeable electrolyte pools exist between plasma and tissue, any changes in plasma electrolyte levels may be compensated by tissue electrolytes. It is thus unlikely that evaluation of ionic status of fish under stress conditions can be made only by measuring plasma levels of electrolytes. Therefore, a combination of plasma and muscle tissue analyses could provide a meaningful assessment of electrolyte status of fish during acid/aluminium exposure.

Fish respond to environmental changes in many ways from modification of hormonal action to changes in behaviour. Again, stress-induced changes in physiological and biochemical functions may be reflected in physical appearance or behavioural pattern of fish (Rand, 1985). Changes in behaviour, coloration, mucus secretion, coughing and ventilation rates have been reported by many workers in fish exposed to acid/aluminium (Ogilvie and Stechey, 1983; Neville, 1985; Phillips and Saleh, 1987; Walker *et al.*,

1988)

Direct visual observation of behaviour and physical appearance of fish under stress is relatively easy and inexpensive (Henry and Atchison, 1979) and in some instances may provide a good indication of physiological and biochemical changes that are taking place (Rand, 1985). It was thus decided to make some qualitative observations on behaviour and general appearance during acid/aluminium exposure in the present study in an attempt to correlate these with physiological data.

The protective effects of ambient calcium (or water hardness) is well established in the toxicology literature as reducing the toxicity of a number of aquatic contaminants (Brown, 1968; Alabaster and Lloyd, 1980; Sprague, 1985). However, as reviewed in Chapter 1, the reported effects of external calcium on aluminium toxicity are contradictory. It was also indicated in Chapter 1 that such discrepancies between published works probably resulted from the differences in the calcium concentrations used. Therefore, a number of calcium concentrations covering a wide range should be used in order to demonstrate the protective effects of external calcium on aluminium toxicity.

As reviewed in Chapter 1 (Table-1.1.), a great many studies have been carried out on physiological problems in fish during acid/aluminium exposure. Most studies, however, have employed only one or two aluminium concentrations, perhaps because they were primarily interested in understanding the toxic mode of action of aluminium or perhaps because they were designed to assess the stress effects of aluminium in acidic environments. There is seldom a linear relationship between concentration and response under stress conditions and so extrapolation of results from a single concentration effect is not possible (Waldichuk, 1979). In general, concentration-response relationships

follow a characteristic pattern, within certain limits, the greater the concentration of the test chemical, the more severe the response. At all concentrations below some minimum (threshold) value there is no measurable adverse response, while at concentrations above some particular value, further changes in the magnitude of response become disproportionately small. The curve drawn to represent the relationship usually takes a sigmoid shape (Rand and Petrocelli, 1985). Hence, it is suggested that in measuring the toxicity of a chemical the objective should be to estimate as precisely as possible the range of chemical concentrations that produce some selected, readily observable and quantifiable response in fish under controlled laboratory conditions (Rand and Petrocelli, 1985).

With many pollutants there may be real threshold response concentrations (Waldichuk, 1979) and their identification might be possible if concentration-dependent responses are obtained. Furthermore, characterization of the stress response and interpretation of its physiological significance requires the establishment of a concentration-response relationship (Shreck, 1981). Therefore, there is a need to identify concentration-response relationship for major physiological responses of fish in acid/aluminium conditions.

As far as can be discerned from the literature, such investigations have been the subject of very few studies. Dalziel *et al.* (1987) established a concentration-response relationship in sodium flux response of aluminium in brown trout, *S. trutta*, at different pH and calcium concentrations, although no threshold concentration was suggested. Ogilvie and Stechey (1983) convincingly identified a 26 h threshold concentration for cough frequency in acid/aluminium-exposed rainbow trout, *S. gairdneri*, and this no doubt encouraged a similar approach for other physiological responses thought to be affected by acid/aluminium exposure.

It would thus appear that the measurement of certain blood and tissue parameters could be used to assess stress effects induced by acid/aluminium exposure and, in particular, would be relevant to the aims of the present study. A number of aluminium concentrations should be used, thus providing a concentration-response relationship which is necessary for a thorough evaluation of a toxicant. Finally, as emphasized earlier, exposure of fish to acid/aluminium under varied external calcium concentrations would be of particular importance.

In the present study, therefore, tilapia were exposed to a number of aluminium concentrations in acidic environments under a range of calcium concentrations. Responses in plasma and tissue electrolytes (sodium, potassium, calcium and magnesium) and a number of other blood parameters (haematocrit, haemoglobin, plasma osmolality and plasma protein levels) were measured. Behavioural responses were also observed.

Specifically, the objectives were:

- (a) to use a number of physiological criteria to assess the physiological status of fish during acid/aluminium stress and also to evaluate their role in overall toxic syndrome;
- (b) to establish a concentration-response relationship and to identify the response threshold range of aluminium for each of the selected parameters; and,
- (c) to evaluate the role of external calcium in mitigating the toxic effect of aluminium.

3.2. MATERIALS AND METHODS

The source of experimental fish, *O. niloticus*, the procedure for maintenance and pre-exposure acclimation of fish, unless otherwise mentioned, were similar to those described in Chapter 2.

3.2.1. Experimental Protocol

A number of experiments were performed in order to investigate the effects of acid/aluminium exposure on a number of blood and tissue parameters and to evaluate the role of external calcium in mitigating the toxic effects. All the experiments described here are of short-term duration and were conducted at a low pH of 5.2. The experimental designs were largely determined by the limitations of the experimental systems.

Experiment 1: Preliminary investigation of ameliorating effects of ambient calcium concentrations on ionic balance in tilapia during acid/aluminium exposure.

This experiment was designed to assess the influence of ambient calcium concentrations in mitigating the toxic effects of acid/aluminium on plasma electrolyte balance using a number of calcium concentrations. From this experiment it was also hoped to choose two calcium concentrations for the experiments which followed.

The basic plan of this experiment was to acclimatize the fish first in low calcium water and then to expose them to acid/aluminium conditions under various higher calcium concentrations. Fish (mean weight 68.38 ± 3.51 g) were acclimated in low calcium (0.4 mg l^{-1} ; 0.01 mmol l^{-1}) synthetic water medium for a period of 9 d under static conditions. On day 10 of acclimation in static conditions, the fish were randomly divided into seven groups. Six of these groups were transferred into flow-through

exposure system and maintained separately for further 1 d under flow-through acclimation conditions in synthetic media differing in calcium concentrations. The nominal calcium concentrations in the exposure media were 0.4, 2.0, 4.0, 8.0, 16.0 and 32.0 mg l⁻¹ (0.01, 0.05, 0.10, 0.20 0.40 and 0.80 mmol l⁻¹, respectively), achieved by dosing with appropriate amounts of Ca(NO₃)₂ · 4H₂O solution. An aluminium concentration of 340 µg l⁻¹ at pH 5.2 was used in this experiment. The toxicant and calcium salt solutions were directly dosed into individual tanks.

The remaining group of fish was maintained under static acclimation conditions at calcium concentrations of 0.4 mg l⁻¹ (0.01 mmol l⁻¹) until the end of the experiment. Simultaneously, a further group of fish was also acclimatized at calcium concentration of 32 mg l⁻¹ (0.8 mmol l⁻¹) under static conditions to ascertain whether acclimation at different calcium concentrations produced any effects on the parameters under investigation.

The fish were sacrificed at the termination of the experiment after 4 d of exposure. Blood samples were collected for analysis of plasma concentrations of sodium, potassium and magnesium. Plasma glucose level and plasma osmolality were also measured.

Experiment 2: Investigation into the interactive effects of calcium and aluminium on the ionic status and some haematological parameters in tilapia during acid/aluminium exposure

In the previous experiment, single and high aluminium concentration was used. Therefore, it was not possible to investigate the possible interactions of external calcium in modifying the toxic effects of acid/aluminium exposure. Therefore, the present experiment was designed so that fish were simultaneously exposed to different

aluminium and calcium concentrations to delineate the possible interactive effects of calcium and aluminium on a number of physiological parameters.

Based on the observations made in Experiment 1, it was decided to use two levels of calcium, i.e. 0.6 mg l⁻¹ (0.015 mmol l⁻¹; LCW) and 16 mg l⁻¹ (0.4 mmol l⁻¹), in the present experiment. Similarly, three concentrations of aluminium, i.e. 0, 150, and 300 µg l⁻¹, were employed. The detailed composition of LCW and HCW, and the procedure for pre-exposure acclimation in respective calcium concentrations are given in Chapter 2. Subsequent acidification and toxicant dosing schedules were the same as described earlier (Chapter 2). Eight fish were tested at each of the six combinations of calcium and aluminium treatments at pH 5.2.

Fish were sampled after 4 d of exposure. Blood samples were collected for analysis of haematocrit and haemoglobin and in order to determine plasma concentrations of total protein, glucose, sodium, calcium, magnesium and potassium. Plasma osmolality was also measured. Gill tissue was analyzed for aluminium concentrations. Water samples were first collected 12 h after the start of the experimental trial and then every 24 h until the termination of the experiment in order to determine total aluminium, sodium and calcium concentrations in the exposure media.

Experiment Series 3: Further investigations into the effects of different aluminium concentrations under low and high calcium conditions

As indicated in the Introduction to this Chapter, the response may vary depending on the aluminium concentrations in the exposure media. Therefore, in the present series of experiments, efforts were made to investigate the concentration-dependent responses in the ionic status of fish using a series of aluminium concentrations under LCW (0.6 mg Ca l⁻¹) and HCW (16 mg Ca l⁻¹) conditions.

Four experimental trials, each of 4 d duration, were carried out during the present experimental series: two replicates in LCW and two replicates in HCW. The composition of the above two media are detailed in Chapter 2 (Table-1.1). During each LCW trial, fish were tested at aluminium concentrations of 0, 20, 70, 120, 170, 220 and 320 $\mu\text{g l}^{-1}$ (0.75, 2.6, 4.50, 6.30, 8.20, 11.90 mmol l^{-1}) in media pH 5.2. Similar aluminium concentrations were also used during experiments with HCW except that fish were not tested at 20 $\mu\text{g Al l}^{-1}$. Instead, a higher aluminium concentration of 520 $\mu\text{g l}^{-1}$ (19.30 mmol l^{-1}) was used. Preliminary trials indicated that exposure to the highest aluminium concentrations in both LCW and HCW conditions would probably severely stress the fish without proving lethal during the present experimental period. Further, groups of fish were also maintained at circumneutral pH (pH 6.8) with no added aluminium allowing assessment of the effects of acid alone exposure.

The average weights of fish used in LCW and HCW experiments were 75.68 ± 3.07 and 67.24 ± 4.71 g, respectively. Eight randomly selected fish (previously acclimatized either in LCW or HCW conditions; see Chapter 2) were distributed in each of the experimental tanks. The number of tanks corresponded to the number of aluminium concentrations used in each experiment. No replicate tanks were used; rather, as mentioned above, the experiments were replicated. As described earlier (Chapter 2), the fish underwent a further period of acclimation in the exposure tanks at circumneutral pH. Subsequent acidification and toxicant dosing schedules were essentially the same as described in Chapter 2.

During the course of the previous experiment it was realized that the physiological responses in fish might vary according to exposure duration. Therefore, in the present series of experiments fish were sampled at day 1 and 4 of exposure in order to determine whether such an effect of exposure duration could be demonstrated. At each

14 277

sampling time four fish were removed from each of the experimental tanks. Blood and muscle tissue were collected from each fish for analysis of plasma and tissue electrolyte concentrations. The results of the previous two experiments indicated that the changes in certain parameters, (notably; Hct, plasma osmolality and plasma concentrations of glucose, sodium and potassium) were strongly influenced by aluminium. Therefore, in the present study it was hoped that the concentration-dependent responses could be demonstrated in the above physiological parameters. Muscle tissue samples were also taken for the analysis of sodium and potassium. Samples of gill tissue were taken in order to determine aluminium accumulation in gills. Behavioural responses were also recorded during the present series of experiments.

3.2.2. Collection of Blood

Each fish was netted individually and immediately anesthezied in benzocaine solution (150 mg l⁻¹, Aldrich Chemical Co.). Immobilization was usually achieved within 1 min. Immediately following immobilization, blood samples were collected by blind caudal puncture (probably mixed blood) with a heparinized (500 i.u. heparin; NH₄-salt) 1 ml disposable syringe equipped with a 25 gauge needle. Blood was then transferred into ice-cold polypropylene centrifuge tubes (1.5 ml) and stored on ice for up to 30 min, during which time samples were processed. Occasionally very little or no haemolysis was observed.

Blood samples were processed in batches after sampling 10-12 fish. Haemoglobin (Hb) and Haematocrit (Hct) were determined immediately after completion of blood sampling from a group of fish. The remaining blood was then spun at 13000 rpm for 4 min using a Micro-Centrifuge (MSE Ltd). The plasma from each sample was then divided into 3 sample aliquots and kept frozen at -70°C for further analysis of glucose, total protein and osmolality, and plasma concentrations of sodium, potassium, calcium and

magnesium.

3.2.3. Collection of Muscle Tissue and Preparation of Tissue Digests for Electrolyte Analysis

A sample of epaxial muscle tissue (usually 0.5g) was removed from the area just anterior to the insertion of the dorsal fin, scraped clean of skin and weighed to the nearest milligram. The tissue samples were then dried overnight. Concentrated nitric acid (approximately 7.5 ml/sample) was added to each sample and heated at 55°C overnight (usually 8-12 h) and then at 100°C until the digestant became clear (usually 6-8 h). Subsequently, 2 ml hydrogen peroxide was added to each acid digested sample for the digestion of fat residues. Filtration of samples were not necessary. Finally, the sample volume was made up to a constant volume of 25 ml with double-distilled water and stored in polypropylene bottles until analysis of various ions could be carried out.

3.2.4. Collection and Preparation of Gill Tissue Digests for Aluminium Analysis.

For studies of aluminium accumulation in gills, the second and/or third left-hand gill arches from the terminal sample of fish were removed. The gill arches were then cut into pieces and dried at 60-65°C to constant weight. Approximately 120-140 mg dried tissue was weighed and digested in 10 ml concentrated nitric acid, first at room temperature and then at 85°C for 4-6 h. The tissue digests were subsequently made up to 25 ml with distilled water and stored at 4°C until analysis for aluminium could be carried out.

3.2.5. Visual Observation of Fish and Physical Appearance

Qualitative visual observations were made on some behavioural aspects and on the physical appearance of fish during Experiment Series 3. Observations included activity of fish, respiratory behaviour such as surfacing and air gulping, integumentary reaction

such as body coloration, mucus secretion and reaction to gentle prodding. Observations were made 2 h after the initiation of the experiments and thereafter at irregular intervals throughout the experimental period. Arrangements were made so that observations could be made with minimal disturbances to fish.

3.2.6. Analytical Procedures

Haematocrit (Hct): Haematocrit (% whole blood) measurements were made on whole blood immediately after blood sampling. Blood was collected in heparinized microhaematocrit tubes (Sigma) by capillary action. The tubes each containing 100-120 μ l whole blood, were sealed at one end with critoseal which proved to be not only rapid but also removed the risk of bunsen flame haemolysing the blood. The tubes were then spun on a 'Hawksley Microhaematocrit Centrifuge' for 5 min at 12000 x g and the values measured against a microhaematocrit reader (Hawksley).

Haemoglobin (Hb): Blood total haemoglobin (Hb) concentration was determined colorimetrically using a 'Sigma Haemoglobin Kit' (Sigma procedure No. 525). The sigma technique is based on the principle that in the presence of alkali potassium ferricyanide, haemoglobin and its derivatives are oxidized to cyanomethaemoglobin. The colour intensity of the latter product at 540 nm is proportional to total haemoglobin concentration.

Aliquots of 20 μ l whole blood were added to 5 ml Drabkin's solution and left for 15 min for colour development. Absorbance was read at 540 nm wavelength on a dual beam Kontron Spectrophotometer (Model No. UVIKON 810) using 1 cm³ disposable cuvette. The absorbance was then converted to haemoglobin concentration (g/100 ml blood) by reference to a standard curve produced from dilution of cyanomethaemoglobin standard solution.

Mean Cell Haemoglobin Concentration (MCHC): MCHC is the ratio of Hb to Hct and is not dependent on blood volume or on the number of red blood cells per unit volume. MCHC (g Hb/ml RBC) was estimated using the expression:

$$\text{MCHC} = \text{Hb concentration/Hct}$$

Plasma Total Protein (TPP): Total plasma protein concentration was determined by using a 'Sigma Diagnostic Kit' (Sigma Procedure No. 540). Sigma employs the modified Biuret method (Gornal *et al.*, 1974). This method was preferred because it is simple, yields less blank absorbance and permits faster colour development.

Aliquots of 100 μ l thawed plasma samples and a standard were each mixed with 5 ml biuret reagent and left for at least 15 min at room temperature. Absorbance readings for standard and test samples versus a reagent blank as reference were read at 540 nm in the above spectrophotometer. The total plasma protein concentration was calculated relative to standard and expressed as g/100 ml plasma.

Plasma Glucose: Plasma glucose level was determined colorimetrically using a Sigma Kit (Sigma Procedure No. 635). The Sigma analytical technique is based on the work of Hyvarian and Nikila (1962) and Feterius (1965) and uses a combination of ortho-toluidine and thiurea. In the presence of heat and acid, ortho-toluidine reacts readily with glucose to form a colour complex. The intensity of colour is proportional to glucose concentration.

Aliquots of 100 μ l plasma and a known standard were each mixed with 5 ml ortho-toluidine in glacial acetic acid. The mixture was then heated in boiling water for exactly 10 min and cooled to room temperature under tap water. Absorbance was measured at 635 nm in the above spectrophotometer. Concentration of glucose of the

sample was calculated relative to standard and is reported as mmol l^{-1} plasma.

Plasma osmolality: Plasma osmolality was measured by a 'Camlab Automatic Micro-osmometer' which operates on the freezing point depression principle. Pure water freezes at 0°C whereas an aqueous solution with an osmolality of 1 osmol/kg water freezes at -1.858°C . Therefore, the freezing point temperature of any aqueous sample, including plasma, can be used to calculate the osmolality of the sample. As osmolality is directly related to freezing point reduction, the digital display is designed to indicate mosmol/kg water rather than temperature.

Measurements were made on 25 μl sample aliquots of thawed plasma. Before measuring any sample, the osmometer was calibrated to zero with distilled water and again to 300 mosmol with a standard solution (Camlab).

Measurement of Electrolytes in muscle Extracts and Plasma: After appropriate dilution, plasma or muscle extracts were analyzed for sodium, potassium, calcium and magnesium concentrations. For the determination of sodium and potassium, the diluent was distilled water. For calcium, 0.2% lanthanum chloride was used as diluent. The other aspects of analysis were the same as described previously in Chapter 2. Concentrations of electrolytes are reported as mmol l^{-1} plasma.

Aluminium Determination: Aluminium concentrations in the gill tissue digests and in the exposure media were determined as detailed earlier (Chapter 2) after appropriate dilution of the samples. Results are expressed as $\mu\text{g Al g}^{-1}$ dry tissue and as $\mu\text{g Al l}^{-1}$ water, respectively.

3.2.7. Statistical Analysis and Data Reporting:

Data have been reported as arithmetic means \pm standard error (S.E.). Before performing any statistical analysis, the normality of data and homogeneity of variances were checked by the 'Probability Plot Co-efficient-test' (Minitab Package) and Bartlett's-test (Statgraphics Package), respectively. If necessary, appropriate transformations (square root or logarithm or X^4 , $(x+ 325)^2$) were selected to obtain normality of data and homogeneity of variances. One-way analysis of variances (one-way ANOVA) was applied to assess the overall effect of calcium (Experiment 1) or aluminium (Experiment Series 3) between calcium or aluminium treatment group means, respectively. When F-values indicated significant difference, LSD-test (least significant difference test) was used to discern specific differences between the groups. When normality and homogeneity of data were not obtained, Kruskal-Wallis non-parametric one-way analysis of variance by rank was used. In that case multiple range test could not be used to detect the specific differences between groups. To detect the interaction between aluminium and calcium, as well as the overall effect of each of the factors, two-way analyses of variances (two-way ANOVA) were used in the case of Experiment 2. The LSD-test was further employed to discern specific differences between groups.

3.3. RESULTS

The results revealed acid/aluminium-induced changes in ion balance and haematology, and also demonstrated the influence of external calcium in the ambient media in reducing such changes. Although there were some deviations between nominal and actual ionic concentrations in the exposure media, for all presentation purposes, nominal concentrations are used.

3.3.1. Experiment 1

3.3.1.1. Water Quality

Table-3.1. presents the data on selected water quality parameters measured during Experiment 1. There was little variation between actual aluminium and calcium concentrations in the exposure tanks and what was intended, although actual sodium concentrations in the media increased considerably. However, differences in sodium concentrations among different exposure tanks were within expected limits.

3.3.1.2. Fish Mortality

Acid/aluminium-exposed fish in lower calcium concentrations appeared severely stressed and one fish died in the fish tank containing 0.4 mg Ca l^{-1} (the lowest calcium concentration) on day 4 of exposure. Although, the exact cause of death was not ascertained, however, it appeared that severe stress in low calcium environment was the likely cause.

3.3.1.3. Blood Parameters

Effects of acclimation

Table-3.2. compares the data on selected plasma parameters in tilapia acclimated at two different calcium concentrations (0.4 and 20 mg Ca l^{-1}). There were no significant

Table-3.1. Measured water quality parameters in the media during a 4 day exposure to acid/aluminium in different external calcium concentrations. Values are arithmetic means \pm S.D. (n=3). Nominal sodium and aluminium concentrations in the media were 1.1 mg l⁻¹ and 340 ug l⁻¹, respectively. Nominal pH was 5.2.

Measured parameters	Nominal calcium concentrations in the exposure tanks (Calcium treatment groups)					
	0.4	2.0	4.0	8.0	16.0	32.0
Aluminium ($\mu\text{g l}^{-1}$)	321.00 \pm 18.00	341.00 \pm 16.00	330.00 \pm 6.00	319.00 \pm 10.00	316.00 \pm 18.00	323.00 \pm 13.00
Calcium (mg l^{-1})	0.53 \pm 0.08	1.70 \pm 0.19	3.69 \pm 0.34	7.01 \pm 0.39	14.42 \pm 1.00	29.60 \pm 1.09
Sodium (mg l^{-1})	1.92 \pm 0.11	1.80 \pm 0.14	1.96 \pm 0.15	1.84 \pm 0.07	1.90 \pm 0.16	1.82 \pm 0.10
pH	5.21 \pm 0.06	5.18 \pm 0.06	5.16 \pm 0.04	5.17 \pm 0.05	5.16 \pm 0.04	5.14 \pm 0.03

Table 3.2. Measured plasma parameters in tilapia acclimated at two different calcium concentrations for 12 days. Values are arithmetic means \pm S.E. (n=6). No significant difference was observed between the groups (t-test; $P>0.05$).

Measured parameters	Acclimation calcium concentrations (mg/l)	
	0.4	32
Sodium (m mol l ⁻¹)	157.16 \pm 1.91	154.89 \pm 2.63
Potassium (m mol l ⁻¹)	2.86 \pm 0.14	2.37 \pm 0.12
Calcium (m mol l ⁻¹)	3.32 \pm 0.33	3.13 \pm 0.16
Magnesium (m mol l ⁻¹)	0.87 \pm 0.06	0.93 \pm 0.04
Glucose (m mol l ⁻¹)	4.14 \pm 0.22	3.71 \pm 0.17
Osmolality (mosmol kg ⁻¹ H ₂ O)	322.00 \pm 3.18	319.17 \pm 1.74

differences in any investigated parameter between the two groups of fish (t-test; $P > 0.05$), although certain parameters were somewhat elevated in fish at the lowest calcium concentration.

Effects of external calcium concentrations on aluminium toxicity

Fig.3.1a shows the effect of calcium concentration on plasma sodium level during acid/aluminium exposure. In general, there was a progressive reduction in the loss of plasma sodium with increasing ambient calcium concentration, being significantly different at calcium concentrations $\geq 8 \text{ mg l}^{-1}$ compared with fish held at the lowest calcium concentration (0.4 mg l^{-1}) (LSD-test). The results of other comparisons are indicated in Fig.3.1a. One-way ANOVA showed that the overall action of calcium in reducing the toxic action of acid/aluminium exposure was highly significant ($P < 0.001$).

Plasma potassium concentrations (Fig.3.1b) were also significantly affected by external calcium during acid/aluminium exposure (One-way ANOVA; $P < 0.001$). In general, fish held at the higher calcium concentrations showed lower plasma potassium concentrations indicating that external calcium reduced the acid/aluminium-induced rise in plasma potassium levels. A posteriori testing (LSD-test) detected a significant effect at calcium concentrations of $\geq 8 \text{ mg l}^{-1}$ compared with fish held at the lowest calcium concentration (0.4 mg l^{-1}).

Figs. 3.1c and 3.2a show the effects on plasma calcium and magnesium concentrations, respectively, in acid/aluminium-exposed fish under different external calcium conditions. No trend or pattern was evident from the results, although magnesium concentration was found to be slightly reduced at the lowest calcium treatment group. One-way ANOVA test failed to show any significant changes in response to variation in the external calcium concentrations on these two plasma ions.

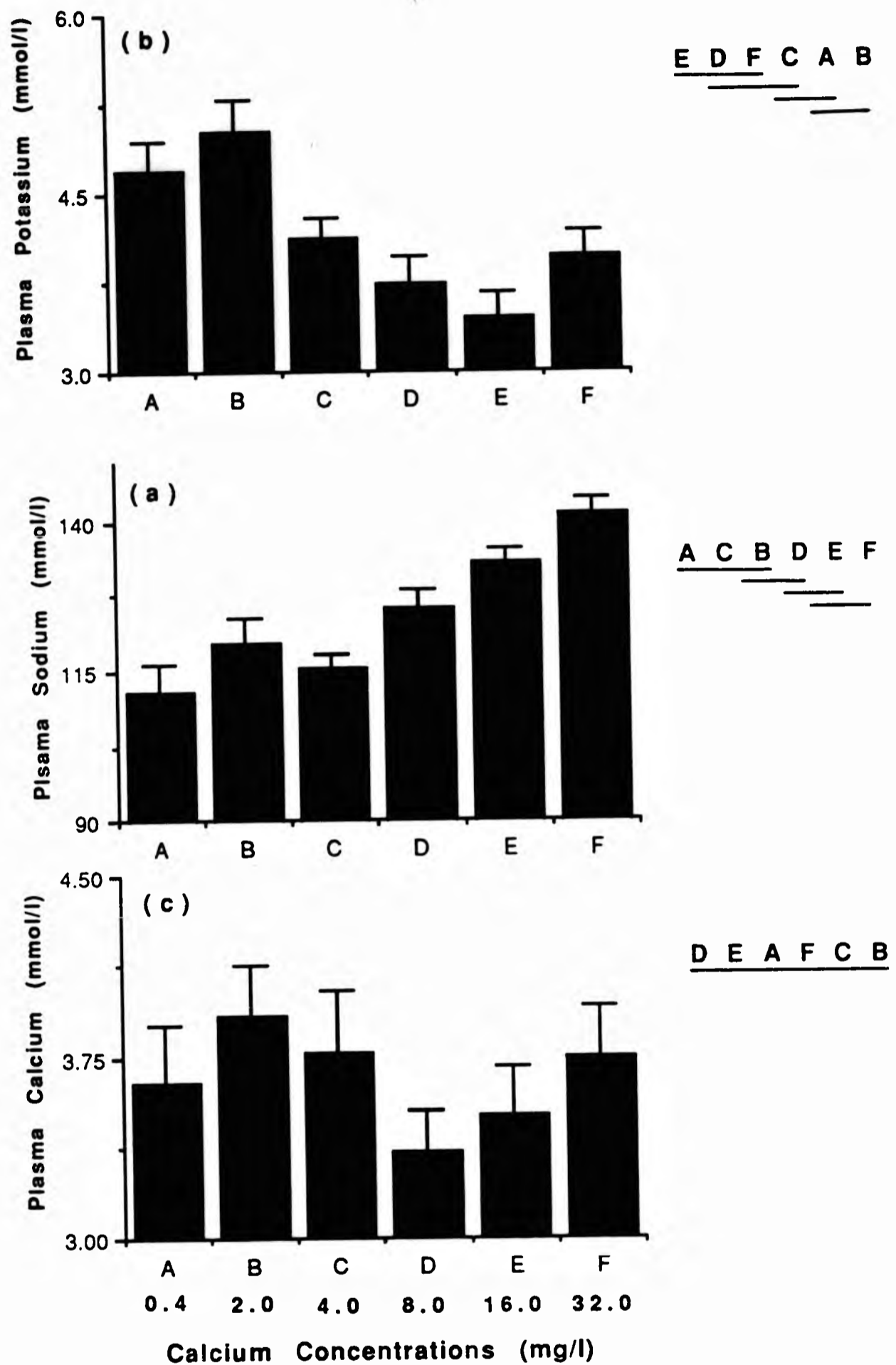

Fig.3.1. Effects of external calcium on plasma concentrations of (a) sodium (b) potassium and (c) calcium in tilapia after 4 d exposure to acid/aluminium conditions. Vertical bars indicate \pm S.E. (n=7-8). Letters underlined by same line are not significantly different (LSD-test; $P < 0.05$).

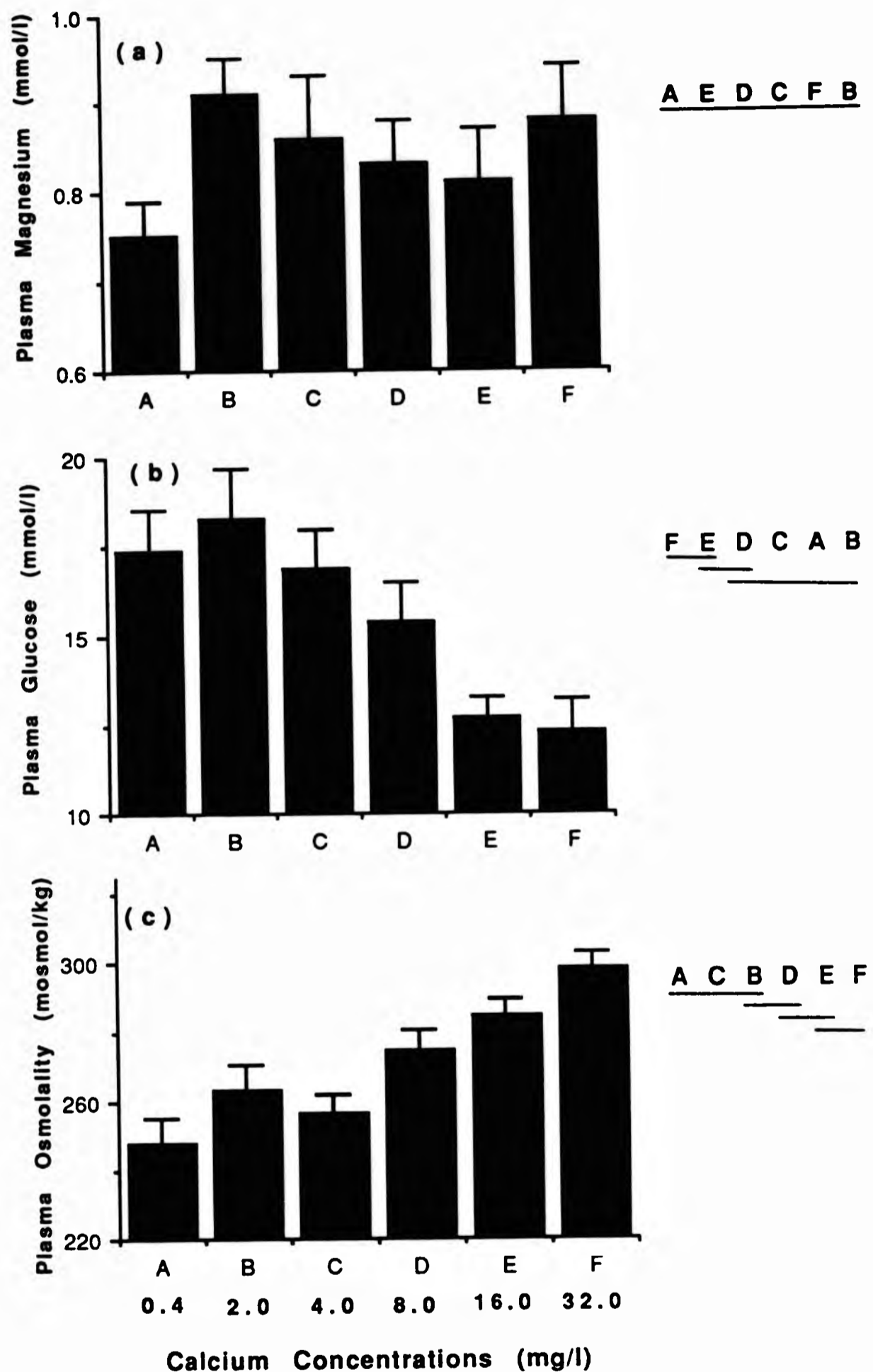

Fig.3.2. Effects of external calcium on plasma concentrations of (a) magnesium and (b) glucose, and (c) plasma osmolality in tilapia after 4 d exposure to acid/aluminium conditions. Vertical bars indicate \pm S.E. (n=8). Letters underlined by same line are not significantly different (LSD-test; P < 0.05).

There occurred a progressive decline in plasma glucose levels with increasing calcium concentrations in the exposure media (Fig.3.2b) suggesting that increased calcium concentrations in the media reduced the acid/aluminium-induced elevation in plasma glucose levels. An one-way ANOVA performed on the data indicated a significant treatment effect of calcium ($P < 0.001$). Compared with the fish at the lowest calcium concentrations, however, a significant effect was observed only at calcium concentrations of $\geq 16 \text{ mg l}^{-1}$ (LSD-test).

Fig.3.2c. illustrates the influence of external calcium concentration on plasma osmolality during acid/aluminium exposure. Fish maintained at the higher calcium concentrations had comparatively higher plasma osmotic values than fish held at the lower calcium concentrations. A LSD-test performed on the data showed that a significant effect was achieved by increasing calcium concentrations to $\geq 8 \text{ mg Ca l}^{-1}$. The overall effect of calcium was significant at $P < 0.001$ (One-way ANOVA).

3.3.2. Experiment 2

3.3.2.1. Water Quality

The results from water quality measurements are documented in Table-3.3. Sodium concentrations in the media increased greatly more than was intended. Near nominal values were achieved in other measured water quality parameters. Similarly, there was little variation in any measured parameter between different experimental tanks.

3.3.2.2 Blood Parameters

Blood haematocrit (Hct) significantly increased at aluminium concentrations of $300 \mu\text{g Al l}^{-1}$ in both LCW and HCW fish and also in fish exposed to $150 \mu\text{g Al l}^{-1}$ under LCW conditions (LSD-test) when compared with fish maintained at $0 \mu\text{g Al l}^{-1}$ in respective calcium water (Fig.3.3a.). The overall effect of aluminium was significant at

Table-3.3. Measured water quality parameters in the media during a short-term (4 d) exposure to acid/aluminium in LCW (0.6 mg l⁻¹) and HCW (16.0 mg l⁻¹) conditions. Values are arithmetic means \pm S.D. (n=3). Nominal pH was 5.2.

Measured parameters	Nominal aluminium concentrations (ug l ⁻¹) in the exposure media (Aluminium treatment tanks)		
	LCW	HCW	HCW
	0	150	300
Aluminium (µg l ⁻¹)	2.00 \pm 1.00	143.00 \pm 8.00	284.00 \pm 14.00
Calcium (mg l ⁻¹)	0.54 \pm 0.04	0.56 \pm 0.07	0.53 \pm 0.06
Sodium (mg l ⁻¹)	1.66 \pm 0.04	1.75 \pm 0.11	1.84 \pm 0.07
pH	5.15 \pm 0.03	5.17 \pm 0.04	5.21 \pm 0.05
	0	150	300
	1.00 \pm 2.00	138.00 \pm 7.00	291.00 \pm 18.00
	15.15 \pm 1.55	14.53 \pm 0.93	14.25 \pm 1.01
	1.68 \pm 0.08	1.70 \pm 0.07	1.87 \pm 0.09
	5.16 \pm 0.04	5.19 \pm 0.05	5.18 \pm 0.05

P <0.001. Fish exposed to elevated levels of aluminium in HCW conditions had lower levels of Hct than the corresponding groups under LCW, although a significant difference was found between fish groups at aluminium concentrations of 150 $\mu\text{g l}^{-1}$. This interaction of calcium in reducing aluminium-induced changes in blood Hct was significant at P <0.05 (two-way ANOVA).

Haemoglobin (Hb) concentrations in blood tended to be higher at the elevated levels of aluminium in the exposure media (Fig.3.3b). Significant differences, however, were found only in fish at the highest aluminium concentrations (300 $\mu\text{g l}^{-1}$) in both calcium waters (LSD-test). The overall effect of aluminium was significant at the level of P <0.01. There was no clear pattern in the effects of calcium concentrations on blood Hb levels in the present study and no significant action of calcium, either independently or by interaction with aluminium, on Hb concentration, was observed as indicated from the results of two-way ANOVA.

Mean Cell haemoglobin Concentration (MCHC) declined significantly in fish at the highest aluminium concentrations (both in LCW and HCW) as well as at aluminium concentration of 150 $\mu\text{g l}^{-1}$ in LCW conditions from respective fish group maintained at 0 $\mu\text{g Al l}^{-1}$ (Fig.3.3c.) (LSD-test). This action of aluminium was highly significant (P <0.001; two-way ANOVA). Again, each group of fish at the elevated levels of aluminium under HCW conditions showed significantly higher MCHC-values than the corresponding groups of fish in LCW conditions. This interaction of calcium was statistically significant (P <0.05; two-way ANOVA).

Total plasma protein concentration was raised by elevated aluminium concentrations in the exposure media (Fig.3.4a). However, significant changes were observed only in fish exposed to aluminium concentrations of 150 $\mu\text{g l}^{-1}$ in LCW and in fish exposed to 300

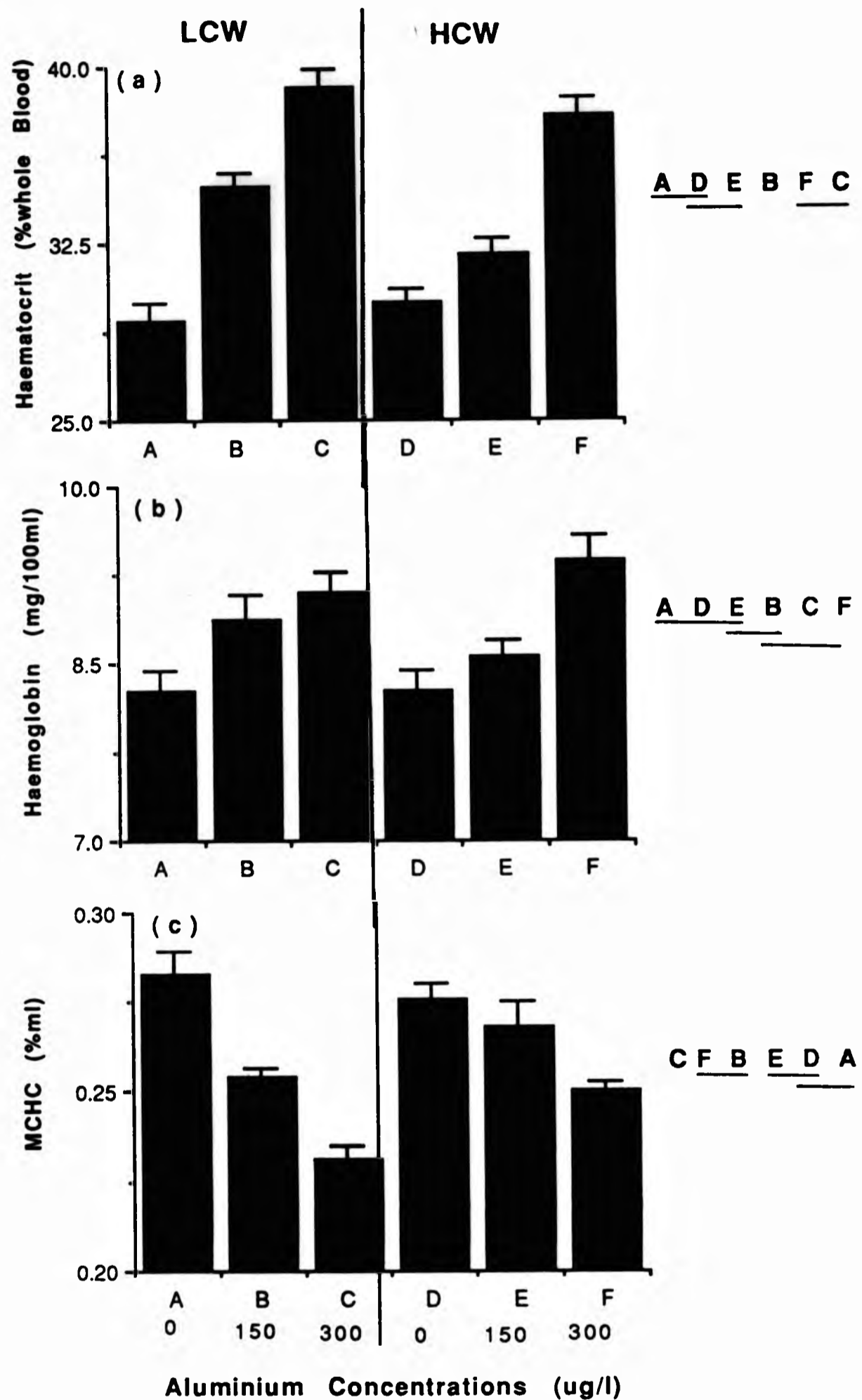

Fig.3.3. Changes in (a) haematocrit (b) haemoglobin and (c) mean cell haemoglobin concentrations in tilapia exposed to acid /aluminium for 4 days under LCW and HCW conditions. Vertical bars indicate \pm S.E. (n=8). Letters underlined by same line are not significantly different (LSD-test; P < 0.05).

$\mu\text{g Al l}^{-1}$ under HCW conditions (LSD-test). The overall effect of aluminium was significant at $P < 0.01$ (two-way ANOVA). Calcium concentrations did not exert any significant influence on total plasma protein concentration independently or in combination with aluminium and no particular trend emerged from the results on the effect of calcium external calcium on aluminium-induced changes in plasma protein.

In both LCW and HCW conditions, elevated aluminium concentrations (300 and 150 $\mu\text{g l}^{-1}$) raised plasma glucose levels two to seven-fold (Fig.3.4b.). The increases in plasma glucose were significant in all treatment groups of fish compared with fish maintained at 0 $\mu\text{g Al l}^{-1}$ in respective calcium conditions (LSD-test). Further, each group of fish under LCW had higher glucose levels than the corresponding groups of fish under HCW conditions. The overall effects of calcium and aluminium were found to be significant ($P < 0.001$; two-way ANOVA) and at the same time, there was a significant interaction in the effects of the two treatment variables ($P = 0.008$), suggesting that calcium concentrations alone in the media had exerted some degree of influence on plasma glucose levels.

Significant decreases in plasma osmolality (Fig.3.4c) were observed in fish exposed at the highest aluminium concentrations in both LCW and HCW and also in fish exposed to 150 $\mu\text{g Al l}^{-1}$ in LCW conditions (LSD-test). This action of aluminium was highly significant (two-way ANOVA). Groups of fish at the elevated levels of aluminium in HCW conditions showed higher osmotic values than the fish of the same exposure conditions in LCW. However, a significant difference was found between fish groups exposed at aluminium concentrations 300 $\mu\text{g l}^{-1}$ (LSD-test). The interactive effects of calcium on aluminium-induced changes in plasma osmolality was significant ($P < 0.001$), as indicated in the results of two-way ANOVA.

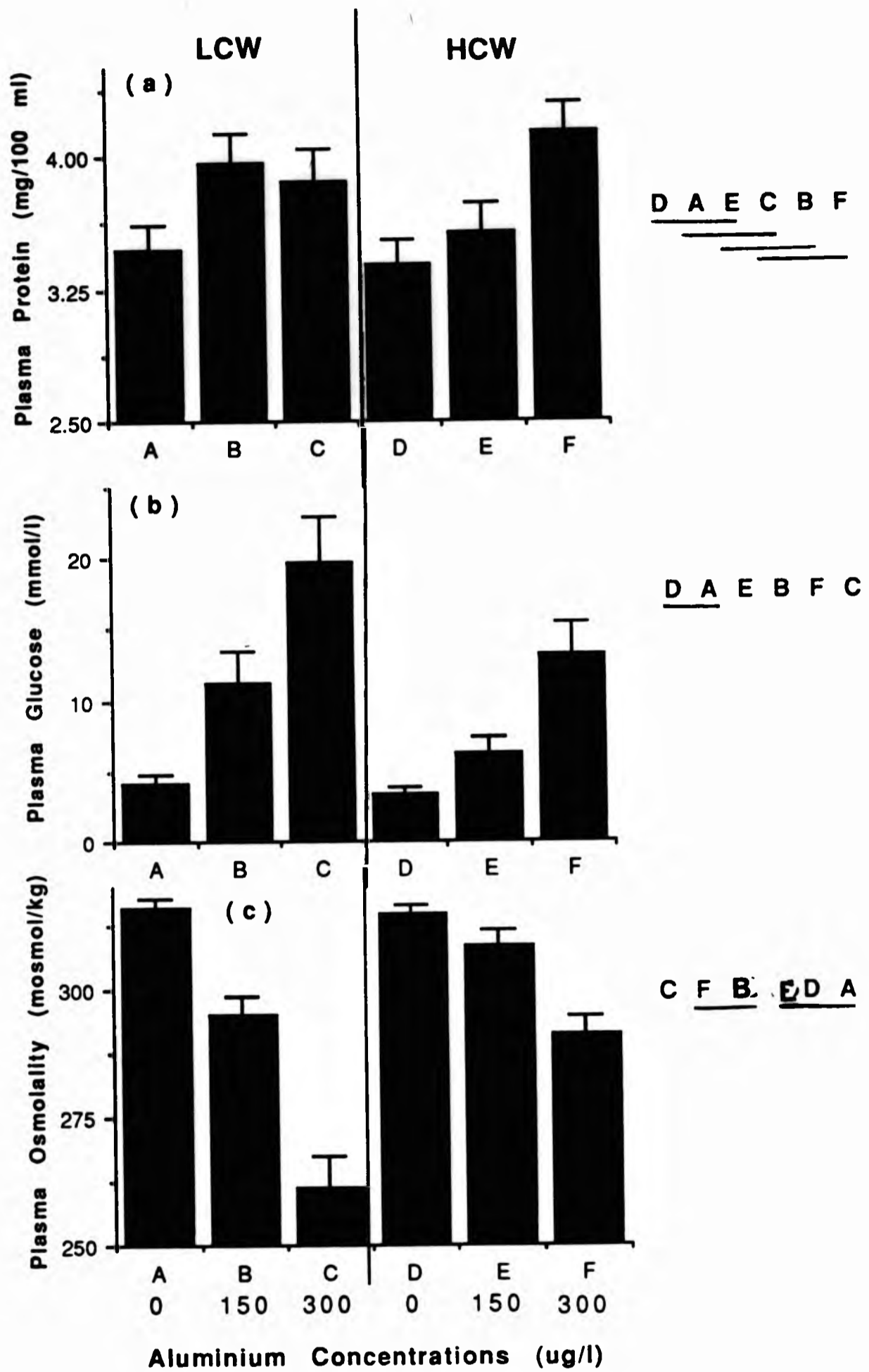

Fig.3.4. Changes in plasma concentrations of (a) total protein and (b) glucose, and (c) plasma osmolality in tilapia exposed to acid/aluminium for 4 days under LCW and HCW conditions. Vertical bars indicate \pm S.E. (n=8). Letters underlined by same line are not significantly different (LSD-test; $P < .05$).

Plasma sodium concentrations (Fig.3.5a) were significantly reduced at the highest aluminium concentration ($300 \mu\text{g l}^{-1}$) in both calcium treatments and also at aluminium concentration of $150 \mu\text{g l}^{-1}$ in LCW conditions only compared with fish held at $0 \mu\text{g Al l}^{-1}$ in respective calcium concentrations (LSD-test). The overall effect of aluminium was significant at $P < 0.001$. Each group of fish at the elevated levels of aluminium had significantly higher levels of plasma sodium under HCW than the corresponding groups of fish in LCW conditions (LSD-test) indicating that higher calcium levels in the exposure media had reduced acid/aluminium-induced loss in plasma sodium. This action of calcium was significant at the level $P < 0.01$ (two-way ANOVA).

There was a tendency for plasma potassium concentration to be increased at the elevated levels of aluminium (Fig.3.5b.). However, this was only significant at the highest aluminium concentrations ($300 \mu\text{g l}^{-1}$) in both calcium waters and also in fish at $150 \mu\text{g Al l}^{-1}$ in LCW compared with fish held at aluminium concentrations of $0 \mu\text{g l}^{-1}$ under respective calcium concentrations (LSD-test). An ANOVA test showed a significant effect of aluminium at the level of $P < 0.001$. There was no clear pattern in the effects of calcium concentrations on plasma potassium concentration, although in one comparison ($150 \mu\text{g Al l}^{-1}$), the fish in LCW showed significantly higher potassium levels in plasma than the corresponding group of fish in HCW conditions (LSD-test). This interaction of aluminium and calcium was found to be significant ($P < 0.05$; two-way ANOVA).

There was a slight tendency for plasma calcium (Fig.3.5c.) to be elevated at the highest aluminium concentrations ($300 \mu\text{g Al l}^{-1}$), although the effect was only significant in LCW conditions (LSD-test). Two-way ANOVA showed a significant effect of aluminium ($P < 0.05$) but indicted no action of calcium either independently or in combination with aluminium on plasma calcium levels.

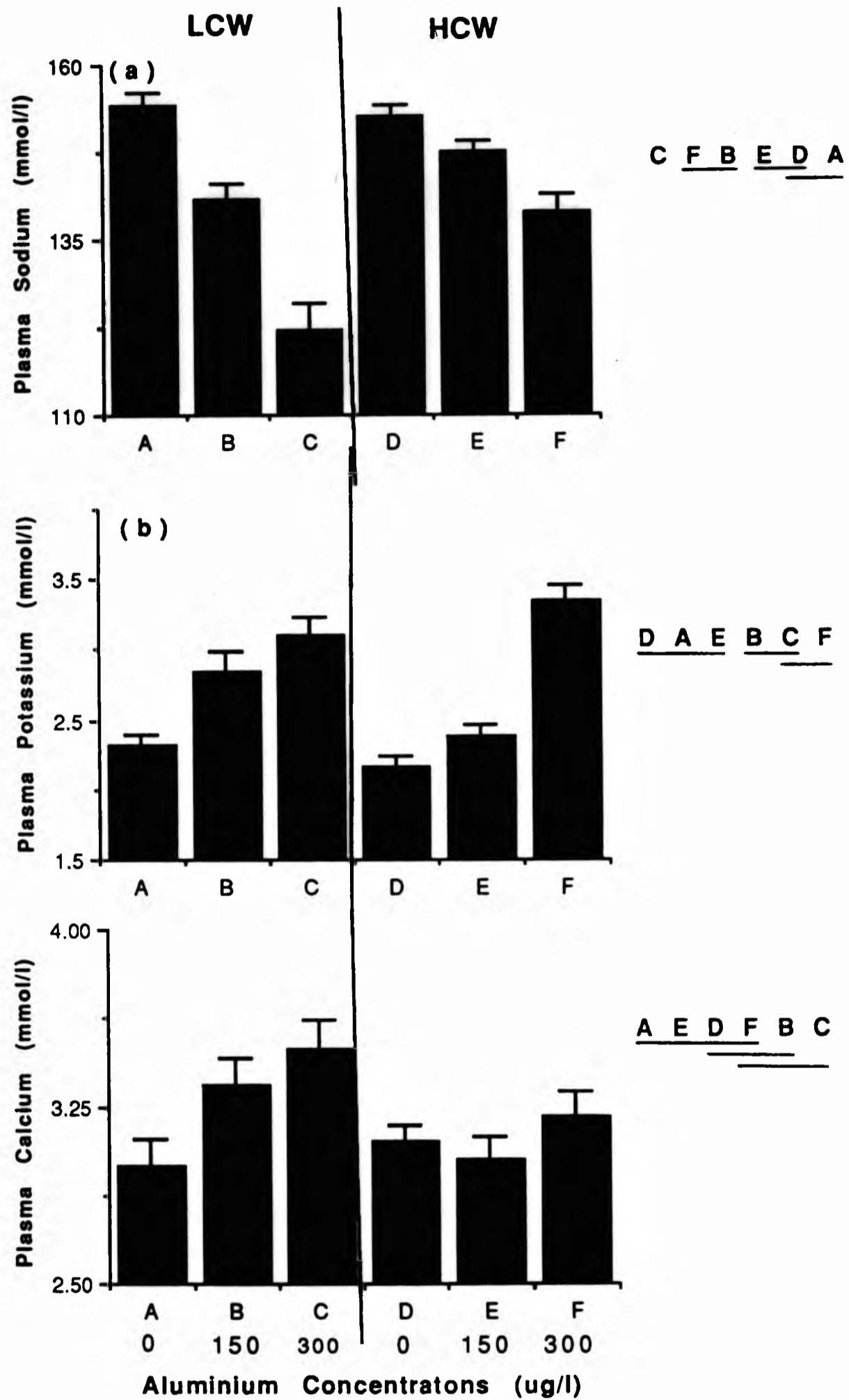

Fig.3.5. Changes in plasma concentrations of (a) sodium (b) potassium and (c) calcium tilapia exposed to acid /aluminium for 4 days under LCW and HCW conditions. Vertical bars indicate \pm S.E. (n=8). Letters underlined by same line are not significantly different (LSD-test; $P < 0.05$).

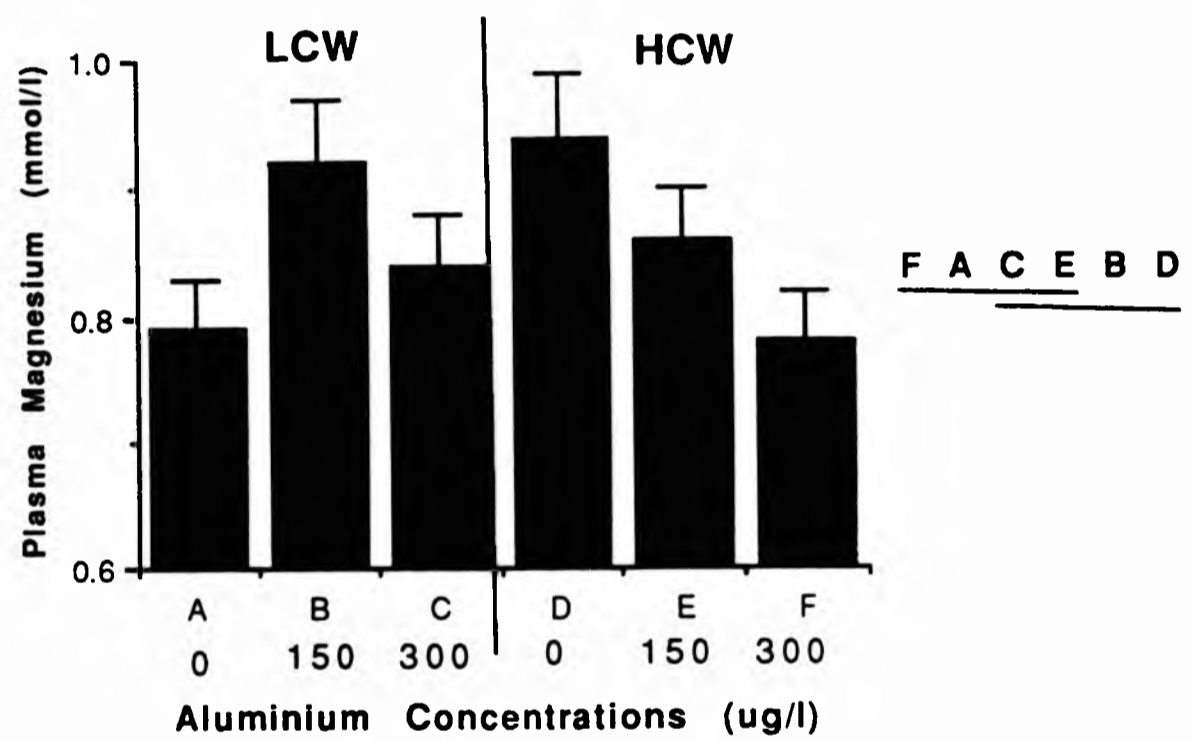

Fig.3.6. Changes in plasma magnesium concentration in tilapia exposed to acid /aluminium for 4 days under LCW and HCW conditions. Vertical bars indicate \pm S.E. (n=8). Letters underlined by same line are not significantly different (LSD-test; $P < 0.05$).

Plasma magnesium concentrations (Fig.3.6.) were significantly reduced at the highest aluminium concentration ($300 \mu\text{g l}^{-1}$) in HCW conditions (LSD-test), although the overall effect of aluminium was found to be insignificant as indicated from the results of two-way ANOVA and no clear pattern is distinguishable in the data on the effect of calcium or aluminium. However, there was a significant interaction of the factors ($P < 0.05$).

3.3.3. Experiment Series 3

It was stated in the 'Materials and Methods' Section of this Chapter that replicate experiments were carried out in each calcium conditions during experiment Series 3 (Experiments 3A1 & 3A2 in LCW, and Experiments 3B1 & 3B2 in HCW conditions). In each calcium treatment (LCW and HCW experiments), the second experiment was conducted immediately after termination of the first experiment and the fish used in replicate experiments came from the same stock. Water quality measurements revealed no noticeable difference between replicates (see below). Thus the results from the replicate experiments have been combined. Since LCW and HCW experiments were conducted at widely different time period and since two different stock fish were used, for reasons of statistical validity, the data from LCW and HCW experiments were not compared statistically. In reporting the results of the present study particular attention was paid to trends in the data and an attempt was made to identify a 4 d response threshold concentration of aluminium (i.e. a concentration below which any concentration does not elicit any significant response when compared with response in control fish) for each parameter.

3.3.3.1. Water Quality

The results from water quality measurements made during LCW and HCW experimental trials are shown in Tables 3.4 and 3.5, respectively. As with previous experiments,

Table-3.4. Measured water quality parameters in different exposure tanks during short-term (4 d) experiments with acid/aluminium at pH in LCW conditions. Values are arithmetic means \pm S.D. (n=3). Nominal calcium and sodium concentrations in the media were 0.6 and 1.10 mg l⁻¹, respectively.

Exposure tanks	Measured water quality parameters							
	Experiment 3A1		Experiment 3A2					
Nominal Aluminium conc ugl ⁻¹	Aluminium $\mu\text{g l}^{-1}$	Calcium mg l ⁻¹	Sodium mg l ⁻¹	pH	Aluminium $\mu\text{g l}^{-1}$	Calcium mg l ⁻¹	Sodium mg l ⁻¹	pH
320	297 \pm 26	0.61 \pm 0.06	1.74 \pm 0.12	5.16 \pm 0.08	307 \pm 12	0.57 \pm 0.06	1.81 \pm 0.11	5.14 \pm 0.09
220	218 \pm 18	0.54 \pm 0.05	1.67 \pm 0.14	5.17 \pm 0.05	201 \pm 8	0.55 \pm 0.07	1.72 \pm 0.09	5.22 \pm 0.06
170	159 \pm 9	0.56 \pm 0.09	1.58 \pm 0.08	5.17 \pm 0.03	165 \pm 13	0.61 \pm 0.06	1.56 \pm 0.08	5.16 \pm 0.03
120	121 \pm 6	0.52 \pm 0.04	1.57 \pm 0.08	5.18 \pm 0.05	106 \pm 10	0.59 \pm 0.08	1.64 \pm 0.14	5.16 \pm 0.06
70	63 \pm 7	0.56 \pm 0.08	1.52 \pm 0.13	5.21 \pm 0.07	66 \pm 13	0.58 \pm 0.05	1.68 \pm 0.07	5.18 \pm 0.07
20	16 \pm 3	0.55 \pm 0.03	1.54 \pm 0.07	5.15 \pm 0.03	16 \pm 5	0.62 \pm 0.05	1.51 \pm 0.08	5.16 \pm 0.04
0	3 \pm 2	0.57 \pm 0.04	1.45 \pm 0.07	5.14 \pm 0.04	2 \pm 2	0.57 \pm 0.04	1.50 \pm 0.10	5.15 \pm 0.06
Control*	3 \pm 1	0.54 \pm 0.05	1.62 \pm 0.16	6.79 \pm 0.14	4 \pm 2	0.59 \pm 0.03	1.73 \pm 0.12	6.84 \pm 0.07

* Circumneutral pH with no added aluminium

Table-3.5. Measured water quality parameters in different exposure tanks during short-term (4 d) experiments with acid/aluminium at pH in HCW conditions. Values are arithmetic means \pm S. D. (n=3). Nominal calcium and sodium concentrations in the media 16.00 and 1.10 mg l⁻¹, respectively.

Exposure tanks	Measured water quality parameters							
	Experiment 3B1		Experiment 3B2					
Nominal aluminium conc.	Aluminium $\mu\text{g l}^{-1}$	Calcium mg l ⁻¹	Sodium mg l ⁻¹	pH	Aluminium $\mu\text{g l}^{-1}$	Calcium mg l ⁻¹	Sodium mg l ⁻¹	pH
520	481 \pm 29	14.36 \pm 1.84	1.90 \pm 0.15	5.23 \pm 0.09	460 \pm 23	14.09 \pm 1.48	1.80 \pm 0.08	5.17 \pm 0.08
320	309 \pm 14	14.92 \pm 1.09	1.78 \pm 0.06	5.18 \pm 0.04	301 \pm 19	15.21 \pm 1.70	1.70 \pm 0.08	5.22 \pm 0.10
220	204 \pm 8	13.94 \pm 1.26	1.62 \pm 0.11	5.14 \pm 0.08	215 \pm 11	14.64 \pm 1.12	1.76 \pm 0.12	5.16 \pm 0.06
170	165 \pm 11	14.66 \pm 1.38	1.55 \pm 0.07	5.16 \pm 0.05	149 \pm 5	14.28 \pm 0.84	1.56 \pm 0.10	5.15 \pm 0.04
120	112 \pm 5	14.84 \pm 0.78	1.60 \pm 0.06	5.16 \pm 0.04	108 \pm 8	14.90 \pm 1.62	1.60 \pm 0.07	5.16 \pm 0.06
70	59 \pm 7	15.00 \pm 1.54	1.55 \pm 0.09	5.14 \pm 0.07	56 \pm 5	15.04 \pm 1.50	1.54 \pm 0.09	5.16 \pm 0.05
0	5 \pm 2	14.78 \pm 1.02	1.57 \pm 0.06	5.16 \pm 0.06	3 \pm 1	14.90 \pm 1.20	1.50 \pm 0.05	5.14 \pm 0.04
Control*	3 \pm 2	14.86 \pm 0.90	1.68 \pm 0.09	6.86 \pm 0.06	4 \pm 2	15.20 \pm 1.30	1.65 \pm 0.08	6.80 \pm 0.05

* Circumneutral pH with no added aluminium

other than sodium, there was little variation between actual and intended water quality. Further, there were no noticeable variations in any measured parameter between replicate experiments.

3.3.3.2. Visual Observations of Fish

Considerable changes in the physical appearance and behavioural activities of fish were observed. The onset, duration and severity of the changes were found to be strongly related to aluminium and calcium levels in the exposure media and to duration of the experiments.

The first observed symptoms of distress following aluminium exposure was heightened activity, particularly in fish at higher aluminium concentrations (> 170 and $> 220 \mu\text{g l}^{-1}$, in LCW and HCW conditions respectively). This change in activity appeared in fish exposed to the highest aluminium level within 15-20 min of acid/aluminium exposure and was also evident at aluminium concentrations of 220 and 170 $\mu\text{g l}^{-1}$ in LCW, and 520 and 320 $\mu\text{g Al l}^{-1}$ in HCW fish, appearing somewhat earlier in LCW fish. The changes in activity were characterized by to and fro swimming and aggressiveness, the latter being more pronounced in fish exposed under LCW conditions. However, the heightened activity abated within a few hours (usually 2-5 h) but was followed by increased surfacing and air gulping. On the second day of exposure all the above groups of fish were found gulping air at the water surface and, in addition, fish exposed to 320 $\mu\text{g Al l}^{-1}$ in LCW conditions crowded near water inlet. Similar behaviour was also observed among fish held at aluminium concentrations of 220 and 520 $\mu\text{g l}^{-1}$, in LCW and HCW, respectively, by the third day of exposure. By this time, fish exposed to 320 $\mu\text{g Al l}^{-1}$ (in LCW) were no longer observed to be crowded near the water inlet but rather had dispersed and remained mostly at the bottom of the tanks. This group of fish did not respond well to gentle prodding and by the fourth day of

exposure appeared exhausted. Some fish were observed to open their mouths wide and to flare their opercula. A similar suite of responses was also shown by fish groups exposed to aluminium concentrations of 220 and 520 $\mu\text{g l}^{-1}$ in LCW and HCW conditions, respectively, although the symptoms were somewhat less pronounced. The remaining groups of fish held in media containing ≥ 170 and ≥ 220 $\mu\text{g Al l}^{-1}$ in LCW and HCW, respectively, were observed gulping air at the water surface. No observable changes in activity pattern or surfacing and air gulping, however, were observed in the remaining groups of fish exposed either to acid or acid/aluminium conditions.

Certain integumentary responses represented another important aspect of acid/aluminium exposure, notably, changes in body coloration and increased mucus secretion. In general, fish exposed to concentrations of ≥ 120 Al l^{-1} in LCW and ≥ 170 $\mu\text{g Al l}^{-1}$ in HCW, progressively lost normal body coloration and body sheen with increasing aluminium concentration and duration of exposure. At the termination of the experiments (after 4 d) fish exposed to 320 $\mu\text{g Al l}^{-1}$ in LCW were found to be very pale, accompanied by the appearance of marked, reddened areas on the body surface, particularly on the lateral line area, caudal region and base of the pectoral fins. Similar changes were also found in fish exposed to aluminium concentrations of 220 and 520 $\mu\text{g l}^{-1}$ in LCW and HCW fish, respectively, although they were comparatively less pronounced. Fish exposed to acid alone or to lower aluminium concentrations (e.g. ≤ 70 and ≤ 120 $\mu\text{g Al l}^{-1}$, in LCW and HCW fish, respectively) did not show any changes in body coloration.

Increased mucus secretion was one of the most noticeable and consistent observations made in this study. Precipitated mucus, sloughed off the fish body, was found in suspension on the bottom of the fish tanks. The severity of mucus secretion increased with increased aluminium concentration, again appearing earlier in LCW fish and in fish

exposed to high aluminium concentrations. Within 5-6 h of exposure precipitated mucus was clearly visible in fish tanks containing $320 \mu\text{g Al l}^{-1}$ and by the second day of exposure the secretion of mucus had increased dramatically. It had noticeably reduced on the fourth day of exposure, indicating exhaustion of mucous reserves. Other groups of fish did not appear to exhaust mucous reserves. No noticeable mucus sloughing was observed in fish exposed to ≤ 70 and $\leq 220 \mu\text{g Al l}^{-1}$ in LCW and HCW conditions, respectively, or in acid-exposed fish, although at the time of last sampling, these groups of fish appeared to be more 'slimy' than usual. By contrast, fish exposed to an aluminium concentration of $320 \mu\text{g l}^{-1}$ were found to be almost completely devoid of surface mucus and had roughened body surface. Similarly, fish exposed to 220 and 520 $\mu\text{g Al l}^{-1}$, in LCW and HCW, respectively, also had distinctly less surface mucus although this was less noticeable than among the former group of fish.

3.3.3.3. Blood Parameters

Haematocrit (Hct)

Figs. 3.7a. & 3.8a. show the changes in blood Hct in tilapia during LCW and HCW experiments, respectively. Haematocrit levels were unaffected by exposure to acid alone both in LCW and HCW conditions. In general, Hct levels increased progressively with increasing aluminium concentrations in the exposure media. However, the increases in Hct were not always proportional to the exposure aluminium concentrations.

After 1 d exposure under LCW conditions (Fig.3.7a.), a maximum increase of 33% over control value was recorded in fish at the highest aluminium concentration. This action of aluminium was significant at the level $P < 0.001$. A posteriori LSD-test showed that, compared with control fish (fish at circumneutral pH without added aluminium), significant differences occurred in fish at aluminium concentrations $\geq 170 \mu\text{g l}^{-1}$. By day 4, Hct levels had increased by approximately 43% over the control fish, being

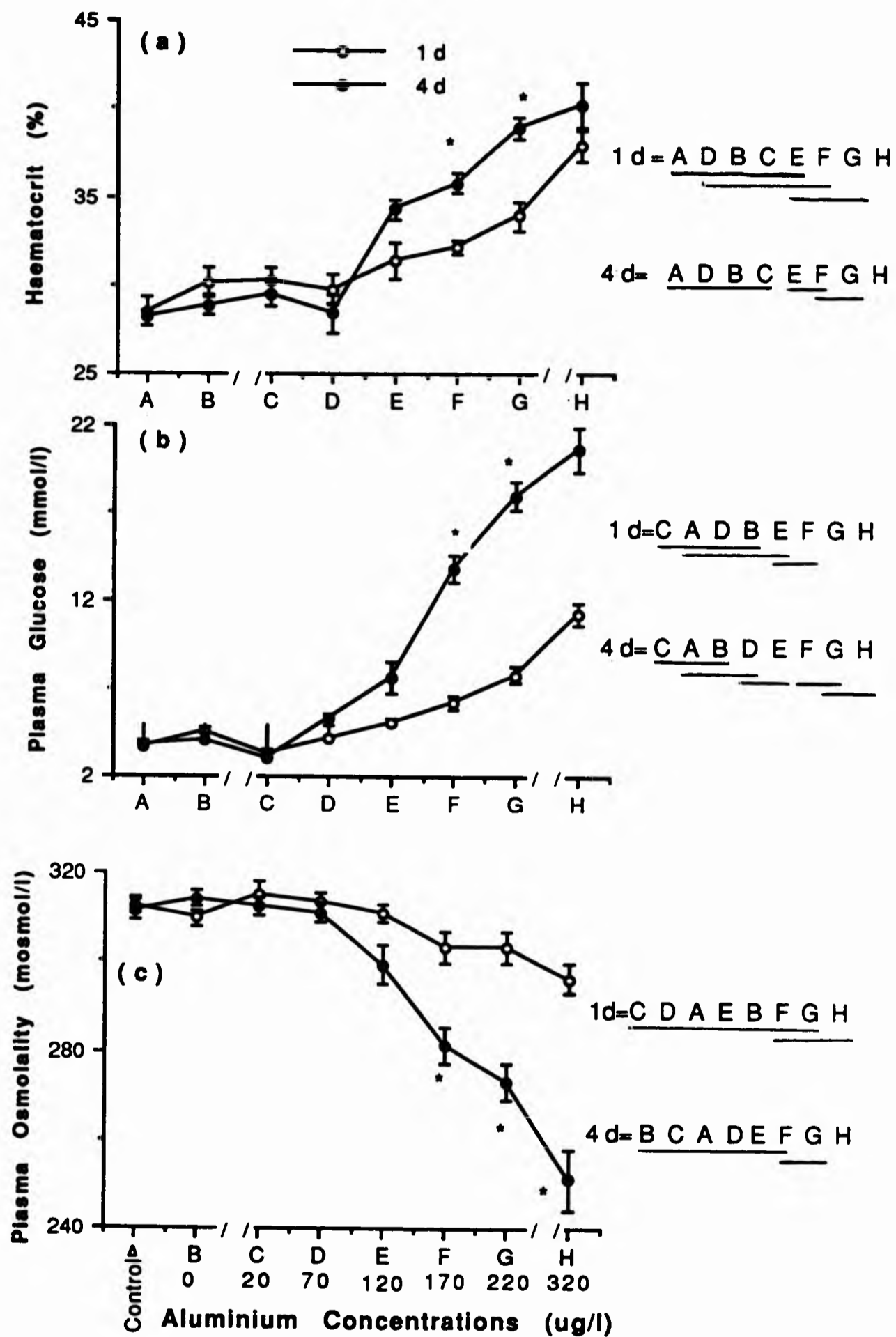

Fig. 3.7. Changes in (a) haematocrit (b) plasma glucose (c) plasma osmolality in tilapia after 4 d exposure to different aluminium concentrations at pH 5.2 in LCW conditions. Vertical bars indicate \pm S.E. (n=8). Letters underline by same line are not significantly different. Asterisks show significant differences from corresponding 4 d samples.

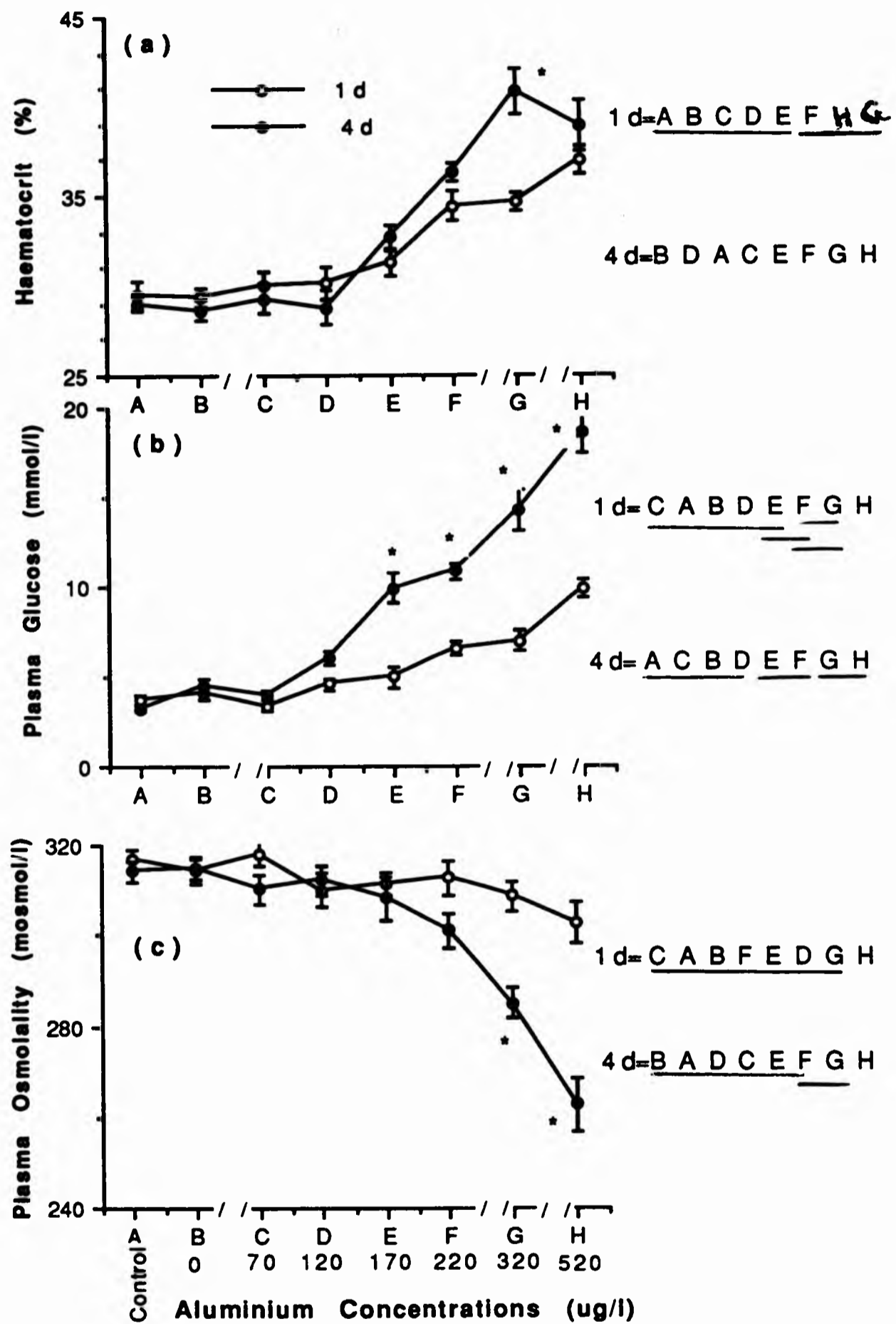

Fig. 3.8. Changes in (a) haematocrit (b) plasma glucose and (c) plasma osmolality in tilapia after 4 d exposure to different aluminium concentrations at pH 5.2 in HCW conditions. Vertical bars indicate \pm S.E.(n=8). Letters under same line are not significantly different. Asterisks show significant differences from corresponding 1 d samples.

significantly different at aluminium concentrations of $\geq 120 \mu\text{g l}^{-1}$ (LSD-test) (Fig.3.7a). The overall aluminium treatment effect was significant at $P < 0.001$; one-way ANOVA). It appears from the results that a 4 d response threshold concentration of aluminium for Hct increase lies between aluminium concentrations 70 and $120 \mu\text{g l}^{-1}$. With regard to Hct increase, after exceeding the response threshold concentrations, the maximum response in Hct increase (approximately $40/\text{mg Al l}^{-1}$) occurred between aluminium concentrations 120 and $220 \mu\text{g l}^{-1}$. However, as aluminium concentration increased from 220 to $320 \mu\text{g l}^{-1}$ the rate of Hct increase dropped to approximately $9/\text{mg Al l}^{-1}$, suggesting that there may be a maximum response limit beyond which further increases in exposure aluminium concentrations probably have little effect.

During experiments with HCW (Fig.3.8a.), Hct increased approximately by 26% over the control value at the highest aluminium concentration ($520 \mu\text{g l}^{-1}$) after 1 d exposure (Fig.3.8a). An ANOVA performed on 1 d data showed an overall significant treatment effect (0.01). Significant differences compared with control fish, however, were found in fish at $\geq 220 \mu\text{g Al l}^{-1}$, as discerned by LSD-test. By day 4 of exposure, there were further rises in Hct values, being conspicuously elevated from control fish at aluminium concentrations $\geq 170 \mu\text{g l}^{-1}$ and a maximum increase of 49% over control was recorded in fish at $320 \mu\text{g Al l}^{-1}$. The overall action of aluminium was highly significant (<0.001 ; Kruskal-Wallis test). A 4 d response threshold concentration may probably be established between aluminium concentrations 120 and $170 \mu\text{g l}^{-1}$.

As can be seen from Fig.3.7a and 3.8a, the 4 d-exposed fish in both LCW and HCW conditions, in general, had higher Hct-values than fish exposed for 1 d. Significant differences, however, could be detected among fish held in intermediate concentrations of aluminium ($120\text{-}220 \mu\text{g Al l}^{-1}$; t-test) in LCW conditions and at an aluminium concentration of $320 \mu\text{g l}^{-1}$ under HCW conditions. As mentioned earlier, for reasons

of statistical validity, the results from LCW and HCW experiments could not be statistically compared. However, visual inspection of data shows that, in general, each group of aluminium treated fish in LCW had higher Hct-value than the corresponding group of fish in HCW, particularly at the lower aluminium concentrations.

Plasma Glucose

The effects of acid/aluminium exposure on plasma glucose levels measured during LCW and HCW experiments are documented in Figs.3.7b & 3.8b., respectively. Glucose concentration was somewhat elevated, albeit insignificantly, under acidic water in LCW conditions.

Plasma glucose concentrations increased progressively with increasing aluminium concentration in the exposure media, being significantly different from control at aluminium concentration ≥ 170 and $\geq 120 \mu\text{g l}^{-1}$ on day 1 and day 4 of exposure, respectively, (LSD test) reaching a maximum approximately 5-6 times greater than the control value at $320 \mu\text{g Al l}^{-1}$ fish after 4 d exposure (Fig.3.9b). The overall effect of aluminium on both day 1 and day 4 of exposure was significant at $P < 0.001$ (One-way ANOVA). A 4 d response threshold concentration of aluminium for plasma glucose probably exists between aluminium concentrations 70 and $120 \mu\text{g Al l}^{-1}$ under LCW conditions. Plasma glucose concentrations were found to increase in an approximately linear manner in fish held for 4 days at a rate $103 \text{ mmol l}^{-1}/\text{mg Al l}^{-1}$ in the aluminium range 120 - $220 \mu\text{g l}^{-1}$. As aluminium concentration increased from 220 to $320 \mu\text{g l}^{-1}$ the corresponding rate of glucose increase was only approximately $28 \text{ mmol l}^{-1}/\text{mg Al l}^{-1}$.

There also occurred progressive elevations in plasma glucose levels in HCW experiments (Fig.3.8b.) and overall ANOVA indicated significant action of aluminium both on day 1 and on day 4 data ($P < 0.001$). Compared with control fish, however,

significant differences were observed in fish at aluminium concentrations ≥ 220 and $\geq 170 \mu\text{g l}^{-1}$ after 1 d and 4 d exposure, respectively (LSD-test). Thus, a 4 d response threshold concentrations for glucose under HCW conditions appears to lie between aluminium concentrations 120 and $170 \mu\text{g l}^{-1}$. The increase in plasma glucose concentrations between aluminium concentrations 120 and $220 \mu\text{g l}^{-1}$ and between aluminium concentrations 220 and $320 \mu\text{g l}^{-1}$ were 48 and 44 $\text{mmol l}^{-1}/\text{mg Al l}^{-1}$ respectively. However, as aluminium concentration increased from 320 to $520 \mu\text{g l}^{-1}$ plasma glucose increased at a much reduced rate ($17 \text{mmol l}^{-1}/\text{mg Al l}^{-1}$).

As can be seen from Figs.3.7b & 3.8b. each group of aluminium-exposed fish in LCW, in general, had higher glucose level than the corresponding group of fish in HCW. In both exposure conditions (LCW and HCW), exposure duration also affected plasma glucose levels in fish at certain treatment conditions (t-test) (Figs. 3.7b & 3.8b).

Plasma Osmolality

Figs.3.7c. & 3.8c. demonstrate the effects of acid/aluminium exposure on plasma osmolality during experiments with LCW and HCW, respectively. Exposure to acid conditions alone did not affect plasma osmolality either during LCW or HCW experiments.

After 1 d exposure during LCW experiments (Fig.3.7c.), plasma osmolality was considerably reduced at aluminium concentrations $\geq 170 \mu\text{g l}^{-1}$ but significant differences with control fish could only be detected at the highest aluminium concentration ($320 \mu\text{g l}^{-1}$) (LSD-test) and a 7% drop in plasma osmotic value was noted in this group of fish. An ANOVA test performed on 1 d data showed significant action of aluminium at $P < 0.01$. By day 4 of exposure under LCW conditions, plasma osmolality declined progressively with increasing aluminium concentration, being

significantly different at aluminium concentrations $\geq 170 \mu\text{g l}^{-1}$ and reaching a 21% decrease in plasma osmolality at the highest aluminium concentration compared with control fish. The overall action of aluminium was highly significant ($P < 0.001$; one-way ANOVA). Between aluminium concentrations 120 and 220 $\mu\text{g l}^{-1}$ plasma osmolality declined in an approximately linear manner such that the rate of plasma osmolality decrease was approximately 325 mosmol $\text{l}^{-1}/\text{mg Al l}^{-1}$. As the ambient aluminium concentration increased from 220 to 320 $\mu\text{g l}^{-1}$, the corresponding rate of loss in osmotic value was approximately 200 mosmol $\text{l}^{-1}/\text{mg Al l}^{-1}$. Considering the changes in plasma osmolality, it appears that a 4 d response threshold concentration for osmotic breakdown under LCW conditions, thus, exists somewhere between aluminium concentrations 170 and 220 $\mu\text{g Al l}^{-1}$.

During HCW experiments (Fig.3.8c.), a significant decrease in plasma osmolality was observed only in fish at 520 $\mu\text{g Al l}^{-1}$ after 1 d exposure (LSD test). By day 4, however, a significant drop in plasma osmolality was observed at aluminium concentrations $\geq 320 \mu\text{g l}^{-1}$ fish, compared with control fish. A 4 d response threshold concentration under HCW conditions probably lies between aluminium concentrations 220 and 320 $\mu\text{g l}^{-1}$. Plasma osmolality reduced at a rate of approximately 87 mosmol $\text{l}^{-1}/\text{mg Al l}^{-1}$ between aluminium concentrations 120-220 $\mu\text{g l}^{-1}$. However, when aluminium concentration was increased from 220 to 520 $\mu\text{g l}^{-1}$, the corresponding decrease in plasma osmolality was 132 mosmol $\text{l}^{-1}/\text{mg Al l}^{-1}$.

It appears from the data that high aluminium concentrations in the media reduced the osmotic loss in fish, particularly at higher aluminium concentrations. In certain comparisons, exposure duration significantly affected plasma concentrations under acid/aluminium stress (see Figs. 3.7c & 3.8c).

Plasma Sodium

Figs.3.9a. & 3.10a. show the effects of acid/aluminium exposure on changes in plasma sodium levels in tilapia in LCW and HCW, respectively. Acidic water used in the present study did not exert any significant influence on plasma sodium concentrations either during LCW or during HCW experiment. In general, plasma sodium concentration declined progressively with increasing aluminium concentrations in the media.

One day after aluminium exposure under LCW conditions (Fig.3.9a.), the maximum decrease (approximately 11% below the control fish) was observed in fish at the highest aluminium concentration ($320 \mu\text{g Al l}^{-1}$). The results from the ANOVA test showed that overall aluminium action was significant at $P < 0.001$ and a posteriori LSD-test indicated that only the above group of fish was significantly different from the control fish. By day 4 of exposure, plasma sodium had fallen to around $117 \text{ mmol l}^{-1}/\text{mg Al l}^{-1}$ in the worst-affected group of fish, a level 24% below that found among control fish. The overall action of aluminium was also highly significant ($P < 0.001$). Significant differences, however, were observed in fish held at aluminium concentrations $\geq 170 \mu\text{g l}^{-1}$ (LSD-test). Plasma sodium decreased at a rate of $143 \text{ mmol l}^{-1}/\text{mg Al l}^{-1}$ between aluminium concentrations 120 and $220 \mu\text{g l}^{-1}$ while the rate between aluminium concentrations 220 and $320 \mu\text{g l}^{-1}$ was $108 \text{ mmol l}^{-1}/\text{mg Al l}^{-1}$. A 4 d response threshold concentration under LCW conditions appears to exist between aluminium concentrations 70 and $120 \mu\text{g l}^{-1}$.

By day 1 under HCW conditions (Fig.3.10a), exposure to aluminium concentrations $\leq 320 \mu\text{g l}^{-1}$ did not affect plasma sodium concentrations significantly compared with control fish, although the levels were found to decrease by a considerable extent. Fish held at $520 \mu\text{g Al l}^{-1}$ had significantly lower concentrations of plasma sodium (approximately 8% below the control value) at this stage. Fish exposed for 4 d in HCW

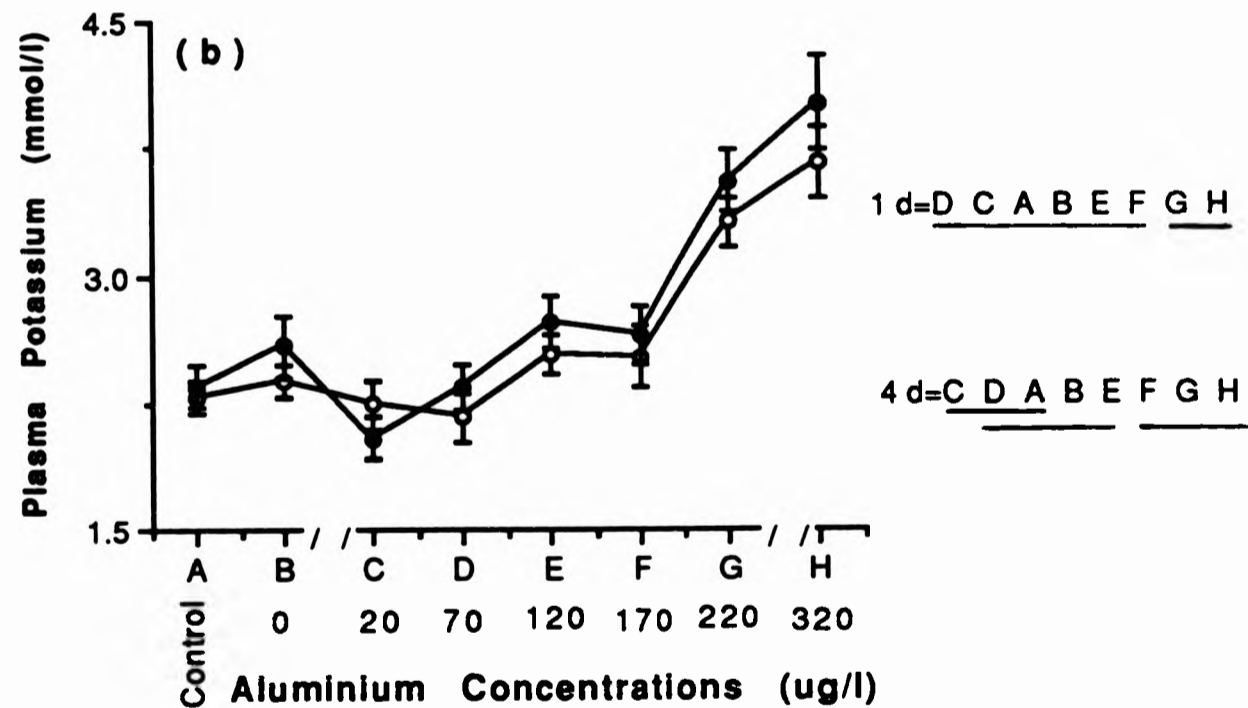
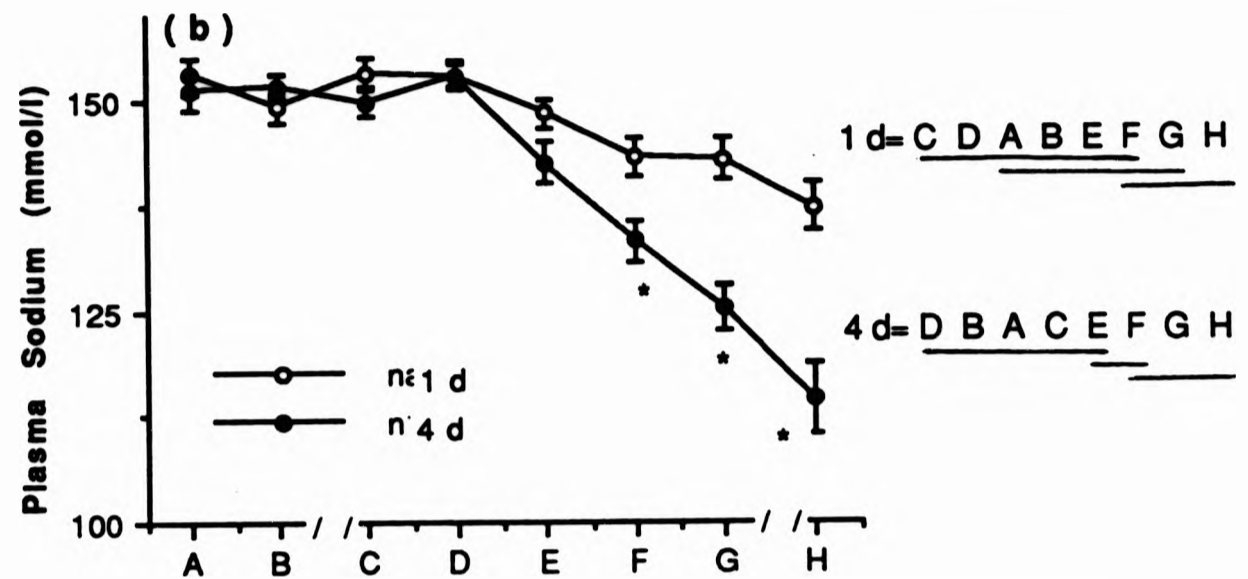

Fig. 3.9. Changes in plasma (a) sodium and (b) potassium concentrations in tilapia after 4 d exposure to different aluminium concentrations at pH 5.2 in LCW conditions. Vertical bars indicate \pm S.E. (n=8). Letters under same line are not significantly different. Asterisks show significant differences from corresponding 1 d samples.

conditions also showed a progressive decline in plasma sodium, being significantly different at aluminium concentrations $\geq 320 \mu\text{g l}^{-1}$. As can be seen from Fig.3.10a. a more conspicuous decrease in sodium concentration was evident between aluminium concentrations 320 and $520 \mu\text{g l}^{-1}$.

It appears from Fig.3.9a & 3.10a. and also from the above calculated rates of decrease in sodium that higher levels of calcium in the exposure media reduced sodium loss in fish during acid/aluminium exposure, particularly at lower aluminium concentrations. It is also evident that, in general, 4 d-exposed fish either in LCW or HCW conditions had lower sodium levels than fish exposed for 1 d in each calcium condition and were found to be significantly different in certain comparisons (t-test) (see Figs.3.9a & 3.10a).

Plasma Potassium

Figs.3.9b. & 3.10b. show changes in plasma potassium concentrations in tilapia during LCW and HCW experiments, respectively. Plasma potassium concentrations were not affected by exposure to acid alone. Exposure to elevated levels of aluminium increased potassium levels in plasma. However, the increases in potassium concentrations were not proportional to exposure aluminium concentrations.

While there was little change in plasma potassium concentrations in fish exposed to $\leq 170 \mu\text{g Al l}^{-1}$, fish exposed to aluminium concentrations ≥ 220 showed a marked and significant change (45% increase at $220 \mu\text{g Al l}^{-1}$ over control value) in potassium by day 1 of exposure under LCW conditions. However, after day 4 of exposure potassium concentrations increased significantly in fish exposed to $\geq 170 \mu\text{g Al l}^{-1}$ (LSD-test). As much as a two-fold increase in plasma potassium level was recorded in fish held at the highest aluminium concentrations ($320 \mu\text{g l}^{-1}$). A 4 d response threshold

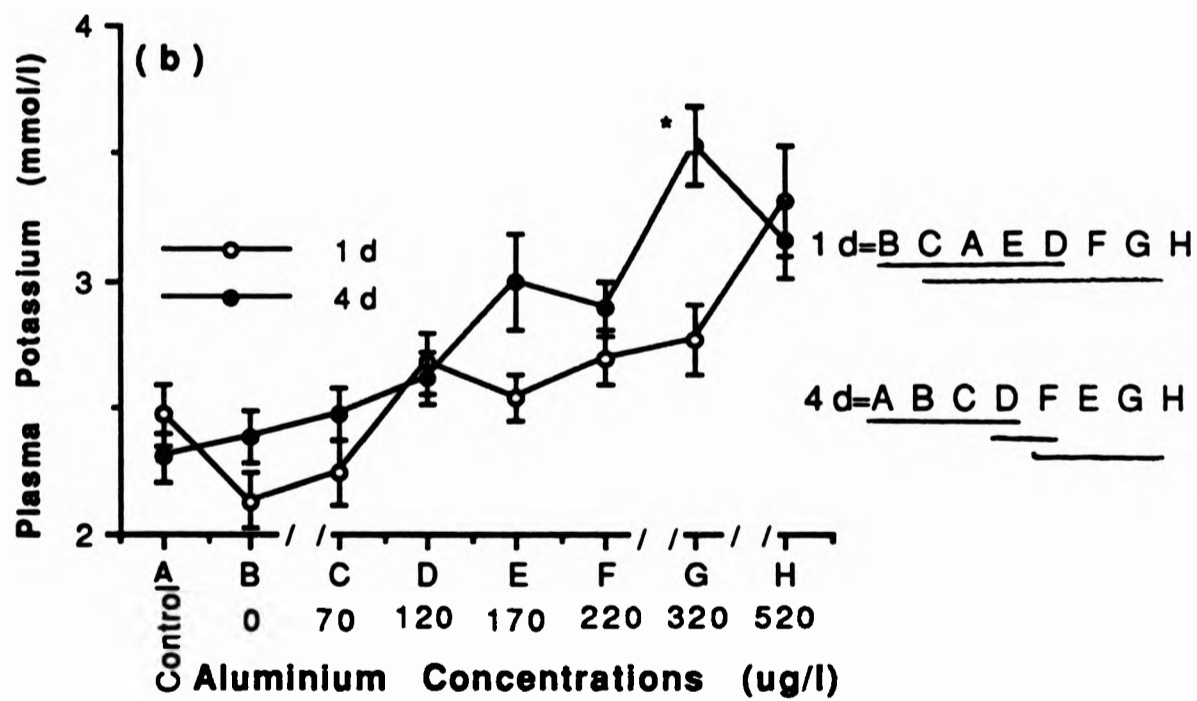
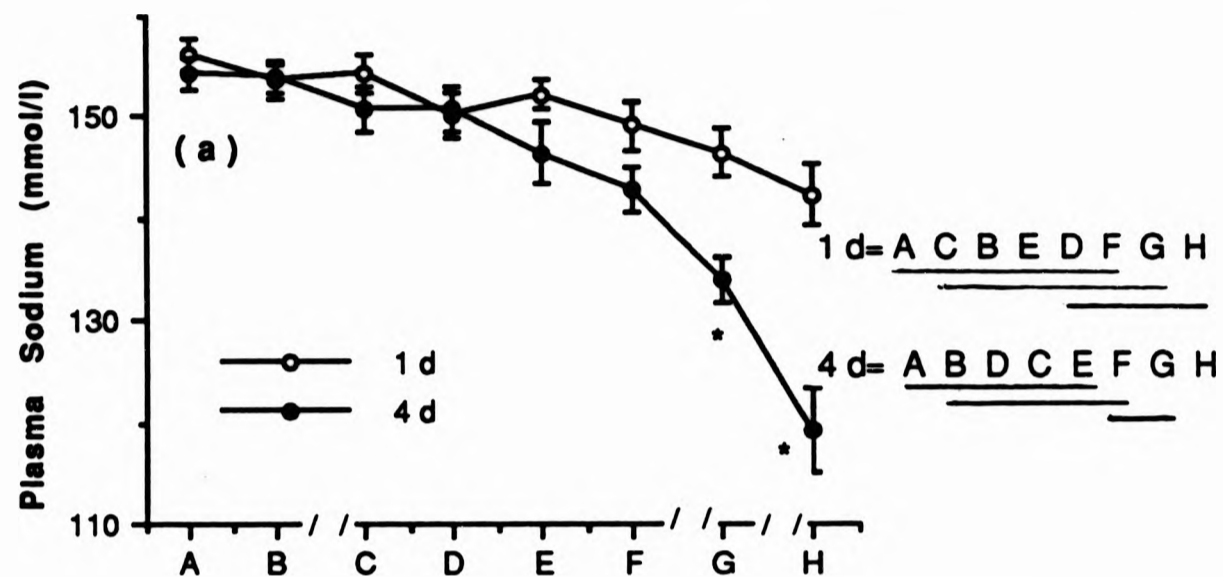

Fig. 3.10. Changes in plasma (a) sodium and (b) potassium concentrations in tilapia after 4 d exposure to different aluminium concentrations at pH 5.2 in HCW conditions. Vertical bars indicate \pm S.E. (n=8). Letters under same line are not significantly different. Asterisks show significant differences from corresponding 1 d samples.

concentration may, therefore, be set between aluminium concentrations 120 and 170 $\mu\text{g l}^{-1}$ in LCW conditions.

In HCW experiments (Fig.3.10b.), exposure to 320 $\mu\text{g Al l}^{-1}$ resulted in a marked, but insignificant, increase (22% increase over control value) in plasma potassium levels. However, compared with control fish, a significant difference was observed only in fish group exposed to 520 $\mu\text{g Al l}^{-1}$ (LSD-test). By day 4 of exposure, however, the levels increased significantly in fish exposed to $\geq 170 \mu\text{g Al l}^{-1}$. A 4 d threshold concentration of aluminium lies somewhere between aluminium concentrations of 120 and 170 $\mu\text{g l}^{-1}$ under HCW conditions.

There was little variation in plasma potassium concentrations between LCW and HCW fish except in fish exposed to higher aluminium concentrations. In certain comparisons, exposure duration was found to significantly affect plasma levels of potassium (see Figs.3.9b & 3.10b).

3.3.3.4. Muscle Tissue Parameters

Muscle Sodium

The results of muscle tissue sodium measurements made on day 4 samples during LCW and HCW experiments are presented in Figs.3.11 a and 3.12a, respectively. Muscle sodium concentrations were not affected by acid exposure alone. However, in both LCW and HCW experiments, acid/aluminium exposure significantly reduced tissue sodium concentrations (One-way ANOVA; $P < 0.001$).

In comparison with control fish, tissue sodium content was significantly reduced by aluminium concentrations of $\geq 220 \mu\text{g l}^{-1}$ (LSD-test) under LCW conditions (Fig.3,11a). The highest reduction (44% below control value) was recorded in fish at 320 $\mu\text{g Al l}^{-1}$

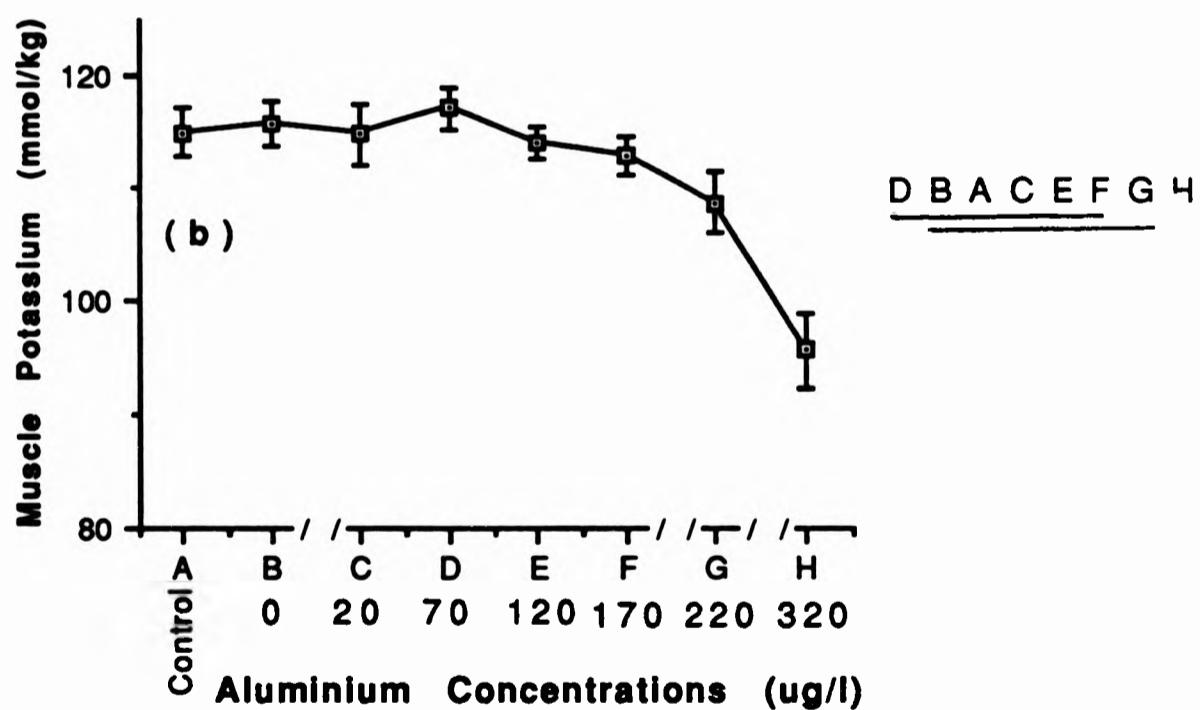
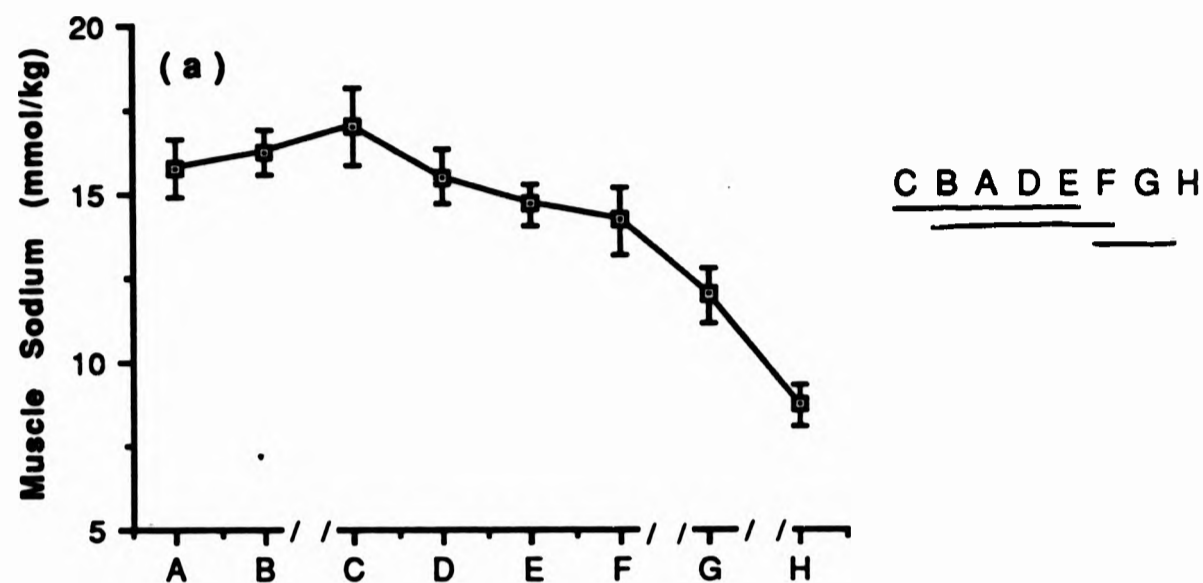

Fig.3.11. Changes in muscle tissue (a) sodium and (b) potassium concentrations in tilapia exposed to acid/aluminium for 4 days during experiments with LCW conditions. Vertical bars indicate \pm S.E. (n= 6-7). Letters under by same line are not significantly different (LSD-test; P <0.05).

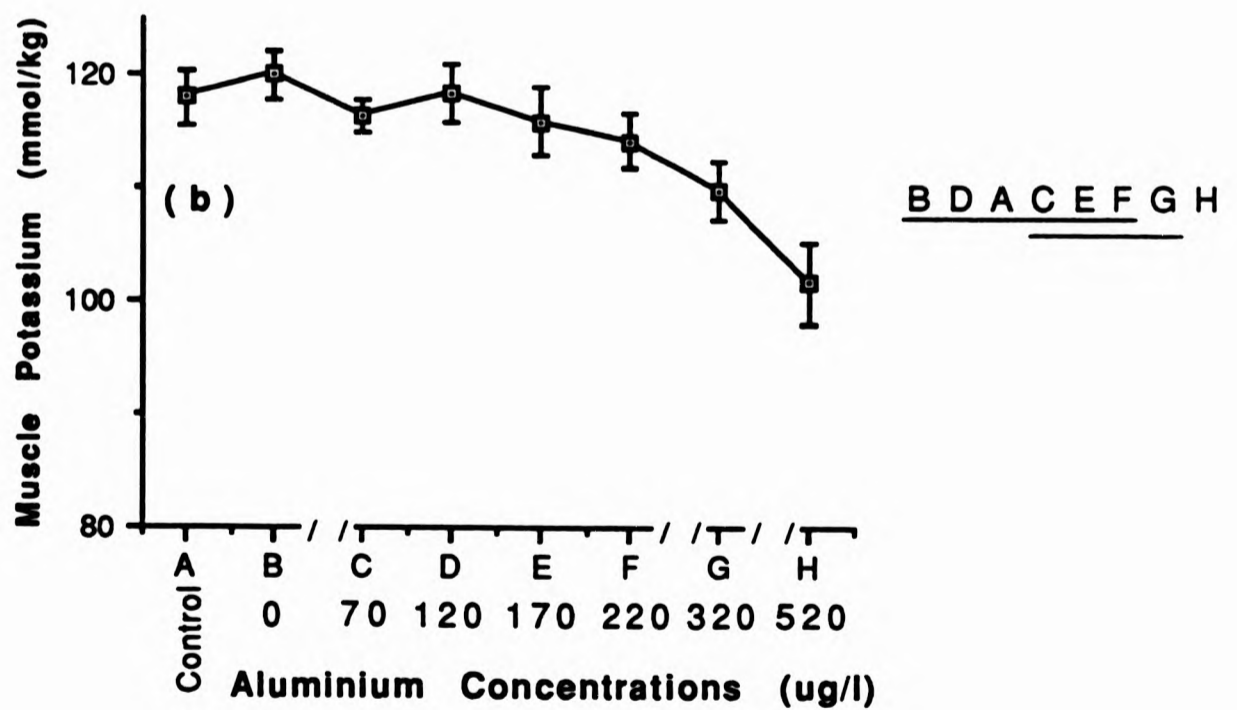
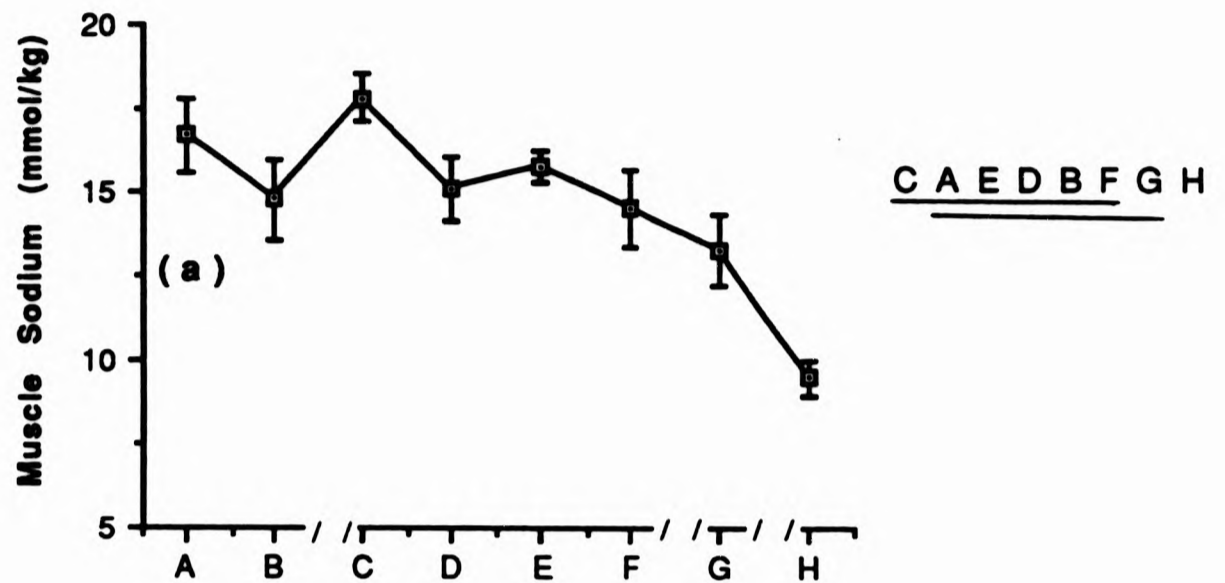

Fig.3.12. Changes in muscle tissue (a) sodium and (b) potassium concentrations in tilapia exposed to acid/aluminium for 4 days during experiments with HCW conditions. Vertical bars indicate \pm S.E. (n= 6-7). Letters under by same line are not significantly different (LSD-test; $P < 0.05$).

¹. A 4 d response threshold concentration of aluminium, therefore, lies somewhere between aluminium concentrations of 170 and 220 $\mu\text{g l}^{-1}$. Similarly, during experiments with HCW, such reductions in muscle tissue sodium concentrations were observed in fish exposed to $\geq 320 \mu\text{g Al l}^{-1}$ (LSD-test) (Fig.3.12a) and a response threshold concentration of aluminium in this case thus probably exists between aluminium concentrations 220 and 320 $\mu\text{g l}^{-1}$. It is, therefore, evident from the results that losses in muscle sodium are greater in a LCW environment at a given exposure condition.

Muscle Potassium

Figs. 3.11b and 3.12b demonstrate the changes in tissue potassium concentrations observed during LCW and HCW experiments, respectively. As with other parameters, tissue potassium concentrations remained unaffected by acid exposure alone and were significantly affected under acid/aluminium exposure conditions (One-way ANOVA; $P < 0.001$).

Under LCW conditions, a 17% reduction in muscle potassium content occurred in fish at the highest aluminium concentration (320 $\mu\text{g Al l}^{-1}$) and compared with control fish significant differences could only be detected in this group of fish (LSD-test). However, under conditions of HCW, fish groups exposed to 320 and 520 $\mu\text{g Al l}^{-1}$ showed significant decreases in muscle potassium concentrations at aluminium concentrations $\leq 320 \mu\text{g l}^{-1}$. A 4 d response threshold concentration of aluminium may be set between aluminium concentrations 220 and 320 $\mu\text{g l}^{-1}$.

3.3.3.5. Aluminium Content in Gill Tissue

The results from measurements of aluminium accumulation in gills after 4 d exposure are documented in Table-3.6. In general, tissue analyses showed increasing levels of aluminium in and/or on the gills with increasing concentrations of aluminium in the

exposure media. Visual inspection of data revealed no marked differences in gill tissue aluminium content between LCW and HCW fish and no particular trend emerged from the results.

exposure media. Visual inspection of data revealed no marked differences in gill tissue aluminium content between LCW and HCW fish and no particular trend emerged from the results.

Table-3.6: Gill aluminium content ($\mu\text{g Al g}^{-1}$ dry tissue) in tilapia after 4 d exposure to acid/aluminium under LCW and HCW conditions. Values are arithmetic means \pm S.D. (n=7-8).

Aluminium conc in media ($\mu\text{g/l}$)	Aluminium content in gills ($\mu\text{g/g}$ dry tissue)	
	LCW	HCW
0	23 \pm 15	17 \pm 12
20	58 \pm 19.	-----
70	135 \pm 40	68 \pm 25
120	182 \pm 29	141 \pm 38
170	287 \pm 77	198 \pm 91
220	268 \pm 97	353 \pm 87
320	514 \pm 168	601 \pm 229
520	-----	667 \pm 243

3.4. DISCUSSION

This study is the first which assesses the physiological response of a tropical fish species to aluminium and evaluates the influence of external calcium in ameliorating the toxic effect using a series of aluminium and calcium concentrations under controlled laboratory conditions. The measurement of a large number of blood parameters and simultaneous observations made on tissue electrolyte levels provides some insight not only into the functional and homeostatic involvement of each parameter but also helps to interpret the interaction of various parameters under different exposure conditions. Additional observations made on behavioural responses provide further insight into the understanding of toxic mechanisms in fish under acid/aluminium stress. Such a comprehensive approach towards improving understanding and characterization of osmoregulatory changes in fish during acid/aluminium exposure was clearly important.

3.4.1. Water Quality

Other than sodium (see below), near nominal concentrations of measured parameters were consistently achieved. The slight differences in some parameters among tanks and different experimental trials may be due to variability in pumping efficiency between channels in the multichannel peristaltic pump. Slightly depressed levels of aluminium in high aluminium treatment tanks were observed. This may be due to adsorption and precipitation. Actual sodium levels in the exposure media increased much more than intended. The introduction of additional sodium occurred partly through the acid-base titration for maintaining pH in the system header tank and partly as a result of pH adjustment of aluminium stock solution. The fluctuations in water sodium probably had minimal influence on the overall results because they occurred simultaneously in all exposure tanks. Furthermore, Brown (1981) and Dalziel (1985) found no effect of water sodium over the range variation noted here on the toxicity of acid or acid/aluminium

to brown trout.

3.4.2. Fish Behaviour and Physical Appearance

Hyperactivity following exposure to heavy metals is a familiar behavioural response to heavy metals and can be attributed to a 'general excitation' of activity (Steele, 1985). Aluminium is a surface active metal (McDonald *et al.*, 1989) and known to cause irritation to surfacial tissue (Tandjung, 1982). Therefore, the observed initial hyperactivity in tilapia upon exposure to acid/aluminium conditions seems typical of generalized reaction to an irritant.

Excessive mucus production and sloughing of secreted mucus from the fish body, particularly in fish exposed to higher aluminium concentrations and LCW conditions, were important observations made in the present study. Secretion of excess mucus following exposure to acid/aluminium conditions is a widely observed response in fish (Muniz and Leivestad, 1980; Saleh, 1986; Wood *et al.*, 1988a; Booth *et al.*, 1988; Handy and Eddy, 1989; Handy *et al.*, 1989). As a surface active irritant, aluminium probably induces an inflammatory reaction in fish, and in turn, this probably stimulates mucus production (Wood and McDonald, 1987; Wood *et al.*, 1988a; Playle *et al.*, 1989). In normal condition, mucus protects the fish from osmotic stress and also acts as a defense mechanism (reviewed by Mallat, 1985)

Body mucus is a polyelectrolyte with fixed negative charges (Kirschner, 1978; Oschman, 1978) and provide binding sites for cations, including calcium (Handy and Eddy, 1989; Handy *et al.* 1989). Aluminium has been shown to compete for binding sites in mucus at the gill and, thus, reducing their abundance in the mucus (Handy and Eddy, 1989; Handy *et al.*, 1989). It is also known that aluminium acts as an astringent and precipitates biological molecules (Tandjung, 1982; Dentel and Gosset, 1988). Once

the mucus binding sites are saturated with aluminium ions, precipitated mucus is replaced by fresh mucus in the process of removal of aluminium from the gill and body surface (Handy *et al.*, 1989). In calcium poor water or in the presence of excess aluminium ions most of the binding sites may be occupied by aluminium and may enhance the process of precipitation and its subsequent sloughing of from the body. This may explain why mucus sloughing is predominantly seen in aluminium-exposed fish under LCW conditions.

The loss of body mucus may have several consequences. First, mucus secretion involves an energetic cost. Second, excess mucus secretion may eventually exhaust the mucus reserves, as is evident from the histological observations made in the present study (Chapter 7). Third, since secreted mucus contains a number of ions (Handy and Eddy, 1989), the loss of large quantities of body mucus may result in depletion of ions which may be a contributing factor in acid/aluminium toxicity. However, secretion of mucus is advantageous in fish exposed to low levels of aluminium or for a short period of time.

Other symptoms of acid/aluminium exposure observed in the present study, which included gaping of the mouth, air gulping and crowding near the water inlet, signify respiratory distress. Respiratory imbalance is also considered as one of the important toxic modes of action in acid/aluminium toxicity. Reviewers' consensus suggest that respiratory problems are likely to occur in acid/aluminium-exposed fish under higher water calcium conditions (Wood and McDonald, 1987; Wood, 1989). In the present study, however, the symptoms of respiratory distress were also observed in LCW fish, particularly in fish exposed to higher aluminium concentrations. Nonetheless, such symptoms were more pronounced in HCW fish. The secretion of excess mucus and the observed mucous coat in some groups of fish may act as a barrier to oxygen diffusion.

Moreover, the increased metabolic cost due to hyperactivity and mucus secretion may exacerbate oxygen requirements. The observed behavioural response and physical appearance of fish in the present study seems to be consistent with physiological data obtained during the course of the study.

3.4.3. Blood and Tissue Parameters

Effects of acid-alone exposure

As expected, exposure of tilapia to pH 5.2 induced no noticeable changes in any parameter investigated during the present study (Experiment Series 3). Indeed, tilapia is considered as an acid-resistant species, having a good degree of adaptive capacity, in particular with respect to osmoregulation in acidic environment (Balm, 1986; and see also review by Wendelaar Bonga and Balm, 1989). Tilapia, *Oreochromis mossambicus*, held at pH 5.0 did not show significant change in plasma concentrations of sodium and calcium, and plasma osmolality during a 40 d exposure period (Wendelaar Bonga *et al.*, 1984a). Even at pH 4.0, the changes in above parameters were only transitory. Branchial water and ion permeability were also unaffected at pH 5.0 in the same study. Balm *et al.* (1987) also could not demonstrate any significant changes in plasma sodium concentrations and plasma osmolality in tilapia exposed to pH 3.5 for 3 d, although plasma glucose concentrations and blood haematocrit (Hct) were significantly affected. A number of other studies reported that metabolic functions of tilapia were little affected during exposure to pH 5.0 for varying periods of exposure (Bhaskar *et al.*, 1978; Murthy *et al.*, 1981; Bhaskar and Govindapa, 1985). Even the more acid sensitive salmonids are also little affected by acid exposure (pH \geq 4.8) as evidenced by flux measurement, ionoregulatory and respiratory studies (Staumes *et al.*, 1984b; Dalziel *et al.*, 1986; Booth *et al.*, 1988; Goss and Wood, 1988). Therefore, the pH of 5.2 chosen for the present study was unlikely to cause any noticeable changes in physiology of such an acid tolerant species as tilapia.

Effects of acid/aluminium exposure

This study confirms the ionoregulatory and haematological disturbances caused by acid/aluminium exposure and clearly demonstrate the influence of external calcium in the amelioration of toxic effects.

The observed increases in Hct at the elevated levels of aluminium (Experiment Series 3 and Experiment 2; Figs. 3.3a, 3.7a and 3.8a) accord with the results of previous studies on salmonids, subjected to acute exposure of acid/aluminium, both under low and high calcium conditions (Witters, 1986; Malte, 1986; Jensen and Weber, 1987; Wood *et al.*, 1988a; Goss and Wood, 1988; Witters *et al.*, 1990). Increases in Hct in fish under conditions of stress could result from a number of mechanisms involved, i.e. a decrease in plasma volume, erythrocyte swelling and an increase in the number of erythrocytes, each of which may act singly or in combination (Milligan and Wood, 1982). Although no direct measurement of plasma volume was made in the present study, increases in total plasma protein (see below) indicate that some degree of reduction in plasma volume probably had occurred and, thus, might have partly contributed to the observed increased Hct-value. The possibility of Hct increases due to erythrocyte swelling is strongly supported by the observed decrease in calculated mean cell haemoglobin concentration (MCHC) in experiment 2 (see below). Increased number of erythrocytes in circulation have been reported in acid/aluminium-exposed fish (Malte, 1986; Witters *et al.*, 1987). Although this was not observed by Witters (1986) in rainbow trout exposed to acid/aluminium conditions, it is argued that this was due to the short exposure period. Any increases in erythrocyte count may result from changes in plasma volume and/or entry of new erythrocytes into circulation. Several studies have shown the increased abundance of reticulocytes in fish under acid stress condition (Milligan and Wood, 1982; Stuart and Morris, 1985) indicating the

mobilization of new erythrocytes from the spleen. It is generally believed that catecholamine induced splenic contraction helps to release erythrocytes from the spleen into circulation (Milligan and Wood, 1982). Elevation in circulating catecholamine levels has been reported in rainbow trout exposed to acid/aluminium conditions (Goss, G.C., Playle, R.C. and Wood, C.M.; unpublished results quoted by Playle *et al.*, 1989). Recently, Witters *et al.* (1991) have also noted a 10-fold increase in circulating catecholamine levels in acid/aluminium-exposed fish. Although no enumeration was made on erythrocyte number in the present study, it appears from the above discussion that an increase in erythrocyte number might have occurred and probably has contributed partly to Hct increase.

As can be seen from Figs. 3.7a and 3.8a, the Hct-value increased progressively after exceeding threshold concentration both under LCW and HCW conditions. It appears a particularly sensitive parameter, being affected by low levels of aluminium. However, at higher aluminium concentrations the relative increase in Hct-value is small indicating that, perhaps, there is a maximum response limit beyond which additional aluminium has little effect on haematocrit increase.

Blood haemoglobin (Hb) level was measured only in Experiment 2 and found to be elevated at the highest aluminium concentration, both in LCW and HCW fish (Fig. 3.3.1b). Increases in Hb concentration in fish under acid/aluminium stress have previously been reported by some workers (Malte, 1986; Goss and Wood, 1988; Wood *et al.*, 1988a) while others (Witters, 1986; Wood *et al.*, 1988b) did not find any significant changes. This discrepancy is, again, probably attributable to short-term exposure (Witters, 1986) and the low level of exposure aluminium concentration (Wood *et al.*, 1988b). The changes observed in Hb concentrations in the present study are more or less consistent with the increase in Hct-value, although changes in Hb concentration

were less than that could be expected from the corresponding increases in Hct and thus again support the view of erythrocyte swelling and entry of Hb-poor erythrocytes into circulation.

In agreement with the present study a reduction in MCHC-value (Fig. 3.3c) has been almost universally observed in previous studies (Witters, 1986; Malte, 1986; Jensen and Weber, 1987; Goss and Wood, 1988; Wood *et al.*, 1988a; Wood *et al.*, 1988b; Wood *et al.*, 1988c) during acute and chronic exposure of fish to acid/aluminium. A fall in MCHC-value indicates swelling of erythrocytes probably resulted from entry of fluid into the blood cells in response to osmotic inequilibrium caused by the decrease in plasma ions (Milligan and Wood, 1982). Decreases in main plasma electrolyte sodium and a concomitant drop in plasma osmolality recorded in the present study support this view. In addition, another possibility of decrease in MCHC-value could be due to β -adrenergic swelling of erythrocytes caused by the release of catecholamines into blood. In dogfish, the release of catecholamines increases in response to hypoxic stress (Butler *et al.*, 1978) and other forms of stress have the same effect on fish (Nakano and Tomilson, 1967). Catecholamines increase red blood cell volume and intracellular pH and consequently increase the oxygen affinity of Hb (Nikinama, 1983). This is an important response in a situation of falling blood pH and increasing diffusion distance. As mentioned above, elevation of circulating catecholamines in acid/aluminium-exposed fish reported in a previous study (see Playle *et al.*, 1989), reported fall in blood pH (see Section 1.4.1.3) and observed symptoms of respiratory distress in the present study (Experiment Series 3) indicate such an effect on erythrocyte swelling observed in the present study. As discussed above, further reductions in MCHC-value may result from the release of Hb-poor erythrocytes into circulation.

In the present study (Experiment 2; Fig. 3.4a) increased total plasma protein was

observed only in fish exposed to higher aluminium concentrations. Similar findings have also been reported by Wood *et al.* (1988a) and Goss and Wood (1988) in acutely acid/aluminium-exposed rainbow trout. Although apparently Wood *et al.* (1988b) did not observe any significant changes in total plasma protein concentration in acid/aluminium-exposed fish, this is not contradictory, since an aluminium concentration similar to the highest aluminium concentration used in that study ($150 \mu\text{g l}^{-1}$) also did not produce any significant changes in plasma protein in the present study (see Chapter 4). The changes in plasma protein have been suggested to have resulted from changes in plasma volume caused by ionic disturbances (Milligan and Wood, 1982). A similar explanation probably applies to the plasma protein increase observed in the present study in the face of falling osmolality.

Acid/aluminium exposure consistently resulted in a decline in plasma osmolality in all experimental trials. However, this action of acid/aluminium exposure was significant only at aluminium concentrations ≥ 170 and $\geq 220 \mu\text{g Al l}^{-1}$ in LCW and HCW conditions, respectively (Experiment Series 3). A few studies have measured plasma osmolality in acid/aluminium-exposed fish. Witters (1986) and Witters *et al.* (1987) also found a drop in plasma osmolality in acutely acid/aluminium-exposed rainbow trout while Wood *et al.* (1988b) did not observe any significant changes in plasma osmolality. This discrepancy again may be explained by the difference in ambient water quality and exposure aluminium concentrations and exposure duration.

The changes in plasma osmolality in tilapia observed in the present study reflect the net changes in several ions (see below). The data reinforce the view that acid/aluminium exposure enhances ion loss. The decreases in plasma osmolality observed upon acid/aluminium exposure in the present study were less than would be expected from the corresponding decline in plasma sodium and presumed chloride loss.

It is evident from the results that the contribution of plasma sodium towards plasma osmolality in acid/aluminium-exposed fish declined continuously with decreasing sodium levels in the plasma. In control fish, the ratio of sodium/osmolality ranged between 0.48 and 0.50 while that in acid/aluminium-exposed fish varied from 0.45 to 0.49. The reduction in the ratio represents a proportional increase in the concentration of one or more of the constituents that contribute to the remaining portion of the osmotic value. Certainly, the plasma glucose level was one of those whose progressive elevation was noted along with loss of plasma sodium. The low plasma osmolality can induce severe changes of the fluid volume distribution between extracellular and intracellular spaces and in this way cell swelling can occur.

Plasma glucose levels were greatly increased by acid/aluminium exposure in all experimental trials during the present study. Significantly elevated levels of plasma glucose have also been reported by Goss and Wood (1988), Playle *et al.* (1989) Wood *et al.* (1988c) and Wood *et al.* (1988b) in salmonids during acute acid/aluminium exposure.

Increases in plasma glucose concentration are a commonly observed response to stress (Soivio and Okari, 1976; McDonald, 1983a; Wedemeyer and McLeay, 1981). Mobilization of glucose is known to be associated with cortisol (Butler *et al.*, 1978) and catecholamines (see Playle *et al.*, 1989) whose concomitant elevations in plasma have been described as a primary response to most stressors (Donaldson, 1981) including heavy metals (Donaldson and Dye, 1975). Cortisol has manifold physiological effects including the stimulation of gluconeogenesis and protein catabolism (Butler *et al.*, 1978). Goss and Wood (1988) and Wood *et al.* (1988c) found significantly elevated levels of circulating cortisol in fish acutely exposed to acid/aluminium conditions, thus justifying the neuro-endocrinological involvement in glucose release during

acid/aluminium exposure. However, as discussed above, the increase in plasma glucose concentrations at the elevated levels of aluminium may partly be due to reduction in plasma volume.

It is generally thought that under conditions of stress hyperglycaemia may provide additional energy. In addition, it probably serves as a mechanism to maintain plasma osmolality (McDonald *et al.*, 1983; Brown *et al.*, 1984). In the present study, plasma glucose levels were found to increase with decreasing plasma sodium concentrations. Borgstrom (1971) reported a linear inverse relationship between sodium chloride and plasma glucose levels in Atlantic salmon, *Salmo salar*, exposed to deionized water. While the question whether the hyperglycaemia response is a controlled mechanism for osmotic compensation during plasma demineralization or a secondary consequence of impaired neuro-endocrinological and resulting impaired metabolic functions remains unclear, the results of the present study suggest that the main benefit of increased plasma glucose may be the maintenance of plasma osmolality in the face of decreasing ion levels. Plasma glucose levels have long been used as indicators of stress (see Section 3.1) including that caused by heavy metals (Donaldson and Dye, 1975). In the present study, plasma glucose appeared to be a sensitive parameter as indicated by its low threshold concentration levels (≥ 70 and $\geq 120 \mu\text{g Al l}^{-1}$; in LCW and HCW, respectively). The graded response in plasma glucose levels with changes in exposure aluminium and calcium concentrations and its relationship with other parameters, in particular with plasma sodium, observed in the present study once again proved plasma glucose to be a reliable indicator of stress.

Both plasma and muscle electrolyte levels were variously affected by different treatments in the present study. The main plasma electrolyte sodium was greatly reduced by acid/aluminium exposure and this was consistently observed in all

experimental trials. Such an action of aluminium, however, was found to be significantly effective in inducing a drop in plasma sodium at aluminium concentrations of ≥ 120 and ≥ 170 during a 4 d exposure period in LCW and HCW, respectively (Figs. 3.9a & 3.10a). In agreement with the present study a number of other studies (Muniz and Leivestad, 1980; Witters, 1986; Witters *et al.*, 1987; Jensen and Weber, 1987; Goss and Wood, 1988; Playle *et al.*, 1989; Booth *et al.*, 1988; Wood *et al.*, 1988a; Wood *et al.*, 1988b; Wood *et al.*, 1988c; Witters *et al.*, 1990) have also observed reduced plasma sodium concentrations in salmonids acutely exposed to aluminium concentrations ranging from 105 to 1000 $\mu\text{g Al l}^{-1}$. By contrast, Malte (1986) could not demonstrate any significant changes in plasma sodium concentration in rainbow trout exposed to 2 mg Al l^{-1} for 6 d at pH 5.0., although the fish were observed to be severely stressed. This discrepancy may have been resulted from the use of unrealistically high calcium (3.3 mmol l^{-1}) tap water by the author, since increased external calcium concentrations in the exposure media is known to reduce ion loss in acid/aluminium stressed fish (see Chapters 1 & 8).

Loss of body ions is, of course, the result of an imbalance between influx and efflux, the active uptake by the transport ATPases on one hand and the passive permeability of the gills on the other (reviews: Wood, 1989; Potts and McWilliams, 1989) Indeed, in keeping with the above, several flux measurement studies have convincingly shown that acid/aluminium exposure caused an inhibition in influx and stimulated an increase in efflux in fish, resulting in a negative netflux (Dalziel *et al.*, 1986; 1987; Booth *et al.*, 1988; McDonald and Milligan, 1988; Wood *et al.*, 1988b). The observed inhibition of Na^+/K^+ -ATPase activity in acid/aluminium-exposed fish by the present author and also by Staurnes *et al.*, (1984a) supports the reported reduced influx in fish during acid/aluminium exposure. However, at a higher pH (pH 5.2) as used in the present study, the contribution of reduced influx towards the net loss of ions is, probably, small

compared to the greater contribution from increased efflux (see Dalziel *et al.*, 1986; Booth *et al.*, 1988).

Concomitant with the loss of plasma sodium there also occurred a substantial reduction in muscle sodium concentrations (Experiment Series 3; Fig.3.11a & 3.12a). Loss of muscle sodium is believed to be largely from extracellular space as has been shown for acid-exposed fish (Milligan and Wood, 1982; Stuart and Morris, 1985). Release of sodium from muscle tissue is probably a compensatory mechanism in the face of declining plasma sodium concentration as well as for the regulation of cell volume.

As can be seen from the results of Experiment Series 3, the changes in plasma sodium concentrations were not proportional to the aluminium concentrations in the exposure media, particularly at higher aluminium concentrations. The likely explanation for this is changes in fluid volume (i.e. haemoconcentration or haemodilution) as well as differential compensation from muscle sodium under different treatment conditions.

Acid/aluminium exposure induced an increase in plasma potassium concentration in tilapia in the present study and this was consistently observed in all experimental trials. However, the results from the experiment series 3 showed that aluminium concentrations of ≥ 170 and $\geq 220 \mu\text{g l}^{-1}$ in LCW and HCW, respectively, were necessary to obtain significant changes in plasma potassium concentrations. In agreement with the present study, a number of previous studies have also reported changes in plasma potassium concentrations in fish acutely exposed to aluminium concentrations ranging from 105 to 1000 $\mu\text{g l}^{-1}$ in acidic environment (Neville, 1985; Witters, 1986; Malte, 1986; Playle *et al.*, 1989; Wood *et al.*, 1988a; Wood *et al.*, 1988b). Flux measurement studies by Booth *et al.*, (1988), however, have shown that rainbow trout acutely exposed to 333 $\mu\text{g Al l}^{-1}$ in water media comparable to that

employed by Wood *et al.* (*ibid*) and by the present author, suffered a net branchial loss of potassium. This indicates an internal source for the observed increases in plasma potassium in acid/aluminium-exposed fish rather than an increased net uptake of potassium. Consistent with the above view, the present study observed a significant decrease in muscle tissue potassium concentrations in acid/aluminium-exposed tilapia. However, no attempt was taken to calculate the compartmentalized loss of muscle potassium in the present study. However, under acid exposure conditions only such losses of muscle potassium have been shown to occur mainly from intracellular spaces (Stuart and Morris, 1985).

The reduction in intracellular potassium and concomitant rise in plasma potassium concentrations can be seen as consequences of several mechanisms. Many workers have explained the increases in plasma potassium during stress (including acid and acid/aluminium stress) as a compensatory mechanism in an attempt to maintain cell volume in the face of declining osmolality arising from sodium and chloride loss. The most probable way of achieving this is by reducing the total number of solutes in parallel with drop in plasma osmolality, thereby preventing the osmotic uptake of water by the cell (Fugelli and Vislie, 1980; Milligan and Wood, 1982; McDonald *et al.*, 1983; Witters *et al.*, 1986). Indeed, potassium is considered as one of the important osmo-effectors (Fugelli and Vislie, 1980). The other suggested mechanism of increased plasma potassium is the K^+/H^+ exchange as a mechanism for buffering acid intracellularly (McDonald and Wood, 1981; Milligan and Wood, 1982; Malte, 1986). Blood acidosis has been reported in acid/aluminium-exposed fish (Wood and McDonald, 1987; Wood *et al.*, 1988b). A partial contribution towards the increased plasma potassium in the present study may also result from the reduction in plasma volume, particularly at the higher aluminium concentrations as described earlier.

Although the results were not consistent during the present study, in general there was a tendency for plasma calcium to be elevated at the higher aluminium concentrations. This increase in plasma calcium concentrations occurred despite the fact that the exposure of fish at the higher aluminium level (i.g. 300 $\mu\text{g Al l}^{-1}$) resulted in an apparent, but insignificant, decrease in Ca^{2+} -ATPase activity (Chapter 5). A number of previous studies also observed an increase in plasma calcium in salmonids acutely exposed to acid/aluminium condition (Jensen and Weber, 1987; Witters *et al.*, 1987; Playle *et al.*, 1989). In the above studies, aluminium concentrations varied from 200 to 333 $\mu\text{g l}^{-1}$. Conflicting results, however, have been reported by Booth *et al.* (1988) who observed a significant decrease in plasma calcium in brook trout exposed for 24 h at aluminium concentrations of 111 and 333 $\mu\text{g l}^{-1}$. Interestingly no significant changes in calcium netflux were observed in that study. Aluminium tested at 6 $\mu\text{mol l}^{-1}$ (160 $\mu\text{g l}^{-1}$) had also no effect on calcium flux rates (Reader and Morris, 1988). The reasons for these discrepancies are unclear. However, it is clear from the above that acid/aluminium exposure probably does not increase net uptake of calcium. Since muscle calcium levels are not affected by acid/aluminium exposure (see Chapter 6), the increases in plasma calcium, thus appears to be the consequence of two mechanisms. First, a slight reduction in plasma volume, as predicted from the plasma protein concentration observed in the present study (see above), may result in a rise in plasma calcium concentration. Such an effect of aluminium exposure on plasma calcium concentration has been suggested by Jensen and Weber (1987). Alternatively and/or in addition, it may be the mobilization of calcium from internal calcium reserves (skeletal calcium, for example). Indeed, mobilization of scale calcium was observed in a separate study by the present author (see Chapter 6) in tilapia exposed to 220 $\mu\text{g Al l}^{-1}$ for 21 d. A similar phenomenon has been suggested to occur in acid-exposed fish (Audet *et al.*, 1988).

In the present study no appreciable changes in plasma magnesium concentrations were found. Wood *et al.* (1988b) determined the plasma concentrations of magnesium and made observations consistent with the present study. Active uptake or intracellular magnesium might regulate plasma magnesium concentrations. No data on magnesium fluxes under acid/aluminium exposure are currently available. However, Beamish *et al.*, (1975) suggested that membrane, connective tissue or skeletal tissue might release magnesium into the blood of the fish on demand.

This study has clearly shown that acid/aluminium induces ionic loss in fish. The results having been discussed above, the physiological basis of the action of aluminium is further discussed in detail in Chapter 8.

It was the intent of the Experiment Series 3 to approximate the response threshold concentrations of aluminium and to characterize the concentration related response in selected parameters. Response stimulation thresholds to acid/aluminium were observed in all investigated variables. From visual inspection, they may be ranked in order of decreasing sensitivity to acid/aluminium stress as follows: plasma glucose = Hct > plasma sodium > plasma osmolality = tissue sodium > plasma potassium = tissue potassium, both in LCW and HCW conditions. Although, this scheme may reflect the sensitivity of each variable to acid/aluminium, the usefulness of a physiological response as an indicator of the level of stress experienced by fish population will be influenced by a variety of factors ranging from water quality to systemic changes in variability over response range.

The results of the present study revealed the protective action of external calcium against acid/aluminium-induced changes in ionic balance in tilapia. However, the degree of this protection afforded by calcium clearly appears to be related to the exposure

aluminium and calcium concentrations as well as to exposure duration. As can be seen from the results of Experiment 1 (where calcium levels were varied), that although the higher calcium concentrations in exposure media exhibited a significant protective action on plasma sodium and potassium ion balance compared with acid/aluminium-exposed fish maintained at the lower calcium concentration, complete protection was not achieved in any calcium treatment group of fish. However, it is evident from the results of Experiment 2 and Experiment Series 3 that, compared with the control fish maintained at circumneutral pH without aluminium, the higher calcium concentration (16 mg l⁻¹) in the media afforded complete protection against acid/aluminium-induced changes in ion balance only in fish exposed at the lower aluminium concentrations. Further, it is also apparent from the later Experiments (Experiment Series 3) that, in general, higher calcium concentrations (16 mg l⁻¹) in the media shifted the inhibitory threshold concentration range higher when compared with acid/aluminium-exposed fish held in LCW conditions (i.e. it requires a greater concentration of aluminium to bring about a significant change in a measured parameter in fish in HCW to the same extent as observed in fish held in LCW environment). For example, an aluminium concentration of 120 µg l⁻¹ was required to induce a significant change in plasma sodium in LCW fish while a higher aluminium concentration (170 µg l⁻¹) was necessary to obtain a similar change in HCW fish. In agreement with the present results Booth *et al.* (1988) (Ca= 0.5 mg and 8.0 mg l⁻¹; Al= 111 and 333 µg l⁻¹), Wood *et al.* (1988a) (Ca= 0.5 and 8.0 mg l⁻¹; Al= 333 µg l⁻¹) and Wood *et al.* (1988b) (Ca= 0.5 and 8.0 mg l⁻¹) also reported the protective action of external calcium concentrations on acid/aluminium-induced imbalances in plasma ion levels. Similarly, Malte (1986) using high calcium (132 mg l⁻¹; Al= 2mg l⁻¹) tap water did not find any changes in plasma sodium levels and indicated that high calcium concentration in the media probably had protected the fish from ionic loss. However, Witters (1986) (Ca= 0.8 and 2.0 mg l⁻¹; Al= 190 µg l⁻¹) could not demonstrate any significant effect of calcium on

acid/aluminium-induced changes in plasma ions or in ionic fluxes. Consistent with the observed protective effects of external calcium concentrations on ion balance, McDonald and Milligan (1988) and Booth *et al.* (1988) demonstrated the protective effects of calcium on ion fluxes across fish gills although this was not observed by Dalziel *et al.* (1986) (Ca= 0.4 and 2.0 mg l⁻¹). A close examination of the above works suggests that the discrepancies probably arise from differences in exposure conditions and duration, in addition to the differences in fish species. Thus the results of earlier studies are explicable using the findings of the present study. The protective action of calcium on ionic imbalance caused by acid/aluminium is thought to be mediated through the interaction of calcium at the gill surface (Wood and McDonald, 1987; Booth *et al.*, 1988; see also Potts and McWilliams, 1989; McDonald *et al.*, 1989, for reviews). The physiological basis of the protection is discussed in detail in Chapter 8.

External calcium concentration did not appear to reduce the acid/aluminium -induced increases in Hct and blood Hb concentrations in fish exposed to higher levels of aluminium, although such effects were corrected by higher calcium concentrations in fish held in lower aluminium concentrations. Acid/aluminium exposure under high calcium conditions are known to cause greater respiratory distress than among fish held in low calcium environments, particularly at high aluminium concentrations (see Malte, 1986; Wood and McDonald, 1987; Wood *et al.*, 1988a; Wood *et al.*, 1988c). As discussed earlier (above), responses in the above parameters are mainly associated with respiratory adjustments during stress. Therefore, protection against acid/aluminium-induced increases in Hct levels and Hb concentrations are unlikely to occur.

3.4.4. Aluminium Accumulation in Gill Tissue

Concentration-dependent elevation of aluminium concentrations in tilapia gills exposed to different aluminium concentrations were observed in this study. However, since

accumulation of aluminium in tissues is affected by ambient water pH (Karlsson-Norrgrén *et al.*, 1986b), calcium concentration (Playle *et al.*, 1989), aluminium concentrations in the exposure media (Karlsson-Norrgrén *et al.*, 1986b; Booth *et al.*, 1988 and the present study) and also other factors such as fish species and sex, and analytical methods (Berg and Burns, 1985), it is difficult to make direct comparisons with the results of the present study. Nonetheless, considering all the above factors, data on gill aluminium content obtained in the present study agree reasonably with the results of both laboratory- (Neville, 1985; Karlsson-Norrgrén *et al.*, 1986b; Lee and Harvey, 1986; Playle *et al.*, 1989; Booth *et al.*, 1988; Handy *et al.* (1989) and field-based (Hunter *et al.*, 1980; Buergele and Soltero, 1983; Berg and Burns, 1985; Karlsson and Norrgren *et al.*, 1986a) studies.

The accumulated aluminium in gills was mostly, probably, surface, subsurface and mucus bound, as suggested by other workers (Booth *et al.*, 1988; Handy *et al.*, 1989) since no increase in aluminium content in plasma or other internal organs have been observed during acute exposure under comparable exposure conditions (Lee and Harvey, 1986; Booth *et al.*, 1988; Handy *et al.*, 1989). Lee and Harvey (*ibid*) argued that the accumulation of aluminium in internal organs observed in field studies by Buergele and Soltero (1983) and Berg and Burns (1985) could have been because of ingestion with food. Nevertheless, trace amount of aluminium can penetrate the epithelial layer (Karlsson-Norrgrén *et al.*, 1986a; Youson and Neville, 1987) as has been shown by x-ray probe microanalysis and special aluminium staining technique (Exley, 1989).

In the present study, ambient calcium concentrations apparently had no noticeable effect on aluminium accumulation in gill tissues. This observation is in agreement with that of Booth *et al.* (1988) who also did not find any significant difference in gill aluminium content between low and high calcium (0.0125 and 0.2 mmol Ca l⁻¹,

respectively) water fish acutely exposed to elevated levels of aluminium. By contrast, Playle *et al.* (1989) found significantly higher aluminium concentrations in trout gill under low calcium water ($0.025 \text{ mmol Ca l}^{-1}$) conditions compared with fish maintained in high calcium ($0.2 \text{ mmol Ca l}^{-1}$) conditions. The reasons for this discrepancy is, however, not clear. The lack of any significant effect of calcium media concentration on gill aluminium concentration seems contrary to the protection afforded by ambient calcium on the physiological responses observed in the present study (see above). However, histological observations showed greater structural damage to gills in fish under LCW conditions in comparison to fish maintained in HCW conditions (see Chapter 7). Under LCW conditions the repetitive sloughing of mucus may have provided an environment for aluminium to act more intimately at the gill surface, thus causing more damage to the gills. Hence, it is not the absolute amount of aluminium associated with the gill, rather how much aluminium is in actual contact with the gill structure, that is important in determining the degree of the toxic action of fish.

In conclusion, acid/aluminium exposures caused decreases in plasma sodium, and muscle tissue sodium and potassium levels and increased plasma concentrations of potassium and calcium. Similar exposures, however, had little effects on plasma magnesium concentrations. Acid/aluminium exposures increased blood Hct levels, Hb and plasma total protein concentrations. In general, external calcium concentrations proved protective against acid/aluminium-induced changes in the parameters measured, and in particular, on ionic balance. However, the manifestations of these actions of aluminium and calcium were clearly dependent upon exposure conditions. Aluminium concentrations of ≤ 70 and $\leq 120 \text{ } \mu\text{g l}^{-1}$ under LCW and HCW conditions, respectively, did not appear to impair any measured parameter during the present experimental period.

CHAPTER 4
EFFECTS OF CHRONIC ACID/ALUMINIUM EXPOSURE ON SOME OF THE
BLOOD AND TISSUE PARAMETERS OF TILAPIA, *OREOCHROMIS*
***NILOTICUS*.**

4.1. INTRODUCTION

Most fish species have adaptive abilities to modulate their functional and homeostatic mechanisms in response to environmental stressors, including chemical pollutants (Wedemeyer and Macleay, 1981). During acute lethal exposure conditions, stress is severe, deleterious effects are manifested within a short period, and eventually the fish die despite their adaptive efforts or before the adaptive mechanisms become fully operative. However, under conditions of chronic exposure, which is more common in nature, stress is less severe and does not exceed the physiological limit of tolerance. In this situation, the fish may have the opportunity to compromise with its altered environment in order to survive.

Under certain chronic exposure conditions, the toxicant-induced changes in a particular physiological parameter may be evident at the initial period of exposure but the fish may recover partially or completely after prolonged exposure. In some other cases, adaptive responses may not be initially apparent but may appear with increased exposure. Nevertheless, in both instances, however, a new steady state may be reached in the physiological functioning of fish permitting them to survive in the altered environment for a long time. In such cases, temporal changes in the physiological response would be expected.

Chronic exposure of fish to acid/aluminium is comparatively poorly studied. A few studies have demonstrated disturbances in whole body ion balance and growth during chronic exposure lasting from 30 to 60 days (Cleveland *et al.*, 1987; Sadler and Lynam, 1988; Reader *et al.*; 1988; 1989). Anomalies in reproductive biology have also been reported during chronic exposure of brook trout, *Salvelinus fontinalis*, in acid/aluminium exposure conditions (Mount *et al.*, 1988b; McCormick *et al.*, 1989). However, there is

a paucity of information on the effects of chronic acid/aluminium exposure on the blood parameters, although these effects have been extensively studied under acute exposure conditions (Chapter 3). The so far reported results of chronic exposure studies are not very clear. Chronic exposure may (Mount *et al.*, 1988a; Booth *et al.* 1988) or may not (Wood *et al.*, 1988a; 1988b) affect blood parameters. A close scrutiny of relevant papers reveals that such anomalies in the reported results probably originate from differences in exposure duration and the aluminium concentrations used. Use of terminal blood samples in almost all of the previous studies did not allow for characterization of the adaptive responses in fish. A time course study using a number of aluminium concentrations is necessary to characterize responses under chronic exposure conditions.

The purpose of the present study, therefore, was to examine the adaptive responses in tilapia under continuous, long-term exposure to constant pH, calcium and aluminium.

Specific objectives were:

- (a) to characterize the temporal and concentration-dependent responses in a number of blood and tissue parameters;
- (b) to establish whether prolonged exposure to acid/aluminium has any effect on ion balance beyond that which appears as an acute effect, i.e. whether any recovery or acclimation has occurred.

4.2. MATERIALS AND METHODS

Nile tilapia, *O. niloticus*, were used in the present study and all the fish came from a common stock. The source of stock fish, the procedure for their maintenance, pre-exposure acclimation and subsequent acidification schedules were as described earlier (Chapter 2, Sections 2.1, 2.3 & 2.4).

4.2.1. Experimental Protocol and Analytical Methods

Two experimental trials were conducted, one in low calcium water (LCW, i.e. 0.6 mg Ca l⁻¹) and one in high calcium water (HCW, i.e. 16.0 mg Ca l⁻¹). The mean weights of fish used in LCW and HCW experiments were 74.38 ± 3.65g and 68.87 ± 4.30g, respectively. In each trial fish were exposed to acid and acid/aluminium conditions for 21 days. The aluminium concentrations used were 0, 50, 100 and 150 µg l⁻¹ at pH 5.2. On the basis of the short-term experiments it seemed likely that the highest aluminium concentration used would cause considerable stress but would not be lethal. Since no significant changes in measured physiological parameters were observed in acid-exposed fish during short-term exposure and also based on the results of some other previous studies (Bhaskar *et al.*, 1978; Wendelaar Bonga and Dederen, 1986; Wendelaar Bonga *et al.*, 1987), it was decided not to test the fish at circumneutral pH during the present series of experiments.

During each experiment, a group of nine randomly selected fish previously acclimatized either in LCW or HCW was introduced to each of the experimental tanks. The tanks were replicated for each treatment group of fish. The fish were then further acclimated for two days in the exposure tanks under through-flow conditions. Immediately prior to acidification of exposure media, one fish from each tank was sampled, thus making a pooled sample of 6 fish (regarded as day 0 sample). Subsequent acidification and

toxicant dosing schedules followed were as described in Chapter 2 (Section 2.5). Fish were sampled on days 2, 9, and 21 of exposure. Three fish from each tank were removed on each sample date. Water samples were collected at regular intervals in order to determine total aluminium, sodium and calcium. Sampled fish were immediately used for collection of blood, epaxial muscle tissue for tissue electrolytes and gills for aluminium analysis. Collection procedures of the above samples were as described in Chapter 3, Section 3.2.2. Blood samples were analyzed for blood haematocrit (Hct), haemoglobin (Hb), plasma concentrations of total protein, glucose, sodium, potassium, magnesium and calcium, and plasma osmolality. Analytical procedure for all blood and tissue parameters were essentially the same as followed for short-term experiments (Chapter 3, Section 3.2.6). Methods for the analysis of water quality parameters have been described in Chapter 2, Section 2.5.

4.2.2. Statistical Analysis

Data are presented as means \pm standard error (± 1 SE). Before performing any statistical analysis normality of the data and homogeneity of variances were checked as described earlier (Chapter 3). Where necessary, various transformations (e.g. x^4 , $(x+325)^2$, $\log t$) of the data were tried to obtain normality and homogeneity. Means within days were compared using one-way analysis of variance, followed by LSD-test (least significant difference-test) to discern specific differences from the control. Level of significance was accepted at $P \leq 0.05$.

4.3. RESULTS

The results documented here demonstrate the effects of acid/aluminium on various blood and tissue parameters during a 21 day exposure period both in LCW and HCW conditions. The experiments were conducted separately although for convenience the results of both experiments are presented together. Particular attention was paid to the trends in the results of this study.

4.3.1. Water Quality

The results of the selected water quality parameters measured during the LCW and HCW Experiments are shown in Tables 4.1. & 4.2., respectively. As with previous experiments (Chapter 3), actual concentrations of sodium in the exposure media were considerably greater than intended. The source of this variation between actual and nominal sodium concentrations is discussed in Chapter 3. Near nominal values in other parameters were consistently observed in the results of both of the experiments.

4.3.2. Blood Parameters

Blood haematocrit (Hct)

LCW Experiment (Fig. 4.1.a): Fish exposed to 150 $\mu\text{g Al l}^{-1}$ showed a significant increase in Hct-value after two days of exposure compared with the control fish, maintained at 0 $\mu\text{g Al l}^{-1}$ and remained significantly elevated throughout the experimental period. However, a maximum response in Hct-value was recorded in 9 day-exposed fish and thereafter declined to a minimum on day 21 of exposure. Exposure to 100 $\mu\text{g Al l}^{-1}$ also induced progressive elevations in blood haematocrit. Compared with the control fish, however, significant difference was noted only on day 21 of exposure. A similar significant increase was also observed in fish exposed to 50 $\mu\text{g Al l}^{-1}$ at the termination of the experiment (day 21 of exposure). There were no noticeable changes in Hct-value in control fish with exposure time.

Table-4.1. Measured water quality parameters in the exposure media during a 21 day experiment in LCW conditions. Nominal concentrations of calcium and sodium were 0.60 (0.015 mmol/l) and 1.10 mg/l (0.48 mmol/l), respectively. Nominal pH was 5.2. Values are arithmetic means \pm S.D. (n=5-6).

Nominal Al conc. (μ g/l)	Measured water quality parameters			
	Aluminium (μ g/l)	Calcium (mg/l)	Sodium (mg/l)	pH
150	157 \pm 19	0.59 \pm 0.06	1.42 \pm 0.09	5.13 \pm 0.15
100	96 \pm 11	0.58 \pm 0.08	1.40 \pm 0.12	5.18 \pm 0.07
50	52 \pm 7	0.54 \pm 0.06	1.46 \pm 0.09	5.16 \pm 0.07
0	1 \pm 1	0.58 \pm 0.08	1.32 \pm 0.11	5.19 \pm 0.11

Table-4.2. Measured water quality parameters in the exposure media during a 21 day experiment in HCW conditions. Nominal concentrations of calcium and sodium were 16.00 (0.4 mmol/l) and 1.10 mg/l (0.48 mmol/l), respectively. Nominal pH was 5.2. Values are arithmetic means \pm S.D. (n= 5-6).

Nominal Al conc. (μ g/l)	Measured water quality parameters			
	Aluminum (μ g/l)	Calcium (mg/l)	Sodium (mg/l)	pH
150	147 \pm 13	16.09 \pm 1.79	1.49 \pm 0.14	5.09 \pm 0.16
100	93 \pm 11	16.24 \pm 1.56	1.43 \pm 0.09	5.14 \pm 0.09
50	48 \pm 7	15.78 \pm 2.00	1.36 \pm 0.16	5.17 \pm 0.07
0	2 \pm 1	16.02 \pm 1.41	1.45 \pm 0.10	5.16 \pm 0.08

HCW Experiment (Fig. 4.1a'): Under HCW conditions, fish at the highest aluminium concentration ($150 \mu\text{g Al l}^{-1}$) showed progressive increase in Hct-value with increasing exposure duration. Levels were significantly different from controls after 9 and 21 days of exposure. Exposure to $100 \mu\text{g Al l}^{-1}$ also induced increases in Hct-value but significant differences were only observed in 9 day-exposed fish. Levels subsequently declined to approximately control values by 21 days of exposure. Aluminium concentration of $50 \mu\text{g l}^{-1}$ did not exert any measurable influence on blood Hct over the control fish. Control fish under HCW conditions also did not show any noticeable changes with time.

Blood haemoglobin (Hb)

LCW Experiment (Fig. 4.1b): A significant increase in blood Hb concentration was observed in fish at the highest aluminium concentration exposed for 9 days in comparison with control fish, but this thereafter declined to a non-significant level by day 21 of exposure. Although, the fish exposed to $100 \mu\text{g Al l}^{-1}$ showed a considerable increase over control the value on day 21, this was found not be statistically significant. However, fish maintained in water with aluminium concentration of $50 \mu\text{g l}^{-1}$ showed a significant increase over controls by day 21. No noticeable changes were evident in the data for control fish.

HCW Experiment (Fig. 4.1b'): Blood Hb concentration increased progressively with exposure duration in fish exposed to $150 \mu\text{g Al l}^{-1}$, being significantly different from controls on day 9 and day 21 of exposure, a trend consistent with the changes in blood Hct in the same group of fish. Compared with control fish, no marked changes in blood Hb concentrations were observed in any other group of fish and no particular pattern of response was apparent in the results.

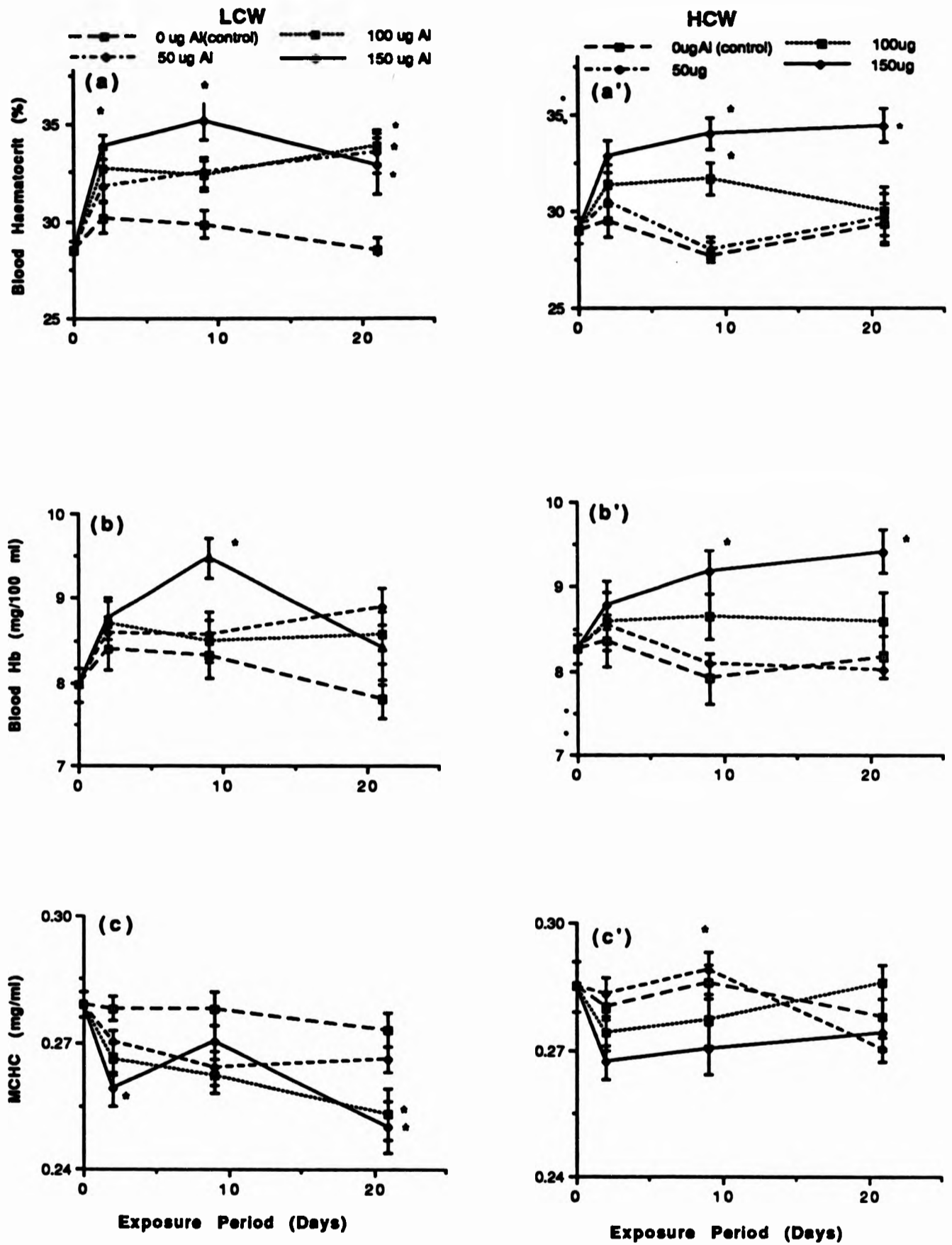

Fig. 4.1.1. Changes in blood haematocrit (a-a') and haemoglobin concentrations (b-b'), and MCHC (c-c') in tilapia during 21 day exposure to different aluminium concentrations at pH 5.2 in LCW and HCW conditions. Vertical bars are \pm S.E. (n=6). Asterisks indicate significant difference from control fish (LSD-test; $P < 0.05$).

Mean cell haemoglobin concentration (MCHC)

LCW Experiment (Fig. 4.1c): In general, MCHC-values decreased as a result of aluminium treatment under all exposure conditions. Fish at 150 $\mu\text{g Al l}^{-1}$ showed a significant decrease in MCHC-value on day 2 but recovered slightly by day 9. However, the MCHC-value again declined to its lowest level in the above group of fish at the termination of the experiment and was found to be statistically significant compared with the control fish. There was a progressive fall in MCHC-value in fish exposed to 100 $\mu\text{g Al l}^{-1}$. Values differed significantly by day 21 of exposure. No trend was evident in the data of control or 50 $\mu\text{g Al l}^{-1}$ treatment groups of fish.

HCW Experiment (Fig. 4.1c'): Exposure to 150 $\mu\text{g Al l}^{-1}$ resulted in a significant reduction in MCHC-value by day 9, although the value returned approximately to control value by day 21 of exposure. No significant difference between means of groups of fish in other aluminium treatments was noted and no trend in the data was evident.

Plasma potassium

LCW Experiment (Fig. 4.2a): There was a tendency for plasma potassium concentrations to be increased by aluminium treatment, particularly at higher concentrations. Significant differences, however, could only be detected in fish held at aluminium concentrations of 150 and 100 $\mu\text{g l}^{-1}$ on day 9. Both the above groups of fish thereafter recorded a slight decrease in plasma potassium levels at the termination of the experiment. There were no noticeable changes in the effect of 50 $\mu\text{g Al l}^{-1}$ in plasma potassium concentrations under LCW conditions.

HCW Experiment (Fig. 4.2a'): There were no significant changes in plasma potassium levels during exposure in HCW conditions, although a considerable increase in plasma potassium was recorded in fish exposed to the highest aluminium

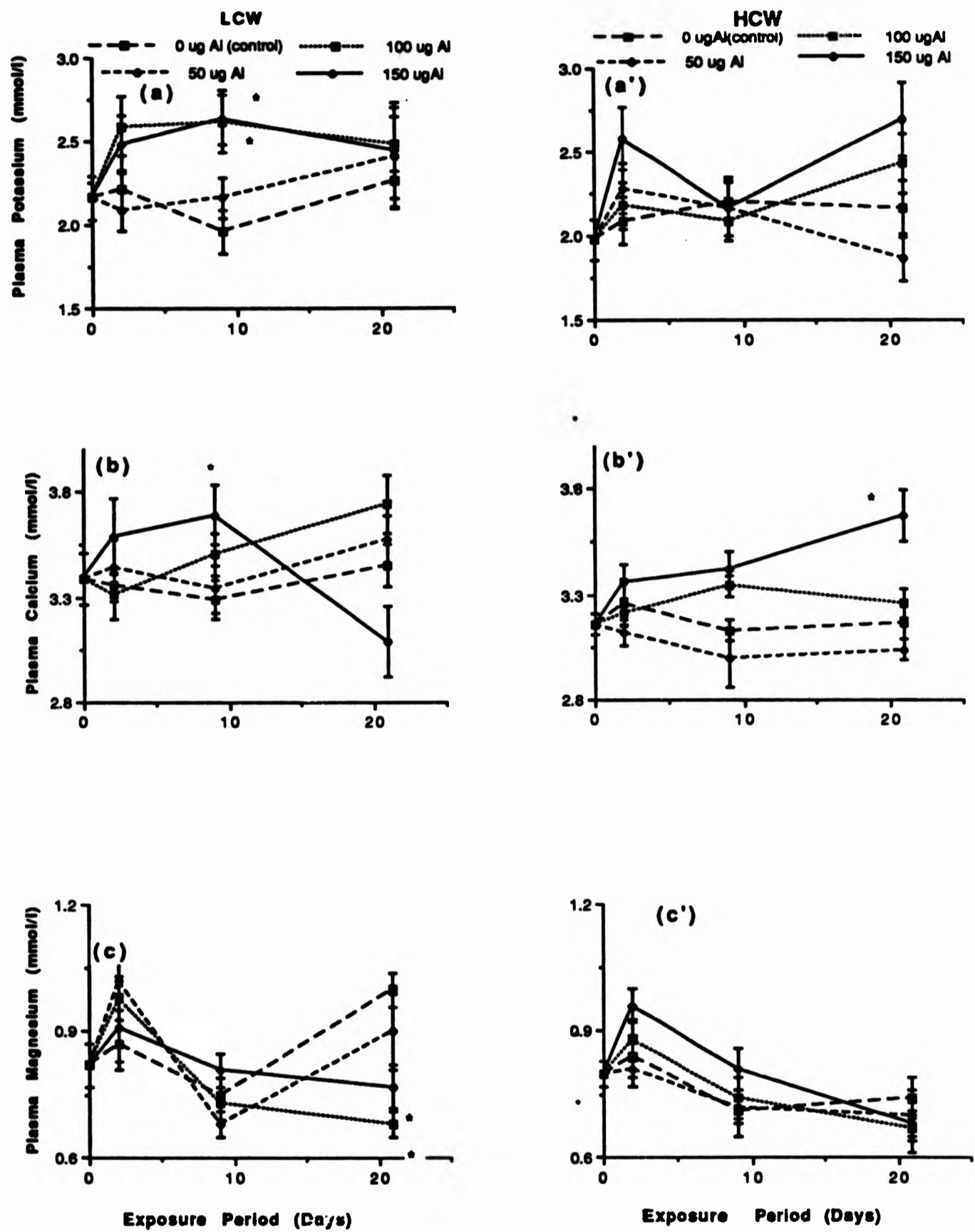

Fig. 4. 3.2. Changes in plasma concentrations of potassium (a-a'), calcium (b-b') and magnesium (c-c') in tilapia during 21 days exposure to different aluminium concentrations at pH 5.2 in LCW and HCW conditions. Vertical bars are \pm S.E. (n=6). Asteriks indicate significant difference from control fish (LSD-test; P,0.05).

concentration ($150 \mu\text{g l}^{-1}$). No trend was apparent in the data.

Plasma calcium

LCW Experiment (Fig. 4.2b): Plasma calcium concentrations significantly increased in $150 \mu\text{g Al l}^{-1}$ -exposed fish in comparison with controls on day 9 of exposure but the level declined to below the control value by day 21. Fish exposed to $100 \mu\text{g l}^{-1}$ aluminium, however, showed an increase (albeit insignificant) in plasma calcium concentration in fish sampled on day 21. There were no noticeable changes among $50 \mu\text{g Al l}^{-1}$ treated fish or among control fish during the experimental period.

HCW Experiment (Fig. 4.2b'): There was a progressive increase in calcium concentration with time in $150 \mu\text{g Al l}^{-1}$ -exposed fish, although significant differences from control fish could only be detected on day 21 of exposure. No other noticeable changes or any particular trend was apparent in the data of other exposure conditions.

Plasma magnesium

LCW Experiment (Fig. 4.2c): Plasma magnesium concentrations tended to decline after an initial (day 2) increase in fish exposed to 150 and $100 \mu\text{g Al l}^{-1}$. However, compared with control fish, significant differences were observed in both groups of fish on day 21. Plasma magnesium was not affected by exposure to $50 \mu\text{g Al l}^{-1}$.

HCW Experiment (Fig. 4.2c'): There was also a tendency for plasma magnesium levels to be reduced in all treatment groups, including control fish, with increasing exposure duration. However, no significant difference could be detected between control and aluminium treated groups of fish.

Plasma sodium

LCW Experiment (Fig. 4.3a): Plasma sodium concentrations declined progressively

with increasing exposure period in fish at $150 \mu\text{g Al l}^{-1}$ and were found to be statistically significant on all sampling dates compared with control fish. Exposure to $100 \mu\text{g Al l}^{-1}$ also resulted in a significant decrease in plasma sodium by day 9 and the level was maintained thereafter as evident from the data of 21 day-exposed fish. No noticeable changes occurred in fish exposed at aluminium concentration $50 \mu\text{g l}^{-1}$ although levels tended to be somewhat higher in control fish throughout the exposure period.

HCW Experiment (Fig. 4.3a'): Under HCW conditions, plasma sodium concentrations were significantly reduced below those of the control in fish exposed to $150 \mu\text{g Al l}^{-1}$ by day 9. However, a partial recovery in plasma sodium subsequently (day 2) occurred in the above group of fish, although levels remained significantly below control values. Aluminium concentrations of 100 and $50 \mu\text{g l}^{-1}$ did not significantly affect plasma sodium levels during the exposure period, although a slight and insignificant decrease was evident on day 9 of exposure in fish exposed to $100 \mu\text{g Al l}^{-1}$.

Plasma osmolality

LCW Experiment (Fig. 4.3b): Consistent with the plasma sodium data, there was also a progressive decline in plasma osmolality with time in $150 \mu\text{g Al l}^{-1}$ -exposed fish, being significantly different from the control at day 9 and day 21 of exposure. Fish exposed to $100 \mu\text{g Al l}^{-1}$ also showed a significant reduction in plasma osmolality on day 9 and thereafter increased slightly by day 21 but still remained significantly below control values. There were slight tendencies for plasma osmolality to increase with exposure duration in both $50 \mu\text{g Al l}^{-1}$ fish and control fish.

HCW Experiment (Fig. 4.3b): Plasma osmolality in fish exposed to $150 \mu\text{g Al l}^{-1}$ was significantly reduced from controls by day 9 of exposure. However, levels thereafter

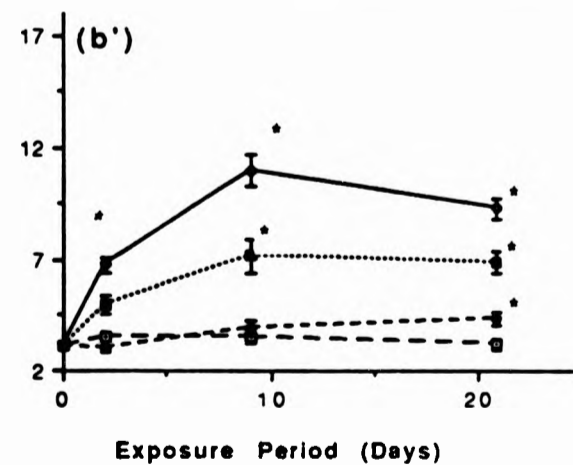
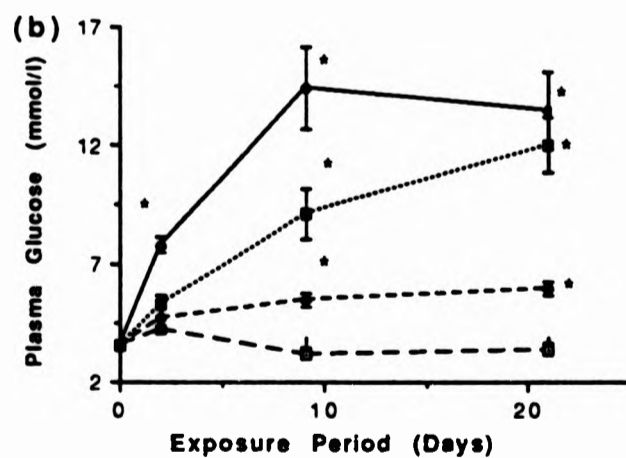
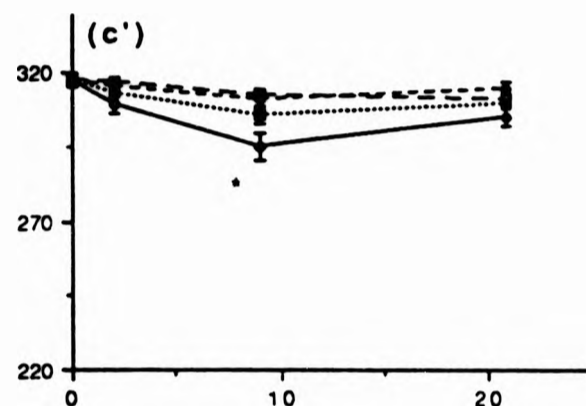
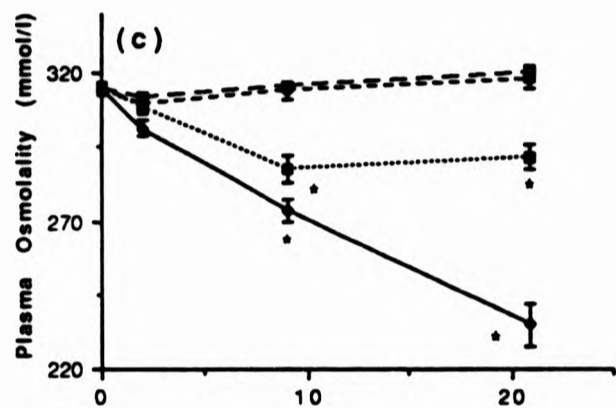
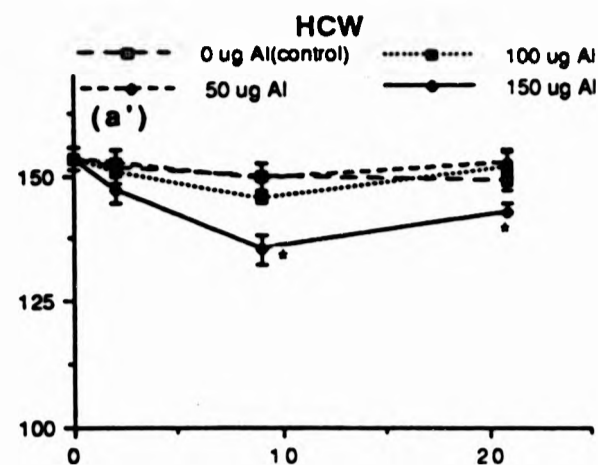
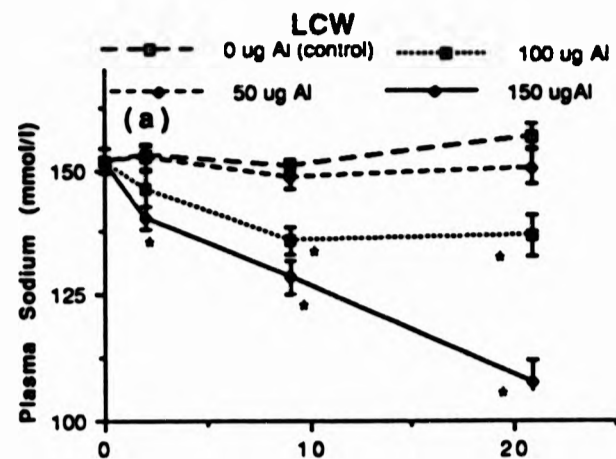

Fig.4.3. Changes in plasma sodium (a-a') and glucose (b-b') concentrations, and plasma osmolality (c-c') in tilapia during 21 days exposure to different aluminium concentrations at pH 5.2 in LCW and HCW conditions. Vertical bars are \pm S.E. (n=6). Asteriks indicate significant differences from control fish (LSD-test; $P < 0.05$).

increased considerably and by the termination of the experiment they were no longer significantly different from those of the control fish. Under LCW conditions, however, plasma osmotic value was not significantly affected by 100 and 50 $\mu\text{g Al l}^{-1}$ treatments, although a considerable but statistically insignificant decrease was noted on day 9 in fish exposed to 100 $\mu\text{g Al l}^{-1}$. Unlike the LCW control fish, plasma osmolality in control fish in LCW experiment declined slightly with time.

Plasma glucose

LCW Experiment (Fig.4.3c): Plasma glucose concentrations increased in all aluminium treatment groups of fish. Fish exposed to 150 $\mu\text{g Al l}^{-1}$ showed a maximum response in plasma glucose levels on day 9 and thereafter declined slightly by day 21 of exposure. However, compared with control fish, the levels remained significantly higher throughout the trial. Fish exposed to 100 $\mu\text{g Al l}^{-1}$ showed a progressive increase in glucose level and were also found to be significantly different from the controls on all sampling dates. Although they increased progressively, plasma glucose levels in fish exposed to 50 $\mu\text{g Al l}^{-1}$ were found to be significantly different from control values only on days 9 and 21 of exposure. Control fish showed a slight decrease in plasma glucose concentrations with time.

HCW Experiment (Fig.4.3.3c'): Plasma glucose concentrations were also raised by aluminium treatments under HCW conditions. Compared with controls, fish exposed to 150 and 100 $\mu\text{g Al l}^{-1}$ had significantly elevated levels of plasma glucose throughout the experimental period, although levels declined slightly by day 21 in the former group of fish. Fish at 50 $\mu\text{g Al l}^{-1}$, however, differed significantly in their plasma glucose concentrations from those of control fish only on day 21 of exposure. In control fish the level declined slightly with time.

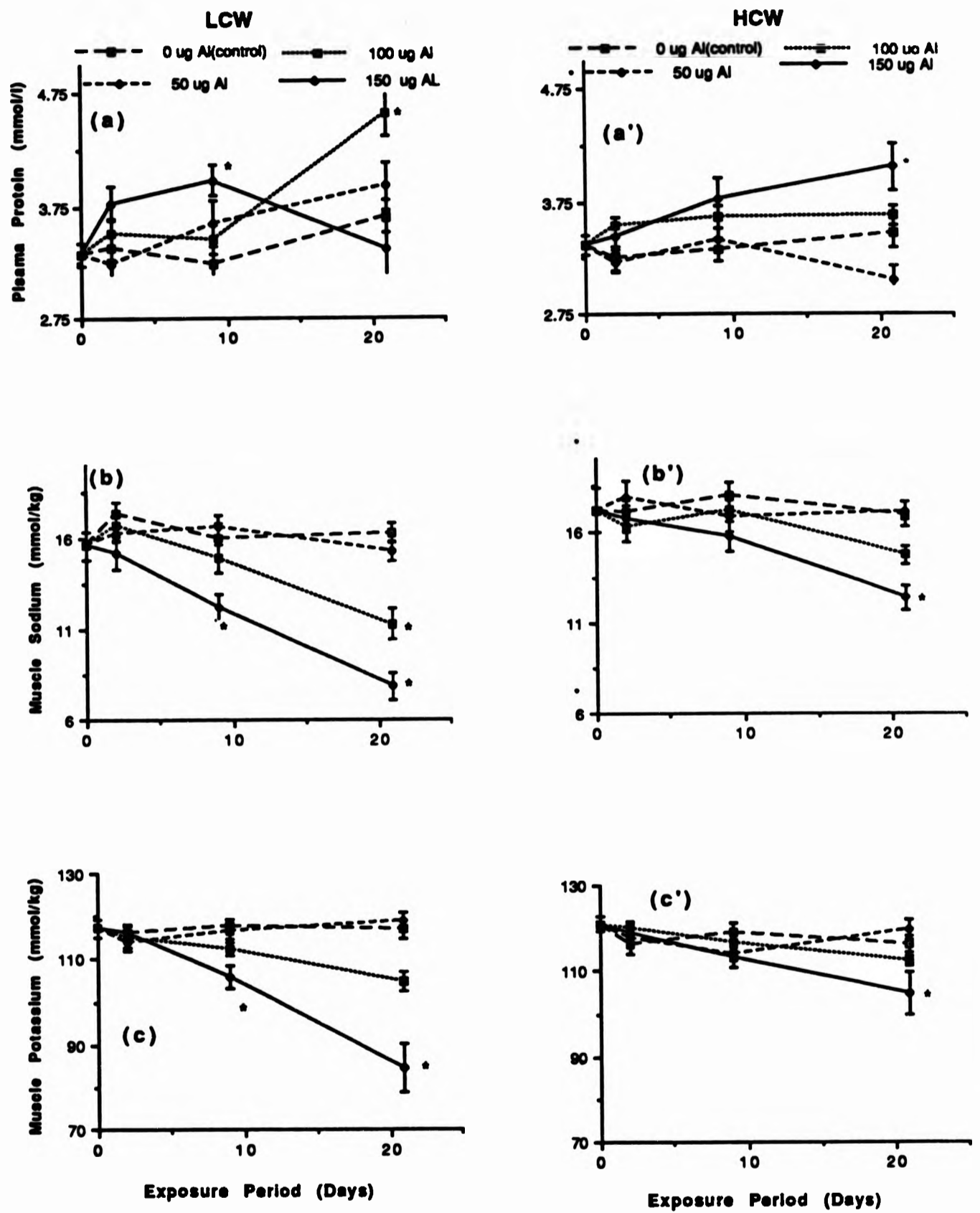

Fig.4. .4. Changes in plasma total protein (a-a'), and muscle sodium (b-b') and potassium (c-c') concentrations in tilapia during 21 days exposure to different aluminium concentrations at pH 5.2 in LCW and HCW conditions. Vertical bars are \pm S.E. (n=6). Asteriks indicate significant difference from control fish (LSD-test; $P < 0.05$).

Total plasma protein

LCW Experiment (Fig. 4.4a): Plasma protein concentrations increased slightly, but significantly, at aluminium concentrations of $150 \mu\text{g l}^{-1}$ on day 9 of exposure. Thereafter, the level declined to below that of the control fish by the termination of the experiment and was not found to be statistically significantly different from control fish. A trend was observed which was similar to that noted for blood Hct and blood Hb concentrations in 21 day- exposed fish under LCW conditions. Fish exposed to $100 \mu\text{g Al l}^{-1}$ did not show any noticeable changes in plasma protein concentrations during the initial period of exposure (≤ 9 days of exposure). However, plasma concentrations among this group increased significantly by the end of the experimental period.

HCW Experiment (Fig. 4.2a'): Plasma protein concentrations tended to be elevated among fish at aluminium concentrations $150 \mu\text{g Al l}^{-1}$ with exposure time. However, when compared with control fish significant differences were recorded only in fish exposed for 21 days. No noticeable changes or trends in plasma protein concentrations were apparent among other treatment groups of fish.

4.3.3. Muscle Tissue Parameters

Muscle sodium

LCW Experiment (Fig. 4.4b): Fish exposed to $150 \mu\text{g Al l}^{-1}$ showed a gradual decline in muscle tissue sodium concentrations with exposure time and compared with control fish, statistically significant differences were noted on day 9 and 21 of exposure. A similar difference in tissue sodium level was also observed among fish held at $100 \mu\text{g Al l}^{-1}$ for 21 days. Neither the $50 \mu\text{g Al l}^{-1}$ -exposed fish nor the control fish showed any changes in muscle tissue sodium concentrations with time.

HCW Experiment (Fig. 4.4b'): A significant reduction in muscle tissue sodium level was observed in fish exposed to $150 \mu\text{g Al l}^{-1}$ only on day 21 of exposure. No other

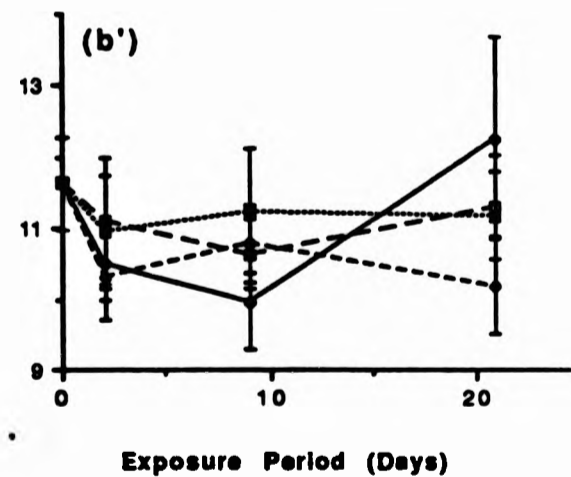
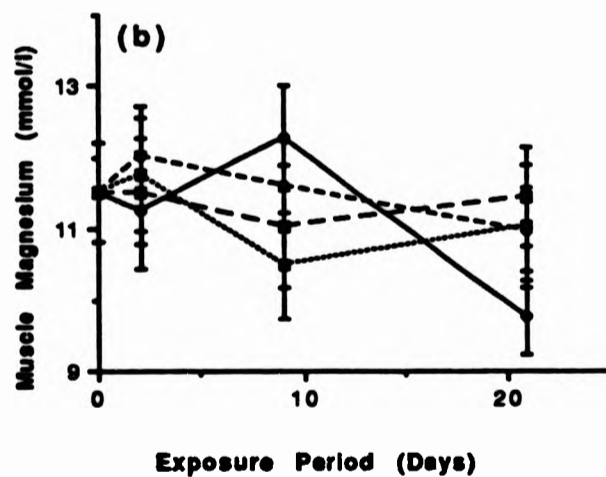
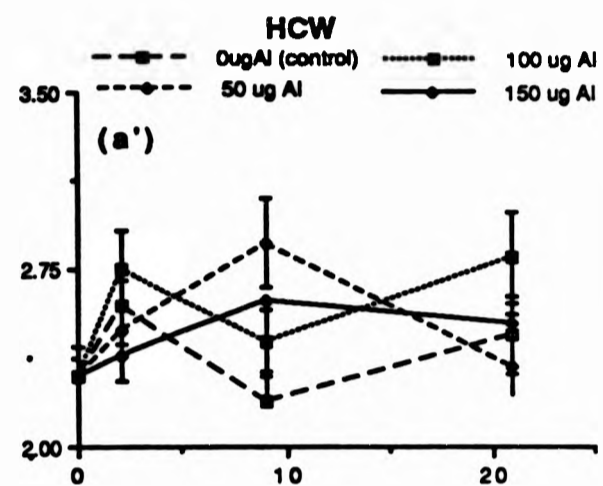
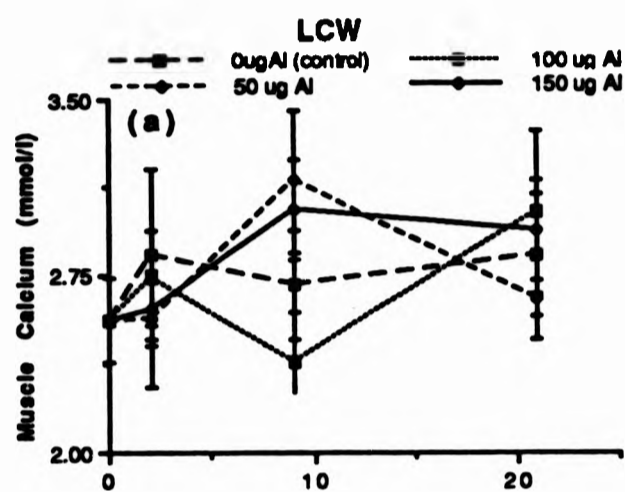

Fig.4...5. Changes in muscle tissue calcium (a-a') and magnesium (b-b') concentrations in tilapia during 21 days exposure to different aluminium concentrations at pH 5.2. in LCW and HCW conditions. Vertical bars are \pm S.E. (n=6). Asteriks indicate significant difference from control fish (LSD-test; $P < 0.05$).

aluminium treatment induced noticeable changes in tissue sodium concentrations in fish during the experimental period and no trend was evident in the results.

Muscle potassium

LCW Experiment (Fig. 4.4c): Muscle potassium concentrations also declined progressively with exposure time in fish exposed to $150 \mu\text{g Al l}^{-1}$ and were significantly different from control values on days 9 and 21 of exposure. Fish held at aluminium concentration of $100 \mu\text{g l}^{-1}$ also lost a large proportion of tissue potassium by the termination of the experiment, although due to large variations in the data, the decrease was not statistically significant. There were no noticeable changes in muscle potassium concentrations in $50 \mu\text{g Al l}^{-1}$ -exposed or in control fish.

HCW Experiment (Fig. 4.4c'): As with muscle sodium data under HCW experiment, a similar trend in the changes of muscle potassium concentrations was also evident. Thus, compared with control fish, a significant reduction was observed in fish exposed to $150 \mu\text{g Al l}^{-1}$ after only 21 days of exposure. There were no noticeable changes in muscle potassium concentrations in any other aluminium treatment or among control fish.

Muscle calcium

The calcium concentrations in muscle tissue during both LCW (Fig. 4.5a) HCW (Fig. 4.5a') experiments remained unaffected by any treatment conditions and no particular trend emerged from the results of the present study.

Muscle magnesium

During experiments with LCW, fish exposed to $150 \mu\text{g AL l}^{-1}$ showed a slight decrease in muscle tissue magnesium concentrations on day 21 of exposure but this was found to be statistically insignificant (Fig.4.5b). Similarly, fish held under HCW conditions

were also unaffected by any treatment conditions (Fig. 4.5b').

4.3.4. Aluminium Content in Gill Tissue

The results from measurements of aluminium accumulation in gills during both the LCW and HCW experiments in the present study are presented in Table-4.3.2. Tissue analyses showed increasing levels of aluminium in/or on the gills with increasing concentrations of aluminium in the exposure media. In general, aluminium accumulation occurred mostly during the initial period of exposure (day 2) and thereafter there was little changes in gill aluminium content. The slight decrease in aluminium content noted in gills of the fish exposed to $150 \mu\text{g Al l}^{-1}$ on day of 21 of LCW exposure is probably attributable to mucus sloughing and consequent loss of aluminium complexed or associated with mucus. Visual inspection of the data revealed no marked differences in gill aluminium content between LCW and HCW fish. Accumulation of aluminium in gills and its significance, in general, is discussed in Chapter 3.

Table-4.3. Gill aluminium content ($\mu\text{g/g}$ dry tissue) in tilapia exposed to different aluminium concentrations at during chronic (21 d) exposure experiments in LCW and HCW conditions. Data are represented as means \pm S.D. (n = 5-6).

Nominal Al conc. ($\mu\text{g/l}$)	LCW Experiment			HCW Experiment		
	2	9	21	2	9	21
150	226 \pm 43	318 \pm 57	286 \pm 49	218 \pm 47	294 \pm 50	309 \pm 89
100	157 \pm 32	247 \pm 31	261 \pm 36	179 \pm 42	215 \pm 37	198 \pm 48
50	58 \pm 14	95 \pm 28	119 \pm 30	78 \pm 16	89 \pm 29	106 \pm 23
0	8 \pm 6	10 \pm 6	6 \pm 5	5 \pm 3	9 \pm 5	8 \pm 7

4.4. DISCUSSION

Many environmental stresses are chronic rather than acute in nature and therefore, studies aimed at examining the dynamics of various physiological parameters over a long-term are necessary to enable elucidation of the mechanisms of recovery and/or acclimation. Acid/aluminium-induced changes in various physiological parameters observed during the short-term exposures were again apparent in qualitative terms in the present experimental trial. The manifestation of acid/aluminium-induced changes in blood and tissue parameters has been discussed in the preceding chapter (Chapter 3) and those will not be repeated here. Therefore, the present discussion mainly concentrates on the chronic effects observed in the present study and their interpretation in relation to fish health and survival.

It is evident from the results of the present study that the effects of acid/aluminium exposure were variously modified (both qualitatively and quantitatively) by exposure duration. However, the nature and degree of such effects were clearly dependent on the aluminium and calcium concentrations of the exposure media.

The physiological conditions of the fish at the highest aluminium concentration (150 $\mu\text{g l}^{-1}$) under LCW conditions gradually deteriorated with exposure duration and, in fact, this group of fish appeared to be severely stressed towards the end of the experiment. In iono-osmoregulatory terms, the fish did not show any sign of recovery. However, certain other blood parameters such as Hct, Hb and plasma total protein and potassium concentrations declined markedly by the end of the experiment from day 9 values, although these parameters are known to be increased with increasing level of stress in fish (see Chapter 3). While there were no noticeable changes in other blood parameters, Wood *et al.* (1988b) also reported a similar decrease in Hct-value below the controls

in brook trout, *S. fontinalis*, exposed to $150 \mu\text{g Al l}^{-1}$ for 10 week. The reasons for such decreases are not clear and the authors offered no explanation. However, in the absence of any RBC swelling (as evidenced by MCHC-value) in the present study, the observed decreases in Hct-values might have resulted either from the destruction of RBC or from plasma dilution or a combination of both. Concomitant decreases in plasma total protein and potassium concentrations are indicative of haemodilution. Indeed, the sampled blood from this group of fish appeared to be more dilute than that of the corresponding control fish. The occurrence of haemodilution following exposure to other metals has previously been reported by Dick and Dixon (1985) and Tort and Torres (1988) in rainbow trout, *S. gairdneri*, and dogfish, *Schyliorhinus canicula*, respectively. The claim made here for the possible occurrence of haemodilution is not conclusive and the measurement of plasma volume in stressed fish would be required to establish this.

The corresponding group of fish (fish at $150 \mu\text{g Al l}^{-1}$) under HCW conditions, however, showed partial recovery in plasma sodium and plasma osmolality on day 21 of exposure, although concomitant muscle tissue analyses revealed a decrease in sodium and potassium ion concentrations during the same exposure period. The interpretation of this would be that the partial recovery in plasma sodium and an increase in plasma potassium concentrations observed in the present study were probably achieved at the expense of tissue ion levels. The basis for such tissue ion re-absorption has been discussed in detail in the preceding Chapter (Chapter 3). Booth *et al.* (1988) also reported a partial recovery in plasma ion levels in brook trout, *Salvelinus fontinalis*, exposed to $111 \mu\text{g Al l}^{-1}$ at pH 5.2 for 11 days. Tissue ion concentrations, however, were not measured in that study. If the observed situation is sustained over time, tissue ion reserves may eventually be exhausted leading to death of the fish. Alternatively, the fish may modulate its branchial ionoregulatory mechanisms in order to survive, in

which case the fish may recover completely or a new steady state in plasma and tissue ion concentrations may be established. However, a more prolonged exposure experiment would be necessary to elucidate this.

The aluminium concentration of $100 \mu\text{g l}^{-1}$ also adversely affected the fish under LCW conditions. Although the majority of the blood parameters showed slight signs of recovery after 9 days of exposure, tissue sodium and potassium concentrations continued to decline suggesting that this group of fish, in fact, was still in negative ion balance. As suggested above, such a condition might affect survival of fish with more prolonged exposure unless the fish modulate their ionoregulatory mechanisms. In an ionoregulatory sense, the corresponding group of fish under HCW were not affected during the present experimental period. However, this group of fish showed gradual and significant increases in blood haematocrit and plasma glucose concentrations. Similar changes in Hct and glucose concentration were also observed in fish exposed to aluminium concentration of $50 \mu\text{g l}^{-1}$ under LCW conditions, while there were no remarkable changes in other blood or tissue parameters, particularly ionic concentrations. The increases in Hct-value could be due to respiratory adjustment by the fish in the face of increases in blood-gas-diffusion distance as observed in histological preparations of gills from the same groups of fish (see Chapter 7). The chronic increases in plasma glucose levels in the above groups of fish in the absence of ion balance agrees with Wood *et al.* (1988b) who also found a significant increase in plasma glucose level in chronically-exposed brook trout during sublethal acid/aluminium exposure, although there were no changes in ionic fluxes. This may be interpreted as an adaptive response by the fish. Concomitant increases in plasma cortisol recorded by Wood *et al.* (*ibid*) support this view. Whatever the reasons for the increase in plasma glucose concentrations, the production of glucose and associated changes in the physiology of fish certainly involve an energetic cost which may affect fish growth and reproduction.

Absence of any changes in blood parameters in fish exposed to $50 \mu\text{g Al l}^{-1}$ under HCW conditions indicate that this level of aluminium is physiologically safe for tilapia, of course, with respect to the time period considered in these experiments.

The apparent lack of any noticeable changes in muscle calcium and magnesium concentrations is of particular interest. Experiments with acid only exposure also yielded a similar pattern of results (Giles *et al.*, 1984; Audet *et al.*, 1988). However, there are suggestions that probably bone calcium is re-absorbed during such exposure. Chapter 6 investigates this aspect.

It is apparent from the results of the present study that higher external calcium concentrations lessened (in the case of highest aluminium concentrations) or abolished (in the case of lower aluminium concentrations) the adverse effects of aluminium exposure. In other words, higher aluminium concentrations were required under HCW conditions to elicit a similar observed effect in LCW fish. The physiological basis of the protective action of external calcium concentrations are discussed in detail in Chapter 3 & 8

In summary, the general conclusion of the present study is that depending on exposure, aluminium and calcium concentrations, and exposure duration, fish may or may not be physiologically affected in a deleterious manner by chronic acid/aluminium exposure. The overall adverse effects in internal physiological status of tilapia (and, in particular, ionic balance) were observed in fish exposed to $\geq 100 \mu\text{g}$ and $\geq 150 \mu\text{g Al l}^{-1}$ under LCW and HCW conditions, respectively. Although the lower aluminium concentrations did not induce any imbalance in internal ionic concentrations, maintenance of elevated plasma glucose levels in fish during long-term exposure could be important to growth and reproduction.

CHAPTER 5

**EFFECTS OF ACID/ALUMINIUM EXPOSURE ON THE GILL Na⁺/K⁺-ATPase
AND Ca²⁺-ATPase ACTIVITY OF TILAPIA, *OREOCHROMIS NILOTICUS*.**

5.1. INTRODUCTION

Lethal and sublethal concentrations of aluminium in the acidic environment have been shown to cause deviations from normal values of major plasma ions in a variety of teleosts (see Chapter 1 and 3). Considering the gills as the target organ of aluminium toxicity, it has been suggested that such an effect might have caused by the action of aluminium ions on the branchial mechanism of ionoregulation (reviews: Wood and McDonald, 1987; McDonald *et al.*, 1989; Potts and McWilliams, 1989 and see also Booth *et al.*, 1988; Wood *et al.*, 1988b).

Aluminium-induced changes in the ionoregulatory function may be caused by an effect on active transport or on the passive movement of ions or a combination of both. Accordingly, a number of studies have reported anomalies in flux rates of sodium ions (Dalziel *et al.*, 1986; 1987; McDonald and Milligan, 1988; Booth *et al.*, 1988). The above studies convincingly demonstrated that both components of ion flux (influx and efflux) were affected during exposure to acid/aluminium conditions. It is well known that freshwater teleosts continually take up ions from strongly hypotonic environments in order to compensate for the diffusional loss. However, active uptake of ions is an enzyme-mediated, energy-requiring process. Therefore, any changes in influx (uptake) could be expected to be reflected in branchial ion transport enzyme activity.

The significance of branchial adenosine triphosphatase enzymes (ATPases) in controlling high energy metabolic transformation and ion transport across the gill epithelium is well known and the subject has been duly reviewed (Evans, 1980; 1982; DeRenzis and Bornancin, 1984). A number of ATPases have been identified and described in teleost gills and by now, it is fairly well established that Na^+/K^+ and Ca^{2+} -ATPases are actively involved in the transport of sodium and calcium to the body across the gill membranes

(Chapter 1).

Many studies, both *in vivo* and *in vitro*, have reported the effects of metal ions (including beryllium, chromium, copper, cadmium, iron, mercury, lead, manganese, silver, vanadium, zinc etc.) on ATPases in teleost gills (Kuhnert and Kuhnert, 1976; Bouguegneau, 1977; Riedel and Christensen, 1979; Watson and Beamish, 1980, 1981; Stagg and Shuttleworth, 1982; Bansal *et al.*, 1985). It has been suggested that metals can bind to an enzyme system in a number of different ways depending upon the molecular structure and the availability of functional groups. Binding of metal at active sites or remote locations on the enzyme molecules may result in changes in enzyme activity (Jackim, 1974).

Aluminium is known to bind with enzyme-cofactors and a variety of protein molecules in biological systems (Trapp, 1986) and several studies have demonstrated its inhibitory effects on a number of enzymes, including Mg²⁺-ATPase (Sigel and Haug, 1982; 1983a; Farnell *et al.*, 1985 and see also Trapp, 1986, for a review). The ability of aluminium to interfere with Na⁺/K⁺-ATPase has been demonstrated in *in vitro* studies (Riedel and Christensen, 1979), although it was not completely clear which source of enzyme or exactly which enzyme assay procedure was used. In plant cells, aluminium inhibits calcium transport at least in part through the inhibition of Ca²⁺/Mg²⁺-ATPase transport system (Sigel and Haug, 1983b). Therefore, it would not be altogether unexpected to find such an effect in fish enzyme systems.

A close scrutiny of the available literature indicates that, in general, *in vitro* exposure to metal causes a decrease in ATPase activity although the results from *in vivo* exposures are not always so clear, and possibly relate to homeostatic mechanisms causing compensatory changes in the amount or turnover rate of enzyme in addition to

the direct toxic effect of the metals (compare Watson and Beamish, 1980 and Watson and Beamish, 1981; see also Stagg and Shuttleworth, 1982a). Since aluminium is known to accumulate in/on gills (Neville, 1985; Witters *et al.*, 1987; Playle *et al.*, 1989 and this study) and to traverse gill epithelium (Karlsson-Norrgren *et al.*, 1986; Youson and Neville, 1987), an interaction between aluminium and transport enzymes at the gills could be expected.

In an attempt to investigate the possible effect of aluminium on branchial ionoregulation, Staurnes *et al.* (1984a) studied the effect of aluminium on Na⁺/K⁺-ATPase activity in rainbow trout, *Salmo gairdneri*, and reported a significant reduction in enzyme activity. However, the results were to some extent confounded by the use of tap water of unspecified composition since the toxicity of aluminium is greatly influenced by ambient water composition. To date no attempt has been made to investigate this aspect under controlled water quality conditions.

Ambient calcium concentrations have been shown to mitigate ionoregulatory disruption in fish, mainly through its effects on the branchial mechanism of ionic regulation (see Chapter 1 & 3). It would, therefore, be interesting to investigate whether such effects are linked with branchial ATPase activity. Similarly, a time-course investigation over a prolonged exposure period might provide information on the adaptative ability of fish through its modulatory effects on transport enzyme system during acid/aluminium exposure.

In the present study two important ion transport enzymes; namely, Na⁺/K⁺- and Ca²⁺-ATPase, have been selected for investigation. A series of experiments is described in which tilapia were exposed to different aluminium and calcium concentrations for varying periods of experimental duration (a) to ascertain whether aluminium under *in*

vivo and *in vitro* exposure conditions affects ATPase activity, (b) to indicate whether ambient calcium concentration exerts its ameliorating effects on aluminium-induced changes in ATPase enzymes, and (c) to ascertain whether or not the effects of aluminium vary with the length of exposure.

5.2. MATERIALS AND METHODS

The source of experimental fish, *O. niloticus*, and the procedure for maintenance of fish stock were as described in Chapter 2. Pre-exposure acclimation and flow-through exposure schedules followed were also identical to those described earlier (Chapter 2).

5.2.1. Experimental Protocol

Four experiments were conducted in an attempt to investigate the effects of acid and acid/aluminium exposures on ATPase activity in the tilapia gill under *in vivo* exposure conditions. In addition, studies were also carried out to demonstrate the *in vitro* effects of aluminium on ATPase enzyme activity.

5.2.1.1. Experiment 1. Exposure to Acid Conditions

This experiment was designed to assess the short-term effects of acid on gill ATPase activity. Fish (mean weight 63.56 ± 4.17 g) were exposed to pH 6.8 and 5.2 for 4 days both in LCW (0.6 mg Ca l^{-1}) and HCW (16 mg Ca l^{-1}) conditions. Six fish were tested in each treatment condition. The fish were sacrificed at the termination of the experiment on day 4 of exposure and gill samples were taken for ATPase analysis. Pre-exposure acclimation and subsequent exposure schedules were as described in Chapter 2.

5.2.1.2. Experiment 2. Short-term Exposure to Acid/Aluminium Conditions

The aim of this experiment was to delineate the short-term effects of acid/aluminium exposure on gill ATPase activity under conditions of considerable aluminium-induced stress. Fish were tested at aluminium concentrations of $300 \mu\text{g l}^{-1}$ and $0 \mu\text{g l}^{-1}$ (control) both in LCW and HCW conditions. A group of four fish was introduced into each of the duplicate experimental tanks of each aluminium treatment group. The mean weight

of fish was 64.19 ± 2.75 g. Pre-exposure acclimation and subsequent exposure schedules followed were as described in Chapter 2. The fish were sacrificed after four days of exposure. Gill samples from each fish were collected for analysis of ATPase activity and gill aluminium levels.

5.2.1.3. Experiment Series 3. Chronic Exposures to Acid/Aluminium Conditions

These experiments investigated the chronic effects of acid/aluminium exposure on gill ATPase activity and were designed to be directly comparable to the chronic acid/aluminium experiments investigating the effects of acid/aluminium exposures on blood parameters (Chapter 4) in an attempt to relate measurements of gill ATPase activity to plasma electrolyte data. Therefore, the experimental protocol followed was identical. In brief, in separate trials, two experiments were conducted; one in LCW and one in HCW conditions. Each trial lasted for 21 days. Fish were tested at aluminium concentrations of 0, 50, 100 and 150 $\mu\text{g l}^{-1}$ at pH 5.2. The mean weights of fish for LCW and HCW experiments were 62.36 ± 2.78 and 71.42 ± 3.02 g, respectively. Ten fish were introduced into each tank. Experimental tanks were duplicated for each of the treatment groups. Three fish/tank were sacrificed on day 2, 9 and 21 of exposure. An initial sample (one fish/tank; thus making a pooled sample of eight fish) was also taken under acclimation conditions. Gill samples were taken from each fish for analysis of ATPase activity and gill aluminium content.

5.2.2. Preparation of Gill Homogenate for Enzyme Assay

Fish were netted individually and quickly decapitated to allow each fish to bleed. The 2nd and 3rd gill arches from the right-hand side of each fish were removed and briefly perfused through afferent vessel with heparinized saline (50 i.u. heparin ml^{-1} in 0.85% sodium chloride), followed by ice-cold homogenizing medium, with the help of a syringe. The homogenizing medium contained 0.25 M sucrose (Sigma), 20 mM

imidazole (pH 7.2) and 5 mM EDTA (disodium-salt, Sigma). Each gill arch was then rinsed in homogenizing medium and blotted dry. The gill filaments were then quickly excised from the gill arch and placed in pre-weighed polyethylene vials (kept on ice) containing 5 ml of the homogenizing medium. After sampling, each vial was then re-weighed to determine gill tissue weight. The gill filaments were initially homogenized in a tissue homogenizer (Ultrataurrax) for 40 s and 5 ml distilled water was added to each vial. The tissue homogenates were further disrupted ultrasonically (see Madsen and Naamasen, 1989) in an ultrasonicator for 30 s (amplitude 20 μ M at medium speed).

The homogenates were filtered through double layered gauze. The gauze was washed with a few ml of distilled water which was added to the homogenate. The resulting homogenate was then diluted to a tissue concentration of 25 mg ml⁻¹. The whole procedure was performed cooling on ice. A little 2-methylmercaptoethanol (Sigma) was added to each vial to give a concentration of 2 mM ml⁻¹ homogenate (see Johnson et. al, 1977; Madsen and Naamasen, 1989), in order to prevent any loss of enzyme activity upon storage. Aliquots of 1 ml homogenate were taken in small vials for analysis of Na⁺/K⁺, and Ca²⁺-ATPase activity. The vials were then quickly dipped into liquid nitrogen and stored at -70°C for 2-3 days during which time analysis of samples was carried out.

Prior to enzyme analysis, frozen samples were quickly thawed and were further diluted by adding 1 ml distilled water to give a final concentration of approximately 12.5 mg tissue ml⁻¹ homogenate. The homogenates were stirred vigorously before analysis.

5.2.3. Enzyme Assay

The above homogenates were incubated in different appropriate incubation media for the hydrolysis of ATP. The ATPase activity was measured by the determination of the

amount of inorganic phosphate (Pi) liberated from the hydrolysis of substrate ATP during incubation with gill homogenate (enzyme suspension).

Incubation

Na⁺-K⁺-ATPase: Aliquots of 100 μ l homogenate (75-150 μ g protein) were added to two incubation media which differed in the presence and absence of potassium and ouabain: incubation medium A (100 mM NaCl, 20 mM KCl, 6 mM MgCl₂, 20mM imidazole, pH 7.4) and medium B (100 mM NaCl, 6 mM MgCl₂, 20 mM imidazole, pH 7.4 and 0.5 mM ouabain (Strophanthin-G; Sigma)) (see review by DeRenzis and Bornancin, 1984 and see also Balm *et al.*, 1988, for incubation media composition). The optimum level of ionic, ATP and ouabain concentrations were checked by preliminary trials and found to compare favourably with the above authors and were therefore adopted for the present analysis. Both the media were prewarmed at 37°C for 10 minutes before adding the homogenate. The reaction was initiated by the addition of 100 μ l vanadium-free ATP (disodium salt, Sigma) to give a final ATP concentration of 2mM in the reaction medium. Solutions of ATP were used within 4 h of their preparation. The final volume of the reaction media was 2 ml in each reaction tube. The reaction was carried out in a thermostatically controlled water bath at 37°C (e.g. the optimum temperature for ATPase system; see McCarty and Houston, 1977; Watson and Beamish, 1980) with occasional shaking. After 20 min the reaction was stopped by adding 2 ml ice-cold 10% TCA, while immersing the tubes in an ice bath. The reaction was linear over the duration of incubation. After 10 min the tubes were centrifuged at 12000 x g in a refrigerated centrifuge (MSE, High Speed) for 7 min in order to ensure the total precipitation of protein.

A 1 ml sample of supernatant was taken from each tube for determination of inorganic phosphate (Pi) liberated during incubation of the enzyme (see below for Pi estimation).

The difference in the amount of Pi liberated between medium A (K⁺ present) and medium B (K⁺ absent, ouabain present) was used to calculate Na⁺/K⁺-ATPase (ouabain-sensitive ATPase) activity.

Ca²⁺-ATPase: Ca²⁺-dependent ATPase activity was determined as the difference between the rate of Pi liberated in the presence and absence of calcium in the incubation media. Aliquots of 50 µl thawed homogenate (50-75 µg protein) were added to an incubation medium containing 3 mM CaCl₂ and 30 mM imidazole buffer (pH 7.8) and also to an incubation medium containing only 30 mM imidazole (pH 7.8) (see Bansal *et al.* 1985). To initiate the reaction 100 µl ATP (disodium salt, Sigma) was added to each reaction tube to give a final concentration of 3mM ATP in the reaction medium. The total volume of the reaction medium in each tube was 2 ml. The reaction was run for 20 min at 37°C in a water bath with occasional shaking and the termination of the reaction and subsequent centrifugation of the reaction mixture were carried out as described above. A 1 ml sample of supernatant was taken from each reaction tube for the determination of Pi liberated during incubation. Incubations were carried out in duplicate for each sample and the mean was used to calculate ATPase activity.

Determination of Inorganic Phosphate (Pi):

Inorganic phosphate (Pi) liberated from the hydrolysis of ATP in the reaction media was determined colorimetrically following the method of LeBel *et al.* (1978). This is a modification of the original Fiske-Subbarow method (Fiske and Subbarow, 1925) and claims to be superior with respect to sensitivity and colour stability. This method is also free from interferences with EDTA, sucrose and other commonly used chemicals in enzyme assay.

In brief, 1 ml of the supernatant, 3 ml reagent A (0.25% copper sulphate pentahydrate

and 4.6% sodium acetate trihydrate in 2N acetic acid) and 0.5 ml reagent B (5% ammonium molybdate) are mixed with a vortex mixer. Then 0.5 ml reagent C (Elon 2%: in 5% sodium sulfite) was added and mixed. Fifteen min later, the absorbance was read at 870 nm using a Kontron Spectrophotometer. Standard phosphate solutions were prepared by diluting a stock solution of KH_2PO_4 (1 mg ml^{-1}). The specific activity of the enzymes was then calculated after the estimation of the protein content in the enzyme suspension.

Estimation of Protein:

The protein content in each homogenate was determined according to the method of Lowry *et al.*, 1951. Estimation was carried out on 100 or 50 μl sample aliquot depending on the amount of homogenate used for Na^+/K^+ and Ca^{2+} -ATPase assay, respectively. Crystalline bovine serum albumin was used as reference standard.

The specific activity of the enzymes is reported as $\mu\text{M Pi protein mg}^{-1} \text{ h}^{-1}$.

5.2.4. In vitro Experiment

For *in vitro* studies, the gill samples were obtained from the stock fish (see Chapter 2). Gill tissue homogenate (enzyme suspension) was prepared as outlined above (Section 5.2.3). Then aluminium ($\text{Al}_2(\text{NO}_3)_6 \cdot 9\text{H}_2\text{O}$) was added to the reaction media containing enzyme suspension and pre-warmed for 10 min prior to incubation. Subsequent incubation and other necessary procedures for the enzyme assay were essentially the same as described above (Section 5.2.4), except that 50 mM imidazole (buffer) was used in the reaction media in the present case. The aluminium concentrations tested were 0, 200, 400, 800, 1600 and 3000 $\mu\text{g Al l}^{-1}$ (0, 7.40, 14.80, 29.60, 59.25 and 111.1 mmol l^{-1}). Individual stock solutions were prepared for each of the concentrations used and 100 μl aluminium solution was added to each incubation tube.

5.2.5. Statistical Analysis

Before performing any statistical analysis normality of the data and homogeneity of variances were checked as described earlier (Chapter 3). Appropriate transformations (logarithm or square root) of the data were performed, where necessary, to obtain normality and homogeneity. Two-way analyses of variances (two-way ANOVA) were performed on the data from short-term experiments to indicate overall action and interaction of the factors. Specific differences between groups were further discerned by LSD-test. In the case of long-term experiments, means within days were compared by one-way analysis of variance, followed by LSD-test to discern specific differences from the control. Level of significance for LSD-test was accepted at $P < 0.05$.

5.3. RESULTS

The results presented here demonstrate the effects of ambient aluminium and calcium concentrations and, ambient pH on Na^+/K^+ and Ca^{2+} -ATPase activity in tilapia gills during varying periods of exposure.

5.3.1. Experiment 1

Fish maintained in LCW conditions at both pH levels (pH 6.8 and 5.2) showed significantly (LSD-test) increased levels of Na^+/K^+ -ATPase activity in gills than the corresponding groups of fish kept under HCW conditions (Fig. 5.1.a.). This action of ambient calcium concentration was independent and significant ($P < 0.001$; two-way analysis of variance). The low pH (5.2) tested in the present study did not significantly affect enzyme activity in fish during the present experimental period, although the level was slightly elevated at low pH and LCW conditions (Fig.5.1a.).

The Ca^{2+} -ATPase activity was also higher in fish under LCW conditions at both pH levels (5.1b). However, LSD-test indicated a significant difference only in fish exposed to low pH environment. Two-way analysis of variance showed that the overall effect of calcium was significant at $P < 0.01$. Again, ambient pH had no marked effects on Ca^{2+} -ATPase activity in fish.

5.3.2. Experiment 2

5.3.2.1. Water Quality

Table-5.1. shows the data on measured water quality parameters during a 4 d acid/aluminium exposure in LCW and HCW conditions. There was little deviation in the measured parameters from what was intended. As with the other experiments, sodium concentrations in the exposure media increased considerably under all exposure

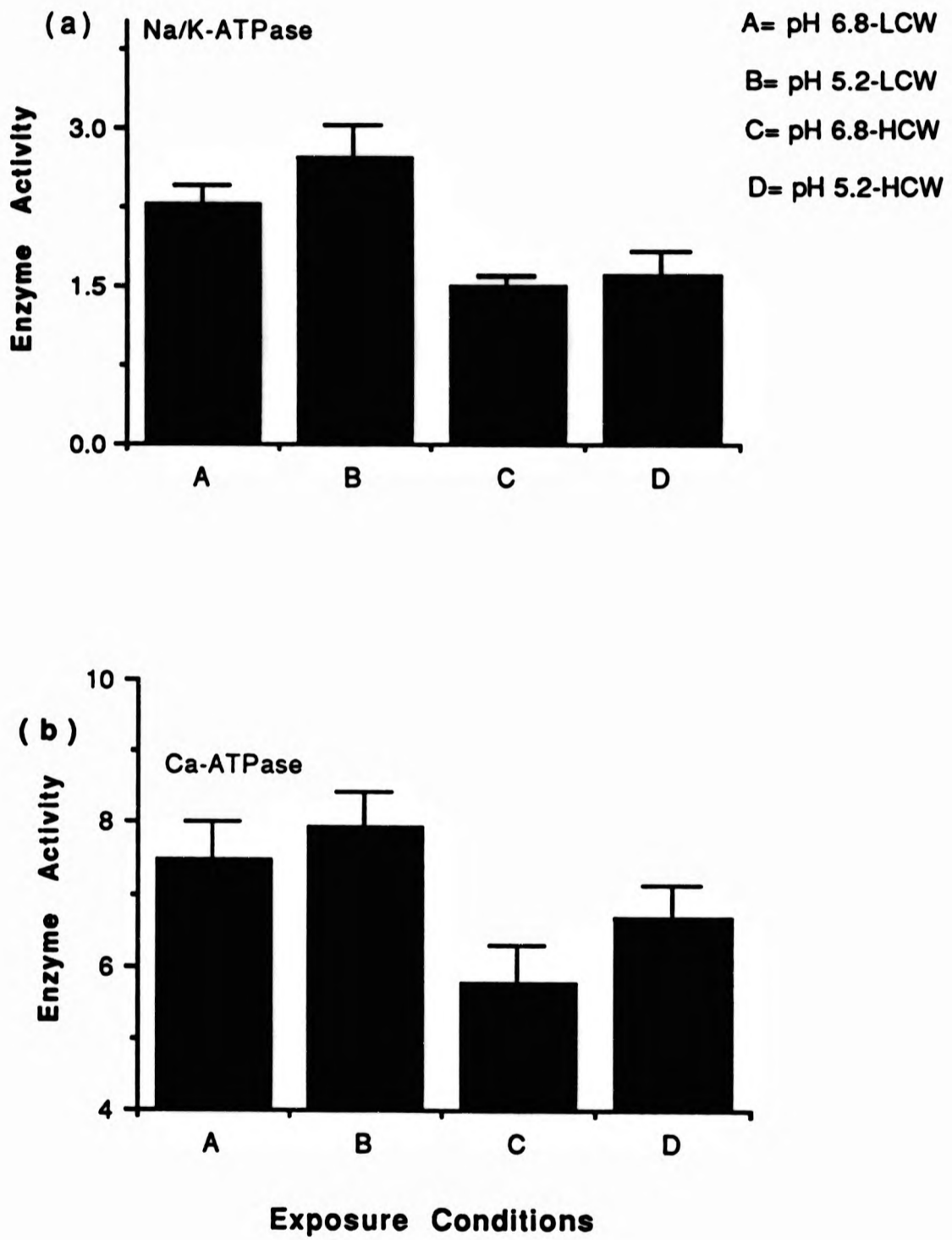

Fig.5.1. Changes in (a) Na^{+/K+}- and (b) Ca²⁺-ATPase activity (µM/mg protein/h) in tilapia gills exposed to low pH (5.2) for 4 days under LCW and HCW conditions. Values are arithmetic means ± (n=6).

Table-5.1. Measured water quality parameters in the exposure media during short-term (4 d) experiment in LCW (0.6 mg Ca/l) and HCW (16.00 mg Ca/l) conditions. Nominal sodium concentration and pH were 1.10 mg/l and 5.2, respectively. Values are arithmetic means \pm S.D. (n=4).

Measured parameters	Nominal aluminium concentrations	
	0 ug/l	300 ug/l
	LCW	HCW
Aluminium ($\mu\text{g/l}$)	3.00 \pm 2.58	4.50 \pm 2.50
Calcium (mg/l)	0.62 \pm 0.08	14.21 \pm 0.82
Sodium (mg/l)	1.59 \pm 0.09	1.56 \pm 0.10
pH	5.18 \pm 0.04	5.16 \pm 0.06
	LCW	HCW
	278.50 \pm 19.00	288.00 \pm 17.08
	0.66 \pm 0.08	14.89 \pm 0.99
	1.70 \pm 0.10	1.65 \pm 0.12
	5.17 \pm 0.04	5.16 \pm 0.03

conditions. The reasons for these variations are already discussed in Chapter 3.

5.3.2.2. Enzyme Activity

Fish exposed to 0 $\mu\text{g Al l}^{-1}$ in LCW conditions showed significantly elevated levels of Na^+/K^+ -ATPase activity compared with the corresponding groups of fish maintained in HCW conditions (Fig.5.2a.). No such action of LCW on Na^+/K^+ -ATPase activity was evident in fish at the elevated level of aluminium. The presence of aluminium (300 $\mu\text{g l}^{-1}$) in the exposure media resulted in reduction in Na^+/K^+ -ATPase activity in both LCW and HCW conditions, although significant difference could only be detected in LCW fish (LSD-test) (Fig.5.2a.). The overall action of exposure calcium and aluminium concentrations were significant at $P < 0.05$ and $P < 0.001$, respectively (two-way analysis of variance). However, there was a significant interaction in the effects of the two factors ($P = 0.05$; two-way analysis of variance) indicating the ameliorating effects of external calcium on aluminium-induced changes in Na^+/K^+ -ATPase activity.

The Ca^{2+} -ATPase activity in fish at both aluminium levels in LCW conditions were significantly (LSD-test) higher than the corresponding groups of fish exposed under HCW conditions (Fig.5.2b.). This action of ambient calcium concentrations on Ca^{2+} -ATPase activity was highly significant ($P < 0.001$; two-way analysis of variance). Although exposure to 300 $\mu\text{g Al l}^{-1}$ resulted in a considerable reduction in Ca^{2+} -ATPase activity, but two-way analysis of variance revealed no significant difference in the action of aluminium concentrations on the enzyme activity.

5.3.2.3. Gill Aluminium Content

The aluminium content in gills of tilapia exposed to 300 $\mu\text{g Al l}^{-1}$ in LCW and HCW conditions were 554 ± 76 and $498 \pm 52 \mu\text{g Al g}^{-1}$ dry tissue, respectively, and that of fish exposed at 0 $\mu\text{g Al l}^{-1}$ in both LCW and HCW conditions were 9.58 ± 2.21 and

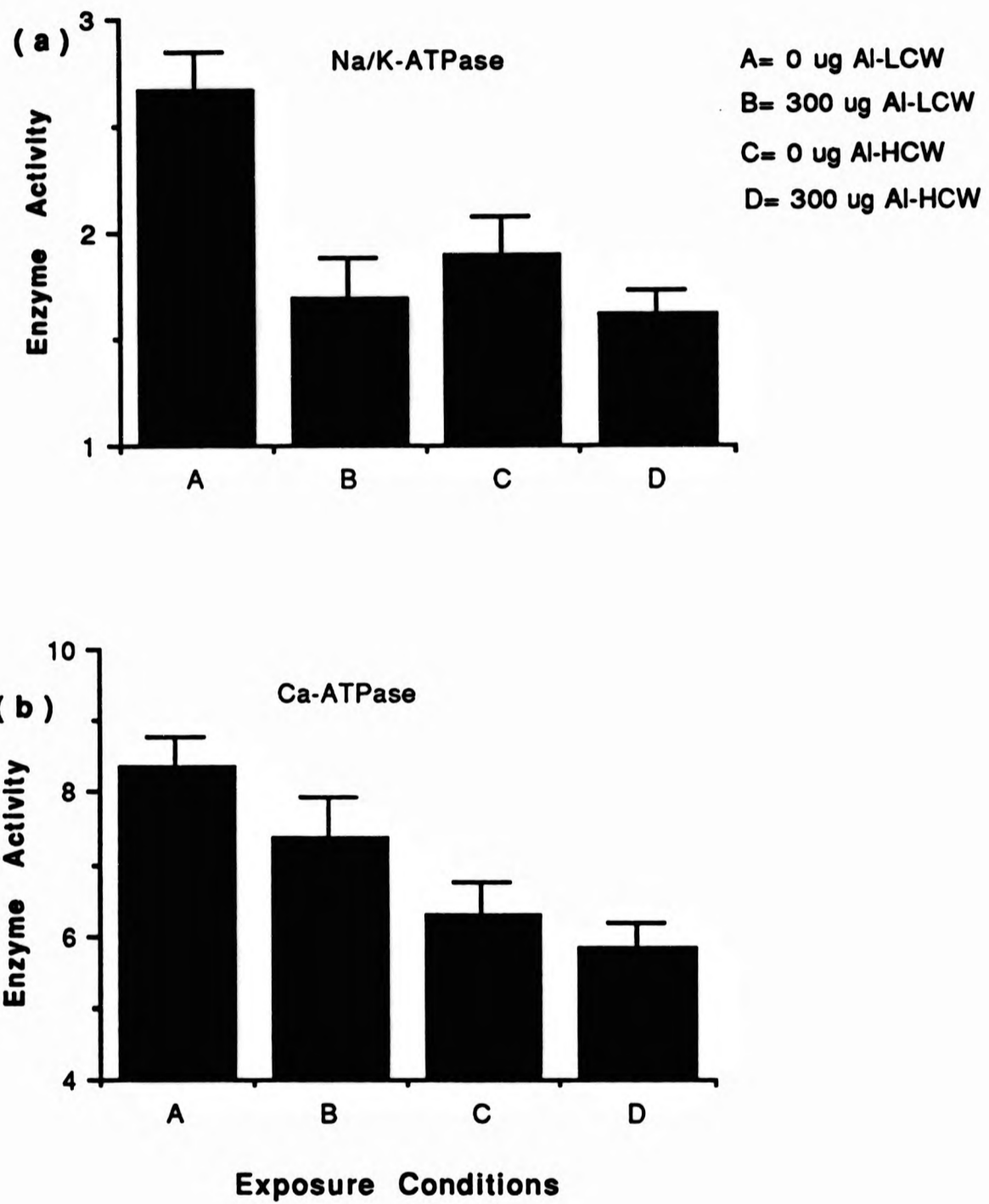

Fig.5.2. Changes in (a) Na^+/K^+ - and (b) Ca^{2+} -ATPase activity ($\mu\text{M Pi/mg protein/h}$) in tilapia gills during short-term (4 d) exposure to acid/aluminium in LCW and HCW conditions. Values are arithmetic means \pm S. E. (n = 8).

13.27 ± 2.52 µg Al g⁻¹ dry tissue, respectively. As evident from the data, there was no marked differences in gill aluminium content between LCW and HCW fish.

5.3.3. Experiment Series 3

Although the LCW and HCW experiments were conducted in separate trials, for convenience the results are presented together. Attention was paid to trends in the results.

5.3.3.1. Water Quality

Table-5.2 and 5.3. present the data on measured water quality parameters. The results show that there were little variations between actual and nominal concentrations in measured parameters except that of sodium concentrations which increased markedly under all exposure conditions.

5.3.3.2. Enzyme Activity

Na⁺/K⁺-ATPase

LCW Experiment (Fig. 5.3a.): Exposure to 150 µg Al l⁻¹ induced a significant increase in Na⁺/K⁺-ATPase activity by day 2 of exposure compared with the control fish maintained without added aluminium. However, the enzyme activity significantly declined to below the control value by day 21 of exposure. Fish exposed to 100 µg Al l⁻¹ also showed increased activity on day 9, the activity again declined considerably below that of the controls by day 21 of exposure. However, in neither case were the changes significant. A significant increase in enzyme activity was, however, observed in fish exposed at aluminium concentration 50 µg l⁻¹ after 21 days of exposure. The control group of fish did not show any noticeable changes in enzyme activity over the exposure period.

Table-5.2. Measured water quality parameters in the exposure media during a 21 day experiment in LCW conditions (Nominal concentrations of calcium and sodium were 0.6 (0.015 mmol/l) and 1.10 mg/l (0.48 mmol/l), respectively. Nominal pH was 5.2. Values are arithmetic means + S.D. (n=5-6).

Nominal Al conc. (µg/l)	Measured water quality parameters			
	Aluminium (µg/l)	Calcium (mg/l)	Sodium (mg/l)	pH
150	146.00 + 9.70	0.63 + 0.07	1.61 + 0.14	5.15+ 0.06
100	95.67 +10.27	0.61 + 0.07	1.52 + 0.12	5.16+ 0.06
50	52.00 ± 7.97	0.63 + 0.09	1.53 + 0.16	5.16+ 0.07
0	2.40 + 1.51	0.58 ± 0.08	1.59 + 0.10	5.18+ 0.05

Table-5.3. Measured water quality parameters in the exposure media during a 21 day experiment in HCW conditions. Nominal concentrations of calcium and sodium were 16.0 (0.4 mmol/l) and 1.10 mg/l (0.48 mmol/l), respectively. Nominal pH was 5.2. Values are arithmetic means and \pm S.D. (n=5-6).

Nominal Al conc. ($\mu\text{g/l}$)	Measured water quality parameters			
	Aluminium ($\mu\text{g/l}$)	Calcium (mg/l)	Sodium (mg/l)	pH
150	149.40 \pm 9.63	14.97 \pm 1.20	1.51 \pm 0.12	5.14 \pm 0.06
100	92.20 \pm 6.22	15.50 \pm 1.49	1.44 \pm 0.18	5.18 \pm 0.04
50	45.80 \pm 7.50	14.83 \pm 1.16	1.45 \pm 0.17	5.16 \pm 0.08
0	2.60 \pm 2.07	15.14 \pm 1.12	1.38 \pm 0.10	5.18 \pm 0.04

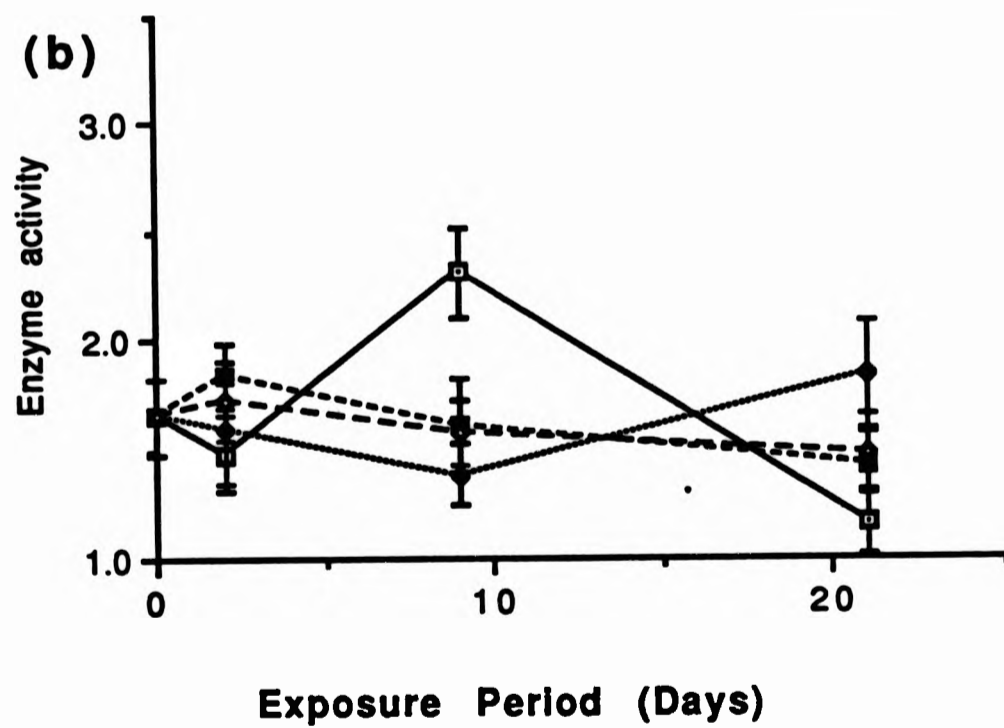
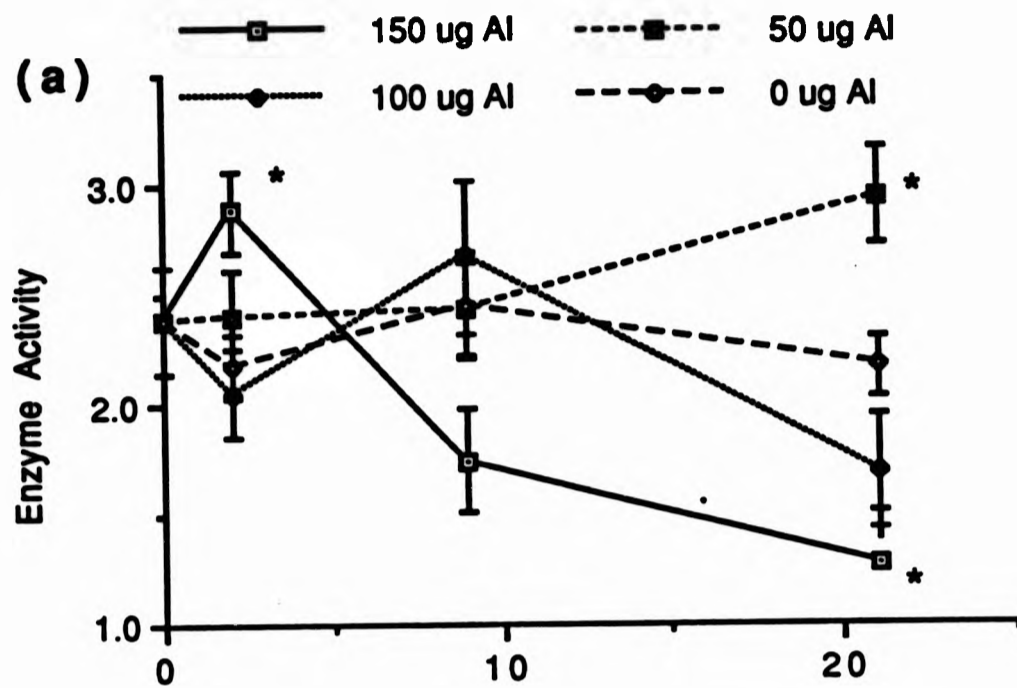

Fig. 5.3. . Changes in Na^+/K^+ -ATPase activity ($\mu\text{M Pi}/\text{mg protein}/\text{h}$) in gills of tilapia exposed to different aluminium concentrations at pH 5.2 during 21 days of exposure in LCW (a) and HCW (b) conditions. Asteriks indicate significant difference (LSD-test; $P < 0.05$) from control (0 g Al l^{-1}) fish. Values are arithmetic means \pm S. E. ($n=6$).

HCW Experiment (Fig.5.3b.): Fish exposed to $150 \mu\text{g Al l}^{-1}$ showed a significant increase in Na^+/K^+ -ATPase activity on day 9 of exposure. However, the activity again declined to below the control fish by day 21 of exposure, although this reduction in enzyme activity was not statistically significant when compared with the control fish. On the other hand, exposure to $100 \mu\text{g Al l}^{-1}$ caused a significant increase in the enzyme activity over controls by day 21 of exposure. No marked changes were apparent in Na^+/K^+ -ATPase activity in $50 \mu\text{g Al l}^{-1}$ -exposed or in control fish.

Ca^{2+} -ATPase

LCW Experiment (Fig.5.4a.): A significant reduction in Ca^{2+} -ATPase activity was recorded in fish exposed to $150 \mu\text{g Al l}^{-1}$ only at day 21 of exposure. In comparison with the control, the fish at aluminium concentration of $100 \mu\text{g Al l}^{-1}$ also showed a considerable decline (approximately 19% compared to control) in enzyme activity at the termination of experiment (day 21), although this was found to be statistically insignificant. No noticeable changes were evident in the data on Ca^{2+} -ATPase in $50 \mu\text{g Al l}^{-1}$ -exposed or in control fish.

HCW Experiment (Fig.5.4b.): Fish exposed to 150 and $100 \mu\text{g Al l}^{-1}$ showed slight, albeit insignificant, decreases in Ca^{2+} -ATPase activity at the termination of experiment but compared to control fish no significant difference could be detected in the data. Other groups of fish did not show any marked changes in the enzyme data.

5.3.3.3. Gill Aluminium Content

Table-5.4. shows the results on gill aluminium content in fish exposed to different aluminium concentrations in acidic environment during long-term experiments in both LCW and HCW conditions. Accumulation of aluminium occurred throughout the exposure period although at a much lower rate during the later period of exposures.

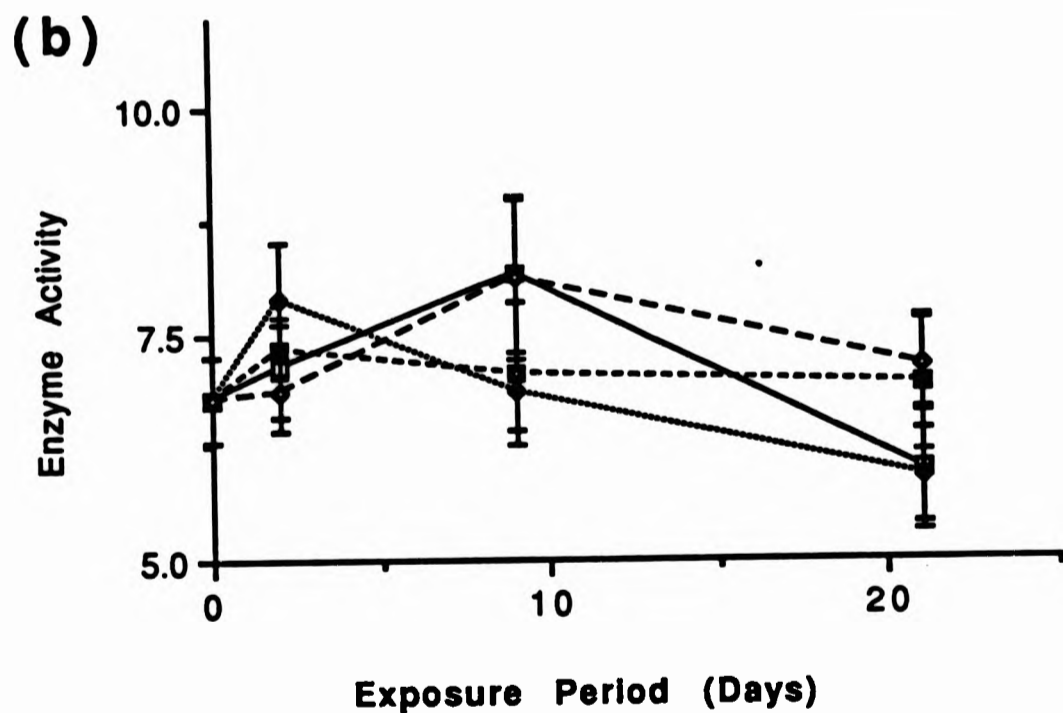
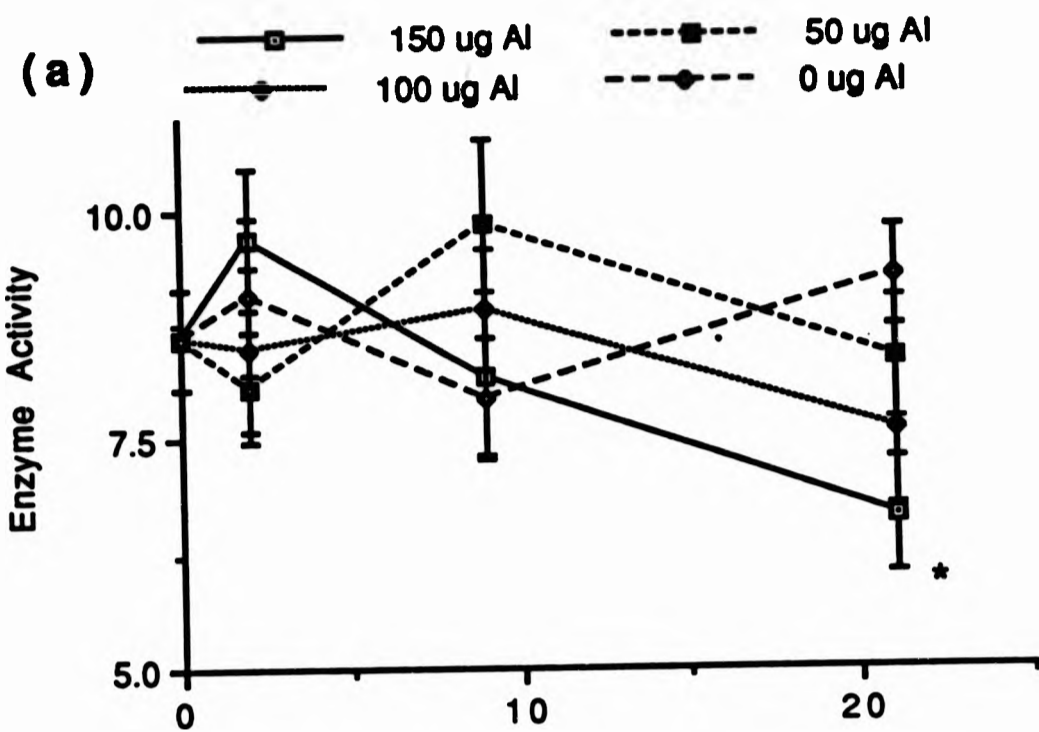

Fig. 5.4 Changes in Ca^{2+} -ATPase activity ($\mu\text{M Pi/mg protein/h}$) in gills of tilapia exposed to different aluminium concentrations at pH 5.2 during 21 days of exposure in LCW (a) and HCW (b) conditions. Asterisks indicate significant difference (LSD-test; $P < 0.05$) from control (0 g Al l^{-1}) fish. Values are arithmetic means \pm S. E. ($n=6$).

Table-5.4. Aluminium content ($\mu\text{g/g}$ dry tissue) in gills of tilapia during chronic experiments in LCW and HCW conditions. Values are arithmetic means \pm S. D. (n=5).

Nominal Al concs.	LCW Experiment		HCW Experiment	
	Days after Exposure		Days after exposure	
	2	21	2	21
150	181 \pm 50	247 \pm 46	262 \pm 67	275 \pm 51
100	167 \pm 60	190 \pm 52	213 \pm 32	172 \pm 60
50	72 \pm 21	114 \pm 33	129 \pm 32	121 \pm 25
0	11 \pm 6	8 \pm 6	13 \pm 7	10 \pm 6

Visual inspection of data revealed no marked differences in gill aluminium content between LCW and HCW fish.

5.3.4. In Vitro Experiment

Fig. 5.5. shows the *in vitro* effects of aluminium on Na^+/K^+ and Ca^{2+} -ATPase activity. The activity of both the enzymes was inhibited by the presence of aluminium in the incubation media. However, Na^+/K^+ -ATPase was more sensitive to aluminium than Ca^{2+} -ATPase.

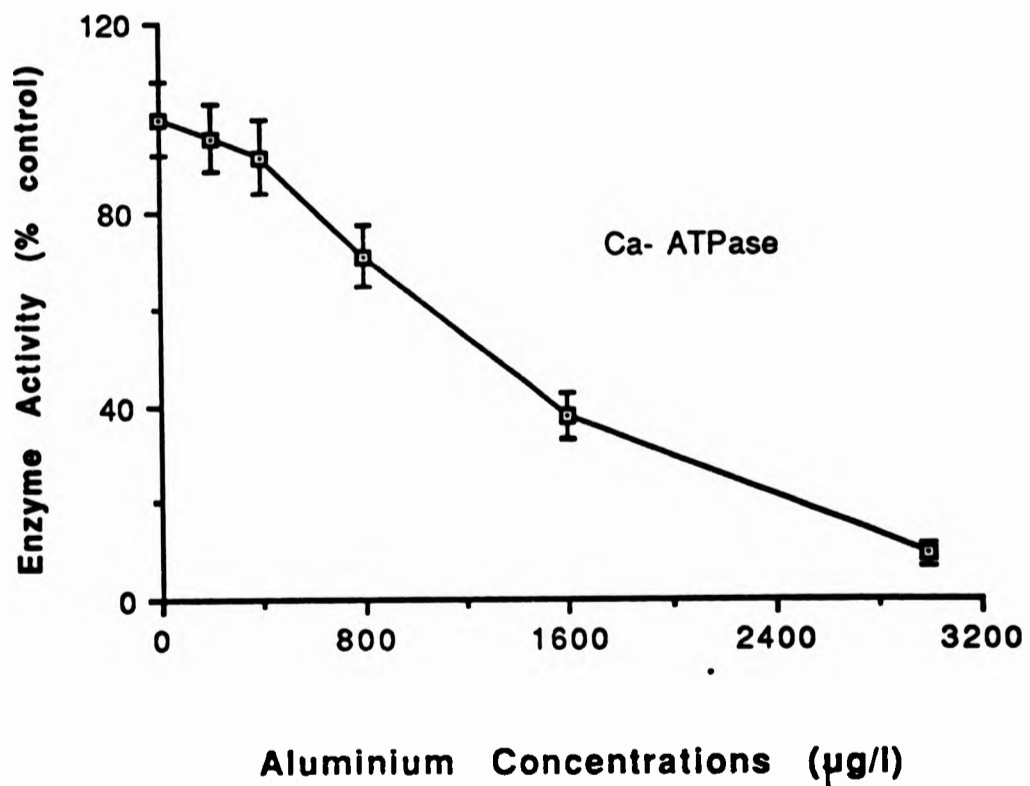
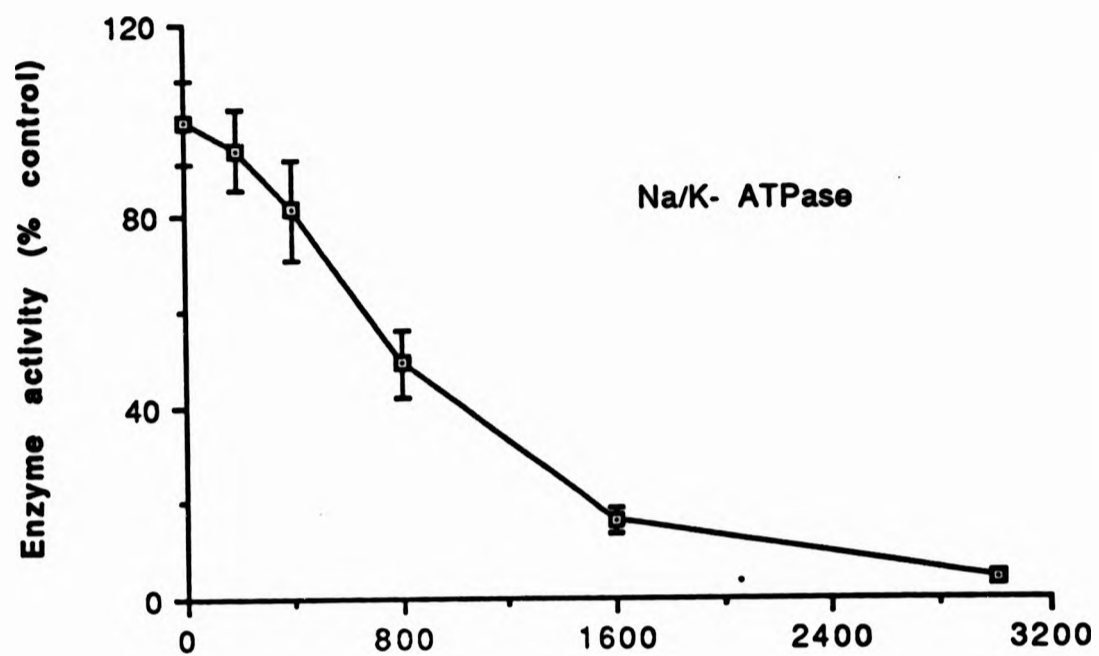

Fig.5.5.7 *In vitro* effects of aluminium on gill Na⁺/K⁺- and Ca²⁺-ATPase in tilapia. Values are arithmetic means ± S.E. of two series of experiments in duplicate. Percent enzyme activity are calculated from control (0 ug Al/l treatment) value.

5.4. DISCUSSION

The specific Na^+/K^+ -ATPase activity reported here for tilapia in gill homogenate under acclimation conditions (at circumneutral pH) either in LCW or HCW ranged from 1.49 to 2.56 $\mu\text{M Pi protein mg}^{-1} \text{ h}^{-1}$. These values lie well within the range previously reported for freshwater teleost gill homogenates (Doneen, 1982; DeRenzis and Bornancin, 1984; Dange, 1985; 1986; Moon, 1978). In fish literature the lowest value (0.57 $\mu\text{M Pi protein mg}^{-1} \text{ h}^{-1}$) for Na^+/K^+ -ATPase in gill homogenate has been reported for the tilapia, *Tilapia (Oreochromis) mossambica*, by Dharmamba *et al.* (1975). Dange (1985), however, recorded a much higher Na^+/K^+ -ATPase activity (5.85 $\mu\text{M Pi protein mg}^{-1} \text{ h}^{-1}$) in gill homogenates of the same fish. Nonetheless, both the reported values differ widely from those of the present study. Although species difference probably exists, factors inherent to homogenate preparation, i.e. addition of detergents (Johnson *et al.*, 1977; Doneen, 1981), pre-incubation of enzyme suspension (Trigari, 1985), enzyme assay temperature (Sargent *et al.*, 1975; Watson and Beamish, 1980; 1981) and ambient water quality (this study), certainly contribute the larger part to the differences observed. For example, Watson and Beamish (1980, 1981) convincingly demonstrated that enzyme suspensions incubated at 37°C resulted in a 2-3 fold higher Na^+/K^+ -ATPase activity than those incubated at 11°C. Dharmamba *et al.* (ibid) incubated the homogenate at 21°C and this might have contributed to the observed lower enzyme activity. Moreover, the ionic strength employed in their reaction medium appears to be sub-optimal compared with that of the present study. This may also contribute to some extent to the observed differences. Therefore, a meaningful comparison of values reported in different papers is difficult.

The specific Ca^{2+} -ATPase activity observed in the present study in gill homogenate of tilapia under acclimation condition (at circumneutral pH) varied from 6.81 to 8.60 μM

Pi protein $\text{mg}^{-1} \text{h}^{-1}$. These values are also within the reported range for the freshwater teleost gill homogenate (see DeRenzis and Bornancin, 1984; for review).

One important aspect of the measurement of Ca^{2+} -ATPase activity in tissue must be discussed. The most common method used for the measurement of Ca^{2+} -dependent ATPase activity involves the incubation of enzymes in the presence and absence of Ca^{2+} in the reaction media. However, it has been suggested that calcium can be substituted for magnesium in the activation of Mg^{2+} -ATPase (Ma *et al.*, 1974). It has also been reported that alkaline phosphatase may be activated by calcium (Ghijsen *et al.*, 1980; Russel *et al.*, 1972). This enzyme is involved in phosphate transport and does not transport calcium (McComb *et al.*, 1979). Therefore, the measured Ca^{2+} -ATPase in the tissue may contain a heterogenous pool of alkaline phosphatase and Mg^{2+} -ATPase. One should therefore be cautious when relating observed enzyme activity to ionic exchanges across gills.

In the present study, enzyme activity in the gills was measured by the standard incubation method. Direct estimation of ATPase activity under optimum conditions (as in the present case) will give a measure of the total capacity of the reciprocal exchange of the ions. Under normal conditions, not all the enzyme sites in the tissue may be available for the transportation of ions or may not be working at their maximum capacity.

Effects of external calcium

The present study has clearly demonstrated the effects of environmental calcium concentrations on ATPase activity in tilapia gills. Fish acclimated in LCW conditions (at circumneutral pH) had significantly higher Na^+/K^+ -ATPase activity in gills than fish acclimated under HCW conditions. Interestingly, this significant increase in enzyme

activity occurred in LCW fish despite the fact that the environmental sodium concentrations in both LCW and HCW media were similar.

A comprehensive literature search revealed no comparable data on the effects of external calcium concentrations on Na^+/K^+ -ATPase activity under laboratory conditions. However, it is well known that in freshwater fish transport ATPase activity is associated with the active uptake of ions from the environment and published data indicate that the level of ATPase activity is positively related to the degree of uptake of ions (see Doneen, 1981; Dange, 1985; and see also DeRenzis and Bomancin, 1984). Therefore, the increased enzyme activity observed in the present study could be involved with the increased uptake of ions. Indeed, external calcium concentrations have been shown to have marked effect on sodium influx both in freshwater and marine fish (Cuthbert and Maetz, 1972; Eddy, 1975; Maetz and Bomancin, 1975; McDonald and Milligan, 1988). For example, at circumneutral pH, removal of calcium from the medium doubled sodium influx in carps, *Carassius auratus*, while efflux was unaffected (Cuthbert and Maetz, 1972). Eddy (1975), also using the same fish at circumneutral pH, found that addition of calcium to the external media caused sodium influx to be halved. Thus the observed increased Na^+/K^+ -ATPase activity in the present study in LCW fish seems to be valid.

In general, the Ca^{2+} -ATPase activity increased in fish maintained under LCW conditions compared with those kept in HCW. In agreement with the present study Fenwick (1979) and Flik *et al.* (1983) demonstrated increases in Ca^{2+} -ATPase activity during chronic exposure to reduced ambient calcium in eels, *Anguilla anguilla*, and tilapia, *Sarotherodon (Oreochromis) mossambica*, respectively, although this was not observed by Mayer-Gostan *et al.* (1983) in the killifish, *Fundulus heteroclitus*. Adaptation to low calcium waters has also been shown to increase Ca^{2+} -ATPase activity in gill microsomal

fraction in trout (P.G. McWilliams, unpublished data; quoted in Potts and McWilliams, 1989). Flux measurement studies with trout, *S. gairdneri*, and tilapia, *O. mossambicus*, by Perry and Wood (1985) and Flik *et al.* (1986), respectively, also support the increased enzyme activity observed in this study. Both studies reported higher influx in low calcium water fish than in fish acclimated in high calcium waters and strongly indicated the possible involvement of increased activity of Ca^{2+} -ATPase.

How environmental calcium concentrations modulate ATPase activity in gills is not well understood. However, the following explanation may be offered. Reduction of ambient calcium concentrations is known to increase the permeability of gill epithelium to ions (Eddy, 1975; McWilliams, 1982; see also Chapter 1), leading to temporary ionic imbalance (McDonald *et al.*, 1980). The transepithelial potential (TEP) is also affected by external calcium, becoming more positive as calcium levels are elevated (Eddy, 1975; McWilliams and Potts, 1978; Perry and Wood, 1985), thus causing greater efflux in low calcium waters. Therefore, the general augmentation of gill ATPase activity could result from the diffusional loss of ions due to increased permeability. The ultimate reduction in ion concentration could, in turn, act as a signal for gill ATPases to increase the absorption of electrolytes.

Effects of pH

In the present study, exposure to pH 5.2 for four days resulted in an increase, albeit insignificant, in gill Na^+/K^+ and Ca^{2+} -ATPase activity in tilapia under LCW conditions. No clear-cut changes were evident in the enzyme data in HCW fish. The results are consistent with the lack of significant changes in plasma sodium and calcium levels observed in tilapia under comparable exposure conditions (see Chapter 3). In a recent study, Balm *et al.* (1988) reported a significant decrease in the Na^+/K^+ -ATPase activity in tilapia, *O. mossambicus*, after five days of exposure to pH 3.5, although the level

had returned to in excess of the control by week 3. This finding of reduction in ATPase activity, however, does not contradict the present results, since the pH effect is largely determined by the exposure (ambient) pH level, length of exposure and sensitivity of the species to pH changes. Exposure of Atlantic salmon, *S. salar*, to pH 5.0 for 4-7 days increased the Na⁺/K⁺-ATPase activity (Staurnes *et al.*, 1984b). By contrast, Saunders *et al.* (1983) reported a significant decrease in the Na⁺/K⁺-ATPase activity in the same species exposed to pH 4.8. McKeown *et al.*, (1985) found significantly higher Na⁺/K⁺-ATPase activity in rainbow trout, *S. gairdneri*, exposed at pH 4.9 but not at pH 5.4 during a 21 day exposure period. The latter authors (McKeown *et al.*) in the same study did not find any changes in Na⁺/K⁺-ATPase activity in white suckers, *Catostomus macrocheilus*, an acid resistant species, in the pH range 4.9-6.8.

Similarly, in agreement with the present study, McKeown *et al.*, (1985) and Parker *et al.* (1985) also did not find any changes in Ca²⁺-ATPase activity in rainbow trout in the pH range 5.0-5.1 and 4.9-6.8, respectively. However, in a recent study, adaptation to low calcium acidic pH has been shown to increase gill Ca²⁺-ATPase in rainbow trout (P.G. McWilliams; unpublished results: mentioned in Potts and McWilliams, 1989).

Effects of acid/aluminium

In the present study, under *in vitro* exposure conditions aluminium inhibited the activity of both Na⁺/K⁺ and Ca²⁺-ATPase enzymes. However, under conditions of *in vivo* exposure, both inhibitory and stimulatory effects of acid/aluminium on both enzymes were observed. These actions of acid/aluminium exposure appear to be dependent upon ambient aluminium and calcium concentrations as well as exposure duration.

The observed inhibition in the Na⁺/K⁺-ATPase activity in the present study is in

agreement with the findings of Staumes *et al.* (1984b). These authors recorded a significant reduction (24%) in gill Na^+/K^+ -ATPase activity in Atlantic salmon exposed to $200 \mu\text{g Al l}^{-1}$ in acidic environment for 4-7 days. The ability of aluminium to inhibit Na^+/K^+ -ATPase activity has also been demonstrated earlier in an *in vitro* studies by Riedel and Christensen (1979). The present results of enzyme inhibition are also consistent with plasma sodium concentrations observed under comparable exposure conditions (see Chapter 3 and 4).

The specific biochemical action of trace metals on Na^+/K^+ -ATPase activity is poorly understood. However, there have been numerous suggestions that metal ions probably bind to specific sites on protein (enzyme) molecules and/or enzyme-cofactors, leading to conformational changes which could affect enzyme function (Karlson, 1970; Jackim, 1974; Ochiai, 1977; Watson and Beamish, 1980). Aluminium binding with protein and enzyme-cofactors has been demonstrated in a number of *in vitro* studies and has been shown to interfere with enzyme functions (see Section 5.1). Thus, inhibition of tilapia gill Na^+/K^+ -ATPase activity may be related to interaction between aluminium and the sulfhydryl group (-SH) on the enzyme molecule or with magnesium-dependent cofactor. These sulfhydryl group may be located at the active catalytic site or at some distance from the catalytic site. At any rate, they are essential to catalytic activity because they help to maintain the specific three-dimensional configuration of the Na^+/K^+ -ATPase molecules (Lehninger, 1972). Enzyme sulfhydryl groups are particularly sensitive to metal ions as they inhibit reactions reliant on free (-SH) groups (Karlson, 1970). The enzyme Na^+/K^+ -ATPase is a Mg^{2+} -dependent enzyme and the ultimate substrate in the enzyme reaction is Mg-ATP complex. Aluminium can displace magnesium from Mg-ATP complex and may form an Al-ATP complex, inhibiting enzyme action (Trapp, 1986.) Binding of aluminium with ATP was confirmed by NMR studies (Laussac and Laurent, 1980). Inhibition of Na^+/K^+ -ATPase, may, therefore, be a function of

aluminium in activating changes in configuration in the enzyme molecule through its action on sulfhydryl (-SH) group and/or on magnesium-cofactor.

Inhibition of Ca^{2+} -ATPase activity was only limited to certain concentrations at certain sampling points. Unlike Na^+/K^+ -ATPase there was, however, a lack of general stimulation of increased activity under acid/aluminium exposure conditions. It is well accepted that aluminium and calcium metabolism are closely related and interact for binding sites and it is suggested that aluminium may bind to the same ligand as calcium (Farnell *et al.*, 1985; Trapp, 1986). Aluminium has been shown to alter calcium binding by altering the configuration of protein as appears to occur when aluminium binds to calmodulin (Siegel and Haug, 1983a; 1983b). Calcium transport is calmodulin-dependent and the later stimulates the Ca^{2+} - Mg^{2+} -ATPase component of the calcium pump. Siegel and Haug (*ibid*) reported that aluminium induces changes in calmodulin which blocks the interaction of calmodulin with receptor enzymes, including Ca^{2+} and Mg^{2+} -ATPase. It therefore seems likely that aluminium exerts its action on Ca^{2+} -ATPase either by displacing calcium from its binding sites on the enzyme or by interacting with calmodulin or a combination of both.

In the present study, under certain *in vivo* exposure conditions, acid/aluminium stimulated Na^+/K^+ -ATPase activity in tilapia gills. Metal-induced increases in the ATPase activities in fish have also been reported in a number of *in vivo* studies (Watson and Beamish, 1980; Stagg and Shuttleworth, 1982; see also Bansal *et al.*, 1985). However, these authors offered no explanation for these increases. In the present study, in general, the increases in the enzyme activity were observed at the higher aluminium concentrations during the initial period of exposure and at the lower aluminium concentrations during the later period of exposure. Despite increases in enzyme activity there were no corresponding increases in plasma sodium concentrations

under comparable exposure conditions (see Chapter 3 and 4), rather decreased sodium concentrations were observed under certain exposure conditions, suggesting that the increases in enzyme activity were probably a compensatory response mechanism. The decreased sodium concentrations observed in some samples despite increased enzyme activity indicate that apparently the compensations were not complete. Since aluminium is known to inhibit Na^+/K^+ -ATPase activity both in *in vivo* and *in vitro* exposure conditions (Riedel and Christensen, 1979; Staurnes *et al.*, 1984 and this study), the increase in enzyme activity ostensibly was not the direct effect of metal ions on the enzyme molecules. As discussed above the increase in enzyme activity could have resulted from the reduction in plasma sodium concentrations arising from increased efflux. It is well known that aluminium stimulates sodium efflux in fish. Again, the observed increases in enzyme activity do not necessarily imply that no inhibition of enzymes occurred in fish exposed to those exposure conditions; it may have occurred, but due to greater increase, the smaller inhibition in the enzyme activity probably was not apparent.

The reported changes in the enzyme activity could have been resulted from the changes in the total number of molecules, or changes in the kinetic properties or changes in the proportion of active molecules.

Effects of external calcium on aluminium toxicity

It is apparent from the results of the present study that aluminium-induced inhibition of ATPase activity was reduced by external calcium concentrations. This action of calcium was partial and was not clear-cut in fish at higher aluminium concentrations, although the results from the long-term experiments show that inhibition caused by low levels of aluminium was completely mitigated by higher calcium concentrations in the exposure media. Since gill aluminium data showed no differences between LCW and

HCW fish, it is unlikely that this protective action of aluminium lies in gill aluminium load. It is also not understood whether any physiological phenomenon is involved in this action. Since external calcium concentrations do not influence muscle calcium levels (Chapter 3 & 4), it is unlikely that calcium-mediated enzymatic functions were disrupted. However, it seems likely that protection afforded by calcium probably resides in the interaction of calcium, aluminium and gill surface ligands which determine the degree of general stress in fish and that the general physiological status of fish may in turn influence the enzyme turnover, rate of synthesis or catalytic power of the enzyme molecules.

Obviously, observed inhibition in ATPase activity will reduce the osmoregulatory capacity of fish. In addition, increased gill ATPase activities associated with aluminium exposure represent a rise in energy expenditure and metabolism because of the increased rate of ATP hydrolysis. Although the metabolic cost of maintaining gill ATPase enzyme functions may be comparatively small when considering the whole organism, increases in the activities in those enzymes sustained over time may incur a significant metabolic cost.

CHAPTER 6
EFFECTS OF ACID/ALUMINIUM EXPOSURE ON THE CALCIUM
METABOLISM IN TILAPIA, *OREOCHROMIS NILOTICUS*.

6.1. INTRODUCTION

Calcium plays a central role in enzyme systems control (e.g. energy transduction), membrane permeability and stability, transport, cell division, hormonal and neural action, secretion and skeletal function. Maintenance of appropriate calcium concentrations (extracellular, cellular and cytoplasmic and within organelle) and integrity of associated transport systems are vital to much of the physiology of an organism (Krane and Potts, 1980; Barrit, 1982; Nicholls, 1982). A toxicant affecting these activities may thus be expected to lead to a complex syndrome.

Anomalies in calcium metabolism in fish in acidic environments were first reported in a field study by Beamish and Harvey (1972) and by Beamish in a laboratory study (1972). The authors found large-scale deformities in white suckers, *Catostomus commersoni*, in an acidic lake. Similar abnormalities, including shorter caudal vertebrae, deformed caudal fins and reduced calcium concentration in vertebrae in a population of white suckers in an acid stressed lake were reported in another study by Beamish *et al.* (1975) and also by Fraser and Harvey (1982). In one of the above studies (Beamish *et al.*, 1975) it was reported that female white suckers did not display the normal pre-spawning surge in calcium concentrations that is necessary for vitellogenesis and did not appear to spawn successfully. By contrast, white suckers from a nearby non-acidic lake did spawn successfully. Similar abnormalities in pre-spawning surge in plasma calcium levels were also described in a laboratory experiment with brook trout, *Salvelinus fontinalis*, by Mount *et al.* (1988a). In order to explain the population decline in acidic soft water environment an impairment in calcium metabolism has been linked to recruitment failure (Beamish *et al.*, 1975; Spry *et al.*, 1981).

Similarly, there are several laboratory studies that have convincingly demonstrated

impairment of calcium metabolism, including inhibition of early ossification and impaired net whole body uptake of calcium in yolk-sac fry (Nelson, 1982; Reader *et al.*, 1988; 1989), deficiency in otolith calcium carbonate deposition (Hutlberg, 1977) and impaired calcification of exoskeleton in crayfish *Oronectes* sp. (Malley, 1980) during acid and acid/trace metal exposure. In those cases the fish grew with time and displayed a net uptake of calcium, although at a very much lower rate than among control fish. However, it is not well known what happens to calcium balance when a normal fish is introduced to an acidic environment. Most authors, who exposed naive fish to acid and trace metal contaminated acid waters, have found little or no effect or even elevated plasma and muscle calcium concentrations (Neville, 1979; McDonald *et al.*, 1980; Giles *et al.*, 1984; Witters, 1987; Wendelaar Bonga and Dederen, 1987; Audet *et al.*, 1988; Wood *et al.*, 1988b; Playle *et al.*, 1989). It is well known that teleosts can maintain plasma calcium levels under diverse environmental conditions and that skeletal calcium can play an important role (Simmons, 1971; Dacke, 1979; Perry and Wood, 1985). In addition to supportive and protective functions, most vertebrate skeletons act as physiological reservoirs of calcium, phosphate and other ions (Weiss and Watabe, 1978) and these minerals may be utilized on demand by fish (Dacke, 1979). For example, killifish, *Fundulus heteroclitus*, kept in deionized water can maintain plasma calcium concentrations despite a loss of calcium into the surrounding medium (Pang *et al.*, 1973). Flemming (1974) has mentioned that fish skeletal calcium freely moves into the exchangeable calcium pool and hypothesized that bone reabsorption might occur if fish are introduced into a stressful environment.

It has been suggested that bone reabsorption may take place during acid and associated metal-induced stress, thus changes in plasma calcium concentrations may not be evident, even if they had occurred due to ionoregulatory disruption caused by acid/trace metals. For example, McDonald and Wood (1981) found significantly elevated renal calcium

excretion in the absence of any change in plasma calcium level during acid exposure and indicated the possible involvement of bone reabsorption. Similarly, Beamish (1972) suggested that deformities seen in white suckers might be due to mobilization of calcium-salts from bones as a buffer against acidemia. Skeletal deformities found in the same population by Beamish *et al.* (1975) and by Fraser and Harvey (1982) in an acidified lake also signify skeletal decalcification, although direct evidence is lacking. However, it has been shown that carapace calcium was reduced by 10% in crayfish, *Procambarus clarki*, exposed to acidic condition, although there were no changes in hemolymph calcium concentrations (see McMahan and Stuart, 1989; quoted from McMahan, B.R. and Stuart, S., unpublished). Wood and Regano (1986) also working on crayfish came to the conclusion that H⁺ ions entering the body are effectively removed from hemolymph either by ionic exchange with tissue (K⁺ involvement) or by dissolution of calcium carbonate of the exoskeleton. Similar decalcification is likely to occur in teleosts (Ruben and Bennet, 1981). Therefore, investigation into the fate of calcium reserves rather than measurement of plasma calcium levels during acid or acid associated metal exposure is necessary.

As far as can be discerned from the literature, the only attempt to explore the possibility of mobilization of calcium reserves in fish in an acidic environment has been made by Rodger (1984). However, he did not observe any effect of acid (pH 5.3) on calcium dynamics in brook trout, *Salvelinus fontinalis*. To clarify the field situation, Rodger (*ibid*) suggested the possible role of elevated trace metals in depletion of calcium reserves. Aluminium is one of the most important trace metals found in elevated levels in acidified waters and its deleterious effects on ionoregulation are well documented (see Chapter 1). To date, the role of aluminium in calcium metabolism and dynamics has not been investigated.

The observed acidification of water bodies is often associated with low concentrations of calcium. The role of calcium in maintaining gill permeability and integrity and its mitigating effects on trace metal toxicity are well recognized (see Chapter 1, 3 & 4). Further, the effects of environmental calcium on calcium dynamics and calcium fluxes have been reported (Perry and Wood, 1985; Flik *et al.*, 1986). Therefore, the relative contribution of calcium, pH and aluminium to apparent anomalies in calcium regulation in fish living in waters of low calcium, low pH and elevated aluminium concentrations would seem to be an appropriate approach to the understanding of calcium metabolism in acid-stressed environments. In the present study, therefore, the calcium pool of various tissues of tilapia were pre-labelled by ^{45}Ca injection and its subsequent distribution and retention was followed over time in neutral, acid and aluminium contaminated acid environments.

6.2. MATERIALS AND METHODS

6.2.1. The Source of Fish and Pre-exposure Acclimation

The fish, *Oreochromis niloticus*, used in this experiment were $12.20 \pm 1.58\text{g}$ in weight. The source and maintenance of the stock was essentially the same as described earlier (Chapter 2). A total of 84 fish, divided into two groups, was acclimated either in LCW (0.6 mg Ca l^{-1}) or HCW (16 mg Ca l^{-1}) water in the Tropical Aquarium, Institute of Aquaculture, under conditions identical to those described in Chapter 2. On day 10 of acclimation in the above facility, the fish were transferred to the Aquarium Suite (constant temperature room), Cottrell Building, University of Stirling and were further acclimated for two days essentially in the same conditions as above.

6.2.2. Prelabelling of Tissue with ^{45}Ca

After acclimation each group of fish was given an intraperitoneal injection of ^{45}Ca (Amersham International; specific activity $9.25\text{-}37.5 \text{ GBq/mol Ca}$) in distilled water at a dosage of $0.5 \mu\text{Ci g}^{-1}$ body weight. The volume of injected fluid was $90\text{-}140 \mu\text{l}$ depending on the weight of the individuals. The fish were then returned to their respective acclimation medium. Six days after tracer injection, six fish from each group were sacrificed. This is referred to as day 0 (initial) sample for the measurement of radioactivity incorporated into the scales, vertebrae and muscle tissue. The injected fish were not fed during this period.

6.2.3. Exposure Protocol

To investigate the effects of pH, calcium and aluminium concentrations, each group of fish was then further divided into three groups. The first group of fish (thereafter called control fish) was maintained at a circumneutral pH (same as respective acclimation medium) and served as control. The second group of fish was exposed to low pH water

of 5.2 (called acid-exposed fish) while the third group was exposed to acid water with a nominal aluminium concentration of $220 \mu\text{g l}^{-1}$ (called acid/aluminium-exposed fish).

Fish were held in 12 l plastic tanks (6 fish/tank). There were two replicate tanks for each of six combinations of pH, calcium and aluminium as mentioned above. The experimental tanks were contained in large plastic holding tanks. Temperature ($27 \pm 1^\circ\text{C}$) was regulated by thermostatically controlled electric heaters and the experimental tanks were aerated with compressed air through perforated air tubes.

The exposure medium was renewed daily. The pH was monitored several times each day and was adjusted as required using 0.1M HNO_3 . Fish were fed on a calcium deficient synthetic feed (Appendix-7) on alternate days until day 16 of exposure and thereafter discontinued, since fish exposed to acid/aluminium in LCW conditions were found to be reluctant to accept the feed.

The experiment was continued for 21 days and the fish were sacrificed (3 fish/tank/sampling) on day 4 and 21 of exposure. The sampled fish were weighed, sealed in small polythene bags and kept frozen until analysis.

Every 3-4 days during the experimental period water samples for total aluminium determination were taken at 7 and 24 h after renewing the exposure media.

6.2.4. Preparation of Tissue Samples for Analysis

Frozen fish were thawed rapidly and blotted dry. Scales were removed from the dorsal side, blotted dry and approximately 30-40 mg were retained for analysis. Muscle samples (150-200mg), carefully freed of bones and scales, were also taken from the dorsal region. Fish, wrapped in polythene bags, were then cooked in a microwave oven

for 20 seconds at a medium power level. A few anterior vertebrae (30-40mg), freed of muscles tissue, were blotted dry and weighed quickly. All samples were placed in acid-washed glass tubes for digestion.

To each sample 0.6 ml concentrated nitric acid was added. Samples were left for 6-10 h at room temperature and then heated to 95°C for 4-5 h in a water bath. Sample volume was then adjusted to 5 ml with double-distilled water and the diluted digestants were stored in polythene vials for analysis.

6.2.5. Counting of Radioactivity

A 1 ml diluted tissue digest was mixed with 4 ml liquid scintillant (Hionic Fuso Fluor, Packard) and counted in a Packard Scintillation Counter equipped with a count per minute (cpm) programme. The counting efficiencies of the samples were found to be 89-94%, 86-91% and 91-96% for scales, muscles and bones, respectively by internal spiking method. The counts were then corrected for background and quenching. The values are expressed as cpm mg⁻¹ wet tissue.

6.2.6. Determination of Total Calcium in Tissue Digest

Total calcium content in prepared tissue digests was determined by the thymol-blue method of Gindler and King (1972). Scale and vertebra digests were diluted 20 times, while muscle tissue digests were used undiluted. Determinations were carried out on 50 µl diluted digests of scales and vertebrae and on 100 µl of muscle tissue digests. Standards were prepared from calcium carbonate in dilute HCl following the methods described by Connerty and Briggs (1966). The standard curve was linear over 14 mg Ca/100 ml. The results are expressed as mmol Ca g⁻¹ wet tissue.

6.2.7. Determination of Aqueous Aluminium

Total aluminium in exposure media was determined according to the spectrophotometric method of Dougan and Wilson (1974). Aluminium references were prepared from an aluminium atomic absorption standard solution (1 mg ml⁻¹; BDH).

6.2.8. Statistical Analysis

Before performing any statistical analysis, normality and homogeneity of the data were checked as described earlier (Chapter 3). If necessary, appropriate transformations of the data were done as before. Groups means within days were tested by one-way analysis of variance. When F-value indicted significant difference, LSD-test was employed to discern specific differences. To test the interaction of exposure aluminium and calcium concentrations (at pH 5.2), two-way analyses of variances were performed. Comparisons between initial and other treatment groups of fish (pair wise) were made by using t-test. Unless otherwise stated significant differences were accepted at $P < 0.05$.

6.3. RESULTS

6.3.1. Aluminium Concentration in the Exposure Media

Exposure media were changed daily throughout the experimental period and aluminium levels were measured 7 or 24 h after media renewal at every 3 or 4 days in order to determine total aluminium levels in the exposure media. The results are presented in Table-6.1. Irrespective of medium calcium concentrations, aluminium concentrations in the exposure media were greatly reduced at both 7 and 24 h after renewal of media. There was no significant difference in total aluminium concentration between low calcium water (LCW) and high calcium water (HCW).

6.3.2. ⁴⁵Ca Retention in Different Tissues

Scales

Initial (day 0, i.e. 6 days after tracer injection) mean radioactivity in scales of tilapia acclimated in LCW conditions (7070 cpm/mg scale) was higher than that in fish acclimated in HCW (5730 cpm/mg scale). The latter was approximately 81% of the former and due to larger variations within groups, the difference in mean radioactivity levels between the above groups of fish was not statistically significant ($P = 0.056$; t-test). (Fig. 6.1a).

On day 4 of exposure, mean radioactivity levels in scales in either LCW or HCW control fish did not differ significantly from their respective initial activity levels. At the termination of the experiment (day 21 of exposure), however, the initial tracer load in scales of LCW control fish reduced by 18% and the difference was found to be statistically significant (Mann-whitney-test). During the same period, however, initial radioactivity levels had fallen (insignificantly) approximately by 7% among the control fish held in HCW. The difference in percent retention of ⁴⁵Ca activity levels between

Table-6.1. Measured aluminium concentrations in the exposure media during a 21 day experimental period. Samples was removed at every 3-4 days, 7 and 24 h after media renewal. The medium was renewed daily. Nominal aluminium concentration was $220 \mu\text{g l}^{-1}$. Values are arithmetic means \pm S. D. (n=10-12). Aluminium concentration in the media without added aluminium was $<1-3 \mu\text{g l}^{-1}$

Calcium concs.	Aluminium concentrations ($\mu\text{g l}^{-1}$)	
	7 h	24 h
0.6 mg l^{-1} (LCW)	140 ± 12	79 ± 9
16.0 mg l^{-1} (HCW)	133 ± 14	74 ± 7

the two groups of control fish was statistically significant (LSD-test) indicating higher tracer loss under LCW conditions (Fig. 6.1a).

Acidic conditions (pH 5.2) seemed to have had little or no effect on ^{45}Ca retention in scales. Both groups of acid-exposed fish either in LCW and HCW conditions did not differ in mean scale radioactivity levels from their respective control fish when determined on either day 4 or day 21 of exposure (Fig.6.1). However, as in control fish, acid-exposed fish also lost substantial amounts (16%) of the initial tracer load by the end of the experiment in LCW conditions compared to a 7% loss recorded for HCW fish.

Retention of incorporated ^{45}Ca in scales of tilapia was significantly affected by acid/aluminium exposure in the low calcium environments (Fig.6.1). After 21 days of exposure, acid/aluminium-exposed fish in LCW conditions retained significantly lower mean radioactivity in scales in comparison with respective control or acid-exposed fish (LSD-test). By contrast, the corresponding group of fish in HCW did not differ significantly in scale radioactivity from the respective control or acid-exposed fish, although radioactivity levels were maintained at a lower level in the former group of fish (Fig.6.1a). Due to higher tracer loss in acid/aluminium-exposed fish in LCW environment, the initial difference in the mean activity between LCW and HCW acid/aluminium-exposed fish in the scale mean radioactivity was greatly reduced. However, the percent retention of initial activity of the two groups of fish differed significantly. Two-way analysis of variance performed on day 21 data of acid and acid/aluminium-exposed fish indicated that the actions of calcium and aluminium on the tracer retention were significant ($P < 0.01$ and $P < 0.05$, respectively) and there was no significant interaction of the two factors.

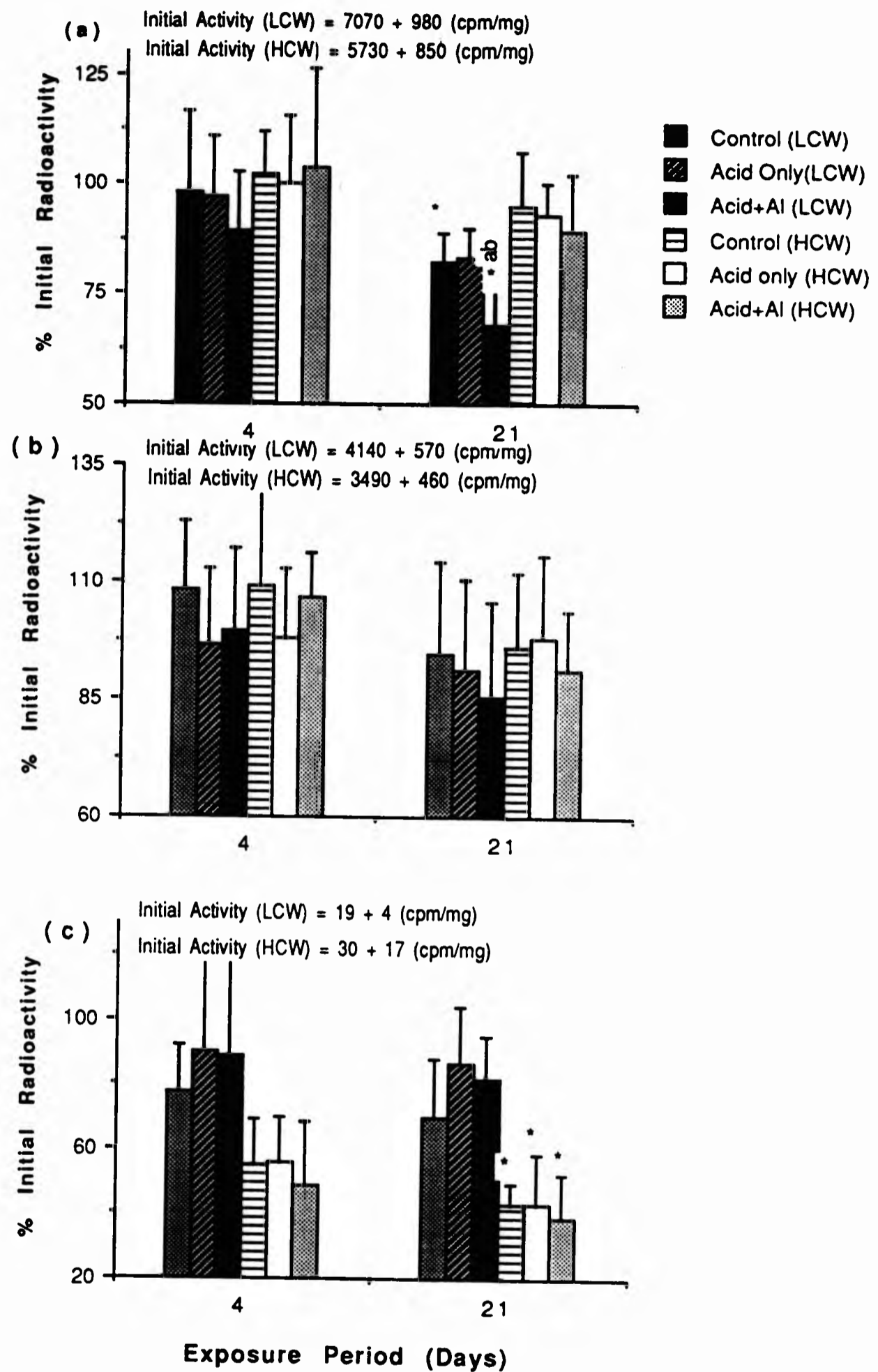

Fig.6.1. Percent changes in ⁴⁵Ca activity in (a) scales (b) vertebra (c) muscle tissue of tilapia exposed to acid and acid/aluminium in LCW and HCW conditions for 21 days. Vertical bars indicate ± S. D. Asterisks indicate significant differences from corresponding groups of fish in LCW or HCW. Letters 'a' and 'b' indicate significant differences from respective control and acid-exposed fish.

Vertebrae

Initial mean radioactivity levels in vertebrae were approximately 4130 cpm/mg and 3490 cpm/mg in LCW and in HCW acclimatized fish, equivalent to approximately 58% and 61%, respectively, of the scale radioactivity levels in the same groups of fish (Fig. 6.1b). Due to some large individual variations, the difference in vertebral mean radioactivity levels between LCW and HCW fish was not statistically significant (t-test). On day 4 of exposure (10 days after tracer injection), vertebrae of both groups of control fish were found to have elevated radiotracer levels. After 21 days exposure, mean radioactivity levels, however, had decreased to 92% and 96% of the respective initial radioactivity in LCW and HCW fish, respectively. These reductions in radioactivity levels, however, also were not significantly different (t-test). Similarly, no significant difference could be detected between the two control groups of fish either on day 4 or day 21 of exposure (LSD-test). Again, the experimental pH did not have any significant influence on the retention of incorporated ^{45}Ca during the experimental period.

Similarly, acid/aluminium exposure also did not affect ^{45}Ca retention in the vertebrae of tilapia (Fig. 6.1b). After 21 days of exposure to acid/aluminium, the mean radioactivity had declined (insignificantly; t-test) to a level of approximately 90% and 93% of the initial radioactivity in LCW and HCW, respectively. When compared with respective control or acid exposed fish, in neither case was the difference significant. Likewise, there was no significant difference between LCW and HCW groups of acid/aluminium-exposed fish in the vertebral radioactivity levels. Two-way analysis of variance revealed no significant action of calcium or aluminium on the percent retention of ^{45}Ca activity in vertebrae and there was no significant interaction of the factors (Fig. 6.1b).

Muscle tissue

Muscle tissue of tilapias acclimated in LCW and HCW accumulated negligible amount of ^{45}Ca (19 ± 4 and 30 ± 17 cpm/mg muscle in LCW and HCW fish, respectively, compared with scales or vertebrae (Fig.6.1c). Retention of incorporated tracer was not significantly affected by acid or acid/aluminium exposure or by exposure duration. However, radioactivity levels in all groups of fish fell somewhat during the course of the experiment. Two-way analysis of variance showed a significant effect of external calcium concentrations on the percent retention of radioactivity ($P < 0.001$).

4.3.3. Total Calcium Content

Table 6.2 presents the data on total calcium content on wet weight basis in three different tissue compartments (i.e. scales, vertebrae and muscles) in tilapia exposed to different experimental conditions during a 21 day exposure.

Scales

On day 4 of exposure (16 days after acclimation in LCW and HCW conditions), LCW control fish had lower (3.35 mmol l^{-1}), albeit insignificant, scale total calcium content than that in HCW control fish (3.64 mmol l^{-1}) (Table-6.2). At the termination of the experiment, however, the differences in total calcium content in scales between the two groups of control fish were found to be statistically significant (LSD-test). There was no significant change in scale calcium content in control groups of fish with exposure time (t-test) suggesting that loss of scale calcium under LCW condition mostly occurred during the acclimation and early exposure period.

Total calcium content in scales of acid-exposed fish maintained either in LCW or HCW did not differ significantly from the respective controls (LSD-test) (Table 6.2) or with exposure duration (t-test). Acid-exposed fish under LCW conditions, however, had lower calcium content (insignificant) in scales than the corresponding group of fish in HCW,

Table-6.2. Mean total calcium content (wet weight basis) in scales, vertebrae and muscle tissues of tilapia exposed to different experimental conditions during a 21 day exposure period. Values are arithmetic means \pm S.D. (n = 5-6). Asterisks indicate significant difference from the corresponding group of fish in HCW conditions. Letters 'a' and 'b' indicate significant differences from the acid and acid/aluminium-exposed fish, respectively.

Exposure conditions			Total calcium content in tissues						
Day	pH	Al concs.	Scales (mmol g ⁻¹)			Vertebrae (mmol g ⁻¹)		Muscles (mmol g ⁻¹ x 10)	
			LCW	HCW	LCW	HCW	LCW	HCW	
4	6.8	0	3.35 \pm 0.21	3.64 \pm 0.29	3.19 \pm 0.28	2.91 \pm 0.38	2.50 \pm 0.69	2.30 \pm 0.52	
			2.98 \pm 0.36*	3.71 \pm 0.27	3.04 \pm 0.19	3.27 \pm 0.26	2.15 \pm 0.46	1.94 \pm 0.58	
			3.12 \pm 0.31	3.47 \pm 0.23	3.09 \pm 0.20	3.14 \pm 0.18	2.69 \pm 0.65	2.26 \pm 0.44	
21	6.8	0	3.17 \pm 0.22*	3.53 \pm 0.19	2.93 \pm 0.34	3.18 \pm 0.15	2.07 \pm 0.68	1.89 \pm 0.59	
			3.04 \pm 0.24*	3.70 \pm 0.27	2.89 \pm 0.19	3.31 \pm 0.39	2.84 \pm 0.82	2.20 \pm 0.55	
			2.76 \pm 0.22a*	3.43 \pm 0.36	2.78 \pm 0.29	3.05 \pm 0.14	2.08 \pm 0.61	2.38 \pm 0.45	

either on 4 or 21 days of exposure.

Unlike the acid-exposed fish, the acid/aluminium-exposed tilapia in LCW had significantly lower scale calcium content ($2.76 \pm 0.22 \text{ mmol g}^{-1}$) than the respective control fish ($3.17 \pm 0.21 \text{ mmol g}^{-1}$) at the conclusion of the experiment (Fig. 6.2) but did not differ significantly from the acid-exposed fish ($3.04 \pm 0.24 \text{ mmol g}^{-1}$) held in LCW for the same period of time (LSD-test). The corresponding group of fish under HCW conditions showed no significant difference in total calcium levels in scales compared with control or acid-exposed fish. However, acid/aluminium-exposed fish in LCW showed significantly lower levels of calcium in scales compared with the corresponding group of fish in HCW on day 21 of exposure (LSD-test).

Vertebrae

Vertebral total calcium content in both LCW and HCW control fish remained unaffected by exposure duration (t-test). The above two groups of fish also did not differ in the total calcium content in vertebrae determined on day 4 and day 21 samples (LSD-test) (Table-6.2). Exposure to acid alone conditions, both in LCW and HCW conditions, also did not cause any significant changes from their respective controls either on day 4 or 21 of exposure.

After 21 days exposure, acid/aluminium-exposed fish in LCW after, however, showed somewhat lower calcium concentrations in vertebrae ($2.78 \pm 0.29 \text{ mmol g}^{-1}$) than controls ($2.93 \pm 0.34 \text{ mmol g}^{-1}$) and the corresponding group of fish held in HCW ($3.05 \pm 0.14 \text{ mmol g}^{-1}$), although in neither case was the difference significant (LSD-test). Two-way ANOVA showed no significant actions or interactions of the factors.

Muscles tissue

Muscle calcium content determined on day 4 samples in LCW and HCW conditions were $2.05 \pm 0.69 \times 10^{-3}$ and $2.30 \pm 0.52 \times 10^{-3}$ mmol g⁻¹ tissue, respectively, and were unaffected by calcium and aluminium concentrations in the media (ANOVA-test) and duration of exposure.

6.4. DISCUSSION

6.4.1. Aluminium Concentrations in the Exposure Media

A great proportion of nominal aluminium concentration from the exposure medium was reduced either 7 or 21 h after renewal of the medium (Table-6.1). Loss of aluminium from exposure media was also reported in static exposure studies by Dalziel *et al.* (1986) and in flow-through experiments by Dalziel *et al.* (1987). Surprisingly, near nominal concentrations of aluminium were achieved in static experiment by Karlsson-Norrgrén *et al.* (1986b) where media was changed on a weekly basis. The latter authors (Karlsson-Norrgrén *et al.*) used tap water and unfortunately, background levels of aluminium were not reported. In the former two studies (Dalziel *et al.*) loss of aluminium from the medium was mainly assumed to be the result of solubility of aluminium at a particular pH and was also partly attributed to adsorption on to the surface of fish and fish holding tanks. A similar explanation is probably applicable in the present study.

In the present study, the fraction of aluminium remaining in the medium after 7 h of exposure ranged approximately between 63% and 61% (in LCW and HCW, respectively) of the nominal concentrations at pH 5.2 and appears comparatively higher than expected from Dalziel *et al.*'s (1986) results. However, in the present study fish weight/medium volume, medium volume/tank surface area ratios were higher than those in Dalziel's experiment. Furthermore, continuous exposure of the same group of fish over a longer period of time (21 d) in the present study would probably have minimized the effects of adsorption. Although total aluminium concentrations were measured twice daily, it is still difficult to predict the precise level of aluminium in the media that influenced the results of the present study.

6.4.2. Effect of Exposure Calcium Concentrations

Six days after intraperitoneal administration of ^{45}Ca , the scales of fish in LCW retained higher radioactivity than fish held in HCW. Similarly, fish vertebrae accumulated higher ^{45}Ca in low calcium environment, although the differences were not statistically significant. Rosenthal (1956) studied the incorporation of ^{45}Ca in the guppy, *Lebistes* sp. over a wide range of calcium concentrations (16-800 ppm) and found that maximum uptake and accumulation from the environment occurred at lowest external calcium ion concentrations. Similarly, tracer injection experiments by Flik *et al.* (1986) have shown that approximately four days after injection the relative specific activities were higher in tilapia, *O. mossambicus*, kept in LCW (0.2 mmol l^{-1}) than in fish maintained in HCW (0.8 mmol l^{-1}). Similar observations have also been made by Mashiko *et al.* (1964) who noted highest ^{45}Ca activity in scales of crucian carp, *Carassius auratus*, kept in low calcium water five days after tracer injection. While the mechanism remains unexplained for the differential tracer accumulation, the latter authors concluded that the bone-seeking ability of calcium increases in low calcium environments. This is substantiated by the fact that the readily exchangeable calcium pool in total bone compartment increases in low environmental calcium conditions, indicative of highly efficient exchange of calcium between blood and tissue (Flik *et al.*, 1986). Another possible explanation for higher ^{45}Ca accumulation in low calcium conditions is that fish already acclimated in LCW may have mobilized at least part of their calcium reserves and, therefore, injected ^{45}Ca is taken up in those exhausted pools on a priority basis. Indeed, depletion in total calcium content in tilapia *O. mossambicus*, scales during acclimation in low calcium water was previously observed by Wendelaar Bonga and Flik (1982). In the present study, scales (significantly) as well as vertebrae (insignificantly) of tilapia in LCW condition lost incorporated ^{45}Ca faster than fish held in HCW (Fig. 6.1 & 6. 2; Table-6.2). The results are in agreement with those of Flik *et al.* (1986) who also found rapid tracer loss in low calcium conditions. These authors

also recorded higher influx as well as higher efflux rates in the same group of fish. The higher flux rates in fish, together with increased exchangeable calcium pool in tissue compartment in LCW conditions, might have resulted in dilution of incorporated tracer, thereby contributing to the apparent higher rate of calcium turnover.

The present observations on higher tracer loss in LCW fish contradicts the findings of Mashiko *et al.* (1964) who recorded lower rates of tracer loss in scales of crucian carp held in low calcium water conditions. However, in the above study the lowest calcium concentration used (10 mg l^{-1}) was much more higher than was used in the present study (0.6 mg l^{-1}). At such high ambient calcium concentrations (in the study of Mashiko *et al.*), the flux rates may not change, resulting in lower turnover of tracer. However, further data is needed to substantiate this point.

Similarly, the total calcium content in scales of tilapia was significantly reduced in LCW fish. Although no significant differences were found in the vertebral calcium content, the level was found to be slightly depressed. Previous studies by Flik *et al.* (1986) have shown significant depletion in scale calcium content in tilapia maintained in a low calcium environment for a period of 10 weeks. Flik *et al.* (*ibid*) also recorded a significant decrease in vertebral total calcium content, apparently contradicting results from the present study, despite the fact that much lower medium calcium concentrations were used here. However, although employing lower calcium concentrations (5 mg l^{-1}) than those of Flik *et al.* (8 mg l^{-1}), Rodger (1984) was also unable to demonstrate any significant changes in vertebral calcium content in white suckers during a 9 week acclimation period, thus supporting the present results. Although vertebral calcium content was also found to be insignificantly depressed in LCW fish in the present study, it may be that significant differences only become apparent with longer exposure. As mentioned in the previous Section (6.3.3.), the loss of scale total calcium probably

occurred during the acclimation and the early period of exposure. Indeed, Wendelaar Bonga and Flik (1982) found similar trends in bone reabsorption in tilapia and concluded that it might have occurred during the first two weeks after transference to low calcium water.

Results showed that scale radioactivity decreased significantly with exposure time in LCW fish without significant changes in scale total calcium (Table-6.2 & 6.3.), suggesting higher turnover of calcium in low calcium environment (i.e. higher rates of uptake and loss).

6.4.3. Effect of pH

Neither LCW or HCW acidic pH (5.2) used in this experiment affected ^{45}Ca dynamics or total calcium content of scales or vertebrae of tilapia during the experimental period. These results are in agreement with those of Rodger (1984) who also did not find any significant changes either in ^{45}Ca dynamics or in total calcium content between brook trout held at low pH condition (5.3) and control fish maintained at pH 6.8. Wendelaar Bonga *et al.* (1987) reported only a transient decrease in scale and vertebral calcium content in tilapia. However, in their studies the experimental pH was 4.0.

Contradictory results also exist on calcium metabolism in fish during acid exposure. Reader *et al.* (1988; 1989) found impaired whole body net uptake of calcium in yolk-sac fry of brown trout exposed to low pH. Malley (1980) made similar observations in crayfish. Nelson (1982) found impaired ossification in fish exposed to acidic water. However, the above results do not necessarily conflict with the present results since the exposure pH in the above studies ranged between 4.4 and 4.8 which is considerably lower than those used in the present study. Furthermore, interspecies differences also exist. In fact, tilapia are considered a resistant species with considerable adaptive ability

in acidic environment (Wendelaar Bonga *et. al.*, 1984a; Wendelaar Bonga, 1984b; Wendelaar Bonga and Balm, 1989).

The absence of effects of low pH on calcium dynamics seems contrary to field reports of reduced calcium concentrations in vertebrae of white suckers caught in a lake with pH-value comparable to the present study (Harvey and Fraser, 1982). However, that may be an artifact of elevated metal concentrations, since in the field, elevated concentrations of metals are associated with acid water (Spry *et.al.*, 1981). Use of synthetic water in this study has probably excluded the possibility of metal-induced stress effects.

6.4.4. Effect of Aluminium Concentration

This investigation has clearly demonstrated the adverse effects of acid/Al exposure in depleting calcium reserves in scales under low calcium condition. Impairment in whole body net calcium uptake in brown trout yolk-sac fry under acid/aluminium exposure conditions (pH 4.5 and 5.4; Al 2-8 $\mu\text{mol l}^{-1}$) has been reported by Reader *et al.* (1988; 1989). In those studies the fry grew over a period of time and in general had a net uptake of calcium, although the rate of uptake was probably lower than among control fry. In the present study, during 21 days exposure to acid/aluminium in LCW, the mean radioactivity levels in scales decreased significantly compared with control fish. Concomitant reductions in scale total calcium content suggest that the loss of radioactivity was not merely an artifact of higher turnover but was due to a net loss of calcium from scales. Loss in scale calcium is probably the result of impairment in calcium flux rates where efflux must be greater than influx. However, the effects of aluminium on calcium regulation in fish is debatable. Aluminium levels 6 $\mu\text{mol l}^{-1}$ (160 $\mu\text{g l}^{-1}$) did not affect flux rates (there was only an insignificant increase in efflux) in brown trout fry (Reader and Morris, 1988) under experimental conditions more or

less similar to the present study. However, such concentrations under identical exposure conditions did affect whole body net calcium uptake in brown trout fry (Reader *et al.*, 1988). In a separate study, in comparable exposure conditions (but in through-flow system), in general, the present author found decreased Ca^{2+} -ATPase activity in tilapia gills (Chapter 5). As discussed in Chapter 1, 3 & 8, aluminium is known to increase gill permeability leading to increased efflux and at the same time inhibition in Ca^{2+} -ATPase activity, probably resulting in a net loss of ions. Aluminium also enhances the passive influx of H^+ ions and causes respiratory and metabolic acidosis (see Chapter 1, Section 1.4.). The resulting acidemia or internal acidosis may lead to the titration of skeletal Ca-salts as buffer in addition to intracellular buffering by alkali reserves (Wood and Regano, 1986; Beamish, 1972; Rubben and Bennet, 1981) and titrated calcium may be excreted along with urine (McDonald and Wood, 1981). Therefore, like other electrolytes (e.g. Na^+ , Cl^-) plasma calcium level may fall. Since teleosts can maintain normal plasma calcium concentrations under diverse environmental conditions (Flik *et al.* 1986, Fenwick and Bonga, 1982, Payan *et al.*, 1981) and skeletal calcium is known to help compensate for such loss of plasma calcium ions (Pang *et al.*, 1971; Flemming, 1974), as it does during maintenance in low calcium conditions (Flik *et al.*, 1986), the changes in plasma calcium levels do not become apparent, although body calcium reserves are depleted during the same period.

The mechanism by which scale calcium is reabsorbed in teleosts is poorly understood. In higher vertebrates the reabsorption of bone calcium is under the control of parathormone (Simmons, 1971; Dacke, 1979). This hormone either seems to be absent in fish or its homologue has not yet been identified. Calcitonin (secreted from ultimobranchial body of fish) which controls calcium deposition in bones of fish probably has no role in bone reabsorption (Lopez *et al.*, 1975; Dacke, 1979). However,

the possibility of involvement of such a hormone can not be discounted. Since fish skeleton is highly vascularized (particularly in scales) and the skeletal calcium may be considered as exchangeable with extracellular calcium pools, Moss (1963) and Flik *et al.* (1986) have suggested that these processes in fish may be accomplished by simple physico-chemical exchange process under normal conditions and even under acalcemic conditions.

It is evident from the results that external calcium concentrations reduced acid/aluminium-induced tracer (^{45}Ca) and total calcium loss. This effect of external calcium is consistent with the protection afforded by external calcium on other plasma and tissue ion levels. The basis of the protective effect is discussed in detail in Chapter 1 & 8.

6.4.5. Total Calcium Concentrations and ^{45}Ca Dynamics in Different Tissue Compartments.

In the present study total calcium concentrations in different tissues were determined on a wet weight basis. Although this may have been misleading when comparisons are made with other works, in practice, it does not appear to create any problems. In a preliminary investigation, total calcium content in scales, vertebrae and muscle tissue in tilapia were determined on a dry weight basis as well as on the basis of wet weight. The pretreatment of samples was essentially the same as in the present study. When converted on the basis of wet weight and dry weight ratios, both methods yielded approximately the same results. The observed total calcium concentrations in different tissues (after conversion to dry weight) compare favourably with those reported by Flik *et al.* (1986), and by Wendelaar Bonga and Lammers, (1982) for tilapia.

The differences in calcium dynamics among the three tissue compartments reflect

1472

differences in physiological and metabolic functions of calcium in those tissues. Scales are well vascularized and on a weight basis have a greater calcium uptake capacity and higher turnover rate than endodermal bone, particularly acellular type (Dacke, 1979). Tilapia bone is considered an acellular type (Moss, 1963). Thus the higher accumulation and rapid loss of radiotracer and significant changes in total calcium content are explicable. Acellular bone is known to be metabolically less active and undergoes little remodelling (Simmons, 1971; Simkiss, 1974). However, minerals can be withdrawn from teleost acellular vertebrae, albeit at very slow rates (Flemming, 1976). The conservative behaviour of calcium in vertebrae was confirmed in the present study in which neither ambient pH, aluminium nor calcium significantly affected calcium dynamics or total calcium content in tilapia vertebrae during the experimental period. This finding, however, does not necessarily deny the possibility of vertebral reabsorption, which might have occurred but at a rate that would only be apparent over a longer exposure time. Vertebral calcium can also be reabsorbed when scale calcium is not available. Evidence comes from two studies. Mugyia and Watabe (1977) found the mobilization of scale calcium following oestrogen treatment in killifish, *Fundulus heteroclitus*, although in a subsequent study on killifish Weiss and Watabe (1978) observed vertebral calcium mobilization after removal of scales during regeneration of the latter in the same fish.

Uptake of ^{45}Ca in muscle tissue was negligible (Fig.6.3) and this may be connected with the very low concentrations of total calcium present (Table-6.3). Muscle tissue total calcium content and retention of incorporated ^{45}Ca were not influenced by exposure conditions or exposure duration. The latter seems to contradict the findings of Rosenthal (1956) and Flemming(1973). They estimated a half-life of ^{45}Ca clearance from muscle tissue of guppy between 4 and 5 days. In the present study, loss of large amounts tracer from scales and vertebrae may have masked the actual changes in tracer levels

in muscle tissue.

In summary the following main conclusions can be drawn from the present study:

- (1) Low ambient calcium concentrations significantly increased turnover of scale calcium and simultaneously reduced total scale calcium content in the same compartment;
- (2) pH did not exert any additional influence over the effect of low calcium alone;
- (3) Acid/aluminium exposure in low calcium environments significantly reduced scale calcium levels over and above the effect of low calcium itself;
- (4) No significant changes could be detected in vertebral total calcium content or ^{45}Ca retention under any of the experimental conditions;
- (5) High calcium concentrations in water afforded protective action against the deleterious effect observed in low calcium environment.

CHAPTER 7
EFFECTS OF ACID/ALUMINIUM EXPOSURE ON THE GILL
HISTOPATHOLOGY OF TILAPIA, *OREOCHROMIS NILOTICUS*.

7.1. INTRODUCTION

It was indicated in Chapter 1 that physiological and histological information is needed to understand the mechanism of toxic mode of aluminium. The main physiological problems observed in fish exposed to low pH and elevated aluminium are ionoregulatory and respiratory dysfunction, and acid-base imbalance (see Chapter 1). Given the vital ionoregulatory (Evans, 1980), respiratory (Hughes, 1972; Hughes and Morgan, 1973) and acid-base regulatory (Haswell *et al.*, 1980) functions of the gills, it is logically the tissue to examine for pathological changes. In fact, gills are among the most delicate organ of the teleost body, and their vulnerability and liability to damage due to external irritants is thus greater due to the fact that they are in compulsory contact with the surrounding medium (Roberts, 1978).

Although, there have been few studies on toxicological effects of aluminium on fish gills (see Chapter 1, Section 1.4.2.), most are fragmentary in the sense that they were mainly concerned with limited types of gill lesion. Much of the histopathology associated with acid/aluminium exposure is again based on light microscopical investigations and the lesions were often described as hyperplasia, hypertrophy, increase in lamellar thickness etc. The specific cell types involved have not been identified or differentiated in detail. Although a few studies (Karlsson-Norrgrén, 1986b; Evans *et al.*, 1988; Tietge *et al.*, 1988) have reported proliferative changes in chloride cells numbers, changes in morphology have not been properly evaluated. Excess mucus secretion has been described as the characteristic reaction to acid/aluminium exposure. However, nothing is known about the changes in mucous cells in gill tissue. Although a few studies (Karlsson-Norrgrén *et al.*, 1986b; Youson and Neville, 1987; Jagoe *et al.*, 1987) took advantage of the high resolution capabilities of transmission electron microscopy, still little is known on the ultrastructural changes in the branchial cells

involved in the pathological processes. As a result a complete picture does not exist on the histopathological effects of aluminium on fish gills.

The previous experiments described (Chapters 3 to 6) and a number of other studies (Chapter 1, Section 1.4.1.2) have demonstrated the mitigating effects of external calcium concentrations on the ionoregulatory imbalance in fish during acid/aluminium exposure. Since external calcium influences cellular stability (see Chapter 1, Section 1.6)), it is likely that the susceptibility of gill tissue to external irritant may also depend on the concentrations of calcium of the exposure medium (see McDonald *et al.*, 1983). Evans *et al* (1988), using natural waters from two lakes differing in their hardness components, demonstrated that as much as twice the aluminium was necessary to elicit the same effect in gills of rainbow trout under hard than soft water conditions and indicated the importance of external calcium in the protection of gill damage caused by aluminium. Unfortunately, no further work was done into the effects of external calcium concentrations on the acid/aluminium- induced changes in gill structure and ultrastructure under controlled laboratory conditions. This clearly remained an interesting area to investigate.

Detailed histopathological studies of gill tissue are thus necessary to understand the toxic effects of aluminium in fish. The aim of this study was to qualitatively examine changes in structure and ultrastructure of tilapia gills during both short-term and chronic exposures to different aluminium and calcium concentrations as they relate to the physiological problems observed during acid/aluminium stress in order to determine whether cell composition in the primary and secondary lamellae and cell morphological characteristics change in response to exposure to aluminium, calcium and exposure duration.

7.2. MATERIALS AND METHODS

7.2.1. The Source of Material and Tissue Sampling

Gill material was obtained from the fish used for blood collection during investigations on blood parameters (Chapter 3-Experiment Series 3; Chapter 4 -Experiment 1 & 2). The experimental protocols are detailed in the appropriate chapters. However, for convenience, it will be reiterated here that in the former case (Chapter 3 -Experiment Series 3), fish were exposed for 4 days to different aluminium concentrations (0-520 $\mu\text{g Al l}^{-1}$) and two calcium concentrations (0.015 and 0.400 mmol l^{-1}). However, gill samples were collected from control, 0, 120, 220 and 320 $\mu\text{g Al l}^{-1}$ treatment groups of fish during both LCW and HCW experiments. In addition, a further group of fish exposed to 520 $\mu\text{g Al l}^{-1}$ under HCW conditions was also sampled. Fish were sampled at the end of the experiment. In the latter case (Chapter 4, Experiment 1 & 2), in separate studies, fish were exposed to different aluminium concentrations (0, 50, 100 and 150 $\mu\text{g l}^{-1}$) under LCW or HCW conditions for 21 days. Samples were taken at day 2, 9 and 21 of exposure. An initial sample was also taken on day 0, just prior to acidification of the experimental water (designated as zero (0) day sample).

Immediately after blood sampling the blood supply to the head was severed immediately behind the operculae in order to minimize the risk of blood spilling and adhering to the surface of the filamental and lamellar epithelia, thus facilitating clear observation of the epithelial surfaces, especially under scanning electron microscope. For consistency, the second, third and fourth right holobranchs were dissected out using fine scissors and fine pointed forceps, care being taken to avoid the touching gill filaments. For electron microscopy, central portion of the second holobranch was selected. For light microscopy the third, fourth and the remainder of the second holobranch were used. The gill tissues were then immediately fixed in appropriate fixative solutions (see

below).

7.2.2. Light Microscopy

Tissue fixation

For light microscopic histological investigations gill tissues were fixed in 10% phosphate-buffered formalin and left for at least one week before further processing.

Tissue processing

Fixed tissues were cut into suitable pieces, cassetted, labelled and autoproccessed on a autoprocessor (Histokinette 2000). This involved passing the tissues through different alcohol grades, followed by chloroform and then impregnation in molten wax at 60°C. A detailed processing schedule is given in appendix-3. Processed tissues were then blocked in suitable moulds with molten wax and allowed to cool on a cool plate.

Sectioning and slide preparation

The blocks were trimmed in order to bring the tissue to the surface of the block, and if necessary, decalcified with a rapid surface decalcifier (RDC-Histolab). The blocks were then washed and cooled on a cooling plate prior to sectioning. Serial sections of 4-5 μm thickness were cut on a Leitz-Wetzlar microtome using Richert-Jung disposable microtome blades. Sections were allowed to float on a water bath maintained at 40°C and were collected on pre-washed wet glass slides. The slides were then marked and dried initially on a hot plate for 2 h and then overnight in a oven.

Staining

For general observation sections were stained with haematoxylin and eosin (H & E). The staining schedule is provided in Appendix-4. Special stains such as alcian blue (AB) and periodic-acid and Schiff's (PAS) were also carried out to demonstrate the

mucous cell activity. Procedures and techniques followed were as outlined by Drury and Wallington (1980). Further, detailed schedules are provided in Appendices-5 & 6.

Observation and photomicrography

Stained tissue sections were generally observed under an Olympus compound microscope and photomicrographs from representative histological sections were taken on BHS-10AD automatic photomicroscope. For all black and white photography Ilford Pan F-135 film was used while for colour prints Kodak Ectachrome film was used.

7.2.3. Electron Microscopy

Tissue fixation

The selected portions of the second holobranch were fixed immediately in ice-cold 2.5% gluteraldehyde in 0.2M cacodylate buffer. This fixation took place for 2 h at room temperature, and was followed by overnight washing in the above buffer (3 changes) at 4°C. The tissue was then post-fixed in 1% osmium tetroxide in cacodylate buffer for 1.5 h. The tissues were then given two washes, 15 min each, in the above buffer and passed through 50 and 70% alcohol. At this stage of dehydration tissue samples were sub-divided into two groups; one for scanning electron microscopy (SEM) and one for transmission electron microscopy (TEM) studies. Tissues were stored (not more than 3-4 days) in case further processing had to be delayed as recommended (Hyat, 1978).

7.2.3.1. Scanning Electron Microscopy (SEM)

Gill samples designated for SEM studies were transferred from 70% alcohol to 70% acetone and were further passed through 90 and 100% acetone (2 changes in each grade for 30 min each). Acetone here serves as an intermediate fluid while taking the tissues to critical point drying using liquid carbon-dioxide as transitional fluid. The tissue samples were then critical point dried in a Polaron E-300 critical point dryer, mounted

on aluminium stubs using colloidal graphite paste. Finally, mounted gill tissues were coated with gold-palladium in a sputter coater (Edwards S-150) and examined under a scanning electron microscope (ISI-60A).

7.2.3.2. Transmission Electron Microscopy (TEM)

Gill tissue to be processed for TEM were passed through graded alcohol series for complete dehydration. Dehydrated tissues were further passed through graded alcohol and propylene oxide mixtures. Tissue samples were then taken into Epon medium hard resin (TAAB) through different grades of propylene oxide and resin mixtures. After overnight impregnation in fresh resin at room temperature (usually in a shaker) and then at 37°C for 2 h, tissue were embedded in the moulds using fresh resin and allowed to harden at 60°C for 16-20 h.

Tissue blocks were trimmed and 2 µm thin sections were cut on a LKB paramatome using glass knives. These sections were warmed in a drop of water on a glass slide in order to facilitate flattening and drying and were stained with 1% toluidine blue for examination under light microscope. Ultra-thin sections of selected tissue areas were then cut on a LKB iii ultratome in the gold colour region using glass knives. Sections were mounted on coated copper grids and were double stained with uranyl acetate and lead citrate. Stained sections were then examined under JEOL electron microscope. Representative areas were then photographed. For staining procedures, see Glauert (1975) and Hyat (1978).

7.3. RESULTS

The results presented here are based on qualitative observations made on histological preparations of gill tissue; augmented by scanning and transmission electron microscopy. The results revealed the deleterious effects of aluminium on gill structure and ultrastructure and in general, indicated that the conditions deteriorated with increasing aluminium concentrations and exposure duration. The exact degree of changes, however, in gill tissue varied considerably between filaments and between fish exposed to the same treatment. Most of the photographs produced in this thesis are those judged to be representative of the majority of the filament. However, some of the photographs were taken from areas chosen to demonstrate the particular types of pathology present.

The gill morphology of stock fish is similar to that previously reported for other tilapias such as *O. mossambicus* (Fischelson, 1980; Hocut and Tinley, 1985). In brief, each gill arch bears two rows of gill filaments (primary lamellae) with equally spaced secondary lamellae (Plate 1). The primary epithelium comprises of a stratified squamous epithelium of several layers thick. The surface epithelial cells formed an even cell sheet and were connected to one another by junctional complexes (Plate 2.b). There also occur scattered cells of two special types: chloride cells and mucous cells in the primary lamellar epithelium. Both types of cells are most abundant in the inter-lamellar crypt on the primary lamellae. Mucous cells are also well developed and abundant at the primary lamellar tips. The apical plasma membrane of the epithelial cells is folded into elevated structures, called microridges. Microridges are well defined on the primary lamella and arranged in a concentric manner (Plates 2.b & 3.b)

Both the upper and lower ends of the primary lamellae are folded into a series of flattened, leaf-like structure, called secondary lamellae which form the principal

Plate 1.

Photomicrograph showing the longitudinal section of primary lamellae

(a) From a stock fish

Note that the secondary lamellae are equally spaced and no sign of fusion. Secondary lamellar epithelium is thin and flat (H & E, 375).

(b) From a low calcium water (LCW) acclimated fish

Note the secondary lamellae are slightly swollen and the presence of chloride cells on the secondary lamellae (arrow) (H & E, 375).

a

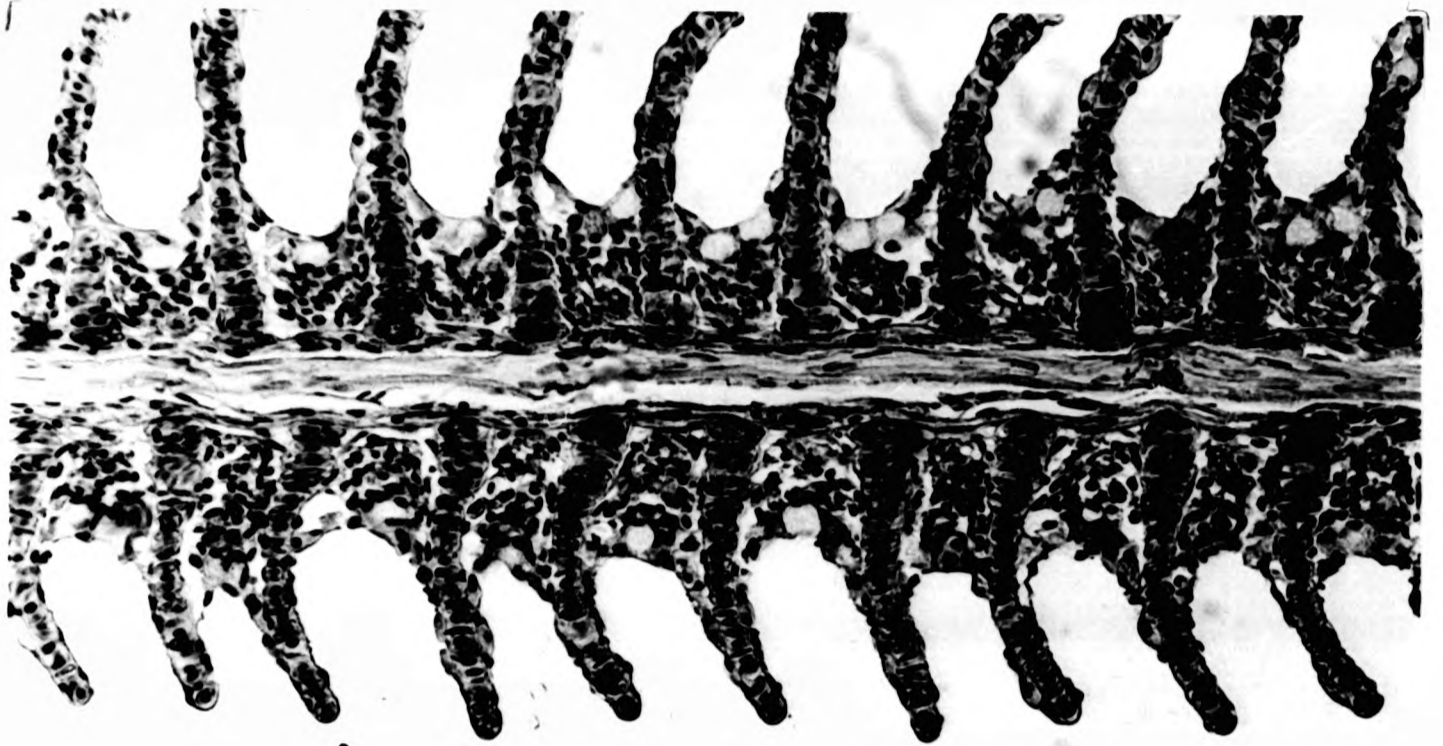

b

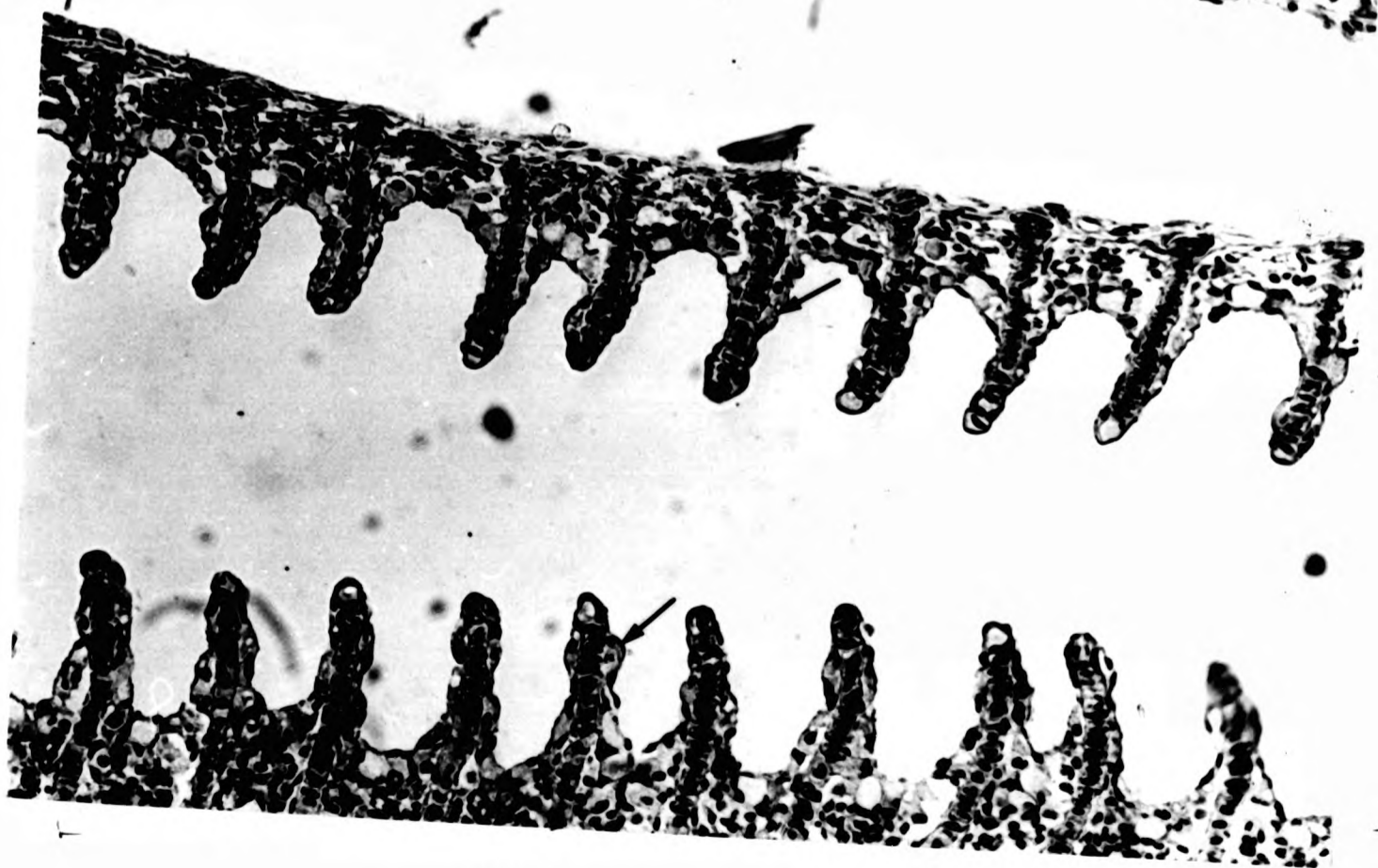

Plate 2

Photomicrograph showing the ultrastructure of gills from stock fish

(a) TEM of secondary lamellae

Note the epithelial cell is flat (epc) long and thin, pillar cell (pc) and capillary network is intact, and intercellular space is small (3300 X).

(b) SEM of primary lamellar surface epithelium

Note the characteristic microridge pattern (arrowhead) and epithelial cell junctional complexes (arrow) (5540 X)

2

a



b



Plate 3

Photomicrograph of surface structure of LCW acclimated gills

(a) Secondary lamellae

Note the normal secondary lamellar microridge pattern, microridges are partly concealed by surface mucus (1850 X)

(b) Primary lamellae

Note the normal microridge pattern (1650 X)

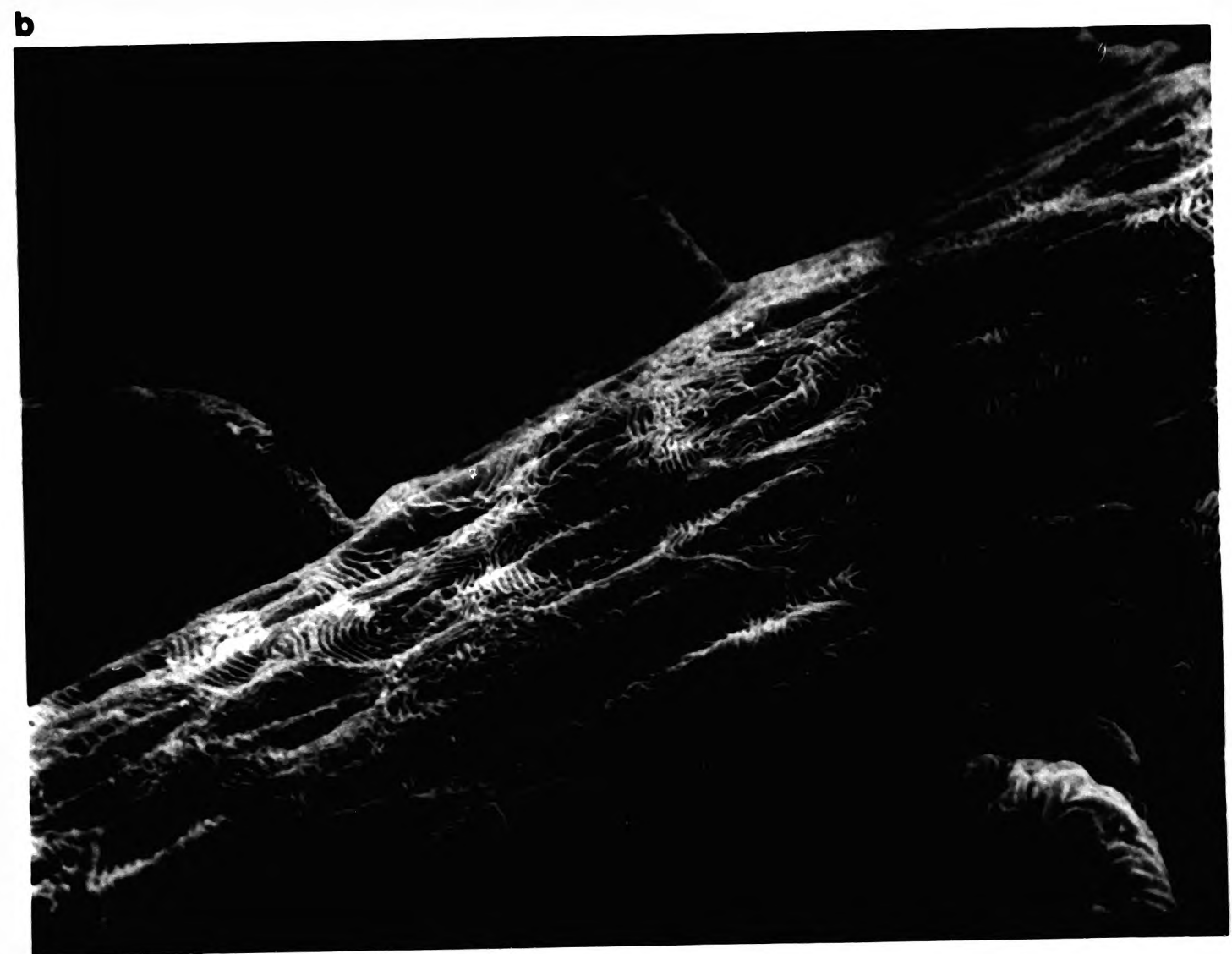
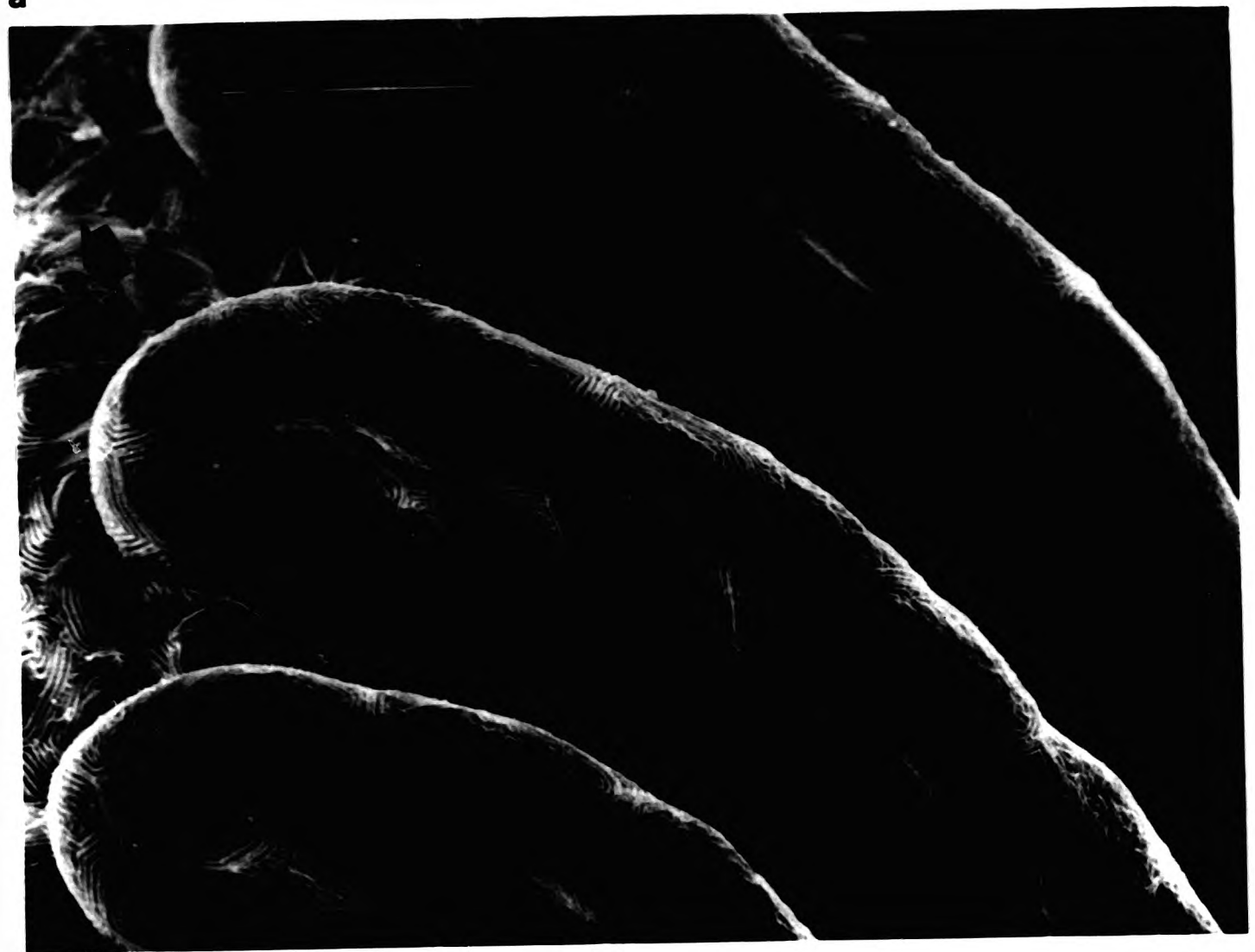

respiratory surface (Plates 3.a & 4.a). Each secondary lamella consists of an external epithelial layer of long, flat respiratory cells (epithelial cells) held apart by rows of supporting pillar cells with blood spaces between. In between the pillar cells and epithelial cells lies a double-layered basement membrane (Plate 2.a). The pillar cells send out thin flanges and several flanges from different pillar cells meet together to form the blood channels. There also occur microridges on the secondary lamellar epithelium but pattern differed from those on the primary lamellae. Microridges on the secondary lamella remain partly concealed by a thin mucous layer (Plate 3.a). Chloride and mucous cells are generally absent from the secondary lamellar epithelium.

The gill morphology of HCW acclimated fish appeared normal. Light and electron microscopy revealed no structural and ultrastructural changes when compared with the stock fish. By contrast, fish acclimated to LCW conditions showed a slight but distinct swellings of both primary and secondary lamellae as could be seen from histological preparations. Transmission electron microscopy (TEM) revealed a mild proliferation in chloride cell numbers and their presence in the secondary lamellar epithelium. Further, both chloride and mucous cells appeared to be slightly hypertrophied. The other structural and ultrastructural features of LCW acclimated gills were similar to that of HCW acclimated fish or stock fish (Plate 1.b)

7.2.1. Chronic Exposure Experiments

(a) Control fish (at pH 5.2 without added aluminium)

The gill structure of control tilapia in HCW experiments as observed histologically was normal, displaying normal primary and secondary lamellar layout as described for stock and HCW acclimated fish, such as equally spaced secondary lamellae with intact cellular integrity and no fusion between adjacent lamellae (Plate 8.b). Surface ultrastructure and cellular organelle were also unaffected.

Plate 4

Photomicrograph showing the surface structure of gills exposed to low pH (5.2) in LCW

(a) SEM of primary lamellae displaying normal secondary lamellar layout

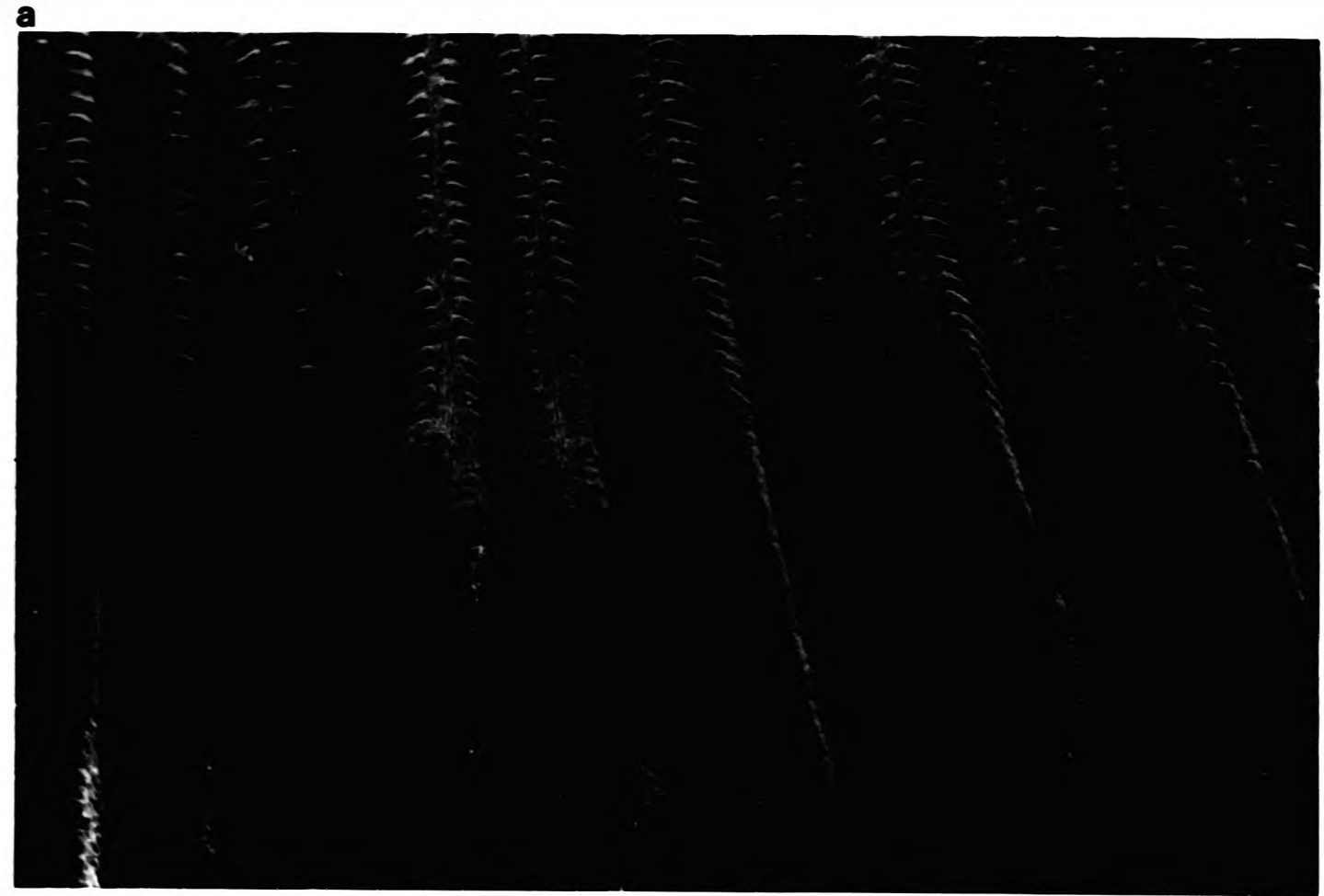

(b) SEM of primary lamellar surface epithelium

Note the normal microridge pattern and appearance of apical pit (arrow) and note also a thin surface mucus film (3050 X)



After 2 and 9 days of exposure, the control fish in LCW experiment showed no noticeable changes. However, by day 21 of exposure, both primary and secondary lamellae appeared slightly swollen, although proliferation of chloride or mucous cells was not conspicuous. However, cellular activity, particularly that of mucous cells, was obvious (Plate 4 & 5.b). The other aspects of gill morphology were similar to that described for LCW acclimated gills.

(b) At 50 $\mu\text{g Al l}^{-1}$

After 2, 9 and 21 days of exposure, the gill morphology of this group of fish under HCW conditions showed no noticeable changes, except that a thin layer of mucus was clearly seen on gill surface and the surface epithelium appeared to be slightly shrunken. Otherwise the gill showed normal features as described for HCW acclimated fish.

Exposure to 50 $\mu\text{g Al}^{-1}$ for 2 or 9 days under LCW conditions also did not cause any noticeable changes in gill structure. However, a marked swellings and mucus clogging of the secondary lamellae were observed after 21 days of exposure (5.a). Compared with control gills an increase in the number of chloride and mucous cells was evident and many of them were present in the secondary lamellar epithelium. While chloride cell hypertrophy was not a major observation, mucous cell hypertrophy was clearly noticeable in the histological sections. Cellular integrity and surface morphology were intact. A thin mucous layer was evident on the epithelial surface (7.a). Hyperplasia or epithelial cell hypertrophy were absent.

(c) At 100 $\mu\text{g Al l}^{-1}$

Fish exposed to this level of aluminium under HCW conditions showed a mild swelling of secondary lamellae after 9 days of exposure and increased further by day 21. This was due to proliferation and hypertrophy of chloride (Plate 16.a) and mucous cells.

Plate 5

Photomicrographs showing the pathological changes in gills following exposure to acid and acid/aluminium in LCW conditions

(a) Fish exposed to $50 \mu\text{g Al l}^{-1}$ for 21 days.

Note swollen secondary lamellae and note also mucus clogging of secondary lamellae

(H & E, 600 X)



(b) Fish exposed to low pH alone for 21 days

Note a mild swelling of secondary lamellae with no sign of fusion (H & E, 600 X)

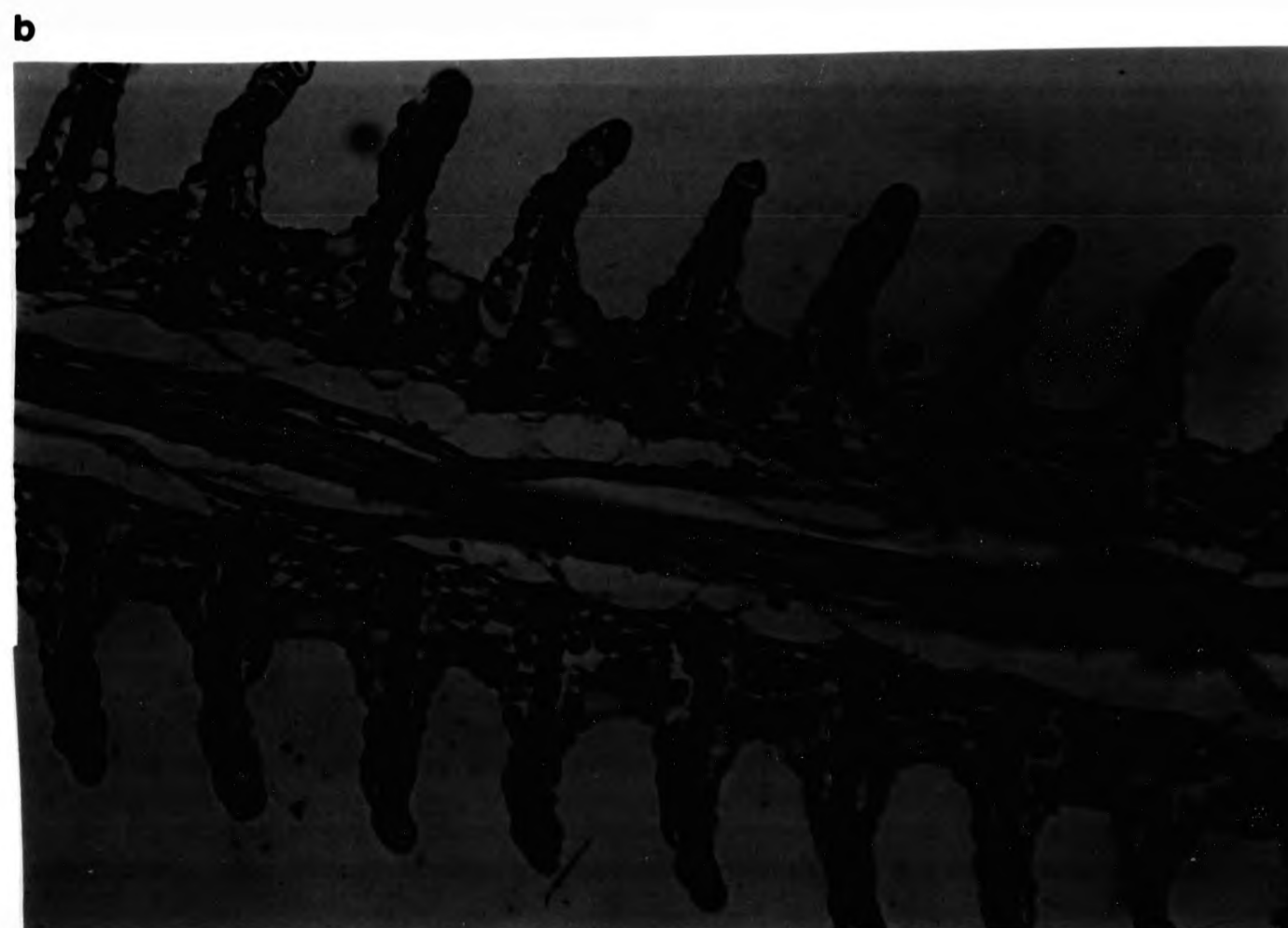
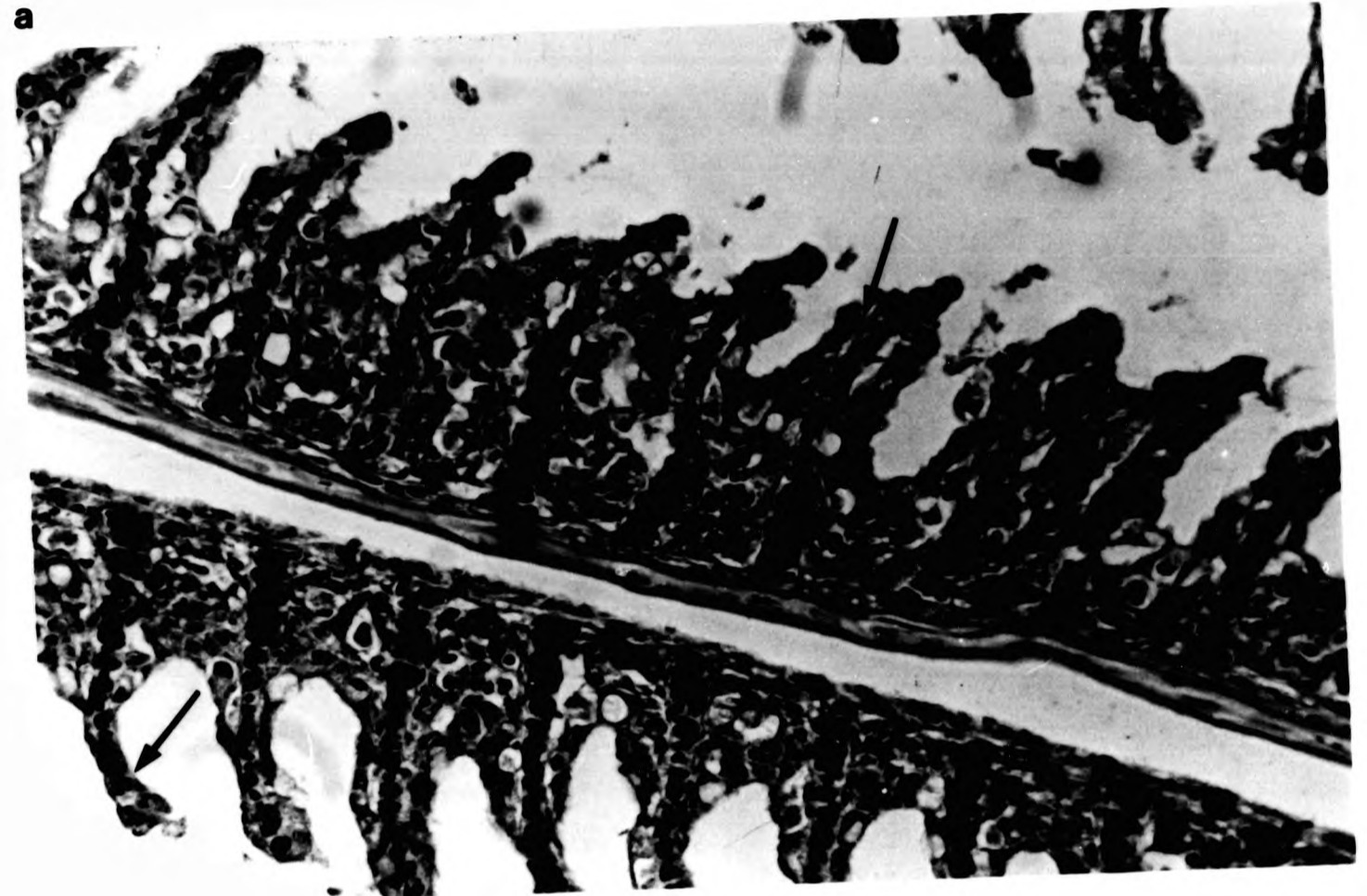

Plate 6

Photomicrographs showing the pathological changes in gills exposed to acid/aluminium

(a) Fish exposed to $150 \mu\text{g Al l}^{-1}$ for 21 days in LCW

Note extensive lamellar swelling and lamellar fusion (wide arrow) and note also erosion of cells (narrow arrow) (H & E, 600 X)



(b) Fish exposed to $100 \mu\text{g Al l}^{-1}$ for 21 days in LCW

Note extensive epithelial swelling and lamellar fusion (wide arrow) with no tissue damage (H & E, 600 X)

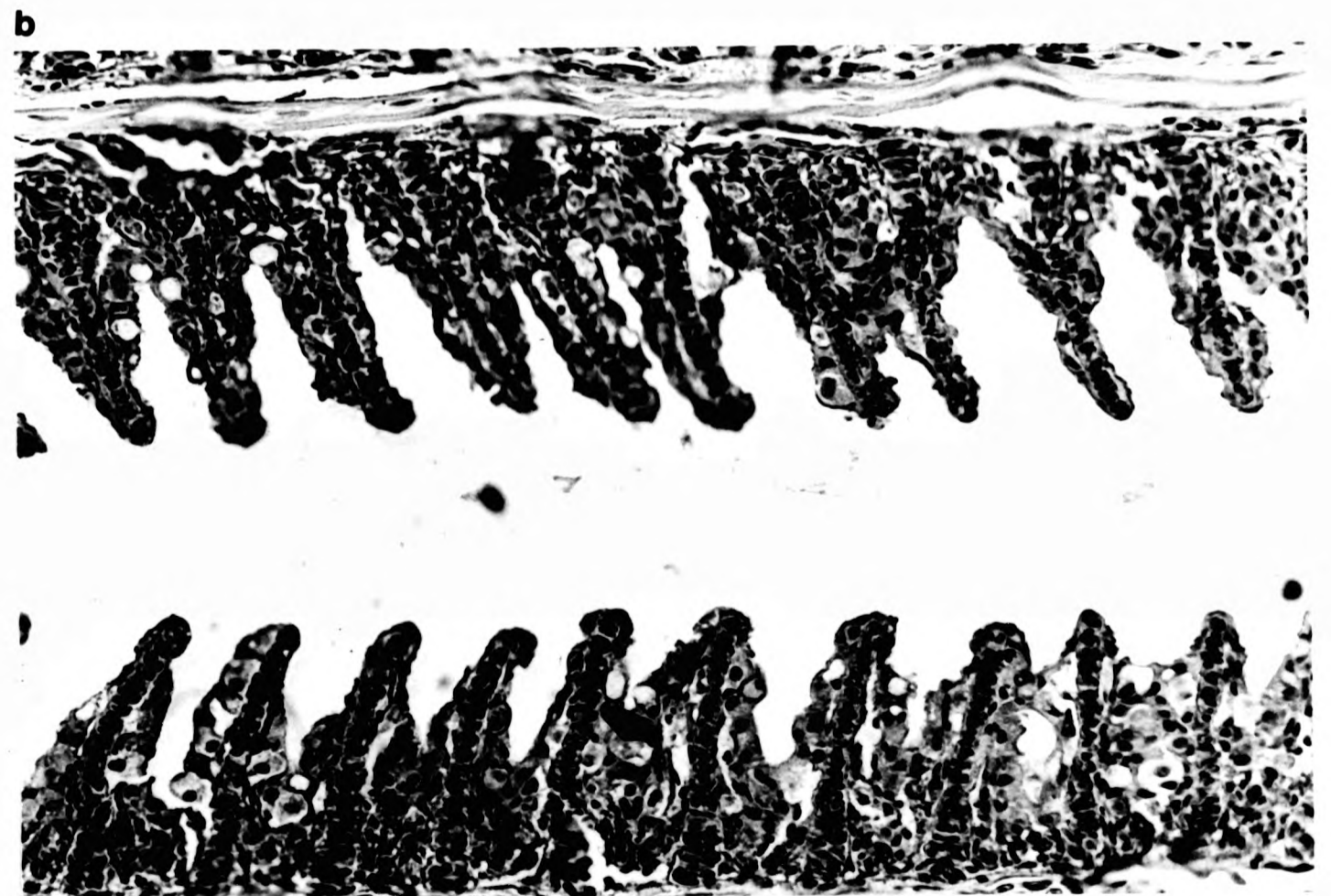
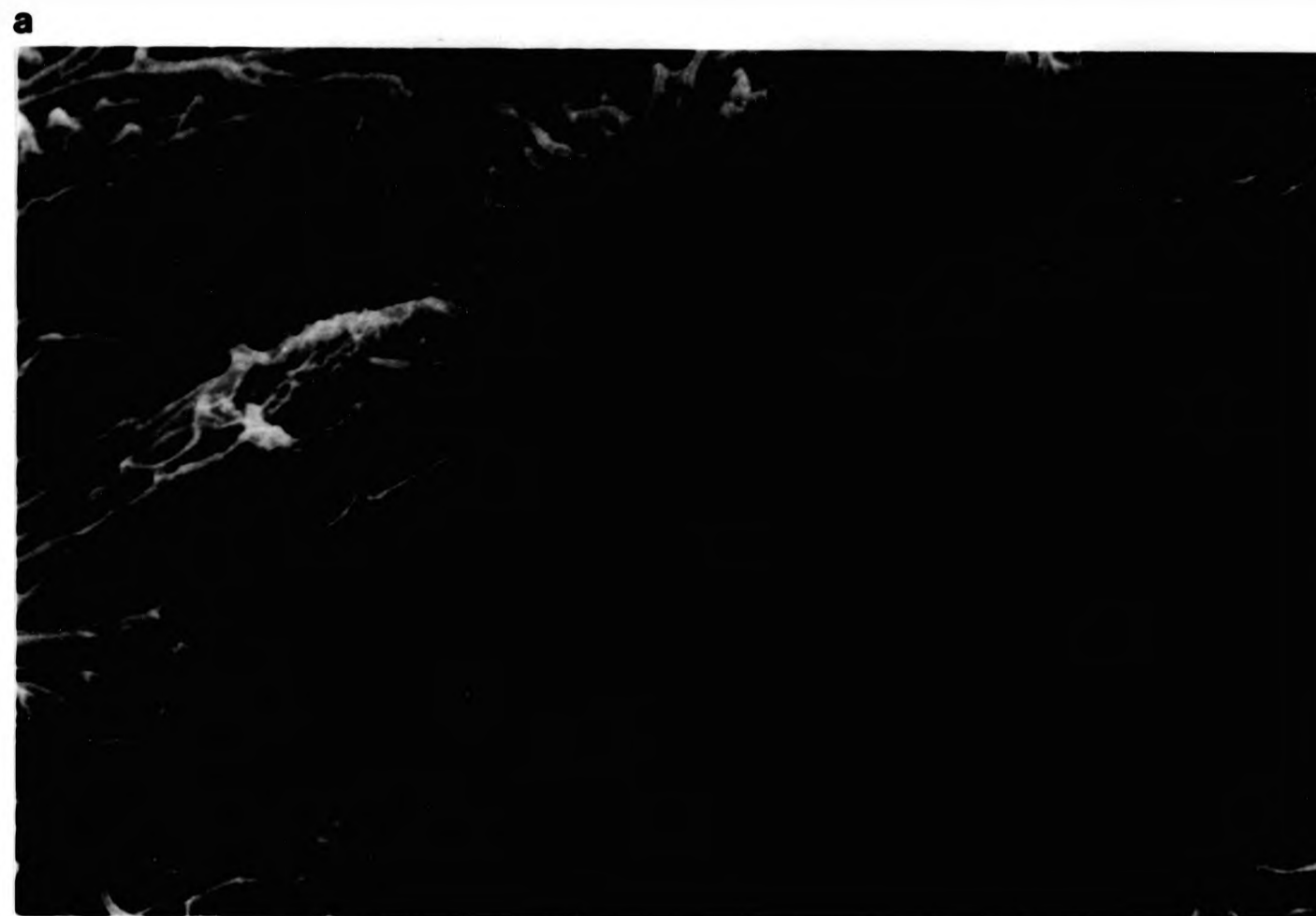

Plate 7

Photomicrographs showing the pathological changes in primary epithelial surface as resolved by SEM

(a) Fish exposed to $50 \mu\text{g Al l}^{-1}$ for 21 days in LCW conditions

Note a thin film of mucus on the primary lamellar surface (4700 X)



(b) Fish exposed to $100 \mu\text{g Al l}^{-1}$ for 21 days under HCW conditions

Note chloride cells bulging out between the epithelial cells. A slight change in microridge pattern without loss of microridges (1650 X)

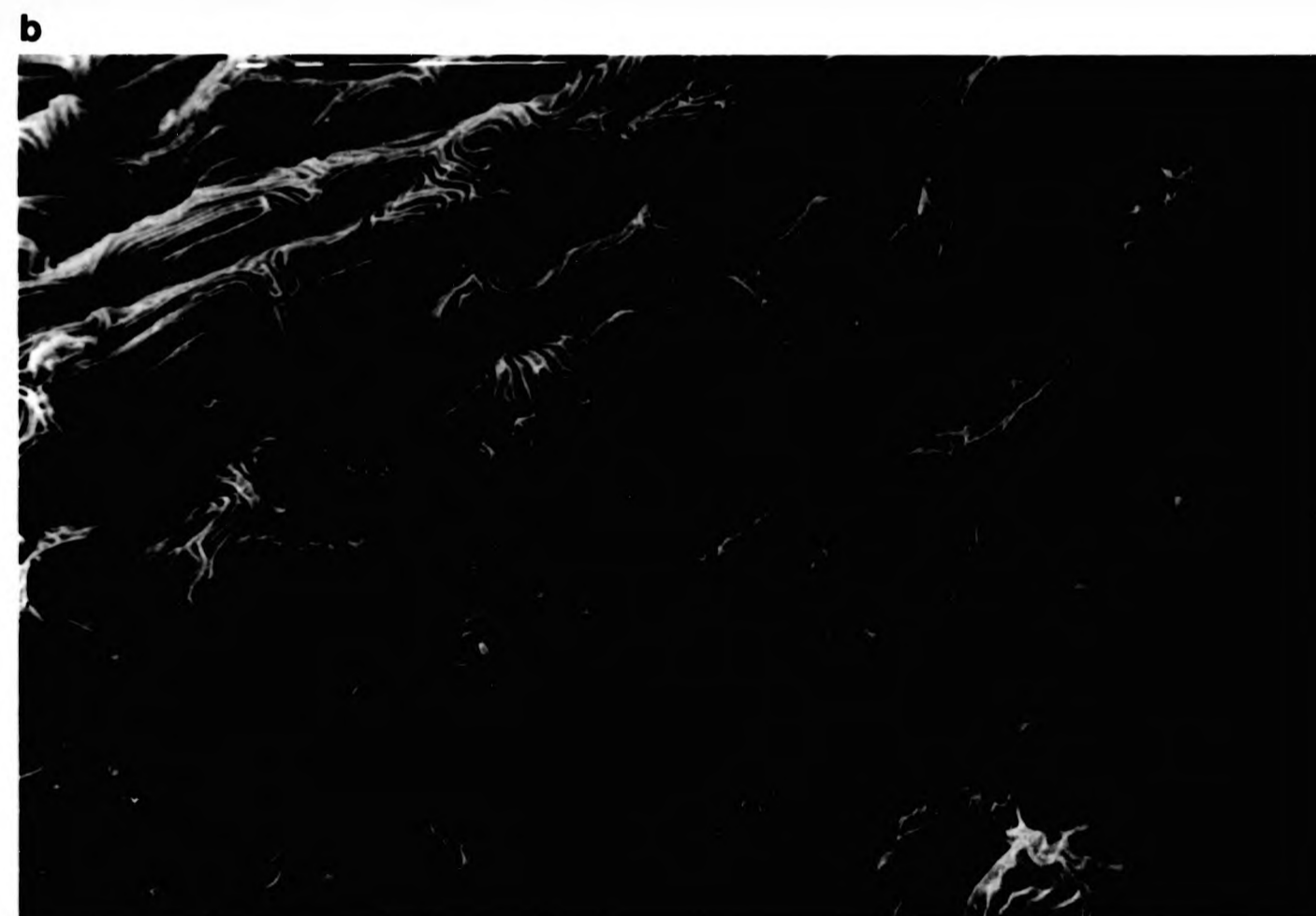

Plate 8

Photomicrographs showing the histopathological changes in gills

(a) Fish exposed to $150 \mu\text{g Al l}^{-1}$ for 21 days in HCW conditions

Note secondary lamellar swelling and mucous clogging, and fusion (arrow) of secondary lamellae at the tips (H & E, 600 X)



(b) Fish exposed to low pH alone for 9 days in HCW conditions

Note normal features of gills (H & E, 600 X)

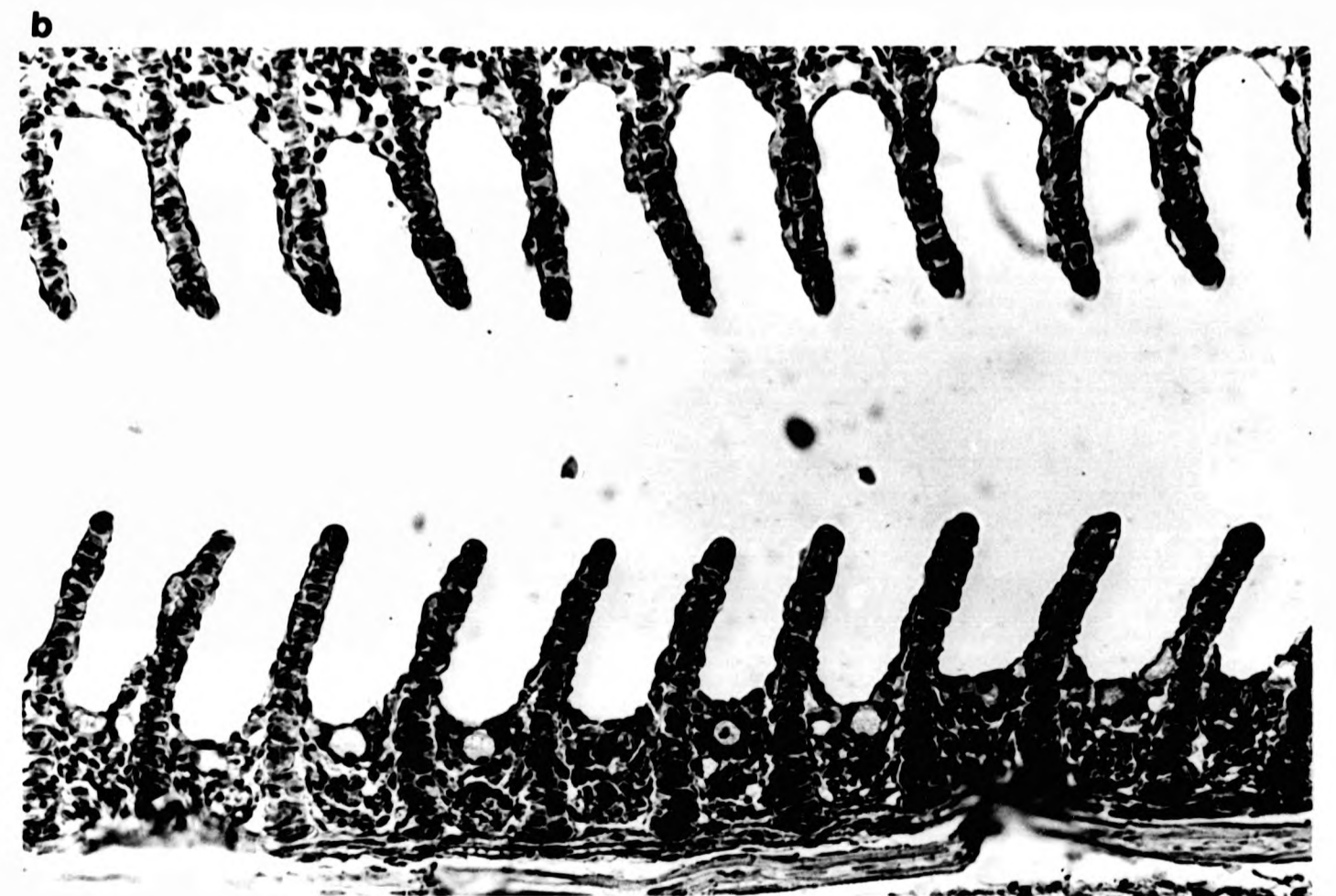

Plate 9

Photomicrographs showing the pathological changes in primary lamellar surface epithelium as resolved by SEM

(a) Fish exposed to $150 \mu\text{g Al l}^{-1}$ for 21 days in HCW conditions

Note partial loss of microridges at places, bulging out of chloride cells (arrow) but no damage to cell surfaces (2050 X)

a

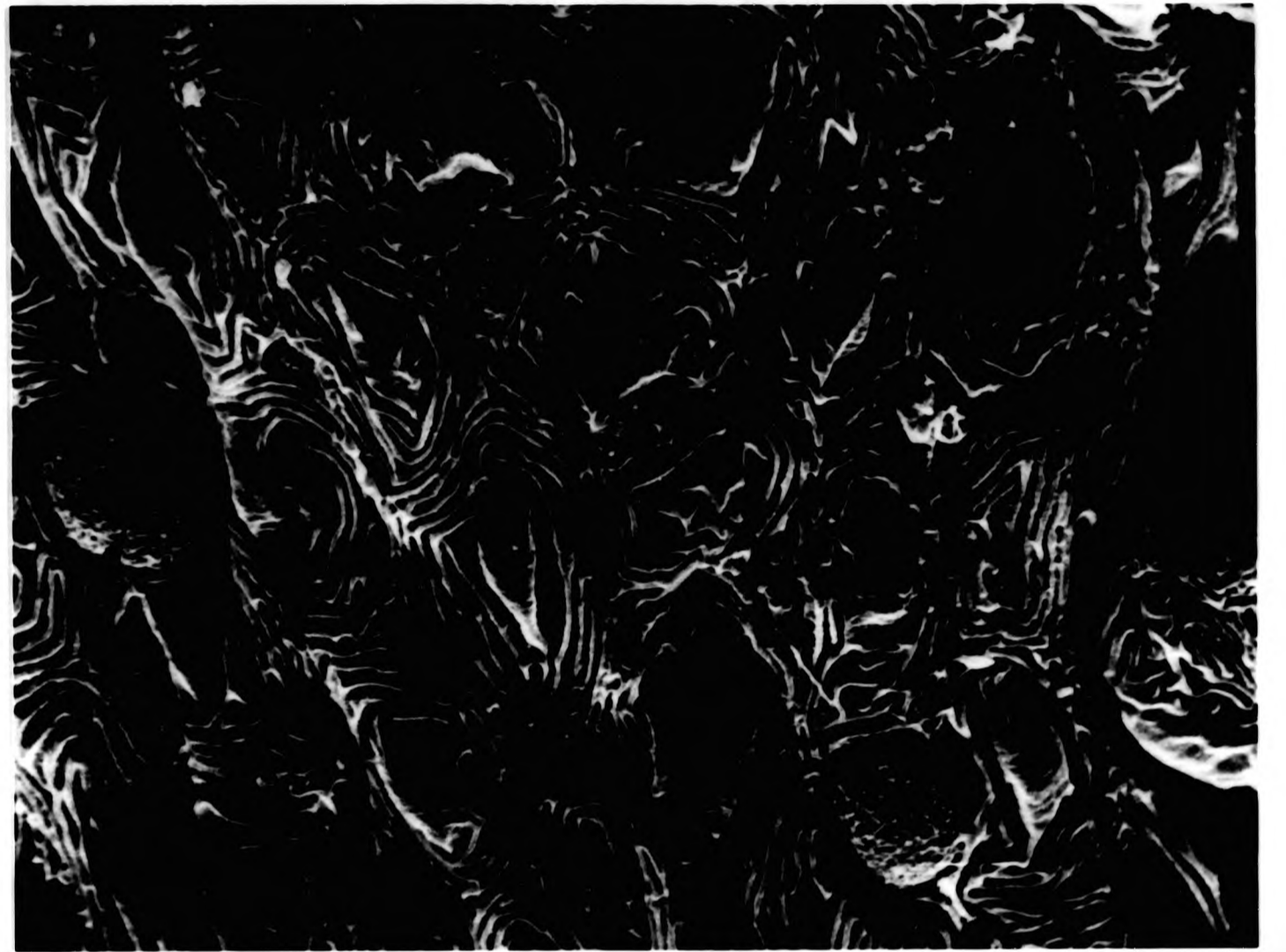

(b) Fish exposed to $150 \mu\text{g Al l}^{-1}$ for 21 days in LCW conditions

Note severe damages to cells (arrows) and partial or total loss of microridges (arrowhead) (2210 X)

b

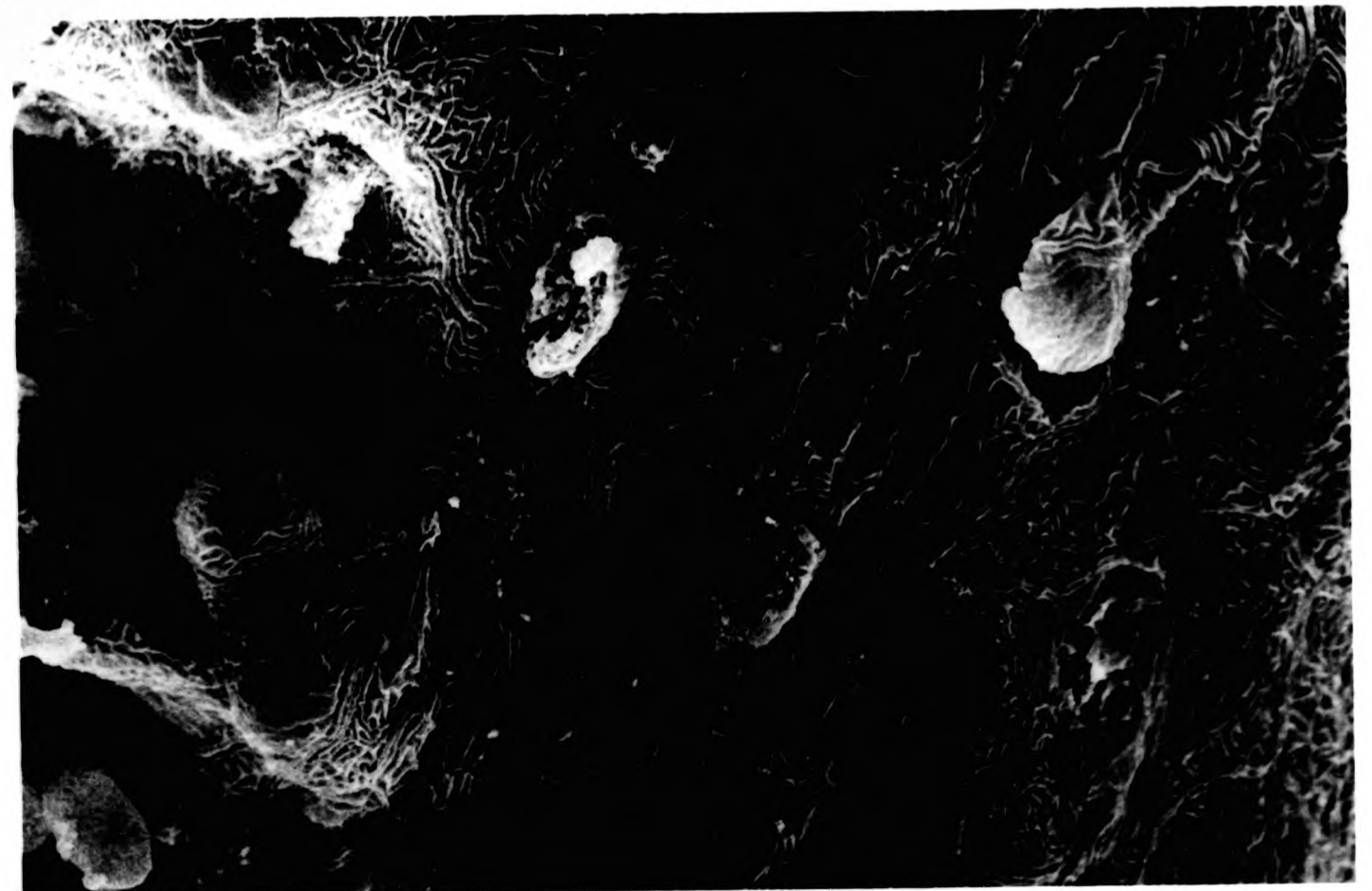

However lamellar fusion was not seen. But increases in intercellular spaces were evident. This group of fish had excess surface mucous than normal as could be seen from the specially stained sections, although surface morphology was near normal (Plate 7.b). No recognizable ultrastructural changes could be detected.

Following exposure to $100 \mu\text{g Al l}^{-1}$ in LCW conditions for 9 days, the gills showed clear swellings of both primary and secondary lamellar epithelia. An increased number of chloride and mucous cells was uniformly represented on most of the lamellae, although the necrotic changes in cells were rare. However, the cells appeared hypertrophic. The hypertrophy of chloride cells were characterized by swollen mitochondria with prominent mitochondrial cristae and more extended tubular systems (Plate 16.b). By the end of the experiment further increases in the above cell types occurred resulting in a rugose appearance of the secondary lamella (Plate 6.b). Due to severe proliferation and hypertrophy of the above cell types, in certain areas of the gill, only very short length of the secondary lamellae were free, the rest being buried within the thickened epithelium. At this stage many chloride cells showed degenerative changes. These included distended mitochondria without mitochondrial cristae, cytoplasmic vacuolation and deformed nucleus. However, such degenerative changes were seen in fewer cells at any given time and as such the whole structure was not seriously affected. At the same time new cells presumably replaced those that were lost. A moderate inter cellular vacuolation was noticed at this stage. Scanning electron microscopy (SEM) revealed extensive secondary lamellar swelling (Plate 12.a). However, a mucous layer covered the epithelial surface.

(d) At $150 \mu\text{g Al l}^{-1}$

After 9 days exposure at this level of aluminium under HCW conditions, the gills appeared to be more thickened (Plate 8.a). An increase in chloride cell number was

observed and mucous cells exhibited a hypertrophic reaction (Plate 14.a). After 21 days of exposure the epithelial thickness increased further with concomitant increases in chloride and mucous cell population (Plate 9.a). Both types of cell showed increased activity. However, degenerative changes in chloride cells were not common. A thick layer of surface mucus was consistently observed. Epithelial cells appeared to be distended and a partial loss of primary epithelial microridges was observed in many specimens (Plate 9.a). Occasionally lamellar fusion was seen.

The basic pathological changes seen in the earlier group of fish ($100 \mu\text{g Al l}^{-1}$) under LCW conditions qualitatively remained same for this group of fish as well. However, the extent of the changes were greater at this higher concentration of aluminium. After 2 days of exposure, although the gills showed no noticeable changes in cell proliferation, hypertrophic reaction was obvious (Plates 10.a & 10.b). However, dramatic increases in chloride and mucous cell populations occurred after 9 days exposure and some of the chloride cells bulged out between the epithelial cells (Plate 11.a). Hypertrophic reaction was seen in all cell types including epithelial cells. Large increases in intercellular spaces were evident. The above noted changes resulted in an extremely rugose appearance of the gill tissue (Plate 10). Degenerative changes in cells, especially in chloride cells, were seen by this time. By day 21 of exposure, however, there was little further increase in lamellar thickness (visual). However, fusion of secondary lamellae appeared in more areas and the epithelium looked extremely rugose in appearance (Plate 6.a). Chloride cell numbers appeared to be reduced (visual) in the lamellar epithelium (compare Plate 13.a & 13.b), particularly on the secondary lamellae, although this was variable. A large number of chloride cells showed degenerative changes including dark and distended or deformed mitochondria, cytoplasmic vacuolation, darkening of cytoplasmic matrix, dissolution of nuclear membrane (Plates 13.b & 14.b). The characteristic changes at this aluminium concentration were the

Plate 10

Photomicrographs showing the pathological changes in gill tissue in tilapia during acid/aluminium exposure as seen in histological sections.

Note extensive swelling, mucous clogging of secondary lamellae and extensive presence of chloride cells in the secondary lamellar epithelium

(a) A representative secondary lamellae in fish exposed to $150 \mu\text{g Al l}^{-1}$ for 9 days in LCW conditions (1500 X)

(b) Same at lower magnification (600 X)

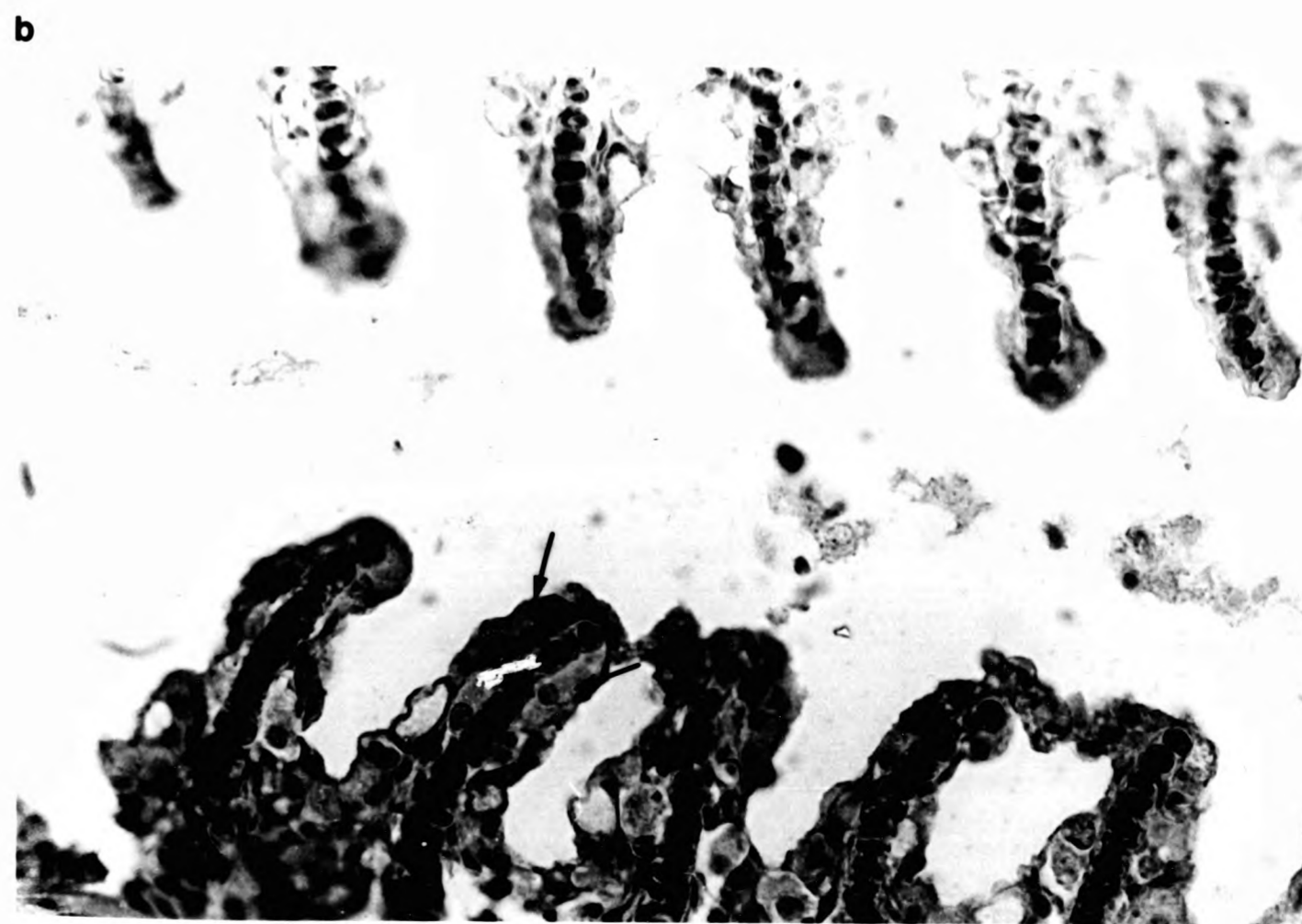

Plate 11

Photomicrographs showing changes in secondary lamellar surface epithelia as resolved by SEM

(a) Fish exposed to $150 \mu\text{g Al l}^{-1}$ for 9 days in LCW conditions

Note extensive proliferation and bulging out of cells and extensive presence of surface mucus (arrow) (1140 X)

(b) Fish exposed to $150 \mu\text{g Al l}^{-1}$ for 21 days in LCW conditions

Note a decrease in cell population (compare with the above) and note also the loss of surface microridges (arrowhead) and less surface mucus (1910 X)

(c) Gill arch surface in fish exposed for 9 days to $150 \mu\text{g Al l}^{-1}$ in LCW conditions

Note excessive mucus secretion and wide mucous cell pore (arrow)

(d) Secondary lamellae of fish exposed to $150 \mu\text{g Al l}^{-1}$ in LCW for 9 days (higher magnification of plate 11a)

Note loss of intercellular adhesion (arrow) and precipitated mucus (arrowhead) (4200 X)

a

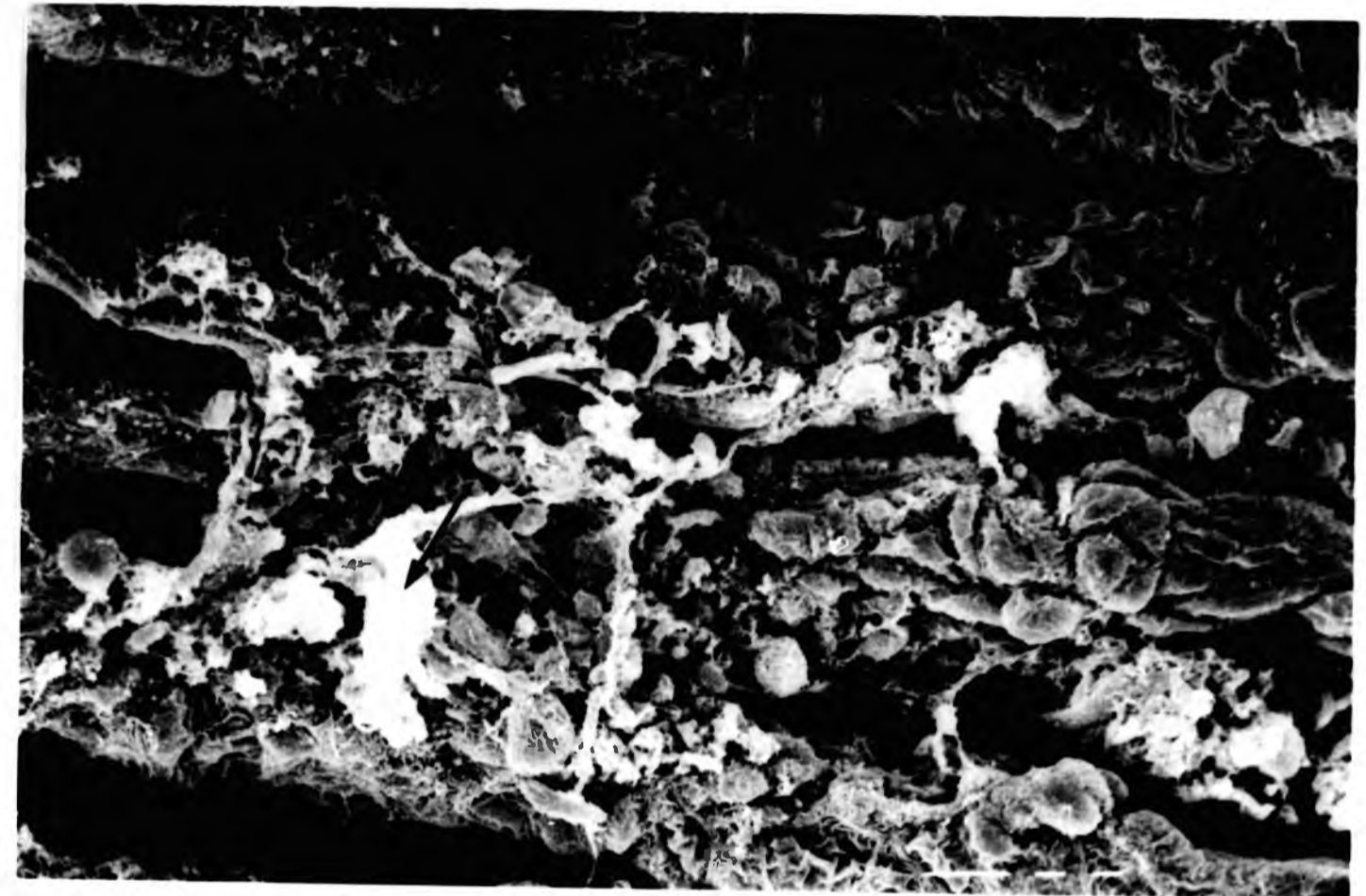

b

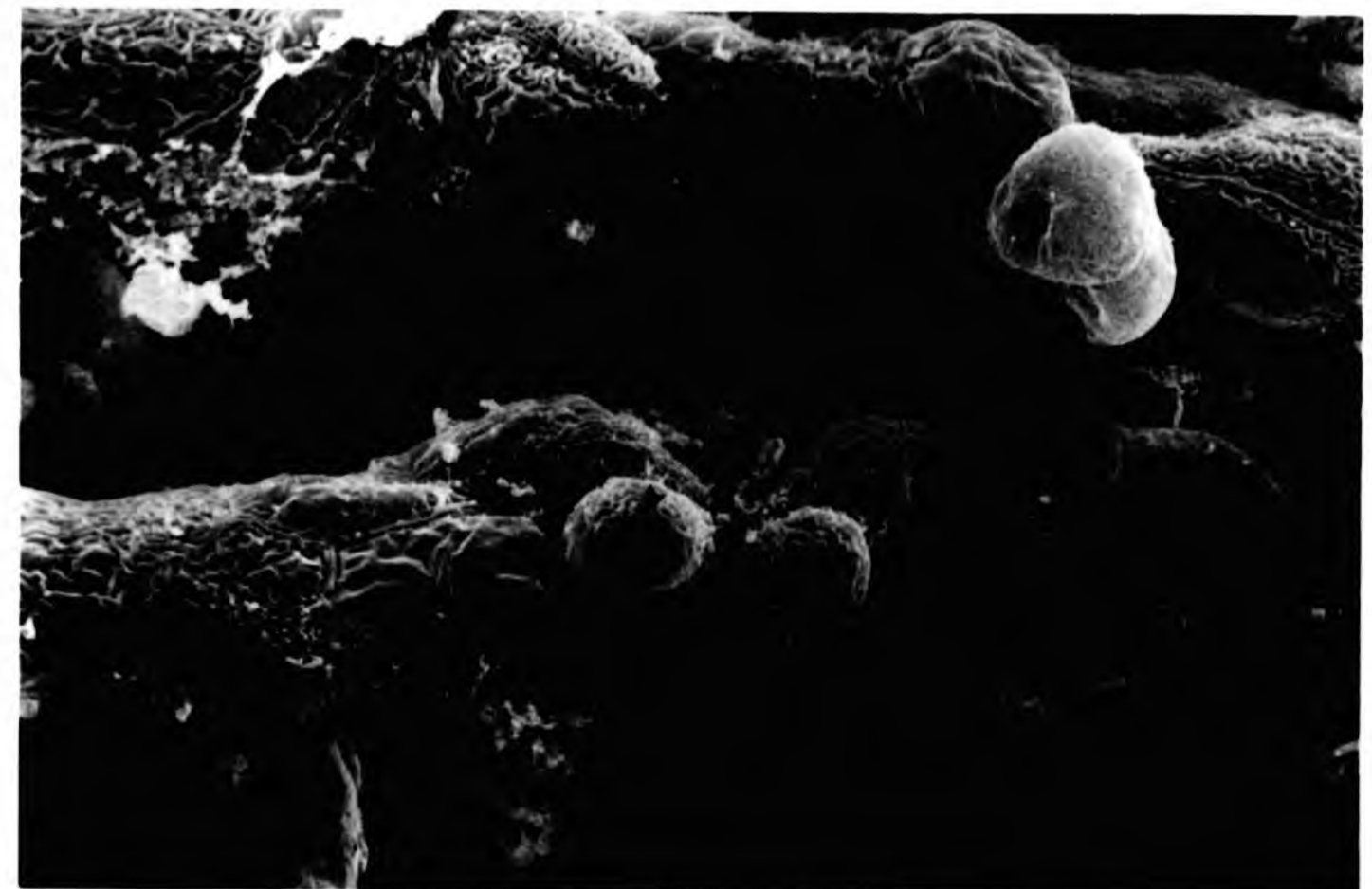

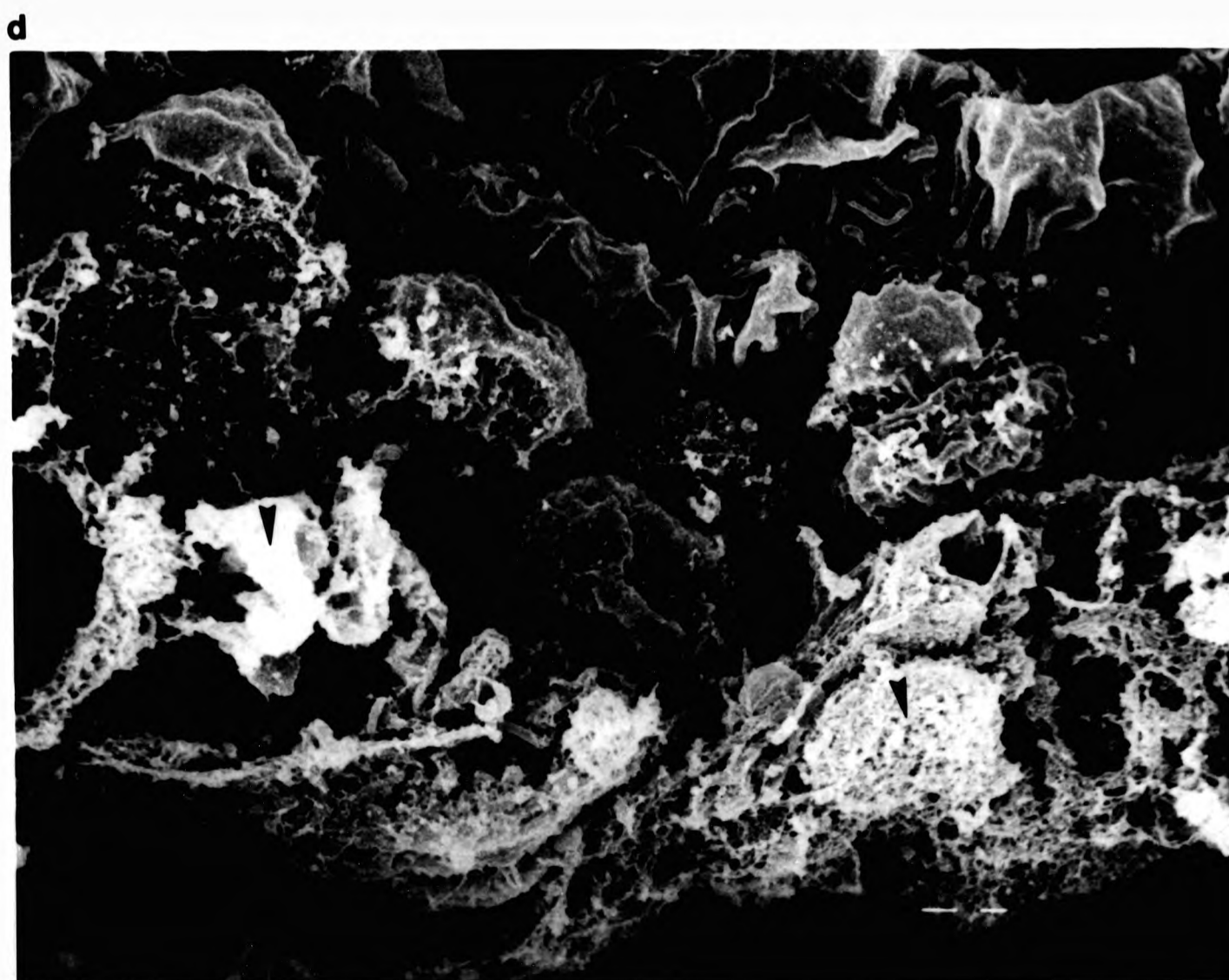
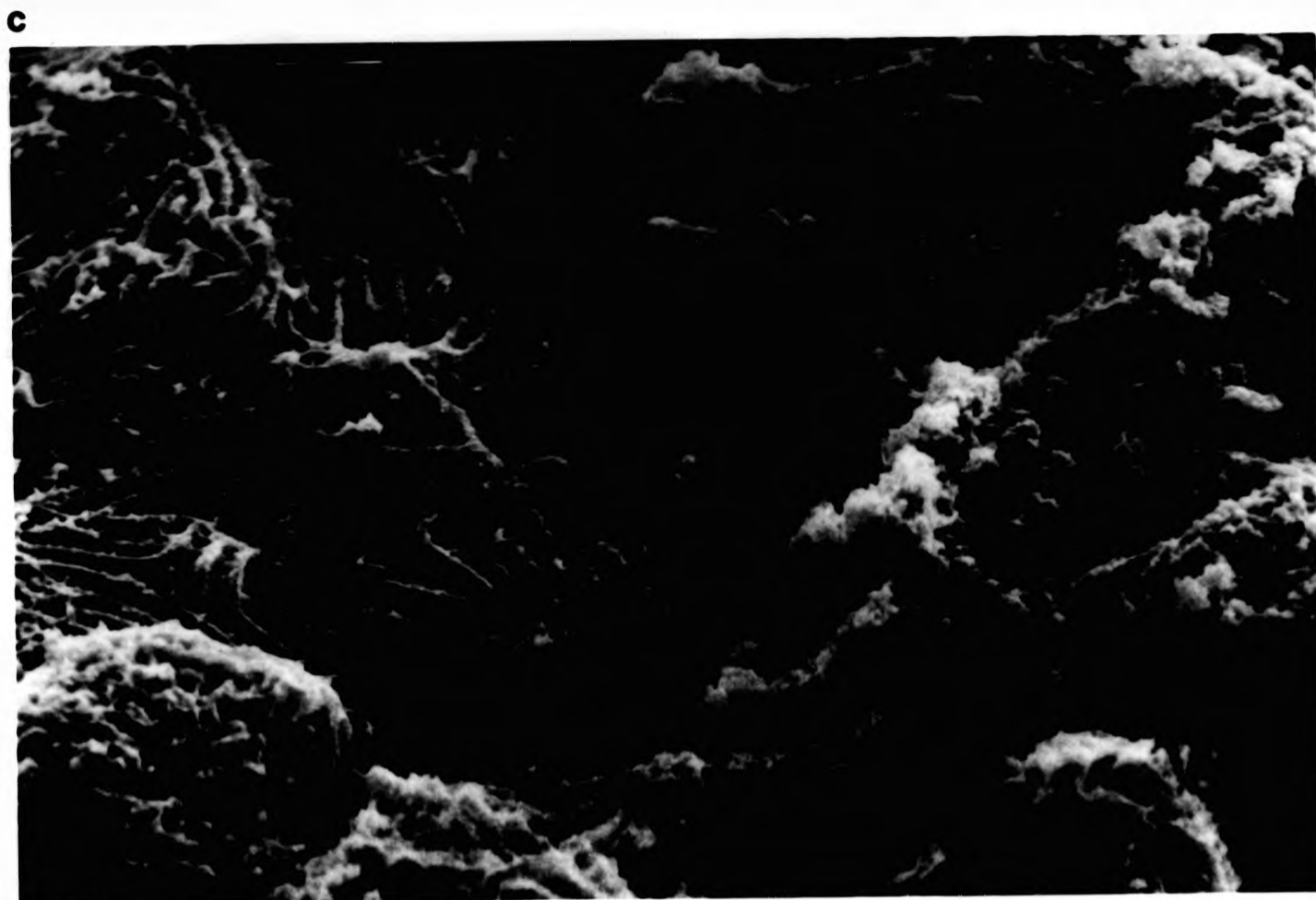

Plate 12

Photomicrographs showing changes in surface morphology as resolved by SEM

(a) Secondary lamellae in fish exposed to $100 \mu\text{g Al l}^{-1}$ for 21 days in LCW conditions
Note extremely hypertrophied cells covered with thick mucous coat concealing microridges. No damages to surface epithelia is evident (4700 X)



(b) A selected area on the primary lamella in fish exposed to $150 \mu\text{g Al l}^{-1}$ for 21 days
Note severe damages to surface epithelia, total loss of surface microridges (this observation was not consistent) (2370 X)

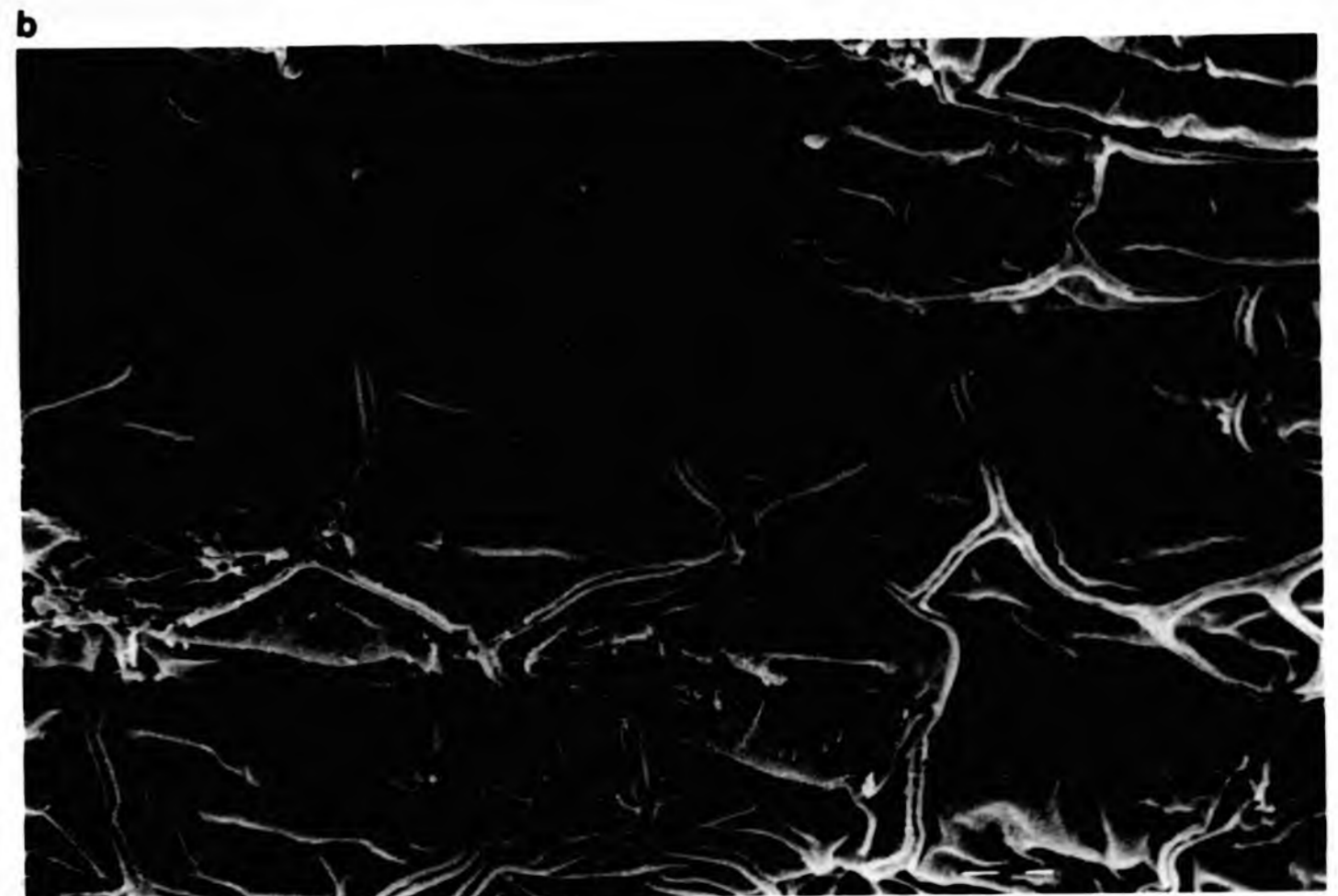

Plate 13

Photomicrographs showing the pathological changes in secondary lamellae in gills exposed to $150 \mu\text{g Al l}^{-1}$ in LCW conditions as resolved by TEM

(a) After 9 days of exposure

Note the extensive presence of chloride cells (cc) and intercellular spaces (arrowhead)
(4410 X)



(b) After 21 days of exposure

Note degenerative changes in chloride cells including deformed nucleus (arrowhead) and occurrence of cytoplasmic vacuolation (wide arrow) and note also a decrease in chloride cell population (2950 X)

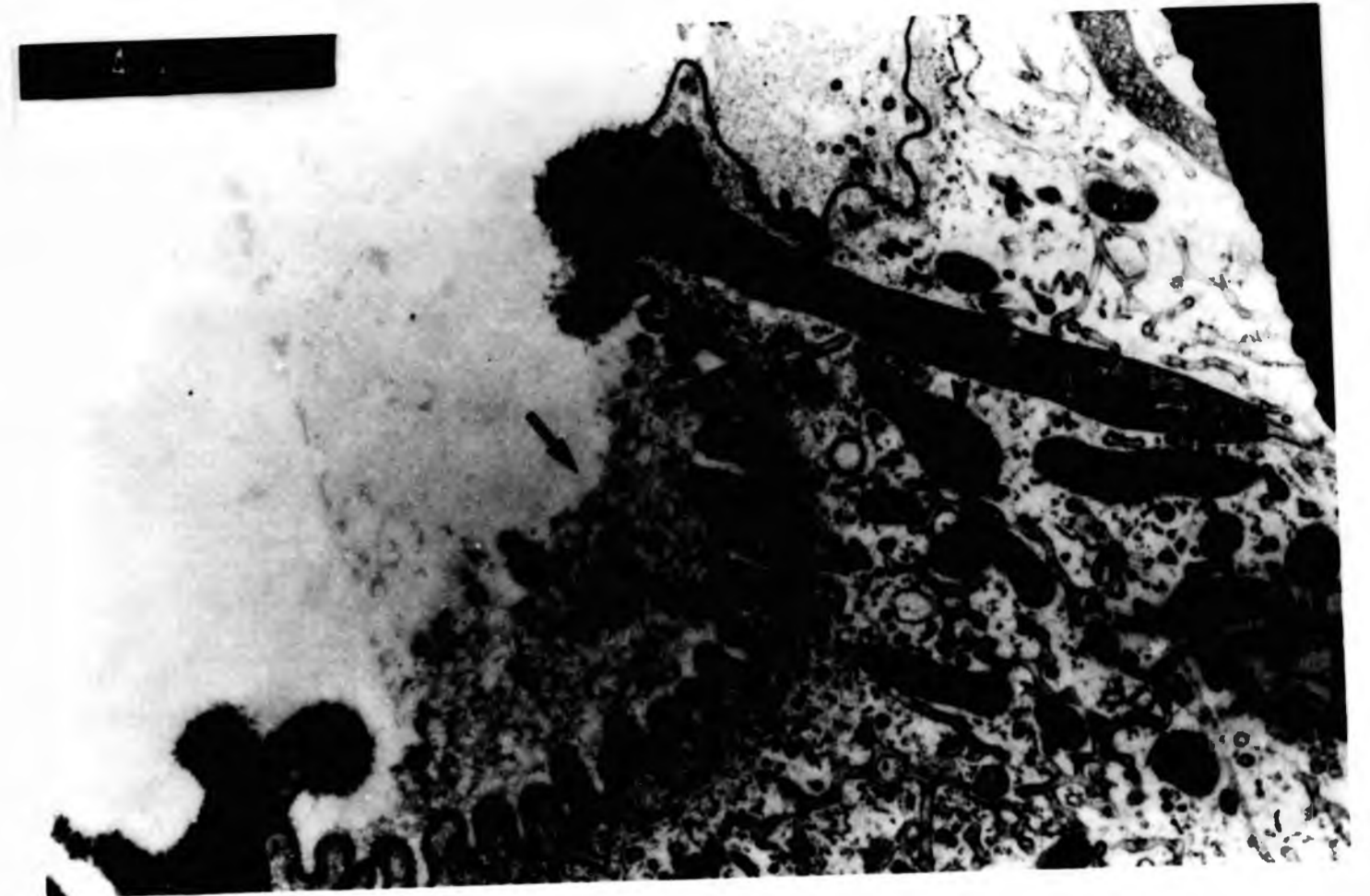

Plate 14

Photomicrographs showing pathological changes in chloride cells as resolved by TEM

(a) Fish exposed to $150 \mu\text{g Al l}^{-1}$ for 9 days in HCW conditions

Note a fully functioning chloride cell with apical pit (narrow arrow), hypertrophied mitochondria with normal cristae (arrowhead). Note also the presence of accessory cells (wide arrow) (6250 X)



(b) Fish exposed to 150 Al l^{-1} for 21 days in LCW conditions

Note degenerative changes including dissolution of nuclear membrane, distended mitochondria without cristae (arrowhead), cytoplasmic vacuolation) (6030 X)

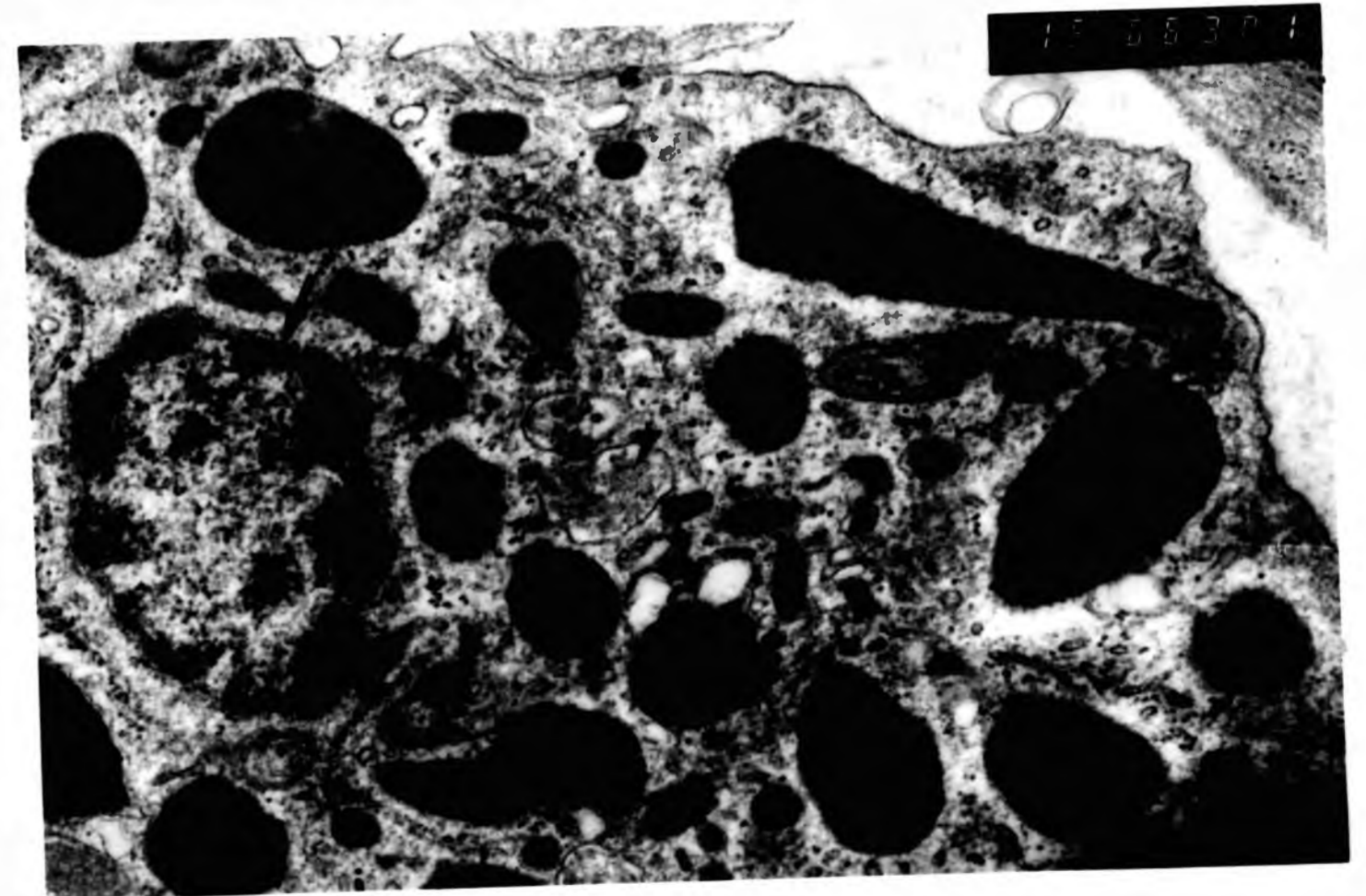
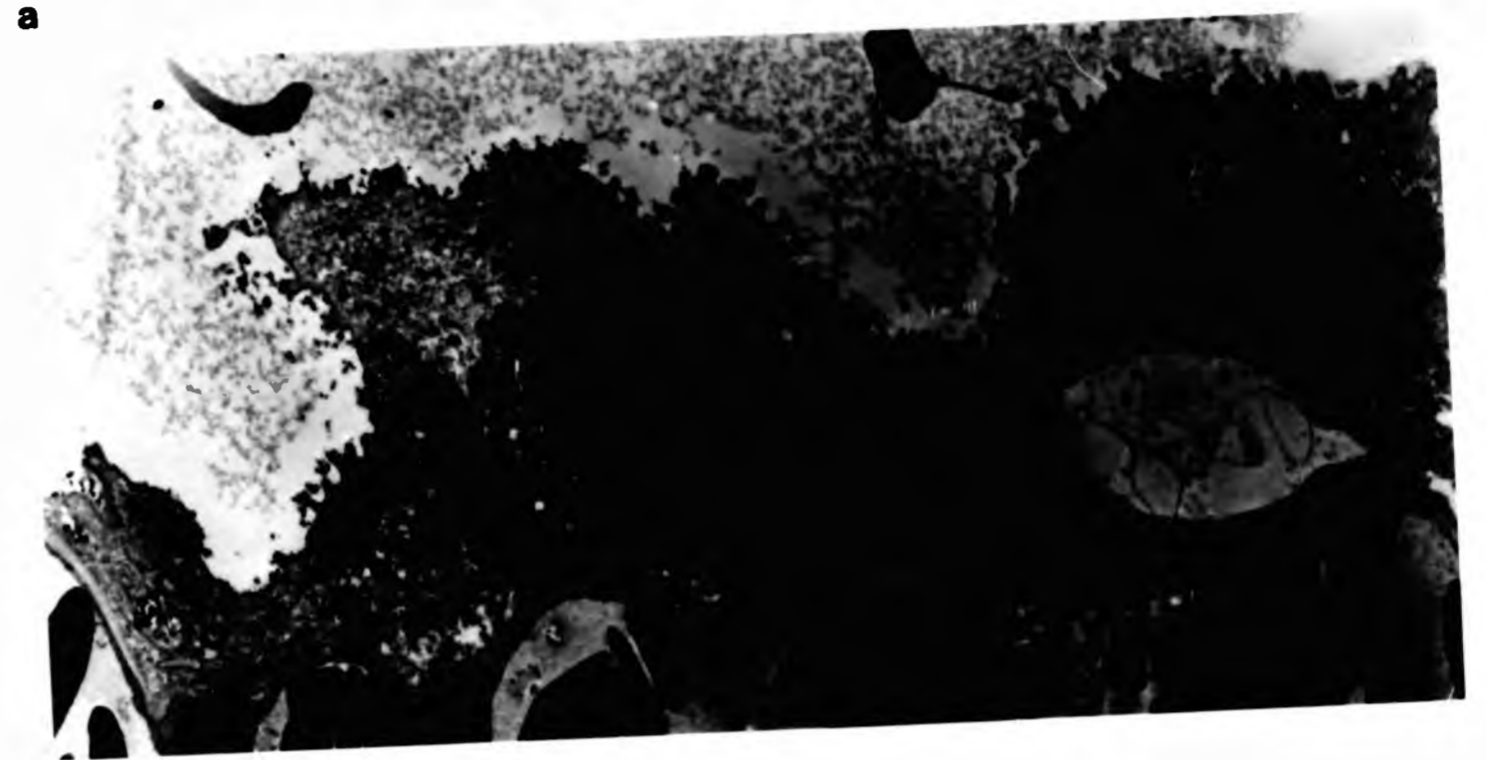

Plate 15

Photomicrograph showing pathological changes in gills as resolved by TEM

(a) Fish exposed to $150 \mu\text{g Al l}^{-1}$ for 21 days in LCW conditions

Note extensive hyperplasia and hypertrophy of epithelial cells (arrowhead) and loss of characteristic epithelial cell shape. Note also a decrease abundance in chloride cell numbers (compare with plate 13 a) (4020 X)



(b) Fish exposed to $150 \mu\text{g Al l}^{-1}$ for 21 days in LCW

Note degenerative changes in mucous cells including darkening of mucous globules (arrow) (5800 X)



Plate 16

Photomicrographs showing changes in chloride cells as resolved by TEM

(a) Fish exposed to $100 \mu\text{g Al l}^{-1}$ for 21 days in HCW conditions

Note a near normal hypertrophied chloride cell with exposed apical surface (arrow)

(5160 X)

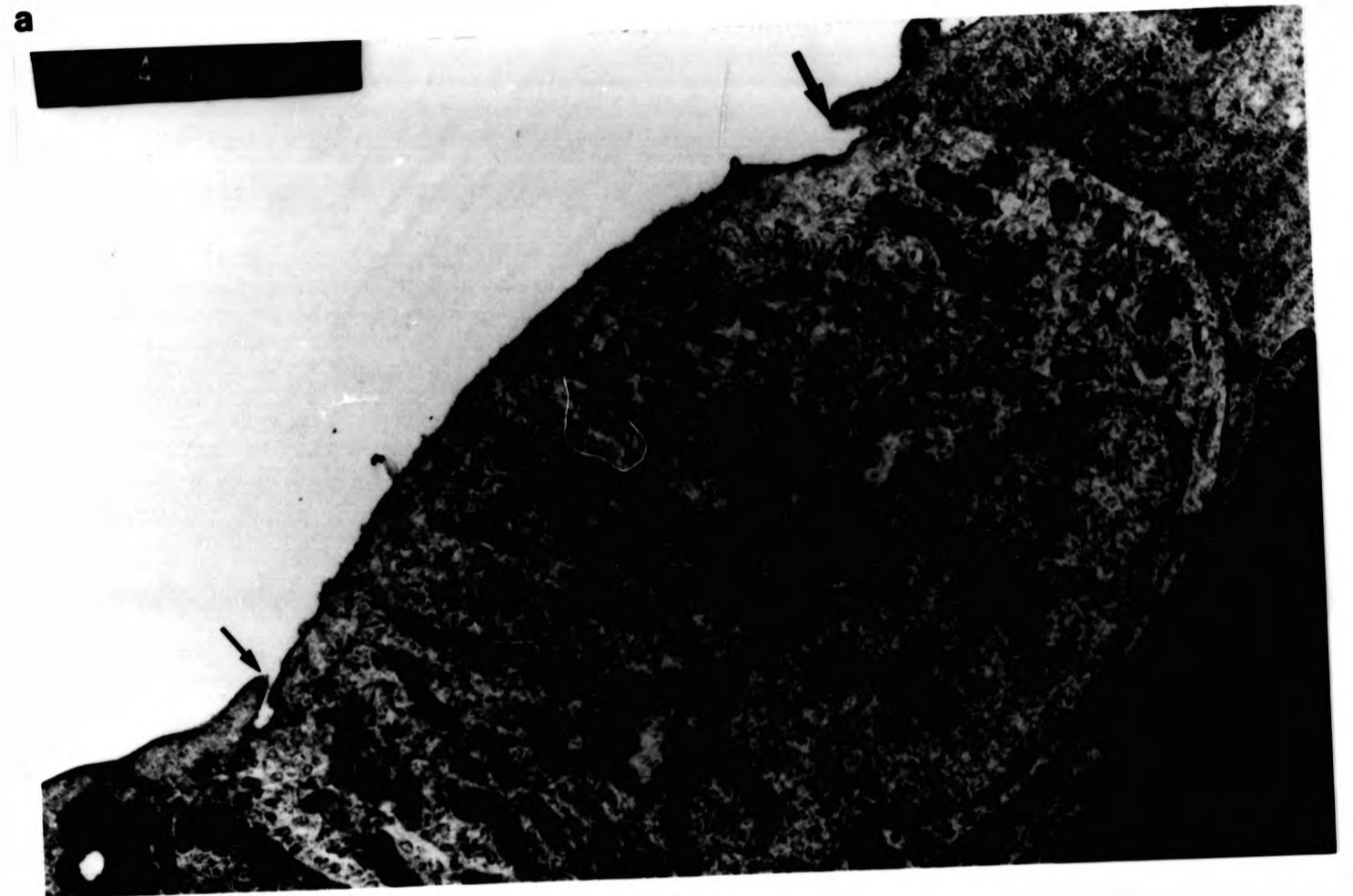

(b) Fish exposed to $100 \mu\text{g Al l}^{-1}$ for 9 days in LCW conditions

Note changes in cytoplasm (4480 X)

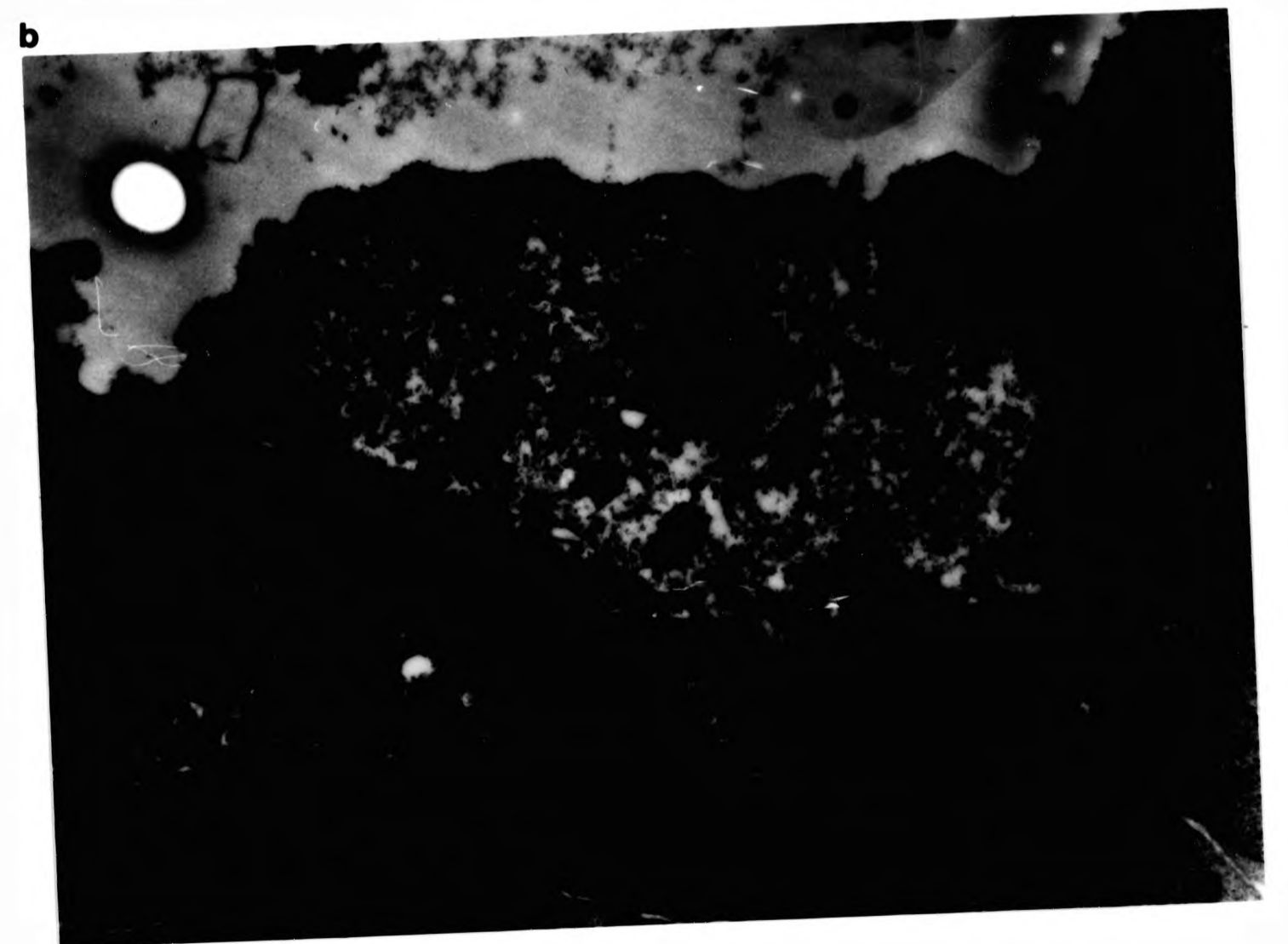

occurrence of hyperplasia (proliferation of epithelial cells), particularly after 21 days exposure (Plate 15.a). This group of cell showed extensive swellings and appeared rugose in shape. These cells also showed more advance stages of cytoplasmic changes, such as severe vacuolation, loss of structural integrity of cellular organelles and darkening of the cytoplasmic matrix (Plate 13.b). The primary epithelial microridges were partially or completely lost (Plates 9.b & 12.b). Many mucous cells also showed degenerative changes characterized by loss of cellular integrity, exhaustion of mucous reserves and darkening of mucus globules (Plate 15.b). Many chloride cells alongside the pathological ones were enlarged although otherwise appeared unaffected.

7.2.2. Short-term Experiments

(a) Control

After 4 days of exposure, the control gills (maintained at circumneutral pH without added aluminium either in LCW or HCW conditions) appeared normal and were morphologically similar to those as described for LCW and HCW acclimated fish, respectively (see Plate 17).

(b) At $0 \mu\text{g Al l}^{-1}$

As with previous experiments, exposure to acidic water (pH 5.2) alone, either in LCW or HCW conditions, did not cause any marked changes in structure and ultrastructure in comparison with respective control gills. However, increased mucous cell activity was evident, particularly in fish under LCW environments.

(c) At $120 \mu\text{g Al l}^{-1}$

Under conditions of LCW, exposure to $120 \mu\text{g Al l}^{-1}$ for 4 days resulted in mild proliferative changes in chloride and mucous cells, although their presence on the secondary lamellar epithelium was not a major observation. Both the cell types showed

Plate 17

Photomicrographs from histological sections of control gills (at pH 6.8 with no added aluminium) specially stained to demonstrate the distribution of mucous cells. Note that the mucous cells are confined in primary lamellar epithelium. Gill morphology is perfectly normal.

(a) Stained with PAS

(b) Stained with alcian blue

a

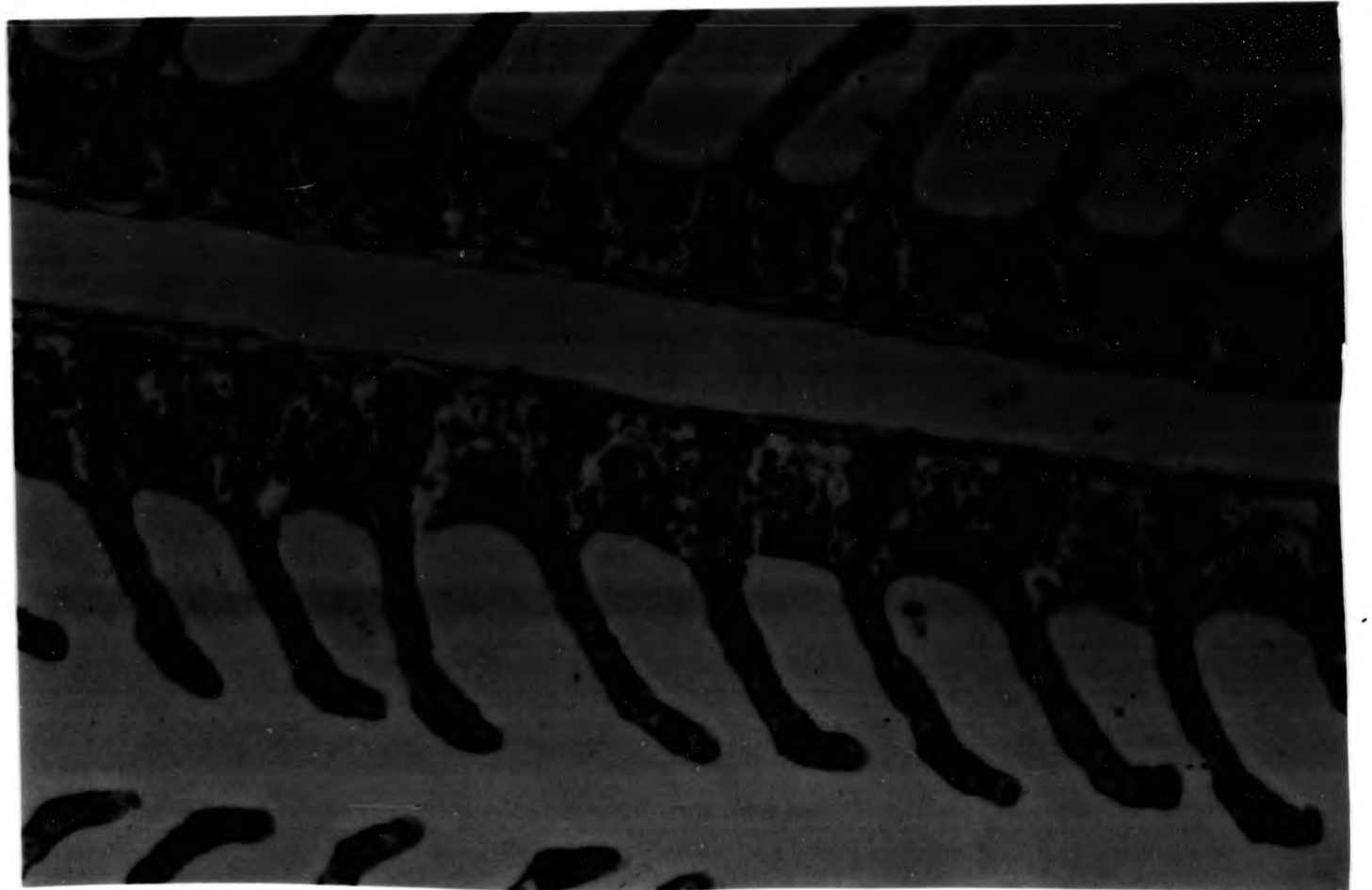

b



Plate 18

Photomicrographs showing pathological changes in gills exposed to acid/aluminium conditions for 4 days

(a) Fish exposed to $320 \mu\text{g Al l}^{-1}$ in LCW conditions

Note swelling and fusion of secondary lamellae and loss of secondary lamellar epithelium (arrow) (H & E, 600 X)

(b) Fish exposed to $320 \mu\text{g Al l}^{-1}$ for 4 days in HCW conditions

Note moderate swelling of lamellar swelling and mucus clogging of secondary lamellae (600 X)

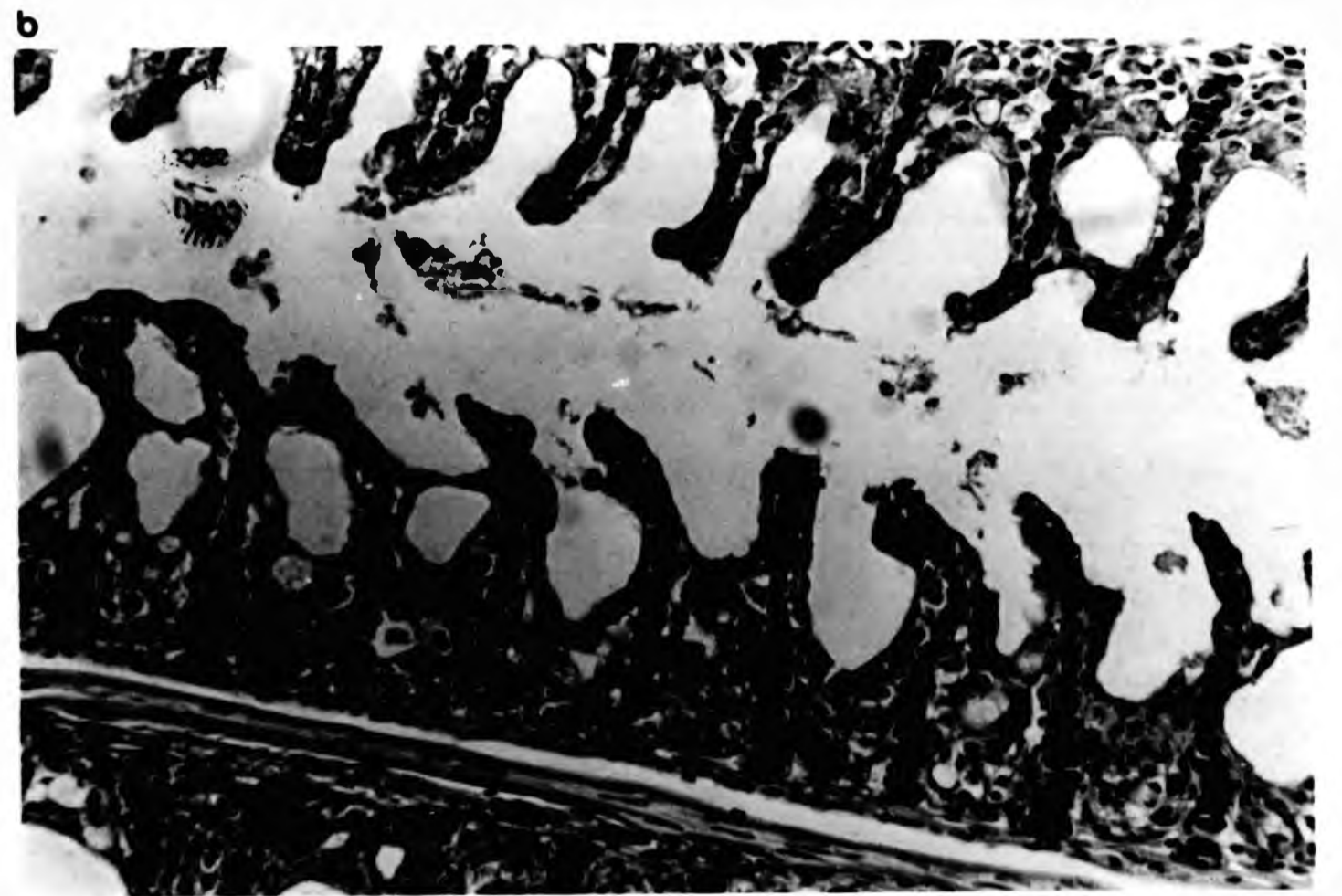

clear signs of swelling (hypertrophy), although cellular integrity remained intact. Surface microridge patterns appeared to be disrupted at places. A surface mucus coat was visible, although typical mucus clogging of lamellae was not consistently observed.

The corresponding group of fish under HCW conditions also showed increased mucous cell activity in gills but changes in chloride cells were not apparent. No noticeable changes in surface morphology or cellular organelles were observed. However, a surface mucous film was obvious (Plate 21.b)

(c) At $220 \mu\text{g Al l}^{-1}$

Considerable changes in gill structure and ultrastructure were noted in this group of fish under LCW conditions. Both primary and secondary lamellar epithelia showed marked swelling. This was primarily due to proliferative and hypertrophic responses in chloride and mucous cells. Many mucous cells appeared to be vacuolated and the chloride cell mitochondria were greatly swollen, although degenerative changes were rare. The surface microridge pattern appeared to be broken in places.

Fish in HCW conditions also showed variable to mild increases in the above cell types. However, cell or tissue damages were not seen. A thick film of surface mucus usually covered the gill surface.

(d) At $320 \mu\text{g Al l}^{-1}$

After 4 days of exposure, this group of fish under LCW conditions showed secondary lamellar fusion and severe gill damage (Plates 18.a & 20.a). The prominent feature in specimens exposed to $150 \mu\text{g Al}$ was the appearance of large intercellular spaces and epithelial lifting. The swelling of intercellular spaces had progressed to a stage where large parts of the epithelia had become detached from the basal membrane of the

Plate 19

Photomicrographs showing the histopathological changes in acid/aluminium-exposed gills

Fish exposed to $520 \mu\text{g Al l}^{-1}$ for 4 days in HCW conditions

Note primary lamellar thickening (arrowhead) and proliferation of mucous cells and their presence in the secondary lamellar epithelium (arrow)

a



Plate 20

Photomicrograph showing surface morphology of primary lamellar epithelium as resolved by SEM

(a) Fish exposed to $320 \mu\text{g Al l}^{-1}$ for 4 days in LCW conditions

Note the partial loss of microridges, and damage to epithelial and underlying cells (arrow)

(b) Fish exposed to $320 \mu\text{g Al l}^{-1}$ for 4 days under HCW conditions

Note the partial loss of surface microridges but no damage to cells (2260 X)

a

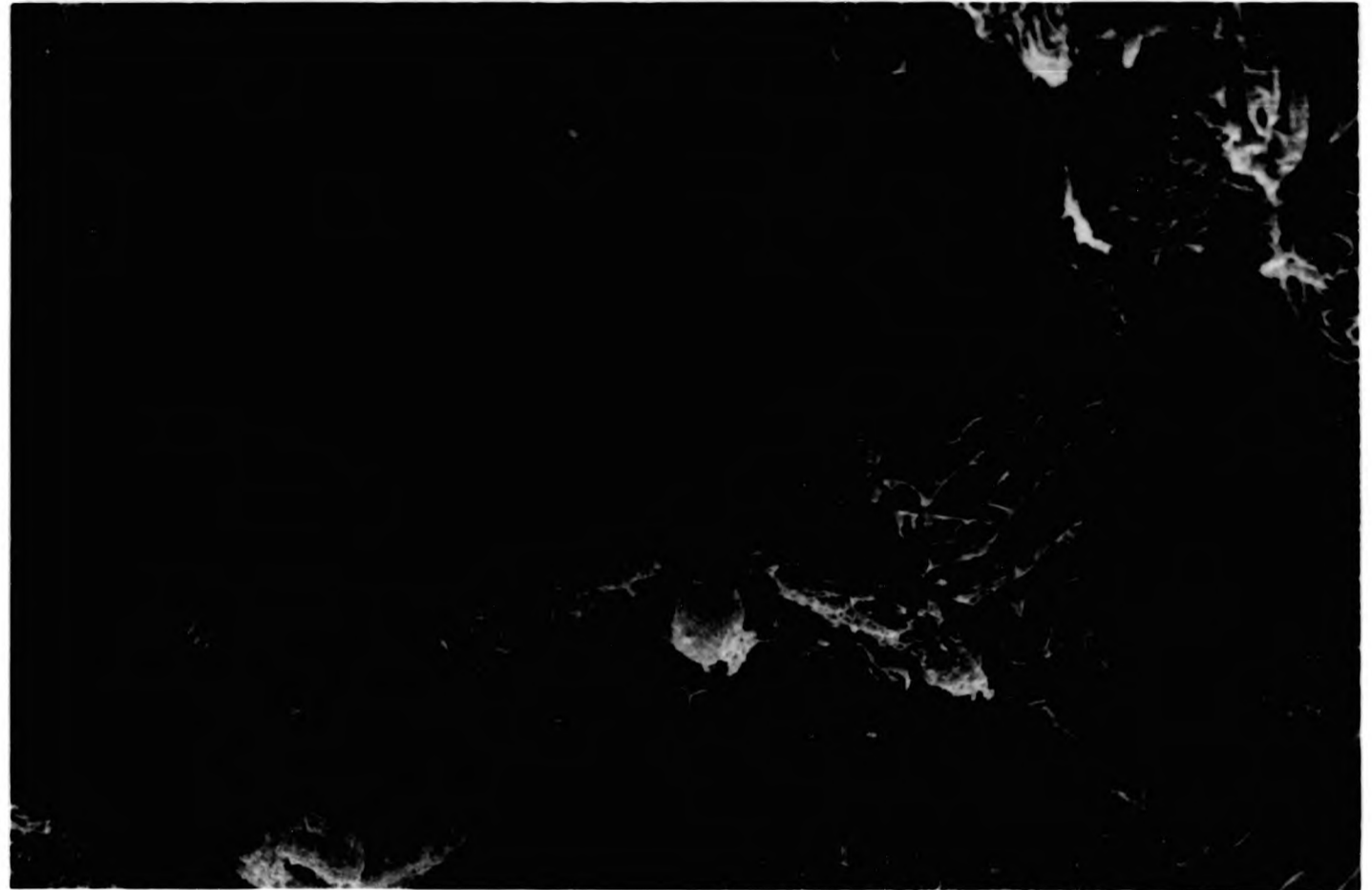

b

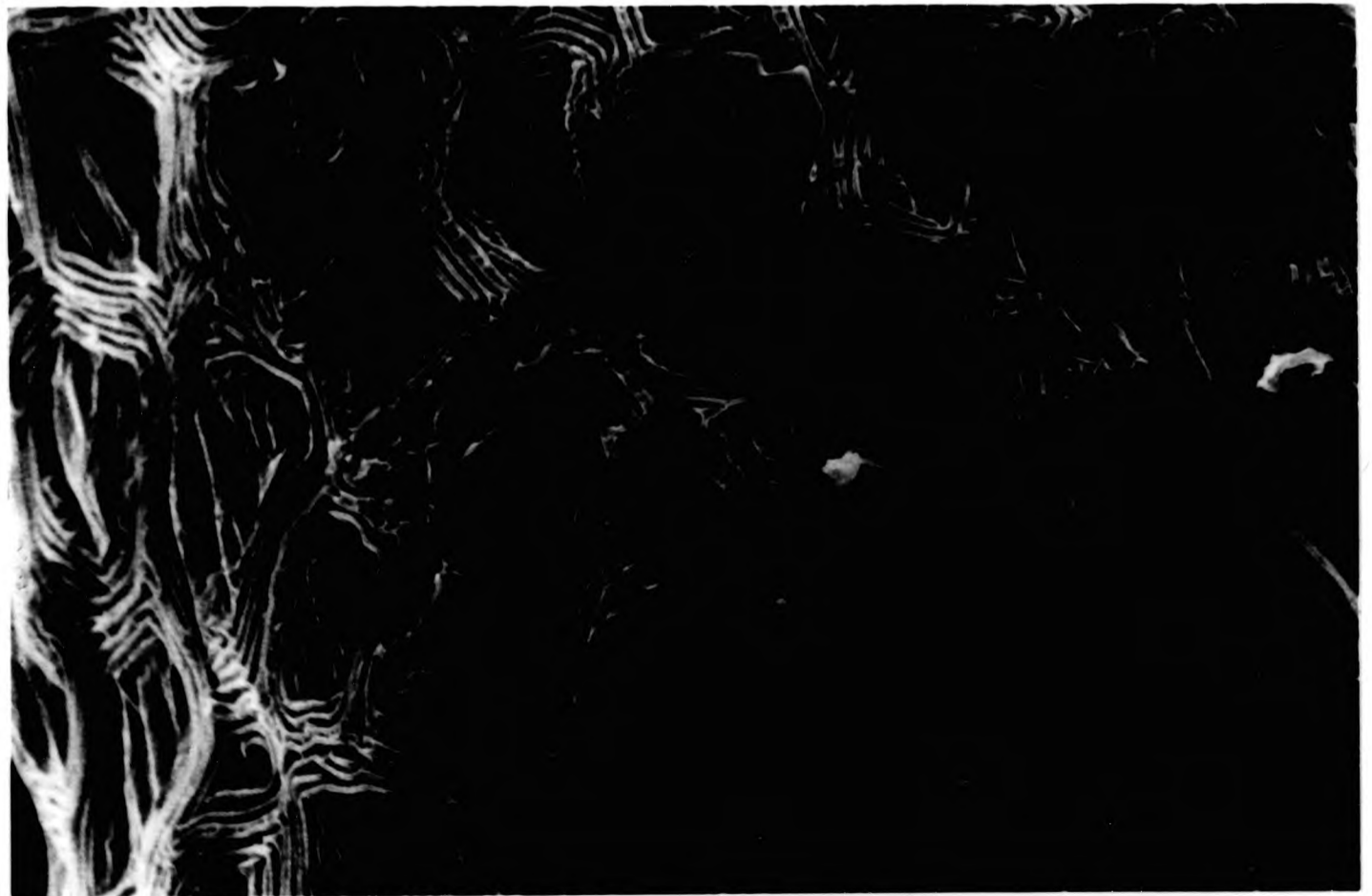

secondary lamellae. Plate 22.a shows a necrotic epithelial cells breaking away completely, leaving the basement membrane in direct contact with the water current. Lamellae thus appear to consist solely of contracted pillar cells and their flanges, covered by a thin sheet of basement membrane, although this basic structure does not rupture, so blood is not lost. The damage was not restricted to the epithelia but included in the pillar cells as well. The pillar capillary network was destroyed in many secondary lamellae resulting in a continuous blood channel (Plate 22.a). In many areas, the secondary epithelium was completely stripped of lamella (Plate 18.a). Many chloride cells showed advance signs of cellular disintegration. Mucous cells not only became extremely vacuolated but also necrotic. However, unlike chronically exposed gills, the proliferative and hypertrophic responses in epithelial cells were not evident during the short-term experiments, although this cell type was also severely damaged (Plate 20.a). The primary surface epithelium totally or partially lost its microridge pattern. In many places, cells were completely devoid of surface microridges, while in other places they were partially lost.

This corresponding group of fish under HCW conditions, were considerably less affected in comparison with the above group of fish. Secondary lamellae appeared swollen and mucus clogged (Plate 18.b). SEM revealed a partial breakdown of surface microridges (Plate 20.b). However, epithelial lifting or large scale degenerative changes were absent. No epithelial damage was observed. However, changes in chloride and mucous cell numbers were conspicuous with a mild degenerative changes in chloride cells.

(e) Fish at $520 \mu\text{g Al l}^{-1}$

Fish exposed to this concentration also displayed severe tissue damages. Tissue damage was not confined in the secondary lamellae but also included primary lamellae. Damage

to the surface epithelia was found in many areas, including lifting of the epithelial layer (Plates 21.a & 19). Many chloride cells were found to bulge out between the epithelial cells (Plate 21.a). Mucous cell staining revealed extensive proliferation of the cells and their presence on the secondary lamellae (compare with Plate 17).

Plate 21

Photomicrograph showing changes in primary lamellar surface epithelium as seen by SEM

(a) Fish exposed to $520 \mu\text{g Al l}^{-1}$ for 4 days in HCW conditions

Note cell damage (arrow) and precipitated mucus on the surface but no loss of microridges.

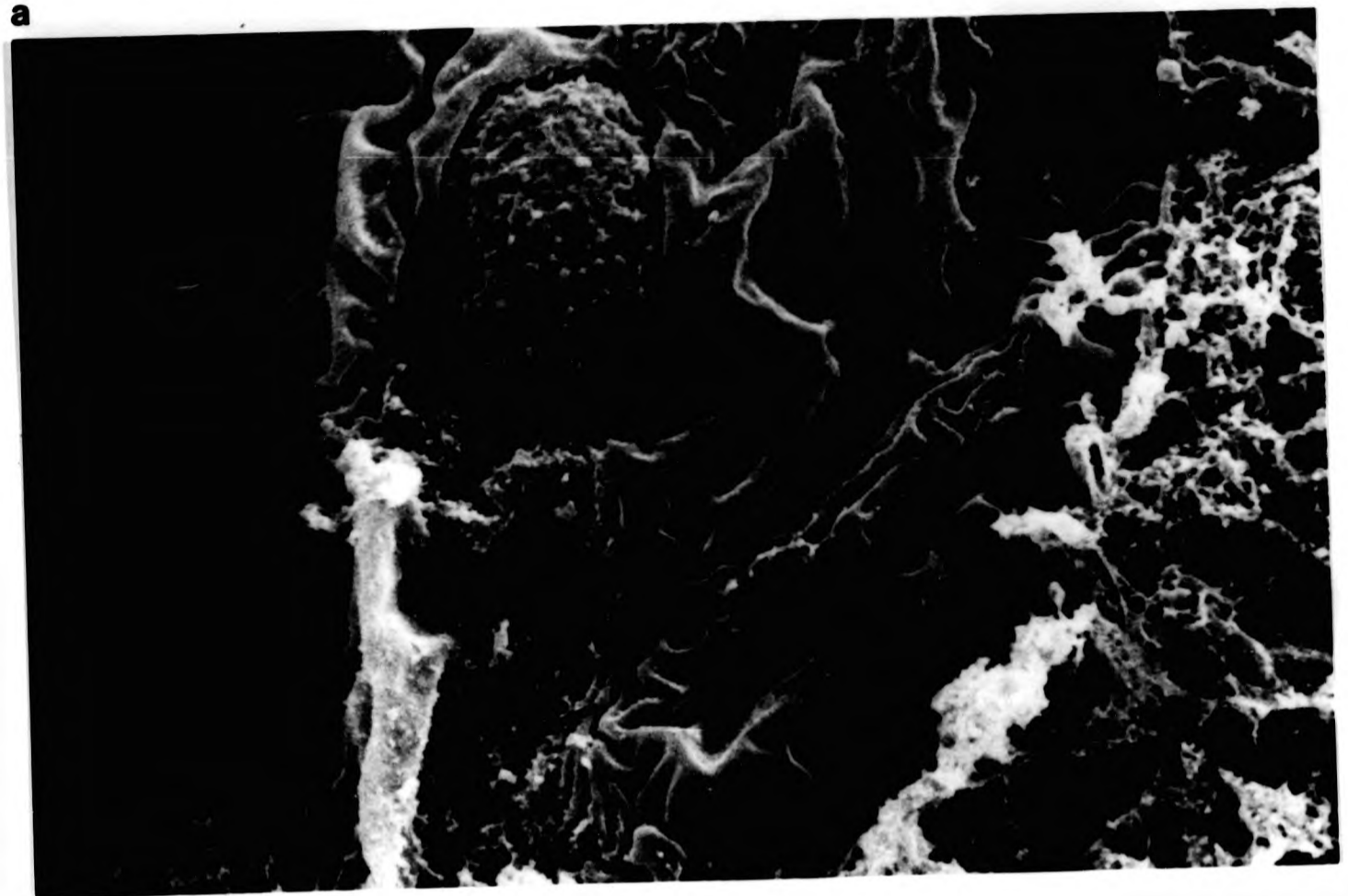

(b) Fish exposed to $120 \mu\text{g Al l}^{-1}$ for 4 days in HCW conditions

Note the surface morphology is near normal.

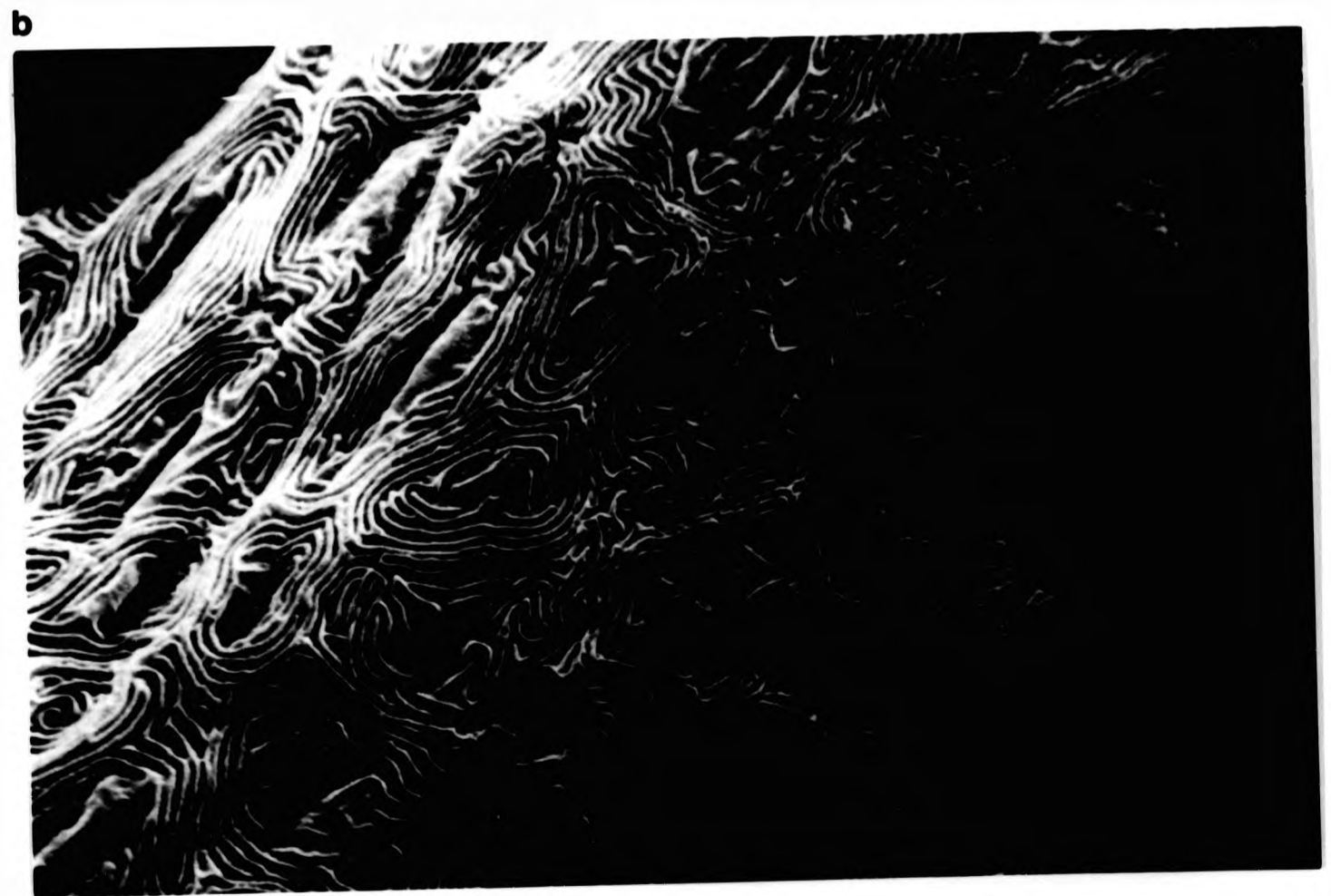

Plate 22

Photomicrographs showing the pathological changes in gills as resolved by TEM after 4 days exposure to acid/aluminium conditions

(a) A selected area on the secondary lamellae in gills exposed to $320 \mu\text{g Al l}^{-1}$ in LCW conditions

Note large intercellular vacuolation (arrow), lifting of epithelial cells (arrowhead) and breakage of pillar cells (wide arrow).



(b) A hypertrophied chloride cells from gills exposed to $220 \mu\text{g Al}$ in LCW conditions showing rupture of apical membrane. Note that the cellular organelle are intact.

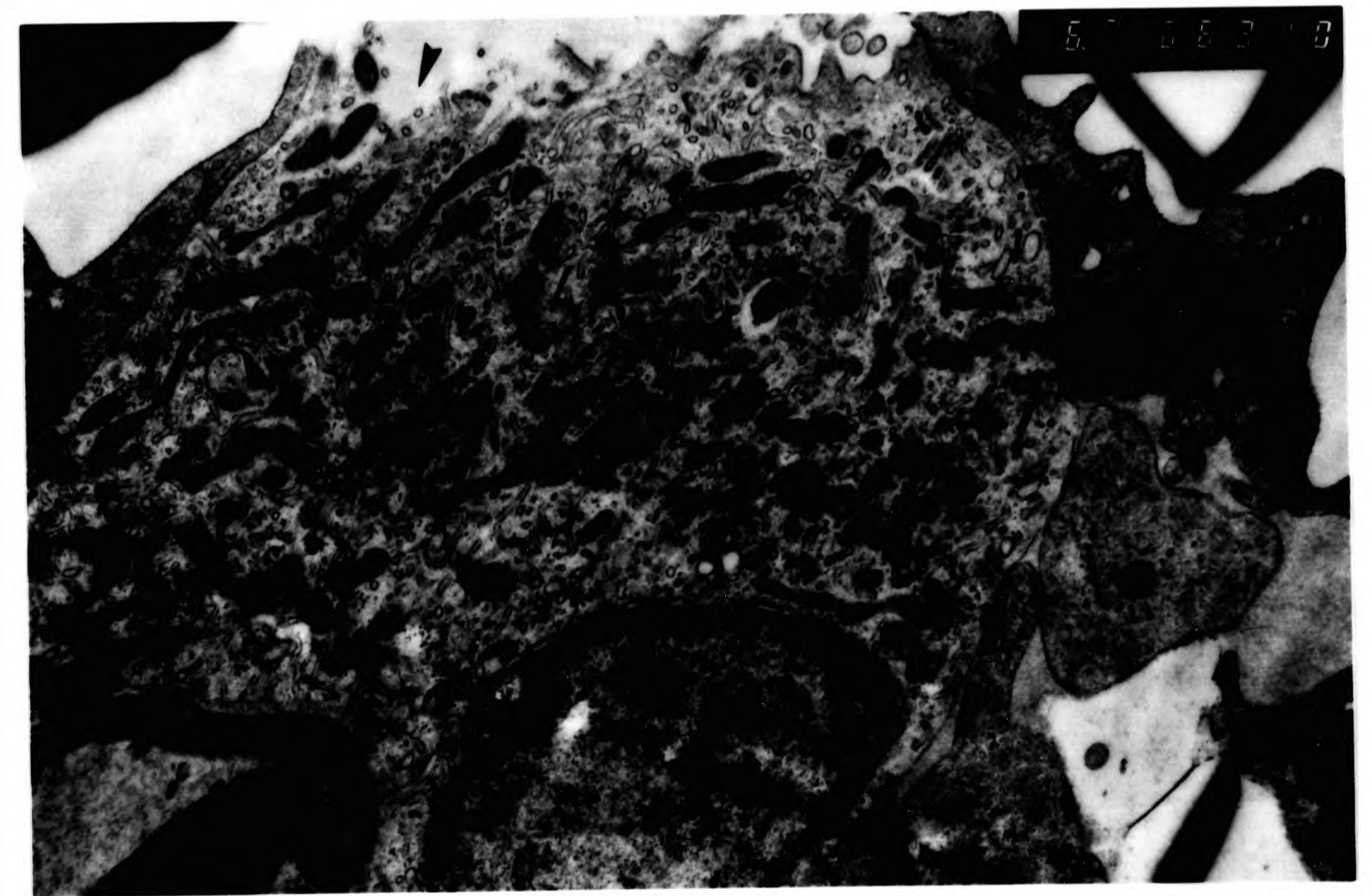

PAGINATION ERROR

235

7.4. DISCUSSION

Toxicant-induced structural changes in gill tissue may be classified into two types: one is the result of direct toxic effect of the pollutant, as cell necrosis, rupture and cell degeneration, the second is a result of compensatory mechanisms that deal with environmental stressors, as in cell proliferation in response to an osmotic challenge (Mallat, 1985). In the present study both of these types of responses were observed.

Acclimation of fish in the present study to low calcium water (LCW; 0.6 mg Ca l⁻¹) conditions resulted in chloride cell proliferation and their occurrence on the secondary lamellar epithelium, a change that was not seen in high calcium water (HCW; 16 mg Ca l⁻¹) acclimated fish or in stock fish. Consistent with the present finding, Perry and Wood (1985) also observed a substantial increase in the chloride cell population in rainbow trout, *Salmo gairdneri*, maintained in low calcium (0.025 mmol l⁻¹) environment for 7 days. Concomitant measurements of ion flux in the study of Perry and Wood revealed an increase in influx of ions under low calcium conditions. Several other studies have also shown that acclimation of fish to low calcium environments involved increases in both influx and efflux of ions (Eddy, 1975; McDonald and Milligan, 1988) and hypothesized that increase in influx was a compensatory response to higher ionic loss under low calcium conditions. Chloride cells possess the ultrastructural characteristics typical of ion-transporting cells and are known to be involved in ion transport across the gill epithelium (Bomancin and Maetz, 1982; Evans, 1982; Pang, 1983; Perry and Wood, 1985;). Thus, the proliferation of chloride cells observed in the present study in LCW acclimated fish is most probably a compensatory response to increased ionic loss under LCW conditions.

Exposure of fish to pH 5.2 in the present study did not produce any noticeable changes

in the gill structure compared with fish maintained at pH 6.8. Evans *et al.* (1988) also could not demonstrate any remarkable changes in gills except slight hypertrophy, in rainbow trout exposed to pH 5.2. The apparent lack of gill lesions under acidic conditions in the present study thus appears to be consistent with the physiological data (Chapter 4 to 6) obtained during the course of this study.

The characteristic pathological changes that were associated with tilapia gill tissue following acid/aluminium exposure included: hypertrophy, mucous and chloride cell proliferation, cell necrosis, epithelial lifting, loss of microridges, and intra-cellular and intercellular vacuolation. However, the severity and manifestation of these gill lesions were dependent upon ambient calcium and aluminium concentrations, and exposure duration. While the majority of the changes were absent in fish exposed to lower aluminium concentration, the present discussion is mainly based on the typical (characteristic) aluminium poisoning of the gill tissue observed in the present study.

The most conspicuous changes in gill histology were noted in chloride cells. Four major distinctive changes involving chloride cells were found to be influenced by acid/aluminium exposures: a) increases in number in chloride cells (visual estimate), b) occurrence of chloride cells on the secondary lamellae, c) increased abundance of chloride cells with apical pits, and d) increases in cell size and activity (hypertrophy) leading to cell death (necrosis). As discussed above, chloride cells are involved in ion uptake in freshwater fish, a proliferation and hypertrophy of chloride cells are indicative of increased uptake of ions and are probably compensatory responses to increased loss of ions from the body in acid/aluminium environment. Acid/aluminium-induced losses of body ions have been demonstrated in numerous studies, including the present one (see Chapters 1 & 3). It is also possible that hypertrophy and proliferation of chloride cells may partly be associated with expulsion of unwanted chemicals (like aluminium)

from the body, as was suggested by Mathissen and Brafield (1973) in the case of zinc-exposed sticklebacks, *Gasterosteus aculeatus*. The increase in chloride cell number and their presence in the secondary lamellar epithelium were also reported from brown trout, *S. trutta* (Karlsson-Norrgren *et al.*, 1986b), brook trout, *S. fontinalis*, (Tietge *et al.*, 1988) and rainbow trout, *S. gairdnerii*, (Neville and Youson, 1987; Evans *et al.*, 1988) during acid/aluminium exposure under laboratory conditions. Similar changes in chloride cell number, their distribution and morphology have frequently been reported in studies under varieties of circumstances other than exposure to aluminium (Mathissen and Brafield, 1973; Smart, 1975; Oronsaye and Brafield, 1984; Pottinger *et al.*, 1984; Wendelaar Bonga and Dederen, 1986). All the above studies have emphasized the sensitivity of the reaction and the significance of ionic and osmotic disturbances at the gill surface caused by various chemicals.

The observed proliferation and occurrence of chloride cells in the secondary lamellar epithelia may be a response to increase the lamellar thickness and absorptive surface in the face of osmotic challenge. It is not known whether aluminium can directly stimulate chloride cells to proliferate. However, the control is more likely to be hormonal. The above view is supported by the work of Perry and Wood (1985) who observed an increase in chloride cell population after cortisol treatment of rainbow trout and thus elevated levels of cortisol reported from acid/aluminium-exposed fish (see Chapter 1; Section 1.4.1.4) may be involved in chloride cell proliferation observed in the present study.

The apical surface of chloride cells of the stock and HCW acclimated fish was typically flat or slightly convex having a few short micro-villi as resolved by SEM. Apical pits were rare, and if present, were shallow. Fish exposed to aluminium had large number of chloride cells with well defined apical pits. Previously, the changes in morphology

of chloride cells from an unpitted to a pitted condition has been demonstrated in fish from acid waters (Leino and McCormick, 1984). The above authors suggested that pits increase the surface area for the exchange of ions or other substances. Another suggestion may be that they (pits) provide a micro-environment different from the more exposed epithelial surface.

All the above noted changes in chloride cells probably signify a complex ion-regulating ability of the cells under situations of acute osmotic stress and thereby maintenance of the milieu interior of the fish. However, necrotic changes including cytoplasmic vacuolation, dissolution of nuclear membrane and degeneration of mitochondria in the chloride cells are probably the direct results of toxic effects of aluminium. It also seems likely that increased activity following exposure to acid/aluminium sustained over time may also lead to the biochemical and physiological degradation of the cell organelle, finally resulting in cell death. Previous works concerning acid/aluminium toxicity also noted some degenerative changes in chloride cells (Youson and Neville, 1987; Jagoe *et al.*, 1987). Necrotic changes in the gill epithelium are often reported phenomena (reviewed by Mallat, 1985), particularly affecting chloride cells (Skidmore and Tovel, 1972; Karlsson-Norrgren *et al.*, 1985).

In the present study, the proliferation and hypertrophy of mucous cells, and their occurrence on the secondary lamellae were another set of changes associated with acid/aluminium exposure. The response in mucous cells were consistently observed in all aluminium exposure conditions, although the changes were more predominant at the higher aluminium concentrations. In the literature no specific reports are available on the effects of aluminium on mucous cells in fish gills, although a number of studies have recorded excessive mucus production under aluminium exposure conditions (see Chapter 1 and 3). However, mucous cell density, their size, distribution and activity

have been shown to be influenced by various chemical pollutants, including zinc (Mathissen and Brafield, 1973), cadmium (Mohan, 1990), ammonia (Smart, 1976; Lakshmikantham, 1989) and by other agents (Pottinger *et al.*, 1984; see also Mallat, 1985, for a review).

Under normal circumstances, mucus secretion is probably involved with osmoregulation and defense mechanism of fish (Pottinger *et al.*, 1984; Mallat, 1985; Handy and Eddy, 1989a; 1989b). Under conditions of toxicant exposure mucous cell proliferation has primarily been interpreted as a defense response of fish (Morgan and Tovel, 1973). Since aluminium acts as an irritant and causes inflammation to surfacial tissue (Tandjung, 1982; Wood and McDonald, 1987 and Playle *et al.*, 1989), increased production of mucus probably bar the contact of aluminium with surfacial tissue (Mallat, 1985). Mucins, which are often polyanionic, may also be specially effective at trapping metal cations and preventing such toxicants from crossing the gill epithelium (Skidmore, 1964). The thick film of mucus on the surface of the gills at the same time may reduce the passive loss of ions. The observed sloughing of precipitated mucus and its replacement by fresh mucus probably necessitates continuous increased production of mucus. Such a demand in mucus production, in turn, may trigger mucous cell proliferation and their hypertrophication. However, whatever the benefit of mucus production, the excess mucus on the gill surface can interfere with or hinder gas exchanges.

In the present study, the early profuse mucus secretion seen in the case of fish exposed to high levels of aluminium might represent an initial defense response, whereas the cellular changes noted at the later stage of exposure, wherein the mucus cells became exhausted and necrotic (vacuolation and cellular degradation), were mostly a consequence of continued aluminium exposure and cellular damage. Exhaustion of

mucus reserves may also result from excessive mucus production in fish at the higher aluminium concentrations. Such metabolic over-activity might have resulted in a tremendous strain on cellular functions, ultimately resulting in cellular and physiological degradation. It is also possible that aluminium interferes with mucous cell metabolism. Mucous cell vacuolation, exhaustion and cellular degradation have been reported as a consequence of exposure to heavy metals (Mathissen and Brafield, 1973; Kumar and Pant, 1981).

Unlike chloride cells, the proliferative changes in mucous cells were rapid. Histochemical observations made in the present study showed that mucous cells which occurred along the secondary lamellar epithelium in aluminium-exposed fish were mostly strongly PAS positive, indicating production of mucus of special chemical nature. The significance of this proliferation of specialized mucous cells during acid/aluminium exposure is unclear.

Another predominant gill lesion associated with high acid/aluminium exposure was the increased occurrence of intercellular spaces in the secondary lamellar epithelium. Similar observations have also been made by Karlsson-Norrgren *et al.* (1986b), Tietge *et al.* (1988) and Evans *et al.* (1988). The formation of these spaces apparently appeared to be due to the detachment of epithelial cells from the underlying basal membrane. An inflammatory reaction in the lymphatic space, as described by Brown *et al.* (1968) and infiltration of blood exudate (Skidmore and Tovel, 1972) probably contribute to the increased intercellular spaces. The appearance of extended lamellar spaces sometimes containing infiltrated cells seems to implicate a protective osmoregulatory manifestation of the gills (see Hughes and Wright, 1970; Hughes and Gray, 1972).

Hyperplasia or proliferation of epithelial cells (respiratory cells) is often a reported gill

lesion in fish exposed to various toxicant and other agents (see review by Mallat, 1985). In the present study this particular type of gill reaction was not observed during short-term experiments, however, it was clearly apparent during chronic exposure experiments, particularly during the later stages of exposures. This indicates that responses in epithelial cells require longer time period to develop and/or only develop after the chloride cells had been severely damaged. In the present study hyperplastic responses were not uniformly observed in the entire lamellae and were predominantly observed in areas on the gills where the secondary lamellae were found to be fused. A few studies concerned with acid/aluminium exposure (Scofield and Tronjar, 1980; Saleh, 1986; Evans *et al.*, 1988) have also mentioned hyperplastic response in gills. However, it is not clear whether such description of hyperplasia included all proliferative cell types.

Another consequence of acid/aluminium exposure was the partial or total loss of surface microridges in gills, particularly in fish exposed to higher aluminium concentrations. While no evidence was produced Karlsson-Norrgren *et al.* (1986b) mentioned changes in microridge pattern in brown trout exposed to acid/aluminium conditions. Similar changes in microridges on the surface epithelium have also been reported under variety of environmental conditions other than aluminium (review: Mallat, 1985; see also Karlsson-Norrgren *et al.*, 1985; Hocut and Tinley, 1986). The suggested causes of disappearance or breakdown of microridge pattern include oedematous changes in gill tissue and/or an increase in cell size (Karlsson-Norrgren *et al.*, 1985; Karlsson-Norrgren *et al.*, 1986b). In addition, mechanical abrasion of the epithelial surface by aluminium may also have contributed to the disappearance of microridges.

At least three possible functions of microridges have been suggested (Hughes, 1979), namely that they anchor the mucous film, that they increase the functional area and that

they produce microturbulence, enhancing the effectiveness of the exchange processes over the epithelia. A partial or total loss of microridges observed in the present study is likely to diminish the capacity for gas exchange by reducing both the lamellar area and microturbulence. The changes in microridges may also affect the retention of the mucous layer on the epithelial surface. In addition to its other functions, the surface mucus also protects gill epithelia against both mechanical abrasion and infection (Olson and Fromm, 1973). Furthermore, as stated above, the mucus layer creates a microenvironment which may act as an ion trap, concentrating ions from water and thereby helping ionic regulation (Part, 1983). Therefore, absence of mucous layer from the cell surface may disturb the osmoregulatory functions and simultaneously render the fish gill in direct contact with toxicant and thereby paving the way for greater tissue damage.

The histopathological changes noted in tilapia exposed to acid/aluminium under HCW conditions were less severe, particularly in terms of lifting and surface epithelial damage, than those were observed in LCW conditions. This protective action of external calcium concentrations on aluminium-induced gill damage is consistent with the protection afforded by calcium on physiological parameters in the present study and in the study of others (see Chapter 1). The present results also showed that higher aluminium concentrations were required in HCW conditions to obtain a similar histological response observed in LCW fish and this finding apparently agrees with the observations made by Evans *et al.* (1988). The latter author found that twice the aluminium was required in hard water to elicit a similar soft water tissue response. It is not clearly understood how external calcium reduces the gill damage caused by aluminium. However, the following explanation may be offered. It is well known that calcium is important in cell adhesion, the divalent calcium ions being thought to make cross links with calcium receptors on two adjacent cell membranes (see Chapters 1 &

8; 1.6). Those cell structures with less surface-bound calcium ions are more liable to epithelial damage by external toxicant (Hughes, 1976; McDonald, 1983b). Furthermore, since secreted mucus is frequently sloughed off under LCW conditions (see Chapter 3), the gill surface become frequently exposed to uncontrollable amounts of aluminium which may thus cause more damage to gills under LCW conditions.

Although the necrotic changes or epithelial changes were absent in fish at lower aluminium concentrations even after prolonged exposure, the proliferative and hypertrophic responses were evident under those exposure conditions, suggesting that probably the fish maintain their internal homeostasis at the higher metabolic cost.

In summary, the exposure of tilapia to acid/aluminium caused morphological changes that are consistent with the physiological observations made in this study and in the studies of others (see Chapter 1). The gill lesions recorded and described here have also been noted with other pollutants (see Mallat, 1985; for a review). Therefore, no specific lesion type can be attributed to acid/ aluminium exposure only.

CHAPTER 8
GENERAL DISCUSSION

The purpose of Chapter 8 is to summarize the important findings presented in this thesis and to discuss various aspects of the experimental approaches used. This chapter also discusses various poorly understood topics in acid/aluminium toxicity and finally outlines some important areas for further investigation.

In the present study all experimental trials, except the calcium metabolism experiment (Chapter 6), were carried out under flow-through exposure conditions in synthetic water media of precisely known composition. The measured water quality parameters showed that while there was good agreement between actual and nominal water quality parameters in flow-through exposure experiments (Chapter 3-5), the toxicant concentration in the static exposure experiment (Chapter 6) was greatly reduced within a few hours of exposure. The observations made in the present study once again underline the importance of conducting experiments of this nature under flow-through exposure conditions. This scheme of exposure was also important in removing organic materials of autochthonous origin. The use of synthetic water media (prepared by adding various salts to deionized water) under flow-through conditions in the present study not only enabled the control of both chemical and physical variants as desired but also alleviated the risk of aluminium complexation with naturally occurring complexing agents associated with tap water (i.g. silicon, humic substances; see also Chapter 1) which are known to influence aluminium toxicity. As indicated in Chapter 1 (Section 1.7) that the results of some of the earlier works carried out in tap water might have been influenced by the presence of contaminants. Interpretation of the results of those works, therefore, is difficult. In this context, the results of the present study may be used with greater confidence.

Choice of qualitative media composition employed in this study has been guided by several practical considerations and are at variance with that of most of the earlier toxicological studies concerned with aluminium. Almost all previous studies on aluminium toxicity involving assessment of the influence of calcium (where calcium was a variable for assessing the effect of calcium) used chloride-salts of calcium on the assumption that ameliorative effect of calcium is the function of calcium rather than chloride (Witters, 1986; Dalziel *et al.*, 1986; Reader *et al.*, 1988; Wood *et al.*, 1988; for examples). On the other hand, studies concerned with the effect of external calcium concentration on ionoregulation and gill function employed nitrate-salts of calcium probably based on the premise that accompanying increases in chloride ions with increased calcium levels may be an additional variable (McDonald *et al.*, 1980, McDonald *et al.*, 1983; Perry and Wood, 1985, for examples). Chloride ions are known to influence the toxicity of some chemicals (e.g. nitrate ; Hasan, 1986). It has also been shown that in eggs of sea urchins, *Anthocidaris*, calcium uptake involves a co-transport of anion, probably chloride (Fujino *et al.*, 1985). In addition, chloride ions in excess probably precipitate aluminium at a higher pH (see Exley and Phillips, 1988; for a review) that can be expected at the gill micro-environment and thus may affect aluminium solubility. In the present study, therefore, nitrate-salts of calcium were chosen instead to raise the calcium concentrations in the exposure media. Similarly, sulphate ions are also known to complex with aluminium in aqueous media affecting its solubility (see Chapter 1), thereby possibly reducing aluminium bioavailability. Therefore, acidification of exposure media was carried out with nitric acid. Thus, in the present study sulphate and chloride concentrations in the exposure media were kept to minimal and constant levels under all exposure conditions. The assumption was again made throughout this study that nitrate ions had no influence on the physiological function of fish. However, available literature suggests that nitrate may exert toxic effect in fish although only at a very high concentration. For example, Westin (1974)

estimated LC50 values for Chinook salmon, *Oncorhynchus tshawytsch*, and rainbow trout, *Salmo gairdneri*, as high as 1310 and 1340 mg l⁻¹, respectively. A nitrate concentration of 96 mg l⁻¹ was tolerated by the catfish, *Ictalurus punctatus*, without affecting the growth and feeding during a 164 d exposure period (Knepp and Arkin, 1973). The nitrate levels used in the exposure media were, however, negligible. However, when this work was in progress McDonald and Milligan (1988) reported that they had found no difference in the action of chloride and nitrate-salts of calcium on the toxicity of aluminium on the physiological functions. Extension of the present study to distinguish possible anion induced changes from that of calcium, would be helpful.

Obviously, acclimation of fish to exposure media prior to experimentation is important in this type of study where fish holding and experimental water media composition differ greatly. The advantage attached to such acclimation cannot be overestimated. Although no marked differences in blood and tissue parameters were observed among stock fish, and LCW and HCW-acclimated fish (Chapter 3 & 4), it has adequately been shown that differences in enzyme activity and gill histopathology were considerable (Chapter 5 & 7) suggesting acclimation induced changes in fish. The changes in enzyme activity and gill histology (e.g. proliferation of chloride cell) naturally reflect higher ionic uptake in fish (see Chapter 5 & 7). Indeed, acclimation induced increases in sodium influx in brook trout under low calcium conditions have been reported in a previous study (McDonald and Milligan, 1988). Acclimation of rainbow trout to low calcium water resulted in a depression in plasma sodium and chloride concentrations during the initial period of acclimation but were restored to normal within a few days of acclimation (usually 5-7 days) (McDonald *et al.*, 1980) In the present study blood and tissue parameters were measured at the end of acclimation (12-14 days), and so it is not known whether any changes in these parameters occurred at the initial stage (first few days) of acclimation. Wendelaar Bonga and Flik (1982) reported that calcium

balance in tilapia, *O. mossambicus*, was re-established within two weeks of acclimation. Therefore, it was assumed that acclimation of tilapia for two weeks in the experimental water media would be sufficient. Furthermore, acclimation of tilapia provided acclimation not only to experimental water but also to the system, thus avoiding undue handling stress.

Many of the blood and tissue parameters measured in this study were found to be sensitive to acid/aluminium exposure and as secondary stress response (Mazeaud *et al.*, 1977) several of these parameters proved useful in detecting the acid/aluminum-induced stress in tilapia. As discussed in Chapter 3, the manifestation of some parameters is dependant upon responses in other parameters. Hence, proper interpretation and evaluation of their physiological significance is dependent upon consideration of the delicate interdependence of various parameters. Observations made on a large number of interrelated blood and tissue parameters in this study provided an opportunity for interpretation of the results, although this study would have been of even greater use if determination of plasma volume and enumeration on RBC number could have been made.

Response stimulation threshold concentration, as defined in this thesis, is the range of aluminum concentration below which any concentration did not bring about any significant effect in a particular measured parameter after a 4 d acid/aluminium exposure when compared with control fish maintained at circumneutral pH in the absence of aluminium (a summary table of these concentrations are provided in Table-8.1). These threshold levels appeared to be useful as indicators of sensitivity of various parameters to acid/aluminium and probably are of some use in defining a no effect level of aluminium concentration for a fish species. In the present study, threshold response concentrations had been approximated for a number of parameters. These

Table-8.1. A summary of 4-d response threshold concentration range of aluminium suggested for various blood and tissue parameters of acid/aluminium-exposed fish in LCW and HCW conditions (see Chapter 3, Section 3.3 for details).

Parameters	Threshold Concentration Range of Aluminium ($\mu\text{g l}^{-1}$)	
	LCW	HCW
Haematocrit	70-120	120-170
Plasma Glucos	70-120	120-170
Plasma Osmolality	170-220	220-320
Plasma Sodium	70-120	220-320
Plasma Poatassium	120-170	120-170
Muscle Sodium	170-220	220-320
Muscle Potassium	220-320	220-320

concentrations varied from one parameter to another. It is therefore difficult to set a particular threshold range of aluminum for the fish as a whole. From a practical point of view it would be logical to study the effects of aluminium on growth and reproduction of various life stages and ultimately that will form the basis for meaningful pollution or water quality guidelines.

It is evident from the present study and other studies that the principal effect on fish of acid/aluminium exposure is on ionoregulation. Furthermore, these disturbances arise almost exclusively from the net loss of ions at the gills and are exacerbated when environmental calcium levels are reduced (see Chapter 1). The branchial loss of ions has been attributed to a reduction of ionic uptake which probably reflects an inhibition of the branchial transport ATPases (see Chapter 1, Section 1.4.1.4)) and a large stimulation of passive ionic efflux which likely arises from an increase in the paracellular ionic permeability of the gill epithelium (see Potts and McWilliams, 1989). The extent to which either or both of the branchial ionoregulation processes are most affected would presumably be related to ambient pH, calcium and aluminium concentrations. The process by which aluminium instigates these responses is not yet clearly understood and will form a part of this discussion in relation to the present findings, drawing relevant observations from other studies.

Acute and subacute toxicity of aluminium has been correlated with aluminium association/binding at the gill surface (McDonald *et al.*, 1989; Exley and Phillips, 1988 ; reviews). Gill surface has a substantial negative charges because of the variety of anionic ligands and, as a result, will have a relatively high affinity for the cationic forms of metals and, therefore, provides sites for metal binding on the gills, including aluminium (see Chapter 1, Section 1.6). However, binding of aluminium on the gill surface is complicated by its pH-dependent speciation and solubility and has been a

subject for debate for a long time. Two general, but not mutually exclusive, theories prevail at present, the solubility and the speciation theories (see Chapter 1 for detail) to explain aluminium binding/precipitation on the gills and possible mechanisms of aluminium toxicity.

Since aluminium toxicity to aquatic biota is greatest at "intermediate pH values" i.e. in the pH range 4.5 to 5.5 (Muniz and Leivestad, 1980; Schofield and Tronjar, 1980; Baker, 1982; Fivelstad and Leivestad, 1984; Booth *et al*, 1988), there has been a tendency to interpret this response as an indication that one or more of the hydroxy-aluminum complexes, Al(OH)_x , $x=1, 2$, is the bioavailable form or toxic species of aluminium. However, the current equilibrium model of metal ion toxicity fails to confirm this view. Since all aluminium species Al^{3+} , Al(OH)^{2+} , Al(OH)^{3+} are charged, hydrophilic species are unlikely to pass lipid bilayer of biological membranes by simple diffusion and no one form can be considered more or less available for equilibration with binding sites on the membrane. It is not yet possible to predict the nature of the critical anionic groups at the gill surface, but it is possible that different binding sites are available for different species of aluminium.

The important factor in this context is the pH of the micro-environment at the gill surface. Although the gill surface is difficult to characterize chemically, it is most likely alkaline relative to the immediately adjacent interlamellar water. Factors contributing to this condition are buffering by the polyanionic mucous layer anchored to the surface (Kirschner, 1978) and excretion of ammonia in the basic form, NH_3 (Wright and Wood, 1985). Furthermore, the surface environment (extracellular fluids of the gill epithelium and by extension by intracellular fluids) will contribute to this alkalinity, since it is likely to remain close to neutrality throughout aluminium exposure under even the most acutely lethal conditions (see Wood *et al*, 1988c). Increasing pH exponentially reduces

aluminium solubility and favours the predominance of cationic aluminium-hydroxide over monomeric aluminium (Al^{3+}) within certain pH range (see Chapter 1). This factor enhances the binding of aluminium to organic ligands, the nucleation of aluminium polymers and/or the precipitation of aluminium hydroxide complexes on the gill epithelium (see Wood and McDonald, 1987). The colloidal or insoluble polymeric forms of aluminium ($\text{Al}(\text{OH})_3$) are believed to be the responsible for mechanical injuries to gills. On the other hand, the residence time for inspired water at the gill surface probably ranges from fraction of a second to few seconds (see Playle and Wood, 1990). Therefore, questions may arise whether the process of speciation or solubility changes at the gill surface are fast enough to be completed within such a short period. *In vitro* studies, however, have indicated that such changes are relatively slow (Playle and Wood, 1990). Nevertheless, the unstirred water associated with gills may provide suitable sites for nucleation and appreciable degree of over-saturation.

The binding/or precipitation of aluminium-complexes at the gill surface and resulting interactions probably set off a host of physiological and morphological reactions. First, aluminium competes for binding sites at the gill surface and binding constants predict that aluminium will displace calcium and sodium from respective binding sites (Tam and Williams, 1986; Handy and Eddy, 1989; Handy *et al.*, 1989) and that aluminium and hydrogen ion will compete for weak acid anions at the gill surface. The ability of aluminium to displace calcium and sodium in mucus has been demonstrated in both *in vivo* and *in vitro* exposure studies (Handy and Eddy, 1989; Handy *et al.*, 1989). This stripping of calcium from its binding sites (apical membrane and intercellular space) may be expected to result in changes in membrane permeability and destabilizing of the apical membrane. Removal of membrane-bound calcium in this way probably increases the permeability to outwardly diffusive ions (i.e. increased efflux) (see Wood and McDonald, 1987).

Second, aluminium-complexes on the gill surface, either bound or precipitated, act as an irritant, cause an inflammatory response and produce mucus (see Chapter 1 and 3). Aluminium has been shown to induce severe gill damage in the present study and in those of previous workers (see Chapter 7). Changes in the gills include the disappearance of gill microridges, cell necrosis, hyperplasia, hypertrophy, epithelial deformity and epithelial sloughing. These changes probably cause increased exposure of binding sites in the gills to aluminium, further gill aluminium accumulation and acceleration of ion loss. A further contributory factor in aluminium toxicity would probably be the production of excess mucus and mucus sloughing, which were predominantly and consistently observed in the present study, particularly among the higher aluminium treatment groups of fish. Mucus is rich in polyelectrolytes. In addition to its other functions, mucus has been suggested to be involved in ionic regulation probably by creating a ionic concentration gradient between ambient media and fish body (see *Handy et al.*, 1989). Sloughing of mucus /or exhaustion of mucous reserves may not only destroy this gradient but also expose the gills to uncontrollable aluminium.

Third, aluminium probably interacts with enzyme, proteins and enzyme co-factors and may, therefore, alter their functional activities (see Trapp, 1986; for review). The exact nature of interaction in fish gills is unknown though likely association would be with calmodulin in mucus, carboxylate and thiol ligands on membrane proteins (Exley and Phillips, 1988; for review), phospholipids in apical membranes (Haug and Caldwell, 1985) and ATPase enzymes (this study and Staurnes *et al.*, 1984a; 1984b). Calmodulin has been identified in the mucus surrounding the gill lamellae (Flik *et al.*, 1982) and is likely to be involved in membrane permeability (You-Han, 1986). Activation of calmodulin requires calcium binding at specific sites. Binding with aluminium may change the conformation of calmodulin resulting in the inhibition in its function.

Aluminium-induced inhibition in Na^+/K^+ -ATPase activity was confirmed in *in vitro* experiments in the present study and also in the study of Riedel and Christensen (1979). However, the *in vivo* action of aluminium exposure on this enzyme is not clear. Both stimulatory and inhibitory responses were observed in the present study, although a certain amount of caution should be exercised before drawing any inference from the results. As the enzymes involved are believed to be situated on the baso-lateral membranes of the epithelial cells, the aluminium ions, whatever the species, must cross the apical membrane or penetrate the intercellular junctions. It is likely that aluminium would complex other organic molecules before it can reach the enzyme molecules. Therefore, the observed inhibition in enzyme activity by aluminium remains a question: whether inhibition is a result of direct or indirect action of aluminum. In fact, the inhibition in enzyme activity was observed in those fish that were very weak and severely stressed. It is not known whether such an inhibition in fish is simply a reflection of reduced metabolic activity. Simultaneous measurements of metabolic activities through the estimation of oxygen consumption and gill enzyme activity and/or adenylate energy charge (AEC) (which will indicate the energy status of the gill) may remove this confusion. Future work on this aspect would be rewarding.

The important role of ambient calcium concentration in ameliorating the effects of acid/aluminium exposure by reducing ion loss as reported in earlier studies was again demonstrated in the present study. This protective action of calcium on acid/aluminium toxicity has been shown in terms of reduced netflux (Booth *et al*, 1988) caused primarily by a reduction in passive efflux (Dalziel, 1986; Booth *et al*, 1988; McDonald and Milligan, 1988) resulting from a reduction in gill permeability (see McWilliams and Potts, 1978; Potts and McWilliams, 1989). Dalziel (1985) found that calcium ions in the exposure media had no effect on aluminium speciation in the exposure media and further suggested that the ameliorating effect of external calcium on physiological

disturbances caused by aluminium are physiological in nature rather than chemical. The protective action of calcium is thought to arise from weak anionic interaction between calcium, aluminium and surface ligands (membrane integral and peripheral proteins, mucopolysaccharides, anionic residues in intercellular spaces).

The importance of external calcium ions on the branchial ionoregulation was reviewed in some detail in Chapter 1. It will be recalled here that calcium ions stabilize apical membranes and increase the tightness of intercellular junctions, thereby maintaining gill permeability to ions. Reducing the external calcium has been shown to increase the passive permeability of ions. It is possible that gills may have different binding affinities in different external calcium concentrations and that this may explain why an increase in calcium concentration protects against ionic loss.

As discussed earlier (above), in the process of gill binding, aluminium probably displaces bound calcium from the gill ion transport channels (apical membrane and intercellular spaces) and thereby destabilizes apical membranes and opens up intercellular junctions. The action of higher calcium levels in the media under these circumstances would be to help close paracellular channels, thereby decreasing ion loss. It is probable that the relative binding capacity of calcium and aluminium depends on the molar ratios of the two ions. Therefore, a greater abundance of calcium ions may reduce the number of aluminium ions successfully binding and in this way external calcium may overcome the stripping of membrane bound calcium by aluminium thus maintaining membrane integrity. This may be a contributing factor to reduced toxicity of fish in the presence of calcium.

Another possible means by which ion loss could be reduced is by the action of external calcium in the protection of gills from damage by aluminium. Structural damage to gills

has been implicated as one of the reasons for increased efflux during acid/aluminum exposures (Wood and McDonald, 1987; Booth *et al.*, 1988; Wood *et al.*, 1988a). The present study has clearly shown that gill damage was considerably higher under low calcium water exposures (Chapter 7). However, in the same exposure trials no differences in gill aluminium accumulation were observed and thus the gill damage could not be correlated with gill aluminium accumulation (see Chapter 3, 4 & 7). Since low calcium concentrations in the external environment destabilizes cellular and membrane integrity (see above) of the epithelial cells, it is most likely that such a situation will render gill tissue more susceptible to general epithelial damage by a surface active toxicant (see McDonald *et al.*, 1983). Increasing calcium levels in the external media, therefore, would help to reduce gill damage.

As well as being able to lessen passive sodium loss caused by aluminium, calcium also appears to help in overcoming the inhibition of sodium uptake caused by aluminium as evidenced by enzyme activity measurements in the present study. Again, uncertainty surrounds the observed enzyme activity in the present study. It is not known whether the observed reduction in the inhibition of enzyme activity under LCW is related to metabolic activity or to the interaction of calcium ions with the enzyme molecule and aluminium ions.

The most contributory aspect of the present study is the observations made on calcium metabolism. Depletion of calcium reserves in scales due to low calcium and acid/aluminium exposure may have adverse effects at the population level. Reabsorption of skeletal material is known to occur during several physiological processes e.g. starvation (Yamada, 1956), sexual maturation (Mugyia and Watabe, 1977) and fracture repair (Moss, 1963). It is also known that reabsorption occurs in order to maintain calcium homeostasis under adverse conditions (Dacke, 1979). Prior depletion of calcium

reserves due to low calcium or acid/aluminium stress can affect the availability of calcium necessary for such processes. For example, the reabsorbed calcium during sexual maturation is mainly used in vitellogenesis. Insufficient calcium, as observed by Beamish *et al.* (1975) in white sucker in an acidic lake and by Mount *et al.* (1988a) in acid/aluminium exposed fish during laboratory experiments, may result in insufficient yolk or yolk with insufficient calcium. This could ultimately affect fecundity of the species as well as early skeletal development of the offspring. The main aim of this particular experiment was to demonstrate the reabsorption of skeletal calcium and calcium dynamics in different tissue compartments. However, in order to correlate the results with reproductive success, the use of mature females and their subsequent treatment with oestrogen during the latter part of exposure may be an appropriate approach. The use of larger fish over a longer period of exposure was not possible and also would not be manageable in the existing facility. However, future research should concentrate on this.

In the present study no evidence could be found in support of specific action of aluminium. It would appear from the ionoregulatory, enzymological and histopathological observations made that the action of aluminium is mainly non-specific and general and could occur as a result of other surface active toxicants (H^+ and zinc, for example).

Although this study indicates the severe effects of aluminium at low pH on ion balance, enzyme activity, and gill structure and ultrastructure, it should be remembered in natural situation that many more factors which may be important are also present. Many trace metals become elevated in acid water and may cause additive and multiple effects (Reader *et al.*, 1988; see also McDonald *et al.*, 1988) to those of simply aluminium alone. Similarly, there may also be some chemicals which may reduce the toxic action of aluminium.

LIST OF REFERENCES

Alabaster, J. S. & Llyod, R. (1980). Water Quality Criteria for Freshwater Fish. Butterworth, London. pp. 361.

Arumugan, P. T. & Furtado, J.F. (1980). Physico-chemistry, destratification and nutrient budget of a lowland eutrophicated Malaysian reservoir and its limnological implications. Hydrobiologia, 70: 11-24.

Atchison, G. J., Henry, M. G. & Sanddleinrich, M. B. (1987). Effects of metals on fish behaviour: a review. Env. Biol. Fish. 18: 11-25.

Audet, C., Munger, R. S. & Wood, C. M. (1988). Long-term sublethal acid exposure in rainbow trout (*Salmo gairdneri*) in soft water: effects on ion exchanges and blood chemistry. Can. J. Fish Aquat. Sci., 45: 1387-1398.

Avella, M., Masoni, M. Bomancin, M. & Mayer-Gostan, N. (1987). Gill morphology and sodium influx in the rainbow trout (*Salmo gairdneri*) acclimated to artificial freshwater environments. J. Exp. Zool., 241: 159-169.

Baker, J. P. (1982). Effects of metal associated with acidification. In: Proc. Symp. Acid Precip. Fish Impacts in N. E. N. America (R. E. Johnson; ed.), pp. 165-180. American Fisheries Society, Bethesda, MD.

Baker, J. P. & Schofield, C.L. (1982). Aluminium toxicity to fish in acid waters. Water Air Soil Pollut., 18: 289-309.

Balm, P. H. M., Lammers, A. & Wendelaar Bonga, S. E. (1987). Regulation of pituitary-interrenal activity in tilapia acclimating to low pH condition. Annals. Soc. r. Zool. Belg. 117(supplement 1): 343-351.

Balm, P. H. M. (1986). Osmoregulation in teleosts by cortisol and prolactin. Adaptation to low pH environments. Ph.D Thesis, University of Nijmegen. The Netherlands.

Balm, P. N., Gossen, Van de Rijk, S. & Wendelaar Bonga, S. E. (1988). Characterization of transport Na^+ ATPase in gills of freshwater tilapia. Evidence for branchial Na^+/H^+ (NH_4) ATPase activity in fish gills. Fish. Physiol. Biochem., 5: 31-38.

Bansal, S. K., Murthy, R. C. & Chandra, S. V. (1985). The effects of some divalent metals on cardiac and branchial Ca^{2+} -ATPase in a freshwater fish *Saccobranchius fossilis*. Ecotoxicology and Environmental Safety. 9: 373-377.

Barrit, G. J. (1982). Calcium movement across cell membrane. In: The role of calcium in Biological Systems (L. J. Anghileri & A. M. Anghileri, eds.) Vol.11 pp. 1730. C. R. C. Press, Boca Raton, Florida.

Batram, J. C. (1988). The effects of aluminium and low pH on chloride fluxes in the brown trout, *Salmo trutta*. J. Fish. Biol., 32: 937-947.

- Bayly, I. A. E., Ebsworth, E. P. & Wan, H.T. (1975). Studies on the lakes of Frazer Island, Queensland. Australian Journal of Marine and Freshwater Research, 26: 1-13.
- Beadle, L. C. (1974). The Inland Waters of Tropical Africa: An Introduction to Tropical Limnology. Longman, London. pp. 245.
- Beadle, L. C. (1981). The Inland Waters of Tropical Africa (2nd edition). Longman, London, N.Y., pp. 475.
- Beamish, R. J. (1972). Lethal pH for the white suckers, *Catostomus commersoni*. Trans. Amer. Fish. Soc., 2: 355-358.
- Beamish, R. J. & Harvey, H. H. (1972). Acidification of the La Cloche Mountain Lakes, Ontario and resulting fish mortalities. J. Fish. Res. Board Can., 29: 1131-1143.
- Beamish, R. J., Lockhart, W. L., Van Loon, J. C. & Harvey, H. H. (1975). Long-term acidification of a lake and resulting effects on fishes. Ambio, 4(2): 98-103.
- Berg, D. J. & Burns, T. A. (1985). The distribution of aluminium in the tissues of three fish species. J. Freshwater Ecol., 3: 113-120.
- Bhaskar, V. H., Reddena, P. & Govindappa, S. (1978). Effects of exposure to altered pH media on tissues proteolysis in a freshwater fish, *Oreochromis mossambica* (*O. mossambicus*) (Peters). Indian J. Exp. Biol., 16: 188-191.
- Bhaskar, M. & Govindappa, S. (1985). Physiological and metabolic patterns in muscle of Fish, *Tilapia mossambica* on acclimation to altered pH. Ambio 14(6): 349-351.
- Birchall, J. D., Exley, C., Chappell, J. S. & Phillips, M. J. (1989). Acute toxicity of aluminium to fish eliminated in silicon-rich acid waters., Nature, 338 (6211): 146-148.
- Bonguegneau, J. M. (1977). ATPase activity in mercury intoxicated eels. Experientia., 33(7): 941-943.
- Booth, C. E., McDonald, D. G., Simmons, B. P. & Wood C. M. (1988). Effects of aluminium and low pH on net ion fluxes and ion balance in brook trout (*Salvelinus fontinalis*). Can. J. Fish. Aquat. Sci., 45: 1563-1574.
- Borgstrom, E. (1971). Influence of deionized water on blood glucose and plasma sodium ion concentration in young salmon. Arch. Int. Physiol. Biochim., 19: 785-792.
- Boyd, C. E. (1979). Aluminium sulfate (alum) for precipitating clay turbidity from fish ponds. Trans. Amer. Fish. Soc., 108: 307-313.
- Boyd, C. E. (1980). Water Quality Criteria in Warm Water Fish Ponds. The University of Alabama Press, Alabama, pp 359.
- Brown, V. M. (1968). The calculation of the acute toxicity of mixtures of poisons to rainbow trout. Water Res., 2: 723-733.

Brown, V. M., Mitrovie, V. V. & Stark, G. T. C. (1968). Effects of chronic exposure to zinc on toxic and a mixture of detergent and zinc. Water Res., 2: 255-263.

Brown, D. J. A. & Sadler, K. (1989). Fish survival in acid waters. In: Acid Toxicity and Aquatic Animals (R. Morris, E. W. Tylor, G. D. Howells, D. J. A. Brown & J. A. Brown, eds.), pp. 31-44. Society for Experimental Biology Series No. 34. Cambridge University Press, Cambridge, N. Y., Sydney.

Brown, S. B., Eales, J. G., Evans, R. E. & Hara, T. J. (1984). Interrenal, thyroidal, and carbohydrate responses of rainbow trout (*Salmo gairdneri*) to environmental acidification. Can. J. Fish. Aquat. Sci., 41: 36-45.

Brown, D. J. A. (1981). The effects of various cations on the survival of brown trout, *Salmo trutta*, at low pHs. J. Fish. Biol., 18: 31-40.

Buergel, P. M. & Soltero, R. A. (1983). The distribution and accumulation of aluminium in rainbow trout following a whole lake alum treatment. J. Freshwater Ecol., 2: 37-44.

Burdick, C. J., Mendlinger, S. Pang, R.K. & Pang, P. K. T. (1976). Effects of environmental calcium on stannius corpuscles extracts on Ca²⁺-ATPase in killifish, *Fundulus heteroclitus*. Am. Zool., 16: 224.

Burrows, W. D. (1977). Aquatic aluminium: Chemistry, toxicology and environmental prevalence. Critical Review in Environ. Control, 7: 167-216.

Butler, P. J., Tylor, E. W., Capra, M. F. and Davidson, W. (1978). The effect of hypoxia on the level of circulating catecholamines in the dog fish *Scyliorhinus canicula*., J. Comp. Physiol ; 127: 325-330.

Cleveland, L., Little, E. E. Hamilton, S. J. Buckler, D. R. & Hunn, J. B. (1986). Interactive toxicity of aluminium and acidity to early life stages of brook trout. Trans. Amer. Fish. Soc., 115: 610-620.

Connerty, H. V. & Briggs, A. R. (1966). Determination of serum calcium by means of orthocresolphthalein complexone. Am. J. Clin. Pathol., 45: 290-296.

Cuthbert, A. W. & Maetz, J. (1972). The effects of calcium and magnesium on sodium fluxes through gills of *Carassius auratus* . J. Physiol., 221: 633-643.

Cuthbert, A. W., Fanelli, G. M. & Scriabine, A. (1979). Amelioride and Epithelial Transport. Urban and Schwazzeberg, Baltimore and Munich.

Dacke, C. G. (1979). Calcium Regulation in Submammalian Vertebrates. Academic Press, N. Y. pp. 222.

Dalziel, T. R. K., Morris, R. & Brown, D. J. A. (1986). The effects of low pH, low calcium concentrations and elevated aluminium concentrations on sodium fluxes in brown trout, *Salmo trutta* L. Water Air Soil Pollut., 30: 569-578.

Dalziel, T. R. K., Morris, R. Brown, D. J. A. (1987). Sodium uptake inhibition in brown trout, *Salmo trutta*, exposed to elevated aluminium concentrations at low pH.

Annals. R. Soc. r. Zool. Belg., 117. Proc. Ecophysiology of Acid Stress in Aquatic organisms; H. Witters & O. Vanderborcht, eds.) Antwerp.

Dalziel, T R. K. (1985). The effects of aluminium in low conductivity acid waters on the ionic regulation and early development of *Salmo trutta*. Ph. D. Thesis, Nottingham University. Nottingham.

Dange, A. D. (1986). Branchial Na⁺-K⁺ ATPase activity in freshwater or salt water acclimatised tilapia, *Oreochromis(Sarotherodon) mossambicus* : Effects of cortisol and thyroxine. Gen. Comp. Endocrinol., 62: 341-343.

Dange, A. D. (1985). Branchial Na⁺-K⁺-ATPase activity during osmotic adjustments in two freshwater eurihaline teleosts, tilapia , *Sarotherodon mossambica*. and *Etroplus maculatus*.. Mar. Biol., 87: 101-107.

Dentel, S. K. & Gossett, J. M. (1988). Mechanisms of coagulation of biological molecules with aluminium salts. Journal AWWA (Research and technology), 187-198.

DeRenzis, G. and Bornancium, M.(1984). Ion transport and gill ATPase. In: Fish Physiology, Vol X Part B,(W. S. Hoar and D. J. Randall eds), Academic Press, New York. pp 65-104.

Dharmamba, M., Bornancin, M. and Maetz, J. (1975). Environmental salinity and sodium and chloride exchanges across the gills of *Tilapia mossambica*. J. Physiol., Paris, 70: 627-636.

Dick, P. T. & Dixon, D. G. (1985). Changes in circulating blood cells of rainbow trout, *Salmo gairdneri* Richardson, following acute and chronic exposure to copper. J. Fish. Biol., 26: 475-481.

Dickson, W. (1983). Liming toxicity of aluminium to fish. Vatten, 39: 400-404.

Donaldson, E. M. (1981). The pituitary-interrenal axis as an indicator of stress in fish. In: Stress and Fish (A. D. Pickering ed), pp. 11-147. Academic Press, London, N. Y.

Donaldson, E. M. and Dye, H. M. (1975). Corticosteroid concentrations in sockeye salmon (*Onchorynchus nerka*) exposed to low concentrations of copper. J. Fish. Res. Board Can., 32:533-539.

Doneen, B. A.(1981). Effects of adaptation to sea water , 170% sea water and to fresh water on activities and sub cellular distribution of branchial Na⁺/K⁺- ATPase, low and high affinity Ca⁺ ATPase, and ouabain insensitive ATPase in *Gillichthys mirabilis*. J. Comp. Physiol., 145: 51-61.

Dougan, W. K. & Wilson, A. L. (1974). The absorptiometric determination of aluminium in water; A comparison of chromogenic and the development of improved method. Analyst, 99: 413-430.

Driscoll, C. T., Baker, J. P., Bisogni, J. J. & Schofield, C. J. (1980). Effects of aluminium speciation in dilute acidified waters. Nature, 284; 11-164.

- Drury, R. A. B. & Wallington, E. A. (eds) (1980). Carleton's Histological Techniques (5th edition). Oxford university Press. pp 511.
- Eddy, F. B. (1975). The effects of calcium on gill potential and on sodium and chloride fluxes in goldfish, *Carassius auratus*. J. Comp. Physiol., 96: 131-142.
- Edwards, A. M. C. & Thorne (1970). Observations on the dissolved solids of the Casquiane and upper Orinoco, April-june 1968. Amazoniana, 2: 245-256.
- Epstein, F. A., Katz, A. I. & Pickford, G.E.(1967). Sodium and potassium activated adenosine triphosphatase of gills. Role in adaptation to teleost. Science., 156: 1245-1247.
- Evans, D. H. (1980a). Osmotic and ionic regulation by freshwater and marine fishes. pp. 93-122. In: Environmental Physiology of Fishes (M. A. Ali. ed.), NATO Biology Series.
- Evans, D. H. (1980b). Kinetic studies of ion transport by gill epithelium. Am. J. Physiol., 238: R224-R230.
- Evans, D. H., Claiborne, J. B., Farmer, L. Malleny, C. & Krasny, E. J. (1982). Fish gills ionic transport: methods and models. Biol. Bull., 163: 108-130.
- Evans, R. E., Brown, S. B. & Hara, J. T. (1988). The effects of aluminium and acid on gill morphology in rainbow trout, *Salmo gairdneri*. Env. Biol. Fish., 22: 299-311.
- Evans, D.H. (1977). Ionic exchange mechanisms in fish gills. Comp. Biochem. Physiol., 51A: 491-495.
- Exley, C. (1989). Amelioration of Aluminium Toxicity in Atlantic Salmon L.. with particular referenced to Aluminium/Silicon Interactions. Ph. D. Thesis, Institute of Aquaculture, University of Stirling, Stirling, U. K.
- Exley, C. & Phillips, M. J. (1988). Acid Rain: Implications for farming of salmonids. In: Recent Advances in Aquaculture, vol. 3; pp. 225-341. (R. J. Roberts & J. Muir, eds.), London.
- Farnell, B. J., McLachlan, C. D. R., Baimbridge, K., De Boni, V., Wong, L. & Wood, P.L. (1985). Calcium metabolism in aluminium encephalopathy. Experimental Neurology., 88: 68-83.
- Fenwick, J.E.(1976). Effect of stanniectomy on calcium activated adenosine triphosphatase activity in the gills of freshwater adapted North American eels, *Anguilla rostrata*. Comp. Endocrinol., 29: 338-387.
- Fenwick, J.E.(1979). Ca²⁺-activated adenosine triphosphatase activity in the gills of fresh water and sea water adapted eels, *Anguilla rostrata*.. Comp. Biochem. Physiol., 62B: 67-70.
- Fenwick, J. C. & Wendelaar Bonga, S. E. (1982). Hormones and osmoregulation: endocrine involvement in calcium regulation in teleost. In: Exogeneous and Endogeneous Influences on Metabolic and neural control, Vol. 1, pp. 339-350 (A. D.

Addink & N. Spronk eds.). Oxford: Pergamon.

Feterius, W. A. (1965). A serum glucose method without protein precipitation. Am. J. Med. Technol. 30: 17.

Fishelson, L. (1980). Scanning and transmission electron microscopy of squamose gill filament epithelium from fresh- and seawater- adapted tilapia (*Tilapia mossambica*). Env. Biol. Fish., 5: 161-165.

Fiske, C. & Subbarow, K. (1925). The colorimetric determination of phosphorus. J. Biol. Chem., 66: 375-400.

Fivelstad, S. & Leivestad, H. (1984). Aluminium toxicity to Atlantic salmon (*Salmo salar* L.), and brown trout, (*Salmo trutta*): Mortality and physiological response. In: Institute of Freshwater Research; Dronningholm, Rep. No. 61, 1984 (B. Ericsson, ed), pp. 69-78.

Flemming, W. R. (1974). Electrolyte metabolism of teleosts- including calcified tissues. In: Chemical Zoology, vol. VIII., pp. 471-508 (M. Florkin and B. Scheer, eds). Academic Press, N. Y., London.

Flemming, W. R., Brehe, J. & Hanson, R. (1973). Some complicating factors in the study of the calcium metabolism of teleosts. Amer. Zool., 13: 793-797.

Flik, G., Wendelaar Bonga, S.E. & Fenwick, J.C. (1983). Ca²⁺ dependent phosphatase and ATPase activities in eel gill plasma membranes 1. Identification of Ca²⁺ activated ATPase activities with non specific phosphatase activity. Comp. Biochem. Physiol. 76B: 745-754.

Flik, G. and Wendelaar, S.E. (1984a). Ca₂₊ dependent phosphatase and Ca²⁺ dependent ATPase activities in plasma membranes of eel gill epithelium III. Stimulation of branchial high affinity Ca²⁺ ATPase activity during prolactin-induced hypercalcemia in American eels. Comp. Biochem. Physiol., 79B(4): 321-524.

Flik, G. J., Van Rus & Wendelaar Bonga, S. E. (1984b). Evidence for the presence of calmodulin in fish mucus. Env. J. Biochem., 138: 651-654.

Flik, G., Fenwick, J. C., Kolar, Z, Mayer-Gostan, N. & Wendelaar Bonga, S. E. (1985). Whole body calcium flux rates in cichlid teleost fish, *Oreochromis mossambicus* adapted to freshwater. Am. Z. Physiol., 249 (Regulatory Integrative Comp. Physiol, 18): R 432-R437.

Flik, G., Rijs, J. H. & Wendelaar Bonga (1985). Evidence for high Ca²⁺-ATPase activity and ATP-driven calcium transport in membrane preparations of the gill epithelium of the cichlid fish, *Oreochromis mossambica*. J. Exp. Biol., 119: 335-347.

Flik, G. J. Fenwick, J. C., Kolar, Z., Mayer-Gostan, N. & Wendelaar Bonga, S. E. (1986). Effects of low ambient calcium levels on whole body calcium flux rates and internal calcium pools in the freshwater cichlids teleost, *Oreochromis mossambicus*. J. Exp. Biol., 120: 249-264.

- Fraser, G. A. & Harvey, H. H. (1982). Elemental composition of bone from white suckers, *Catostomus commersoni*, in relation to lake acidification. Can. J. Fish. Aquat. Sci., 39: 1289-1296.
- Freeman, R. A. & Everhart, W. H. (1971). Toxicity of aluminium hydroxide complex in neutral and basic media to rainbow trout. Trans. Amer. Fish. Soc., 4: 644-658.
- Fugli, K. & Vislie, T. (1980). Physiological responses to acid water in fish. 1. Effects from changes in plasma osmolality and ionic concentration on heart ventricle water content & intracellular concentrations of potassium, taurine in the brown trout (*Salmo trutta* L.). In: Proc. Int. Conf. Ecol. Impact Acid Precip., (D. Drablos & A. Tollan, eds.), Mysen, Norway. Johs. Gresfile Press A/S.
- Fugelli, K. & Vislie, T. (1982). Physiological responses to acid water in brown trout (*Salmo trutta*): cell volume regulation in heart ventricle tissue. J. Exp. Biol., 101: 71-82.
- Fujino, Y., Mitsunaga, K., Fujiwara, A. & Yasumasu, I. (1985). Inhibition of $^{45}\text{Ca}^{2+}$ uptake in the eggs and embryos of sea urchin, *Anthocardaris crassispina*, by several calcium antagonists, anion transport inhibitor, and chloride transport inhibitors. J. Exp. Zool., 235: 281-288.
- Ghijsen, W. E. M., De Jong, M. D., and Van, O. S. H. (1980). Dissociation between Ca^{2+} ATPase and alkaline phosphatase activities in plasma membrane of rat duodenum. Biocem. Biophys. Acta., 559: 538-551.
- Giles, M. A., Majeski, H. S. & Hobden, B. (1984). Osmoregulatory and haematological responses in rainbow trout (*Salmo gairdneri*) to extended environmental acidification. Can. J. Fish. Aquat. Sci., 41: 18686-1694.
- Gindler, E. M. & King, J. D. (1972). Rapid colorimetric determination of biological fluids with methyl thymol blue. Am. J. Clin. Pathol., 58: 376-382.
- Girard, J. P. and Pyan, P. (1980). Ionic exchanges through respiratory and chloride cells in freshwater and sea water adapted teleostean: adrenergic control. Am. J. Physiol., 238: R 260- R 268.
- Glauret, A. M. (1975). Practical Methods in Electron Microscopy, Vol. 3. Part 1: Fixation, dehydration and embedding of biological specimen. North-Holland Publishing Company. pp. 201.
- Golterman, H. L., Clymo, R. S. & Ohnstad, M. A. M. (1978). Methods for the Physical and Chemical Analysis of Freshwaters. Blackwell scientific Publications, Oxford, U. K.
- Goss, G. G. & Wood, C. M. (1988). The effects of acid and acid/aluminium exposure on plasma cortisol and other blood parameters in rainbow trout, *Salmo gairdneri*. J. Fish. Biol., 32: 63-76.
- Gornall, A. G., Bardawill, C. J. & David, M. M. (1974). The physiological responses of the rainbow trout to strenuous exercise : Interactions of water hardness and environmental acidity. Can. J. Zool. 60: 3153-3164.

- Hagen, A. & Largeland, A. (1973). Polluted snow in southern Norway and the effect of meltedwater on freshwater and aquatic organisms. Environ. Pollut., 5: 45-57.
- Haines, T. A. (1981). Acidic precipitation and its consequences for aquatic ecosystems: a review. Trans. Amer. Fish. Soc., 110: 669-706.
- Handy, R.D. & Eddy, F. B. (1989). Surface absorption of aluminium by gill tissue and body mucus of rainbow trout, *Salmo gairdneri*, at the onset of episodic exposure. J. Fish. Biol., 34: 865-874.
- Handy, R. D., Eddy, F. B. & Romain, G. (1989). *In vitro* evidence for the ionoregulatory role of rainbow trout mucus in acid, acid/aluminium and zinc toxicity. J. Fish. Biol., 35: 735-747.
- Hassan, M. R. (1986). Husbandary factors affecting survival and growth of carp (*Cyprinus carpio*.) fry and an evaluation of dietary ingredients available in Bangladesh for formulation of a carp diet. Ph.D. Thesis., University of Stirling, Stirling, U.K.
- Haswell, M. S., Randall, D. J. & Perry, S. F. (1980). Fish gill carbonic anhydrase: acid-base regulation and salt transport. Am. J. Physiol., 238: R240-R245.
- Hattingh (1976). Blood sugar as an indicator of stress in freshwater fish, *Labeo capensis* (Smith). J. Fish. Biol., 10: 191-195.
- Haug, A. R. & Caldwell, C. R. (1985). Aluminium toxicity in plants: the role of root plasm membrane and calmodulin. *Frontiers of membraane Research in Agriculture Beltsvile Symposium 9*, (John, J. B., E. Berlin & P. C. Jackson, eds), pp. 359-381.
- Hem, J. D. (1968). Graphical methods for studies of aqueous aluminium hydroxide-fluoride and sulphate complex. Us Geol. Surv. Water Supply Paper No. 1827B.
- Hem, J. D. (1970). Study and interaction of chemical characteristics of natural water. US Geol. Survey Water Supply, Paper No. 1473.
- Hem, J. D., Roberson, C. E., Lind, C. J. & Poltzer, W. L. (1973). Chemical interpretations of aluminium with aqueous silica at 25°C. US Geol. Survey Water Supply, Paper No. 1827 E.
- Henrikensen, A. (1982). Susceptibility of surface waters to acidification, pp. 103-121. In: Acid Rain/Fisheries. Proc. International Symp. Acid Precip. and Fish Impact in N. E. N., Amer. Fish. Soc., Bethesda.
- Henry, M. G. and Atchison, G. J. (1979). Behavioural changes in bluegill (*Lepomis macrochirus*) as indicators of sublethal effects of metals. Env. Biol. Fish., 4: 37-42.
- Hesse, P. R. (1971). A Text book of Soil Chemical Analysis. pp 340-343. John Murray, London.
- HMSO (1969). Fish Toxicity Test. Her Majesty's Stationary Office. London, U. K.
- Hocutt, C. H. & Tinley, R. L. (1985). Changes in gill structure morphology of *Oreochromis mossambicus* subjected to heat stress. Env. Biol. Fish., 14: 107-114.

- Hootman, S.R. & Philpott, C. W. (1979). Utracytochemical localization of Na⁺/K⁺-activated ATPase in chloride cells from the gills of a euohaline teleost. Anat. Rec., 193: 99-130.
- Howells, G. D. (1983). Acid waters: The effects of low pH and associated factors on fisheries. Adv. Appl. Biol., 143-255.
- Howells, G. D., Brown, D. J. A. & Sadler, K. (1983). Effects of acidity, calcium and aluminium on fish productivity: a review. J. Agric. Food Sci., 34: 559-570.
- Howells, G. D. & Morris, R. (1989). Conclusions. In: Acid Toxicity and Aquatic Animals (R. Morris, E. W. Taylor, Howells, G D, D. J. A. Brown & J. A. Brown eds.). pp. 265-275. Society for Experimental Biology Seminar Series No. 34. Cambridge University Press, Cambridge.
- Hughes, G. M. & Wright (1970). A comparative study of ultrastructure of the water/blood pathways in the secondary lamellae of teleost and elasmobranchs tissue. Z. Zellforsch. Mikrosk. Anat., 104: 478-493.
- Hughes, G. M. (1972). Morphometrics of fish gills. Respir. Physiol., 14: 1-25.
- Hughes, G. M. & Morgan, M. (1973). The structure of fish gills in relation to their respiratory functions. Biol. Rev., 48: 419-475.
- Hughes, G. M. (1976). Polluted fish respiratory physiology. In: Effects of Pollution on Aquatic Organisms (A. P. M. Lockwood, ed), pp. 163-184. Society for Experimental Biology Seminar series 2.
- Hughes, G. M. & Gray, L. E. (1972). Dimensions and ultrastructure of toadfish gills. Biol. Bull., 143: 150-161.
- Hunn, J. B. Cleveland, L. & Little, L. E. (1987). Influence of pH and aluminium on developing brook trout in low calcium water. Environ. Pollut., 43: 63-73.
- Hunter, J. B., Ross, S. L. & Tannahill, J. (1980). Aluminium pollution and fish toxicity. Wat. Poll. Cont., 79: 413-420.
- Hutlberg, H. (1977). Thermally stratified acid waters in late winter- key factor inducing self accelerating processes which increases acidification. Water Air Soil Pollut., 7: 279-294.
- Hyat, M. A. (1978). Introduction to Biological Electron Microscopy. University park Press, Baltimore, Maryland. pp. 214.
- Hyvarinan, A. & Nikkila, E. (1962). Specific determination of blood glucose with o-toluidine. Clin. Chim. Acta. 7: 140-143.
- Ingersoll, C. G., Mount, D. R. Gulley, D. D. La Point, T. W. & Bergman, H. L. (1990a). Effects of pH, calcium and aluminium on survival and growth of eggs and fry of brook trout (*Salvelinus fontinalis*). Can. J. Fish. Aquat. Sci., 47: 1580-1592.

- Ingersoll, C. G., Gulley, D. D., Mount, D. R., Muller, M. E., Fernandez, J. D. Hocutt, J. R. & Bergman, H. L. (1990b). Aluminium and acid toxicity to two strains of brook trout (*Salvelinus fontinalis*). Can. J. Fish. Aquat. Sci., 47: 1641-1648.
- Jackim, E. (1974). Enzyme responses to metals in fish. In: Pollution and physiology of marine organisms. (F. J. Vernberg, & W. B. Vernberg, eds). Academic Press. N.Y.
- Jago, C. H., Haines, T. A. & Buckler, D. R. (1987). Abnormal gill development in Atlantic salmon (*Salmo salar*) fry exposed to aluminium at low pH. Annals. Soc. r. Zool. Belg., 117 (Supplement 1): 375-386.
- Jampol, L. M. & Epstein, F. H. (1970). Sodium potassium activated adenosine triphosphatase and osmotic regulation in fish. Am. J. Physiol., 218: 607-611.
- Jensen, F. B. & Weber, R. E. (1987). Internal hypoxia-hypercapnia in tench exposed to aluminium in acid water : effects of blood gas transport , acid-base status and electrolyte composition in arterial blood. J. Exp. Biol., 127: 427-442.
- Johnson, S. L., Ewing, R. D. & Lichatowich, J. A. (1977). Characterization of gill (Na-K) activated adenosinetriphosphatase for chinuk salmon, *Oncorhynchus tshawytscha*. J. Exp. Zool., 199: 345-354.
- Johnson, D. S. (1968). Malayan black waters. In: Proceedings of the Symposium on recent Advances in Tropical Ecology, Part 1 (R Misra & B. Gopal, eds.), pp. 303-310. Today and Tomorrow's Printers and Publishers. Faridabad, India.
- Johnson, N. M., Driscoll, C. T., Eaton, J. S., Likens, G.E. & McDowell, W. H. (1981). 'Acid Rain' dissolved aluminium and chemical weathering at Hubbard Brook Experimental Forest, New Hemisphere. Geochim. Cosmochim. Acta., 45: 1421-1437.
- Kamiya, M. and Utida, S. (1969). Sodium potassium activated adenosine triphosphatase activity in gill of freshwater , marine and euryhaline teleosts. Comp. Biochem. Physiol., 31: 671-674.
- Kanarky, K. J., Kinter, L. B. Kinter, W. B. & Stirling, C. E. (1976). Teleost chloride cells. 11. Autoradiographic localization of gill Na⁺/K⁺-ATPase in killifish, (*Fundulus heteroclitus*) adapted to low and high salinity environment. J. Cell Biol., 70: 157-177.
- Karlson, P. (1970). Introduction to Modern Biochemistry. 3rd edn. Academic Press. N.Y., London. pp. 483.
- Karlsson-Norrgren, L., Runn, P., Haux, C. & Forlin, L. (1985). Cadmium-induced changes in gill morphology of zebrafish, *Brachydanio rerio* (Hamilton-Buchanan) and rainbow trout, *Salmo gairdneri*, Richardson. J. Fish. Biol., 27: 81-95.
- Karlsson-Norrgren, L., Dickson, W, Jungberg, O. & Runn, P. (1986a). Acid water and aluminium exposure: gill lesions and aluminium accumulation in farmed brown trout, *Salmo trutta*. J. Fish Diseases, 9: 1-9.
- Karlsson-Norrgren, C., Bjorklund, I., Ljungberg, O. & Runn, P. (1986b). Acid water and aluminium exposure: experimentally induced gill lesions in brown trout, *Salmo trutta* L. J. Fish Diseases, 9: 11-25.

- Kerstetter, T. H., Kirschner, L. B. & Rafuse, D. O. (1970). On the mechanisms of sodium ion transport by irrigated gills of rainbow trout (*Salmo gairdneri*). J. Gen. Physiol., 56: 342-350.
- Kirschner, L. B. (1978). External charged layer and sodium regulation. In: Osmotic and Volume Regulation (Alfred Benzon Symposium X1. Munksgard). Academic Press, N. Y.
- Kirschner, L. B., Greenwald, L., & Kerstetter, T. H. (1973). Effect of amelioride on sodium transport across body surfaces of freshwater animals. Am. J. Physiol., 224: 832-837.
- Knepp, P. G. & Arkin, G. F. (1973). Ammonia toxicity levels and nitrate tolerance of channel catfish. Prog. Fish. Cult., 35: 221-224.
- Krane, S. M. & Potts, J. T. (1980). Skeletal remodelling and factor influencing bone mineral metabolism. In: Harrisons' Principles of Internal Medicine, 9th edition. (K. J. Ischelbecher, R. D. Adams & J. D. Wilson, eds.), pp. 824-832. McGraw-Hill International.
- Krogh, A. (1939). Osmotic Regulation in Aquatic Animals. Cambridge University Press, Cambridge.
- Kuhnert, P. M. and Kuhnert, B. R. (1976). The effects of in vivo chromium exposure on Na/K and Mg ATPase activity in several tissues of of the rainbow trout *Salmo gairdneri* Bull. Environ. Contam. Toxicol., 15: 388-390.
- Kumar, S. & Pant, S. C (1981). Histopathologic effects of acutely toxic levels of copper and zinc on gills, liver and kidney of *Puntius conchonus* (Ham.). Indian J. Exp. Biol., 19: 191-194.
- Lakshmikantham, P. K. (1989). Some aspects of ammonia toxicity on the gill pathology of carp *Cyprinus carpio* L. and trout, *Salmo gairdneri* . Ph.D. Thesis. Institute of Aquaculture, University of Stirling, U. K.
- Laussac, J. P. & Laurent, J. P.(1980). Study by NMR of interaction of aluminium nitrate with ATP. C. R. C. Acad. Sci (C). Paris, 291: 157-159.
- LeBel, O. D., Poierer, G. and Beudoin, A. R. (1978). A convenient method for ATPase assay. Anal. Biochem., 85: 86-89.
- Lee, C. and Harvey, H. H. (1986). Localization of aluminium in tissue of fish. Water Air Soil Pollut. 30: 649-655.
- Lehninger, A. L. (1972). Biochemistry, Worth, N. Y. pp. 833.
- Leino, R. L. & McCormick, J.H. (1984): Morphological and morphometrical changes in chloride cells of the gills of *Pimephelus promelas* after chronic exposure to acid water. Cell, Tissue Res., 236: 121-128.

- Lewis, W. M. Jr. & Weibezalin, F. H. (1976). Chemistry, water flow and community structure in some Venezuela freshwaters. Archiv. fur Hydrobiologia. Supplement, 50: 145-207.
- Loffler, H. (1978). Limnological and palaeolimnological data on the Bale mountain lakes (Ethiopia). Verhandlungen internationale vereinnigung fur theoretische und angewandte Limnologie, 20: 1131-1138 (cited in Serruya & Pullinger, 1983).
- Lopez, E., Peignoux-Deville, J., Lallier, F., Martelly, E. & Milet, C. (1976). Effects of calcitonin and ultimobranchialectomy (UBX) on calcium and bone metabolism in the eel, *Anguilla anguilla* L., Calcif. Tissue. Res., 20: 173-186.
- Loveshin, L. L. (1982). Tilapia hybridization. In: Proc. Int. Conf. on the Biology and Culture of Tilapia. (R.S.V. Pullin and A.R.H. Lowe- Mconnell, eds) ICLARM, Bangkok, Thailand.
- Lowry, O. H., Rosebrough, N. J., Farr, A. L. and Randall, R. J. (1951). Protein measurements with the Folin phenol reagent. J. Biol. Chem., 193: 265-275.
- Ma, S. W. Y., Shami, Y., Messer, H. H. and Copp, D. H. (1974). Properties of Ca²⁺ ATPase from the gills of rainbow trout, *Salmo gairdneri*. Biochem. Biophysic. Acta., 345: 243-251.
- Madsen, S. S. & Naamansen, E. T. (1989). Plasma ionic regulation and gill Na⁺ /K⁺ - ATPase changes during rapid transfer to sea water of yearling rainbow trout, *Salmo gairdneri*: time course and seasonal variation. J. Fish. Biol. 34: 829-840.
- Maetz, J. & Bomancin, M. (1975). Biochemical and biophysical aspects of salt excretion by chloride cells in teleosts. Fortschr. Zool., 23: 322-362.
- Maetz, J. (1974). Aspects of adaptation to hyposmotic and hyperosmotic environments. In: Biochemical and Biophysical Perspective in Marine Biology. Vol 1 (D. C. Marlins and J. R. Sargent, eds). pp. 1-152. Academic Press, N.Y.
- Maetz, J. (1971). Fish gills: mechanism of salt transfer in fresh water and salt water. Phil. Trans. Roy. Soc. London., 262: 209-249.
- Maetz, J. & Garcia-Romeau, F. (1964). The mechanisms of sodium and chloride uptake by the gills of freshwater fish, *Carassius auratus*, 2. Evidence for NH₄/Na⁺ and HCO₃⁻/Cl⁻ exchanges. J. Gen. Physiol., 47: 1209-1227.
- Maetz, J. (1973). Na⁺/NH₄⁺, Na⁺/H⁺ exchanges and NH₃ movement across the gills of *Carassius auratus*. J. Exp. Biol., 58: 255-275.
- Mallat, J. (1985). Fish gill structural changes induced by toxicants other than irritants. A statistical review. Can. J. Fish. Aquat. Sci., 42: 630-648.
- Malley, D. F. (1980). Decreased survival and calcium uptake by the crayfish, *Oreonectes virilis*, in low pH. Can. J. Fish. Aquat. Sci., 37: 364-372.
- Malte, H. (1986). Effects of aluminium in hard, acid water on metabolic rate, blood gas tensions and ionic status in the rainbow trout. J. Fish. Biol., 29: 187-198.

- Mashiko, K., Jozuka, K. & Morita, O. (1964). Turnover of ^{45}Ca by the scales of crucian carp. Ann. Rep. Noto Mar. Lab., 4: 53-58.
- Mason, J. (1989). Introduction: The causes and consequences of surface water acidification. In: Acid Toxicity and Aquatic Animals. Society for Experimental Biology Seminar Series 34. pp 1-29 (R. Morris, E. W. Taylor, G. D. Howells, D. J. A. Brown & J. A. Brown, eds.), Cambridge University Press, Cambridge, N. Y. Sydney.
- Mathissen, P. & Brafield, A. E. (1973). The effects of dissolved zinc on gills of the stickleback, *Gasterosteus aculeatus* (L.). J. Fish. Biol., 5: 607-613.
- Mayer-Gostan, N. M., Bornancin, C., DeRenzis, R. Shew, L. & Pang, P. K. T. (1983). Extraintestinal calcium uptake in the killifish, *Fundulus heteroclitus*. J. Exp. Biol., 227: 329-338.
- Mazeand, M. M., Mazeand, F. & Donaldson, E. M. (1977). Primary and secondary effects of stress in fish: some new data with general review. Trans. Amer. Fish. Soc., 106: 201-212.
- McAndrew, B. J. and Majumdar, K.C. (1983). Tilapia stock identification using electrophoretic marker. Aquaculture., 30: 249-261.
- McComb, R. B., Bewers, G. N. & Posen, S. (1979). Alkaline phosphatase. Plenum Press, N.Y.
- McConnel-Lowe, R. H. (1975). Fish Communities in Tropical freshwaters. Longman, London. pp. 312.
- McCormick, J. H., Jensen, K.M. & Anderson, L. E. (1989). Chronic effects of low pH and elevated aluminum on survival, maturation, spawning and embryo-larval development of the fathead minnow in soft water. Water Air Soil Pollut., 43: 293-307.
- McCormick, J. (1990). The Third World- pollution and development. In: Acid Earth. pp. 192-220. Earthscan Publishing Limited, London.
- McDonald, D.G. (1983a). The interactions of environmental calcium and low pH on the physiology of the rainbow trout, *Salmo gairdneri*. 1. Branchial and renal net ion and H^+ fluxes. J. Exp. Biol., 102: 123-140.
- McDonald, D. G. (1983b). The effects of H^+ upon the gills of freshwater fish. Can. J. Zool., 61: 691-703.
- McDonald, D. G. & Wood, C. M. (1981). Branchial and renal ion fluxes in the rainbow trout, *Salmo gairdneri*, at low environmental pH. J. Exp. Biol., 93: 101-118.
- McDonald, D. G., Hobe, H. & Wood, C.M. (1980). The influence of calcium on the physiological responses of the rainbow trout, *Salmo gairdneri*, to environmental pH. J. Exp. Biol., 88: 109-131.
- McDonald, D. G. & Milligan, C. L. (1988). Sodium transport in the brook trout, *Salvelinus fontinalis*: effects of prolonged low pH exposure in the presence of absence

of aluminium. Can. J. Fish. Aquat. Sci. 45: 1606-1613.

McDonald, D. G., Walker, R. L., & Wilkies, P. R. H. (1983). The interaction of environmental calcium and low pH on the physiology of the rainbow trout, *Salmo gairdneri*. II. Branchial ionoregulatory mechanisms. J. Exp. Biol., 102: 141-155.

McDonald, D. G., Reader, J. P. & Dalziel, T. R. K. (1989). The combined effects of pH and trace metals on fish ionoregulation. In: Acid Toxicity and Aquatic Animals. pp 221-242. (R. Morris, E. W. Taylor, G. D. Howells, D. J. A. Brown & J. A. Brown, eds.). Society for Experimental Biology Seminar Series 34, Cambridge University Press, Cambridge, N. Y., Sydney.

McCarty, L. S. and Houston, A. H. (1977). Na^+/K^+ and HCO_3^- stimulated ATPase activities in the gills and kidneys of thermally acclimated rainbow trout *Salmo gairdneri*. Can. J. Zool., 28: 655-662.

McKeown, B.A. , Geen, G. H. , Watson, T.A. , Powell, J. F. & Parker, D. B. (1985). The effects of pH on the plasma electrolytes, carbonic anhydrase and ATPase activities in rainbow trout (*Salmo gairdneri*) and large scale suckers (*Catostomous macrocheilus*). Comp. Biochem. Physiol., 80A: 507-514.

McKim, J. M., Christesen, G. M. & Hunt, E. P. (1970). Changes in blood in brook trout (*Salvelinus fontinalis*) after short-term and long-term exposure to copper. J. Fish. Res. Bd. Canada, 27: 1883-1889.

McLeay, D. J. (1977). Development of a blood sugar bioassay for rapidly measuring stressful levels of pulp mill effluent to salmonid fish. J. Fish. Res. Board. Can., 34: 477-485.

McMahan, B. R. & Stuart, S. A. (1985). Haemolymph and tissue ion and acid-base balance in cray fish during chronic exposure to nitric acid. Am. Zool., 25: 48A.

McMahan, B. R. and Stuart, S. (1989). The physiological problems of cray fish in acid waters. In: Acid Toxicity and Aquatic Animals (R. Morris, E. W. Taylor, G. D. Howells, D. J. A. Brown & J. A. Brown, eds.), Society for Exp. Biology Seminar Series 34, pp. 171-200. Cambridge University Press, Cambridge, N. Y. Sydney.

McWilliams, P. G. (1982). The effects of calcium on sodium fluxes in the rainbow trout, *Salmo trutta*. in neutral and acid waters. J. Comp. Physiol., 126: 277-286.

McWilliams, D. G. & Potts, W. T. W. (1978). The effects of pH and calcium concentrations in the gill potentials in the brown trout, *Salmo trutta*. J. Comp. Physiol., 126: 277-286.

Meybeck, M. (1978). Note on dissolved elemental content of Zaire river. Netherlands J. Sea Res., 12: 293-295 (cited in Serruya & Pollinger, 1983).

Milligan, C. L. & Wood, C. M. (1982). Disturbances in haematology, fluid volume distribution and circulatory function associated with low environmental pH in the rainbow trout, *Salmo gairdneri*. J. Exp. Biol., 99: 397-415.

- Moon, T. W. (1978). The characterization of ATPase from the gills of the *Osteoglossial osteoglossum bieirrhosum* (anura). Can. Z. Zool., 56:795-800.
- Moss, M. L. (1963). The biology of acellular teleost bone. Annal. N. Y. Acad. Sci., 109; 227-350.
- Mount, D. R., Hockett, J. R. & Gem, W. A. (1988a). Effect of long-term exposure to acid, aluminium and low calcium on adult brook trout (*Salvelinus fontinalis*). 2. Vitellogenesis and osmoregulation. Can. J. Fish. Aquat. Sci., 45: 1633-1642.
- Mount, D. R., Ingersoll, C. G., Gulley, D. D., Fernandez, J. D., La Point, T. W. & Bergman, H. L. (1988b). Effect of long-term exposure to acid, aluminium and low calcium on adult brook trout (*Salvelinus fontinalis*). 1. Survival, growth, fecundity and progeny survival. Can. J. Fish. Aquat. Sci., 45: 1623-1632.
- Mugiya, Y. & Watabe, N. (1977). Studies on fish scale formation and resorption-11. Effect of estradiol on calcium homeostasis and skeletal tissue resorption in the goldfish, *Carassius auratus*, and the killifish, *Fundulus heteroclitus*. Comp. Biochem. Physiol., 57A: 197-202.
- Muniz, F. P., Anderson, R and Sullivan, T. J. (1987). Physiological response of brown trout (*Salmo trutta*) spawners and post spawners to acidic aluminium-rich stream water. Water, Air and Soil Pollut., 36: 371-379.
- Muniz, I. P. and Leivestad, H. (1980). Toxic effects of aluminium on the brown trout, *Salmo trutta* L. In: Proc. Int. Conf. Ecol. Impact Acid Precip. (D. Drablos & A. Tollan, eds), pp. 320-321. Mysen, Norway, Johs. Gresfile Press A/S.
- Murthy, V. K., Reddanna, P. & Govindappa, S. (1981). Hepatic carbohydrate metabolism in *Tilapia mossmbica* (Peters) acclimated to low environmental pH. Can. J. Zool. 59: 400-404.
- Murungi, J. I. & Robinson, J. W. (1987). Synergistic effects of pH and aluminium concentrations on the life expectancy of tilapia (*mossambica*) fingerlings. J. Environ. Sci. Health, A 22(5). 391-395.
- Nakano, T. & Tomilson, N. (1967). Ctecholamine and carbohydrate concentrations in rainbow trout (*Salmo gairdneri*) in relation to physical disturbances. J. Fish. Res. Board Can., 24: 1701- 1715.
- Nelson, J. A. (1982). Physiological observations on developing rainbow trout, *Salmo gairdneri* (Richardson), exposed to low pH and varied calcium concentrations. J. Fish. Biol., 20: 359-372.
- Neville, C. M. & Campbell, P. C. (1988). Possible mechanisms of aluminium toxicity in a dilute, acidic environment to fingerlings and older life stage of salmonids. Water Air Soil Pollut., 42: 311-327.
- Neville, C. M. (1985). Physiological response of juvenile rainbow trout, *Salmo gairdneri*, to acid, and aluminium- prediction of field responses from laboratory data. Can. J. Fish. Aquat. Sci., 42: 2004-2019.

- Neville, C. M. (1979). Sublethal effects of environmental acidification on rainbow trout (*Salmo gairdneri*). J. Fish. Res. Board Can., 36: 84-87.
- Nicholls, D. G. (1982). Bioenergetics, Academic Press, London. pp. 320.
- Nieminen, M., Korhonen, I. & Laitinen, M. (1982). Effects of pH on the gill ATPase activity and blood composition of white fish *Coregonus peled*. and trout, *Salmo trutta*. Comp. Biochem. Physiol., 72A (4): 637-642.
- Nikinmaa, M. (1983). Adrenergic regulation of haemoglobin-oxygen affinity in rainbow trout red cells. J. Comp. Physiol., 152: 67-72.
- Nordstrom, D. K. (1982). The effects of sulphate on aluminium concentrations in natural waters: some stability relations in the system $Al_2O_3 \cdot SO_3 \cdot H_2O$ at 28 k. Geochim. Cosmochim. Acta., 46: 681-692.
- Norton, S. A. (1982). The effects of acidification on the chemistry of ground and surface waters. In: Acid Rain/Fisheries (R. E. Johnson, ed.), pp -163. Proc. Int. Symposium Acid. Precip. Fish. Impacts in N. E. E. America. Amer. Fish. Soc., Bethesda, MD.
- Ochiai, E. (1977). Bioinorganic Chemistry - An introduction. Boston: Allyn and Bacon, Inc; pp. 513.
- Odonnell, A. R., Mance, G. & Norton, R. (1984). A Review of Toxicity of Aluminium in Freshwater. W. R. C. Technical Report, TR 197. pp. 27.
- Ogilvie, D. M. & Stechey, D. M. (1983). Effects of aluminium on respiratory responses and spontaneous activity of rainbow trout, *Salmo gairdneri* Environ. Toxicol. Chem. 2: 43-48.
- Olson, K. R. and Fromm, P.O.(1975). A scanning electron microscopic study of secondary lamellae and chloride cells of rainbow trout, *Salmo gairdneri*. Z. Zellforsch. Mikrosk. Anat. 143: 439-449.
- Ommerod, S. J., Weatherley, N. S. French, P., Blake, S. & Jones, W. M. (1987). The physiological response of brown trout, *Salmo trutta*, to induced episodes of low pH and elevated aluminium in Welsh Hill stream. Annals. soc. r. Zool. Belg., 117 (Supplement 1): 435-447.
- Oronsaye, J. A. O. and Brafield, A. E. (1984). The effect of dissolved cadmium on the chloride cells of the gills of stickleback, *Gasterosteus aculeatus*. L. J. Fish. Biol. 25: 253-258.
- Orr, P.L., Bradly, R.W., Sprague, J. B. and Hutchinson, N. J.(1986). Acclimation induced changes in toxicity of aluminium to rainbow trout *Salmo gairdneri*. Can. J. Fish. Aquat. Sci., 43: 243- 246.
- Oschman, J. L. (1978). Morphological correlates of transport. In: Membrane Transport in Biology, vol. 111. Transport across multi-membrane systems (G. Giesbisch, D. C. Tosteson & H. H. Ussing, eds), pp. 55-84. Springer-Verlag, N. Y.

- Pang, P. K. T. (1971a). The relationship between corpuscles of Stannius and serum electrolyte regulation in killifish, *Fundulus heteroclitus*. J. Exp. Zool., 178: 1-8.
- Pang, P. K. T. (1971b). The effects of complete darkness and vitamin supplement on the killifish, *Fundulus heteroclitus*, adapted to sea water. 1. Calcium metabolism and gonadal maturation. J. Exp. Zool., 178: 15-22.
- Pang, P. K. T., Schreiber, M. P. & Griffith, R. W. (1973). Pituitary regulation of serum calcium levels in the killifish, *Fundulus heteroclitus*. Gen. Comp. Endocrinol., 21: 536-542.
- Pang, P. K. T. (1983). Evolution of control of epithelial transport in vertebrates. J. Exp. Biol., 106: 283-299.
- Parker, D. B., Mckeown, B. A. & McDonald, J. S. (1985). The effect of pH/ and calcium enriched fresh water on gill Ca^{2+} ATPase activity and osmotic water inflow in rainbow trout, *Salmo gairdneri*. Comp. Biochem. Physiol., 81A, 149-156.
- Payan, P., Mayer-Gostan, N. & Pang, P. K. T. (1981). Site of calcium uptake in the freshwater gill. J. Exp. Zool., 216: 345-347.
- Payan, P. (1978). A study of the $\text{Na}^+/\text{NH}_4^+$ exchange across the gills of the perfused trout, *Salmo gairdneri*. J. Comp. Physiol., 124: 181-188.
- Payan, P., Matty, A. J. & Maetz, J. (1975). A study of the sodium pump in the perfused head preparation of the trout, *Salmo gairdneri*, in fresh water. J. Comp. Physiol., 122: 33-48.
- Payan, P. & Girard, G. P. (1984). Branchial ion movements in teleosts: the roles of respiratory and chloride cells. In: *Fish Physiology*, vol. XB (W. S. Hoar and D. S. Randall, eds.), pp. 39-63. Academic Press, N. Y.
- Part, P. (1983). Cadmium uptake in perfused rainbow trout gills. Acta Universitatis Upsaliensis. Dissertation from the Faculty of Sciences (Cited in Karlsson-Norrgren *et al.*, 1985)
- Peirson, D.H., Cawse, P. A. & Canibray, P.S. (1974). Chemical uniformity of airborne particulate material and a maritime effect. Nature, 251: 657- 679.
- Perry, S.F. & Wood, C.M. (1985). Kinetics of branchial calcium uptake in the rainbow trout: Effects of acclimation to various external calcium levels. J. Exp. Biol., 116: 411-453.
- Pfeiler, E. and Kirschner, L. B. (1972). Studies on gill ATPase of rainbow trout, *Salmo gairdneri*. Biochem. Biophysic. Acta., 282: 301-310.
- Phillips, M. J. & Seleh, M. A. M. (1987). Aluminium toxicity to tilapias based on experiments with *Oreochromis aureus*. In: The Second International Symposium on Tilapia in Aquaculture. pp. 489-496. (R.S.V. Pullin, T. Bhukaswan, K. Tonguthai and J.L. Maclean, eds). ICLARM, Bangkok, Thailand.
- Pillai, V. K., Ponniah, A. G., Vincent, D. and Raj, T.D. (1985). Acidity in Vembanad lake causes fish mortality. Marine Fisheries Information Service, 53: 8-15.

- Plankey, B. J., Patterson, H.H. & Eronam, C. S.(1986). Kinetics of aluminium fluoride complexation in acidic waters. Environ. Sci. Technol.,20: 160-165.
- Playle, R. C. & Wood, C.M. (1990). Is precipitation of aluminium is fast enough to explain deposition on fish gills. Can. J. Fish. Aquat. Sci.,47:1558-1561.
- Playle, R. C., Goss, G. G. & Wood, C. M. (1989). Physiological disturbances in rainbow trout (*Salmo gairdneri*) during acid and aluminium exposures in soft water of two calcium concentrations. Can. J. Zool. 67: 314-324.
- Pott, D. B., Alberts, J. J. & Elzerman, A. W. (1985). The influence of pH on the binding capacity and conditional stability constants of aluminium and naturally occurring organic matter. Chem. Geol., 48: 293-304.
- Pottinger, T.G., Pickering, A.D. & Blackstock, N.(1984). Ectoparasite induced changes in epidermal cells of brown trout, *Salmo trutta* L. J. Fish. Biol., 25: 123-128.
- Potts, W. T. W. & McWilliam, P. G. (1989). The effects of hydrogen and aluminium ions on fish gills. In: Acid Toxicity and Aquatic Animals (R. Morris, E. W. Taylor, G. D. Howells, D. J. A. Brown & J. A. Brown, eds.), pp. 201-220. Society for Experimental Biology Seminar Series No. 34. Cambridge University, Cambridge, N. Y., Sydney.
- Rand, G. M. (1985). Behavior. In: Fundamentals of Aquatic Toxicology (G.M. Rand and S.R.Petrocelli (eds)). Hemisphere Publishing Corporation, Washington, N.Y., London. pp. 221-256.
- Rand, G. M., and Petrocelli, S. R. (1985). Introduction. In: Fundamentals of Aquatic Toxicology (G.M. Rand and S.R.Petrocelli, eds). Hemisphere Publishing Corporation, Washington, N.Y., London. pp. 1-28.
- Reader, J. P., Dalziel, T. R. K. and Morris, R. (1988). Growth, mineral uptake and skeletal calcium deposition in brown trout, *Salmo trutta*, yolk sac fry exposed to aluminium and manganese in soft acid water. J. Fish. Biol., 32: 607-624.
- Reader, J. P., Everall, N. C., Sayer, M. D. and Morris, R. (1989). The effects of eight trace metals in acid soft water on survival, mineral uptake and skeletal calcium deposition in yolk-sac fry of brown trout, *Salmo trutta* L. J. Fish. Biol., 35: 187-198.
- Reader, J. P. and Morris, R. (1988). Effects of aluminium and pH on calcium fluxes and effects of cadmium and manganese on calcium and sodium fluxes in brown trout, *Salmo trutta* . Comp. Biochem. Physiol., 91(2): 449-457.
- Richards, B. D. and Fromm, P. O. (1970). Sodium uptake by the isolated perfused gills of rainbow trout, *Salmo gairdneri*. Comp. Biochem. Physiol., 33: 303-310.
- Riedel, B. and Christensen, G. (1979). Effect of selected water toxicants and other chemicals upon adenosine triphosphatase activity *in vitro*. Bull. Environ. Contam. Toxicol., 23: 365-368.
- Roberson, C. E. and Hem, J. D. (1969). Solubility of aluminium in the presence of hydroxide, fluoride and sulphate. Us Geol. Surv. Water Supply Paper No 1827E.

- Roberts, R. J. (1978). *Fish Pathology* (2nd ed). Bailliere Tindal, London.
- Rodger, D. W. (1984). Ambient pH and calcium concentrations as modifiers of growth and calcium dynamics of brook trout (*Salvelinus fontinalis*). Can. J. Fish. Aquat. Sci., 41: 1774-1780.
- Rosenthal, H. L. (1956). Uptake and turnover of calcium-45 by the guppy, Science, 124: 571-574.
- Rosenthal, H.L.(1963), Uptake, turnover and transport of bone seeking elements of fishes. Ann. N.Y. Acad. Sci., 109: 278-293.
- Rosseland, B. O. (1980). Physiological responses to acid water in fish 2. Effects of acid water on metabolism and gill ventilation in brown trout, *Salmo trutta*, and brook trout, *Salvelinus fontinalis* Mitchil. In: Proc. Int. Conf. Ecol. Impact Acid Precip. (D. Drablos & A. Tollan, eds.), pp. 348-349., Norway.
- Rosseland, B. O. & Skogheim, O. K. (1982). Physiological stress and mortality of Atlantic salmon, *Salmo salar* L., in acid water with high levels of aluminium. Report for the Anandromous and Catadromus Fish Committee. International Council for the Exploration of the Sea.
- Rosseland, B. O. and Skogheim, O. K. (1984). A comparative study on salmonid fish species in acid aluminium rich water. Rep. Inst. Freshwater Res. Drottningholm, 61: 186-194.
- Ruben, J. A. and Bennet, A. F. (1981). Intense exercise and blood calcium levels in vertebrates. Nature. Lond., 291: 411-413.
- Russell, R. G. G., Bonjour, M., & Fleisch, H. (1972). Relation between alkaline phosphatase and Ca²⁺-ATPase in calcium transport. Nature, 240: 126-127.
- Sadler, K. & Lynam, S. (1987). Some effects on the growth of brown trout from exposure to aluminium at different pH levels. J. Fish. Biol., 31: 209-219.
- Sadler, K. & Lynam, S. (1988). The influence of calcium on aluminium-induced changes in the growth rate and mortality of brown trout, *Salmo trutta* L. J. Fish. Biol., 33: 171-179.
- Saleh, M. A. M. (1986). Toxicity of aluminium to *Oreochromis aureus* (Steindachner). M. Sc. Thesis, Institute of Aquaculture, University of Stirling, Stirling.
- Saunders, R. L. , Henderson, E. B. , Harmon, P. R., Johnstone, C. E. & Eales, J. G. (1983). Effects of low environmental pH on smolting of Atlantic salmon, *Salmo salar*. Can. J. Fish. Aquat. Sci., 40: 1203-1211.
- Sargent, J. R. Thomson, A. J., Daiglesh, H. H. & Dale A. D. (1975). Effects of temperature and salinity on the microsomal (Na⁺+ K⁺)-dependent adenosine tri-phosphate in the gills of the eel, *Anguilla anguilla*. Proc. 9th Europ. mar. biol. Symp. 463-474.

- Schreck, C. B. (1981). Stress and composition in teleostean fishes: responses to social and physical factors. In: Stress and Fish (A. D. Pickering ed.), pp. 295-321. Academic Press, N. Y., London.
- Schofield, C. L. (1976). Acid precipitation: effects on fish. Ambio, 5: 228-230.
- Schofield, C. L. & Tronjar, J. R. (1980). Aluminium toxicity to brook trout, *Salvelinus fontinalis*, in acidified waters. In: Polluted Rain (T. V. Tonbara, M. W. Miller & P. E. Morrow, eds.), pp. 341-362. Plenum Press, N.Y.
- Segner, H., Marthelar, R. & Lilinenbach, M. (1988). Growth, aluminium uptake and mucous cell morphometrics of early life stages of brown trout, *Salmo trutta*, in low pH water. Env. Biol. Fish., 21: 153-159.
- Serruya, C. & Pollinger, V. (1983). Lakes of the Warm Belt. Cambridge University Press. London, N.Y. pp 569.
- Shephard, K. & Simkiss, K. (1978). The effects of heavy metal ions on Ca²⁺ ATPase extracted from fish gills. Comp. Biochem. Physiol., 61b: 69-72.
- Siegel, N., Suhayda, C. & Haug, A. (1982). Aluminium changes in the conformation of calmodulin. Physiol. Chem., 14: 165-167.
- Siegel, N. & Haug, A. (1983a). Aluminium interactions calcium: Evidence for altered structure and function from optical and enzymatic studies. Biochem. Biophys. Acta., 744: 36-45.
- Siegel, N. & Haug, A. (1983b). Calmodulin-dependent functions of membrane potential in barley root plasma membrane vesicles: a biochemical model of aluminium toxicity in plants. Physiol. Plant., 59: 285-291.
- Silberged, E. K. (1974). Blood glucose; a sensitive indicator of environmental stress in fish. Bull. Environ. Contam. Toxicol., 11: 20-26.
- Silva, P., Solomon, R., Spokes, K., & Epstein, F. H. (1977). Ouabain inhibition of gill Na⁺/K⁺-ATPase: relationship to active chloride transport. J. Exp. Zool., 199: 419-426.
- Simkiss, K. (1974). Calcium metabolism of fish in relation to ageing. In: Ageing of Fish (T. B. Begenal, ed.), pp. 1-12. Old Woking: Unwin Brothers.
- Simmons, D. J. (1971). Calcium and skeletal tissue physiology in teleost fishes. Clin. Orthop. Rel. Reasech, 76; 244-280.
- Simpson, H. J. & Cook, H. L. (1983). Brackishwater aquaculture in pyrite bearing tropical soils. Aquaculture, 34: 333-350.
- Singh, V. P. (1985). Mangement and utilization of acid sulfate soils for aquaculture; A monograph submitted to the FAO/UNDP Regional Office for Asia and the Pacific, Bangkok, Thailand, pp. 105.
- Sioli, H. (1964). General features of the limnology of Amazonia. Verch. int. Ver. limnol., 15: 1053-1058.

- Sioli, H. (1968). Hydrochemistry and Geology in the Brazilian Amazon Region. Amazoniana, 1: 267-277.
- Skidmore, J. F. (1964). Toxicity of zinc compound to aquatic animals, with special reference to fish. Q. Rev. Biol., 39: 227-248.
- Skidmore, J. F. & Tovell, P. W. A. (1972). Toxic effects of zinc sulphate on the gills of rainbow trout. Water Res., 6: 217-230.
- Smart, G. (1976). The effects of ammonia on gill structure of the rainbow trout (*Salmo gairdneri*). J. Fish. Biol., 8: 41-475.
- Soivio, A. & Nikinmaa, M. (1981). The swelling of erythrocytes in relation to the oxygen affinity of the blood of the rainbow trout, *Salmo gairdneri* Richardson. In: Stress and Fish (A. D. Pickering, ed.), pp. 103-119. Academic Press, London.
- Soivio, A. & Oikari, A. (1976) Haematological effects of stress on a teleost, *Esox lucius* J. Fish Biol. 8: 397-411.
- Sorenson, J. R. J., Campbell, T. R. Tepper, L. B. & Lingg, R. D. (1974). Aluminium in the environment and human health. Environ. Health Perspect., 8: 3.
- Sprague, J. B. (1985). Factors that modify toxicity. In: Fundamentals of Aquatic Toxicology (G. M. Rand & Petrocelli, S. R. eds.), pp. 124-163. Hemisphere Publishing Corporation, Washington, N.Y., London.
- Spry, D. J. Wood, C. M. & Hodson, P. V. (1981). The effects of environmental acid on freshwater lakes in Ontario and the modifying effects of heavy metals: A literature review. Can. Tech. Rep. Fish. Aquat. Sci., 999: 145 pp.
- Stagg, R. M. and Shuttleworth, T. J. (1982a). The effect of copper on ionic regulation by the gills of the seawater adapted flounder, *Platichthys glesus* L. J. Comp. Physiol., 149: 83-90.
- Stagg, R. M. & Shuttleworth, T. J. (1982b). Na⁺-K⁺ ATPase, ouabain binding and ouabain sensitive oxygen consumption in gills from *Platichthys glesus* adapted to sea water and freshwater. J. Comp. Physiol., 147: 93-99.
- Staurnes, M., Sigholt, T. & Reite, O. B. (1984a). Reduced carbonic anhydrase and Na-K ATPase activity in gills of salmonids exposed to aluminium containing acid water. Experimentia., 40: 226-227.
- Staurnes, M., Vedagiri, P. and Reite, O. B. (1984b). Evidence that aluminium inhibits Na-K ATPase and carbonic anhydrase activity in the gills of the salmon, *Salmo salar* Acta. Physiol. Scand., 121: 8.
- Steele, C. W. (1985). Latent behavioural toxicity of copper to sea catfish, *Auratus felis*, and sheephead, *Archosargus probatocephalus*. J. Fish. Biol., 27: 643-654.
- Stuart, S. & Morris, R. (1985). The effects of season and exposure to reduced pH (abrupt and gradual) on some physiological parameters in brown trout (*Salmo trutta*).

Can. J. Zool., 63: 1078-1083.

Tam, S. C. and McWilliams, R. J. P. (1986). One problem of acid rain: aluminium. J. Inorg. Biochem., 26: 35-44.

Tandjung, S. D. (1982). The acute toxicity and histopathology of brook trout (*Salvelinus fontinalis*) exposed to aluminium in acid water. Ph.D. Thesis, Fordham University, New York. pp. 210.

Tietge, J. E., Jonson, R. D. & Bergman, H. L. (1988). Morphometric changes in gill secondary lamellae of brook trout (*Salvelinus fontinalis*) after long-term exposure to acid/ aluminium. Can. J. Fish. Aquat. Res., 45: 1643-1648.

Tipping, E., Backes, C. A. & Hurley, M. A. (1988). The complexation of protons, aluminium and calcium by aquatic humic substances. A model incorporating binding site heterogeneity and macroionic effects. Water Res., 22(5): 597-611.

Tort, L. & Torres, P. (1988). The effects of sublethal concentration of cadmium on haematological parameters in dogfish, *Scyliorhinus canicula*. J. Fish. Biol., 32: 277-282.

Towle, D.W., Gilma, M. E. & Hempel, J. D. (1977). Rapid modulation of gill Na⁺-K⁺-dependent ATPase activity during acclimation of killifish, *Fundulus heteroclitus*. to salinity change. J. Exp. Zool., 202: 179-186.

Trapp, G. A. (1986). Interactions of aluminium with cofactors, enzymes and other proteins. Kidney International, 29 (Suppl 18): 5-16.

Trigari, G., Borgatti, A. R., Pagaliaram, A & Nentrella (1985). Characterization of gill Na-K in the sea bass, *Dicentrarchus labrax*. L. Comp. Biochem. Physiol., 80B: 23-33.

Turnpenny, A. W. H. (1985). The fish population and water quality of some Welsh and Pennine Streams. CERL Report TPRD/L/2859/N85. Leatherhead Surrey, U.K.: Central electricity Research Laboratories (cited in Turnpenny, A. W. H., 1989. Field studies in fisheries in acid waters in the United Kingdom. In: Acid Toxicity and Aquatic Animals (edited by Morris *et al.*, 1989.)

Waldichuk, M. (1979). Review of problems. In: The Assessment of Sublethal Effects of Pollutants in the Sea. Phil. Trans. R. Soc. Lond. B 286: 399-424.

Walker, R. L., Wood, C. M. & Bergman, H. L. (1988). Effects of low calcium and aluminium on ventilation in the brook trout (*Salvelinus fontinalis*). Can. J. Fish. Aquat. Sci., 45: 1614-1622.

Watson, T. A. and Beamish, W. A. (1981). The effects of zinc on branchial adenosine triphosphatase enzymes *in vivo* from rainbow trout, *Salmo gardeneri*. Comp. Biochem. Physiol., 68C: 167-173.

Watson, T. A. and Beamish, F. W. H. (1980). Effect of zinc on branchial ATPase activity *in vivo* in rainbow trout *Salmo gardeneri*. Comp. Biochem. Physiol., 66C: 77-82.

Wedemeyer, G. A. & McLeay, D. J. (1981). Methods for determining the tolerance of fishes to environmental stresses. In: Stress and Fish (A. D. Pickering, ed.), pp 247-275, Academic Press, London & N.Y.

Weiss, R. E. & Watabe (1978). Studies on the biology of fish bone. 1. Bone reabsorption after scale removal. Comp. Biochem. Physiol., 60A; 207-211.

Wendelaar Bonga, S. E. & Flik, G. (1982). Prolactin and calcium metabolism in a teleost fish. In: Comparative Endocrinology of Calcium Regulation (C. Poguro and P. K. Pang eds). Scientific Societies Press, Tokyo, pp. 21-26.

Wendelaar Bonga, S. E. & Lammers, P. I. (1982). Effects of calcitonin on ultrastructure and mineral content of bone and scales of the cichlid teleost, *Sarotherodon mossambicus*. Gen. Comp. Endocrinol., 48: 60-70.

Wendelaar Bonga, S. E., Meij, J. C. A., Van der Krabben, W. A. W. A. & Flik, G. (1984a). Prolactin and acid stress in the teleost, *Sarotherodon mossambicus*. Gen. Comp. Endocrinol., 55: 323-332.

Wendelaar Bonga, S. E., Meij, J. C. A., Van der Krabben, W. A. W. A. & Flik, G. (1984b). The effect of water acidification on prolactin cells and pars intermedia PAS positive cells in the teleost fish, *Oreochromis mossambicus*, and *Carassius auratus*. Cell Tiss. Res., 238: 601-609.

Wendelaar Bonga, S. E., Flik, G. & Fenwick, J. C. (1984c). Prolactin and calcium metabolism in fish: effects on plasma calcium and high-affinity Ca^{2+} -ATPase in gills. In: Endocrine Control of bone and Calcium Metabolism (D. V. Cohn, Z. T. Potts, Jr & T. Fujita, eds.), pp. 188-190. Elsevier Science Publishers B. V.

Wendelaar Bonga, S. E. & Dederen, T. H. T. (1986). Effects of acidified water on fish. Endeavour, New Series, 10(4): 198-203.

Wendelaar-Bonga, S. E., Flik, G. & Balm, P. H. M. (1987). Physiological adaptation to acid stress in fish. Annals. Soc. r. Zool. Belg., 117 (Supplement 1): 243-254.

Wendelaar Bonga, S. E. & Balm, P. H. M. (1989). Endocrine responses to acid stress in fish. In: Acid Toxicity and Aquatic Animals (R. Morris, E. W. Tylor, G. D. Howells, D. J. A. Brown & J. A. Brown eds.), pp. 243-261. Cambridge University Press, Cambridge, N. Y. & Sydney.

Westin, D. T. (1974). Nitrate and nitrite toxicity to salmonid fishes. Prog. Fish. Cult., 36: 86-89.

Witters, H. E. (1986). Acute acid exposure of rainbow trout, *Salmo gairdneri* Richardson.; effects of aluminium and calcium on ion balance and haematology. Aquat. Toxicol., 8: 197-210.

Witters, H. E., Puymbrock, S. V. & Vanderborcht, O. K. J. (1991). Adrenergic responses to physiological disturbances in rainbow trout, *Oncorhynchus mykiss*, exposed to aluminium at acid pH. Can. J. Fish. Aquat. Sci., 48; 414-420.

Witters, H., Vangenechten, J., Van Puymbroeck, S. & Vanderborght, O. (1987). Ionoregulatory and haematological responses of rainbow trout, *Salmo gairdneri*, to chronic acid and aluminium stress. Annals. Soc. r. Zool. Belg., 117 (Supplement 1): 411-420.

Witters, H. E., Van Puymbroeck, Vangenechten and Vanderborght (1990). the effect of humic substances on the toxicity of aluminium to adult rainbow trout, *Oncorhynchus mykiss* (Walbaum). J. Fish. Biol., 37,43-53.

Wood, C. M. & Regano, M. S. (1986). Physiological responses to acid stress in crayfish (*Orconectes propinquus*): Haemolymph ions, acid-base status and exchanges with the environment. Can. J. Fish. Aquat. Sci., 43: 1017-1026.

Wood, C. M. & McDonald, D. G. (1987). The physiology of acid/aluminium stress in rainbow trout. Annals. Soc. r. Zool. Belg., 117 (Supplement 1): 399-410.

Wood, C. M., McDonald, D. G., Booth, C. E., Simmons, B. P., Ingersoll, C. G. & Bergman, H. L. (1988a). Physiological evidence of acclimation to acid/aluminium stress in adult brook trout (*Salvelinus fontinalis*). 1. Blood composition and net sodium fluxes. Can. J. Fish. Aquat. Sci., 45: 1587-1596.

Wood, C. M., Simmon, B. P., Mount, D. R. & Bergman, H. L. (1988b). Physiological evidence of acclimation to acid/aluminium stress in adult brook trout (*Salvelinus fontinalis*). 2. Blood parameters by cannulation. Can. J. Fish. Aquat. Sci., 45: 1597-1605.

Wood, C. M., Playle, R. C., Simmons, B. P. & McDonald, M. G. (1988c). Blood gases, acid-base status, ions and haematology in adult brook trout (*Salvelinus fontinalis*) under acid/aluminium exposure. Can. J. Fish. Aquat. Sci., 45: 1575-1586.

Wood, C. M. (1989) The physiological problems of fish in acid waters. In: Acid toxicity and Aquatic Animals pp. 125-155 (R. Morris, E. W. Taylor, G. D. Howells, D. J. A. Brown & J. A. Brown, eds.). Society for Experimental Biology Seminar Series, 34, Cambridge University Press, Cambridge, N. Y. Sydney.

Wood, C. M., McDonald, D. G., Ingersoll, C. G., Mount, D. R., Johansson, O. E., Landsberger, S. & Bergman, H. L. (1990). Effects of water acidity, calcium and aluminium on whole body ions of brook trout (*Salvelinus fontinalis*) continuously exposed from fertilization to swim up; A study by instrumental neutron activation analysis. Can. J. Fish. Aquat. Sci., 47: 1593-1603.

Wright, P. A. & Wood, C. M. (1985). An analysis of branchial ammonia excretion in the freshwater rainbow trout: effects of environmental pH change and sodium uptake blockade. J. Exp. Biol., 114: 329-353.

Wright, R. F. & Gjessing, E. T. (1976). Changes in the chemical composition in the lakes. Ambio, 5: 219-223.

Yamada, J. (1956). On the mechanism of the appearance of the scale structure. VI. Some observations associated with the absorption of scales in the goldfish. Bull. Fac. Fish. Hokkaido Univ., 7: 202-207.

Youson, J. H. & Neville, C. M. (1987). Deposition of aluminium in the gill epithelium of rainbow trout (*Salmo gairdneri* Richardson) subjected to sublethal concentrations of the metal. Can. J. Zool., 65: 647-656.

You-Han, Xu. (1986). The inhibition of calmodulin dependent Ca^{2+} and Mg^{2+} ATPase in erythrocyte membrane by aluminium ions. Acta. Biochem. Biophysic. Sca., 18(4): 367-371.

APPENDICES

APPENDIX-1

Water quality parameters in fish holding system

Parameters	Mean (\pm S.D.)	Range
Sodium (mg l^{-1})	4.37 \pm 1.17	2.60- 6.20
Potassium (mg l^{-1})	1.74 \pm 0.78	0.70- 2.80
Calcium (mg l^{-1})	19.15 \pm 6.60	10.70-30.50
Magnesium (mg l^{-1})	1.93 \pm 0.52	1.40- 2.50
$\text{NH}_3\text{-N}$ (mg l^{-1})	0.11 \pm 0.06	0.03- 0.184
Nitrite-N (mg l^{-1})	0.009 \pm 0.004	0.006-0.014
Nitrate-N (mg l^{-1})	8.31 \pm 4.90	3.20-16.30

APPENDIX-2

Chemicals used to provide the ionic composition in the experimental media (see Table-2.1.; Chapter 2).

Stock Solutions	Reagents (Analar grade)
1	CaCl ₂ , 6H ₂ O NaCl NaO ₃ KCl
2	MgSO ₄ , 7H ₂ O NaSO ₄
3	NaHCO ₃

Adapted from HMSO (1969)

APPENDIX-3

Processing routine for the automatic tissue processor

30% methylated spirits	1 h
80% methylated spirits	2 h
100% methylated spirits	2 h
100% methylated spirits	2 h
Absolute alcohol	2 h
Chloroform	2 h
Chloroform	1 h
Chloroform	1 h
Paraffin wax	2 h
Paraffin wax	2 h

APPENDIX-4

Haematoxyline-Eosin staining

(1) Bring section to water by bath in:

Xylene	5 min
Absolute alcohol	2 min
Methylated spirit	1.5 min
(2) Haematoxyline	10 min
(3) Wash in tap water	1 min
(4) Differentiate in 1% acid alcohol	4 quick drops
(5) Wash in tap water	1 min
(6) Scott's tap water substitute	1 min
(7) Eosin	3 min
(8) Methylated spirit	30 s
(9) Absolute alcohol	2 min
(10) Absolute alcohol	1.5 min
(11) Xylene	5 min
(12) Mount in synthetic resin	

APPENDIX-5

Alcian blue staining at pH 2.5

Alcian blue stain:

Alcian blue 0.5g

Glacial acetic acid 3 ml

Distilled water to 100 ml

- | | |
|---------------------------------------|---------|
| (1) Bring section to water | |
| (2) Alcian blue stain | 20 min |
| (3) Rinse in distilled water | |
| (4) Wash in running water | 5 min |
| (5) Counter stain with 1% neutral red | |
| (6) Methylated spirit | 30 s |
| (7) Absolute alcohol | 2 min |
| (8) Absolute alcohol | 1.5 min |
| (9) Xylene | 5 min |
| (10) Mount in synthetic resin | |

Observations: Acid mucopolysaccharide :green

Cell nuclei :red

Background :yellow

APPENDIX-6

Periodic Acid - Schiff's (PAS) Reaction

- | | |
|---|---------|
| (1) Sections to water | |
| (2) 1% Periodic acid | 10 min |
| (3) Wash in tap water | 5 min |
| (4) Schiff's reagent | 20 min |
| (5) Wash in tap water | |
| (6) Haematoxyline | 5 min |
| (7) Wash in tap water | |
| (8) Differentiate in 1% acid alcohol | |
| (9) Blue in Scott's tap water substitue | |
| (10) Wash in tap water | |
| (11) Methylated spirit | 30 s |
| (12) Absolute alcohol | 1 min |
| (13) 0.3% tartrazine in cellosive | 3 min |
| (14) Absolut alcohol | 1.5 min |
| (15) Xylene | 5 min |
| (16) Mount in synthetic resin | |

Results : PAS positve red or megenta

Nuclei ; blue

APPENDIX-7

Formulation of fish feed (used in Radioisotopic Experiment)

	%
Casein	45
Gelatin	5
Corn Starch	15
α-Cellulase	10
Dextrin	5
Fish Oil	12
Vitamin Premix	2
Minerals*	6

* calcium-salt was excluded